

Original instructions
Service manual

SHANTUI

Applicable models SFE15T/18T/20T

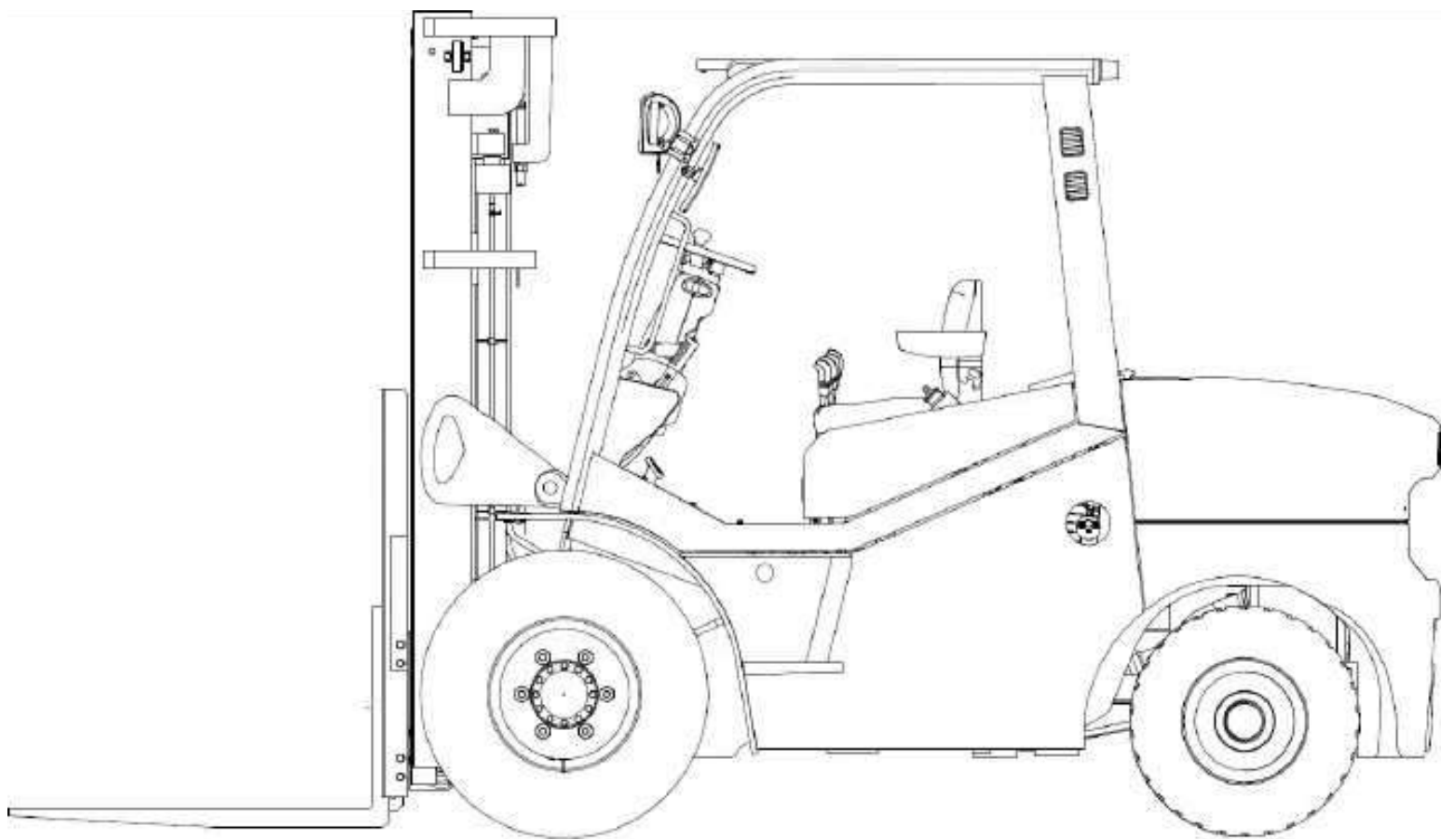

Thank you for choosing a SHANTUI forklift truck .We have developed this manual specifically to allow you to take complete advantage of the technical features and styling of your new forklift. The instructions for correct use and maintenance, as well as recommendations and cautions for practical and safe forklift use, are provided in the following pages. Carefully read this manual, along with the attached “Rules for approved use of industrial vehicles”. Cordially, SHANTUI R&D

SHANTUI Forklift provides whole product range including diesel /gasoline/ LPG trucks with load capacities of 1 to 10 tonnes and electric / warehouse trucks. The company has automated painting line, vehicle assembly line and key components production line, which provides strong base to ensure business growth.

Contents

Company Presentation.....	2
Welcome	2
Introduction.....	7
Summary Data for Technical Assistance	8
General Information	8
General Premise	8
Service.....	9
Spare Parts.....	9
Warranty Booklet	9
How to Consult the Manual	9
Normative References	9
Areas with risk of explosion and handling of explosive loads	10
Type of use and contraindications for use.....	10
Use Limitations	11
Driving on public roads.....	11
General Forklift Description.....	11
Equipment Assembly	12
Modifications to Forklift	12
Forklift Delivery.....	12
Safety	13
Safety regulations	14
General Precautions.....	14
General Safety Rules	14
Safety regulations in case of accidental lateral tipping.....	15
Flooring requirements	15
Safety Regulations Relative to Forklift Use.....	15
Safety Regulations Relative to Operating Materials	16
Safety regulations during tyre inflation.....	17
Placement of data plates and labels	18
Description of data plates and labels	19
Safety features	21
Noise	23
Electromagnetic Compliance.....	23
Vibrations.....	23

Knowledge of the Forklift.....	24
General forklift view	25
General front view	25
General rear view	26
Internal view	27
Instrumentation and Controls	28
General view of dashboard	28
Start/stop key	29
Combination switch for lights	29
EMERGENCY STOP pushbutton.....	29
Distributor control levers	30
Horn.....	32
Parking brake	32
Service brake.....	32
Reversing lever on the steering wheel and accelerator pedal.....	33
Adjustment of the steering wheel	33
Adjustment of the seat BF1	33
Seat belt BF1.....	34
Multifunction panel.....	35
Forklift identification	39
Location of data plates	39
Chassis punching.....	40
Forklift identification plate.....	40
Capacity plate.....	41
Lubricants plate.....	41
Use and Operation.....	42
Forklift Transport and Lifting	43
Transporting the Forklift	43
Environmental Conditions for Transport and Storage	43
Loading and unloading the truck	44
Commissioning	45
Breaking-In.....	45
Daily checks before use.....	46

Use of truck	48
Stepping on/off the truck	48
Starting the forklift	49
Sit correctly on the seat	49
Forklift operation.....	50
Changing direction of travel	51
Forklift Braking/Stopping	52
Leaving truck.....	53
Steering the forklift.....	54
Speed Restrictions	55
Stopping the forklift in an EMERGENCY	56
Forklift Use in Cold-Storage Rooms.	56
Load Placement.....	57
Adjustment of the fork distance.....	57
Taking up loads	58
Deposit the load.....	58
Towing trailers	58
Forklift towing	59
Battery recharging	60
Maintenance	62
General Information	63
Operations Preliminary to Maintenance	63
Maintenance as required.....	64
Cleaning the Forklift.....	64
Seat and seat belt cleaning.....	64
Lamp replacement (if applicable)	64
Rear lights unit lamps.....	65
Work light replacement procedure (optional).....	66
Tyrewear check	66
Wheel change	68
Changing the battery.....	70
Changing a fuse.....	72
Scheduled Maintenance.....	74

General.....	74
Synoptic Table of Maintenance Operations.....	74
EVERY 1000 HOURS.....	75
Check wheel nut tightness (every 10 hours during run-in)	75
Chain tension check and adjustment.....	76
Check hydraulic tank oil level.....	76
Cleaning of the electronic panel	77
Fork carriage guide greasing	78
Trunnions greasing.....	78
Lubricate lift chain	79
Rolling tracks greasing.....	79
Change the hydraulic oil filter cartridge	80
Chain check and maintenance	81
Seat belt conditions and performance check.....	82
Additional check for Duo-sensitive belts.....	82
Fork arm check	84
Putting out of Commission.....	85
General Information.....	85
Temporary Putting Out of Commission.....	85
Checks and Inspections after a Long Period of Inactivity	85
Permanent Putting Out of Commission (Demolition).....	85
Disposal of harmful substances	86
Supply Table	86
Technical data.....	87
Overall dimensions for three-wheel truck	88
SFE15T/18T/20T Datasheet Conforms to VDI 2198.....	89
Alternative lift characteristics.....	90
Three-wheel truck tyre characteristics.....	92
Battery dimensions and weights.....	92
Lamps	92
DIAGRAMS	93

Introduction

Summary Data for Technical Assistance

Model	
Serial number	
Type of lift	
Tyre	
Delivery date	
CE Declaration of Compliance n°	

- We advise you to record the forklift data in the above table to facilitate any notifications to the sales network.
- Contact the authorized sales network for all problems related to the forklift and for any spare parts requirements.
- When repairs are necessary, use original spare parts only: only in this way will the forklift's technical characteristics remain unvaried over time.
- Follow the instructions provided in the spare parts catalogue (which can be requested from the authorized sales network) to order spare parts.

General Information

General Premise



Read the warnings given below carefully before using the forklift.

- Many accidents are caused by insufficient knowledge and by not following the safety rules to be put into practice during forklift use and during maintenance operations on the forklift.
- The forklift must only be used by adequately trained personnel; contact the sales network for the necessary training.
- To use the truck and prevent accidents, the operator is required to read, understand and comply with all the instructions contained in this manual and in the attached "Rules for the use of industrial vehicles", as well as those on the labels fitted on the truck.
- It is absolutely forbidden for anyone to use the forklift for uses other than those expressly foreseen and documented.
- The manufacturer takes no responsibility for any accidents or damage to persons or property arising from failure to observe both the "Rules for the use of industrial vehicles" and the rules given in this manual.
- This manual and the attached "Rules for the use of industrial vehicles" must be kept carefully and must always be on the truck for fast consultancy.
- For informative clarity, some illustrations in this manual show the forklift without the safety guards (guards, panels, etc.). Do not use the forklift without safety guards. Interventions and maintenance operations must be performed **EXCLUSIVELY** by qualified technical personnel.

Service

- For important repairs and maintenance operations, contact the sales network, which has qualified personnel available

with the relative equipment and original spare parts.

Spare Parts

- Use only original spare parts supplied by the manufacturer. The use of non-original spare parts voids the warranty conditions and makes the user

responsible for any accidents due to the inadequacy of the non-original components.

Warranty Booklet

- Each forklift comes with a Warranty Booklet in which the summary of the regulations that regulate the performance

of the service under warranty, the intervention record and the declaration of delivery/receipt are written.

How to Consult the Manual

- There is a table of contents at the beginning of this manual to facilitate consultation. This manual is subdivided into chapters with different subjects. Each page heading indicates the chapter number, while the footer indicates the manual type, the code, the language and the edition of the manual.
- The following symbols are used to identify the safety messages used in this manual:

DANGER

DANGER FOR PEOPLE the partial or total noncompliance with the rules highlighted with this symbol can cause serious risks for operator and maintenance personnel safety.



CAUTION

DANGER FOR THE FORKLIFT the partial or total noncompliance with the rules highlighted with this symbol can cause serious damage to the forklift and, in some cases, can void the warranty.



ENVIRONMENT NOTE

The indications given here take account of the standard, ISO 14001 (Environment management systems - Requirements and guide) and these must be complied with as environmental damage may be caused otherwise.



NOTE

IMPORTANT INFORMATION This symbol indicates important messages for the operator.

Normative References

This truck complies with Machinery Directive 2000/14/EC, adapted to handling trucks with the harmonized standards EN 1726-1 (for trucks with capacity less than or equal to 10,000 kg and tractors with towing capacity less than or equal to 20,000 N). It is also in compliance with the

Electromagnetic Compatibility Directive 2004/108/EC, relative to handling trucks in accordance with the harmonized standard EN 12895.

The noise tests were carried out in accordance with harmonized standard EN 12053 in line with European Directive 2000/14/EC. The vibration tests were carried out in accordance with standard EN 13059 and declared in accordance with

standard EN 12096 in line with European Directive 2002/44/EC. The truck and its components have been designed and manufactured according to the dictates of ISO 14001 on "Environmental management systems".

Areas with risk of explosion and handling of explosive loads



DANGER

It is absolutely forbidden to use the forklift in environments with risk of explosion where gases, vapors and inflammable and explosive powders are present or to handle explosive loads. For forklifts that have to operate in areas at risk of

explosion or handle explosive loads, a suitable setup is required, which must be supplied with a specific EC declaration of compliance, which replaces that of the standard machine, and with the relative use and maintenance manual.

Type of use and contraindications for use

The truck is intended exclusively for moving reasonably stable loads: it can lift and/or transport, by means of the fork arms, all types of loads whose weight and centre-of-gravity fall within the fixed values shown on the lifting capacity plate. It must only be used for these operations.

The following are considered normal use conditions:

- use (travelling and/or lifting) on basically compact, smooth, at and suitably prepared surfaces;
- use with the centre-of-gravity of the load approximately on the forklift's longitudinal median plane;
- load must be evenly distributed on the fork arms.
- travelling with the lift tilted backwards, when possible, and the load in a lowered position.



NOTE

Any other use renders the user solely responsible for injury/damage to persons and/or objects and voids any warranty condition. As an example, situations to be avoided are listed below; these situations represent incorrect use which, above all, can involve the danger of accidental overturning:

- approaching curves at too high a speed;
- making sharp turns while travelling at high speed;
- moving with the load raised;
- turning and/or moving across slopes;
- transporting oscillating loads or loads whose centre-of-gravity is considerably displaced with respect to the truck's longitudinal median plane;
- moving upwards or downwards on a slope with the load facing downwards;
- travelling over irregular floors (uneven or sloping surfaces or yielding ground);

- overloading the forklift;
- colliding with stationary and/or movable structures;
- incorrectly assessing the centre of gravity of the forklift.
- tilting the lifting unit forward with the fork arms raised (with or without load) when not near the shelf.

Use Limitations

Do not use the forklift in dusty environments or in atmospheres full of dust in suspension, which put the environment at risk of explosion. When the forklift is used in environments with a strong presence of brackish air or water, the electric or electronic components might cease to work over - time due to corrosion. Special precautions might be required to operate under severe conditions (extreme climates, cold-storage rooms, in the presence of strong magnetic fields, etc.): contact the sales network.

To ensure safe operation, the use of the "load rack" or "additional net" for the overhead guard, as protection against small falling objects, may be required.

Do not use outside the climatic conditions indicated below:

- Maximum ambient temperature: +35°C
- Minimum ambient temperature for trucks used under normal outdoor conditions: -15°C
- Altitude up to 1 000 m
- Relative humidity between 30% and 95% (without condensation).

Driving on public roads

It is forbidden to drive the fork lift truck on public roads, unless the truck has been specially approved for driving on roads with no load on the

forks or for brief and occasional crossing with a load on the forks as well.

General Forklift Description

The model described in this manual is an electric forklift with seated operator and counterbalanced forks.

This model can be equipped with the following main equipment:

- side shifts
- positioners
- grippers with jaws or forks
- tipping
- load arms
-



NOTE

For use of a piece of field equipment after the sale, it is necessary to apply to the authorized dealer which will verify its feasibility and, if applicable, perform the equipment installation, the updating of the residual capacity plates and the testing. The equipment will also have to be provided with identification plate and Assembly and Instructions Manual.



NOTE

The "crane arm" attachment changes the original intended use of the forklift, which may not move freely oscillating suspended loads. For such application a specific approval and EC certification of conformity is required for the forklift equipped in this manner. In this regard, it is necessary to contact the authorized dealer.

Equipment Assembly

Assemble the equipment following the assembly and use instructions supplied with it.

Modifications to Forklift

Contact the sales network if the forklift will be used for non-conventional jobs and must undergo some modifications in order to perform such jobs.



NOTE

DO NOT make modifications to the forklift without previous authorization from the

manufacturer, to be obtained by contacting the authorized sales network.

Forklift Delivery

- The forklift is tested and inspected by the manufacturer before it leaves the plant. It is then inspected and set up by the authorized dealer.
- Upon delivery, make sure that the forklift includes all requested accessories and that the following documentation has been supplied with it:
 - A. n°1 Use and Maintenance Manual;
 - B. n°1 Manual or "Rules for approved use of industrial vehicles. "
 - C. n°1 EC Declaration of Compliance
 - D. n°1 Warranty Booklet.



NOTE

It is a good idea to carefully preserve documents A-B-C-D so that they can follow the forklift during its life span.

- Once these conditions have been verified, confirm regular delivery to the dealer.

Safety

Safety regulations

General Precautions



NOTE

Some safety regulations to be followed when using the forklift are listed below. These regulations integrate those in the manual "Rules for approved use of industrial vehicles".

General Safety Rules

- Only allow qualified, trained and authorized personnel to use the forklift.
- Do not install equipment on the forklift unless supplied or indicated by the manufacturer.
- Maintain the forklift in full working efficiency in order to keep any type of risk to the minimum.
- Do not use the truck with hoods or doors open or with guards removed.
- The data plates found on the forklift must be kept in good condition and replaced if damaged.
- Carefully read and follow all of the safety indications found on the forklift.
- Make sure that the forklift has sufficient overhead clearance.
- Do not park the forklift in front of fire-fighting devices or re escapes or anywhere that it blocks traffic.
- If the forklift shows signs of failure or breakage and there is reason to consider it unsafe, stop, park it, and notify the maintenance manager.
- Pay attention to the distances from high voltage overhead cables. Comply with the safety distances established by the competent authorities.
- Never raise the load using just one fork.
- Place the load on the fork carriage or in such a way that the center of gravity of the load is as close as possible to the fork carriage.
- The load must be placed on the fork arms so that the centre of gravity falls lengthwise on the midpoint between the fork arms.
- Do not drive with loads decentralized laterally with respect to the forklift's median axis. Lack of compliance with this regulation can compromise forklift stability.
- Make sure that the surface on which the load rests is able to support its weight.
- Always use safety clothing compliant with current regulations and any personal protective equipment that may be applicable.
- Do not travel on loose or hilly ground or on steps.
- Do not travel with loads raised more than 300 mm from ground level.
- Do not turn or stack on slopes.
- Do not overload the forklift beyond the capacity limits indicated on the capacity plates.
- Always use the operator restraint systems (e.g. seat belts).

Safety regulations in case of accidental lateral tipping

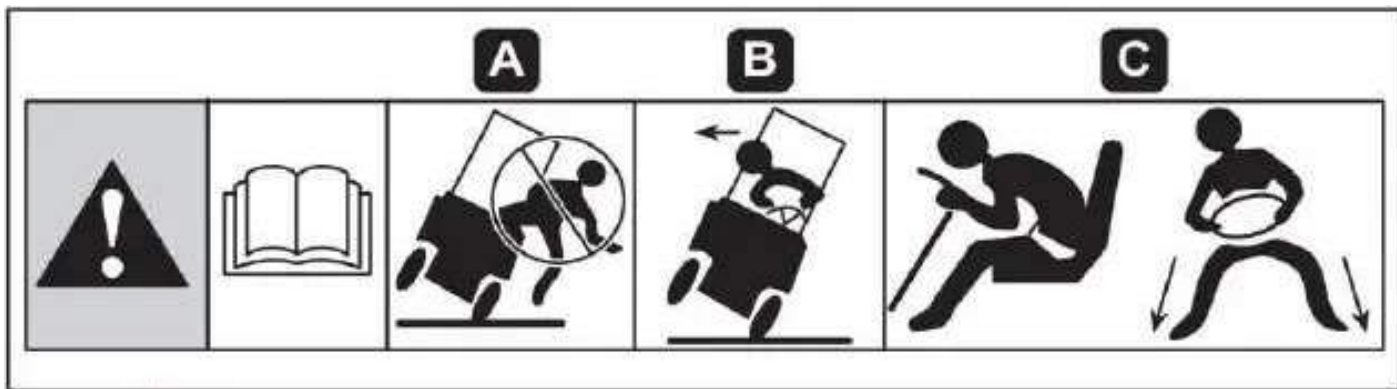

If as a result of incorrect manoeuvring the truck appears to be tipping over sideways, carefully follow the instructions below:

- Do not leave the forklift truck.
- Tilt your head forward and move your body in the opposite direction to which the forklift is tipping.
- Remain firmly seated, grip the steering wheel and dig your heels in. Wait until the truck has reached a stable position before leaving the truck.

Flooring requirements

Use the forklift on floors that are at, prepared, substantially compact, smooth, free of obstacles and not yielding.

Safety Regulations Relative to Forklift Use

- The operator must familiarize himself with the forklift to be able to better describe any defects and assist maintenance personnel.
- The operator, trained and authorized to use the forklift, must be familiar with the controls and performances of the forklift.
- Any defect (squeaking, leaks, etc.) must be promptly reported because, if neglected, it could cause more serious failures/defects.
- Carry out the inspections indicated in the chapter on "Daily Inspections".



ENVIRONMENT NOTE

Report any oil and/or battery fluid leaks: they are dangerous and highly polluting.



CAUTION

If you notice a burning smell, stop the forklift and turn off the engine, then disconnect the battery.

Safety Regulations Relative to Operating Materials

Rules for handling and disposing of operating materials



ENVIRONMENT NOTE

Improper use and disposal of operating and cleaning materials can cause serious damage to the environment.

Always use and handle the operating materials in a suitable manner and follow the manufacturer's instructions for the product's use.

Keep the operating materials only in containers intended for this purpose and in a location that satisfies the requirements.

The operating materials may be flammable, so avoid contact with hot objects or open flames.

When topping up the operating materials, only

clean containers should be used. Follow the manufacturer's safety and disposal instructions regarding the operating and cleaning materials.

Do not disperse oils or other operating liquids! Any spilt liquid must be immediately collected and neutralised with a binding material (such as an oil binder) and then disposed of in accordance with current regulations.

Always abide by the regulations of the antipollution laws!

Before carrying out work that involves lubrication, filter replacement or hydraulic equipment interventions, the area in question must be thoroughly cleaned.

The replaced parts must always be disposed of in accordance with the anti-pollution laws.



ENVIRONMENT NOTE

The incorrect or unlawful use of brake fluid is harmful to people's health and the environment.

Oils

Do not allow to come into contact with the skin.

Do not inhale oil vapors.

Wear appropriate means of individual protection during forklift maintenance operations (gloves, goggles, etc.) to prevent the oil from coming into contact with your skin.



ENVIRONMENT NOTE

The used oils (brake, motor, transmission, gearbox and hydraulic oil) and relative filters contain substances hazardous to the environment and must be disposed of according to current regulations. We advise you to contact the authorised service network.



DANGER

The penetration in the skin of hydraulic oil that has leaked under pressure from the forklift's hydraulic system is dangerous. If this type of lesion should occur, contact a doctor immediately.



DANGER

Small high pressure jets of oil can penetrate the skin. Look for any leaks using a piece of card board.

Battery Acid

Do not inhale the vapor: it is poisonous.

Use adequate means of individual protection to prevent contact with the skin.

Battery acid is corrosive: if it should come into contact with your skin, rinse abundantly with water.

Explosive gas mixtures can form when charging the battery; therefore, the rooms in which the battery is charged must be in compliance with the specific regulations on the subject (e.g. CEI-EN 50272-3 ...).

DO NOT smoke or use open flames and lights within a 2 m radius from the charged battery and in the battery charging area.



NOTE

For greater information, consult the specific battery manual that comes with the battery.



ENVIRONMENT NOTE

The batteries contain substances that are hazardous to the environment. The replacement and disposal of the life-expired battery must be carried out as required by law. We advise you to contact the authorised service network that is equipped for eco-friendly disposal in accordance with current regulations.

Safety regulations during tyre inflation

- The tyres must be checked according to the table of scheduled operations fixed by the manufacturer.
- Check their integrity and pressure.



DANGER

During inflation, stay to the side of the tyre and never in front of it: "Danger of explosion."
Never exceed the predetermined pressures.

Placement of data plates and labels

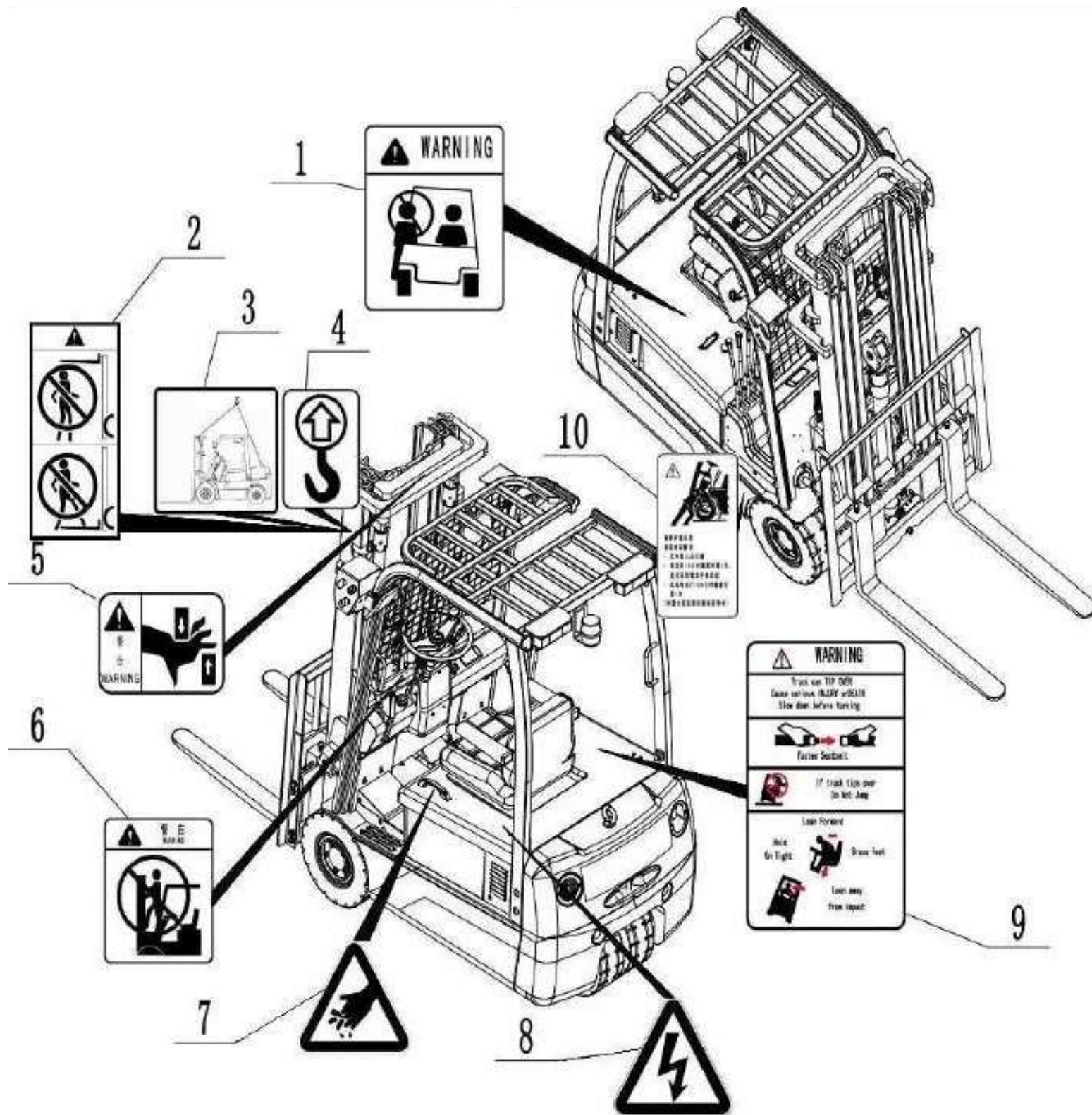

1.Forbid carrying person	2 .Forbidden stand on or beneath the fork.
3.Lift sign	4.Indication of lifting point
5.Warning sign: injury to hand	6.Forbid entering space behind the mast
7.hood roll hand warning	8.electric shock warning
9.safety belt warning	10.fasten wheel

Description of data plates and labels

This symbol prohibits carrying person



This symbol prohibits standing or walking under the raised fork arms and lifting or transporting people with the truck.



This symbol indicates Lift sign

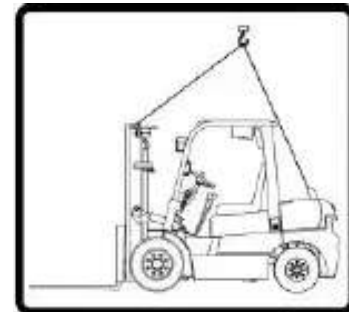

This symbol indicates where to insert the slings for lifting the truck.



This symbol indicates Warning sign: injury to hand



This symbol indicates Forbid entering space behind the mast



This symbol indicates hood roll hand warning



This symbol indicates electric shock warning



This label indicates the behaviour to be adopted in case of accidental tipping over sideways, described in the section "Safety regulations in case of accidental tipping over sideways"; check that you have fully understood the contents of this section before operating the fork lift truck.

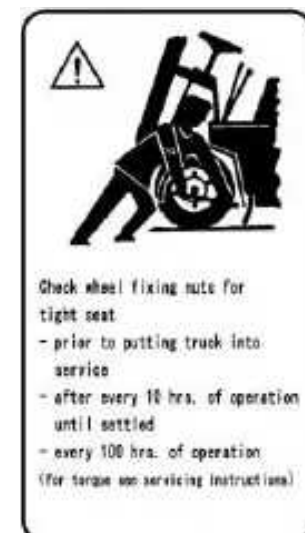

This plate is removed by the technician once installation has been completed, and it indicates the following: Inspect the tightness of the wheel fixing screws with the following frequency: prior to commissioning; every 10 working hours until the truck has settled; after settling, every 100 working hours (refer to the servicing instructions for information on the tightening torque).



Safety features

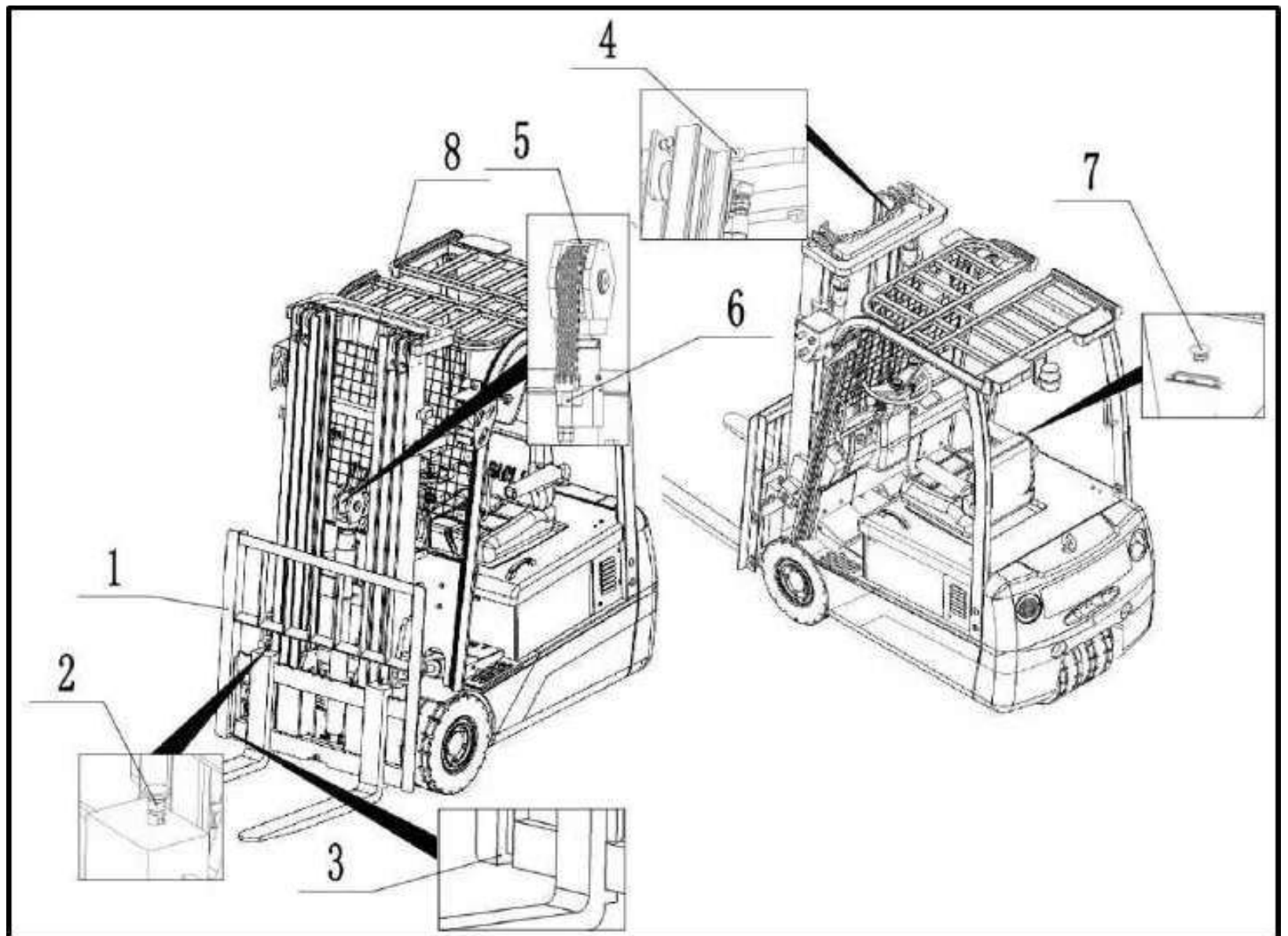

Sollevatore:

1. Load carrying grate	5. Chain retaining device
2. Fork stop latches	6. Chain tension rod retaining device
3. Fork retaining device	7. Emergency stop button
4. Fork carriage retaining device	8. Shear protection net

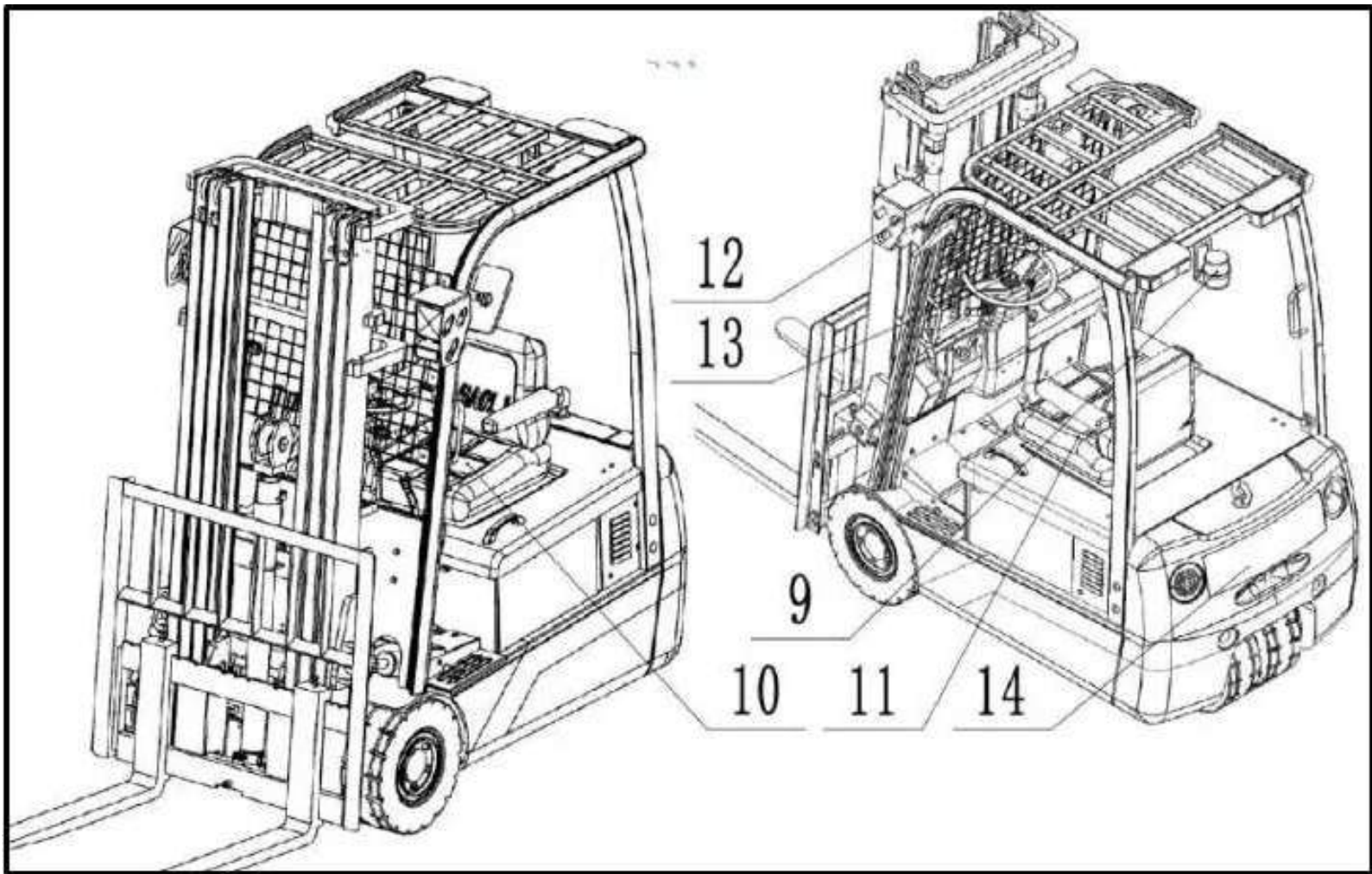

carro:

9. flashing beacon	12. Overhead guard
10. "Seat switch" microswitch that blocks operation of the truck when the operator is not seated on the driver's seat	13. Alarm horn
11. Restraining belt	14. Reverse gear warning buzzer

The operator must be aware of the presence of the safety devices cited above.

i NOTE

These devices must be checked daily, as described in Chapter 4.

Noise

Sound pressure level in driver's seat	$L_{paz} < 75\text{db (A)}$
Uncertainty factor	$k_{pa} = 4\text{db (A)}$

The value is determined in a test cycle in accordance with Harmonised European Standards EN 12053 and EN 4871 with weighted time percentages for the Translation, Lifting and Idling modes. It can only be used as a comparison value for different forklift trucks.



NOTE

Noise values that are lower or higher than those indicated above can occur during actual forklift use, for example, following different operating modes, different environmental conditions, additional noise sources

Electromagnetic Compliance

This truck also complies with the Electromagnetic Compatibility Directive 89/336/EEC and 2004/108/EEC, relative to industrial trucks in accordance with the harmonized standard EN1726-1.

Vibrations

Value of the vibrations to which the body is exposed

3-wheel truck with BF1 seat		
Flow rate	Value $a_{w,z}$	Uncertainty
900kg	0.87 m/s^2	$k=0.3 \text{ m/s}^2$

Value of the vibrations to which the hands-arms are exposed:

- $a_w < 1.3 \text{ m/s}^2$.

The value "for the body" has been calculated and declared in conformity with the Harmonized European Standards EN13059 and EN12096 and is based on the Translation mode, the only mode that exposes the driver to significant vibrations. The aforesaid standard is not applicable to the vibration measurement "for hands-arms"; in fact it has been shown that the relative value is generally less than 1.3 m/s^2 .



NOTE

The value expressed above can be used to compare forklift trucks of the same category. It cannot be assumed for the determination of the daily vibration exposure of the operator during actual operation of the truck; these vibrations depend on the conditions of use (floor condition, method of use, etc.) and thus the daily exposure must be calculated using the relative workplace data.

Knowledge of the Forklift

General forklift view

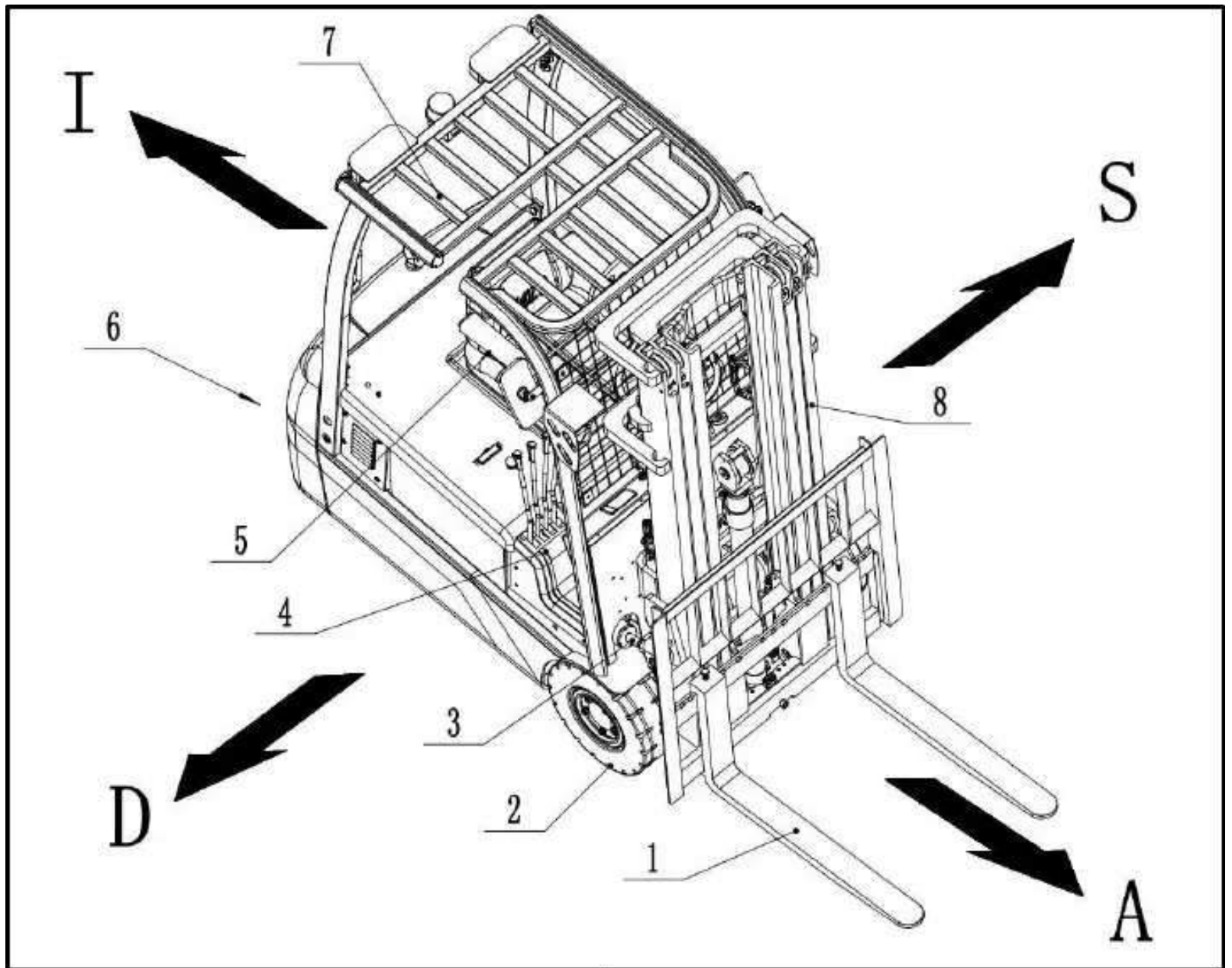

General front view

1. Fork arms	7. Overhead guard
2. Front wheels	8. Lift
3. Tilt cylinders	A. Forward
4. Lift control lever panel	D. Right
5. Sit	I. Backwards
6. Rear wheels	S. Left

General rear view

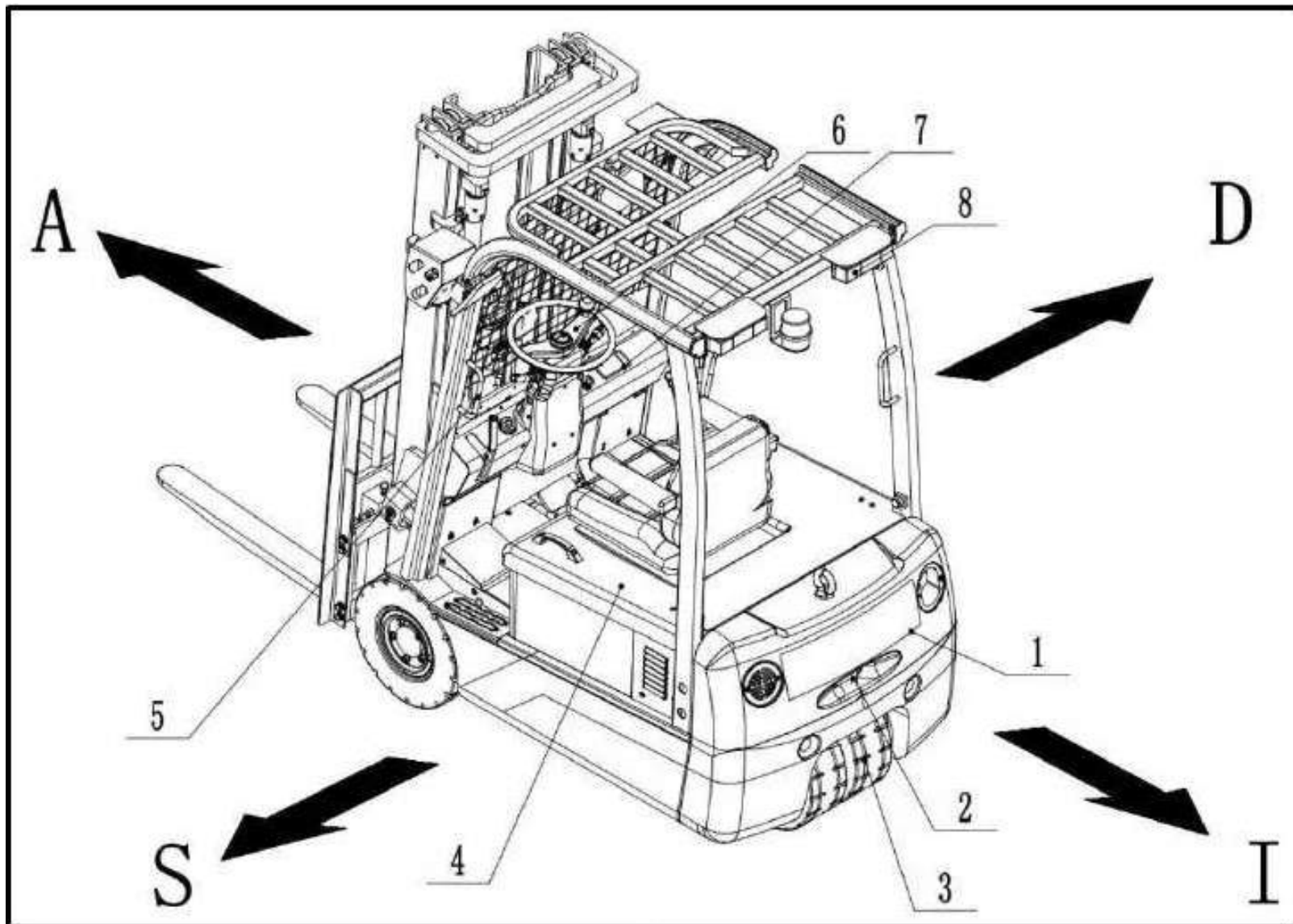

1. Ballast	7. Dashboard
2. Trailer coupling	8. Rear lights
3. Rear wheels	A. Forward
4. Battery cover	D. Right
5. Handle for climbing on/off	I. Backwards
6. Steering wheel	S. Left

Internal view

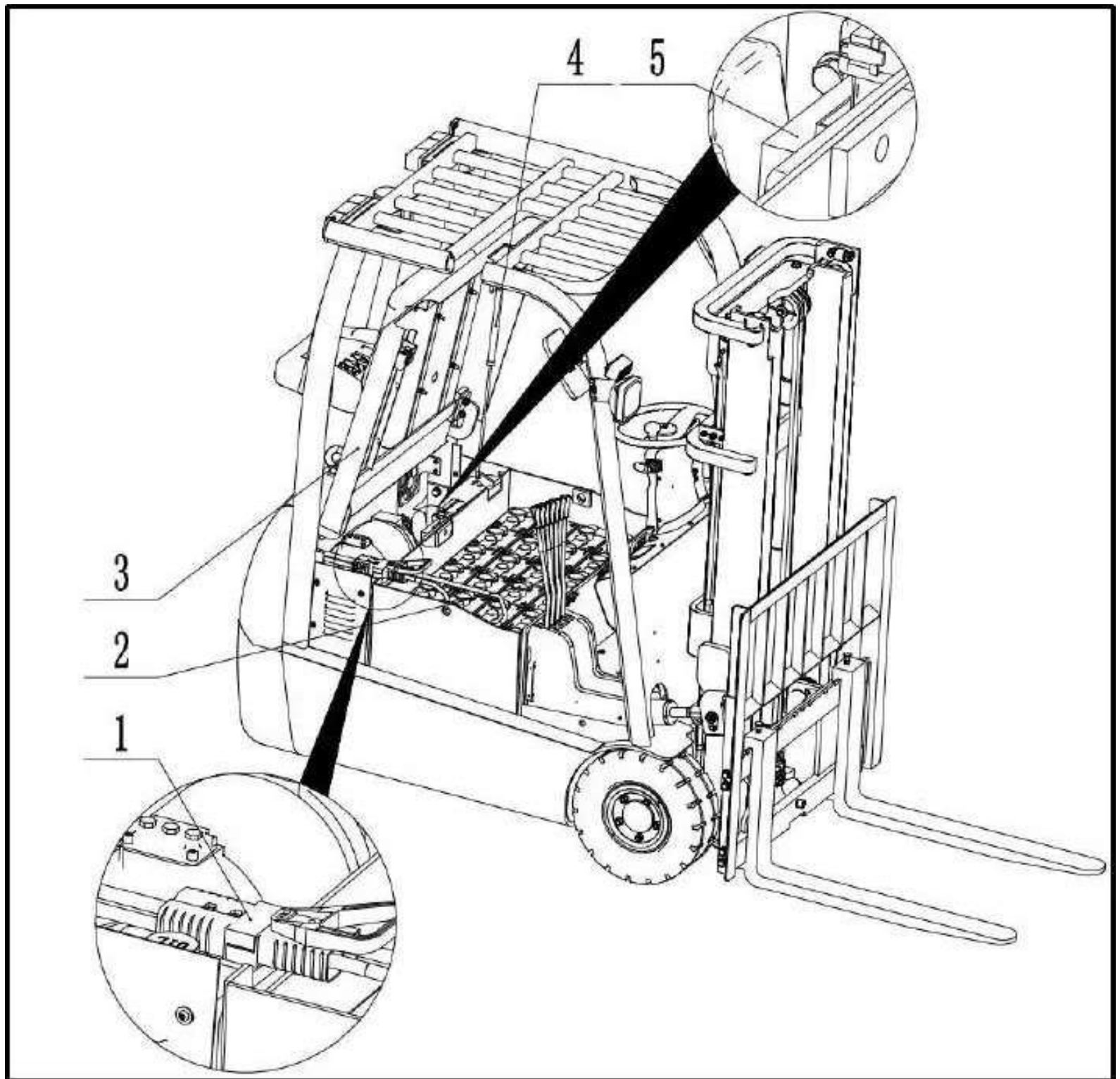

1. Battery plug /outlet	4. Hood support gas springs
2. Battery	5. Electronic panel
3. Battery cover	

Instrumentation and Controls

General view of dashboard

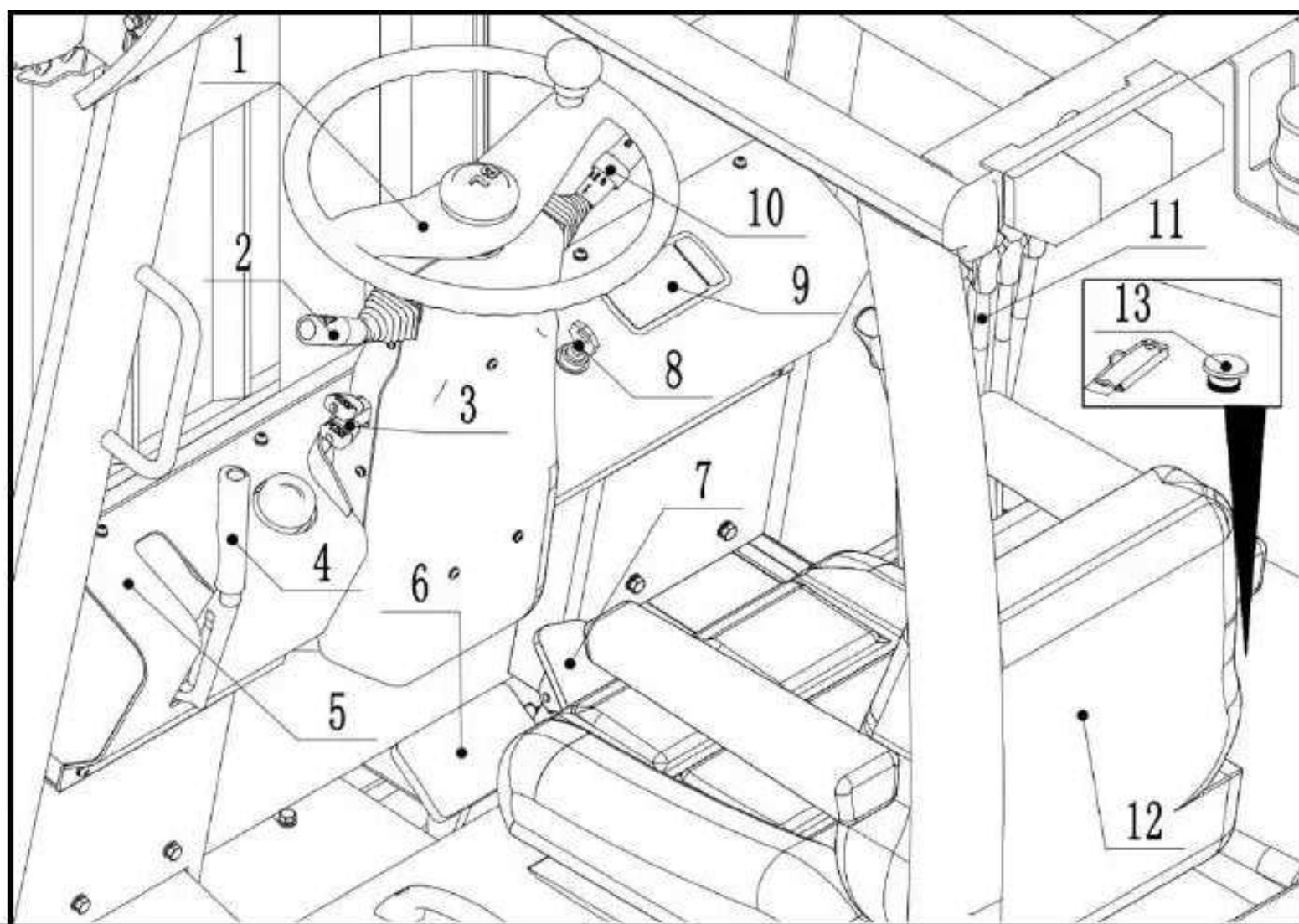

1. Steering wheel	8. Ignition switch with start key
2. Shift lever	9. Multifunction panel
3. Adjust lever, hand	10. Operating lever, turning lamps
4. Parking brake	11. Lift control levers
5. Control panel	12. Sit
6. Service brake pedal	13. Emergency stop button
7. Accelerator pedal	

Start/stop key

The switch has two positions:

0 = Circuit de-energised (Key removal position)

I = Live circuit

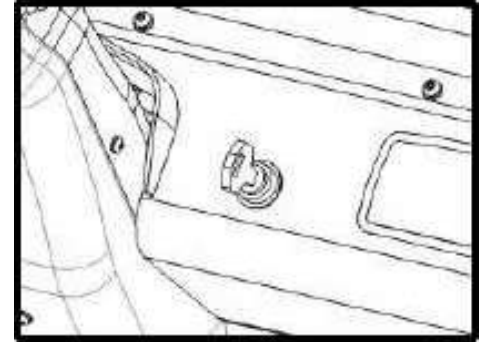

Combination switch for lights

Twist the switch to position 3 to turn off all the lights

Twist the switch to position 2 and move the switch hand shank to turn on the direction lights

Twist the switch to position 1 to turn on the floodlights

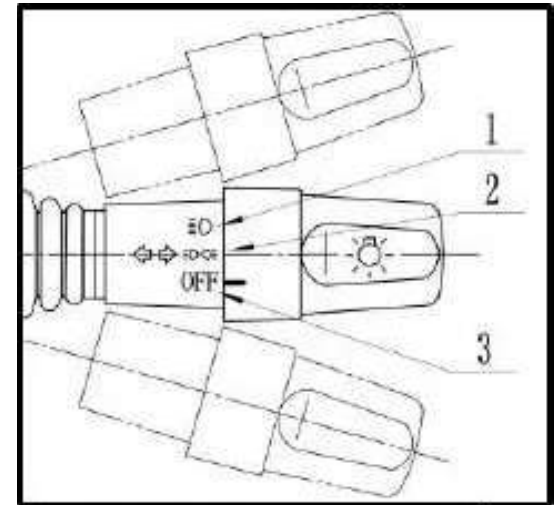

EMERGENCY STOP pushbutton

Pressing the pushbutton cuts off the power to the live parts of the truck.

CAUTION

This pushbutton must be used only in emergencies; repeated use of this device may cause problems with the electronic equipment.

Remove the cause of the emergency block.

Restore the functions of the forklift by proceeding as follows:

Turn the key of the switch to position "0";

Release the pushbutton by rotating it clockwise, and the button will release automatically.

Return the key of the switch to position "I".



NOTE

When restarting the truck, if anomalous behaviour or alarm messages recur, contact the Service department.

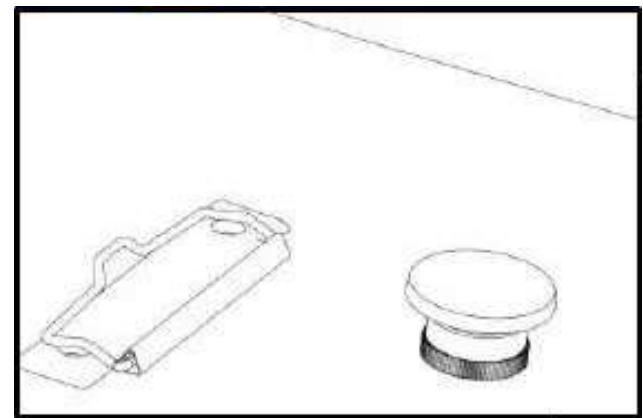

Distributor control levers

WARNING

The truck is equipped with a safety system that disables all the hydraulic functions when the operator is not seated on board.

- The functionalities of the levers are indicated by the label located on the top of the knob

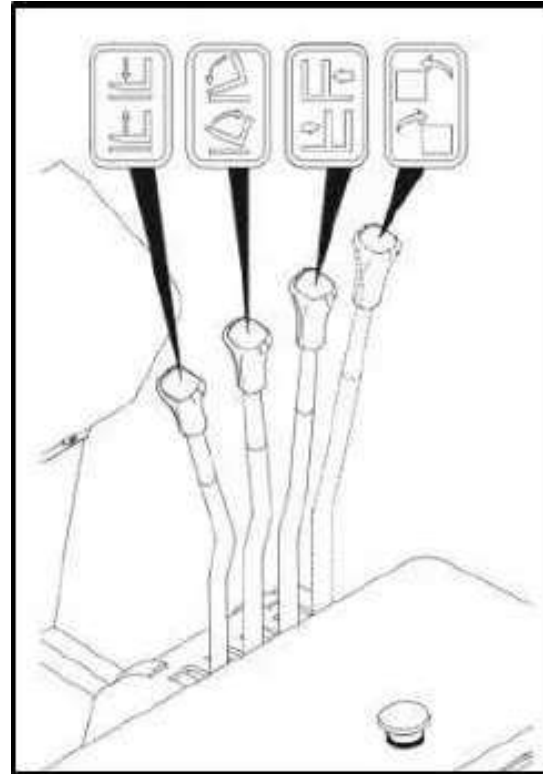

Lifting control lever

This lever controls the lifting of the fork arms and must be operated to raise or lower the load.

- To raise the fork arms, move the lever backward "B".
- To lower the fork arms, move the lever forward "A".

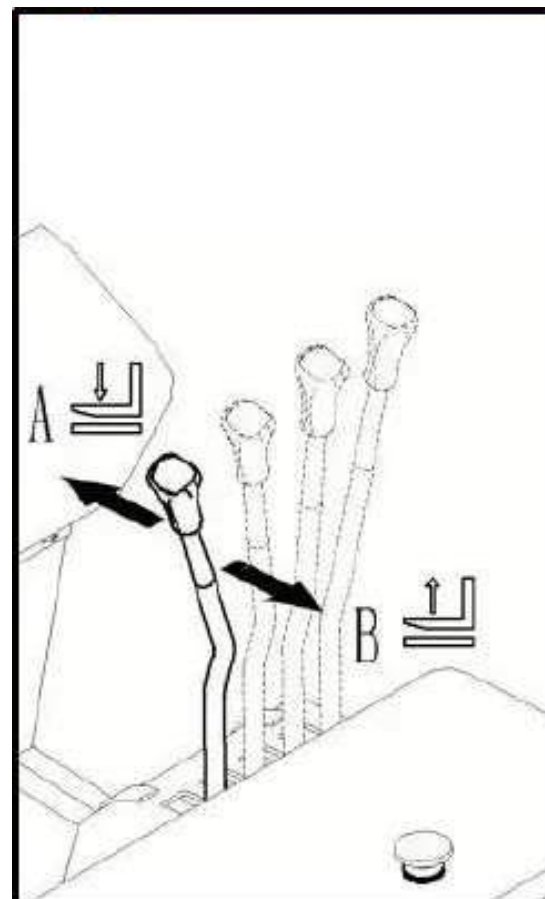

Lift inclination control lever

This lever controls the inclination of the lift "Tilt" and fork arms.

- To tilt the lift forward, move the lever towards "A".
- To tilt the lift backward, move the lever towards "B".

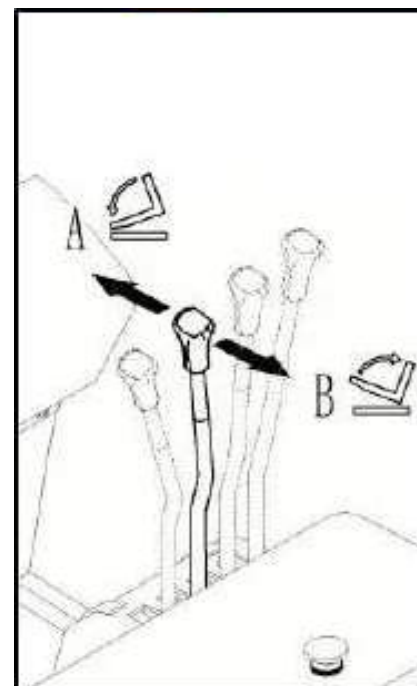

Side shift control lever (option)

This lever shifts the forks to the side. It is used to align the fork arms with the load pick-up or deposit position.

- To shift the fork arms to the left, position the lever forward "A".
- To shift the fork arms to the right, position the lever backward "B".

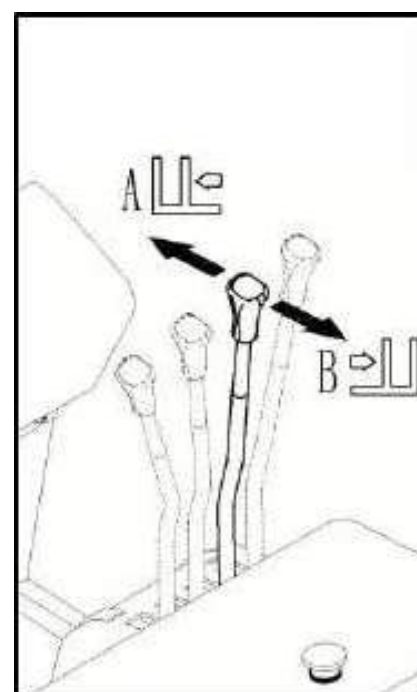

Supplementary equipment control lever (option)

This lever controls supplementary equipment. Its use will be indicated by special stickers.

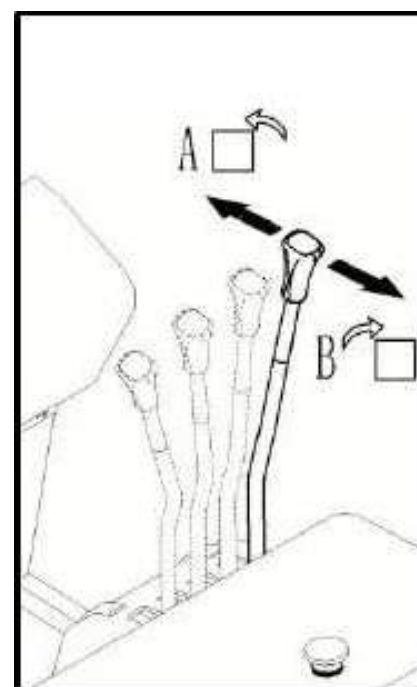

CAUTION

When a lever controls the opening or closing of a gripper, it must be equipped with a safety device to protect against accidental activation.

Horn

This device allows the driver to signal his presence when necessary. To sound the horn, press the button (1) located at the centre of the steering wheel.

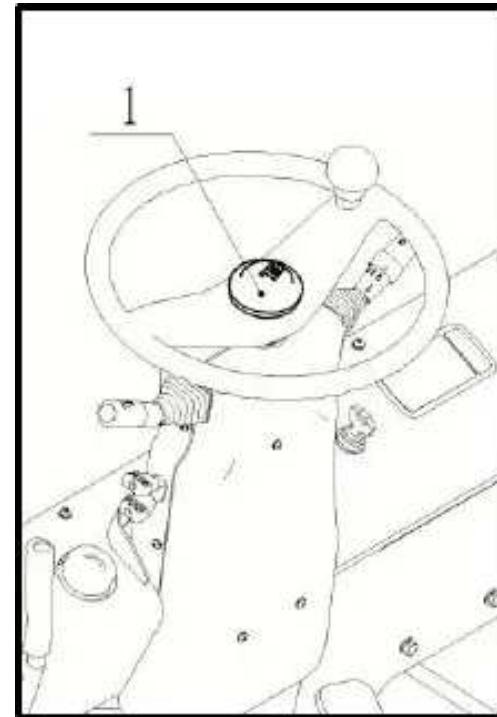

Parking brake

This device must be applied every time the operator steps off the truck

- To apply the parking brake, pull the lever (1) into position "A", making it travel at least 3 clicks. The corresponding indicator light on the control panel will light up.
- To release the parking brake, pull the lever further into position "A", press the button (2), and while keeping the button pressed return the lever to position "B".

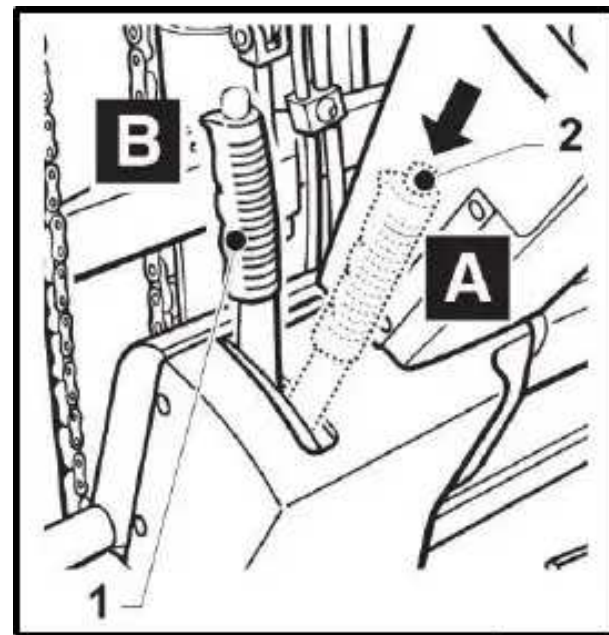

NOTE

A switch is located under the parking brake lever. This microswitch ensures that the truck cannot be operated when the parking brake is applied.

Service brake

The service brake pedal (1) is positioned next to the driving pedals. Pressing the pedal (1) causes the forklift to slow down until it stops.

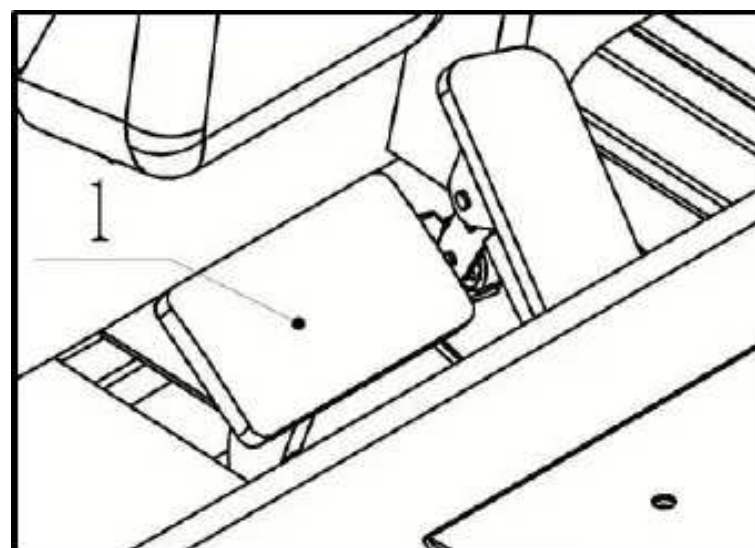

Reversing lever on the steering wheel and accelerator pedal

Reversing is performed using the lever (1) on the steering wheel and pressing the accelerator pedal (2).

Operated in position "A", the truck moves "FORWARD";

Operated in position "B", the truck moves "BACKWARD";

Positioned in the centre, the forklift remains in neutral.

CAUTION

Position the reversing lever in neutral before restarting the truck.

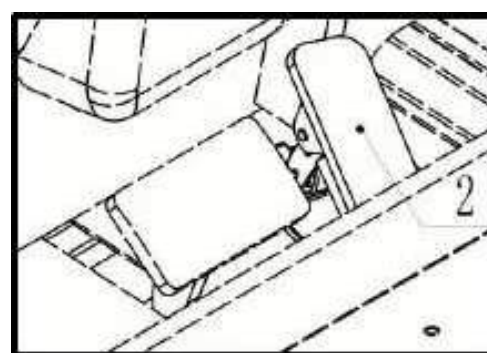
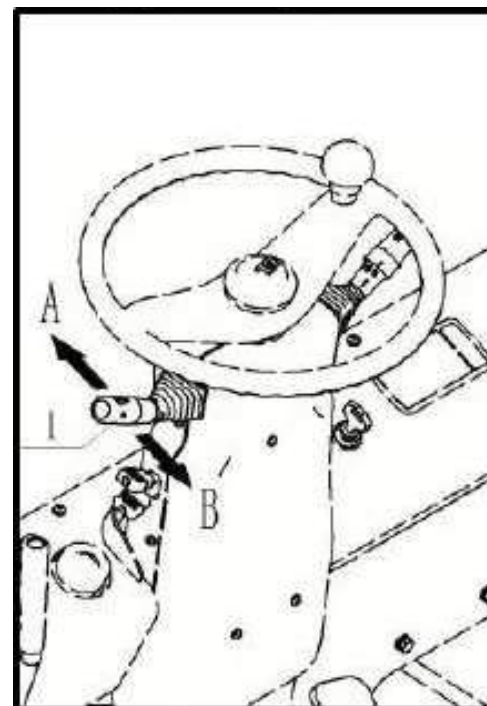

Adjustment of the steering wheel

To adjust the inclination of the steering wheel, loosen the shank (1) and adjust to the desired inclination, then tighten the shank.

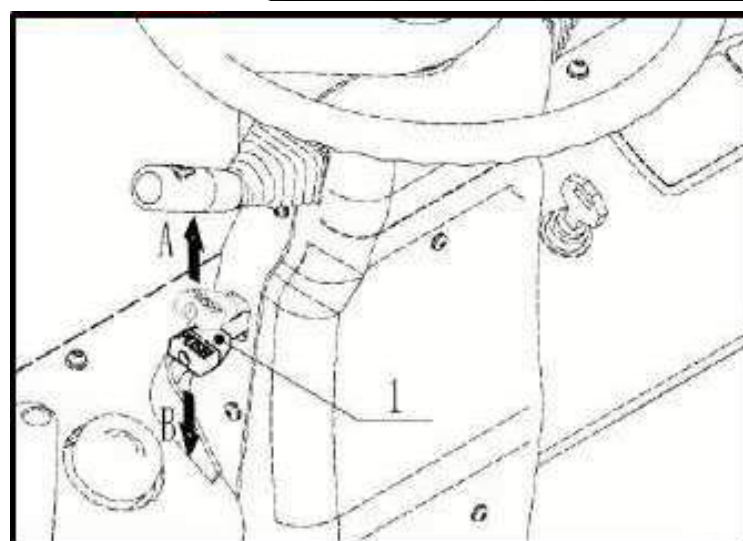

Adjustment of the seat BF1

The seat has three adjustments: the backrest inclination, the elasticity and the longitudinal adjustment.

DANGER

These adjustments must be performed with the forklift stationary

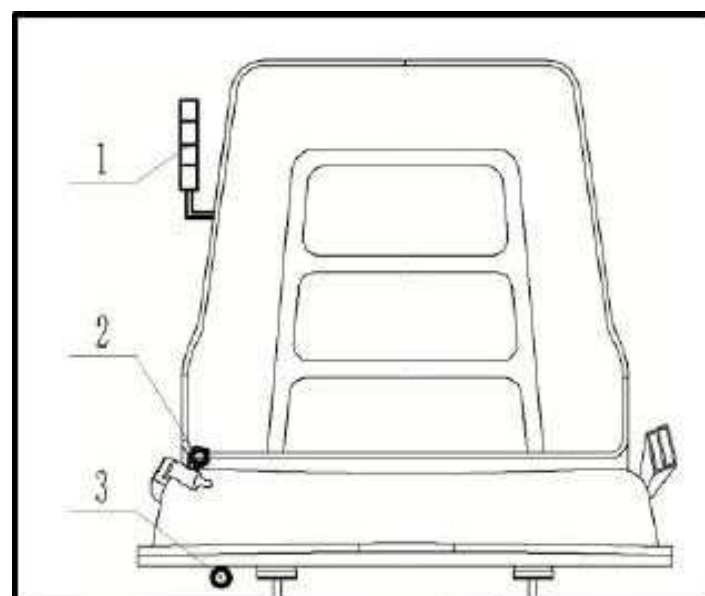

Inclination adjustment:

to adjust the inclination of the backrest, lift the lever (2) and move backwards or forwards in the seat until the desired position is reached.

Elasticity adjustment:

to adjust the shock absorber, operate the lever (1) and release it in correspondence with the user's body weight indicated on the graduated scale.

Longitudinal adjustment:

to adjust the seat longitudinally forwards or backwards, release the lever (3) located under the seat.

Seat belt BF1

- To fasten the seat belt, extract the locking plate (2) with a regular movement from the winder (1) and take it to the buckle (3) of the coupling (4).
- Insert the locking plate (2) into the buckle (3) until a click is heard.

NOTE

Make sure that the belt is not twisted. Ensure that the winder takes up any slack of the belt. If the winder blocks before being able to secure the locking plate, do not force the belt but rewind it completely and repeat the operation.

When the belt is fastened, pull the belt briskly to check the intervention of the blocking device of

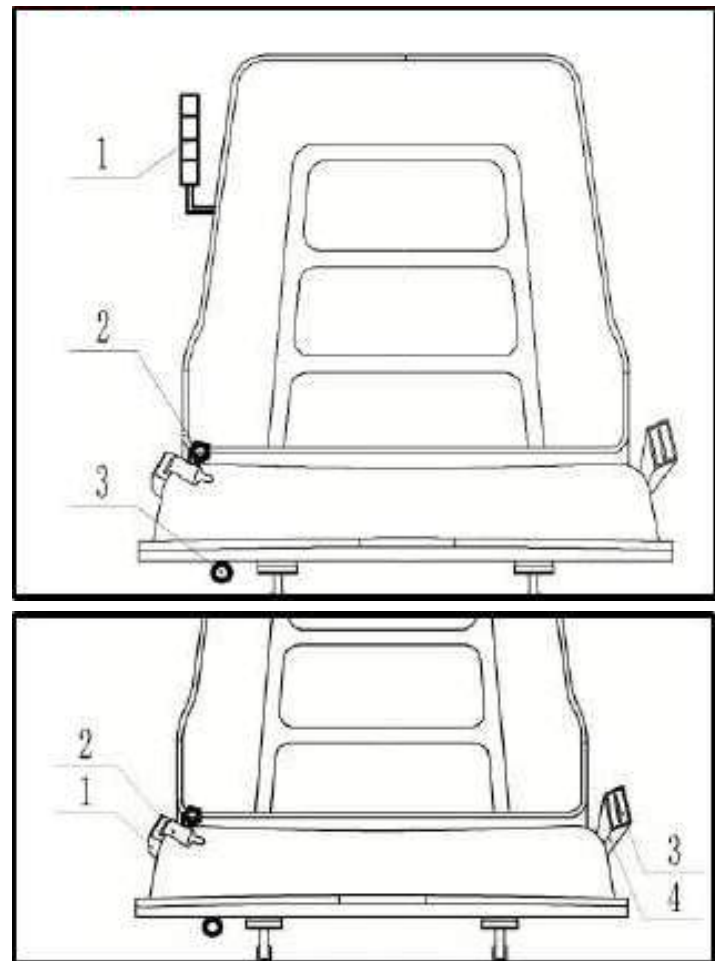

the winder. If the blocking device does not intervene, have the belt checked by specialized personnel.

DANGER

The belt must not pass over blunt or fragile objects contained in the pockets as this may cause problems. Do not place objects between the operator's body and the belt. Avoid passing the belt over rough or sharp surfaces.

- To release the belt, press the red button on the buckle and return the belt with the hand as it rewinds automatically.



DANGER





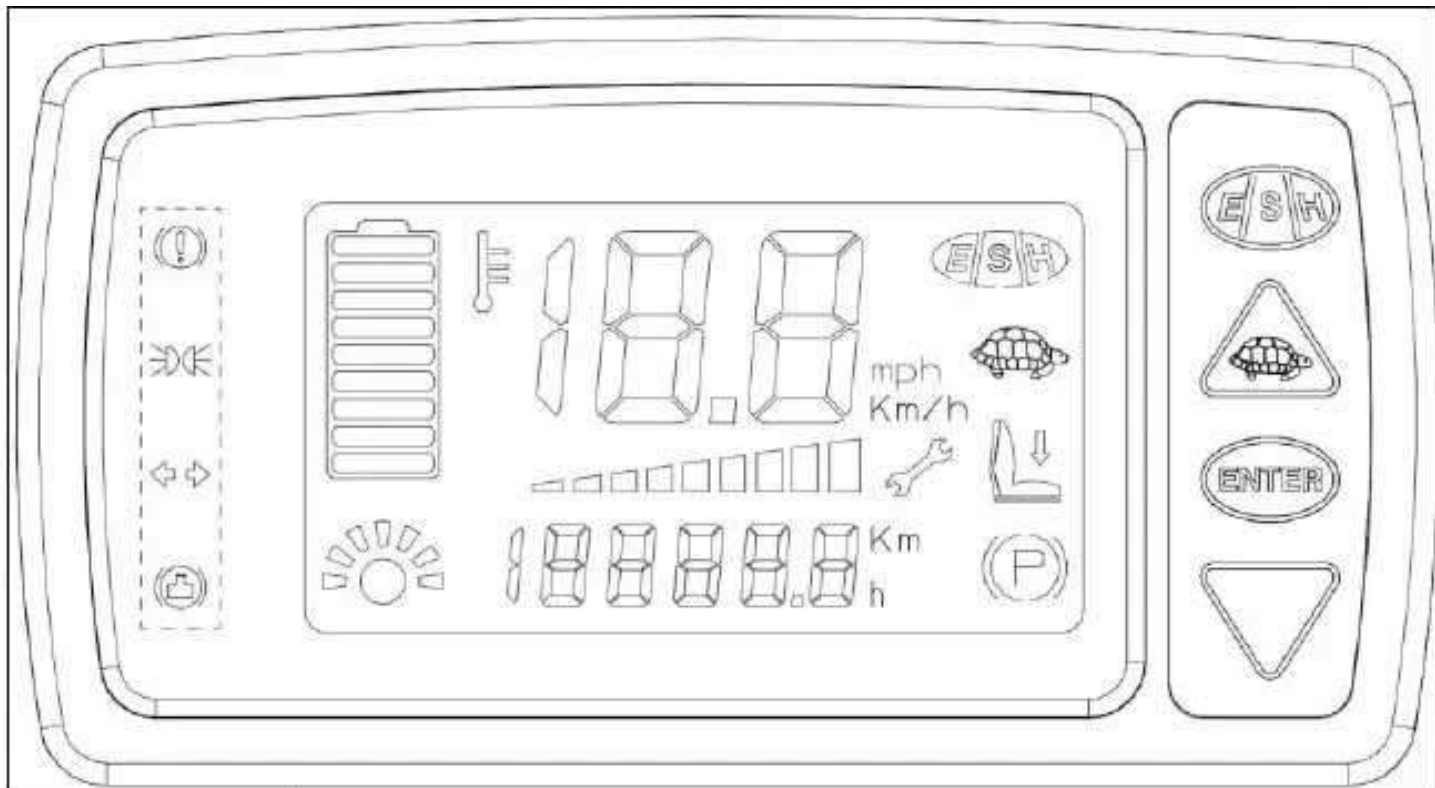

Belts that are cut, frayed or in any case ruined or mounted on vehicles that have been in accidents must be replaced. Always replace the entire restraint system: belt, buckle, and winder.

* In Italy it is necessary to refer to and comply with Lgs. D. 626/94 and, in particular, the "LINEE GUIDA ISPESL DI ADEGUAMENTO DEI CARRELLI ELEVATORI IN RIFERIMENTO AL RISCHIO DI PERDITA ACCIDENTALE DI STABILITA'" (ISPESL Guidelines for forklift protection against accidental loss of stability) available on the site "www.ispesl.it/ispesl/sitodts/Linee_guida/linee_guida/linee_guidanew.html"

Multifunction panel

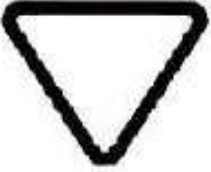

15.9	Traveling speed (km/h)
(P)	Hand brake switch, lamp lights when pulling the hand brake
	With safety seat switch open, meter indicates seat symbol, main contactor can't be connected and truck can't travel until seat switch closes.
15888.8	Time meter (Odometer)
	Turning angle, indicating the position of rear wheel

	<p>Maintenance time indication</p> <p>Remind the users to maintain and service the forklift truck.</p>
	<p>Slow-speed operating</p> <p>With the lamp on, the traveling speed and lifting speed will be reduced in slow-speed mode.</p>
	<p>Traveling speed (Indicated from “0-9”)</p>
	<p>Overheated motor temperature warning</p>
	<p>Battery level (indicated by 9 segments)</p> <p>Display signals with alarm code 12 when battery is completely discharged.</p> <p>Charge the battery when indicating on 1 segment.</p>
	<p>Press E-S-H button, you can set operating mode for system. (E-economic mode, S-midrange mode, H-high mode)</p>
	<p>H-High mode: High acceleration, decelerate rate, max. grade ability, suitable for loading large quantity goods in short time and climbing abrupt slope, this mode wastes electricity, only used when necessary.</p>
	<p>S-Midrange mode: The parameter lower than High mode</p>
	<p>E-Economic mode: The parameter has been optimized. Working on this mode in general for saving electricity.</p>
	<p>1. Start the key switch, press ENTER button for 3 seconds, enter into adjust and diagnosis mode.</p>
	<p>2. When operating, press for 3sec, enter into diagnose mode.</p>
	<p>3. Quit when pressing ENTER under diagnosing mode, the enter key is used for setting new parameter.</p>
	<p>1. Reduce the parameter in adjusting mode when pressing this key.</p>
	<p>2. The parameter can be reduced in adjusting mode.</p>
	<p>3. Press the key for 1sec, indicating mileage or weight.</p>
<p>Note: The function of Up key is same to down key, enter, up and down key have some functions not activated.</p>	

The multifunction panel is the interface between truck and operator. It displays information on the display, and some adjustments can be made using the respective pushbuttons.



NOTE

At a subzero environment, the display may not indicate any signal. This does not preclude normal operation of the truck, but the display of the alarms is blocked.

Fault code	Description	Fault code	Description
1	Max. battery voltage	2	Min. battery voltage
3	Pedal trimmer fault	5	Eeprom alarm
6	Pre-charge	8	Power
		25	
9	Inverter	11	Capacitors
12	Low battery voltage	13	Over-heating motor
		19	
15	Motor current offset alarm	17	Main breaker
16			
18	Watchdog timer alarm	20	Power inverter over-heating
		22	
37	Alarm on 5V encoder voltage	38	Alarm on 12V output voltage
50	Pump motor commands active on start	61	Motor blocking over-heating
		62	
		65	
63	Seat switch open on start	64	Wrong start
74	Encoder alarm	77	Motor thermal sensor alarm
75		78	
80	Inverter temperature alarm	83	CRC fault alarm
81			
84	Bank CRC restored	90	Steering sensor alarm
91	Brake pedal switch alarm	98	Capacitors pre-charge too slow
99	Capacitors pre-charge timeout		



DANGER

Call the service department for all alarms not indicated in the previous list.



DANGER

If, when eliminating the cause of the alarm, the alarm persists, contact the authorised sales and service network.

Forklift identification

Location of data plates

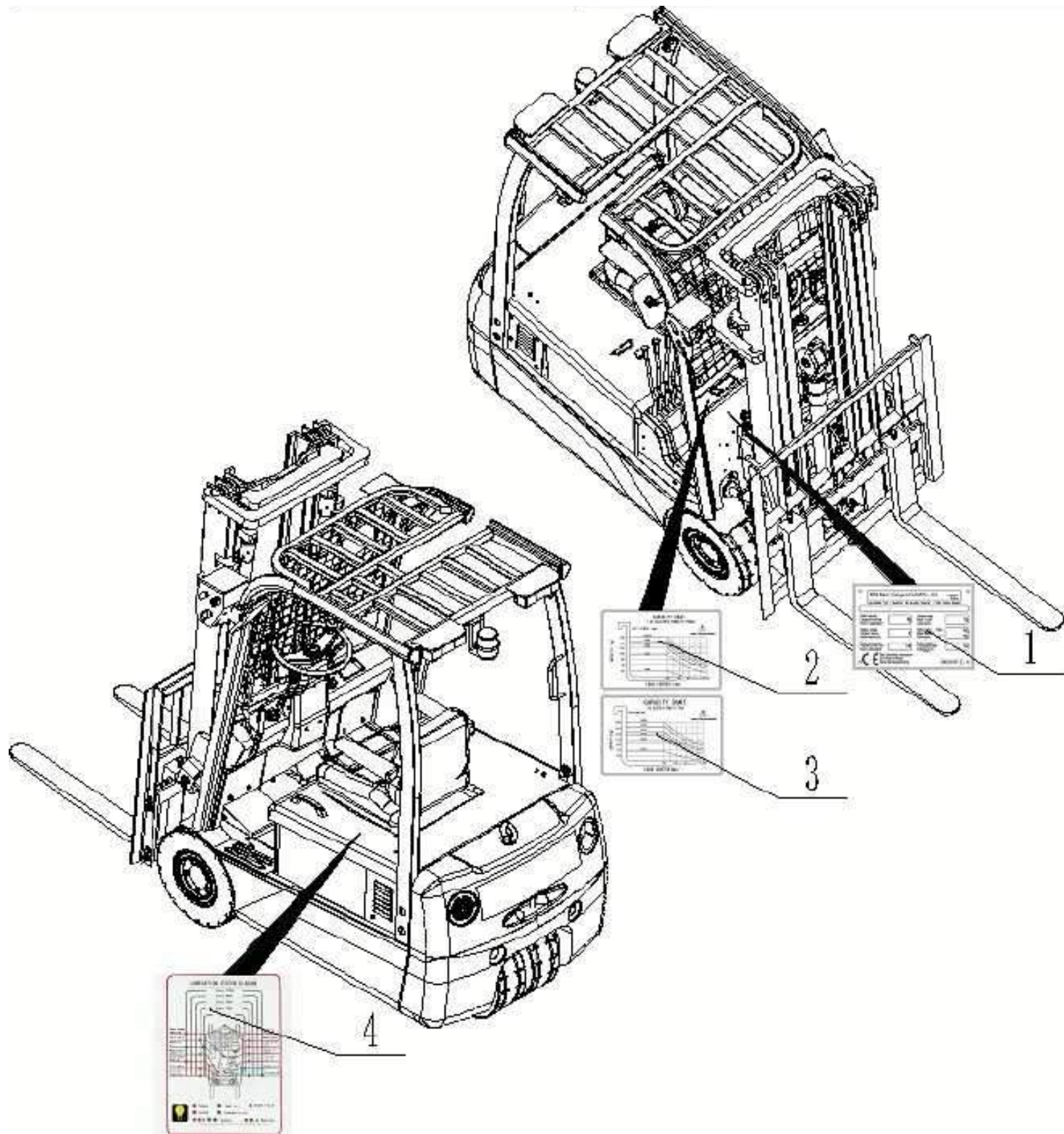

1. Forklift identification plate	3. Capacity plate for 1.8T forklift without equipment
2. Capacity plate for 1.5T forklift without equipment	4. Lubricant plate

- The forklift and its main components are identified by serial numbers that make it possible to recognize them.
- The serial numbers must be supplied to the dealer in the case of maintenance interventions or spare parts requests.

Chassis punching

- The chassis number (1) is stamped on the truck structure on the partition indicated by the picture.



NOTE

The user must verify the presence and legibility of each of the plates. Contact the authorized sales network if the plates are worn or damaged

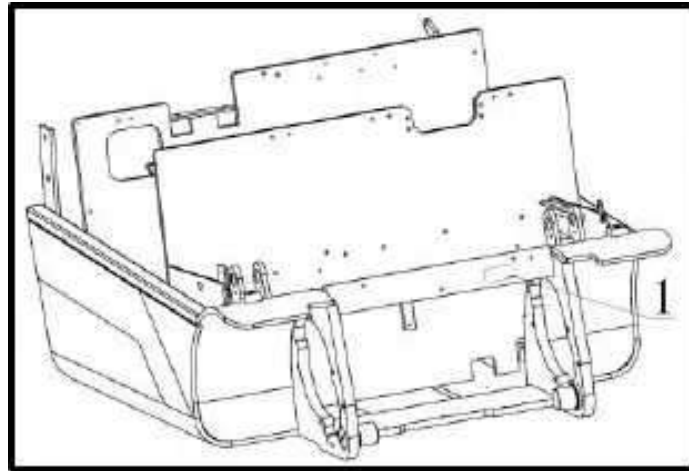

Forklift identification plate

The capacity plate indicates the following data:

- A = Type of forklift
- B = Nominal load capacity
- C = Serial number
- D = Year of manufacture
- E = Empty mass without traction battery
- F = Traction battery voltage
- G = Minimum traction battery mass
- H = Maximum traction battery mass
- I = Rated drive power
- J = Ballast weight

SHANTUI		No.58 Highway G527 Jining, Shandong China	
Type - Modèle - Typ / Serial No. - No. de série - Serien-Nr. / Year - Année - Baujahr			
Rated capacity Capacité nominale Nenn-Tragfähigkeit	<input type="text"/> kg	Unladen mass Masse à vide Leergewicht	<input type="text"/> kg
Battery voltage Tension batterie Batteriespannung	<input type="text"/> V	max. * <input type="text"/> kg	<input type="text"/> kg
Rated drive power Puissance motr. nom. Nenn-Antriebsleist.	<input type="text"/> kW	* <input type="text"/> kg	<input type="text"/> kg
		* See Operating Instructions Voir Mode d'emploi Siehe Betriebsanleitung	
		Produced in China 00093861XX	

Capacity plate

The lift plate indicates the following data:

- A = Type of forklift
- B = Lift Height
- C = subtraction with side shifter
- D = Load centre-of-gravity

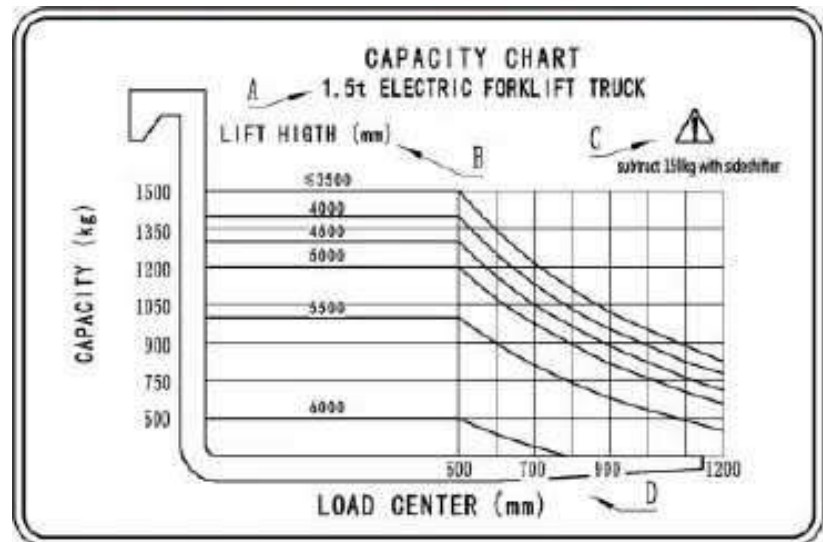

Lubricants plate

The data on the lift plate are as follows:

- A = Hydraulic system oil
- B = Front axle and gearbox oil
- C = Greasing

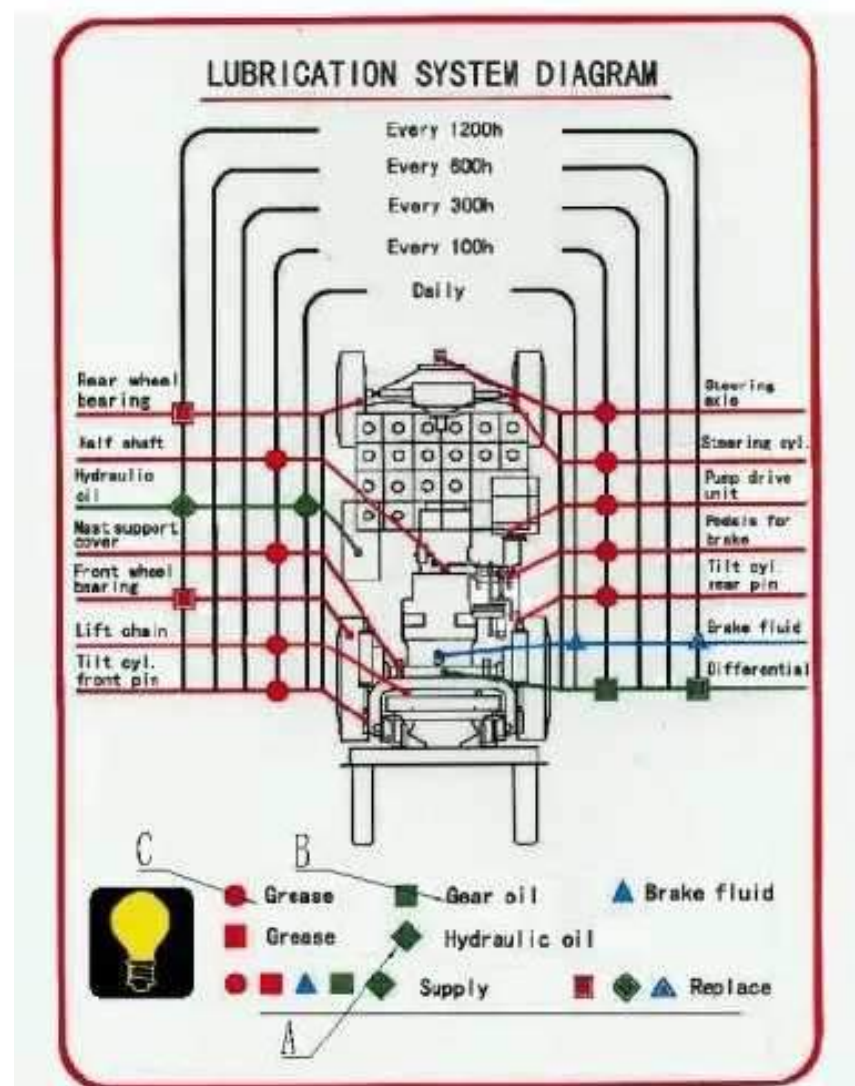

Use and Operation

Forklift Transport and Lifting

Transporting the Forklift

The forklift is normally transported by truck and train complete with hoist. If the forklift's dimensions exceed the max. clearance size allowed, it is transported disassembled. The sales network is in charge of the disassembly and reassembly operations. The forklift must be secured to the transport means during transport using appropriate restraint systems. Block the wheels with wedges to prevent even the slightest movement.

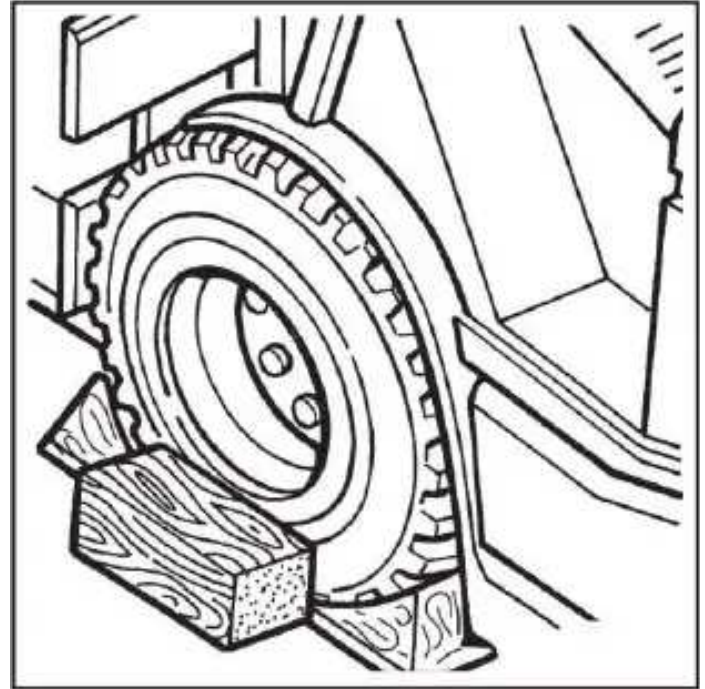

Environmental Conditions for Transport and Storage

The forklift must be protected from atmospheric agents during transport and storage, and it must be suitably protected in salty environments.

Loading and unloading the truck

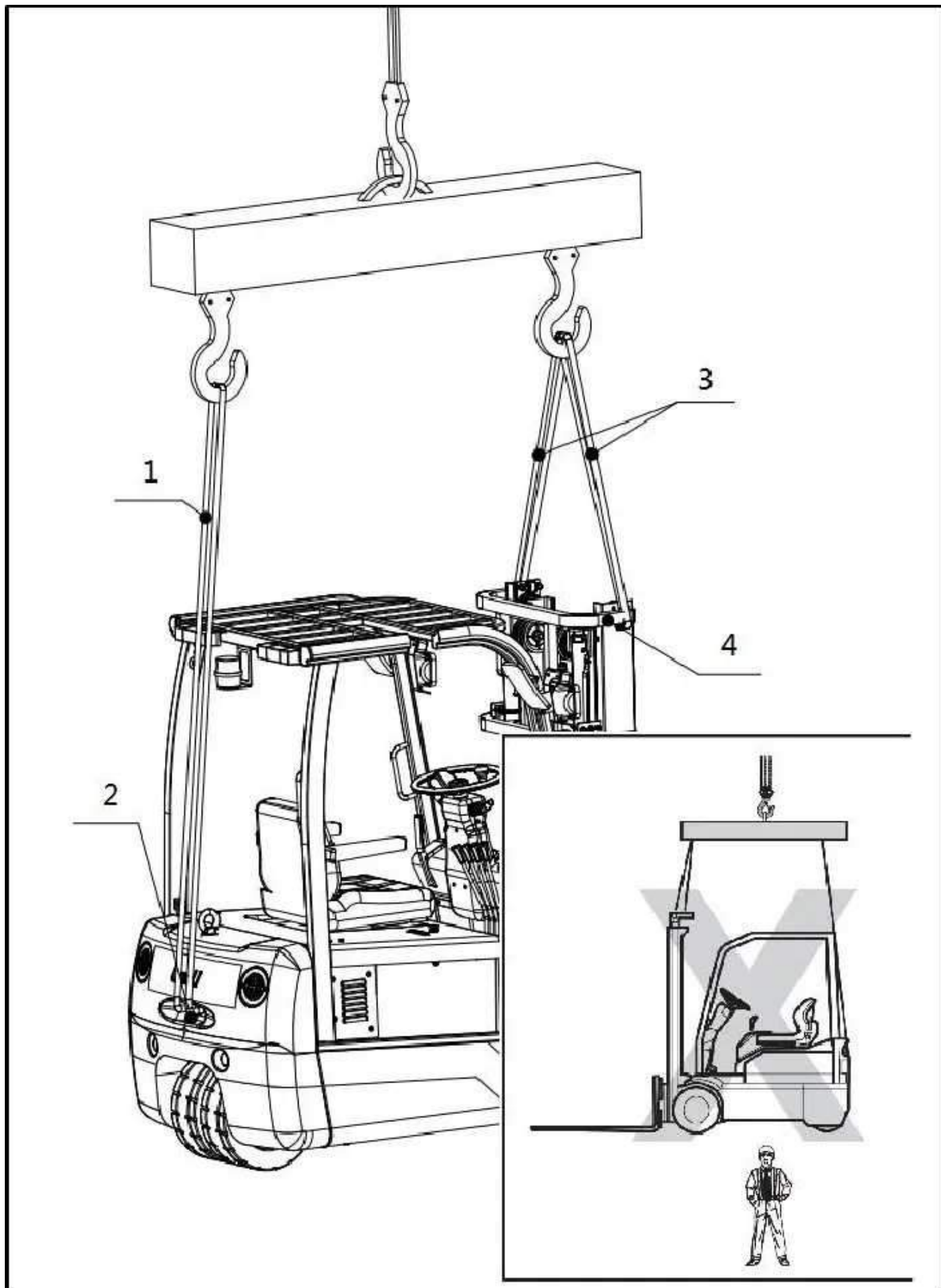

Use an inclined plane or movable loading ramp to load and unload the truck. If the truck is not operational or does not have the battery, lift it as described below.

DANGER

Use a crane with a suitable lifting capacity for the weight of the truck, indicated on its designation plate. Also take into account the weight of the mounted battery (if applicable), consulting the relevant designation plate. The lifting operations must be performed by qualified personnel. DO NOT stand within the crane's radius of action or near the forklift. Use non-metallic cables. Make sure that the lifting capacity of the slings is suitable for the weight of the truck.

To lift the truck, proceed as follows:

- Insert a non-metallic sling (1) into the rear tow coupling (2) of the truck. Check that the sling adheres to the upper part of the slot in the counterweight.

Commissioning

DANGER

Do not use the forklift before it has been commissioned by the technical support service authorized by the manufacturer.

Breaking-In

This type of forklift does not require special breaking-in operations.

- Pass two slings (3), one on each side, through the upper cross member (4) of the lift's fixed mast.
- Connect the free ends of the cables to the hook of the crane and lift without tearing.

CAUTION

The cables should have a suitable length so as to not graze the roof or any additional equipment during lifting. Use a lifting beam if necessary. The slings must be pulled vertically.

CAUTION

Any other lifting and transport method of the forklift is forbidden.

CAUTION

The forklift must be commissioned exclusively by the technical support service authorized by the manufacturer.

Daily checks before use



CAUTION

It is a good rule to perform the checks listed below on a daily basis to keep your forklift in good condition. These checks supplement and do not replace the scheduled maintenance operations.

- Visually check the correct positioning and fastening of the various truck safety components illustrated in the "Safety devices" paragraph: overhead guard, shear protection net (if applicable), load rack, fork stop blocks, fork retaining device, chain retaining device, chain tension rod retaining device, fork carriage retaining device. etc.
- Check that the "seat switch" sensor works correctly.
- Make sure that the seat belt works correctly.
- Make sure that the brakes work correctly, checking their travel and efficiency.
- Make sure that the horn and the reverse gear warning buzzer work correctly.
- Check the tyre pressure and wear conditions.
- Make sure that the lights work correctly (if applicable).
- Visually check that the chains are taut.
- Check the automatic return to neutral position of the Joystick
- Check the battery electrolyte level and density (see battery manual).
- Check that the emergency stop pushbutton works correctly.

□ Make sure that the battery air vent (A) located under the seat is not obstructed. Remove any rags or other objects that may obstruct correct ventilation of the battery.

DANGER

The battery emits a potentially explosive mixture of hydrogen and oxygen when charging, working and in motion. Risk of explosion

CAUTION

DO NOT use the forklift, but call the technical service department, if you notice any malfunctions or if you have any doubts about its correct operation.

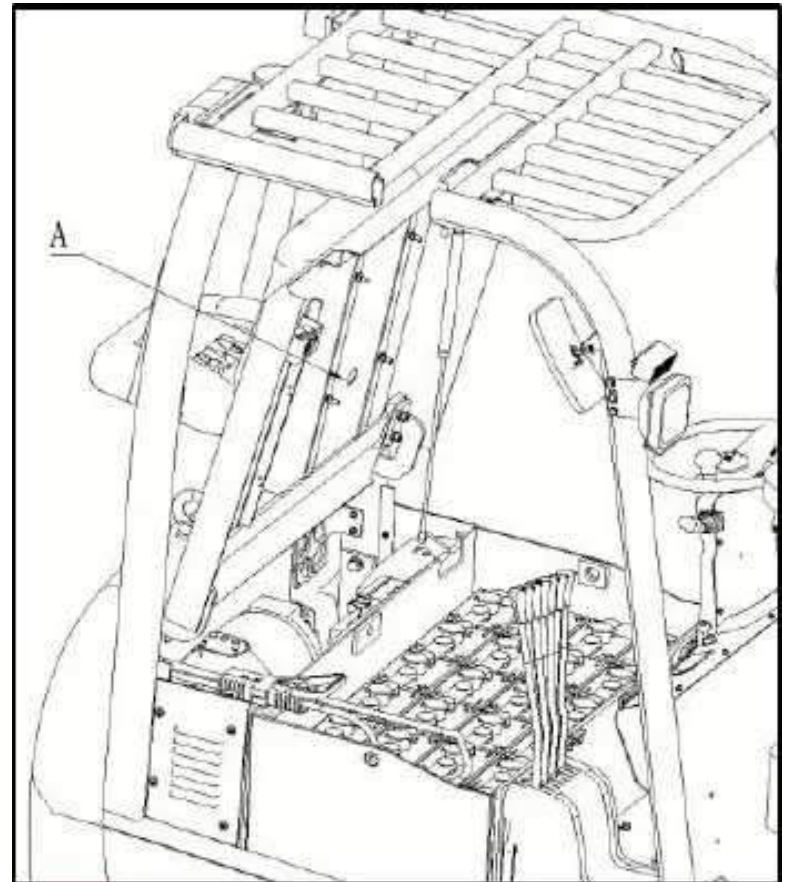

Use of truck

Stepping on/off the truck

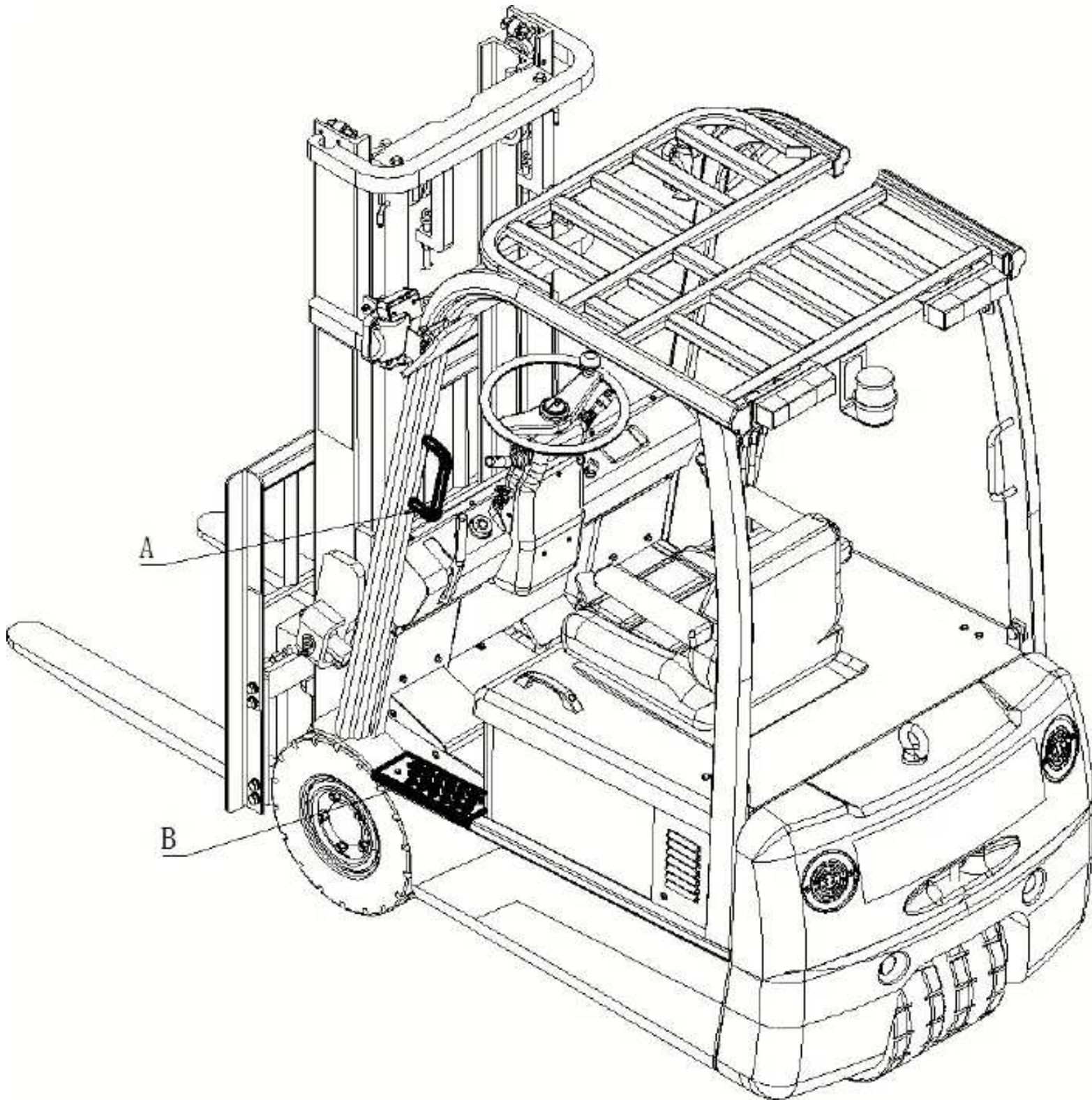

After having performed the daily checks, carry out the following operations to use the truck:

- Step on to the truck from the left-hand side by placing your left foot on the non-slip step plate (B) while gripping the handle (A) with your hand. For versions with cab (option), open the door using the respective handle/pushbutton and step on to the truck as described previously.
- To step off the truck, in versions with cab open the door using the handle or pushbutton, and for all versions use the step plate (B) and handle (A).

Starting the forklift

Perform the 3 following steps:

- Sit correctly on the seat
- Check the emergency pushbutton
- Insert the key

Sit correctly on the seat

- Sit on the seat and fasten the seat belt; if the truck has a closed cab, check that the door is closed before starting the truck.



NOTE

There is a sensor on the seat that detects the presence of the operator when seated on the driver's seat. Activation of this sensor enables operation of the truck.

Check the emergency pushbutton

Check that the EMERGENCY stop pushbutton (1) is not pressed.

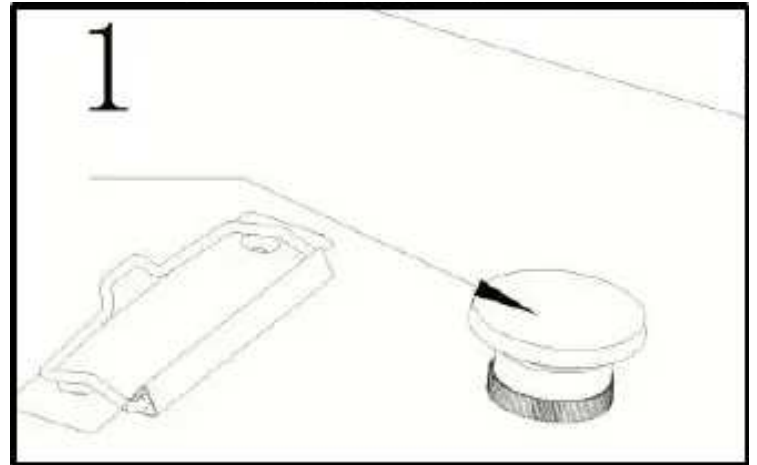

Insert the key

Insert the key (2) and turn it to position "I". The display lights up, indicating that the electrical circuits are operating.



NOTE

The electronic equipment performs a check on the sequence of truck starting operations. Any actuations during this phase (e.g.: accelerator pedal, lift lever, etc.) will generate alarm signals.

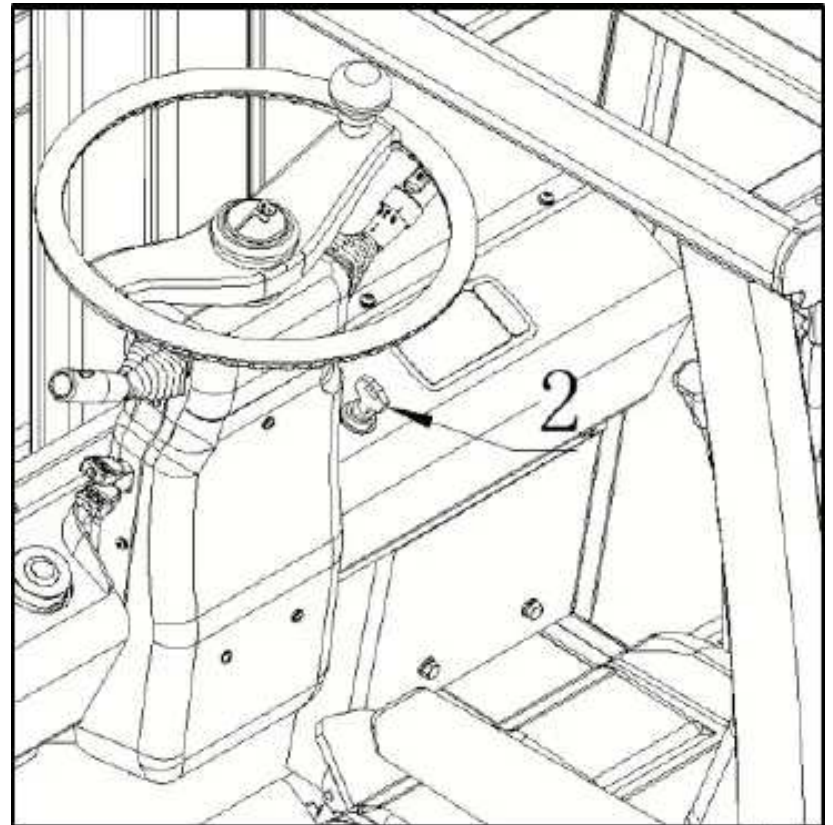

Forklift operation

- Release the parking brake (1), and the relative LED (2) will turn off.

NOTE

For all driving conditions, check that the fork arms are raised at least 5 cm above the ground and that the lift is tilted backwards.

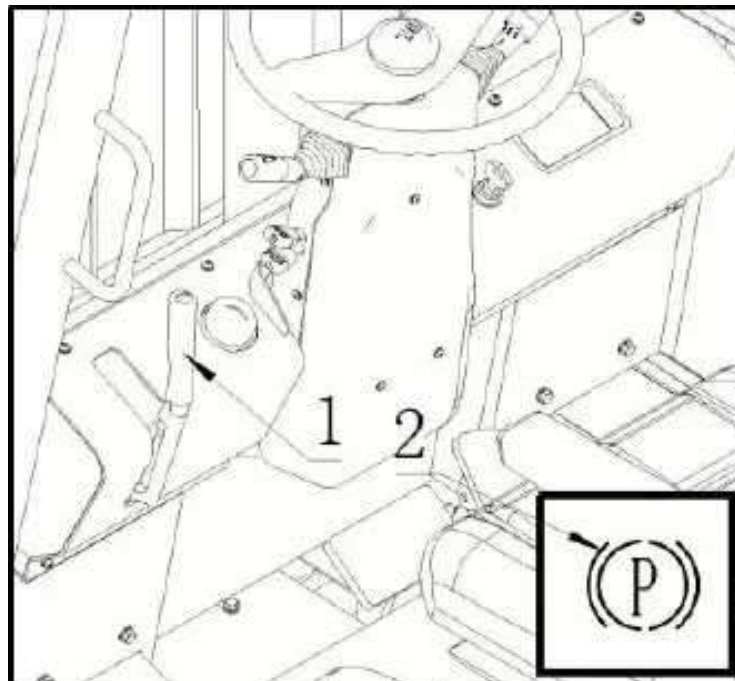

- Move the lever to the desired direction of travel (A or B), then press the accelerator pedal (1).

NOTE

When driving in reverse, the reversing lights are turned on automatically and the acoustic reversing signal is activated.

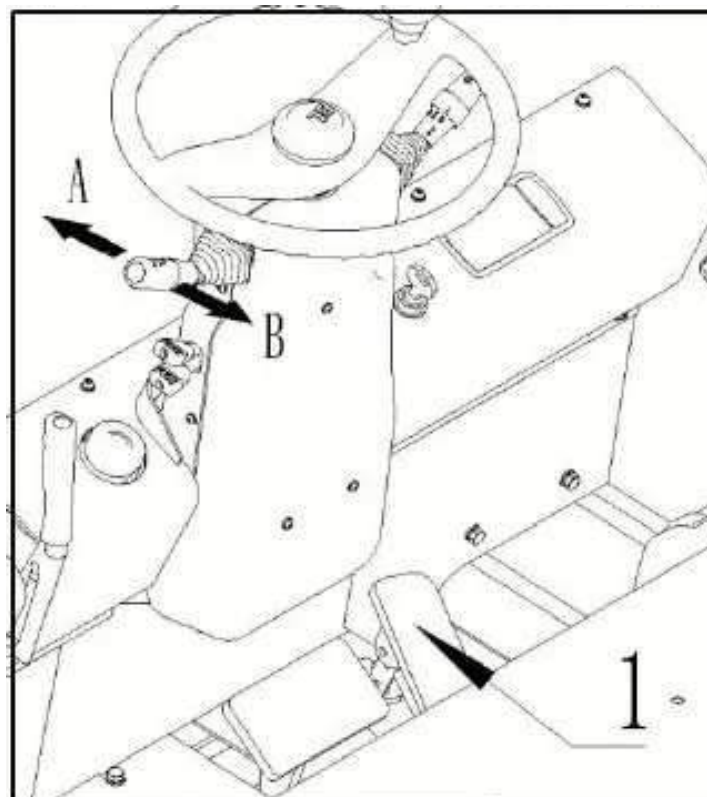

NOTE

If the truck has difficulties in starting to move, check that there are no alarms in progress; do not force the truck, but search for the cause.

Changing direction of travel

- Driving without load
 - If it is necessary to reverse direction of travel while driving without a load on the fork arms, this operation can be performed rapidly without using the service braking by moving the lever from the current position to the new position.
- Travelling with load
 - To reverse direction of travel when there is a load on the fork arms, release the accelerator pedal (1) then press pedal (2) of the service brake until the forklift comes to a complete stop.
 - Using the steering wheel reversing lever and press the accelerator pedal.

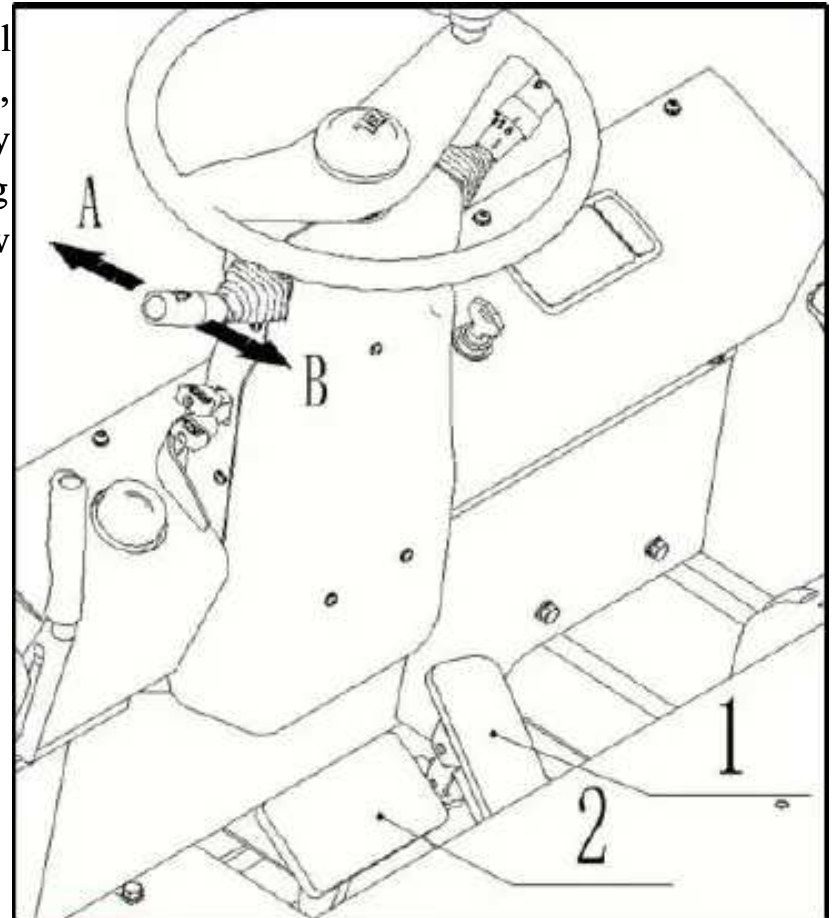

DANGER

Reversing direction of travel with a load without completely stopping the truck can result in shedding its load.

Forklift Braking/Stopping

- To stop the truck, release the accelerator (1) .
- Press the service brake pedal (2) progressively until the truck comes to a complete stop. The stop lamps turn on in the rear lights unit.
- Block the forklift by applying the parking brake (3).

 **DANGER**

NEVER LEAVE the truck without having first applied the parking brake (3) and removed the key

NEVER LEAVE the truck on a slope. If the truck must be left on a slope, suitable wheel chocks (4) must be positioned under the front wheels.

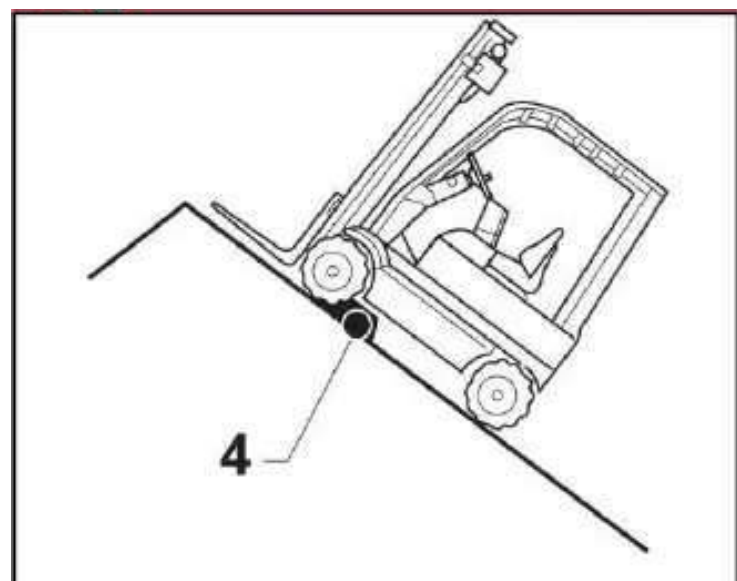
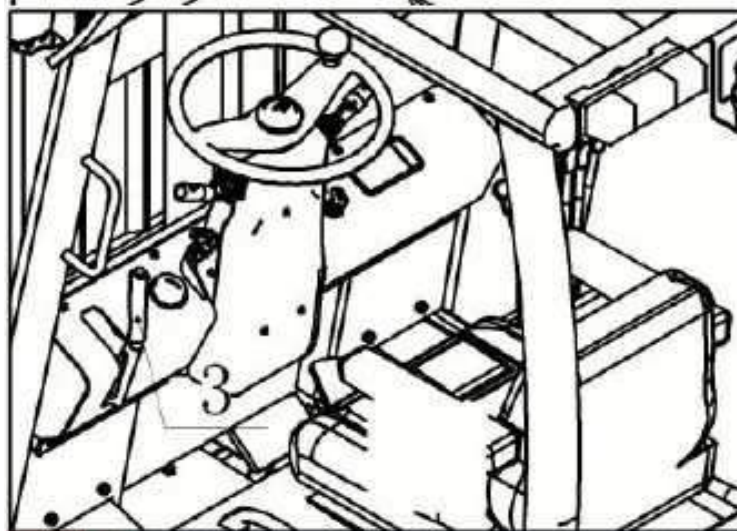
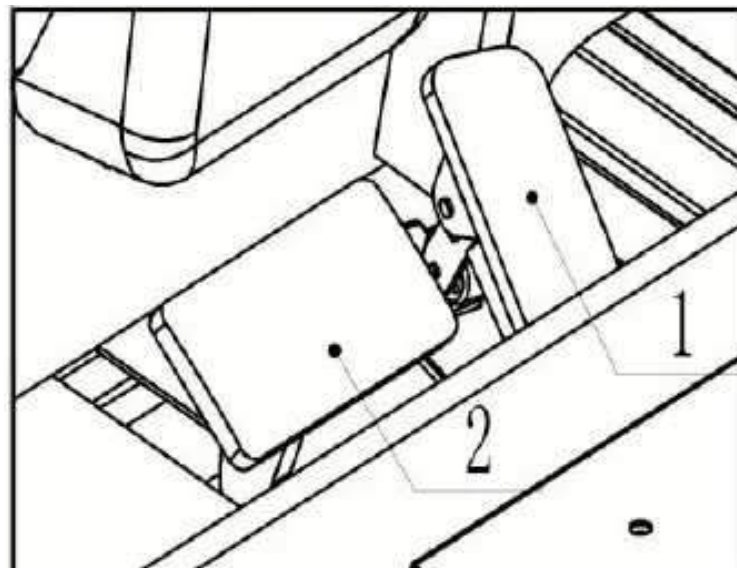

Leaving truck

- When leaving the machine, lower the forks to the ground.
- Block the forklift by applying the parking brake (3).
- Turn the truck off by turning the key (2) to position "0", and remove the key from the panel.

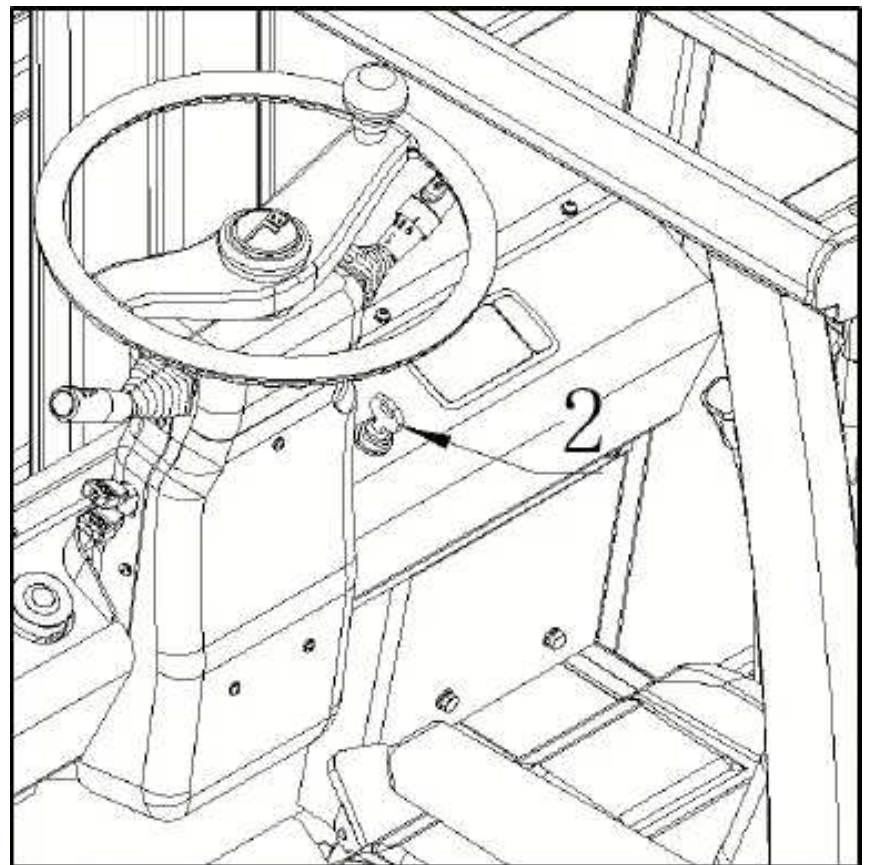
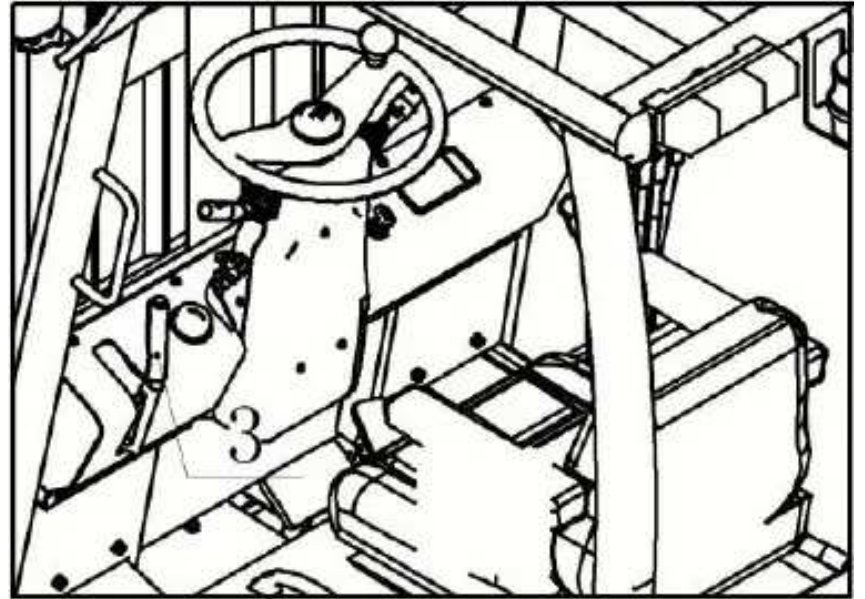

Steering the forklift

A special viewer (1) on the display indicates the position of the wheels by means of seven marks, indicating the steering direction to the operator. When the central reference mark "C" is blackened, the truck is steering straight ahead

NOTE

Depending on the positioning of the rear wheels and whether the accelerator pedal is pressed, the respective marks on the display light up.

- With the right mark "C" blackened: the lever at "A" position pressing pedal (1) causes the truck to rotate anticlockwise "A"; the lever at "B" position causes the truck to rotate clockwise "B".

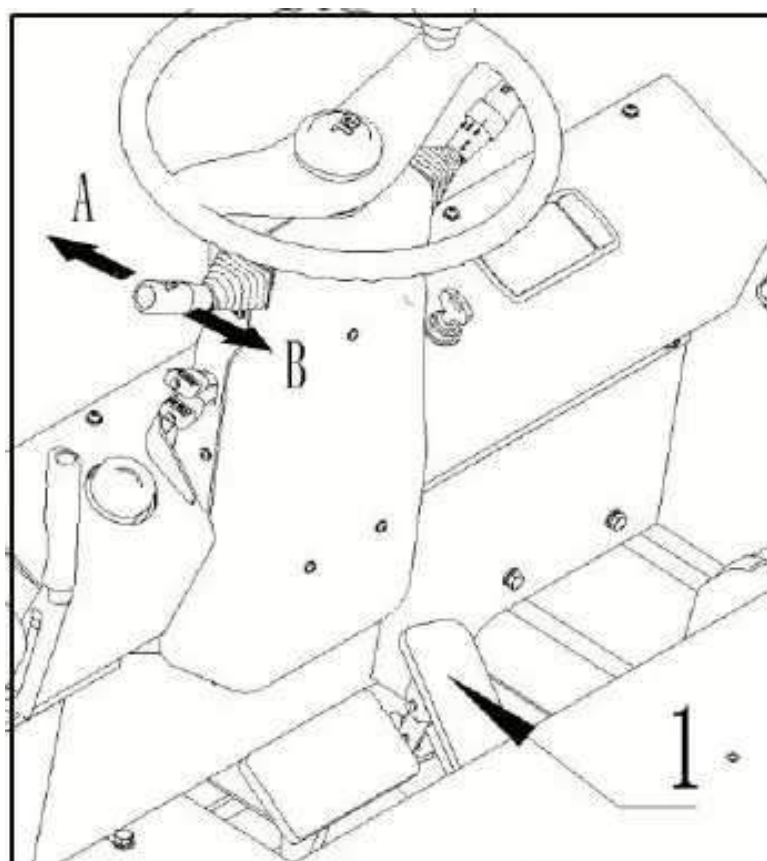

- With the right mark "C" blackened: the lever at "A" position pressing pedal (1) causes the truck to rotate anticlockwise "A"; the lever at "B" position causes the truck to rotate clockwise "B".

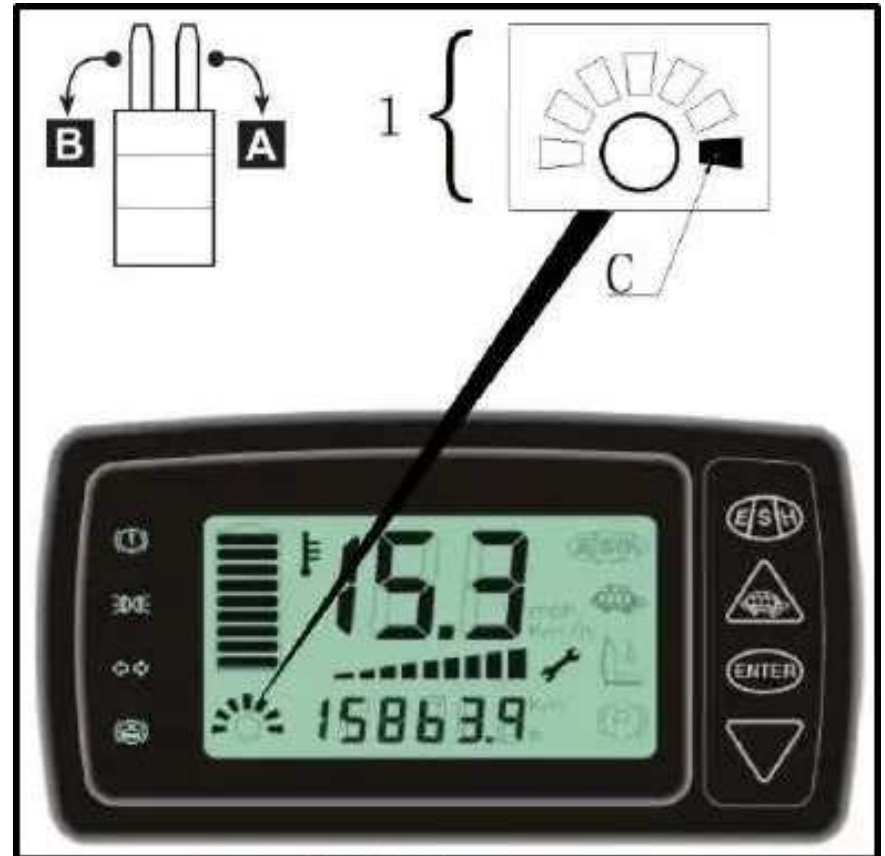

Speed Restrictions

Speed reduction systems are routinely installed on all forklift versions, which cut in in the following cases:

When the forklift is turning;

When the battery is low;



NOTE

The Technical Service Department authorized by the manufacturer can change or introduce other speed restrictions upon request.

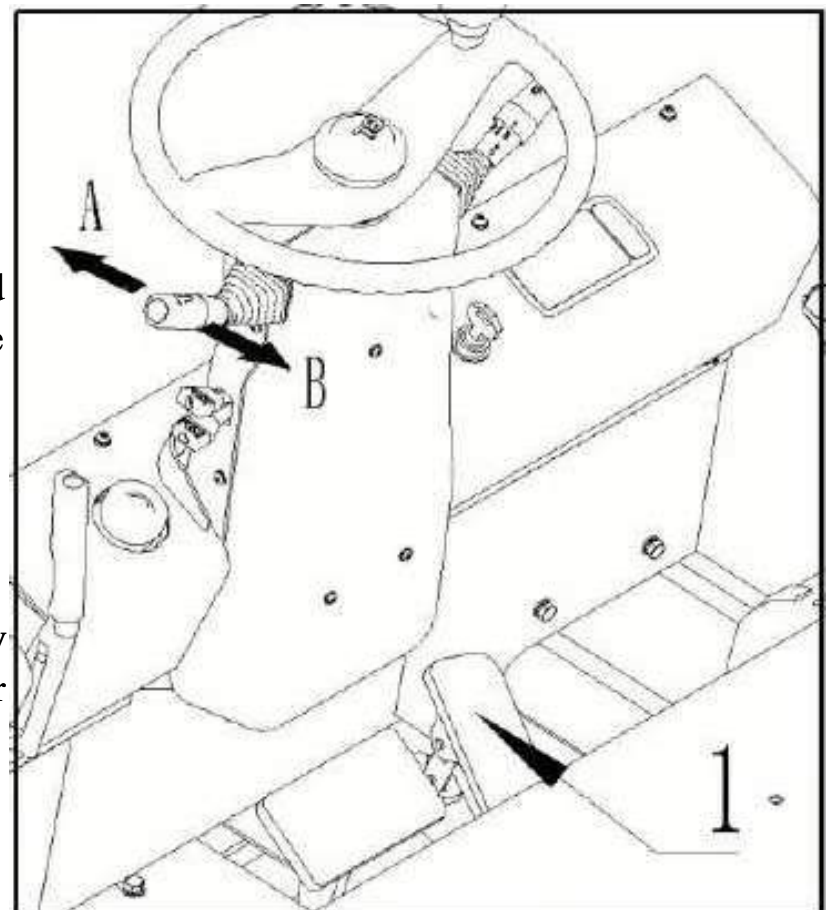

Stopping the forklift in an EMERGENCY

- In case of an emergency, press the emergency stop button (1); the truck will go into neutral if it is in gear, then press the brake pedal to stop.



NOTE

After pressing the emergency stop button, follow the instructions provided in the "EMERGENCY STOP button" paragraph in chapter"3".

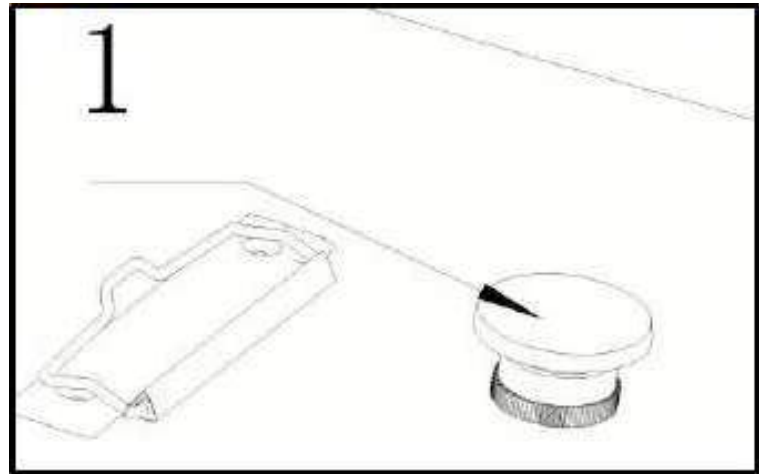

Forklift Use in Cold-Storage Rooms.

A truck specifically equipped for cold-storage rooms must be used when working at temperatures below +5°C.

Trucks equipped for working in cold climates and cold-storage rooms may be used at a minimum temperature of -5°C for continuous service during work shifts in cold-storage rooms and at -32°C for non-continuous service in cold-storage rooms.



CAUTION

The truck must always be parked outside the cold zone/cold-storage room.



CAUTION

If the truck has been working in environments at temperatures below -5°C and it is taken outside the cold-storage room, let it stand either for a sufficiently long time to allow evaporation of any condensation (at least 30 minutes) or a sufficiently short time to prevent the formation of any condensation (less than 10 minutes).

Avoid the formation of ice on the forklift.



CAUTION

NEVER drive the truck into the cold-storage room when condensation has formed on it

Load Placement

Adjustment of the fork distance

- Raise the locking lever (1) or raise and rotate the knob (2) by 180° depending on the type of lock, (1) or (2), installed on the fork arms.
- Move the fork arms (3) in relation to the dimensions of the load to be lifted.
- Be careful to maintain an equal distance of the two fork arms from the centre line of the fork carriage.
- Check that the locking occurs inside one of the notches provided on the fork carriage.

DANGER

For greater load stability, the distance between the two fork arms must be as large as possible while remaining consistent with the load's lifting points so that the load's centre of gravity is at the centre of the fork arms.

DANGER

For greater load stability, the position of the fork arms must be as symmetric as possible with respect to the centre of the fork carriage.

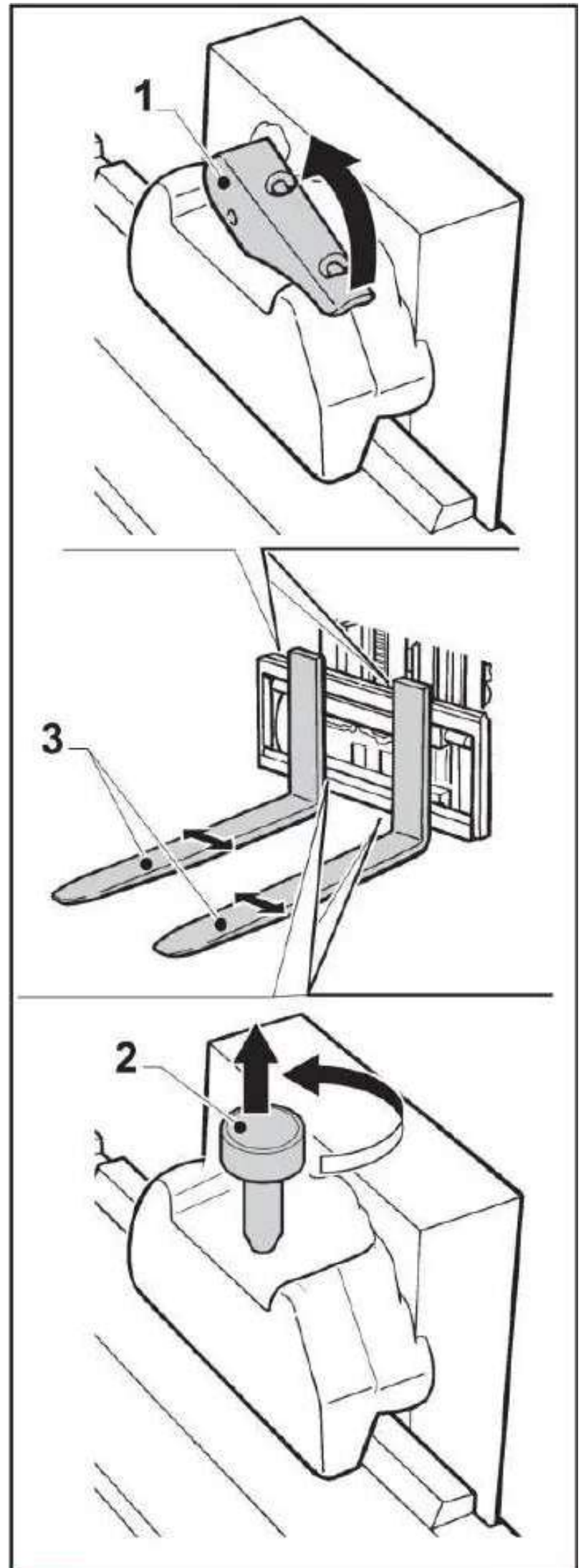

Taking up loads



DANGER

Before removing the load, make sure that its dimensions and weight fall within the truck specifications, as indicated in the "TECHNICAL DATA" chapter and on the capacity label.



DANGER

The loads must be arranged so that they cannot slip or overturn and fall to the ground.



DANGER

DO NOT stand or walk under the raised load. Make sure that nobody stands under the raised load and in the forklift's area of operation..



DANGER

Never leave the forklift with the forks raised whether loaded or not.



NOTE

Further information on the general rules of truck use and taking up and depositing loads is provided in the "Rules for the use of industrial vehicles" manual attached to this manual.

- Approach the load with caution and as carefully as possible.
- Position the lift vertically.
- Raise the fork to the height required to remove the load.
- Approach the load slowly with the truck.
- Insert the fork arms up to the shoulder if possible.
- Slightly lift the load from the carrying surface.
- Tilt the lift BACKWARD.
- Back up the truck the distance necessary to freely perform the manoeuvres.
- Lower the forks with the load to the minimum distance from the ground to be able to travel.

Deposit the load.

- Approach the load deposit area.
- Lift the fork to the necessary height.
- Position the lift vertically so that the load is horizontal.
- Move forward to the deposit position.
- Slowly lower the fork arms until depositing the load in the desired area, and then free the fork arms from the load.
- Back up with the forklift.



DANGER

Never leave the truck with the load raised.



NOTE

Further information on the general rules of truck use is provided in the "Rules for the use of industrial vehicles" manual attached to this manual.

Towing trailers

The forklift is not qualified to tow trailers.

Forklift towing

CAUTION

During the towing operation, the operator must be on board the truck in order to perform the steering and braking operations.



NOTE

Use non-metallic cables for towing.

Version with reversing on the steering wheel

- Before towing models with reversing lever on the steering wheel, check that this lever (1) is in the central position.

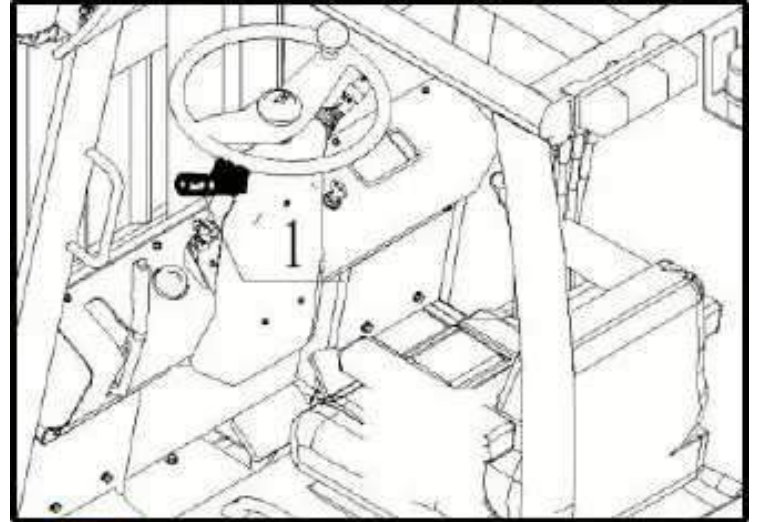

Battery recharging

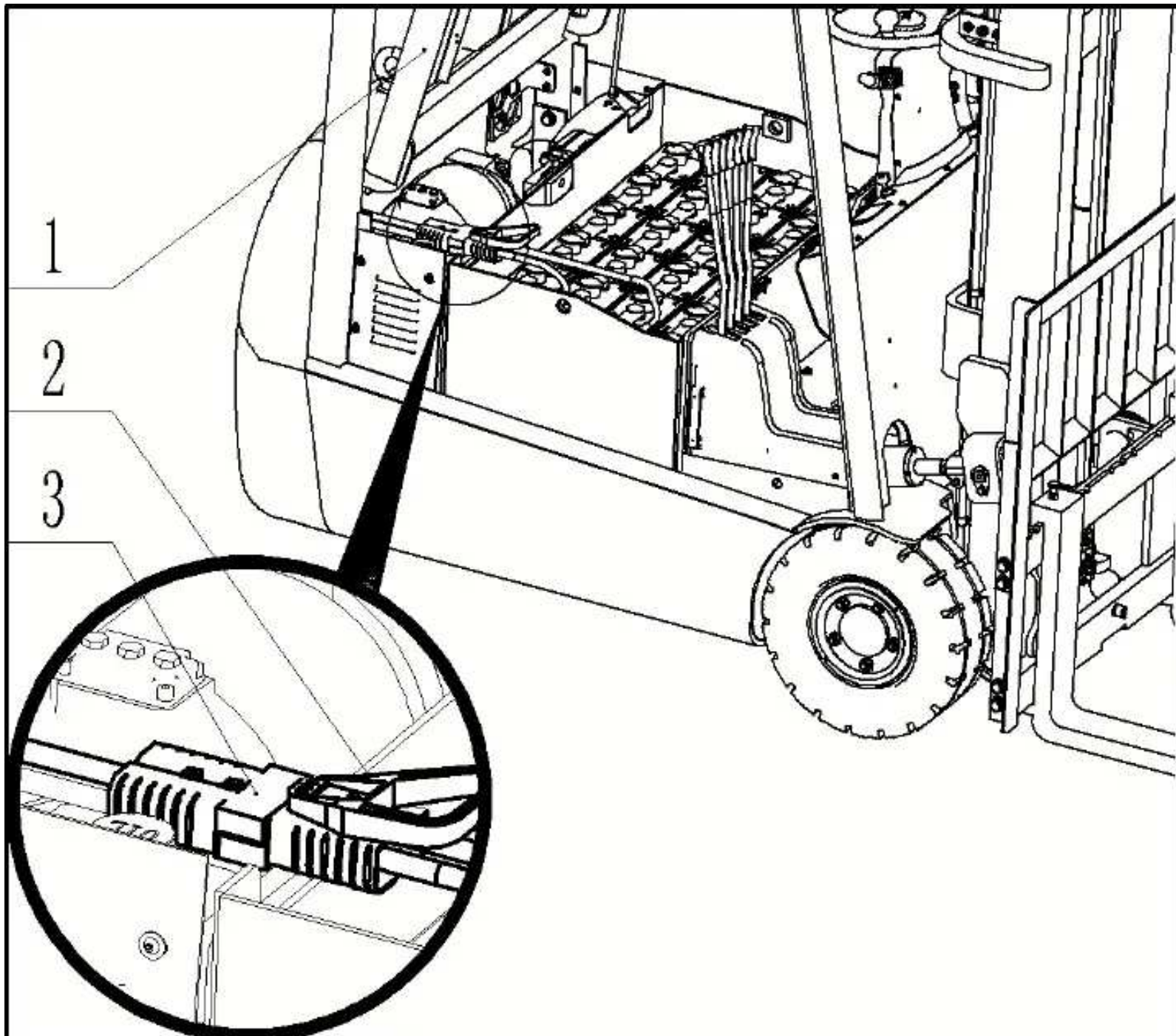

CAUTION

Charge the battery with the forklift turned off and the ignition key removed.



DANGER

The battery must be charged in rooms that comply with the specific regulations on the subject. Refer to the manuals of the battery and battery charger used for information on the charging procedures, and check the voltage supplied. As far as the safety precautions are concerned, follow the instructions given in the battery manual and those included in "Safety regulations" of this manual.

- Park the truck, following the instructions in the paragraph "Leaving the truck".
- Raise the battery compartment hood (1).

- Disconnect the battery outlet (2) from the plug (3).
- If the battery is not already provided with a centralized top-up point, remove the caps of the individual cells; otherwise remove the single cap of the centralized top-up point.
- Connect the outlet (2) to the battery charger to begin charging.
- Turn on the external battery charger.
- When finished charging, repeat the operations in the reverse order to restore the truck to normal working conditions, being careful to check that there is no residual play between the power outlet of the battery and the plug of the electronic equipment.

5

Maintenance

General Information

In order to keep the forklift in good condition, it is important to perform the maintenance operations described on the following pages.

DANGER

These maintenance operations must be carried out by qualified technical personnel authorised by the manufacturer to keep the machine in perfect working order and compliant with the technical specifications.



NOTE

Contact an authorised service centre to arrange a forklift maintenance contract suited to your needs.



NOTE

The maintenance operations must be recorded on the special slips in the warranty booklet.

CAUTION

The manufacturer declines all responsibility for maintenance operations carried out by non-authorised personnel.

Operations Preliminary to Maintenance

Do the following before performing maintenance operations:

- Position the forklift on a flat surface and make sure that it cannot move accidentally.
- Lower the fork arms completely.
- Turn off the forklift and remove the keys
- Apply the parking brake.

- Press the emergency pushbutton.

DANGER

Before performing any intervention on the electrical system, disconnect the battery outlet from the relative plug.

Maintenance as required

Cleaning the Forklift

Cleaning depends on the type of use and the workplace. Should the forklift come into contact with highly aggressive elements such as salt

water, fertilizers, chemical products, cement, etc., it should be cleaned as carefully as possible after every work cycle. It is preferable to use compressed air and detergents when the forklift is

cold. Use water-dampened rags to clean the parts of the body.

 CAUTION

Do not clean the forklift with direct jets of water; DO NOT use solvents and gasolines that could damage some parts of the forklift.

Seat and seat belt cleaning

Cleaning of the seat

Clean the seat using a sponge or cloth dampened in water with neutral detergent.

Cleaning of the belt

Clean the belt using a sponge dampened in a solution of water and neutral soap.

 CAUTION

Do not clean the seat with abrasive detergents or corrosive liquids, and do not wash it using pressurized water or steam. When cleaning the padded surfaces, avoid passing humidity through the padding.

Lamp replacement (if applicable)

Before replacing a lamp, check that the respective fuse is intact. Replace the lamp with another one having the same characteristics (see the technical data chapter).

 CAUTION

Do not use chlorine bleach, dyes or domestic detergents.

Rear lights unit lamps

Follow the instructions in the points below in order to change a lamp in the rear lights unit.

- Remove the transparent cover (1) by unscrewing the two screws (2).
- Lightly press and turn the burnt-out lamp to remove it from the bayonet fitting, and then replace it with a new one. The lamp positions are as follows:
- Reversing lights lamp (3)
- Stop lights lamp (4)
- Put the transparent cover (1) back on.



NOTE

The indications refer to the left rear lights unit.

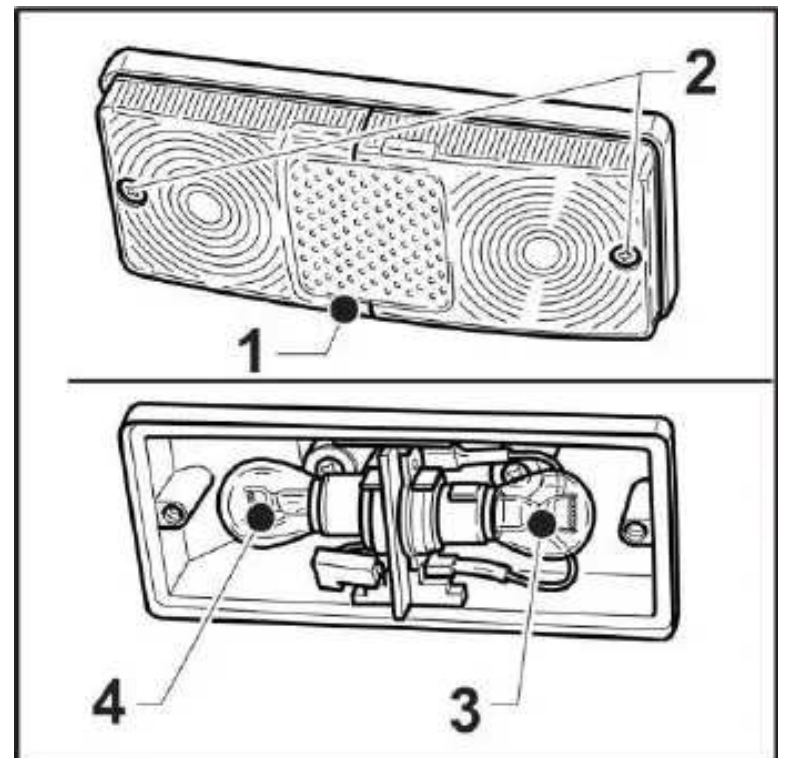

Work light replacement procedure (optional)

- To replace a working lamp bulb, loosen the screws (1) and remove the light cluster (2).
- Release the bulb (3) by releasing the spring pins (4), then disconnect the plug (5) and change the bulb.
- Retting is the reverse of removal.

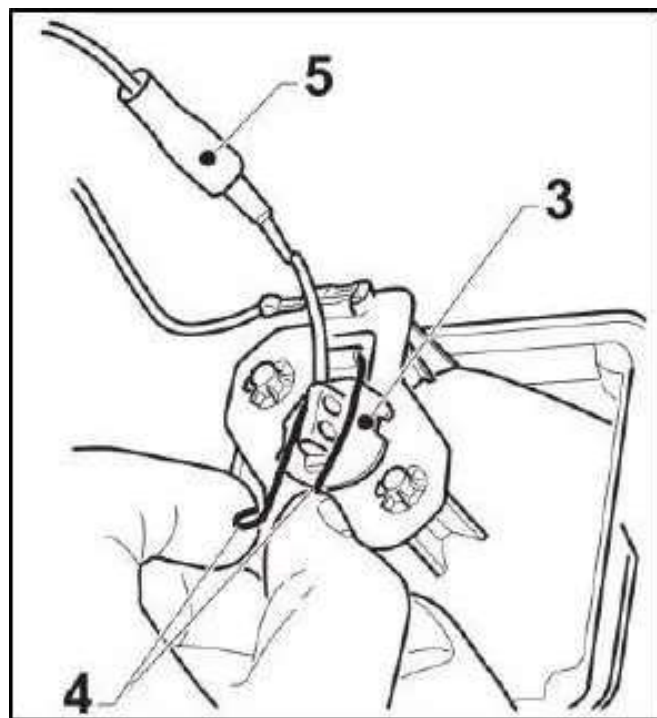
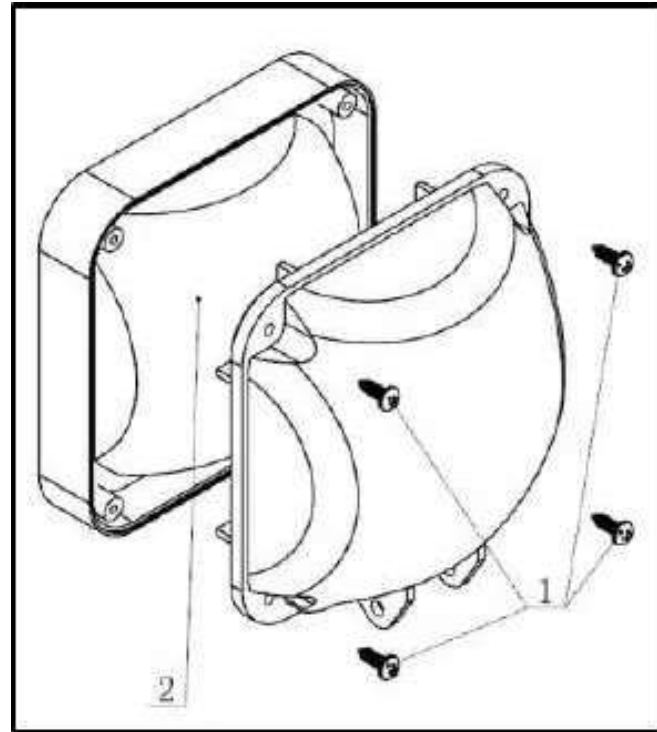

Tyrewear check

SOLID TYRES

The solid tyres should be changed before reaching the maximum wear allowed.

DANGER

If the forklift is used on wet or slippery surfaces, replace the tyres before the thickness of the tread drops below 1.6 mm.

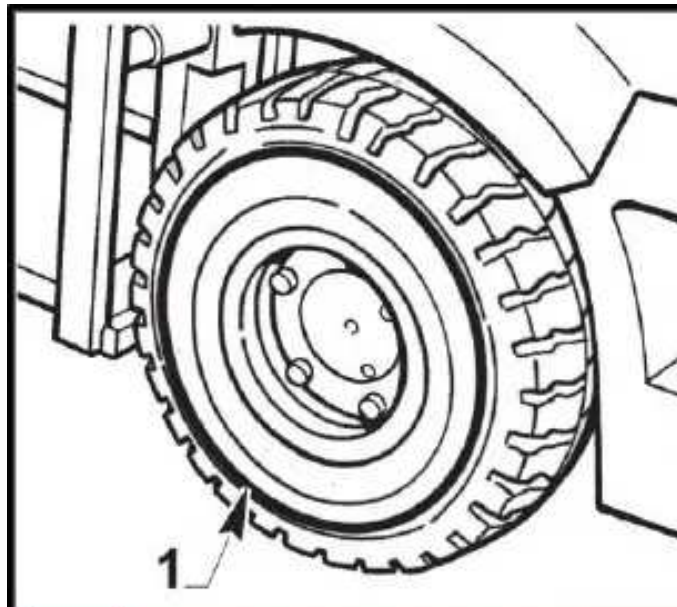

Wheel change

Changing a rear wheel

- Turn the rear wheel (1) so that the fixing screws are accessible.
- Turn off the forklift and perform the operations preliminary to maintenance.
- Partially loosen the wheel locking nuts (2).
- Pass a sling (3) through the tow coupling (4) and hook the other end to a crane with a suitable capacity (for further information, see the chapter "Forklift transport and lifting").
- Lift the rear part of the truck and place suitable supports (5) under the counter weight (6).
- Lower the truck so that it rests on the supports, keeping the sling tensioned.
- Completely unscrew the nuts (2) and pull off the wheel.
- Fit the new wheel
- Tighten the fixing screws, following the sequence indicated in the paragraph regarding the next stages.
- Slightly tighten the screws so that the wheel is well seated against the hub.
- Tighten the screws to 50% of the prescribed torque.
- Raise the truck to free the supports.
- Remove the supports.
- Lower the truck to the ground.
- Tighten the fixing screws.
- Completely tighten the fastening screws (see associated paragraph).
- Repeat the operations described above to change the second wheel.

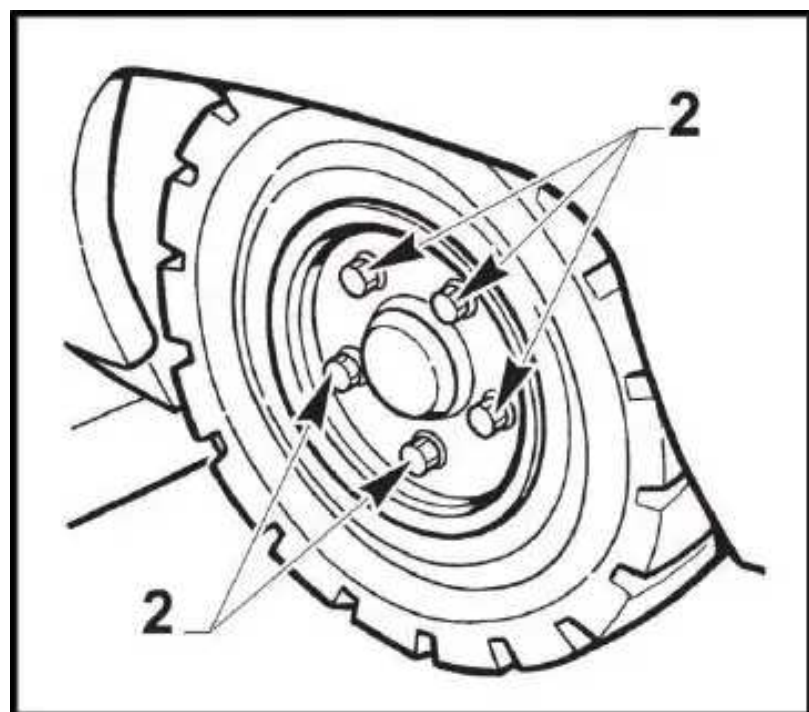
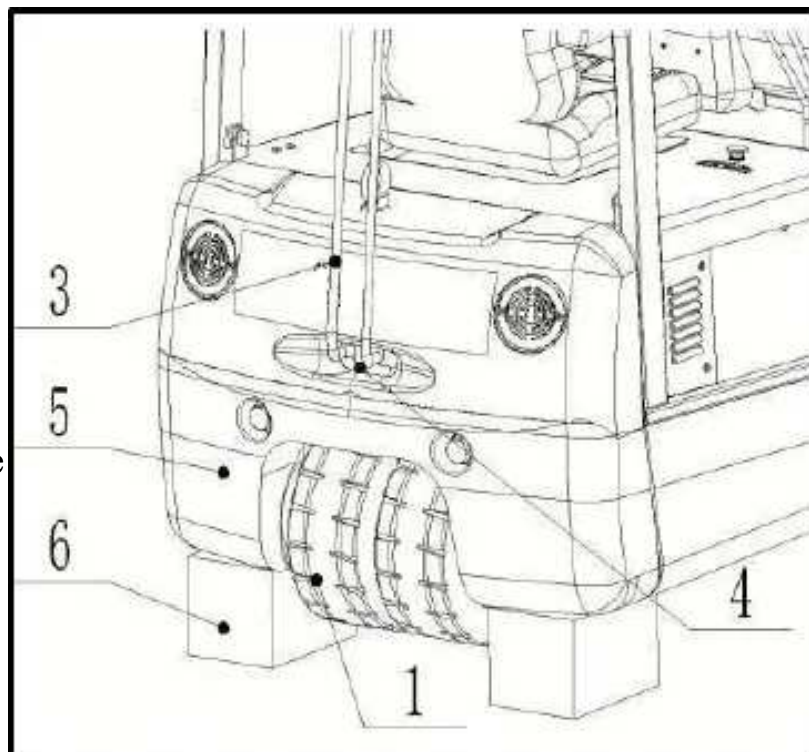

Front wheel change.

- Turn off the forklift and perform the operations preliminary to maintenance.
- Partly slacken the wheel fixing nuts (1).
- Pass a sling (2) over the top cross member (3) of the fixed mast of the lift and hook the other end to a crane with suitable capacity.
- Lift the front part of the truck and place suitable supports near the wheel to be changed.
- Lower the truck so that it rests on the supports, keeping the sling tensioned.
- Completely unscrew the screws (1) and pull off the wheel.
- Fit the new wheel.
- Tighten the fixing screws, following the sequence indicated in the paragraph regarding the next stages.
- Slightly tighten the screws so that the wheel is well seated against the hub.
- Tighten the screws to 50% of the prescribed torque.
- Raise the truck to free the supports.
- Remove the supports.
- Lower the truck to the ground.
- Tighten the fixing screws.
- Completely tighten the fastening screws (see associated paragraph).

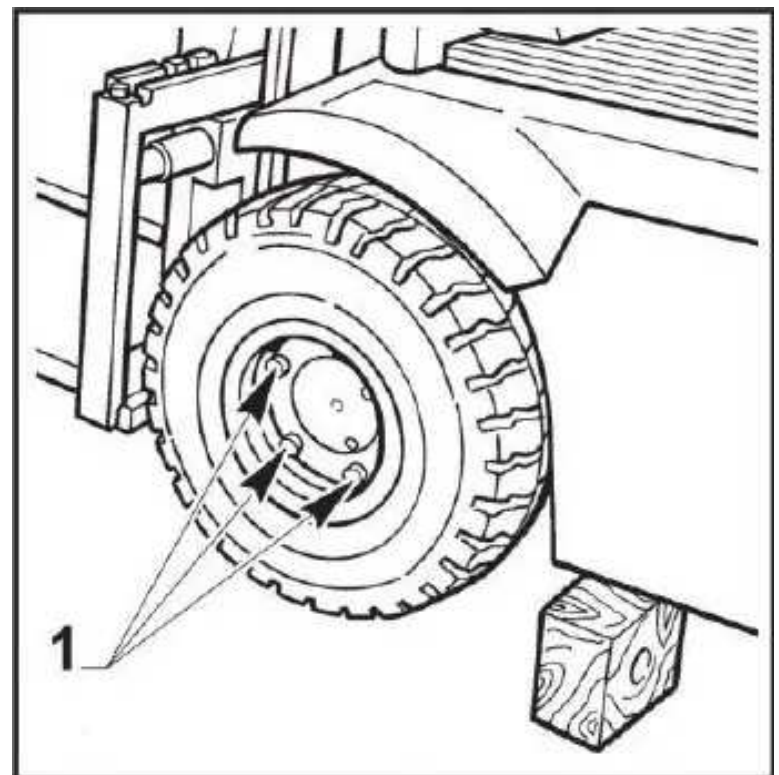
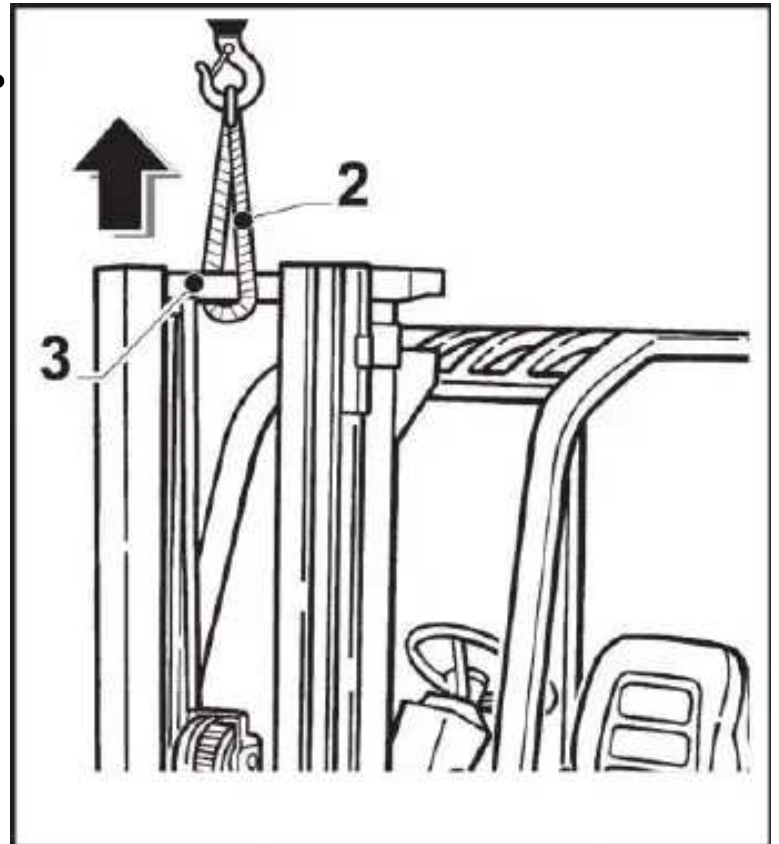

Changing the battery

Turn off the forklift and perform the operations

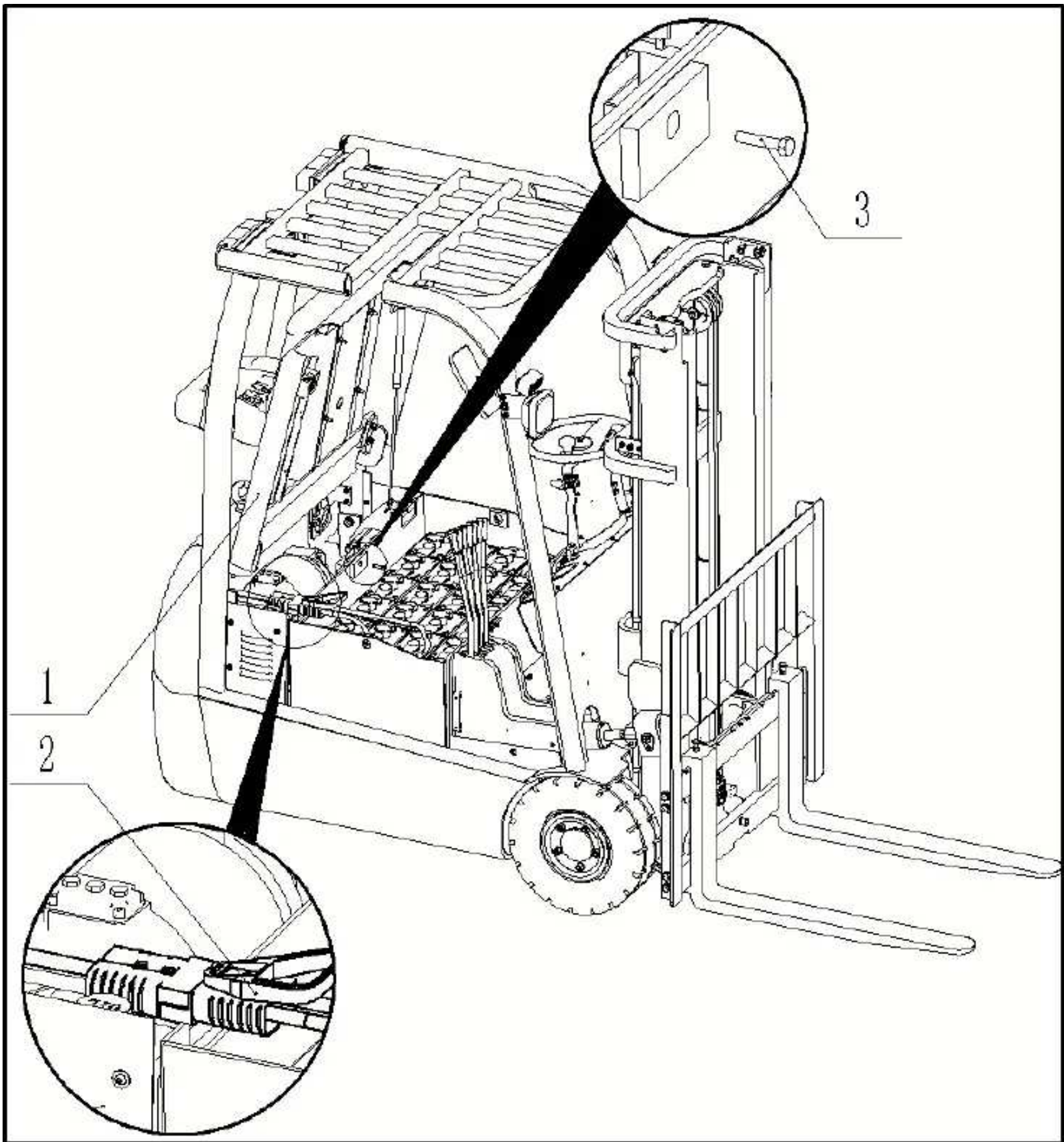

Preliminary to maintenance

- Raise the battery cover (1) as indicated in the relative chapter.
- Disconnect the plug (2) and position it above the battery.
- Completely unscrew the screws (3)

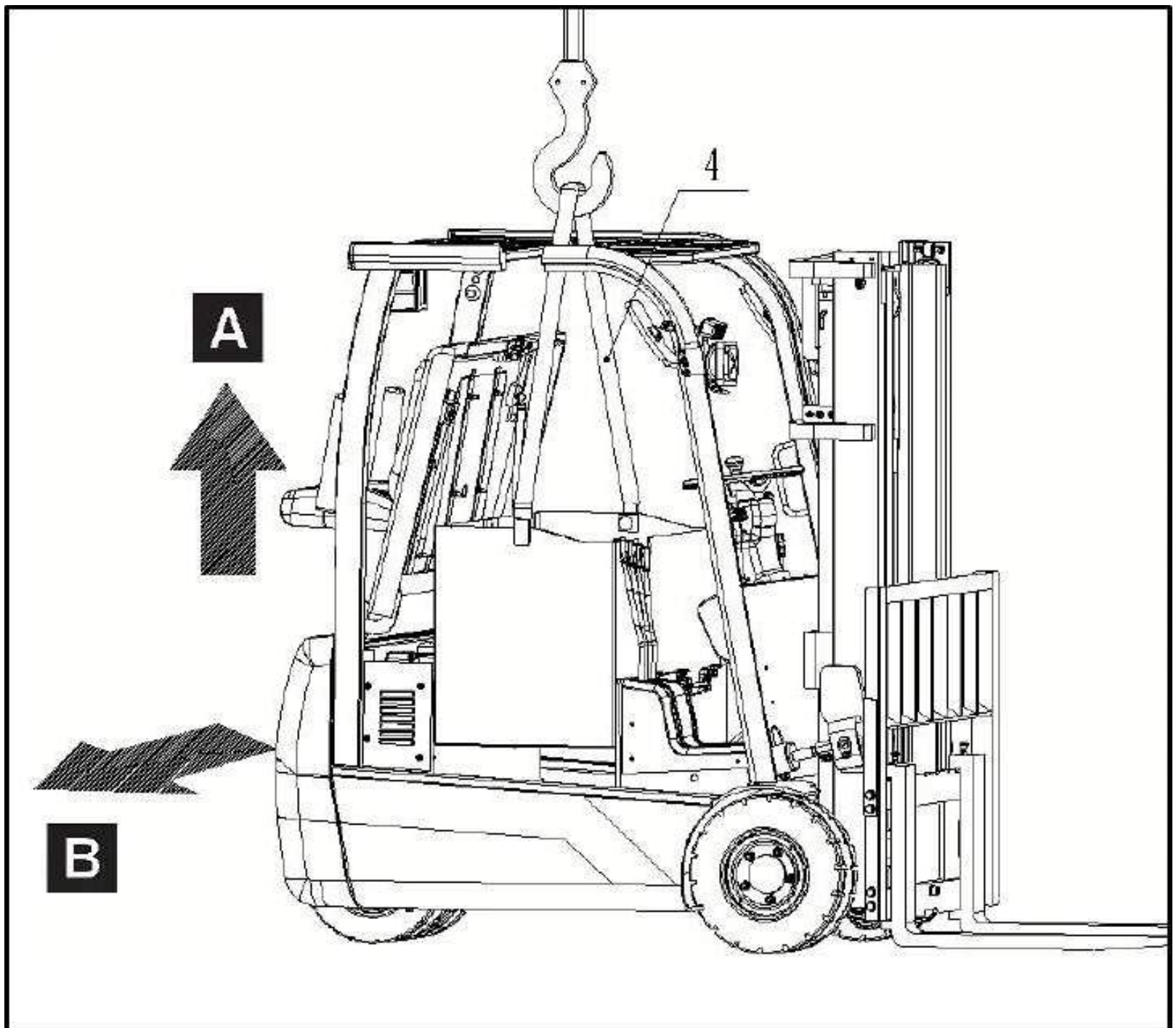

- Hook the battery at the two points with a sling (4), chain or suitable lifting beam by inserting the hook of a crane in the special opening on the overhead guard.
- Lift the battery in direction "A" to the height necessary to remove it. Use a hoist with a suitable lifting capacity for the weight of the battery as indicated on the plate.
- Take the battery out sideways to the right in direction "B".

Replace the battery and remount it by following the disassembly steps in the reverse order.

CAUTION

Use only NON METALLIC slings or METALLIC chains only if covered with a suitable thickness of insulating rubber.
Maintenance as required

Changing a fuse

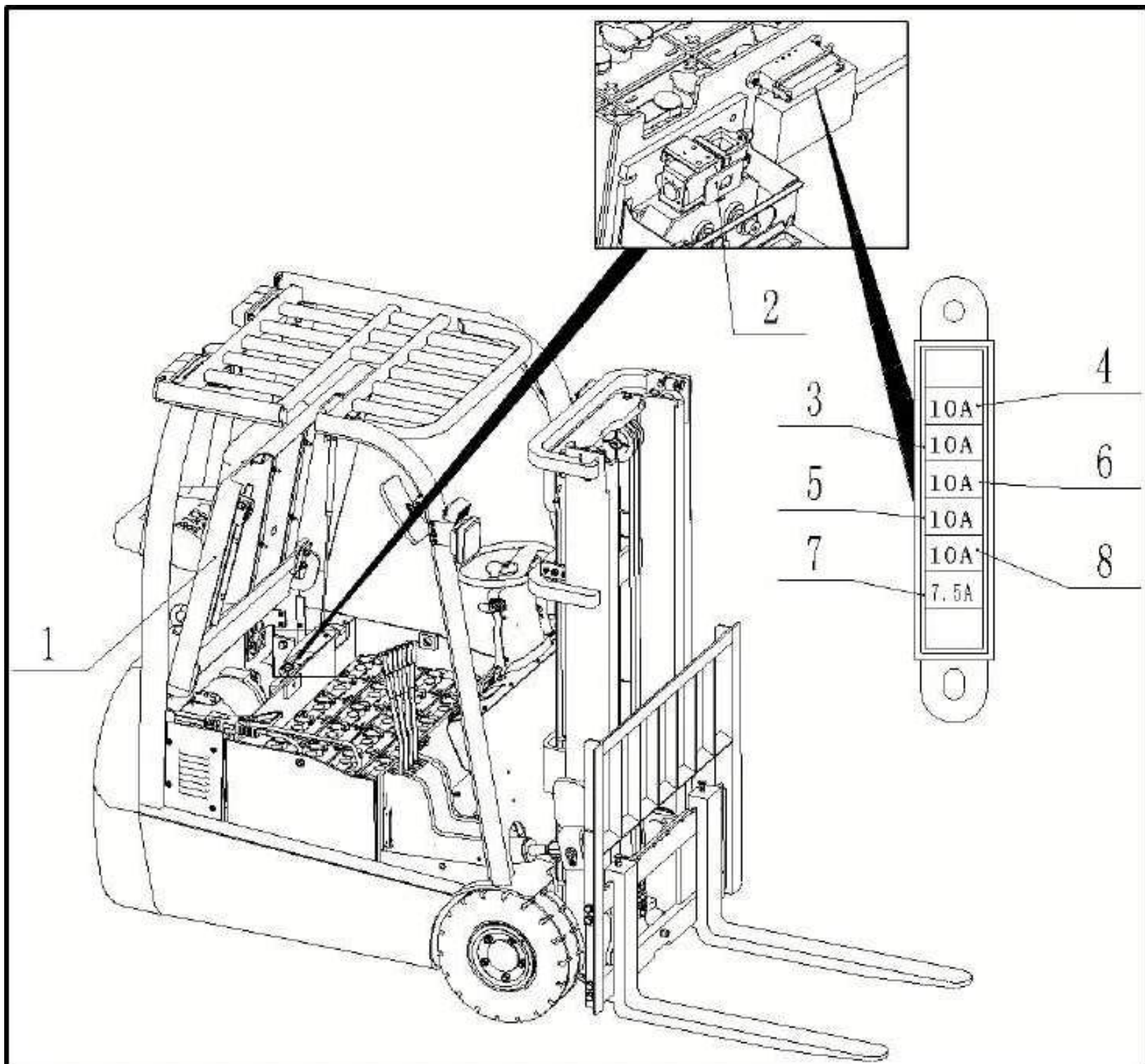

Turn off the forklift and perform the operations preliminary to maintenance.



CAUTION

Before changing a fuse, eliminate the cause that led to its blowing. The blown-out fuse must be replaced with a fuse of the same amperage only. Do not tamper with the forklift's electrical system.

- Raise the battery cover (1) as indicated in the relative paragraph.
 - The power fuse (2) is positioned on the electronic units, while the service fuses (3, 4, 5, 6, 7, and 8) are positioned in the relative fuse box.
 - Power Fuses (2)
 - Loosen the screws and replace the fuse, then retighten the screws.
 - Service and Auxiliary Fuses (3, 4, 5, 6, 7, 8)
 - Change the blown fuse in the fuse box.
 - Fuse Values
- "2" = Traction and Pump power fuse 700A
 - "3" = DC-DC start signal fuse 10A
 - "4" = Blade fuse for starting switch 10A
 - "5" = Blade fuse for lights converter 10A
 - "6" = Reserve fuse
 - "7" = Reversing lights fuse 10A
 - "8" = Blade fuse for horn 10A

Scheduled Maintenance

General

In order to keep the forklift safe and in good condition, have it serviced according to the scheduled maintenance operations indicated in

the following "synoptic table of maintenance intervals".



CAUTION

When the forklift is used in dusty environments, at below zero temperatures and for especially heavy uses, it is necessary to reduce the interval between the various scheduled maintenance operations.

Synoptic Table of Maintenance Operations

Operation	hours	work
Check wheel nut tightening	100	check
Parking brake check	200	check
Chain tension check and adjustment	1000	check
Check hydraulic tank oil level	1000	cleaning
Cleaning of the electronic panel	1000	cleaning
Lubricating the steering axle	1000	Lubricating
Fork carriage guide lubrication	1000	Lubricating
Service brake check	200	check
Trunnions greasing	1000	Lubricating
Reduction gear oil level check	2400	change
Rolling tracks greasing	1000	check
Grease rear wheel bearings	1000	check
Seat belt blocking system check	1000	check
Lubricate lift chain	1000	Lubricating
Chain check and maintenance	• ⁽¹⁾	
Change gearbox oil	• ⁽³⁾	
Check and adjust lift clearances	1000	check
Change hydraulic oil filter cartridge	• ⁽²⁾	
Protective roof tightening screws check	1000	check
Check fork wear	• ⁽¹⁾	
Check brake oil level	daily	check
Change hydraulic system oil	2400	change
Axial maintenance	2400	change
Change brake oil	2400	change

(1) = To be carried out absolutely every 3 months or according to current legislation.

(2) = Every 1000 hours or at least every 12 months.

(3) = First change after 100 hours, then every 1000 hours or every year.



ENVIRONMENT NOTE

Proceed as follows at each lubrication operation:

- Follow the safety precautions for the lubricant;

- Before lubricating, carefully clean the component to be lubricated;
- Use suitable binders if the lubricating product should spill;
- Keep the product in a suitable and compliant place, as per the instructions supplied with the product;
- Dispose of the lubricating product in compliance with the current laws.

EVERY 1000 HOURS

Check wheel nut tightness (every 10 hours during run-in)

- Check the wheel nut tightening according to the intervals indicated in the preceding maintenance table and when a wheel is replaced.
- Follow the instructions provided in the relative chapter when replacing a wheel.
- The figure to the side indicates the tightening order of the wheel locking nuts.

The tightening torque values for the wheel nuts are indicated below:

- Front wheels = 140 Nm
- Rear wheels = 220 Nm



NOTE

The tightening torque indicated is for clean, degreased screws without the application of lubricants.

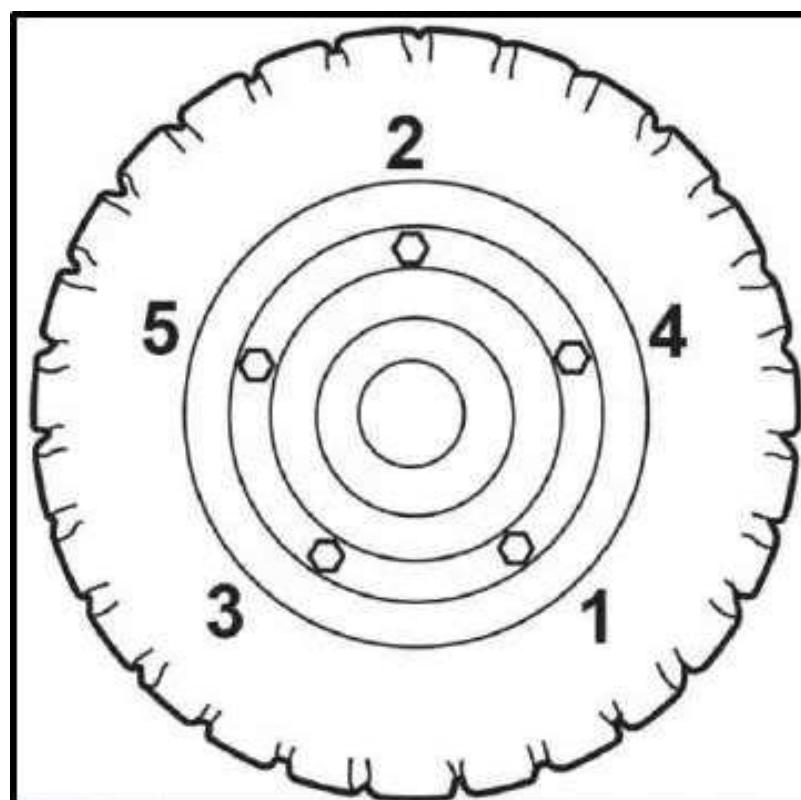

Chain tension check and adjustment

Check that the chains are equally tensioned and, if necessary, adjust them as described below:

- Turn off the forklift and perform the operations preliminary to maintenance.
- Unscrew the screw (2)
- Adjust the tension of the chain (3) by operating on the nut (1).
- When the adjustment is finished, reassemble the screw retainer (2).

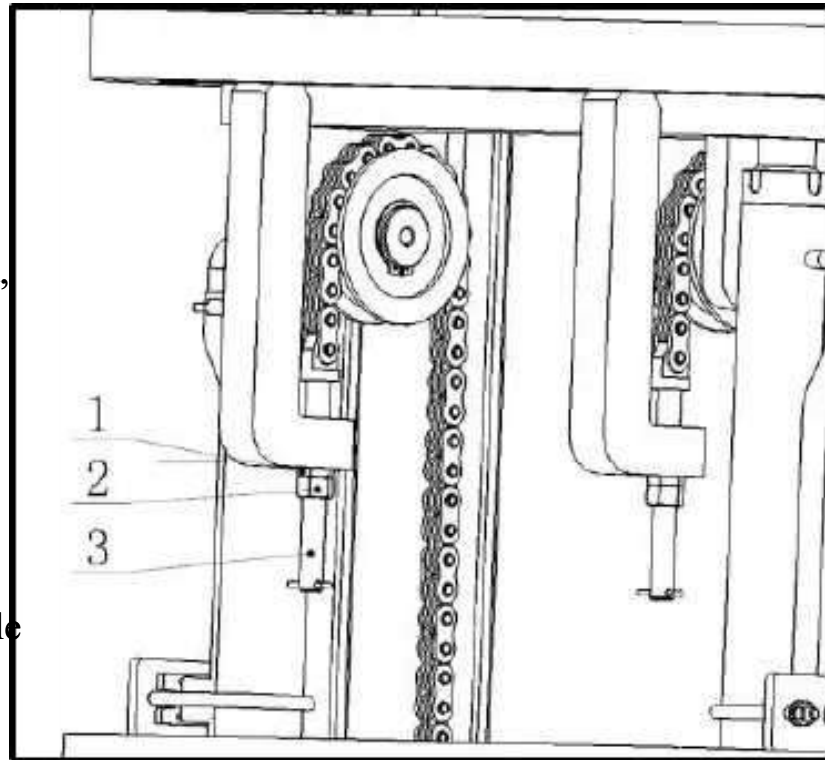

Check hydraulic tank oil level

Turn off the forklift and perform the operations preliminary to maintenance.

- open the battery cover (1).
- open the oil cover(2) to check the oil level
- Top up or take out, if necessary.

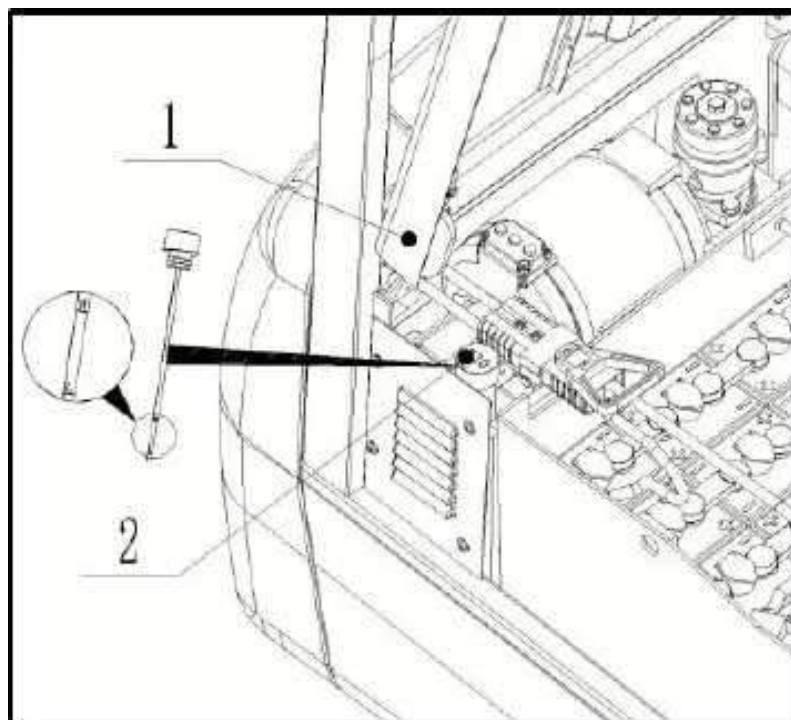

CAUTION

The hydraulic oil level must be checked by positioning the truck on a flat surface with the fork arms at the maximum elevation and the lift tilted forward.

NOTE

Use the type of oil indicated in the supply table provided in this chapter.
When the oil check and top-up operation is completed, reassemble the parts proceeding in the reverse order

Cleaning of the electronic panel

Turn off the forklift and perform the operations preliminary to maintenance.

To access the electronics panel, raise the battery cover (1) as indicated in the relative paragraph.

Clean the electronics panel using a jet of low-pressure dry air, thoroughly cleaning the contacts of the module components (2).

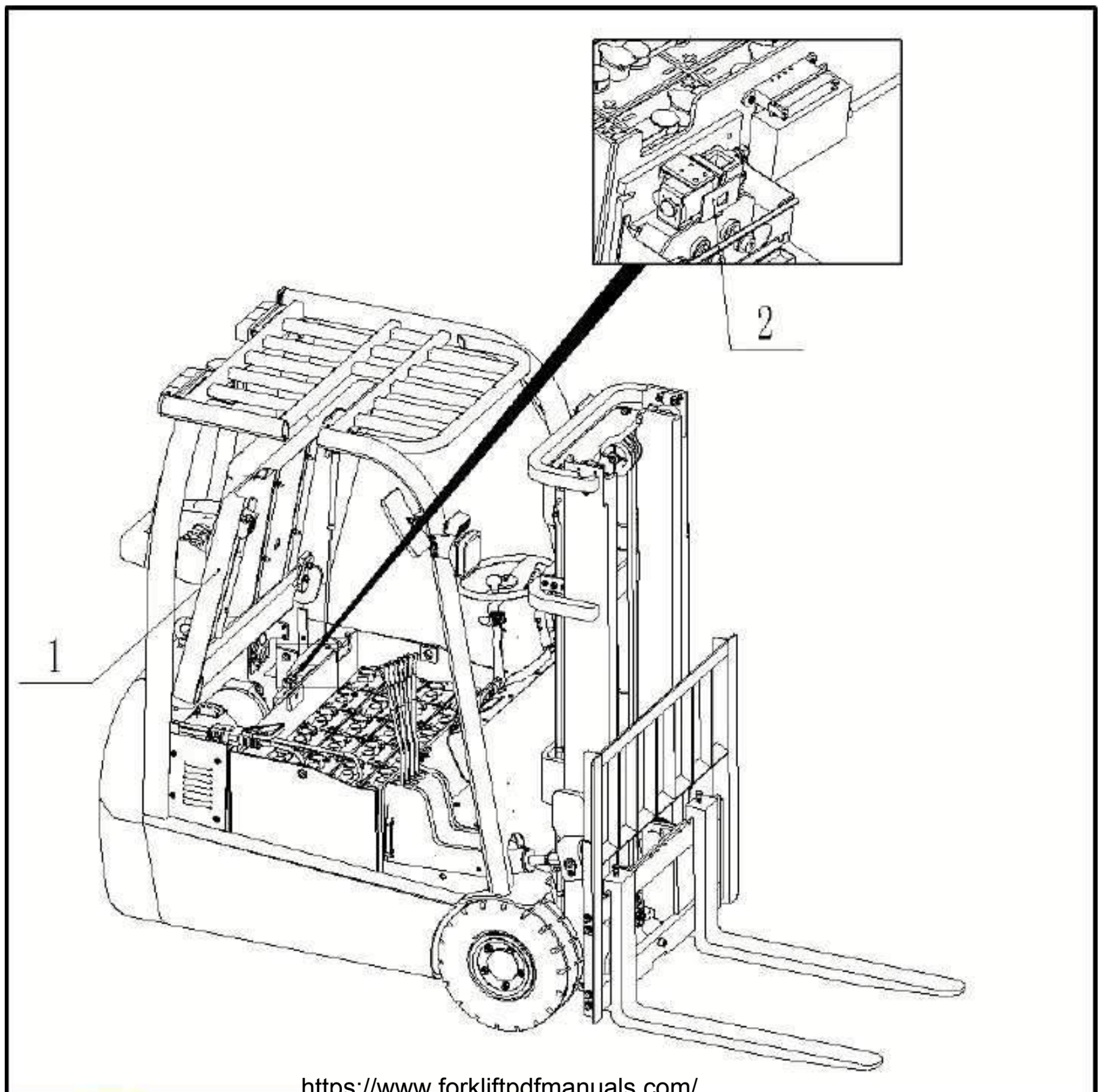

Fork carriage guide greasing

Turn off the forklift and perform the operations preliminary to maintenance.

i NOTE

Clean the carriage guides before greasing.
Grease the guides (1) using a brush.

i NOTE

For the type of lubricant to use, follow the indications provided in the "Supply" table at the end of this chapter.

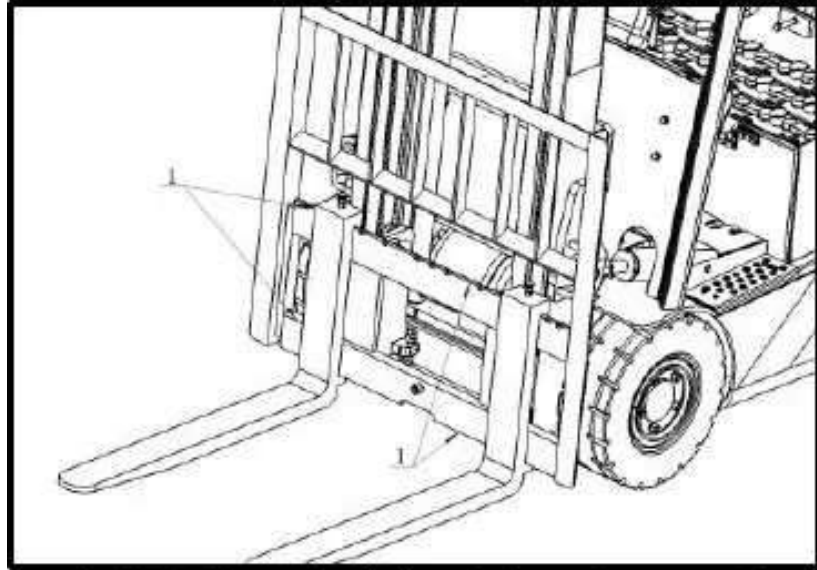

Trunnions greasing

Turn off the forklift and perform the operations preliminary to maintenance.

i NOTE

Before greasing, clean the heads of the grease nipples.

Grease the trunnions using the grease nipples (1) located on both sides of the mast.

i NOTE

For the type of lubricant to use, follow the indications provided in the "Supply" table at the end of this chapter.

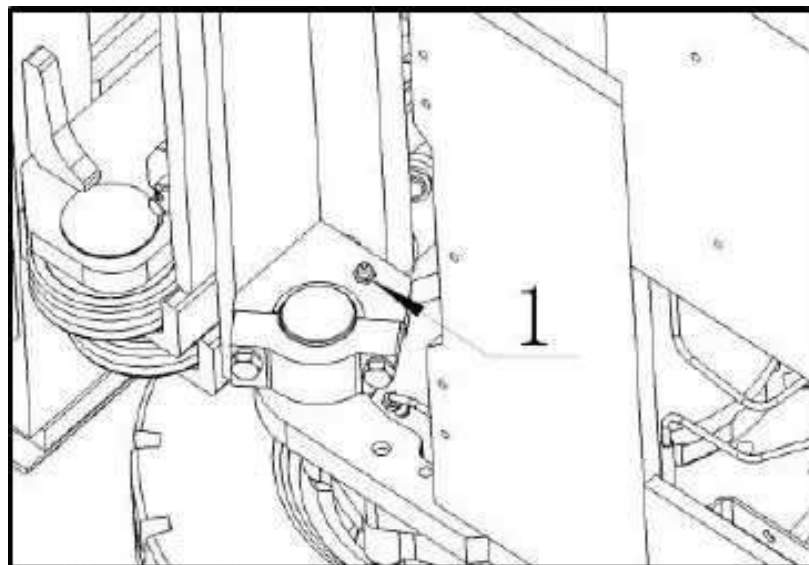

Lubricate lift chain

Turn off the forklift and perform the operations preliminary to maintenance.

 NOTE

If the truck is used in an environment with a particularly aggressive atmosphere, it is advisable to perform lubrication with water-repellent adhesive grease in addition to the normal lubrication.

Lubricate using a spray for chains.

 NOTE

For the type of lubricant to use, follow the indications provided in the "Supply" table at the end of this chapter.

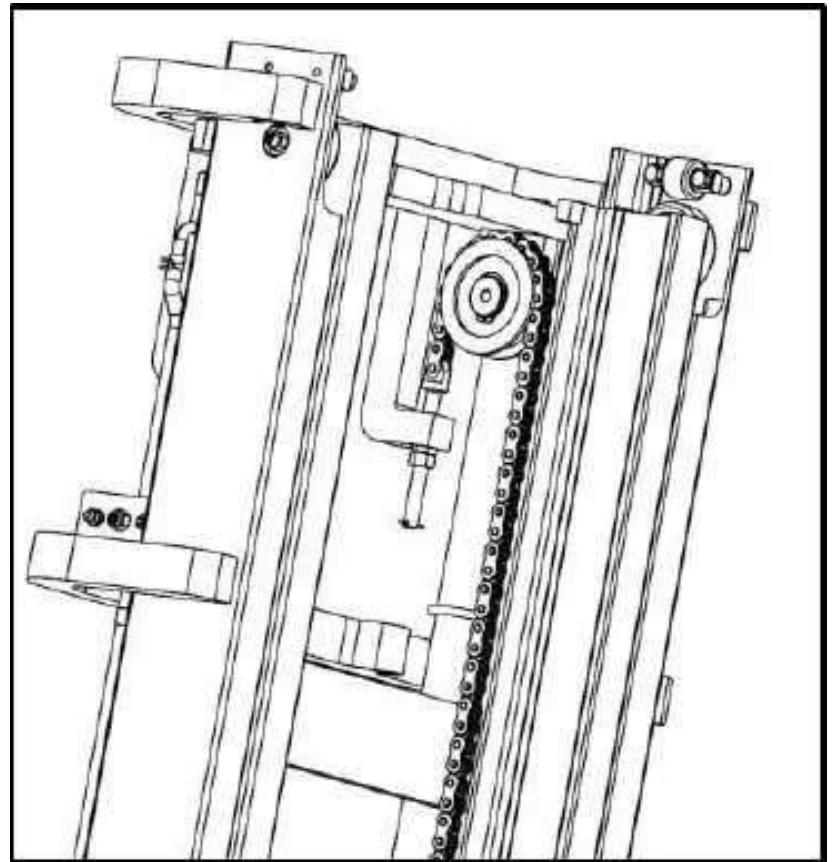

Rolling tracks greasing

Turn off the forklift and perform the operations preliminary to maintenance.

 NOTE

If the truck is used in an environment with a particularly aggressive atmosphere, it is advisable to perform lubrication with water-repellent adhesive grease in addition to the normal lubrication.

Use a brush to lubricate the rolling tracks on the various parts of the lift mast (1) using the type of grease indicated in the "Supply" table at the end of this chapter.

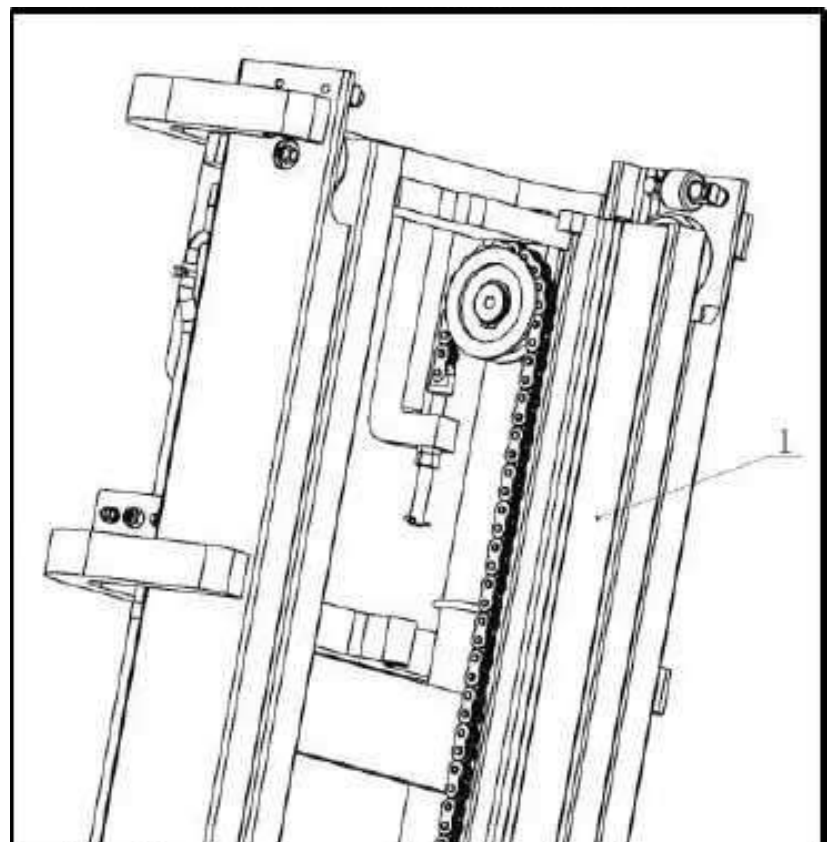

Change the hydraulic oil filter cartridge

- Turn off the forklift and perform the operations preliminary to maintenance.
- Access the filter as indicated in the
- paragraph "Hydraulic tank oil level check". Unscrew the screw (1) and remove the counterweight (2)
- unlock the cover (3) and remove the side plate (5) by unscrew the screw (4).
- Unscrew the screw (6) and remove the fan support(7)
- Unscrew the screw (8) and screw (10),remove the joint (9) and oil pipe(11)
- the filter (12) is on the pipe (11), replace the filter.

 NOTE

Check the oil level using the dipstick and, if necessary, add oil to restore the normal level. Ret by reversing the removal sequence.

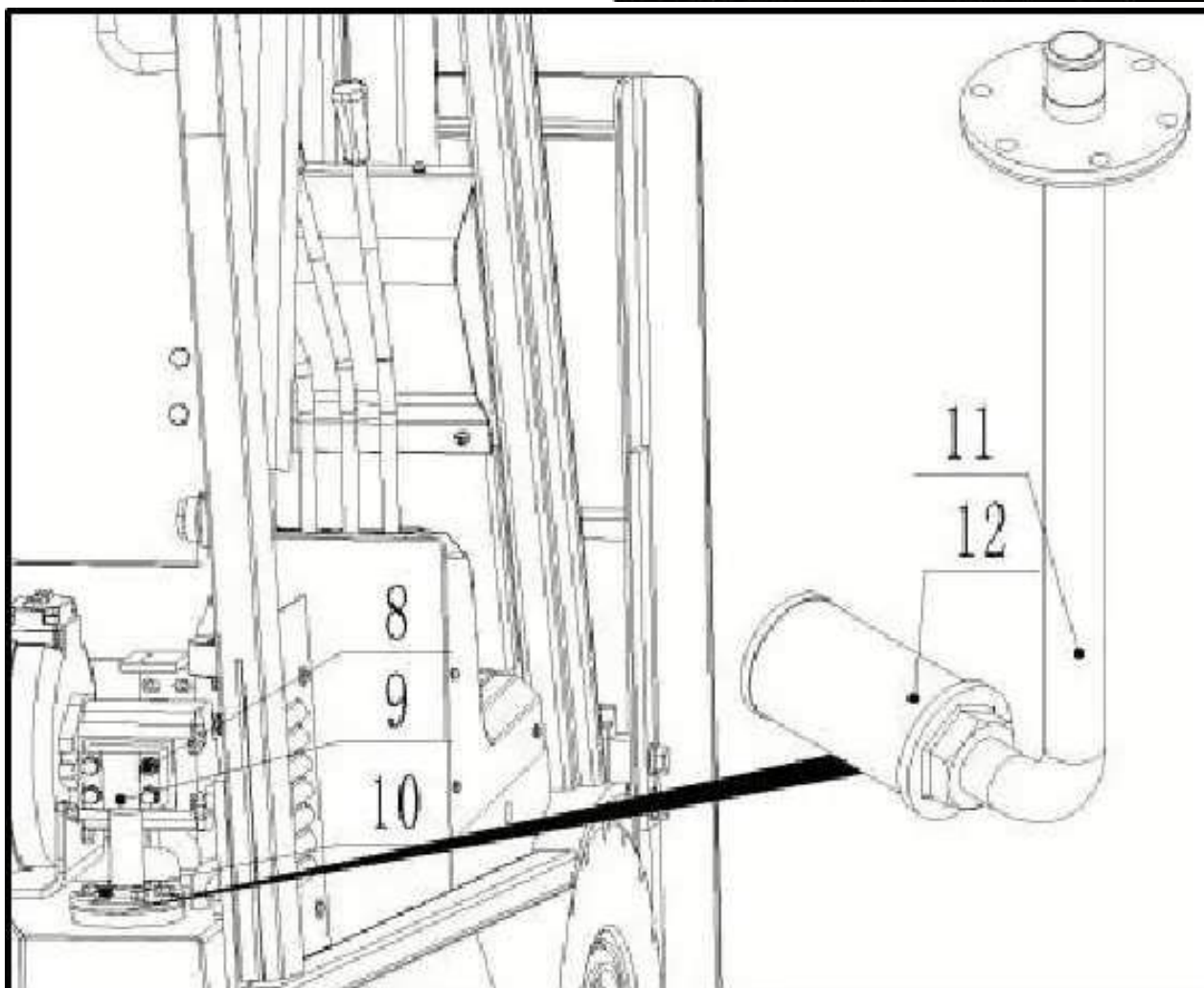
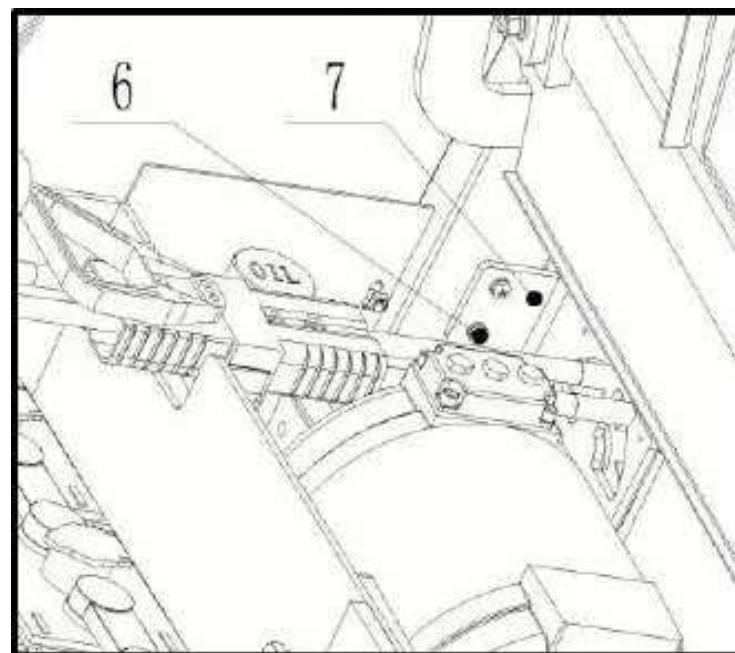
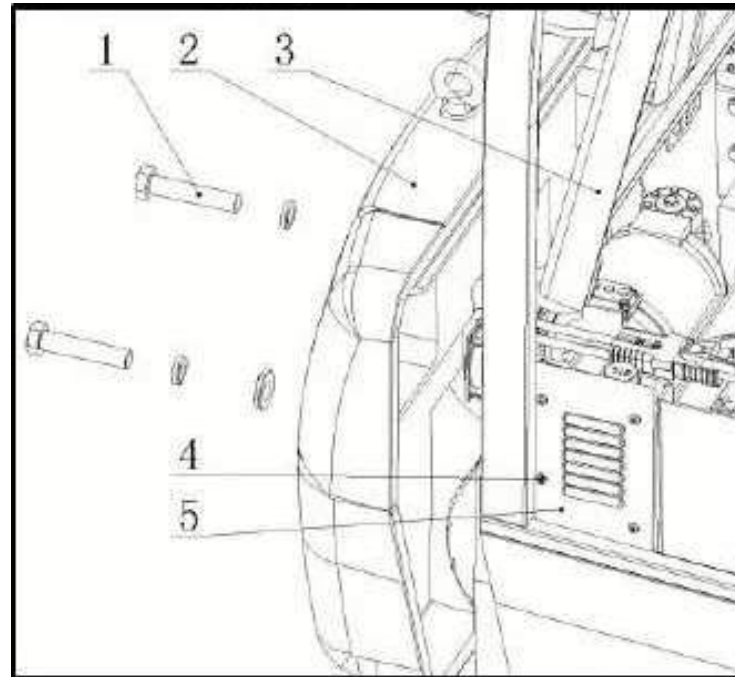

Chain check and maintenance

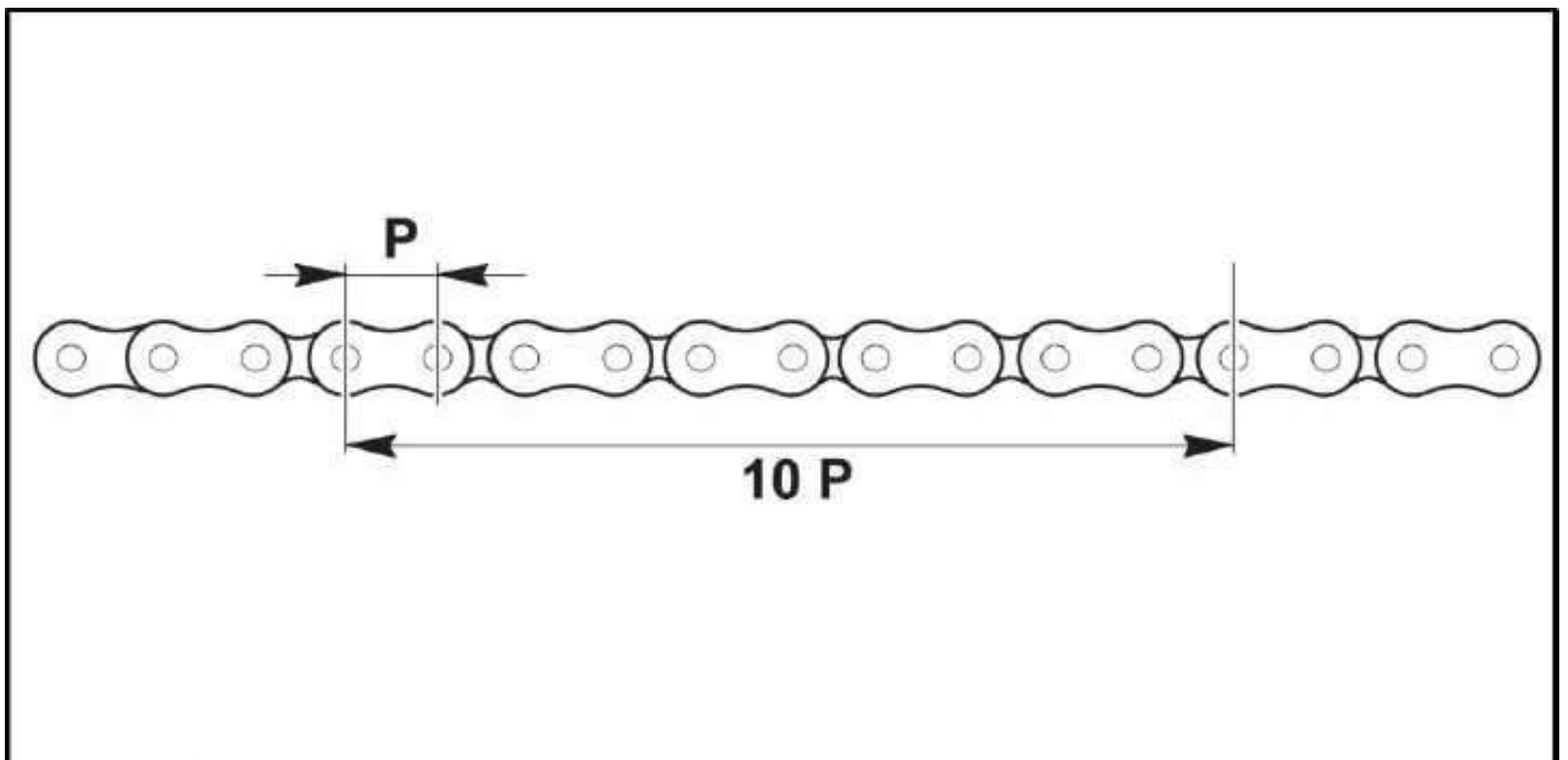

- Turn off the forklift and perform the operations preliminary to maintenance.

DANGER

To be carried out absolutely every 3 months or according to current legislation.

- After having washed the chain and before lubricating it, carefully check the condition of each chain link in detail. In particular, check for cracking on the thin plates.
- Also measure the elongation on several sections of 10 chain pitches. If the maximum elongation measured exceeds 2% of the nominal length of 10 pitches, the chain must be replaced. It is important to note, however, that the elongation is not an index of yielding due to fatigue but rather a wear status of the clearances between links. It may occur that the chain must be replaced because it is close to yielding due to fatigue, without however being able to measure an appreciable elongation due to wear. This occurs mainly for the forklifts that frequently travel on hilly stretches.
- Carefully check also the chain tensioning attachments: both the chain attachment sheaves and the threaded bolt.
- Replace them, together with the respective nuts and washers, when the chains are replaced.
- Check the locking split pin and replace it if necessary.

Seat belt conditions and performance check



DANGER

For technical safety reasons, the conditions and performance of the restraint devices must be checked daily.



CAUTION

Perform careful visual and functional inspections of the winder locking device, the belt fastening device, the anchoring of the belt to the seat and the anchoring of the seat to the hood.

Check the belt condition: Completely unwind the belt (1) from the winder (2) and make sure that it is not damaged.



CAUTION

Belts that are cut frayed in any way damaged or mounted on vehicles that have been in an accident must be replaced. Always replace the restraint system as a whole: belt, buckle, winder, fastening device.

- Check correct fastening device (3) operation: Insert the buckle of the belt (1) into the fastener (3) until a click is heard. Make sure that the locking mechanism of the belt buckle (1) in the fastener (3) works correctly.
- Check of correct belt blocking mechanism operation:
- Park the forklift on a level surface.
- Yank the belt. The blocking mechanism must block the unwinding of the belt (1).
- Perform a visual and functional inspection of the fastening of the belt to the seat
- Perform a visual and functional inspection of the fastening of the seat to the battery cover.

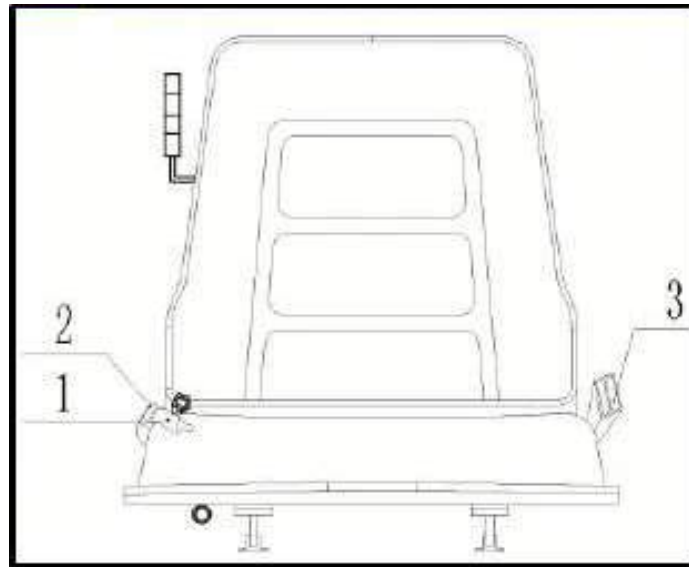

Additional check for Duo-sensitive belts

- For models with driver's compartment: Move the seat forward or tip the backrest completely forward.

CAUTION

When opening the bonnet, take care not to strike the rear window (if fitted).

- Release the hood (4) and raise it about 30°.

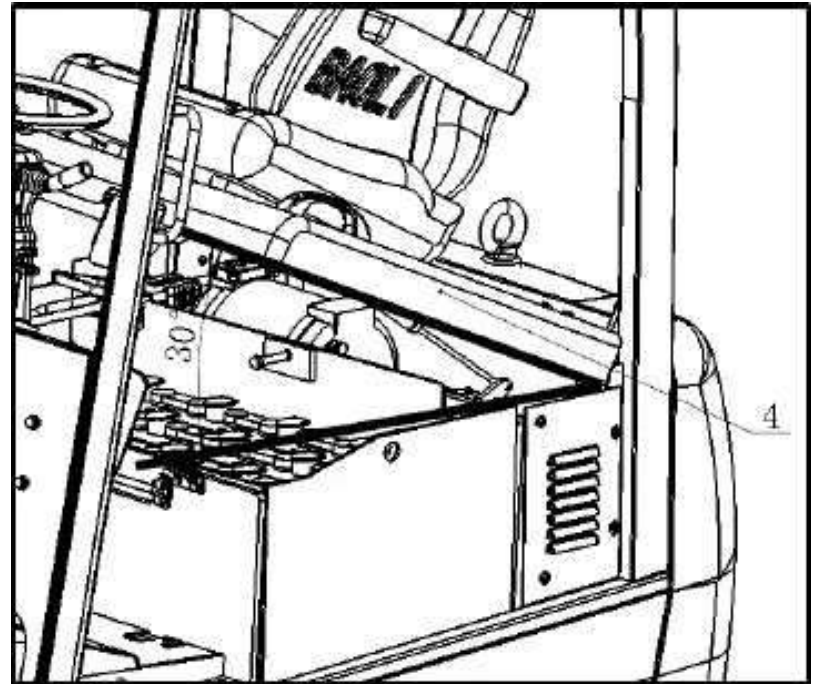

- Try to pull the belt (1). The automatic blocking mechanism must not allow the belt to come out of the winder (2).

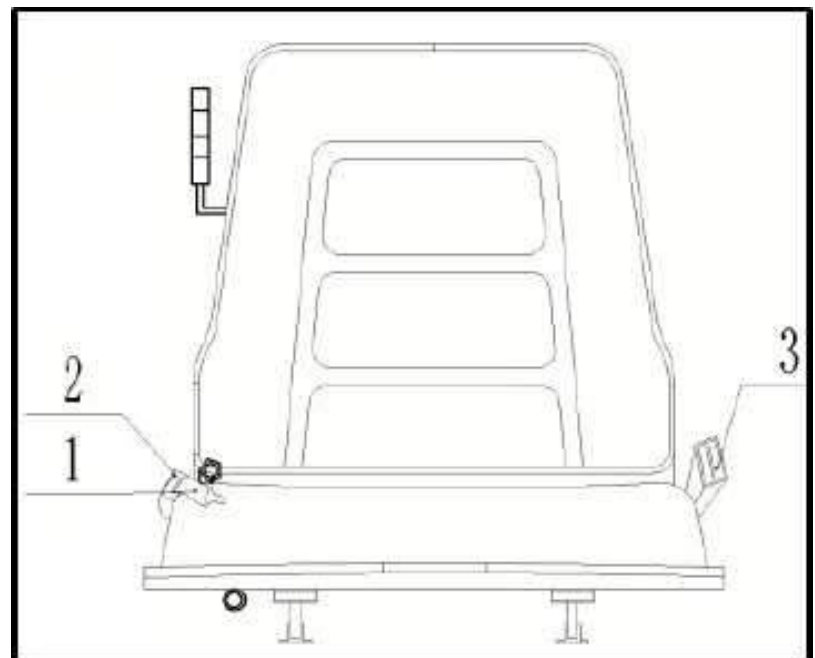

Fork arm check

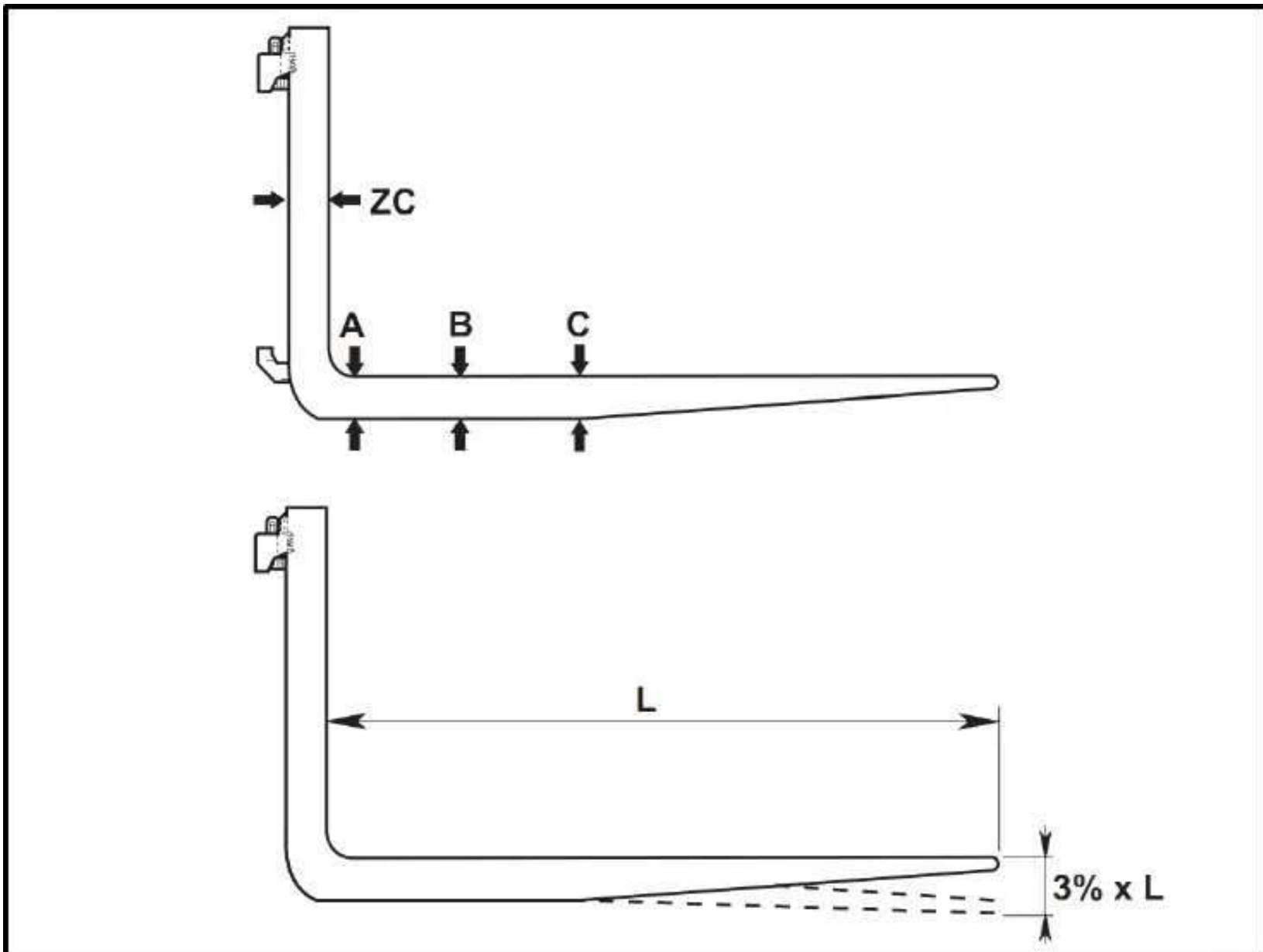

The fork arm check must be carried out thoroughly by expert personnel, in order to detect all damage, breakage, deformation, etc., which could reduce safety in use.

- Wear check

Measure the sample section (ZC) as indicated in the drawing and compare it with sections A, B, C. Maximum wear permitted at points A, B, C, is 10% compared with the sample section.

- Deformation check

With the fork arms mounted on the plate in the working position, check that the height difference of the tips is not greater than 3% of the length of the same. E.g.: length (L) cm 120 = $(120 \times 3/100) = 3.6\text{cm}$

- Check for cracks

Visually check that there are no cracks on the fork arms, especially in the fork heel and attachment areas. In case of doubt, check using a dye penetrant test.

Putting out of Commission

General Information

The operations to be performed for "Temporary decommissioning" and "Permanent decommissioning" are listed in this chapter.

Temporary Putting Out of Commission

The following operations must be performed when the forklift is not going to be used for a long time:

- Clean the forklift as indicated in the "Maintenance" chapter and put it in a dust-free and dry room.
- Lower the forks.
- Lightly grease all of the unpainted parts with oil or grease.
- Perform the lubrication operations indicated in the maintenance chapter.
- Remove the battery and put it in a room where there is no danger of freezing.
- Charge the battery at least once a month.
- Raise the forklift so that the wheels do not touch the ground; otherwise, the wheels will become at the point of contact with the floor.
- Cover the forklift with a NON-plastic sheet.

Checks and Inspections after a Long Period of Inactivity

DANGER

Perform the following operations before using the forklift:

- Clean forklift truck thoroughly.
- Check the battery charge level and reassemble it in the forklift, making sure to spread Vaseline on the terminals.
- Lubricate all of the parts provided with lubricating nipples and the chains.

- Carry out the fluid level checks.
- Perform all of the functional maneuvers of the forklift and of its safety devices both loaded and unloaded.

DANGER

Follow the instructions provided in the maintenance chapter for the operations indicated previously.

Permanent Putting Out of Commission (Demolition)

DANGER

The truck parts must be disassembled by a specialized technician.



ENVIRONMENT NOTE

Proceed as follows when it is time to scrap the truck:

- Disassemble the truck parts as far as possible (panels, lamps, battery, chains, motors, etc.), separating them based on their different nature (e.g. piping, rubber parts, lubricants, aluminium, ferrous material, etc.).
- Before scrapping, inform the appropriate authorities in writing, in compliance with the current regulations in the relative COUNTRY.
- After having received authorization from the competent authorities, dispose of the components following the prescriptions of the current regulations on the subject.

Disposal of harmful substances

When disposing of harmful substances, such as lubricants, batteries, etc., consult the current legislation in the relative country and operate accordingly.



NOTE

Consult the specific battery manual for further information.



NOTE

The customer is solely responsible for any irregularities with regard to the interpretation and application of current legislation on the subject, committed by him before, during or after scrapping and disposal of the truck parts.

Supply Table

Element to be supplied	Quantity	Lubricants	International specifications
Hydraulic circuit	24L	L-HM46&L-HM32	ISOVG30
Bearings and grease nipples	0.1 kg	JISK2220/2#	
Axle support		Grease: MOLYCOTETypeP40	
Gear box	0.6 L	Oil: KBET15/18: ATF220 KBET20: AXF80W90	SAE-80W/API GL4/UTTO
Chains		Lubricant STRUCTOV FHD	ISO VG 150
Oil-immersed brakes	0.2 L		dot3

Technical data

Overall dimensions for three-wheel truck

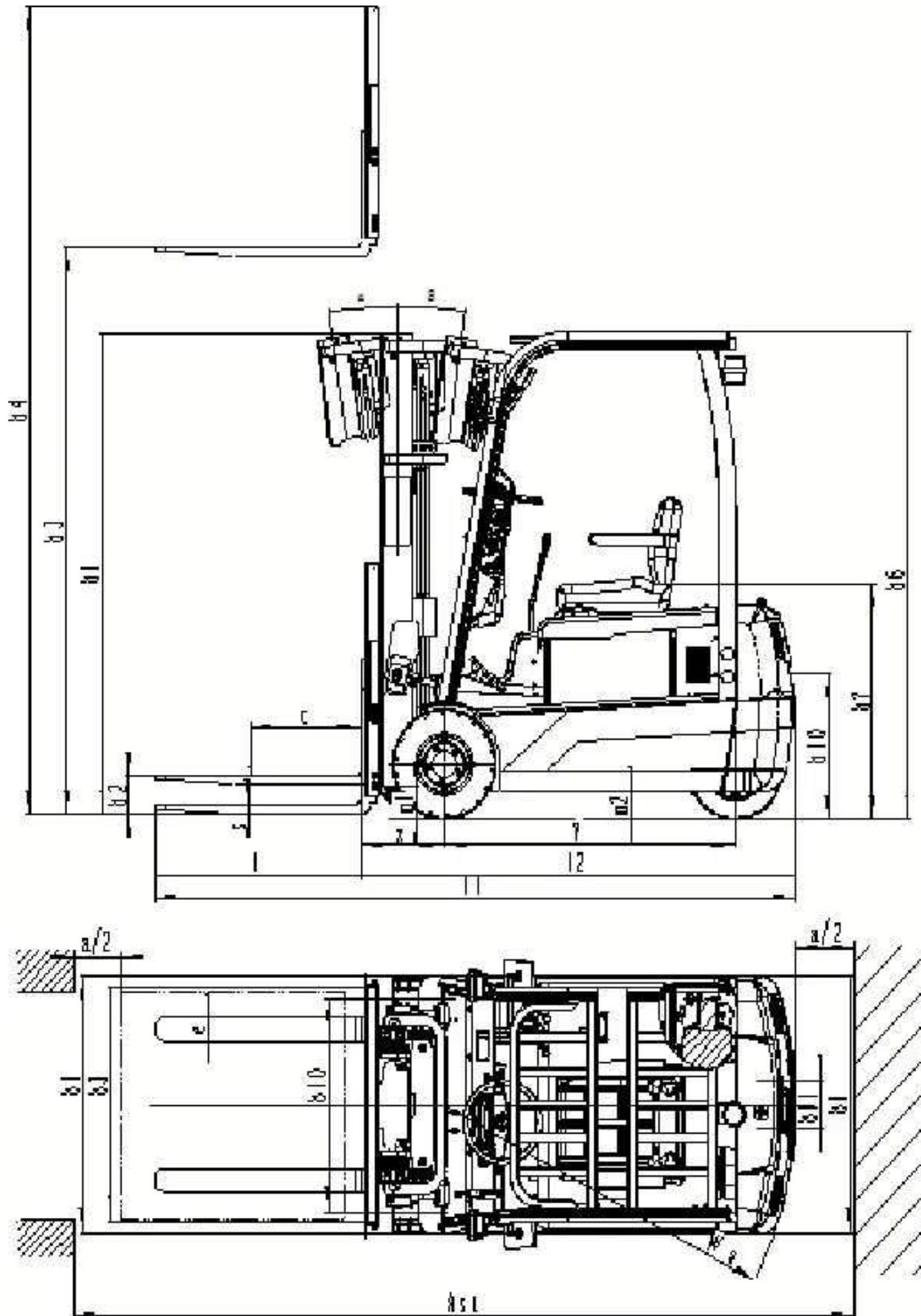

SFE15T/18T/20T Datasheet Conforms to VDI 2198

P	Manufacturer (abbreviation)			SHANTUI	SHANTUI	SHANTUI
1.2	Manufacturer's type designation			SFE15T	SFE18T	SFE20T
1.3	Drive: electric (battery or mains), diesel, petrol, fuel gas			Electric	Electric	Electric
1.4	Operator type: hand, pedestrian, standing, seated, order-picker			Seated	Seated	Seated
1.5	Rated capacity/rated load	Q	kg	1500	1800	2000
1.6	Load centre distance	c	mm	500	500	500
1.8	Load distance, centre of drive axle to fork	x	mm	365	365	396
1.9	Wheel base	y	mm	1295	1295	1435
2.1	Service weight		kg	3130	3260	3650
2.2	Axle loading, laden front/rear		kg	3900/730	4530/530	4970/680
2.3	Axle loading, unladen front/rear		kg	1500/1630	1500/1760	1650/2000
3.1	Tyres: solid rubber, superelastic, pneumatic, polyurethane			S/E	S/E	S/E
3.2	Tyre size, front			18x7-8	18x7-8	200/50-10
3.3	Tyre size, rear			16x6-8	16x6-8	16*6-8
3.5	Wheels, number front/rear (x = driven wheels)			2x/2	2x/2	2x/2
3.6	Tread, front	b ₁₀	mm	890	890	925
3.7	Tread, rear	b ₁₁	mm	205	205	205
4.1	Tilt of mast/fork carriage forward/backward	α / β	°	5/7	5/7	5/7
4.2	Height, mast lowered	h ₁	mm	2005	2005	2007
4.3	Free lift	h ₂	mm	100	100	138
4.4	Lift	h ₃	mm	3000	3000	3000
4.5	Height, mast extended	h ₄	mm	3945	3945	4040
4.7	Height of overhead guard (cabin)	h ₆	mm	2015	2015	2075
4.8	Seat height relating to SIP/stand height	h ₇	mm	958	958	1065
4.12	Coupling height	h ₁₀	mm	600	600	637
4.19	Overall length	l ₁	mm	2850	2850	3103
4.20	Length to face of forks	l ₂	mm	1930	1930	2033
4.21	Overall width	b ₁ /b ₂	mm	1066	1066	1120
4.22	Fork dimensions DIN ISO 2331	s / e / l	mm	35/120/920	35/120/920	40*122*1070
4.23	Fork carriage ISO 2328, class/type A, B			ISO II/A	ISO II/A	ISO II/A
4.24	Fork-carriage width	b ₃	mm	968	968	1040
4.31	Ground clearance, laden, below mast, laden/unladen	m ₁	mm	120	120	114/124
4.32	Ground clearance, centre of wheelbase, laden/unladen	m ₂	mm	110	110	105/110
4.34	Aisle width predetermined load dimensions	A _{st}	mm			
4.34.1	Working aisle width with pallet 1000 x 1200 crossways****	A _{st}	mm	3025	3025	3380
4.34.2	Working aisle width with pallet 800 x 1200 lengthways****	A _{st}	mm	3225	3225	3485
4.35	Turning radius	W _a	mm	1550	1550	1640
5.1	Travel speed, laden/unladen		km/h	14/15.5	13.5/15	13/14
5.2	Lift speed, laden/unladen		m/s	0.30/0.47	0.30/0.47	0.30/0.40
5.3	Lowering speed, laden/unladen		m/s	0.46/0.42	0.48/0.42	0.46/0.42
5.6	Max. drawbar pull, laden/unladen(5 minute)		N	/8.7	/8.8	/9.7
5.8	Max. gradeability, laden/unladen(5 minute)		%	20/20	20/20	15/18
5.10	Service brake			Electric/mechanical	Electric/mechanical	Electric/mechanical
6.1	Drive motor rating S2 60 min		kW	2x6.5	2x6.5	2x6.5
6.2	Lift motor rating at S3 15 %		kW	15	15	15
6.4	Battery voltage	U	V	48	48	48
6.4.1	nominal capacity K ₅	K ₅	Ah	505/525/595	505/525/595	625/700
6.5	Battery weight		kg	810~920	810~920	900~990
10.1	Operating pressure for attachments		bar	160	160	125
10.7	Sound pressure level at the driver's seat		dB(A)	≤75	≤75	≤75
	Drive control			AC	AC	AC

* The specified rated lift takes into consideration the tyre deflection and the tolerances of the tyre diameter
** Without cab. Different values with cab
*** Fork overhang not included
**** For tele-, NiHo- and triplex mast
Note: E=Environmental protection solid tyre; S=solid tyre ; P=Pneumatic tire



NOTE

The values shown refer to standard outfits;
they are indicative only and not binding.

<https://www.forkliftpdfmanuals.com/>

Alternative lift characteristics

mast type	max. height	Rated capacity		height		free-lift height		mast angle
		load center 500mm		closed height	height with carriage	without carriage	with carriage	front/back
		1.5T	1.8T					
VM Standard wide-view	2500	1500	1800	1745	3542	140	140	5/7
	2700			1845	3742	140	140	
	3000			2005	4042	140	140	
	3250			2120	4292	140	140	
	3300			2145	4342	140	140	
	3500			2245	4542	140	140	
	4000	1300	1600	2545	5042	140	140	
VFM Full free flex	2500	1500	1800	1745	3542	1250	743	5/7
	2700			1845	3742	1350	843	
	3000			2005	4042	1500	993	
	3300			2145	4342	1650	1143	
	3500			2245	4542	1690	1243	
	4000	1300	1600	2545	5042	1890	1543	
VFHM Full free triplex	4000	1300	1500	1940	5042	1400	938	3/5
	4350	1280	1400	2065	5392	1525	1063	
	4500	1250	1400	2115	5542	1575	1183	
	4700	1250	1300	2185	5742	1645	1183	
	4800	1200	1300	2215	5842	1745	1213	
	5000	1100	1200	2315	6042	1775	1313	
	5400	900	1000	2440	6442	1900	1483	
	5500	750	850	2465	6542	1925	1463	
	6000	500	650	2665	7042	2125	1663	

Remark: This data would be changed under different working condition

❖ subtract 150kg with side shifter

mast type	max. height	Rated capacity		height		free-lift height		mast angle front/back
		load center 500mm		closed height	height with carriage	without carriage	with carriage	
		2.0T						
VM Standard wide view	2500	2000		1757	3540	98	98	5/7
	2700			1857	3740	98	98	
	3000			2007	4040	98	98	
	3300			2157	4340	98	98	
	3500			2257	4540	98	98	
	4000	1800		2557	5040	98	98	3/5
VFM H 11 free duplex	2500	2000		1757	3540	1167	757	5/7
	2700			1857	3740	1267	857	
	3000			2007	4040	1417	1007	
	3300			2157	4340	1567	1157	
	3500			2257	4540	1667	1257	
	4000	1800		2557	5040	1967	1557	3/5
VFHM Full free triplex	4000	1700		2000	5035	1370	1000	3/5
	4350	1550		2125	5385	1495	1125	
	4500	1450		2175	5535	1545	1175	
	4700	1350		2240	5735	1610	1240	
	5000	1200		2418	6035	1788	1418	
	5400	1000		2618	6435	1988	1618	
	5500	950		2652	6535	2022	1652	
	6000	750		2885	7035	2255	1885	

Remark: This data would be changed under different working condition

❖ subtract 150kg with side shifter

Three-wheel truck tyre characteristics

WHEELS		
Type	solid	
	front	rear
KBET15/18	18x7-8	16×6 -8
KBET20	200/50	16×6 -8

Battery dimensions and weights

Truck type	Voltage V	Capacity Ah	Weight kg
KBET15/18	48	505/525/595	810~920
KBET20	48	625/700	900~990

Lamps

Front light	12V-55W
Direction indicators lights	12V-21W
Breadth indicators lights	12V-5W
Tail and stop lights	12V-21W
Reversing lights	12V-10W
Flashing beacon	12V-2W

7

DIAGRAMS

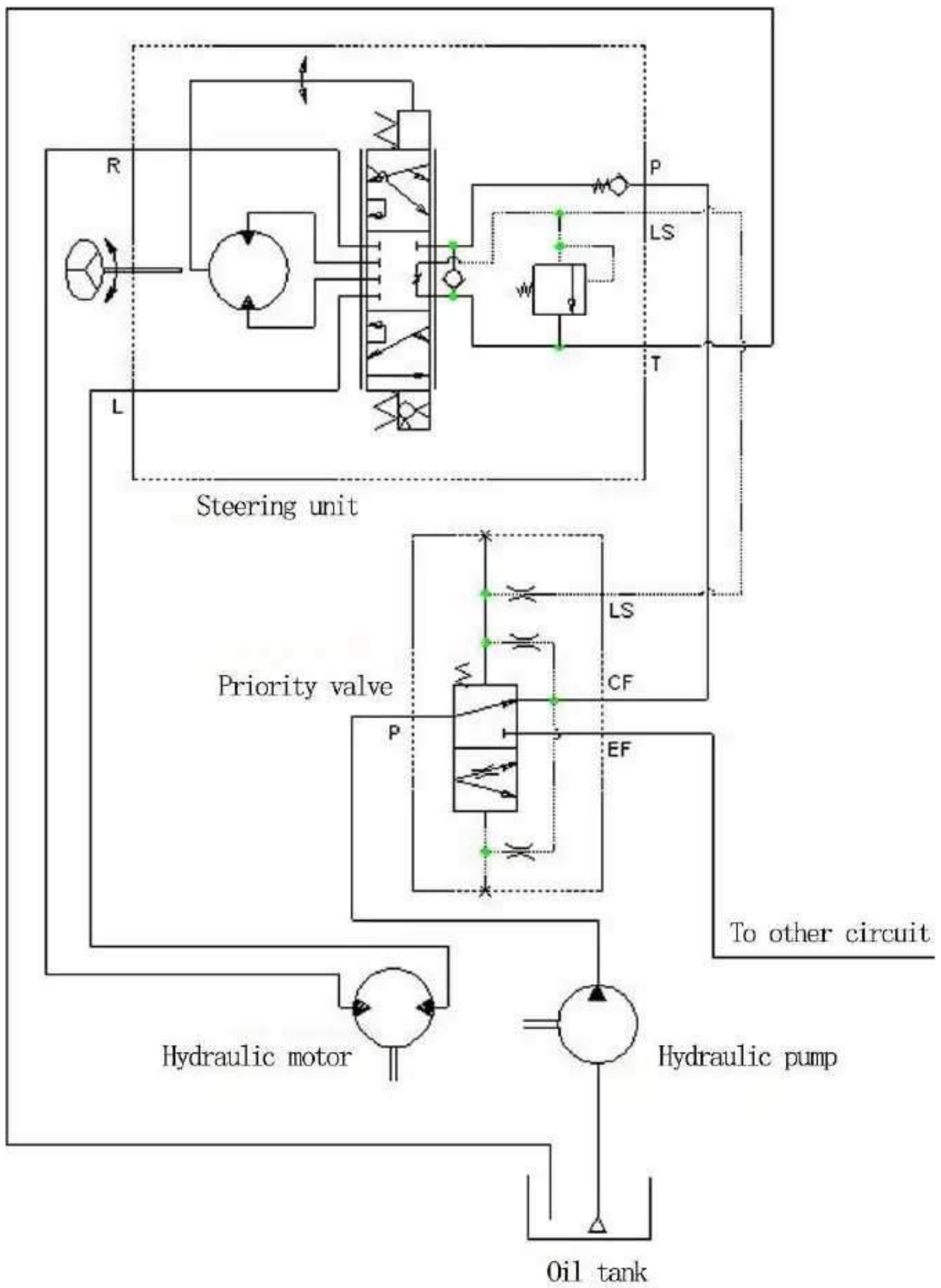

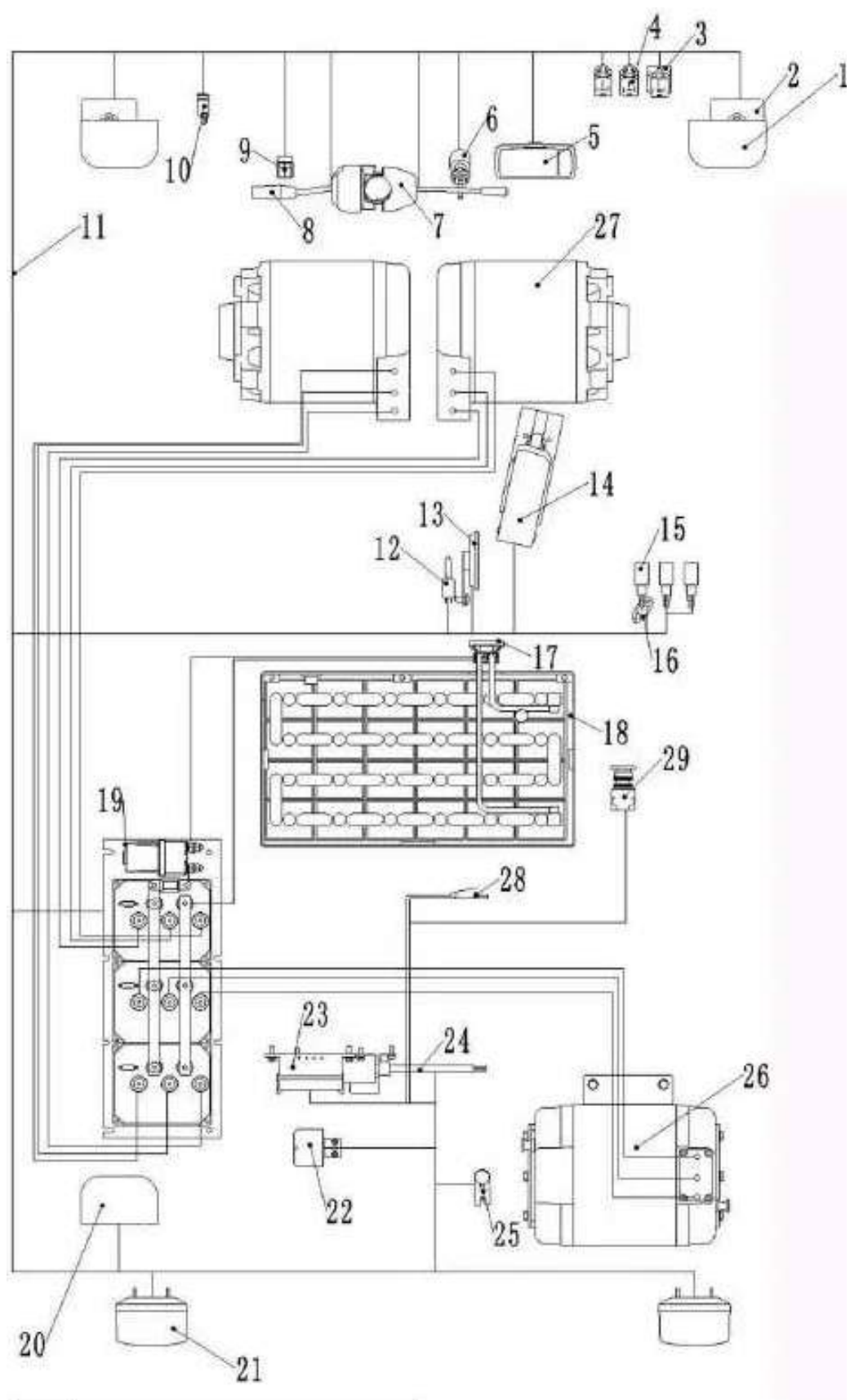

1.	Head lamp
2.	Front combination lamp
3.	Flash light
4.	Inching relay
5.	Meter assy
6.	Start switch
7.	Turning switch
8.	Direction switch
9.	Lamp switch
10.	Hand brake
11.	Main harness
12.	Brake switch
13.	Horn
14.	Accelerator
15.	Inching switch
	Lift potentiometer
16.	Socket assy
17.	Battery assy
18.	Battery assy
19.	Controller assy
20.	Rear working lamp
21.	Rear tail lamp
22.	Back-up buzzer
23.	Fuse box
24.	DC commutator
25.	Steering potentiometer
26.	Lift motor
27.	Traction motor
28.	Seat switch
29.	Emergency switch