



**MANITOU NORTH AMERICA, INC.**

6401 IMPERIAL DRIVE  
WACO, TX 76712-6803

For Parts Orders contact your Manitou North America Dealer or call:  
**Manitou North America, Inc. Parts Dept.** (800) 425-3727 or (254) 799-0232  
Parts Dept. Fax (254) 867-6504 Website: [www.manitou-na.com](http://www.manitou-na.com)

**MLA 628 -120 LSU POWERSHIFT  
Series 3-E2**

**OPERATOR'S MANUAL**

**THIS OPERATOR'S MANUAL MUST BE KEPT IN THE LIFT TRUCK AND MUST BE READ AND UNDERSTOOD BY OPERATORS.**

**547866AS  
R11-10**







**- INTRODUCTION TO SAFETY -**

*- ROUGH TERRAIN FORKLIFT TRUCK*

*GENERAL SAFETY STANDARDS ----- I*

*- SAFETY MESSAGES ----- VII*

*- SAFETY DECALS ----- VIII*

**- TABLE OF CONTENTS -**

*- OPERATING AND SAFETY INSTRUCTIONS ----- 1 - 3*

*- DESCRIPTION ----- 2 - 3*

*- MAINTENANCE ----- 3 - 3*

*- PICKING UP THE ATTACHMENTS ----- 4 - 3*



**ROUGH TERRAIN FORKLIFT TRUCK**  
**GENERAL SAFETY STANDARDS**

## **ROUGH TERRAIN FORKLIFT TRUCK GENERAL SAFETY STANDARDS**

### **STUDY THE OPERATOR/SERVICE MANUALS**

The information in this manual provides general instructions for the safe operation and maintenance of your forklift truck. This information is vital and must be clearly understood by the operator and serviceman. Study this manual and the Rough Terrain Forklift Safety Manual (part no. 422494) thoroughly and carefully before operating or servicing your forklift. Contact your dealer or Manitou North America, Inc. if you have any questions concerning your forklift, its operation, service or parts. Keep both manuals in the literature box on the forklift available for reference. If either manual becomes illegible or is missing, contact your dealer for replacements immediately. This manual cannot cover every situation that might result in an accident. It is the responsibility of the operator to always remain alert for potential hazards and be prepared to avoid them!

### **ADDITIONAL RECOMMENDED LITERATURE:**

ANSI / ITSDF B56.6 is the national consensus standard for rough terrain forklift trucks. It contains rules about forklift safety, maintenance, safe operation, training, and supervision. Forklift owners should learn this standard and make it available for their operators, service personnel, and supervisors. These standards can be obtained, free of charge, from the Industrial Truck Standards Development Foundation (ITSDF) on their website at [www.itsdf.org](http://www.itsdf.org). The following references are examples from the standard, addressing forklift operators:

### **A.) OPERATOR TRAINING QUALIFICATIONS**

- 1.) The user shall ensure that operators understand that safe operation is the operator's responsibility. The user shall ensure that operators are knowledgeable of, and observe, all safety rules and practices.
- 2.) Create an effective operator training program centered around user company's policies, operating conditions, and rough terrain forklift trucks. The program should be presented completely to all new operators and not be condensed for those claiming previous experience.
- 3.) Information on operator training is available from several sources, including rough terrain forklift truck manufacturers, users, government agencies, etc.
- 4.) An operator training program should consist of the following:
  - a.) careful selection of the operator, considering physical qualifications, job attitude, and aptitude;
  - b.) emphasis on safety of stock, equipment, operator, and other personnel;
  - c.) citing of rules and why they were formulated;
  - d.) basic fundamentals of rough terrain forklift truck and component design as related to safety, e.g., in.-lb (N-m) loading, mechanical limitations, center of gravity, stability, etc.;
  - e.) introduction to equipment, control locations, and functions. Explain how they work when used properly and problems when used improperly.
  - f.) supervise practice on operating course remote from normal activity and designed to simulate actual operations, e.g., lumber stacking, elevating shingles to the roof, etc.;
  - g.) oral, written, and operational performance tests and evaluations during and at completion of the course;
  - h.) refresher courses, which may be condensed versions of the primary course, and periodic "on job" operator evaluation;
  - i.) understanding of nameplate data and operator instructions and warning information appearing on the rough terrain forklift truck.

### **B.) GENERAL SAFETY PRACTICES**

- 1.) Rough terrain forklift trucks can cause injury if improperly used or maintained.
- 2.) Only authorized operators trained to adhere strictly to all operating instructions shall be permitted to operate rough terrain forklift trucks. Unusual operating conditions may require additional safety precautions, training, and special operating instructions.
- 3.) Modifications and additions which affect capacity or safe operation shall not be performed without the manufacturer's prior written approval. Where such authorization is granted, capacity, operation, and maintenance instruction plates, tags, or decals shall be changed accordingly.
- 4.) If the rough terrain forklift truck is equipped with front end attachment(s) or optional forks, the user shall see that the truck is marked to identify the forks or attachment(s), show the approximate weight of the truck and fork or attachment combination, and show the capacity of the truck with forks or attachment(s) at maximum elevation with load laterally centered.
- 5.) The user shall see that all nameplates and caution and instruction markings are in place and legible.
- 6.) The user shall consider that changes in load dimension may affect rough terrain forklift truck capacity.



**ROUGH TERRAIN FORKLIFT TRUCK GENERAL SAFETY STANDARDS (cont.)****B.) GENERAL SAFETY PRACTICES (cont.)**

- 7.) Where steering can be accomplished with either hand and the steering mechanism is of a type that prevents road reactions from causing the handwheel to spin (power steering or equivalent), steering knobs may be used. When used, steering knobs shall be of a type that can be engaged by the operator's hand from the top and shall be within the periphery of the steering handwheel.
- 8.) Experience has shown that rough terrain forklift trucks which comply with stability requirements are stable when properly operated. However, improper operation, faulty maintenance, or poor housekeeping may contribute to a condition of instability and defeat the purpose of the requirements.
- 9.) Users shall give consideration to special operating conditions. The amount of forward and rearward tilt to be used is governed by the application. Although the use of maximum rearward tilt is allowable under certain conditions, such as traveling with the load lowered, the stability of a rough terrain forklift truck as determined by standardized tests does not encompass consideration for excessive tilt at high elevations or the operation of trucks with excessive off-center loads.
- 10.) Some of the conditions which may affect stability are ground and floor conditions, grade, speed, loading (rough terrain forklift trucks equipped with attachments behave as partially loaded trucks even when operated without a load on the attachment), dynamic and static forces, improper tire inflation, and the judgement exercised by the operator.

**C.) OPERATING SAFETY RULES AND PRACTICES**

- 1.) Safe operation is the responsibility of the operator.
- 2.) This equipment can be dangerous if not used properly. The operator shall develop safe working habits and also be aware of hazardous conditions in order to protect himself, other personnel, the rough terrain forklift truck, and other material.
- 3.) The operator shall be familiar with the operation and function of all controls and instruments before undertaking to operate the rough terrain forklift truck.
- 4.) Before operating any rough terrain forklift truck, truck operators shall have read and be familiar with the operator's manual for the particular truck being operated.
- 5.) Before starting to operate the rough terrain forklift truck:
- a.) be in operating position and fasten seat belt;
  - b.) place directional controls in neutral;
  - c.) apply brakes;
  - d.) start engine.
- 6.) Do not start or operate the rough terrain forklift truck, any of its functions, or attachments from any place other than the designated operator's position.
- 7.) Keep hands and feet inside the operator's designated area or compartment. Do not put any part of the body outside the operator compartment of the rough terrain forklift truck.
- 8.) Never put any part of the body into the mast structure or between the mast and the rough terrain forklift truck.
- 9.) Never put any part of the body within the reach mechanism of the rough terrain forklift truck or other attachments.
- 10.) Understand rough terrain forklift limitations and operate the truck in a safe manner so as not to cause injury to personnel.
- 11.) Do not allow anyone to stand or pass under the elevated portion of any rough terrain forklift truck, whether empty or loaded.
- 12.) Do not permit passengers to ride on rough terrain forklift trucks.
- 13.) Check clearance carefully before driving under electrical lines, bridges, etc.
- 14.) A rough terrain forklift truck is attended when the operator is less than 25 ft (7.6m) from the truck, which remains in his view.
- 15.) A rough terrain forklift truck is unattended when the operator is 25ft (7.6m) or more from the truck, which remains in his view, or whenever the operator leaves the truck and it is not in his view.
- 16.) Before leaving the operator's position:
- a.) bring rough terrain forklift truck to a complete stop;
  - b.) place directional controls in neutral;
  - c.) apply the parking brake;
  - d.) lower load-engaging means fully, unless supporting an occupied elevated platform;
  - e.) stop the engine;
  - f.) if the rough terrain forklift truck must be left on an incline, block the wheels;
  - g.) fully lower the load-engaging means.
- 17.) Maintain a safe distance from the edge of ramps, platforms, and other similar working surfaces.
- 18.) Do not move railroad cars or trailer with a rough terrain forklift truck.

**ROUGH TERRAIN FORKLIFT TRUCK GENERAL SAFETY STANDARDS (cont.)****C.) OPERATING SAFETY RULES AND PRACTICES (cont.)**

- 19.) Do not use a rough terrain forklift truck for opening or closing railroad car doors.
- 20.) In areas classified as hazardous, use only rough terrain forklift trucks approved for use in those areas.
- 21.) Report all accidents involving personnel, building structures, and equipment to the supervisor or as directed.
- 22.) Do not add to, or modify, the rough terrain forklift truck.
- 23.) Do not block access to fire aisles, stairways, and fire equipment.
- 24.) For rough terrain forklift trucks equipped with a differential lock, the lock should not be engaged when driving on the road or at high speeds or when turning. If the lock is engaged when turning, there could be loss of steering control.
- 25.) Observe all traffic regulations including authorized speed limits. Under normal traffic conditions, keep to the right, maintain a safe distance, based on speed of travel, from the truck ahead; and keep the truck under control at all times.
- 26.) Yield the right-of-way to pedestrians and emergency vehicles such as ambulances and fire trucks.
- 27.) Do not pass another truck traveling in the same direction at intersections, blind spots, or at other dangerous locations.
- 28.) Slow down and sound the audible warning device(s) at cross-aisles and other locations where vision is obstructed.
- 29.) Cross railroad tracks at an angle wherever possible. Do not park closer than 6 ft (1.8m) to the nearest rail of a railroad track.
- 30.) Keep a clear view of the path of travel and observe other traffic, personnel, and safe clearances.
- 31.) If the load being carried obstructs forward view, travel with the load trailing.
- 32.) Ascend or descend grades slowly and with caution.
- a.) When ascending or descending grades in excess of 5%, loaded rough terrain forklift trucks should be driven with the load upgrade.
  - b.) Unloaded rough terrain forklift trucks should be operated on all grades with the load-engaging means downgrade.
  - c.) On all grades, the load and load-engaging means shall be tilted back, if applicable, and raised only as far as necessary to clear the road surface.
  - d.) Avoid turning, if possible, and use extreme caution on grades, ramps, or inclines; normally travel straight up or down.
- 33.) Under all travel conditions, operate the rough terrain forklift truck at a speed that will permit it to be brought to a stop in a safe manner.
- 34.) Travel with load-engaging means or load low and, where possible, tilted back. Do not elevate the load except during stacking.
- 35.) Make starts, stops, turns, or direction reversals in a smooth manner so as not to shift load and/or overturn the rough terrain forklift truck.
- 36.) Do not indulge in stunt driving or horseplay.
- 37.) Slow down for wet and slippery surfaces.
- 38.) Before driving over a dockboard or bridge plate, be sure that it is properly secured. Drive carefully and slowly across the dockboard or bridge plate, and never exceed its rated capacity.
- 39.) Do not drive rough terrain forklift trucks onto any elevator unless specifically authorized to do so. Approach elevators slowly, and then enter squarely after the elevator car is properly leveled. Once on the elevator, neutralize the controls, shut off engine, and set brakes. It is advisable that all other personnel leave the elevator before truck is allowed to enter or leave.
- 40.) Avoid running over loose objects on the roadway surface.
- 41.) When negotiating turns, reduce speed to a safe level, and turn steering handwheel in a smooth sweeping motion. Except when maneuvering at a very low speed, turn the steering handwheel at a moderate, even rate.
- 42.) Use special care when traveling without load, as the risk of lateral overturning is greater.
- 43.) Improper use of stabilizer controls (if so equipped) could cause rough terrain forklift truck upset. Always lower the carriage before operating stabilizer controls.
- 44.) For rough terrain forklift trucks equipped with lateral leveling:
- a.) Always level the frame before raising the boom or mast, with or without a load.
  - b.) Lateral leveling should not be used to position an elevated load; instead, lower the load and reposition the rough terrain forklift truck.
- 45.) Handle only stable or safely arranged loads.
- a.) When handling off-center loads which cannot be centered, operate with extra caution.
  - b.) Handle only loads within the capacity of the rough terrain forklift truck.
  - c.) Handle loads exceeding the dimensions used to establish rough terrain forklift truck capacity with extra caution. Stability and maneuverability may be adversely affected.

## ***ROUGH TERRAIN FORKLIFT TRUCK GENERAL SAFETY STANDARDS (cont.)***

### **C.) OPERATING SAFETY RULES AND PRACTICES (cont.)**

- 46.) When attachments are used, extra care shall be taken in securing, manipulating, positioning, and transporting the load. Operate rough terrain forklift trucks equipped with attachments as partially loaded trucks when not handling a load.
- 47.) Completely engage the load with the load-engaging means. Fork length should be at least two-thirds of load length. Where tilt is provided, carefully tilt the load backward to stabilize the load. Caution should be used in tilting backward with high or segmented loads.
- 48.) Use extreme care when tilting load forward or backward, particularly when high tiering. Do not tilt forward with load-engaging means elevated except to pick up or deposit a load over a rack or stack. When stacking or tiering, use only enough backward tilt to stabilize the load.
- 49.) ~~The handling of suspended loads by means of a crane arm (boom) or other device can introduce dynamic forces affecting the stability of a rough terrain forklift truck. Grades and sudden starts, stops, and turns can~~ cause the load to swing and create a hazard if not externally stabilized. When handling suspended loads:
- a.) do not exceed the truck manufacturer's capacity of the rough terrain forklift truck as equipped for handling suspended loads.
  - b.) only lift the load vertically and never drag it horizontally;
  - c.) transport the load with the bottom of the load and the mast as low as possible;
  - d.) with load elevated, maneuver the rough terrain forklift truck slowly and cautiously, and only to the extent necessary to permit lowering to the transport position;
  - e.) use tag lines to restrain load swing whenever possible.
- 50.) At the beginning of each shift and before operating the rough terrain forklift truck, check its condition, giving special attention to:
- a.) tires and their inflation pressure
  - b.) warning devices
  - c.) lights
  - d.) lift and tilt systems, load-engaging means, chains, cables, and limit switches
  - e.) brakes
  - f.) steering mechanism
  - g.) fuel system(s)
- 51.) If the rough terrain forklift truck is found to be in need of repair or in any way unsafe, or if it contributes to an unsafe condition, the matter shall be reported immediately to the user's designated authority, and the truck shall not be operated until it has been restored to safe operating condition.
- 52.) If during operation the rough terrain forklift truck becomes unsafe in any way, the matter shall be reported immediately to the user's designated authority, and the truck shall not be operated until it has been restored to safe operating condition.
- 53.) Do not make repairs or adjustments unless specifically authorized to do so.
- 54.) When refueling, smoking in the area shall not be permitted, the engine shall be stopped, and the operator shall not be on the rough terrain forklift truck.
- 55.) Spillage of oil or fuel shall be carefully and completely absorbed or evaporated and fuel tank cap replaced before restarting engine.
- 56.) Do not use open flames when checking electrolyte level in storage batteries, liquid level in fuel tanks, or the condition of LPG fuel lines and connectors.
- 57.) Do not lift personnel with the forklift. If the forklift must be used to lift people, precautions for the protection of the personnel must be taken (see ITSDF B56.6, chapter 5.15 Elevating Personnel).

## D.) SUSPENDED LOADS

A jib or truss boom should ONLY be used to lift and place loads when the machine is stationary and the frame is level. Transporting suspended loads must ALWAYS be done slowly and cautiously, with the boom and load as low as possible. Use taglines to restrict loads from swinging, to avoid overturn.

The handling of suspended loads by means of a truss boom or other similar device can introduce dynamic forces affecting the stability of the machine that are not considered in the stability criteria of industry test standards. Grades and sudden starts, stops and turns can cause the load to swing and create a hazard.

### Guidelines for "Free Rigging / Suspended Loads"

1. DO NOT exceed the rated capacity of the telescopic handler as equipped for handling suspended loads. The weight of the rigging must be included as part of the load.
2. During transport, DO NOT raise the load more than 12 inches (305 mm) above the ground, or raise the boom more than 45 degrees.
3. Only lift the load vertically – NEVER drag it horizontally.
4. Use multiple pickup points on the load when possible. Use taglines to restrain the load from swinging and rotating.
5. Start, travel, turn and stop SLOWLY to prevent the load from swinging. DO NOT exceed walking speed.
6. Inspect rigging before use. Rigging must be in good condition and in the U.S. comply with OSHA regulation §1910.184, "Slings," or §1926.251, "Rigging equipment for material handling."
7. Rigging equipment attached to the forks must be secured such that it cannot move either sideways or fore and aft. The load center must not exceed 24 inches (610 mm).
8. DO NOT lift the load with anyone on the load, rigging or lift equipment, and NEVER lift the load over personnel.
9. Beware of the wind, which can cause suspended loads to swing, even with taglines.
10. DO NOT attempt to use frame-leveling to compensate for load swing.



### WARNING

**U.S. OSHA regulations effective November 8, 2010 (29 CFR Part 1926, Subpart CC - Cranes and Derricks in Construction) include requirements for employers that use powered industrial trucks ("forklifts") configured to hoist (by means of a winch or hook) and move suspended loads horizontally. In particular, this regulation applies to any rough-terrain forklift (e.g., "telescopic handler") equipped with a jib or truss boom with a hook (with or without a winch), or a hook assembly attached to the forks. [Note: This regulation is in addition to the OSHA regulation that requires specific forklift operator training: §1910.178(I).]**

**When a forklift / telescopic handler is configured and used for hoisting, the employer must ensure that:**

1. **Forklift, lift equipment and rigging have been inspected (each shift, month and year) and are in good, safe condition and properly installed.**
2. **An operator's manual and applicable load charts are on the forklift.**
3. **Work zone ground conditions can support the equipment and load. Any hazardous conditions in the work area have been identified, and the operator notified.**
4. **Equipment is being used within its rated capacity and in accordance with the manufacturer's instructions.**

VI

5. **Operator and crew members have been trained in the safe use and operation of the equipment, including how to avoid electrocution.**
6. **During use, no part of the equipment, load line or load will be within the minimum clearance distance specified by OSHA [10 feet (3.0 m), and more for lines rated over 50 kV] of any energized power line, and any taglines used are non-conductive.**

<https://www.forkliftpdfmanuals.com/>

7. **In addition, for lift equipment with a rated capacity greater than 2000 lbs (907 kg), the employer**

7. In addition, for lift equipment with a rated capacity greater than 2000 lbs. (907 kg), the employer must ensure that:
- a.) An accessible fire extinguisher is on the forklift;
  - b.) Monthly and annual inspections are performed and documented, and records retained (three months for monthly, one year for annual);
  - c.) Before November 10, 2014, operators must have had the additional training and qualification / certification required by OSHA regulations §1926.1427 and §1926.1430.

**Note: Refer to the full text of the OSHA crane regulation (29 CFR Part 1926, Subpart CC) for a detailed description**

---

## **ROUGH TERRAIN FORKLIFT TRUCK GENERAL SAFETY STANDARDS (cont.)**

### **CONCLUSION:**

#### **1.) ATTEND OPERATOR TRAINING CLASSES**

The forklift operator must clearly understand all instructions concerning the safe operation of the forklift and all safety rules and regulations of the work site. They must have successfully completed a training course in accordance with the Powered Industrial Truck Standard (29 CFR 1910.178) as described by the Occupational Safety and Health Administration (OSHA). They must be qualified as to their visual, hearing, physical, and mental ability to operate the equipment safely. NEVER use drugs or alcohol while operating a forklift! NEVER operate or allow anyone to operate a forklift when mental alertness or coordination is impaired! An operator on prescription or over-the-counter medication should consult a healthcare professional regarding any side effects of the medication that may impair their ability to safely operate the forklift.

## 2.) CREATE A MAINTENANCE PROGRAM

OSHA recommends a maintenance log, listing repairs requested and completed, for each forklift. Also, "lock out tag procedures" should be utilized. If the forklift malfunctions; park it safely, remove the key, tag "Do Not Use", and report the problem to the proper authority or authorized service personnel immediately.

### **ROUGH TERRAIN FORKLIFT TRUCK GENERAL SAFETY STANDARDS (cont.)**

## 2.) CREATE A MAINTENANCE PROGRAM (cont.)

For the best forklift performance and operation, a maintenance program is required. Use the hour meter on the instrument panel to keep maintenance properly scheduled (see SECTION TWO - "Servicing Schedule"). For repairs on major components (engine, transmission, etc.), contact your nearest dealer for a Repair Manual. Do not operate a forklift that is damaged or does not function properly. Only authorized personnel may make repairs or adjustments to the lift truck. After repairs, the lift truck must be tested for safe operation before returning to service.

## 3.) FORKLIFT KNOWLEDGE

Forklift trucks can cause serious injury if improperly used or maintained. Study all of the manuals provided for your forklift model. Learn the locations and meanings of all safety decals. If any decals are illegible or missing, have them replaced immediately. Make sure all safety features provided by the original manufacturer are in place and function properly. Do not operate a forklift with damaged, missing or unsafe components. Have it repaired by authorized service personnel. Learn the functions of all controls, gauges, indicator lights, etc. on the forklift. Know the speed/gear ranges, braking and steering capabilities, load ratings and clearances. When referring to the location of forklift components, the terms "left", "right", "front", and "rear" are related to the operator seated normally, facing forward in the operator's seat. If you have any questions about the forklift, consult your supervisor. Failure to fully understand or obey safety warnings can result in serious injury or death!

## 4.) WORK SITE KNOWLEDGE

Before operating on a work site, learn the rules for movement of people, forklifts and all other traffic. Check the size, weight, and condition of the loads you will be expected to handle. Verify that they are properly secured and safe to transport. Learn where the loads are to be placed, planning your route for a safe approach, watching for hazardous conditions. Will a signal man be required to help place the load? Remove any debris which may cause tire damage or rupture. Plan your route around problem areas or have them corrected. Inform the supervisor of any unsafe conditions observed at the site. Examples of hazards: power lines, cables, low clearance structures, garage doors, telephone pole guide lines, fencing, loose lumber, building materials, drop-offs, trenches, rough/soft spots, oil spills, deep mud, steep inclines, railroad tracks, curbs, etc.. NEVER approach power lines, gas lines or other utilities with the forklift! Always verify that local, state/provincial and federal regulations have been met. Report any accidents involving personnel, building structures, and equipment to the supervisor immediately. Always remain alert - conditions are constantly changing at the work site!

## TECHNICAL SUPPORT

All data provided in this manual is subject to production changes, addition of new models, and improved product designs. If a question arises regarding your forklift, please consult your dealer or K-D Manitou, Inc. for the latest information. When ordering service parts or requesting technical information, be prepared to quote the applicable Model/Serial Numbers.

## **SAFETY MESSAGES**

**NOTE THE SAFETY ALERT SYMBOL (SHOWN BELOW). IT IDENTIFIES POTENTIAL HAZARDS WHICH, IF NOT AVOIDED MAY RESULT IN INJURY OR DEATH!** Also, observe the safety messages places throughout this manual; providing special instructions, telling you when to take precautions and to identify potential hazards. The safety messages are highlighted and outlined in a box similar to those shown in the examples below.

### SAFETY ALERT SYMBOL



<b>NOTE or NOTICE</b>
Provides information, special instructions or references about the lift truck.

<b>IMPORTANT</b> <a href="https://www.kdmanitou.com/">https://www.kdmanitou.com/</a>
Precautions which must be taken to avoid damage to the lift truck.

 **CAUTION**  
Indicates a potentially hazardous situation which, if not avoided, may result in minor or moderate injury. May also alert unsafe practices.

 **WARNING**  
Indicates a potentially hazardous situation which, if not avoided, *may result in death or serious injury!*

 **DANGER**  
Indicates an imminently hazardous situation which, if not avoided, *will result in death or serious injury.*

### **CALIFORNIA PROPOSITION 65 WARNING**

Diesel Engine Exhaust and some of its constituents are known to the State of California to cause cancer, birth defects or other reproductive harm.

**WARNING:** Battery posts, terminals and related accessories and related accessories contain lead and lead compounds. **Wash hands after handling.**

## **SAFETY DECALS**

The purpose of this chapter is to introduce you to the safety messages, decals, and nameplates found on your forklift truck. The decals are identified by name, part number, location, and a brief description. (The forklift model logos, and other misc. decals not shown, can be found in your forklift parts manual.) The decals illustrated may not be exactly the same as those installed on your forklift; installation of the decals varies depending on the forklift model, series, decal updates, etc.. The size and location of some decals limit the amount of information that can be placed upon it. For this reason, additional detailed information not found on the decals is provided through-out this manual.

Every decal placed on the lift truck is important; they are constant reminders of safety and instructions that should never be taken for granted. Even experienced operators can be seriously injured or killed by ignoring, refusing to enforce, or forgetting to follow safe operating procedures! Do not assume you know all safety issues concerning the decals. Before operating the lift truck; learn the meaning(s) of the decals as described in this manual. If any decal becomes illegible or missing, have it replaced immediately! Always replace decals using the same decal part no., unless otherwise specified by the manufacturer. For replacement decals not found in your parts manual, contact your nearest dealer. If you have any questions, contact your supervisor or nearest dealer for advice before operating your forklift!



(Boom equipped models). Location: on the brake fluid cover panel (to the left and below the dash panel).

### Safety Instructions - 420792

(Mast equipped models). Location: on or near the operator manual storage case, and/or on the dash panel.

Instructions for the forklift operator; before operating the forklift.

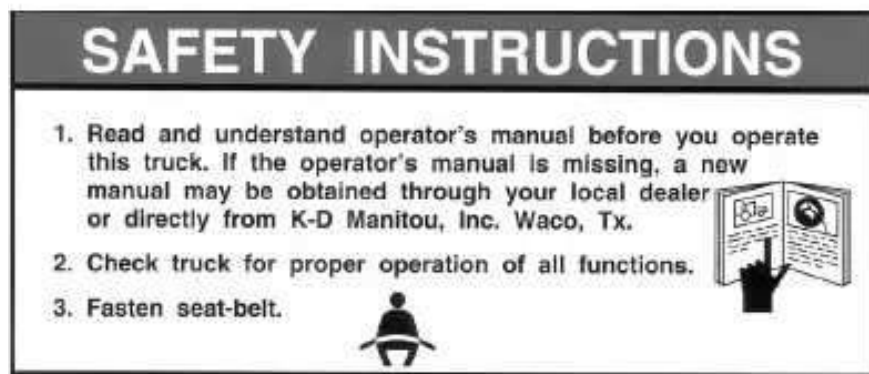

### Use of Seat Belt - 801012

(Boom equipped models). Location: to the right of the operator, near the hydraulic control lever.

Instructs the operator to always wear the seat belt during operations, and never jump from an over-turning forklift.



X

## CONTENTS

### SAFETY DECALS

#### Emergency and Parking Brake - 801010

Location: near the park brake lever.

Identifies the Emergency/Parking Brake Lever.



#### Alarm Must Sound - 496162

Location: on the dash, in direct view of the operator.

The backup alarm must sound when the forklift is placed in reverse gear.





### No Riders - 420732

Location: on the cab entrance(s), and on or near wheel fenders and engine cover.

Inform: riders are not allowed on the forklift.



### Clear of Raised Boom - 801006

(Boom equipped models). Location: on both sides of the boom nose.

Keep away from unsupported boom.



### Clear of Power Lines - 801007

(Boom equipped models). Location: on both sides of the boom nose.

Keep away from power lines.

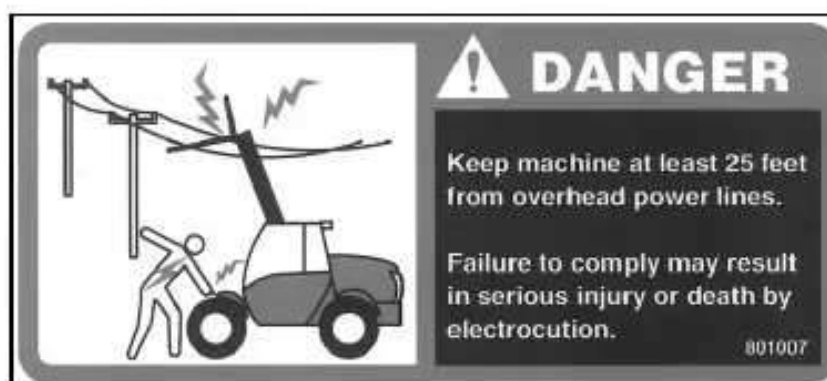

XI

## CONTENTS

### SAFETY DECALS

#### Use of Frame Leveling - 801013

(Boom equipped models). Location: to the right of the operator near the hydraulic control lever.

Frame leveling notice; load must be lowered.



#### Attachment and Boom Safety - 801009

(Boom equipped models). Location: on both sides of the boom nose.

Important reminders of attachment and boom safety.



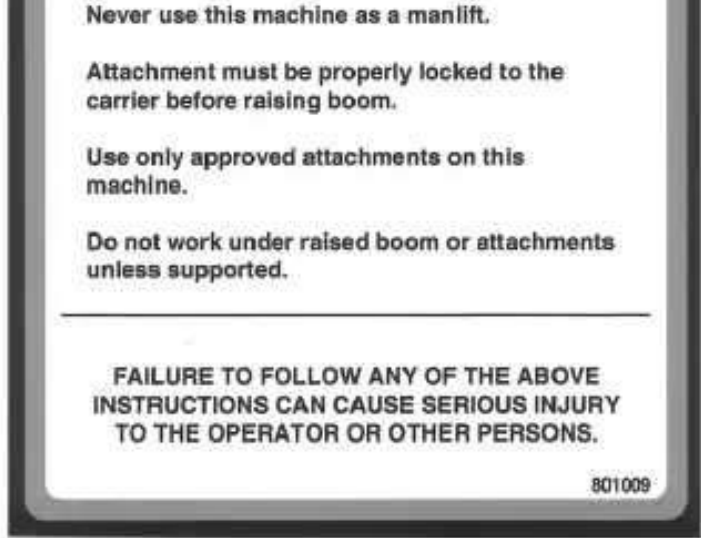

**Hydraulic Coupling - 234805**

Location: near the quick-disconnect adapters.

Stop the engine and release hydraulic pressure before changing attachments.



**Rotating Fan and Belt(s) - 801008**

Location: on the radiator near the fan, and on any fan belt/pulley cover(s).

Keep hands and clothing away from rotating fan and belts.



**CONTENTS**

**SAFETY DECALS**

**Gear Shift Pattern - 33460**

(4-speed transmission models). Location: near the gear shift lever.

Identifies the gear shift pattern of the forklift transmission.

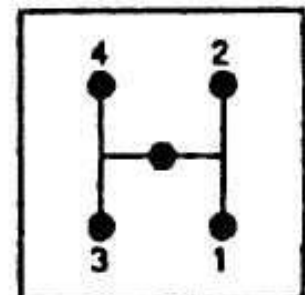

**Steering Mode - 184276**

(4 wheel steer equipped models). Location: near the steering mode selection lever.

Identifies the steering mode selection.

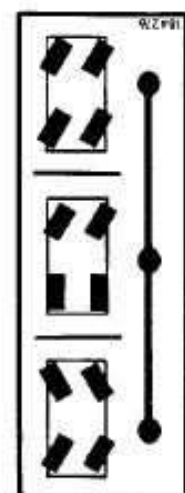

221322

**Mineral Oil (Brake Reservoir) - 221322 or 234800 has been replaced by 164091.**

Location: near the brake fluid reservoir where applicable.

Refer to the Operator/Service Manual for the correct brake fluid (mineral oil) to be used in the brake system.



234800

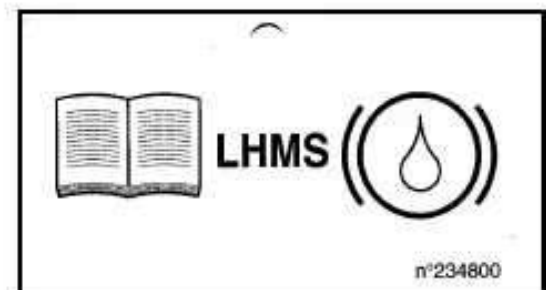

XIII

**CONTENTS**

**SAFETY DECALS**

**Hydraulic Oil - 234798 or 76573**

Location: on the hydraulic tank or filler cap.

Identifies the hydraulic reservoir (tank) or filler cap.

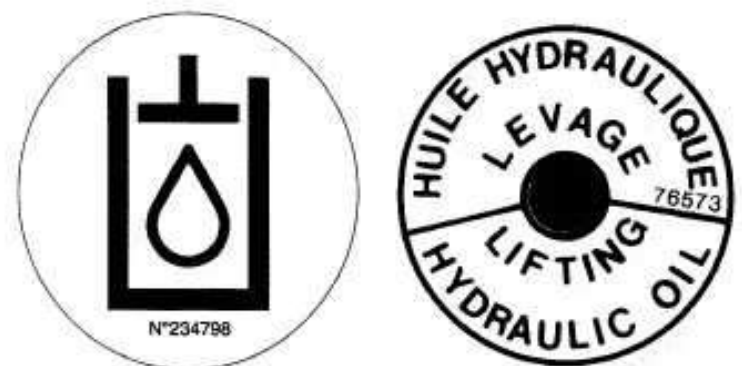

**Hydraulic Oil - 61024**

Location: on the hydraulic tank.

Identifies the hydraulic reservoir (tank).



**Anti-Freeze - 234799**

Location: on the radiator, near the radiator filler cap.

<https://www.forkliftpdfmanuals.com/>

Indicates required minimum to maximum anti-freeze protection (-22°F to -40°F)



### Diesel Fuel - 161101

Location: on the fuel tank, near the filler cap.

Identifies the fuel tank, and use of diesel fuel.

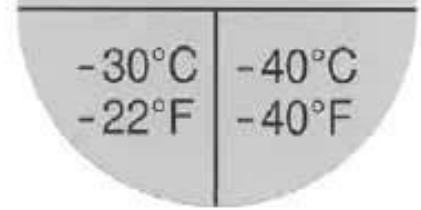

### No Step - 496735

Location: varies, depending on the forklift model.

Instructs personnel not to use the designated area as a step.



### Do Not Tow - 494918

(Hydrostatic equipped models). Location: on the dash, in view of the operator.

Towing the forklift will damage the transmission; refer to the operator's manual.



XIV

## CONTENTS

### SAFETY DECALS

#### Attachment Warning - 421016

(Boom equipped models). Location: on the boom coupler, near where the retaining shaft is installed.

Reminder to operator; install attachment retaining shaft and safety pin before operations.



#### Hook Here - 24653

Location: at points provided on the forklift, where straps or chains may be attached to secure the forklift to a trailer during transport.

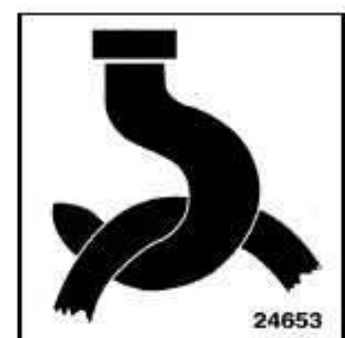

#### Fork Safety - 426641

(Mast equipped models). Location: on the front and back side of the mast's outer rails, at eye level (4 required)



at eye level (if required).

Instructs personnel not to travel beneath or upon the lift truck forks.



### Pinch Point, Large, 2.5 x 4.5 in. - 426643

### Pinch Point, Small, 1.5 x 2.75 in. - 426642

(Mast equipped models). Location: on the front and rear sides of the mast cross bracing.

Keep fingers away from the mast crossbracing.

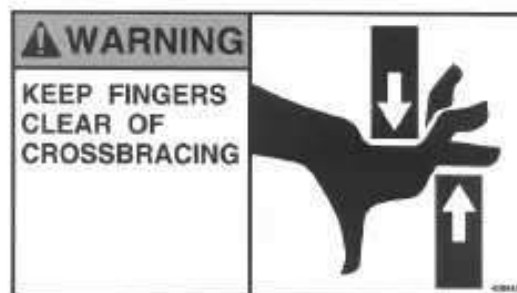

### HAND THROTTLE DANGER - 804784

(Boom equipped models, option). Location: Near the hand throttle mechanism.

Reminder to operator; set parking brake before operating hand throttle. Disengage hand throttle before leaving the forklift.



## CONTENTS

### SAFETY DECALS

#### Acid in Battery - 801014

Location: in or near the battery storage compartment.

Addresses battery hazards.



#### Jump Start Battery - 801015

Location: in or near the battery storage compartment.

Jump start instructions.

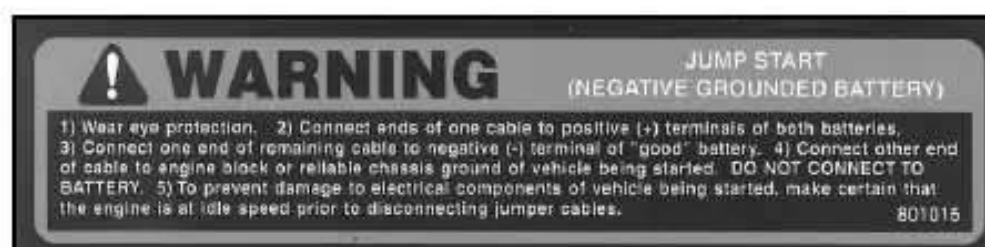

#### Attachment Plate - 425995

Location: on the optional removeable forklift attachment.



Important manufacturer information about the attachment. Record this information for use when contacting the manufacturer for parts and service.

YEAR OF MANUFACTURE
COUNTRY OF MANUFACTURE
UNLADEN WEIGHT (LBS.)
CAPACITY (LBS.)
HORIZONTAL CENTER OF GRAVITY (IN.)
OPERATING PRESSURE (PSI)
<b>WARNING</b>
This attachment affects the capacity of the lift truck.
Check the operator service manual or load chart for net capacity with this attachment.
If the load chart is not available, contact the factory.

**Overhead Guard Data Plate - B6109**

Location: attached to the overhead guard.

Overhead guard conformity.

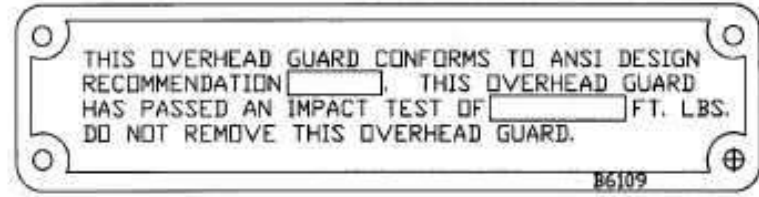

**Forklift Data Plate - 496550**

(Boom equipped models)

**Forklift Data Plate - 496538**

(Mast equipped models)

Location: within the operator's compartment.

Important forklift truck identification. Record this information for use when contacting the manufacturer for parts and service.

496550

496538

**MANITOU**  
 MANITOU NORTH AMERICA, INC.  
 6401 IMPERIAL DR.  
 WACO, TX. 76712  
 800-433-3304  
 www.manitou-na.com

TRUCK MODEL [ ]  
 SERIAL NUMBER [ ]  
 UNLADEN WEIGHT [ ] LBS.  
 YEAR OF MFG. [ ]

TIRE PRESSURE: FRONT [ ] PSI  
 TIRE PRESSURE: REAR [ ] PSI

FOR CAPACITIES, REFER TO THE APPROPRIATE LIFT CHART OR CONTACT THE FACTORY. AS RELEASED FROM THE FACTORY, THIS TRUCK CONFORMS TO DESIGN STANDARDS ANSI/ASME B56.6

MANUFACTURED IN [ ]

**MANITOU**  
 MANITOU NORTH AMERICA, INC.  
 6401 IMPERIAL DR.  
 WACO, TX. 76712  
 800-433-3304

TRUCK MODEL [ ] S.N. [ ]  
 MAST MODEL [ ]  
 MAST S.N. [ ]  
 ATTACHMENTS [ ] S.N. [ ]  
 UNLADEN WEIGHT [ ] LBS.  
 YEAR OF MFG. [ ]

A [ ] INCHES  
 C [ ] INCHES

MAX CAPACITY [ ] LBS.  
 UP TO (B) [ ] INCHES  
 MAX CAPACITY [ ] LBS.  
 AT MPH (B) [ ] INCHES

TIRE PRESSURE: FRONT [ ] PSI  
 TIRE PRESSURE: REAR [ ] PSI

CAPACITY WITH ATTACHMENTS LISTED ABOVE ARE WITH FORKLIGHTS VERTICAL. FOR OTHER CAPACITIES CONTACT THE FACTORY. AS RELEASED FROM THE FACTORY, THIS TRUCK CONFORMS TO DESIGN STANDARDS ANSI/ASME B56.6

MANUFACTURED IN [ ]

# 1 - OPERATING AND SAFETY INSTRUCTIONS

**1 - 1**

**CONTENTS**

## CONTENTS

## TABLE OF CONTENTS

<b><i>INSTRUCTIONS TO THE COMPANY MANAGER</i></b>	<b>1 - 4</b>
<b>THE OPERATOR</b>	<b>1 - 4</b>
<b>THE LIFT TRUCK</b>	<b>1 - 4</b>
A - THE LIFT TRUCK'S SUITABILITY FOR THE JOB	1 - 4
B - ADAPTATION OF THE LIFT TRUCK TO STANDARD ENVIRONMENTAL CONDITIONS	1 - 4
C - MODIFICATION OF THE LIFT TRUCK	1 - 4
<b>THE INSTRUCTIONS</b>	<b>1 - 5</b>
<b>THE MAINTENANCE</b>	<b>1 - 5</b>
<b><i>INSTRUCTIONS FOR THE OPERATOR</i></b>	<b>1 - 6</b>
<b>PREAMBLE</b>	<b>1 - 6</b>
<b>GENERAL INSTRUCTIONS</b>	<b>1 - 6</b>
A - OPERATOR'S MANUAL	1 - 6
B - AUTHORIZATION FOR USE	1 - 6
C - MAINTENANCE	1 - 6
D - MODIFICATION OF THE LIFT TRUCK	1 - 6
E - LIFTING PEOPLE	1 - 7
<b>OPERATING INSTRUCTIONS UNLADEN AND LADEN</b>	<b>1 - 8</b>
A - BEFORE STARTING THE LIFT TRUCK	1 - 8
B - DRIVER'S OPERATING INSTRUCTIONS	1 - 8



C - ENVIRONMENT	1 - 9
D - VISIBILITY	1 - 9
E - STARTING THE LIFT TRUCK	1 - 10
F - DRIVING THE LIFT TRUCK	1 - 10
G - STOPPING THE LIFT TRUCK	1 - 11
H - DRIVING THE LIFT TRUCK ON THE PUBLIC HIGHWAY	1 - 12
<b>INSTRUCTIONS FOR HANDLING A LOAD</b>	<b>1 - 14</b>
A - CHOICE OF ATTACHMENTS	1 - 14
B - MASS OF LOAD AND CENTER OF GRAVITY	1 - 14
C - N/A	1 - 14
D - TRANSVERSE ATTITUDE OF THE LIFT TRUCK	1 - 15
E - TAKING UP A LOAD ON THE GROUND	1 - 16
F - TAKING UP AND LAYING A HIGH LOAD ON TIRES	1 - 17
<b>INSTRUCTIONS FOR USE AS A LOADER</b>	<b>1 - 18</b>
A - LOADING	1 - 18
B - FILLING	1 - 18

## ***MAINTENANCE INSTRUCTIONS OF THE LIFT TRUCK***

**1 - 20**

<b>GENERAL INSTRUCTIONS</b>	<b>1 - 20</b>
<b>MAINTENANCE</b>	<b>1 - 20</b>
<b>LUBRICANT AND FUEL LEVELS</b>	<b>1 - 20</b>
<b>HYDRAULIC</b>	<b>1 - 20</b>
<b>ELECTRICITY</b>	<b>1 - 20</b>
<b>WELDING</b>	<b>1 - 21</b>
<b>WASHING THE LIFT TRUCK</b>	<b>1 - 21</b>

## ***IF THE LIFT TRUCK IS NOT TO BE USED FOR A LONG TIME***

**1 - 22**

<b>INTRODUCTION</b>	<b>1 - 22</b>
<b>PREPARING THE LIFT TRUCK</b>	<b>1 - 22</b>
<b>PROTECTING THE I.C. ENGINE</b>	<b>1 - 22</b>
<b>PROTECTING THE LIFT TRUCK</b>	<b>1 - 22</b>
<b>BRINGING THE LIFT TRUCK BACK INTO SERVICE</b>	<b>1 - 23</b>

## ***INSTRUCTIONS TO THE COMPANY MANAGER***

### ***THE OPERATOR***

- Only qualified, authorized personnel may use the lift truck. This authorization is given in writing by the appropriate person in the establishment with respect to the use of lift trucks and must be carried permanently by the operator.

### ***WARNING***

*On the basis of experience, there are a number of possible situations in which operating the lift truck is prohibited. Such foreseeable abnormal uses, the main ones being listed below, are strictly forbidden.*

- *The foreseeable abnormal behavior of neglect, but not intending to put the machinery to any improper use.*
- *The reflex reactions of a person in the event of a malfunction, incident, fault, etc. during operation of the lift truck.*
- *Behavior resulting from application of the "principle of least action" when performing a task.*
- *For certain machines, the foreseeable behavior of such persons as unauthorized: apprentices, teenagers, handicapped persons and trainees tempted to drive a lift truck. Truck drivers tempted to operate a truck to win a bet, in competition or for their own personal experience.*

*The person in charge of the equipment must take these criteria into account when assessing whether or not a person will make a suitable driver.*

### ***THE LIFT TRUCK***

- MANITOU has ensured that this lift truck is suitable for use under the standard operating conditions defined in this operator's manual, with a **STATIC** test coefficient of **1.33** and a **DYNAMIC** test coefficient of **1**, as specified in harmonized norm **EN 1459** for variable range trucks.
- Before commissioning, the company manager must make sure that the lift truck is appropriate for the work to be done, and perform certain tests (in accordance with current legislation).

### **B - ADAPTATION OF THE LIFT TRUCK TO STANDARD ENVIRONMENTAL CONDITIONS**

- In addition to series equipment mounted on your lift truck, many options are available, such as : road lighting, stop lights, flashing light, reverse lights, reverse buzzer alarm, front light, rear light, light at the boom head, etc.
- The operator must take into account the operating conditions to define the lift truck's signalling and lighting equipment. Contact your dealer.
- Take into account climatic and atmospheric conditions of the site of utilization.
  - . Protection against frost (see : 3 - MAINTENANCE : LUBRICANTS AND FUEL).
  - . Adaptation of lubricants (ask your dealer for information).
  - . I.C. engine filtration (see : 3 - MAINTENANCE : FILTERS CARTRIDGES AND BELTS).

<b>IMPORTANT</b>	<i>For operation under average climatic conditions, i.e. between -15 °C and + 35 °C (5° to 95°F), correct levels of lubricants in all the circuits are provided in production. For operation under more severe climatic conditions, before starting up, it is necessary to drain all the circuits, then add the correct levels of lubricants properly suited to the relevant ambient temperatures. It is the same for the cooling fluid (Contact your dealer for information, if necessary).</i>
------------------	--

- A lift truck operating in an area without fire extinguishing equipment must be equipped with an individual extinguisher. There are solutions, consult your dealer.

 <b>WARNING</b>	<i>Your lift truck is designed for outdoor use under normal atmospheric conditions and indoor use in suitably aerated and ventilated premises. It is prohibited to use the lift truck in areas where there is a risk of fire or which are potentially explosive (i.e. refineries, fuel or gas depots, stores of inflammable products...). For use in these areas, specific equipment is available (ask your dealer for information).</i>
--	--

### **C - MODIFICATION OF THE LIFT TRUCK**

- For your safety and that of others, you must not change the structure and settings of the various components used in your lift truck (hydraulic pressure, calibrating limiters, I.C. engine speed, addition of extra equipment, addition of counterweight, unapproved attachments, alarm systems, etc.) yourself. In this event, the manufacturer cannot be held responsible.

## CONTENTS

### ***THE INSTRUCTIONS***

---

- The operator's manual must always be in good condition and kept in the place provided on the lift truck and in the language used by the operator.
- The operator's manual and any plates or decals which are no longer legible or are damaged, must be replaced immediately.

### ***THE MAINTENANCE***

---

- Maintenance or repairs other than those detailed in part : 3 - MAINTENANCE must be carried out by qualified personnel (consult your dealer) and under the necessary safety conditions to maintain the health of the operator and any third party.

 <b>WARNING</b>	<i>Your lift truck must be inspected periodically to ensure that it remains in compliance. The frequency of this inspection is defined by current legislation in the country in which the lift truck is used.</i>
--	---

**CONTENTS**

## **INSTRUCTIONS FOR THE OPERATOR**

### ***PREAMBLE***

---



*The risk of accident while operating, servicing or repairing your lift truck can be reduced if you follow the safety instructions and safety measures detailed in this manual. Failure to respect the safety and operating instructions, or the instructions for repairing or servicing your lift truck can lead to serious injury or fatal accident.*

- Only the operations and maneuvers described in these operator's manual may be performed. The manufacturer cannot predict all possible risky situations. Consequently, the safety instructions given in the operator's manual and on the lift truck itself are not all inclusive.
- At any time, as an operator, you must envisage, within reason, the possible risk to yourself, to others or to the lift truck itself when you use it.

### ***GENERAL INSTRUCTIONS***

---

#### **A - OPERATOR'S MANUAL**

- Read the operator's manual carefully.
- The operator's manual must always be in good condition and in the place provided for it on the lift truck.
- You must report any plates and decals which are no longer legible or which are damaged.

#### **B - AUTHORIZATION FOR USE**

- Only qualified, authorized personnel may use the lift truck. This authorization is given in writing by the appropriate person in the company, in charge of using the lift truck, and must be permanently carried by the operator.

- The operator is not competent to authorize driving the lift truck by another person.

### **C - MAINTENANCE**

- The operator must immediately advise his superior if his lift truck is not in good working order or does not comply with the safety notice.
- The operator is prohibited from carrying out any repairs or adjustments himself, unless he has been trained for this purpose. He must keep the lift truck properly cleaned if this is among his responsibilities.
- The operator must carry out daily maintenance (see : 3 - MAINTENANCE : A - DAILY OR EVERY 10 HOURS SERVICE).
- The operator must ensure tires are adapted to the nature of the ground (see area of the contact surface of the tires in the chapter : 2 - DESCRIPTION : CHARACTERISTICS). There are optional solutions, consult your dealer.
  - . SAND tires.
  - . LAND tires.
  - . Snow chains.



### **DANGER**

*Do not operate the lift truck if the tires are incorrectly inflated, damaged or excessively worn, Bad tires can put your safety or that of others at risk, or cause damage to the lift truck. The installation of foam inflated tires is prohibited and is not guaranteed by the manufacturer (prior authorization is required).*

### **D - MODIFICATION OF THE LIFT TRUCK**

- For your safety and that of others, you must not change the structure and settings of the various components used in your lift truck (hydraulic pressure, calibrating limiters, I.C. engine speed, addition of extra equipment, addition of counterweight, unapproved attachments, alarm systems, etc.) yourself. In this event, the manufacturer cannot be held responsible.

### **E - LIFTING PEOPLE**

- The use of working equipment and load lifting attachments to lift people is strictly forbidden.

**CONTENTS**

***OPERATING INSTRUCTIONS UNLADEN AND LADEN***

---

**A - BEFORE STARTING THE LIFT TRUCK**

- Carry out daily maintenance (see : 3 - MAINTENANCE : A - DAILY OR EVERY 10 HOURS SERVICE).
- Make sure the lights, indicators and windscreen wipers are working properly.
- Make sure the rear view mirrors are in good condition, clean and properly adjusted.
- Make sure the horn and backup alarm work properly.

**B - DRIVER'S OPERATING INSTRUCTIONS**

- Whatever his experience, the operator is advised to familiarize himself with the position and operation of all the controls and instruments before operating the lift truck.
- Wear clothes suited for driving the lift truck, avoid loose clothes.
- Make sure you have the appropriate protective equipment for the job to be done.
- Prolonged exposure to high noise levels may cause hearing problems. It is recommended to wear ear muffs to protect against excessive noise.
- Always face the lift truck when getting into and leaving the driving seat and use the handle(s) provided for this purpose. Do not jump out of the seat to get down.
- Always pay attention when using the lift truck. Do not listen to the radio or music using headphones or earphones.
- Never operate the lift truck when hands or feet are wet or soiled with greasy substances.
- For increased comfort, adjust the seat to your requirements and adopt the correct position in the driver's cab.



**CAUTION**

*Under no circumstances should the seat be adjusted while the lift truck is moving.*

- The operator must always be in his normal position in the driver's cab. It is prohibited to have arms or legs, or generally any part of the body, protruding from the driver's cab. <https://www.forkliftpdfmanuals.com/>
- The safety belt must be worn and adjusted to the operator's size.

- The control levers must never in any event be used for any other than their intended purposes (e.g. climbing onto or down from the lift truck, etc.).
- If the control components are fitted with a forced operation (lever lock) device, it is forbidden to leave the cab without first putting these controls in neutral.
- It is prohibited to carry passengers either on the lift truck or in the cab.

1 - 8

## CONTENTS

### C - ENVIRONMENT

- Comply with site safety regulations.
- If you have to use the lift truck in a dark area or at night, make sure it is equipped with working lights.
- During handling operations, make sure that no one is in the way of the lift truck and its load.
- Do not allow anybody to come near the working area of the lift truck or pass beneath an elevated load.
- When using the lift truck on a transverse slope, before lifting the boom, follow the instructions given in the paragraph : INSTRUCTIONS FOR HANDLING A LOAD : D - TRANSVERSE ATTITUDE OF THE LIFT TRUCK.
- Travelling on a longitudinal slope :
  - Drive and brake gently.

- Moving without load : Forks or attachment facing downhill.



- Moving with load : Forks or attachment facing uphill.





- Take into account the lift truck's dimensions and its load before trying to negotiate a narrow or low passageway.
- Never move onto a loading platform without having first checked :
  - That it is suitably positioned and made fast.
  - That the unit to which it is connected (wagon, truck, etc.) will not shift.
  - That this platform is prescribed for the total weight of the lift truck to be loaded.
  - That this platform is prescribed for the size of the lift truck.
- Never move onto a foot bridge, floor or freight lift, without being certain that they are prescribed for the weight and size of the lift truck to be loaded and without having checked that they are in sound working order.
- Be careful in the area of loading bays, trenches, scaffolding, soft land and manholes.
- Make sure the ground is stable and firm under the wheels and/or stabilizers before lifting or removing the load. If necessary, add sufficient wedging under the stabilizers.

- Make sure that the scaffolding, loading platform, pilings or ground is capable of bearing the load.
- Never stack loads on uneven ground, they may tip over.

 <b>WARNING</b>	<p><i>If the load or the attachment must remain above a structure for a period of time, there is the risk that it will settle upon the structure as the hydraulic oil in the cylinders cools.</i></p> <p><i>To eliminate this risk :</i></p> <ul style="list-style-type: none"> <li>- Regularly check the distance between the load or the attachment and the structure and readjust as necessary.</li> <li>- If possible use the lift truck at an oil temperature as close as possible to ambient temperature.</li> </ul>
--	--

- In the case of work near aerial lines, ensure that the safety distance is sufficient between the working area of the lift truck and the aerial line.

 <b>DANGER</b>	<p><i>You must consult your local electrical agency. You could be electrocuted or seriously injured if you operate or park the lift truck too close to power lines.</i></p>
---	---

 <b>DANGER</b>	<p><i>During high winds do not attempt moving loads that may catch the wind or cause the fork lift to be unstable.</i></p>
---	--

## D - VISIBILITY

- The safety of personnel within the lift truck's radius of operation as well as that of the lift truck and its operator, depends on the operator having good visibility of the environment immediately around the lift truck, under all circumstances at all times.
- This lift truck was designed to provide the operator with good visibility (direct or indirect via rear-view mirrors) of the immediate environment during movement with the lift truck empty and boom in transport position.
- If the volume of the load limits visibility ahead, particular precautions must be taken :
  - move in reverse ;
  - adjust the site layout ;
  - be assisted by someone (outside the area of operations of the lift truck) who can direct movements, making sure that this person is always in view.
  - always avoid maneuvering too far in reverse.
- With certain specific attachments, lift truck moving operations may need the boom to be in high position. In this case, visibility on the right is limited and particular precautions must be taken :
  - adjust the site layout ;
  - be assisted by someone (outside the area of operations of the lift truck) who can direct movements.
- In any situation where visibility of the route is inadequate, obtain the help of someone (outside the area of operations of the lift truck) to direct movements, making sure that this person is always in view.
- Maintain all components used for visibility clean, well-adjusted, and in good working order : windscreen and windows, windscreen wipers and washers, road and work lights, rear-view mirrors.

## CONTENTS

## E - STARTING THE LIFT TRUCK

### SAFETY NOTICE

 <b>WARNING</b>	<p><i>The lift truck must be started or maneuvered only when the operator is sitting in the driver's cab, his seat belt fastened and properly adjusted.</i></p>
--	---

- Never try to start the lift truck by pushing or towing it. Such operation may cause severe damage to the transmission. If necessary, to tow the lift truck in an emergency, the transmission must be placed in the neutral position (see : 3 - MAINTENANCE : G - OCCASIONAL MAINTENANCE).
- If using an emergency battery for start-up, use a battery with the same characteristics and respect battery polarity when connecting it. Connect at first the positive terminals before the negative terminals.

 <b>WARNING</b>	<p><i>Failure to respect polarity between batteries can cause serious damage to the electrical circuit. The electrolyte in the battery may produce an explosive gas. Avoid flames and generation of sparks close to the batteries. Never disconnect a battery while it is charging.</i></p>
--	---

### INSTRUCTIONS

- Check the closing and locking of the hood(s).
- Make sure that the forward/reverse lever is in neutral.
- Turn the ignition key to the position I to activate the electrical system.
- Make sure the signal lights on the instrument control panel and fuel level indicators are working properly (see : 2 - DESCRIPTION : INSTRUMENTS AND CONTROLS).
- Turn the ignition key to position II to preheat for 5 seconds and turn the ignition key fully : the I.C. engine should then start. Release the ignition key and let the I.C. engine run at idle.
- Do not engage the starter motor for more than 15 seconds and carry out the preheating for 5 seconds between unsuccessful attempts.
- Make sure all the signal lights on the control instrument panel are off.
- Check all control instruments when the I.C. engine is warm and at regular intervals during use, so as to quickly detect any pro-

Check all control instruments when the I.C. engine is warm and at regular intervals during use, so as to quickly detect any problems and to be able to correct them without any delay.

- If an instrument does not show the correct display, stop the I.C. engine and immediately carry out the necessary operations.

## F - DRIVING THE LIFT TRUCK

### SAFETY NOTICE

 <b>DANGER</b>	<p>Operators' attention is drawn to the risks involved in using the lift truck, in particular :</p> <ul style="list-style-type: none"><li>- Risk of losing control.</li><li>- Risk of losing lateral and frontal stability of the lift truck.</li></ul> <p>The operator must remain in control of the lift truck. In the event of the lift truck overturning, do not try to leave the cab during the incident. <b>YOUR BEST PROTECTION IS TO STAY FASTENED IN THE CAB.</b></p>
--	--

- Observe the company's traffic regulations or, by default, the public highway code.
- Do not carry out operations which exceed the capacities of your lift truck or attachments.
- Always drive the lift truck with the forks or attachment to the transport position, i.e. at 12 in. from the ground, the boom retracted and the carriage sloping backwards.
- Only carry loads which are balanced and properly anchored to avoid any risk of a load falling off.
- Ensure that pallets, cases, etc, are in good order and suitable for the load to be lifted.
- Familiarize yourself with the lift truck on the terrain where it will be used.
- Ensure that the service brakes are working properly.
- The loaded lift truck must not travel at speeds in excess of 7 mph.
- Drive smoothly at an appropriate speed for the operating conditions (land configuration, load on the lift truck).
- Do not use the hydraulic boom controls when the lift truck is moving.
- Do not maneuver the lift truck with the boom in the raised position unless under exceptional circumstances and then with extreme caution, at very low speed and using gentle braking. Ensure that visibility is adequate.
- Take turns slowly.
- In all circumstances make sure you are in control of your speed.
- On damp, slippery or uneven terrain, drive slowly.
- Brake gently, never abruptly.
- Only use the lift truck's forward/reverse lever from a stationary position and never do so abruptly.
- Do not drive with your foot on the brake pedal.
- Always remember that hydrostatic type steering is extremely sensitive to movement of the steering wheel, so turn it gently and not abruptly.
- Never leave the I.C. engine on when the lift truck is unattended.
- Do not leave the cab when the lift truck has a raised load.
- Look where you are going and always make sure you have good visibility along the route.

## CONTENTS

- Use the rear-view mirrors frequently.
- Drive around obstacles.
- Never drive on the edge of a ditch or steep slope.
- It is dangerous to use two lift trucks simultaneously to handle heavy or voluminous loads, since this operation requires particular precautions to be taken. It must only be used exceptionally and after risk analysis.
- The ignition switch has an emergency stop mechanism in case of an operating anomaly occurring in the case of lift trucks not fitted with a punch-operated cut-out.

### INSTRUCTIONS

- Always drive the lift truck with the forks or attachment to the transport position, i.e. at 12 in. from the ground, the boom retracted and the carriage sloping backwards.
- For lift trucks with gearboxes, use the recommended gear (see : 2 - DESCRIPTION : INSTRUMENTS AND CONTROLS).
- Select the steering mode appropriate for its use and/or working conditions (see : 2 - DESCRIPTION : INSTRUMENTS AND CONTROLS) (as model of lift truck).
- Release the parking brake.
- Shift the forward/reverse lever to the selected direction of travel and accelerate gradually until the lift truck moves off.

## G - STOPPING THE LIFT TRUCK

### SAFETY NOTICE

- Never leave the ignition key in the lift truck during the operator's absence.
- When the lift truck is stationary, or if the operator has to leave his cab (even for a moment), place the forks or attachment on the ground, apply the parking brake and put the forward/reverse lever in neutral.
- Make sure that the lift truck is not stopped in any position that will interfere with the traffic flow and at least 6 ft. from the track of a railway.
- In the event of prolonged parking on a site, protect the lift truck from bad weather, particularly from frost (check the level of anti-freeze), close and lock all the lift truck accessories.



## INSTRUCTIONS

- Park the lift truck on flat ground or on an incline lower than 15 %.
- Place the forward/reverse lever in neutral.
- Apply the parking brake.
- For lift trucks with gearboxes, place the gear lever in neutral.
- Retract entirely the boom.
- Lower the forks or attachment to rest on the ground.
- When using an attachment with a grab or jaws, or a bucket with hydraulic opening, close the attachment fully.
- Before stopping the lift truck after a long working period, allow the I.C. engine to idle for a few moments, to allow the coolant liquid and oil to lower the temperature of the I.C. engine and transmission. Do not forget this precaution, in the event of frequent stops or warm stalling of the I.C. engine, or else the temperature of certain parts will rise significantly due to the stopping of the cooling system, with the risk of badly damaging such parts.
- Stop the I.C. engine with the ignition switch.
- Remove the ignition key.
- Lock all the accesses to the lift truck (doors, windows, cowls...).

## CONTENTS

### H - DRIVING THE LIFT TRUCK ON THE PUBLIC HIGHWAY

#### SAFETY INSTRUCTIONS

- Operators driving on the public highway must comply with current highway code legislation.
- The lift truck must comply with current road legislation. If necessary, there are optional solutions. Contact your dealer.

#### INSTRUCTIONS

- Make sure the revolving light is in place, switch it on and verify its operation.
- Check the good working order and cleanness of lights, indicators and windscreen wiper.
- Switch off the working headlights if the lift truck is fitted with them.
- Retract entirely the boom and put the attachment at 12 in. from the ground.
- For lift trucks with gearboxes :

On the road, set off in 3rd gear and go into 4th (as per model of lift truck) when the conditions and state of the road allow. In hilly areas, set off in 2nd gear and go into 3rd when the conditions and state of the road allow.



*Do not allow the lift truck to coast in neutral (using either the forward/reverse lever, gear shift lever or transmission cut-off button). Coasting on a slope will lead to excessive speed which may make the lift truck uncontrollable (steering, brakes) and may cause serious mechanical damage.*

## CONTENTS

### DRIVING THE LIFT TRUCK WITH A FRONT-MOUNTED ATTACHMENT

- You must comply with current regulations in your country, covering the possibility of driving on the public highway with a front-mounted attachment on your lift truck.
- If road legislation in your country authorizes driving with a front-mounted attachment, you must at least :
  - Protect and flag any sharp and/or dangerous edges on the attachment (see : 4 - ADAPTABLE ATTACHMENTS IN OPTION ON THE RANGE : ATTACHMENT SHIELDS).
  - The attachment must not be loaded.
  - Make sure that the attachment does not mask the lighting range of the forward lights.
  - Make sure that current legislation in your country does not require other obligations.

### OPERATING THE LIFT TRUCK WITH A TRAILER

- For using a trailer, observe the regulations in force in your country (maximum travel speed, braking, maximum weight of trailer, etc.).
- Do not forget to connect the trailer's electrical equipment to that of the lift truck.
- The trailer's braking system must comply with current legislation.
- If pulling a trailer with assisted braking, the tractor lift truck must be equipped with a trailer braking mechanism. In this case, do not forget to connect the trailer braking equipment to the lift truck.
- The maximum vertical pull on the trailer hook must not exceed 3370 ft/lb.
- The authorized maximum train weight must not exceed the maximum weight authorized by the manufacturer (consult the manufacturer's plate on your lift truck).
- For lift trucks with gearboxes :  
When driving with a trailer, set off in 2nd gear and go into 3rd when the conditions and state of the road allow. Do not exceed 4th gear to avoid overheating the internal combustion engine and the transmission.

**IF NECESSARY, CONSULT YOUR DEALER.**

**CONTENTS**

**INSTRUCTIONS FOR HANDLING A LOAD**

**A - CHOICE OF ATTACHMENTS**

- Only attachments approved by MANITOU can be used on its lift trucks.
- Make sure the attachment is appropriate for the work to be done (see : 4 - ADAPTABLE ATTACHMENTS IN OPTION ON THE RANGE).
- Make sure the attachment is correctly installed and locked onto the lift truck carriage.
- Make sure that your lift truck attachments work properly.
- Comply with the load chart limits for the lift truck for the attachment used.
- Do not exceed the rated capacity of the attachment.
- Never lift a load in a sling without the attachment provided for the purpose. There are optional solutions ; contact your dealer.

**B - MASS OF LOAD AND CENTER OF GRAVITY**

- Before taking up a load, you must know its mass and its center of gravity.
- The load chart for your lift truck is valid for a load in which the longitudinal position of the center of gravity is 24 in. from the base of the forks (fig. B1). For a higher center of gravity, contact your dealer.
- For irregular loads, determine the transverse center of gravity before any movement (fig. B2) and set it in the longitudinal axis of the lift truck.

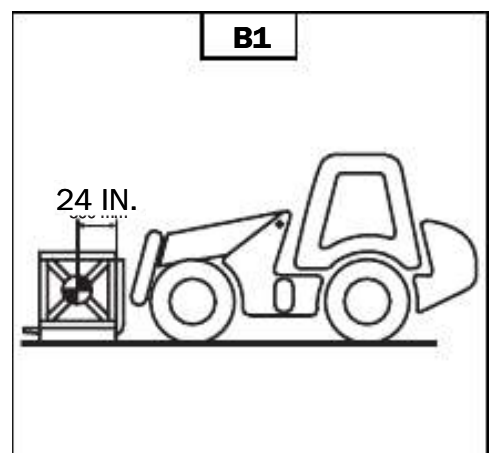

**CAUTION**

Do not attempt to move a load heavier than the effective capacity defined on the lift truck load chart.  
<https://www.forkliftpdfmanuals.com/>



## CAUTION

For loads with a moving center of gravity (i.e., liquids), take into account the variations of the center of gravity in order to determine the load to be handled (Consult your agent or dealer). Be vigilant and take extra care to limit these variations as much as possible.

B2

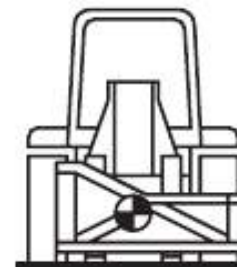

1 - 14

## CONTENTS

### D - TRANSVERSE (LEVEL) ATTITUDE OF THE LIFT TRUCK

(depending on the model of lift truck)

The transverse attitude is the transverse slope of the chassis with respect to the horizontal.

Raising the boom reduces the lift truck's lateral stability. The transverse attitude must be set with the boom in down position as follows :

### E - TAKING UP A LOAD ON THE GROUND

- Direct the lift truck perpendicular to the load, with the boom retracted and the forks in a horizontal position (fig. E1).
- Adjust the fork spread and centering in connection with the load (fig. E2) (optional solutions exist, consult your dealer).
- Never lift a load with a single fork.



## CAUTION

Beware of the risks of pinching or crushing fingers when manually adjusting the forks.

- Move the lift truck forward slowly (1) and bring the forks to rest in front of the load (fig. E3), if necessary, slightly lift the boom (2) while taking up the load.
- Bring the load into the transport position.
- Tilt the load far enough backwards to ensure stability (loss of load on braking or going downhill).

E1

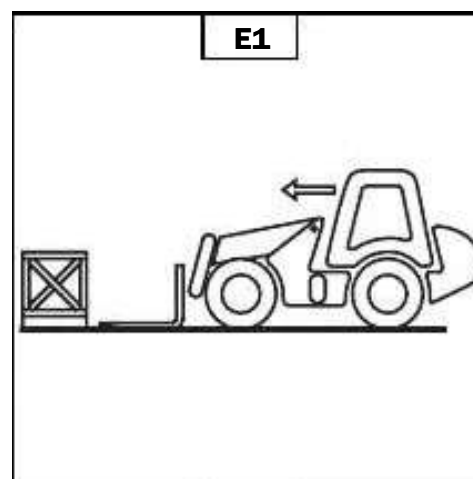

E2

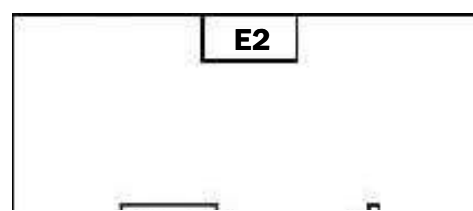

- Tilt the carriage (1) forwards and move the lift truck slowly forwards (2), to insert the fork under the load (fig. E4) (block the load if necessary).
- Continue to move the lift truck forwards (2) tilting the carriage (3) (fig. E4) backwards to position the load on the forks and check the load's longitudinal and lateral stability.

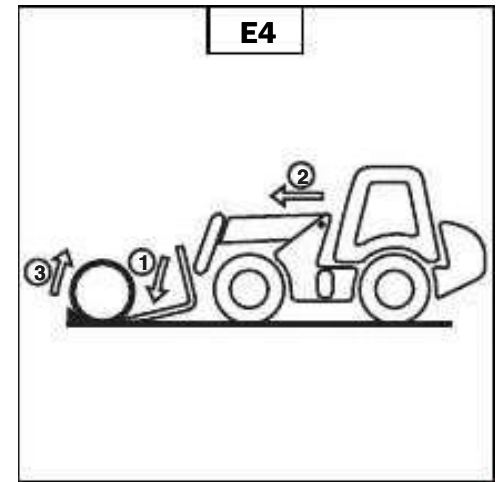
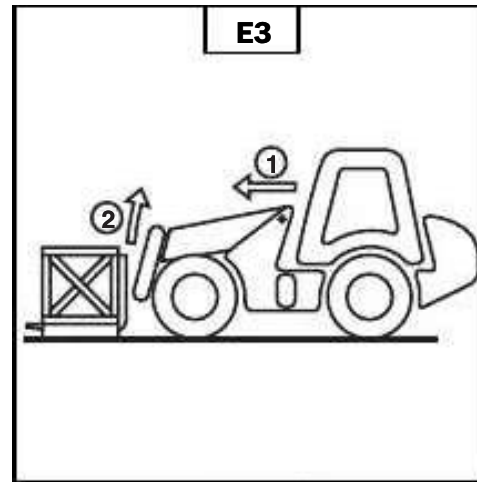
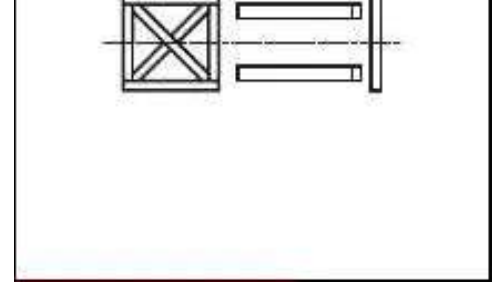

1 - 15

## CONTENTS

### F - TAKING UP AND LAYING A HIGH LOAD ON TIRES

#### WARNING

*Do not raise the boom until you have first checked the level attitude of the lift truck (see : INSTRUCTIONS FOR HANDLING A LOAD : D - TRANSVERSE ATTITUDE OF THE LIFT TRUCK).*

REMINDER : Make sure that the following operations can be performed with good visibility (see : OPERATIONS INSTRUCTIONS UNLADEN AND LADEN : D - VISIBILITY).

#### TAKING UP A HIGH LOAD ON TIRES

- Ensure that the forks will easily pass under the load.
- Lift and extend the boom (1) (2) until the forks are level with the load, moving the lift truck (3) forward if necessary (fig. F1), moving very slowly and carefully.
- Always think about keeping the distance necessary to fit the forks under the load, between the pile and the lift truck (fig. F1) and use the shortest possible length of boom.
- Bring the forks in front of the load by alternately extending and retracting the boom (1) or, if necessary, moving the lift truck forward (2) (fig. F2). Put the handbrake on and set the reverse gear to neutral.
- Slightly lift the load (1) and incline the carriage (2) backwards to stabilize the load (fig. F3).
- Tilt the load sufficiently backwards to ensure its stability.
- Watch the load, if it is overloaded, return the load to the place from which it was taken.
- If possible lower the load without shifting the lift truck. Lift the boom (1) to release the load, retract (2) and lower the boom (3) to bring the load into the transport position (fig. F4).
- If this is not possible, back up the lift truck (1), maneuvering very gently and carefully to

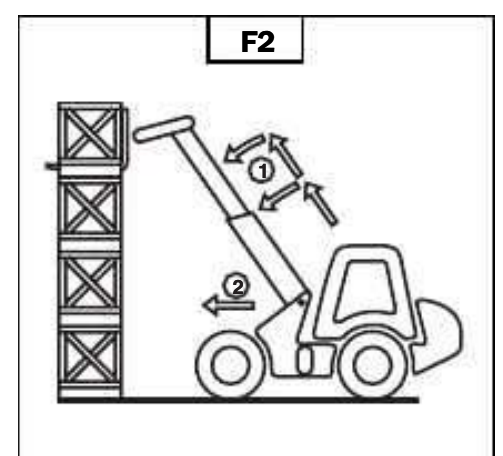
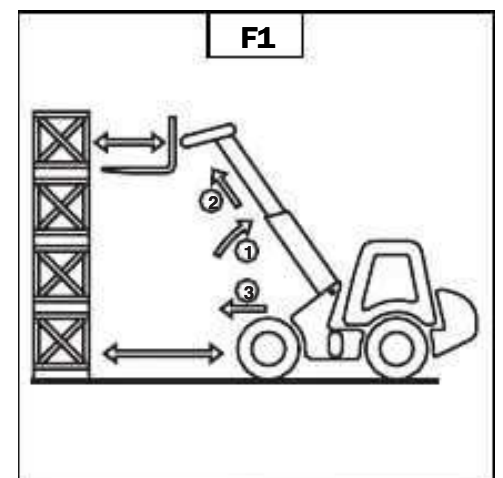

release the load. Retract (2) and lower the boom (3) to bring the load into the transport position (fig. F5).

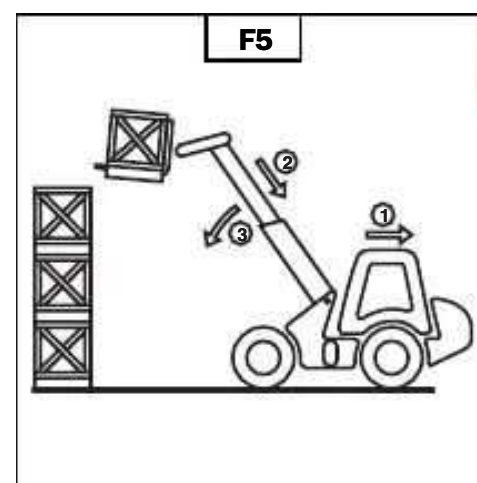
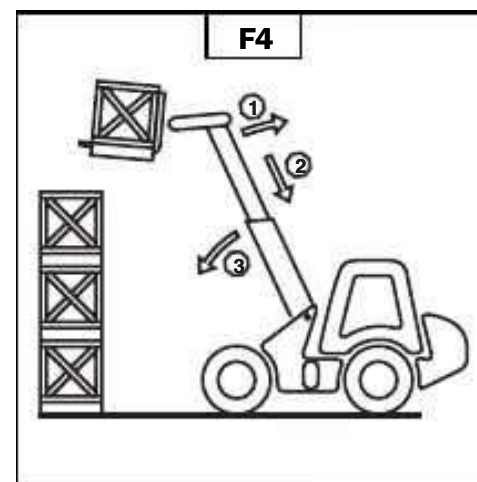
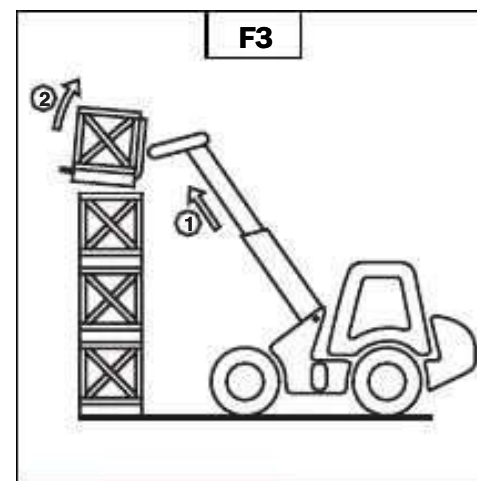

1 - 16

## CONTENTS

### LAYING A HIGH LOAD ON TIRES

- Approach with the load in the transport position in front of the pile (fig. F6).
- Put the handbrake on and set the reversing lever to neutral.
- Lift and extend the boom (1) (2) until the load is above the pile, while keeping an eye on the load. If necessary, move the lift truck (3) forward (fig. F7), driving very slowly and carefully.
- Place the load in a horizontal position and lay it down on the pile by lowering and retracting the boom (1) (2) in order to position the load correctly (fig. F8).
- If possible, release the fork by alternately retracting and raising the boom (1) (fig. F9). Then set the forks into transport position.
- If this is not possible, reverse the lift truck (1) very slowly and carefully to release the forks (fig. F10). Then set them into transport position.

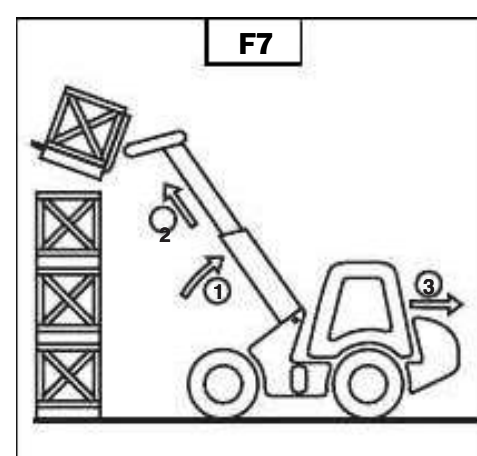
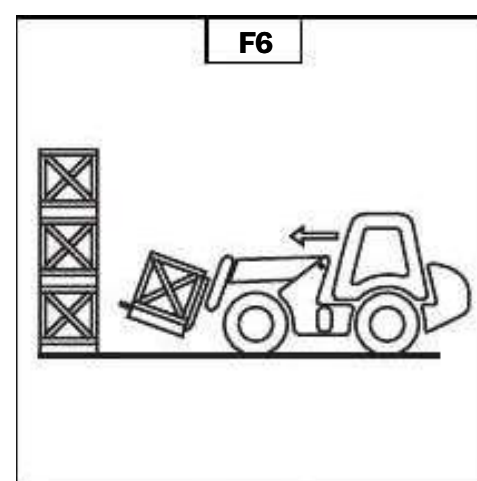

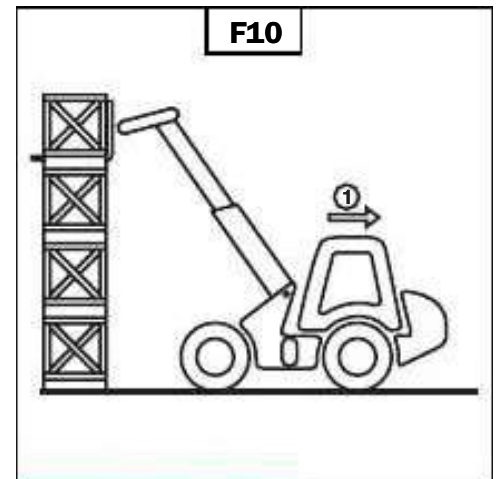
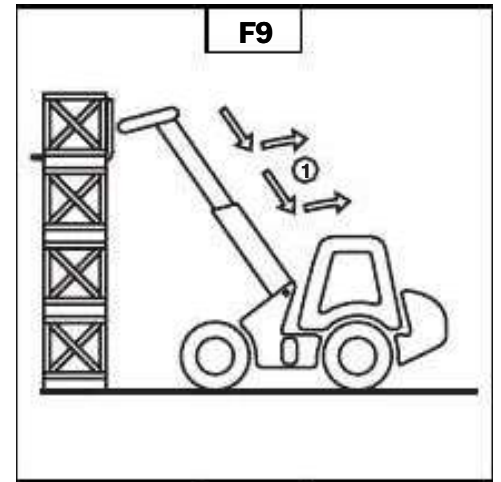
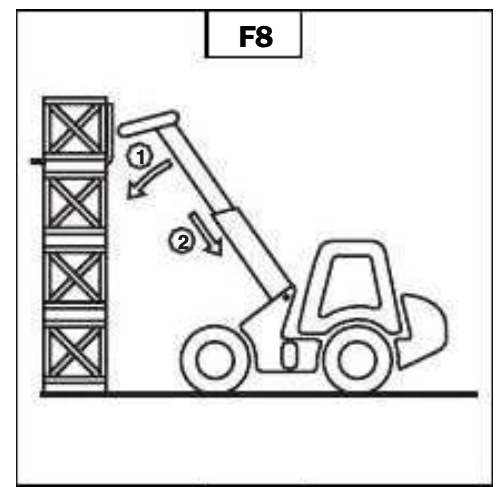

**CONTENTS**

**INSTRUCTIONS FOR USE AS A LOADER**

**A - LOADING**



**WARNING**

Do not raise the boom until you have first checked the level attitude of the lift truck (see : INSTRUCTIONS FOR HANDLING A LOAD : D - TRANSVERSE ATTITUDE OF THE LIFT TRUCK).

REMINDER: Make sure that the following operations can be performed with good visibility (see: **OPERATING INSTRUCTIONS UNLADEN AND LADEN: D – VISIBILITY**).

**FILLING THE BUCKET**

- Position the bottom of the bucket horizontally while scraping the ground (1) (fig. A1).
- Move forwards slowly (2) and raise the boom (3) while tilting the bucket backwards (3) (fig. A1) to improve filling and lifting.
- Reverse the forklift truck (1) very gently and carefully to release the bucket. Lower the boom (2) to transport position (fig.A2).

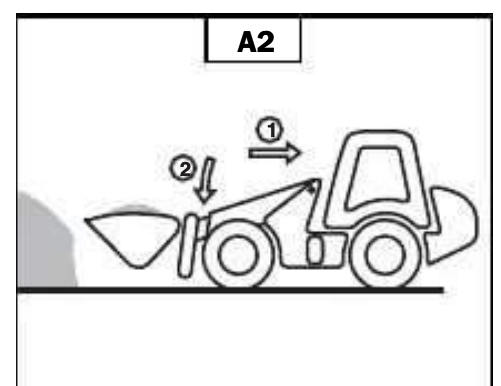
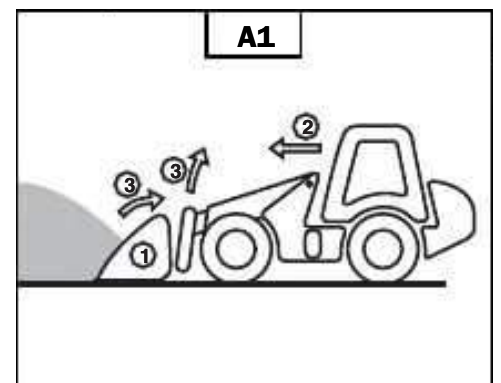

**WARNING**

Tilt the bucket backwards far enough to prevent any spillage and ensure its stability (loss of product on braking).

**LOADING A TRAILER**

- Approach the side of the trailer in transport position (fig. A3).
- Raise and extend the boom (1) (2) (fig. A4) until the bucket is over the trailer.

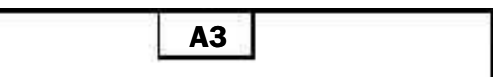

**A3**

keeping an eye on the load. Move the forklift truck (3) forwards very gently and carefully so that the load is tipped out into the center of the trailer. Put on the handbrake and set the reverse lever to neutral.

- Slowly tip out the product (4).
- Tilt the bucket backwards (1) (fig. A5) and reverse the forklift truck (2) gently and carefully.
- Retract (3) and lower the boom (4) into transport position (fig. A5).

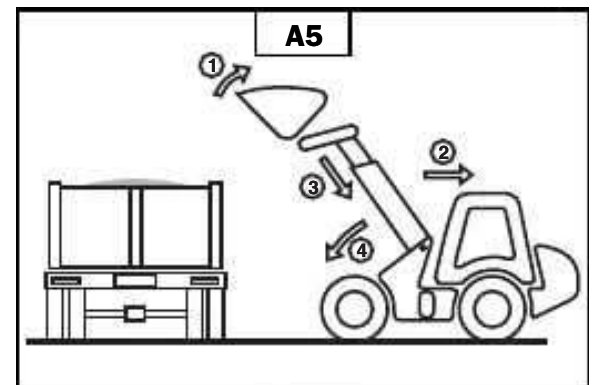
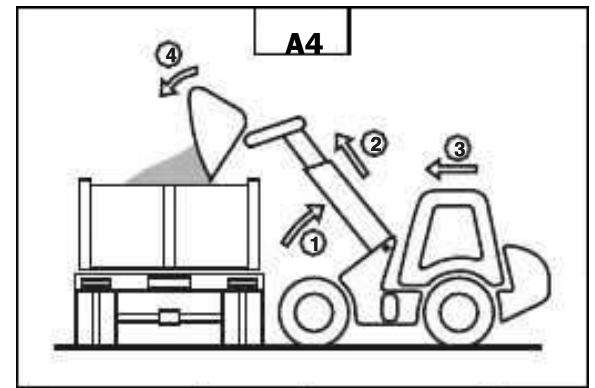
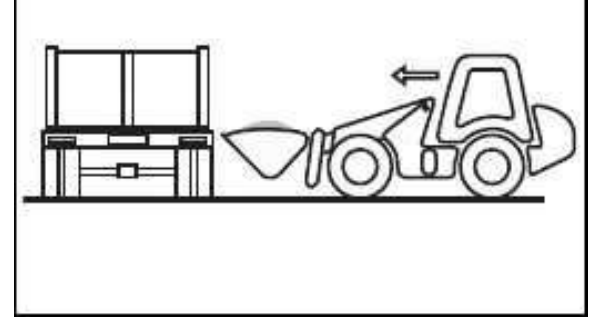

#### B - FILLING

- Position the bottom of the bucket horizontally while scraping the ground (1) (fig. B1).
- Move slowly forwards (2) once the bucket is full, it will act as a levelling blade.

	<b>WARNING</b>	<i>During movement, beware of trenches and land which has been recently dug and/ or filled in.</i>
---	----------------	--

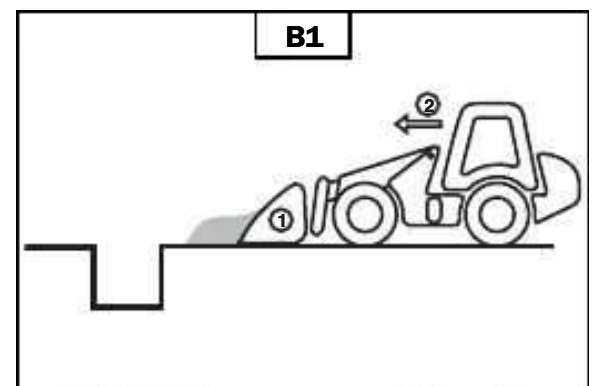



## **MAINTENANCE INSTRUCTIONS OF THE LIFT TRUCK**

### **GENERAL INSTRUCTIONS**

---

- Ensure the area is sufficiently ventilated before starting the lift truck.
- Wear clothes suitable for the maintenance of the lift truck, avoid wearing jewelry and loose clothes. Tie and protect your hair, if necessary.
- Stop the I.C. engine and remove the ignition key, when an intervention is necessary.
- Read the operator's manual carefully.
- Carry out all repairs immediately, even if the repairs concerned are minor.
- Repair all leaks immediately, even if the leak concerned is minor.
- Make sure that the disposal of process materials and of spare parts is carried out in total safety and in a ecological way.
- Beware of the risk of burning and splashing (exhaust, radiator, I.C. engine, etc.).

### **MAINTENANCE**

- Perform the periodic service (see : 3 - MAINTENANCE) to keep your lift truck in good working conditions. Failure to perform the periodic service may cancel the contractual guarantee.

### **LUBRICANT AND FUEL LEVELS**

---

<https://www.forkliftpdfmanuals.com/>

Use the recommended lubricants (never use contaminated lubricants)

- Use the recommended lubricants (never use contaminated lubricants).
- Do not fill the fuel tank when the I.C. engine is running.
- Only fill up the fuel tank in areas specified for this purpose.
- Do not fill the fuel tank to the maximum level.
- Do not smoke or approach the lift truck with a flame, when the fuel tank is open or is being filled.

## **HYDRAULIC**

---

- Any work on the load handling hydraulic circuit is forbidden except for the operations described in part : 3 - MAINTENANCE.
- Do not attempt to loosen unions, hoses or any hydraulic component with the circuit under pressure.

 <b>WARNING</b>	<i>BALANCING VALVE : For inspection, see : 3 – MAINTENANCE : D - EVERY 500 HOURS SERVICE. It is dangerous to change the setting or remove the balancing valves or safety valves which may be fitted to your lift truck cylinders. These operations must only be performed by approved personnel (consult your dealer).</i>
--	--

 <b>WARNING</b>	<i>The HYDRAULIC ACCUMULATORS which may be fitted on your lift truck, are under high pressure, it is dangerous to dismantle them. This operation must only be performed by approved personnel (consult your dealer).</i>
--	--

## **ELECTRICITY**

---

- Do not short-circuit the starter relay to start the IC engine. If the gear reverser is not in neutral and the parking brake is not engaged, the lift truck may suddenly start to move.
- Do not drop metallic items on the battery.
- Disconnect the battery before working on the electrical circuit.

## **WELDING**

---

- Disconnect the battery before any welding operations on the lift truck.
- When carrying out electric welding work on the lift truck, connect the negative cable from the equipment directly to the part being welded, so as to avoid high tension current passing through the alternator.
- Never carry out welding or work which gives off heat on an assembled tire. The heat would increase the pressure which could cause the tire to explode.
- If the lift truck is equipped with an electronic control unit, disconnect this before starting to weld, to avoid the risk of causing irreparable damage to electronic components.

## **WASHING THE LIFT TRUCK**

---

- Clean the lift truck or at least the area concerned before any intervention.
- Remember to close and lock all accesses to the lift truck (doors, windows, cowls...).
- During washing, avoid the articulations and electrical components and connections.
- If necessary, protect against penetration of water, steam or cleaning agents, components susceptible of being damaged, particularly electrical components and connections and the injection pump.
- Clean the lift truck of any fuel, oil or grease trace.

**FOR ANY INTERVENTION OTHER THAN REGULAR MAINTENANCE, CONSULT YOUR DEALER.**

## **IF THE LIFT TRUCK IS NOT TO BE USED FOR A LONG TIME**

### ***INTRODUCTION***

---

The following recommendations are intended to prevent the lift truck from being damaged when it is withdrawn from service for an extended period.

For these operations, we recommend the use of protective products.

Instructions for using the product are given on the packaging.

<b>IMPORTANT</b>	<i>It is recommended that your dealer perform the following procedures for lift truck storage and returning it to service.</i>
------------------	--

### ***PREPARING THE LIFT TRUCK***

---

- Clean the lift truck thoroughly.
- Check and repair any leakage of fuel, oil, water or air.
- Replace or repair any worn or damaged parts.
- Wash the painted surfaces of the lift truck in clear and cold water and wipe them.
- Touch up the paintwork if necessary.
- Shut down the lift truck (see : OPERATING INSTRUCTIONS UNLADEN AND LADEN).
- Make sure the boom cylinder rods are all in retracted position.
- Release the pressure in the hydraulic circuit.

## ***PROTECTING THE I.C. ENGINE***

---

- Fill the tank with fuel (see : 3 - MAINTENANCE : A - DAILY OR EVERY 10 HOURS SERVICE).
  - Empty and replace the cooling liquid (see : 3 - MAINTENANCE : F - EVERY 2000 HOURS SERVICE).
  - Leave the I.C. engine running at idling speed for a few minutes, then switch off.
  - Replace the I.C. engine oil and oil filter (see : 3 - MAINTENANCE : D - EVERY 500 HOURS SERVICE).
  - Add a protective product to the engine oil.
  - Run the I.C. engine for a short time so that the oil and cooling liquid circulate inside.
  - Disconnect the battery and store it in a safe place away from the cold, after charging it to a maximum.
  - Remove the injectors and spray a protective product into each cylinder for two seconds with the piston in low neutral position.
  - Turn the crankshaft once slowly and install the injectors (see I.C. engine REPAIR MANUAL).
  - Remove the intake hose from the manifold or turbocharger and spray a protective product into the manifold or turbocharger.
  - Cap the intake manifold or turbocharger hole with waterproof adhesive tape.
  - Remove the exhaust pipe and spray a protective product into the exhaust manifold or turbocharger.
  - Install the exhaust pipe and block the outlet with waterproof adhesive tape.
- NOTE : The spray time is noted on the product packaging and must be increased by 50 % for turbo engines.
- Open the filler plug, spray a protective product around the rocker arm shaft and install the filler plug.
  - Cap the fuel tank using waterproof adhesive tape.
  - Remove the drive belts and store them in a safe place.
  - Disconnect the engine cut-off solenoid on the injection pump and carefully insulate the connection.

## ***PROTECTING THE LIFT TRUCK***

---

- Set the lift truck on axle stands so that the tires are not in contact with the ground and release the handbrake.
  - Protect cylinder rods which will not be retracted, from corrosion.
  - Wrap the tires.
- NOTE : If the lift truck is to be stored outdoors, cover it with a waterproof tarpaulin.

## **CONTENTS**

### ***BRINGING THE LIFT TRUCK BACK INTO SERVICE***

---

- Remove the waterproof adhesive tape from all the holes.
- Install the intake hose.
- Install and reconnect the battery.
- Remove the protection from the cylinder rods.
- Perform the daily service (see : 3 - MAINTENANCE : A - DAILY OR EVERY 10 HOURS SERVICE).
- Put the handbrake on and remove the axle stands.
- Empty and replace the fuel and replace the fuel filter (see : 3 - MAINTENANCE : D - EVERY 500 HOURS SERVICE).
- Install and set the tension in the drive belts (see : 3 - MAINTENANCE : C - EVERY 250 HOURS SERVICE).
- Turn the I.C. engine using the starter, to allow the oil pressure to rise.
- Reconnect the engine cut-off solenoid.
- Lubricate the lift truck completely (see : 3 - MAINTENANCE : SERVICING SCHEDULE).



#### **WARNING**

*Insure the area is adequately ventilated before starting the lift truck.*

- Start up the lift truck, following the safety instructions and regulations (see : OPERATING INSTRUCTIONS UNLADEN AND LADEN).
- Run all the boom's hydraulic movements, concentrating on the ends of travel for each cylinder.

**1 - 23**

**CONTENTS**

1 - 24

CONTENTS

# **2 - DESCRIPTION**

**2 - 1**

**CONTENTS**

## **TABLE OF CONTENTS**

<b><i>IDENTIFICATION OF THE LIFT TRUCK</i></b>	<b>2 - 4</b>
<b><i>CHARACTERISTICS</i></b>	<b>2 - 6</b>
<b><i>DIMENSIONS AND LOAD CHART</i></b>	<b>2 - 10</b>
<b><i>INSTRUMENTS AND CONTROLS</i></b>	<b>2 - 12</b>
<b><i>TOWING PIN AND HOOK</i></b>	<b>2 - 28</b>
<b><i>DESCRIPTION AND USE OF ELECTRIC AND HYDRAULIC OPTIONS</i></b>	<b>2 - 30</b>



**CONTENTS**

**IDENTIFICATION OF THE LIFT TRUCK**

As our policy is to promote a constant improvement of our products, our range of telescopic lift trucks may undergo certain modifications without prior notice.

When you order parts, or when you require any technical information, always specify :

NOTE : For the owner's convenience, it is recommended that a note of these numbers is made in the spaces provided, at the time of the delivery of the lift truck.

**PLATE MANUFACTURER OF THE LIFT TRUCK (FIG. A)**

- Model \_\_\_\_\_
- Series \_\_\_\_\_
- Serial No. \_\_\_\_\_
- Chassis No. \_\_\_\_\_
- Year of manufacture \_\_\_\_\_

For any further technical information regarding your lift truck refer to chapter : 2 - DESCRIPTION : CHARACTERISTICS.

<https://www.forkliftpdfmanuals.com/>



**I.C. ENGINE (FIG. B)**

- I.C. engine No. \_\_\_\_\_

**TRANSMISSION (FIG. C)**

- Type \_\_\_\_\_  
- MANITOU reference \_\_\_\_\_  
- Serial No. \_\_\_\_\_

**FRONT AXLE (FIG. D)**

- Type \_\_\_\_\_  
- Serial No. \_\_\_\_\_  
- MANITOU reference \_\_\_\_\_

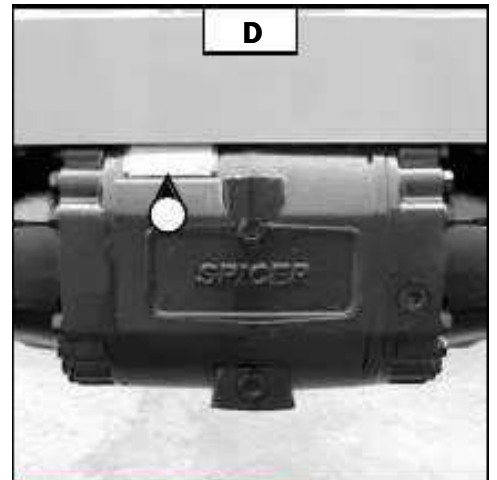
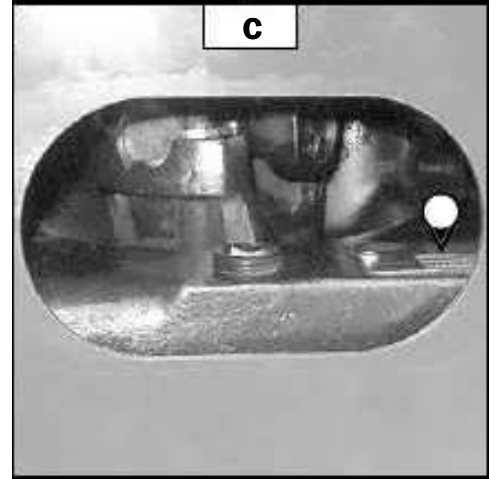
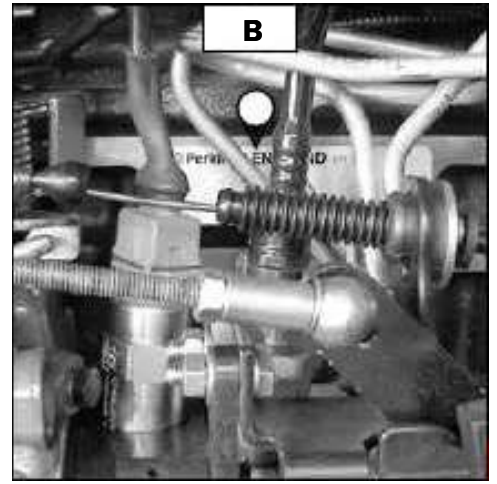

**CONTENTS**

**REAR AXLE (FIG. E)**

- Type \_\_\_\_\_  
- Serial No. \_\_\_\_\_  
- MANITOU reference \_\_\_\_\_

**CAB (FIG. F)**

- Type \_\_\_\_\_  
- Serial No. \_\_\_\_\_

**BOOM (FIG. G)**

- MANITOU reference \_\_\_\_\_  
- Date of manufacture \_\_\_\_\_

**PLATE MANUFACTURER OF THE ATTACHMENT (FIG. H)**

- Model \_\_\_\_\_

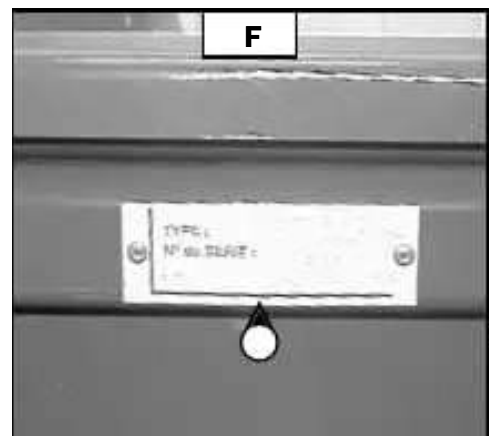
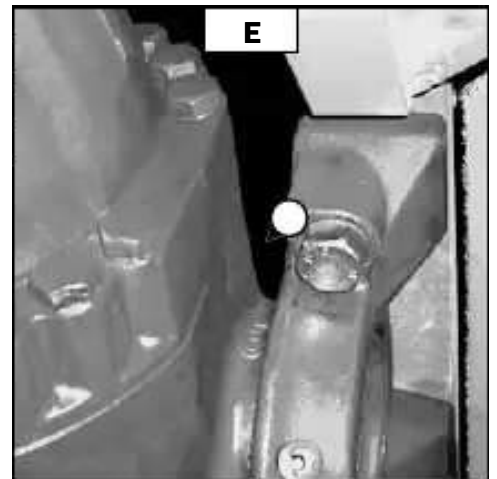

- Serial No.
- Year of manufacture

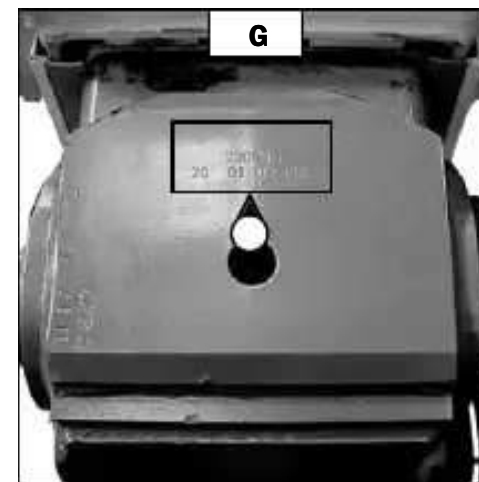
**CONTENTS**

**CHARACTERISTICS**

**I.C. ENGINE**

- Type	<b>MLA 628 -120 LSU POWERSHIFT Series 3-E2</b>	<b>PERKINS 1104C-44TA RJ81416</b>
- Number of cylinders		<b>1104C-44TA</b>
- Number of strokes		4 in line
- Suction		4
- Injection system		Turbocharged, cooled
- Ignition sequence		Direct
- Clearance of rocker valve (cold)		1.3.4.2.
. Inlet		0,20 mm (0.008 in)
. Exhaust		0,45 mm (0.02 in)
- Capacity		4400 cm <sup>3</sup> (269 in <sup>3</sup> )
- Bore		105 mm (4.1 in)
- Stroke		127 mm (5.0 in)
- Compression ratio		17,5/1
- Nominal rating loaded		2300 rpm
- Rating slow unladen		850 + 20 rpm
- Max. rating unladen		2460 rpm
- Power ISO/TR 14396		124 cv/91 kw

- Power ISO/TR 14350
- Maximum torque ISO/TR 14396
- Air cleaner

124 cv/91 kW  
434 Nm à 1400 rpm (320 ft/lb)  
Sec 3 µ

## **COOLING CIRCUIT**

---

- Type By water
- Fan Puller
  - . Number of blades 10
  - . Diameter 508 mm (20 in)
- Thermostat
  - . Start opening 174 °F/183 °F
  - . Full opening 200 °F

## **TRANSMISSION**

---

- Type **DANA**
- Torque converter **DANA**
- Gear box
  - . Gear shifting Electro-hydraulic
  - . Number of forward speeds 4
  - . Number of reverse speeds 3
- Gear reverser Electro-hydraulic

## **FRONT AXLE**

---

- Type **DANA**
- Limited slip differential 45 %
- Hub reducers Epicyclic

## **REAR AXLE**

---

- Type **DANA**
- Limited slip differential 45 %
- Hub reducers Epicyclic

2 - 6

## **CONTENTS**

## **BRAKE**

---

- Service brake
  - . Type Foot pedal. Hydraulic servo-brake, applied on the front and rear wheels.
  - . Multidisc brake immersed in oil.
- Type of pump Gear pump.
  - . Capacity 4,8 cm<sup>3</sup> (0.3 in<sup>3</sup>)
  - . Pressure 120 Bar (1740 psi)
  - . Max. rating capacity unladen 12 L/mn (3.2 gal/min)
- Filtration 10 µ
  - . Pollution abatement Mechanical hand lever applied on the the front wheels.
- Parking brake
  - . Type Multidisc brake immersed in oil.

## **ELECTRIC CIRCUIT**

---

- Earth Negative
- Battery 12 V - 110 Ah - 750 A EN
- Alternator 12 V - 75 A
  - . Type Denso A115i
  - . Tension regulator Incorporated into the alternator
- Starter 12 V - 3,0 kW
  - . Type Denso F95B

## CONTENTS

**CHARACTERISTICS****MLA 628 -120 LSU POWERSHIFT Series 3-E2  
with simple carriage****FRONT AND REAR TIRES**

DIMENSIONS	PRESSURE	TIRE LOAD		PRESSURE ON THE CONTACT SURFACE		AREA OF THE CONTACT SURFACE	
				HARD GROUND	LIGHT GROUND	HARD GROUND	LIGHT GROUND
<b>15,5/80-24 SGI 10PR TUBELESS GOODYEAR</b>	<b>3,3 BAR (48 PSI)</b>	FRONT UNLADEN	2976 LB	KG/CM2	KG/CM2	CM2	CM2
		FRONT LADEN	8267 LB	KG/CM2	KG/CM2	CM2	CM2
		REAR UNLADEN	4409 LB	KG/CM2	KG/CM2	CM2	CM2
		REAR LADEN	1874 LB	KG/CM2	KG/CM2	CM2	CM2
<b>445/70R24 MPT IT510 151G TUBELESS GOODYEAR</b>	<b>4,1 BAR (60 PSI)</b>	FRONT UNLADEN	2976 LB	114 LB/IN2	38 LB/IN2	26 IN2	77 IN2
		FRONT LADEN	8267 LB	136 LB/IN2	45 LB/IN2	60 IN2	180 IN2
		REAR UNLADEN	4409 LB	125 LB/IN2	41 LB/IN2	35 IN2	107 IN2
		REAR LADEN	1874 LB	103 LB/IN2	34 LB/IN2	18 IN2	54 IN2
<b>460/70R24 IT520 150A8 TUBELESS GOODYEAR</b>	<b>3,3 BAR (48 PSI)</b>	FRONT UNLADEN	2976 LB	122 LB/IN2	31 LB/IN2	24 IN2	95 IN2
		FRONT LADEN	8267 LB	163 LB/IN2	43 LB/IN2	50 IN2	193 IN2
		REAR UNLADEN	4409 LB	135 LB/IN2	33 LB/IN2	34 IN2	132 IN2
		REAR LADEN	1874 LB	121 LB/IN2	32 LB/IN2	16 IN2	59 IN2
<b>17,5LR24 XM27 145A8 TUBELESS MICHELIN</b>	<b>3,2 BAR (47 PSI)</b>	FRONT UNLADEN	2976 LB	18 LB/IN2	17 LB/IN2	164 IN2	172 IN2
		FRONT LADEN	8267 LB	39 LB/IN2	36 LB/IN2	209 IN2	230 IN2
		REAR UNLADEN	4409 LB	25 LB/IN2	22 LB/IN2	178 IN2	196 IN2
		REAR LADEN	1874 LB	12 LB/IN2	12 LB/IN2	153 IN2	160 IN2
<b>19,5LR24 XM27 149A8 TUBELESS</b>	<b>3 BAR (44 PSI)</b>	FRONT UNLADEN	2976 LB	KG/CM2	KG/CM2	CM2	CM2
		FRONT LADEN	8267 LB	KG/CM2	KG/CM2	CM2	CM2
		REAR UNLADEN	4409 LB	KG/CM2	KG/CM2	CM2	CM2
		REAR LADEN	1874 LB	KG/CM2	KG/CM2	CM2	CM2

**IMPORTANT**

*When changing or replacing the tires and wheels; use only the manufacturer's approved components as installed at the factory. Any substitutes or modifications must first be approved by the manufacturer.*

**HYDRAULIC CIRCUIT**

- Type of pump	Variable displacement piston pump
. Capacity	63 cm <sup>3</sup> (3.8 in <sup>3</sup> )
. Max. rating capacity unladen	155 L/mn (41 gal/min)
. Flow rate at 2300 rpm	145 L/mn (38 gal/min)
. Flow rate at 1600 rpm	101 L/mn (26.7 gal/min)
- Pressure	
. Lifting, tilting, telescoping, attachment circuit	270 Bar (3915 psi)
. Steering circuit	175 Bar (2537 psi)
- Filtration	
. Return	25 μ
. Suction	125 μ

**CONTENTS****SPECIFICATIONS "WITH SIMPLE CARRIAGE"**

- Level of sound pressure in the driver's cab LpA (according to standard prEN 12053 : 1995)	73 dB
- Level of sound power in the LwA environment (according to directive 2000/14 CE guaranteed)	107 dB
- Speed of movement of lift truck in standard configuration on horizontal ground (except particular conditions)	
. Forward unladen	30 km/h (18.6 mph)
. Reverse unladen	20,9 km/h (13 mph)
- Standard lift height	5110 mm (201.2 in)
- Rated capacity with standard attachment	2500 kg (5512 lb)
- Load center	24 in.
- Weight of forks (each)	72 kg (159 lb)
- Lifting motions (boom retracted)	
. Unladen lifting	6,5 s
. Laden lifting	6,9 s
. Unladen lowering	4,6 s
	34,9 m/mn (114.5 ft/min)
	32,9 m/mn (108 ft/min)
	49,3 m/mn (162 ft/min)

. Unladen lowering	4,0 s	49,3 m/mn (162 ft/min)
. Laden lowering	4,6 s	49,3 m/mn (162 ft/min)
- Telescoping motions (lifting boom)		
. Unladen extending	3,9 s	21,5 m/mn (71 ft/min)
. Laden extending	4,1 s	20,5 m/mn (67 ft/min)
. Unladen retracting	2 s	42 m/mn (138 ft/min)
. Laden retracting	2,2 s	38,2 m/mn (125 ft/min)
- Reverse tilt time unladen	3,6 s	44,7 °/s
- Forward tilt time unladen	2,5 s	64,3 °/s
- Lift truck weight with standard attachment		
. Unladen	6730 kg (14837 lb)	
. Rated load	9230 kg (20349 lb)	
- Axle weight with attached equipment (transport position)		
. Front unladen	2740 kg (6041 lb)	
rated load	7520 kg (16579 lb)	
. Rear unladen	3990 kg (8796 lb)	
rated load	1710 kg (3770 lb)	
- Tensile strain at coupling hook		
. Unladen	5800 daN (13038 ft/lb)	
. Rated load	9400 daN (21131 ft/lb)	
- Break out force with bucket (according to standard iso 8313)	5800 daN (13038 ft/lb)	

2 - 9

## CONTENTS

### ***DIMENSIONS AND LOAD CHART***

### ***MLA 628 -120 LSU POWERSHIFT Series 3-E2 with simple carriage***

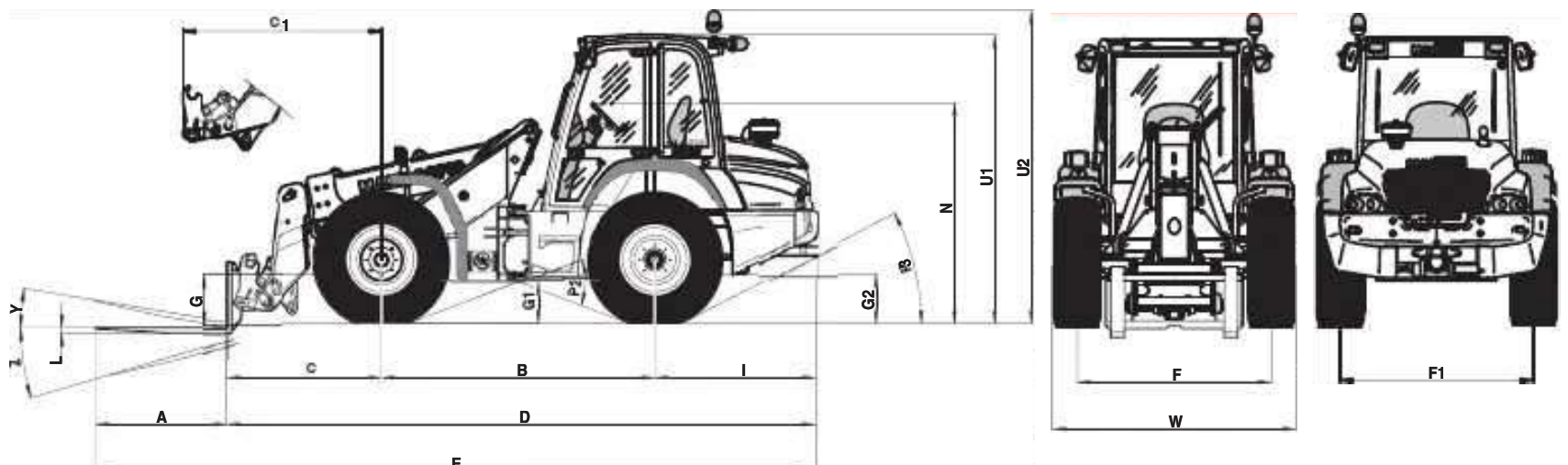

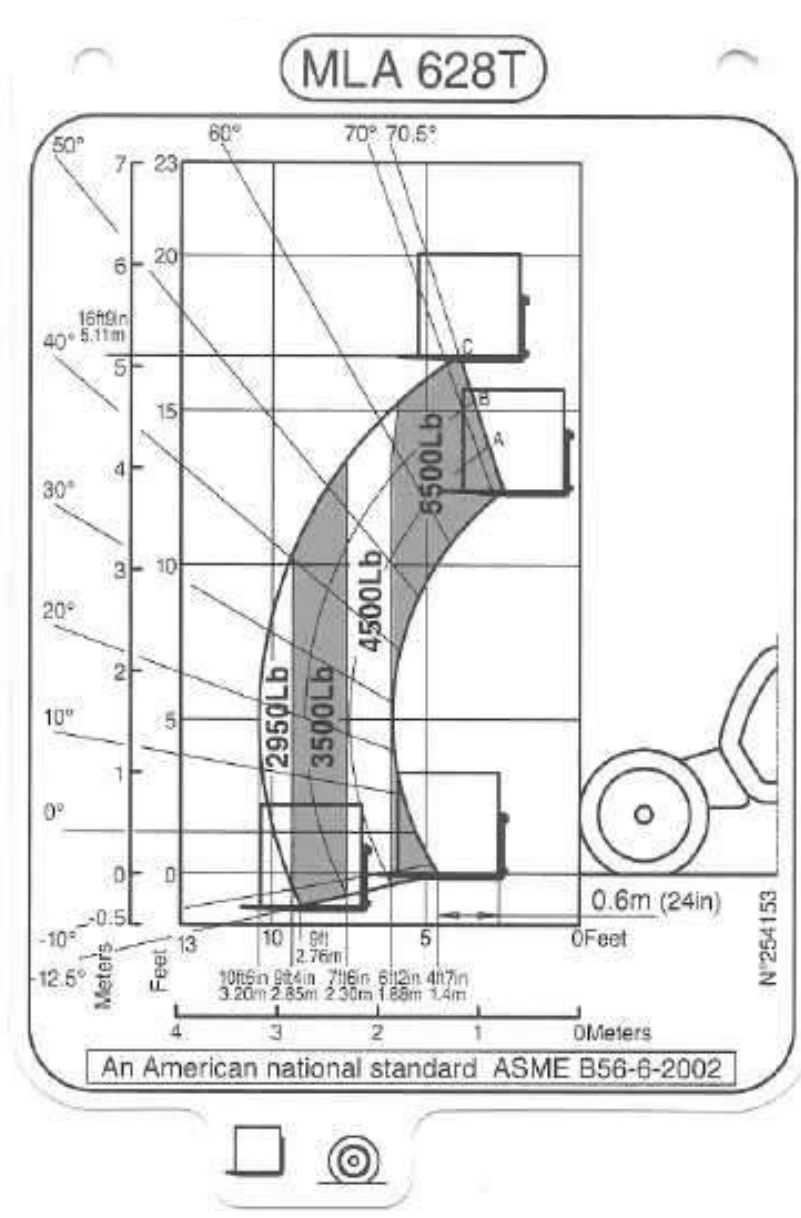
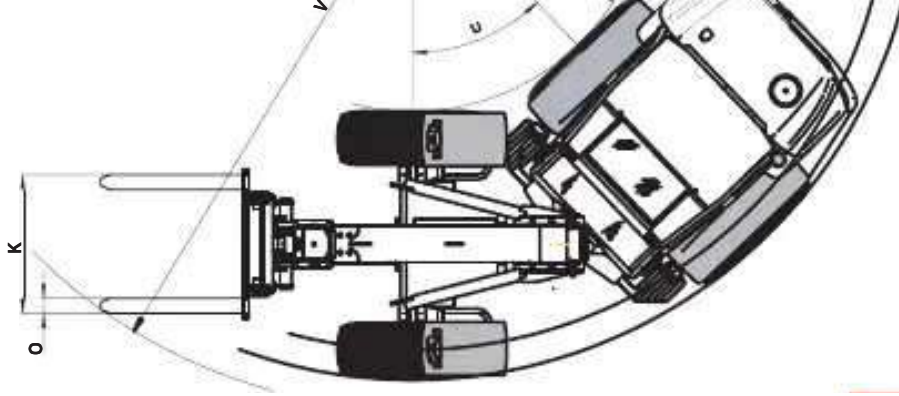

<b>A</b>	1200 mm (47.2 in)
<b>B</b>	2500 mm (98.4 in)
<b>C</b>	1419 mm (55.9 in)
<b>C1</b>	1821 mm (71.7 in)
<b>D</b>	5394 mm (212.4 in)
<b>E</b>	6594 mm (259.6 in)
<b>F</b>	1770 mm (69.7 in)
<b>F1</b>	1770 mm (69.7 in)
<b>G</b>	455 mm (17.9 in)
<b>G1</b>	390 mm (15.4 in)
<b>G2</b>	460 mm (18.1 in)
<b>I</b>	1475 mm (58.1 in)
<b>K</b>	1260 mm (49.6 in)
<b>L</b>	45 mm (1.8 in)
<b>N</b>	2050 mm (80.7 in)
<b>O</b>	125 mm (4.9 in)
<b>P2</b>	42 °
<b>P3</b>	27 °
<b>R</b>	4005 mm (157.7 in)
<b>U</b>	44 °
<b>U1</b>	2645 mm (104.1 in)
<b>U2</b>	2860 mm (112.6 in)
<b>V</b>	4500 mm (177.2 in)
<b>V1</b>	2005 mm (78.9 in)
<b>V2</b>	4233 mm (166.7 in)
<b>W</b>	2225 mm (87.6 in)
<b>Y</b>	10 °
<b>Z</b>	151 °



CONTENTS

**INSTRUMENTS AND CONTROLS**

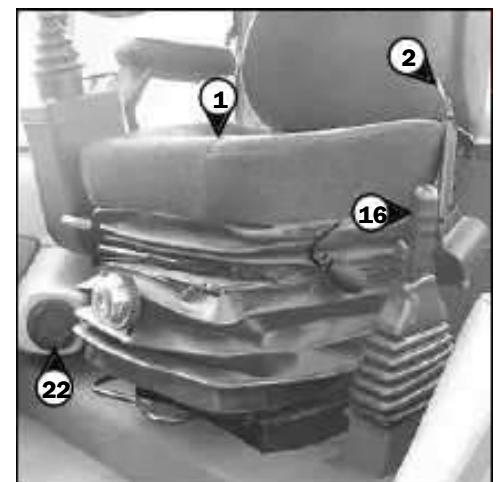

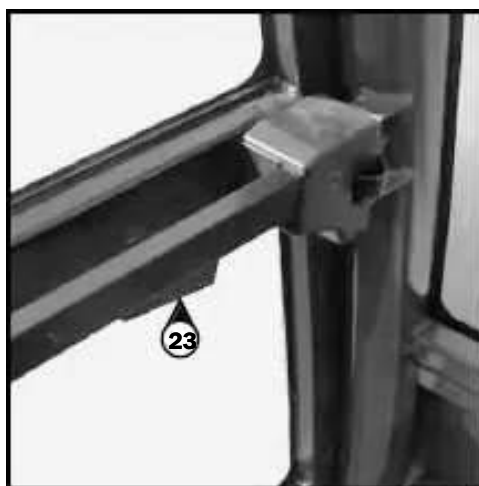
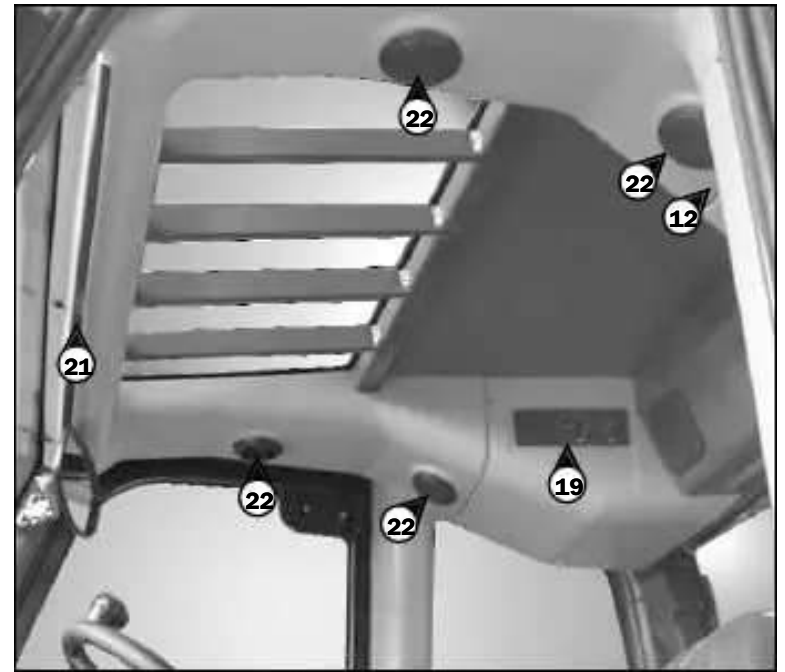
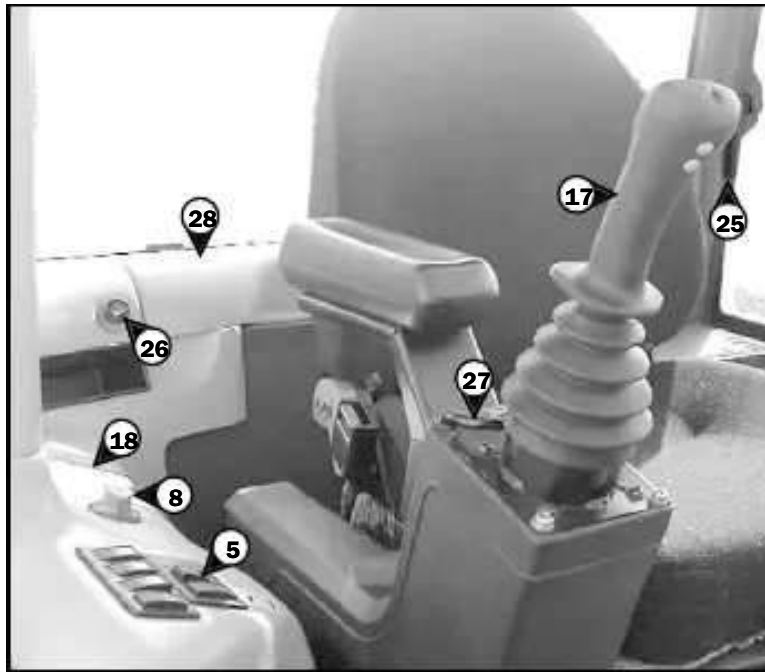

**CONTENTS**

**DESCRIPTION**

- 1 - DRIVER'S SEAT
- 2 - SAFETY BELT
- 3 - CONTROL AND SIGNAL LIGHTS PANEL
- 4 - N/A
- 5 - SWITCHES PANEL
- 6 - LIGHT SWITCH, HORN AND INDICATOR SWITCH
- 7 - IGNITION SWITCH
- 8 - BATTERY CUT-OFF
- 9 - WINDSCREEN WASHER TANK (NOT ILLUSTRATED)
- 10 - FUSES AND RELAY ACCESS PANEL
- 11 - FUSE AND RELAY
- 12 - ROOF LIGHT
- 13 - ACCELERATOR PEDAL
- 14 - SERVICE BRAKE PEDAL AND TRANSMISSION CUT-OFF
- 15 - FORWARD/REVERSE LEVER AND GEAR SELECTOR
- 16 - PARKING BRAKE LEVER
- 17 - HYDRAULIC CONTROLS AND TRANSMISSION CUT-OFF
- 18 - LOAD CHARTS FILE
- 19 - HEATER CONTROL
- 19 - AIR CONDITIONING CONTROLS (OPTION AIR CONDITIONING)
- 20 - CAB FILTER VENTILATORS (NOT ILLUSTRATED)
- 21 - WINDSCREEN DEMIST VENTS
- 22 - HEATING VENTS

- 23 - DOOR LOCKS
- 24 - RELEASING BUTTONS FOR UPPER DOORS
- 25 - SIDE WINDOW OPENING HANDLES
- 26 - CIGAR LIGHTER
- 27 - ARM REST LIFTING HANDLE
- 28 - TOOL BOX AND DOCUMENT HOLDER
- 29 - FRONT LIGHTS (NOT ILLUSTRATED)
- 30 - REAR LIGHTS (NOT ILLUSTRATED)
- 31 - REVOLVING LIGHT (NOT ILLUSTRATED)
- 32 - FRONT WORKING TAIL LIGHT (NOT ILLUSTRATED)
- 33 - REAR WORKING TAIL LIGHT (NOT ILLUSTRATED)
- 34 - REAR REFLECTORS (NOT ILLUSTRATED)
- 35 - STEERING WHEEL REGULATING HANDLE
- 36 - DIAGNOSTIC CONNECTOR
- 37 - REAR ELECTRIC SOCKET (NOT ILLUSTRATED)

NOTE : All the terms such as : RIGHT, LEFT, FRONT, REAR are meant for an observer seated on driver's seat facing forward.

## CONTENTS

### 1 - DRIVER'S SEAT (STANDARD)

DESIGNED FOR MAXIMUM COMFORT, THIS SEAT CAN BE ADJUSTED AS FOLLOWS.

#### FRONT TO BACK ADJUSTMENT OF THE ARMREST

- Pull lever 1 upwards.
- Slide the upper section of the seat until the arm rests comfortably on the armrest 2.
- Release the lever making sure it is locked.

#### FRONT TO BACK ADJUSTMENT OF THE SEAT

- Pull lever 3 upwards.
- Slide the entire seat to obtain a comfortable driving position.
- Release the lever making sure it is locked.

#### ADJUSTING SEAT FLEXIBILITY

- Turn the knob 4 according to driver's weight

#### ADJUSTING SEAT TILT

- Lean back against the back of the seat.
- Pull lever 5 and place the seat in the desired position.

#### ADJUSTING THE LUMBAR REGION

- Set the pneumatic pressure in the back of the seat as required.
- Pump with the squeezer 6 to increase the pneumatic pressure.

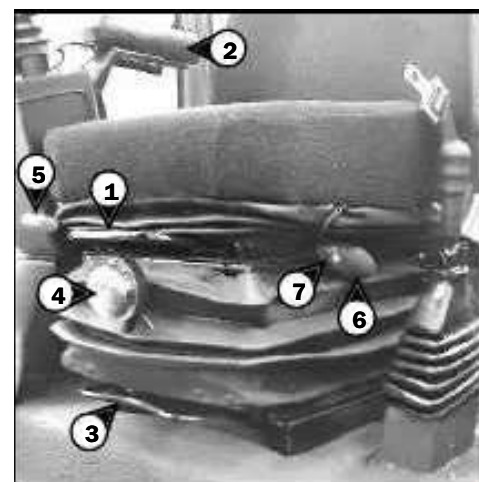

## 1 - PNEUMATIC DRIVER'S SEAT (OPTION)

DESIGNED FOR MAXIMUM COMFORT, THIS SEAT CAN BE ADJUSTED AS FOLLOWS.

### WEIGHT AND SEAT HEIGHT ADJUSTMENT

#### WEIGHT ADJUSTMENT

It is advised that you adjust the seat according to your weight when sitting.

- Switch on lift truck ignition.
- Push or pull lever 1 until green appears in display 2 indicating correct adjustment according to your weight.

NOTE : To avoid any health problems, it is recommended that the weight should be checked and adjusted before starting up the lift truck.

#### SEAT HEIGHT ADJUSTMENT

When weight adjustment has been carried out, you can then modify seat height.

- Keep the ignition switched on.
- Push or pull lever 1 until green appears and adjust the height of the seat while checking that the green in display 2 remains visible.

<b>IMPORTANT</b>	<i>To avoid causing any damage, do not activate the compressor for over 1 minute.</i>
------------------	---

### ADJUSTMENT OF THE ANGLE OF THE BACK-REST

- Support the back-rest, pull the lever and position the back-rest to find the desired position.

 <b>CAUTION</b>	<i>If you do not support the back-rest when making adjustments, it swings completely forwards.</i>
--	--

### LONGITUDINAL ADJUSTMENT

- Pull locking lever 1 towards the right.
- Slide the seat to the required position.
- Release the lever and be sure it returns to the lock position.

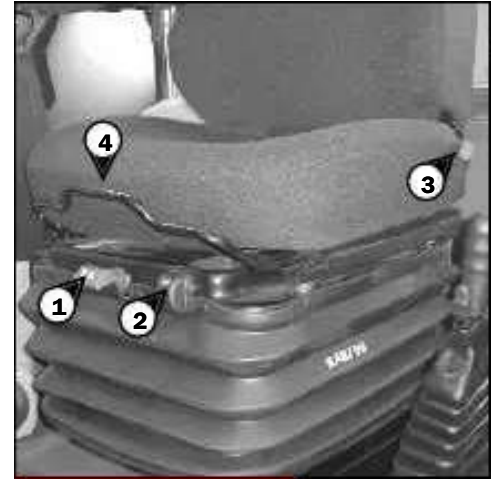

## 2 - SAFETY BELT

- Sit correctly on the seat.
- Check that seat belt is not twisted.
- Place the seat belt at hip level.
- Attach the seat belt and check that it locks.
- Adjust the seat belt to your body shape without squeezing your hip and without over-slack.

 <b>WARNING</b>	<i>Do not operate the lift truck with a defective seat belt (fixing, locking, cuts, tears, etc.). Repair or replace the seat belt immediately.</i>
--	--

## 3 - CONTROL AND SIGNAL LIGHTS PANEL

### CONTROL INSTRUMENTS

#### A - HOURMETER AND REV COUNTER

#### B - I.C. ENGINE WATER TEMPERATURE

- Temperature zone
- B1 - Blue zone (32°F - 122°F)
  - B2 - Green zone (122°F - 176°F)
  - B3 - Black/red zone (212°F - 221°F)
- <https://www.forkliftpdfmanuals.com/>

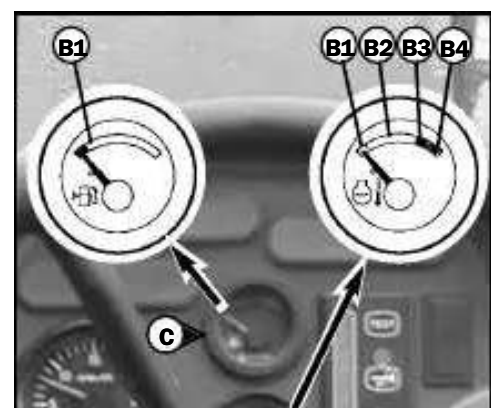

NOTE : Red indicator light "J" comes on between zone B3 and B4.

### C - FUEL LEVEL

Red zone C1 indicates that you are using the reserve supply and that time of use is limited.



## **SIGNAL LIGHTS**

When activating the electrical system of the lift truck, all the red lamps and the panel's buzzer must light to indicate their good working order. If one of the red lamps or the buzzer does not function, carry out the necessary repairs.

### D - RED LAMP - HYDRAULIC RETURN FILTER CLOGGED

The lamp and buzzer come on when the hydraulic return oil filter cartridge is clogged up. Park the lift truck and carry out the necessary repairs (see cleaning and replacement requirements in chapter : 3 - MAINTENANCE : FILTERS CARTRIDGES AND BELTS).

### E - RED TRANSMISSION OIL TEMPERATURE LAMP

The lamp and the buzzer come on when the converter oil temperature is abnormally high. Park the lift truck and look for the cause of this overheating.

### F - RED BRAKING OIL PRESSURE LAMP

If the lamp and the buzzer come on when the lift truck is running, stop the I.C. engine immediately and investigate the cooling system for the cause of the malfunction.

### G - RED PARKING BRAKE LAMP

This lamp comes on when the parking brake is applied.

### H - RED ALTERNATOR CHARGE LAMP

If the lamps E - F - H - I - J - K and the buzzer come on, when the lift truck is running, stop the I.C. engine immediately and check the electrical circuit as well as the alternator belt.

### I - RED I.C. ENGINE OIL PRESSURE LAMP

If the lamp and the buzzer come on when the lift truck is running, stop the I.C. engine immediately and look for the cause (see oil level in I.C. engine crankcase).

### J - RED I.C. ENGINE WATER TEMPERATURE LAMP

If the lamp and the buzzer come on when the lift truck is running, stop the I.C. engine immediately and investigate the cooling system for the cause of the malfunction.

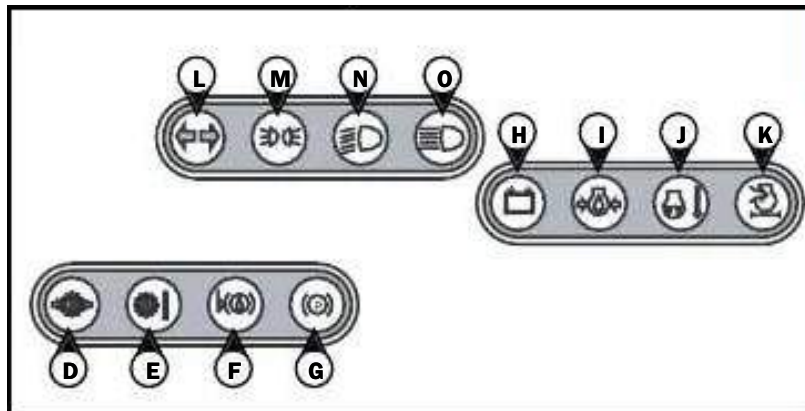

## **CONTENTS**

### K - RED LAMP - AIR FILTER OR HYDRAULIC RETURN FILTER CLOGGED

The lamp and buzzer come on when the air filter cartridge or the hydraulic return oil filter cartridge is clogged up. Park the lift truck and carry out the necessary repairs (see cleaning and replacement requirements in chapter : 3 - MAINTENANCE : FILTERS CARTRIDGES AND BELTS).

### L - GREEN INDICATOR LAMP

### M - GREEN SIDELIGHTS LAMP

### N - GREEN LOW BEAM LAMP

### O - BLUE MAIN BEAM LAMP

## **4 - N/A**

## CONTENTS

**5 - SWITCHES PANEL****A - WORKING HEAD LIGHT****B - OPTION BOOM HEAD LIGHT****C - WORKING TAIL LIGHT****D - WARNING LIGHTS**

This switch enables the L.H. and R.H. Indicators to be switched on simultaneously, with the ignition off. The signal light indicates that the switch is being used.

**E - OPTION REAR WINDOW DEFROSTING****F - FRONT WINDSCREEN WIPER****G - FRONT WINDSCREEN WASHER****H - OPTION****I - OPTION**

- OPTION Electrovalve on boom head.
- OPTION Attachment hydraulic locking device.
- OPTION Electrical boom provision <https://www.forkliftpdfmanuals.com/>
- OPTION Electrovalve on boom head + attachment hydraulic locking device.

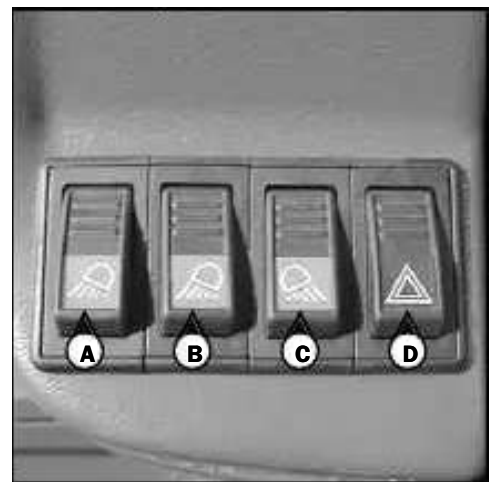

See : 2 - DESCRIPTION : DESCRIPTION AND USE OF ELECTRIC AND HYDRAULIC OPTIONS.



### J - TRANSMISSION CUT-OFF

The switch selects transmission cut-off to the service brake pedal or the hydraulic controls lever.

Position A : Indicator light on, transmission cut-off to service brake pedal effected.

Position B : Indicator light off, transmission cut-off to hydraulic control lever effected.

NOTE : Transmission cut-off can only be carried out when the speed is less than 7 mph.

### USE OF TRANSMISSION CUT-OFF

Transmission cut-off to brake pedal (position A).

• When loading.

Transmission cut-off to hydraulic controls lever (position B).

- When driving.
- For inching and continuous stopping and starting (delicate handling). In order to optimize hydraulic movements, cut off transmission to the hydraulic controls lever.
- Starting up on a slope.

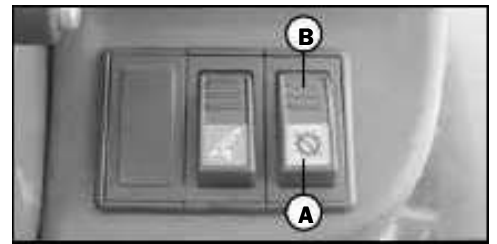

### K - OPTION ROOF WIPER

### L - REAR WINDSCREEN WIPER AND WINDSCREEN WASHER

### M - FLASHING LIGHT

### N - KICK-DOWN SWITCH <-> OPTION BOOM HEAD ELECTROVALVE

See : 2 - DESCRIPTION : 15 - FORWARD/REVERSE LEVER AND GEAR SELECTOR.

### O - OPTION BOOM SUSPENSION

See : 2 - DESCRIPTION : DESCRIPTION AND USE OF ELECTRIC AND HYDRAULIC OPTIONS.

### P - OPTION

### Q - OPTION

- OPTION Dual effect hydraulic towing hook.
- OPTION Single or dual effect rear hydraulic predisposition.

See : 2 - DESCRIPTION : DESCRIPTION AND USE OF ELECTRIC AND HYDRAULIC OPTIONS.

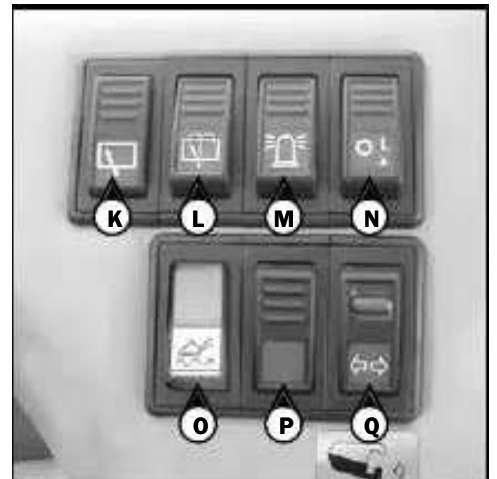

## CONTENTS

### 6 - LIGHT SWITCH, HORN AND INDICATOR SWITCH

The switch controls the visual and sound alarms.

- A - All lights are off, the direction indicators do not flash.
- B - The right hand direction indicators flash.
- C - The left hand direction indicators flash.
- D - The sidelights and the rear lights are on.
- E - The dipped headlights and the rear lights are on.
- F - The main beam headlights and the rear lights are on.
- G - Headlight signal.

Pressing the switch sounds the horn.

NOTE : The positions D - E - F - G can be carried out without the ignition being on.

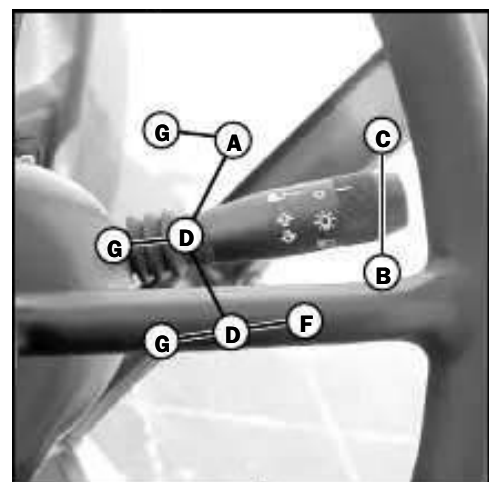

### 7 - IGNITION SWITCH

The key switch has five positions :

- P - Ignition off, parking position.
- O - Ignition switched off and I.C. engine stopped.
- I - Ignition on.
- II - Heating.
- III - The I.C. engine starts, return to position I as soon as the key is released.

## 8 - BATTERY CUT-OFF



## 9 - WINDSCREEN WASHER TANK

Located on the right side of the engine compartment.  
See : 3 - MAINTENANCE : B - EVERY 50 HOURS SERVICE.

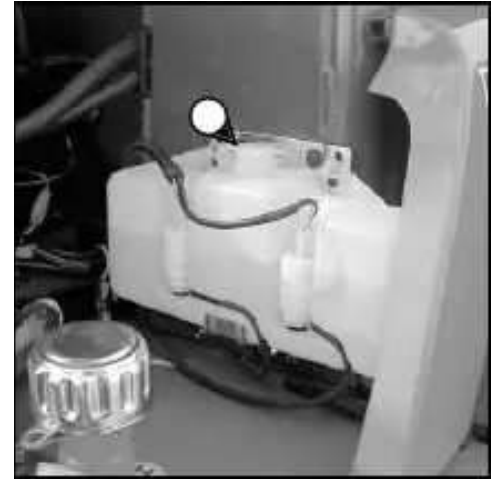

## 10 - FUSE AND RELAY ACCESS PANEL

- Lift up the fuse and relay access panel 1.

NOTE : To access fuses F31, F32 and relays K8 to K17 and K21, you need to disassemble the access panel 2.

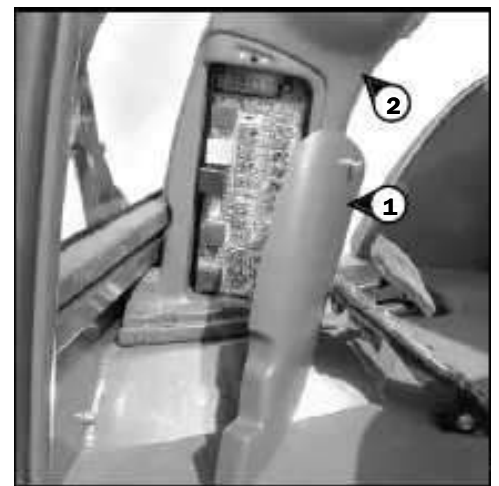

2 - 18

## CONTENTS

## 11 - FUSE AND RELAY

A decal on the inside of the access panel gives a clear display of the use of the components described below.

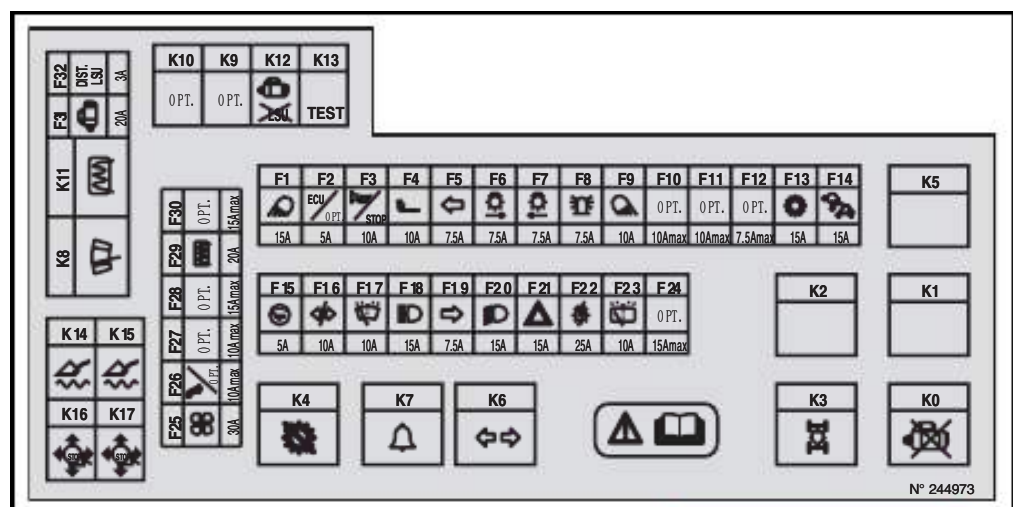

K0 - safety system starting switch relay.

K1 - OPTION.

K2 - OPTION.

K3 - Reverse gear relay.

K4 - Transmission cut-off relay.

K5 - Hydraulic return filter clogged.

K6 - Flashing unit.

K7 - Buzzer

K8 - Front windscreen wiper.

K9 - OPTION Electrovalve on boom head.

- OPTION Electrovalve on boom head + attachment hydraulic locking device.

K10 - OPTION Air conditioning.

K11 - Rear window defrosting

K12 - Electroproportional hydraulic control modules. **MLA 628 -120 LSU POWERSHIFT Series 3-E2**

K13 - Test relay.

K14 - OPTION Boom suspension relay.

K15 - OPTION Boom suspension cut-off relay.

K16 - OPTION Hydraulic movements cut-off. <https://www.forkliftpdfmanuals.com/>

K17 - OPTION



- K18 - Preheating I.C. engine.
- K19 - Rear windscreen wiper.
- K20 - Transmission cut-off relay module.
- K21 - Gear reverser micro relay.
- K22 - OPTION Cutting off "aggravating" hydraulic movements modules. **MLA 628 -120 LSU POWERSHIFT Series 3-E2**
- K23 - OPTION Cutting off "aggravating" hydraulic movements. **MLA 628 -120 LSU POWERSHIFT Series 3-E2**
- K24 - OPTION Diesel decongealant.

NOTA : Remplacer un fusible usagé par un fusible neuf de même qualité et capacité. Ne jamais réutiliser un fusible réparé.

- F1 - (15A MAX.) - Front working head light (15A).
- F2 - (5A MAX.) - Variable displacement piston pump (5A). **MLA 628 -120 LSU POWERSHIFT Series 3-E2**
- F3 - (10A MAX.) - Sound alarm (10A).
  - Stop switch (10A).
- F4 - (10A MAX.) - Cigar lighter (10A).
- F5 - (7,5A MAX.) - Left indicators (7,5A).
- F6 - (10A MAX.) - Right sidelights (7,5A).
  - Fuel gauge lighting (7,5A).
  - Hourmeter lighting (7,5A).
- F7 - (10A MAX.) - Left sidelights (7,5A).
  - OPTION Number plate lighting (7,5A).
- F8 - (10A MAX.) - Flashing light (7,5A).
- F9 - (10A MAX.) - Working tail light (10A).
- F10 - (10A MAX.) - OPTION Boom head light (10A).
- F11 - (10A MAX.) - Air conditioning (7,5A).
  - OPTION Electrovalve on boom head (10A).
  - OPTION Electrovalve on boom head + attachment hydraulic locking device (10A).
- F12 - (7,5A MAX.) - OPTION Roof windscreen wiper (7,5A).
- F13 - (15A MAX.) - Gear reverser (15A).
  - Transmission cut-off (15A).
- F14 - (15A MAX.) - Stop engine electrovalve (15A).
  - OPTION Hydraulic movements cut-off (10A).
- F15 - (10A MAX.) - Signal lamp panel (5A).
  - Fuel gauge (5A).
  - Hourmeter (5A).
  - Buzzer (5A).
- F16 - (10A MAX.) - Indicators power supply (10A).
- F17 - (10A MAX.) - Front windscreen wiper (10A).
  - Front windscreen washer (10A).

## CONTENTS

- F18 - (15A MAX.) - Main beam (15A).
  - Main beam lamp (15A).
- F19 - (10A MAX.) - Right indicators (7,5A).
- F20 - (15A MAX.) - Low beam (15A).
- F21 - (15A MAX.) - Hazard warning lights power supply (15A).
  - Roof light (15A).
- F22 - (25A MAX.) - Light switch power supply, horn and indicators (25A).
- F23 - (10A MAX.) - Rear windscreen wiper (7,5A).
  - Rear windscreen washer (7,5A).
- F24 - (15A MAX.) - OPTION Pneumatic seat (15A).
- F25 - (30A MAX.) - Heating (30A).
- F26 - (10A MAX.) - OPTION
- F27 - (10A MAX.) - OPTION Rear hydraulic provision (10A).
  - OPTION Dual effect hydraulic towing hook (10A).
- F28 - (15A MAX.) - OPTION Boom suspension (10A).
  - OPTION
- F29 - (20A MAX.) - OPTION Rear window defrosting (20A).
- F30 - (15A MAX.) - OPTION 12V socket (15A).
  - OPTION (+) permanent (15A).
- F31 - (20A MAX.) - Starter (20A).
- F32 - (5A MAX.) - Electroproportional hydraulic control modules (3A).
  - OPTION Attachment hydraulic control forced operation (5A).
  - OPTION Coupure des mouvements hydrauliques "aggravants" (5A).

**MLA 628 -120 LSU POWERSHIFT Series 3-E2**

<http://www.forkliftparts.com/>

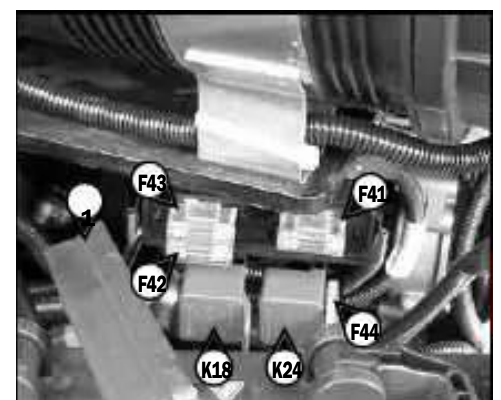
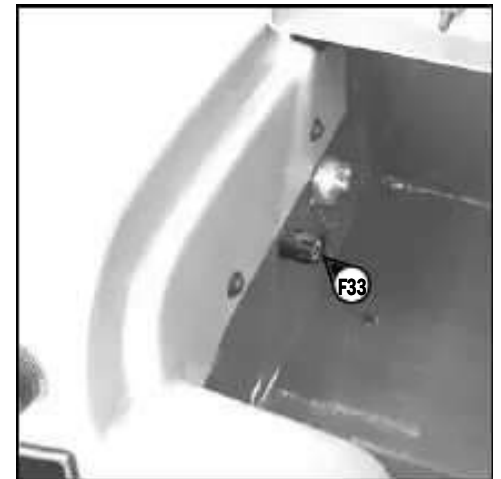



Lift the lid of the tool box for access to F33 fuses.

F33 - (1A MAX.) - Diagnostic connector (1A). **MLA 628 -120 LSU POWERSHIFT Series 3-E2**

Remove cover 1 for access to fuses F41 to F44.

F41 - (40A MAX.) - Lift truck electrical equipment (40A).

F42 - (80A MAX.) - Preheating I.C. engine (80A).

F43 - (80A MAX.) - Alternator (80A).

F44 - (15A MAX.) - OPTION Diesel decongealant (15A).

## 12 - ROOF LIGHT



## 13 - ACCELERATOR PEDAL

## 14 - SERVICE BRAKE PEDAL AND TRANSMISSION CUT-OFF

The pedal applies on the front and rear wheels by an hydraulic brake system, and allows the lift truck to be slowed down and stopped. Depending on the position of the transmission cut-off switch, it enables the free travel to cut off transmission (see : 2 - DESCRIPTION : 5 - SWITCHES PANEL).

## CONTENTS

## 15 - FORWARD/REVERSE LEVER AND GEAR SELECTOR

### DESCRIPTION

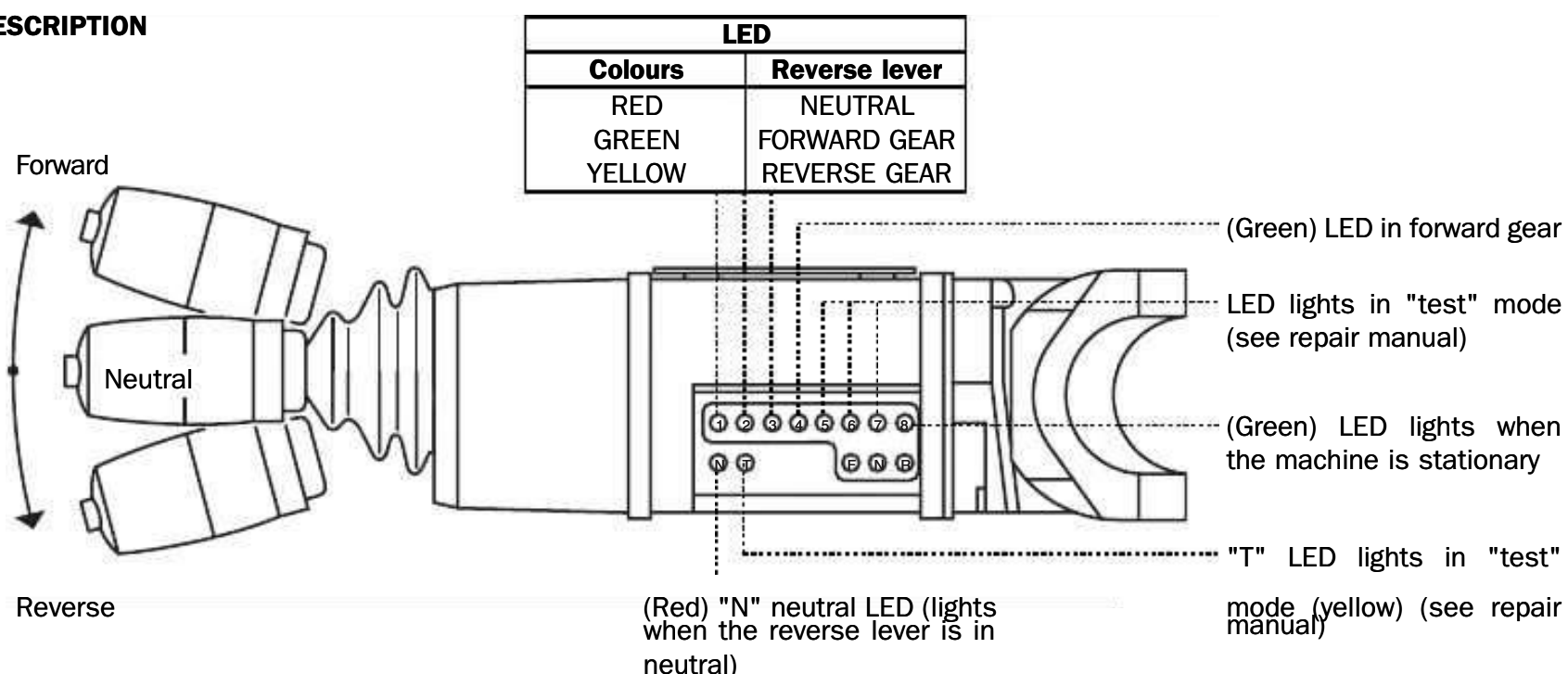

When operating this control, the lift truck should be travelling at low speed and not accelerating.

**IMPORTANT** During the direction change, depending on the original selection the speed may also change (see diagram A) it can be reset using the button 2 or 4 (kick down see diagram B/kick up see diagram C).

**FORWARD** : Push the lever forwards (Position A).  
**REVERSE** : Pull the lever backwards (Position B).  
**NEUTRAL** : To start the lift truck, the lever must be in neutral (Position C). After starting the

lift truck, the 3rd gear is automatically selected after a few seconds.

**NOTE** : The reverse lights indicate that the lift truck is running in reverse motion. As well, an **OPTION** sound alarm on reverse motion exists.



**GEAR SELECTOR**

The selected gear is indicated on display 1 by a signal light.

**FORWARD GEAR** : The gears can be gradually increased from the 1st to the 4th by turning the handle forwards or by a double pulse (< 0.5 seconds) (kick up) on the button 2 and decreased from the 4th to the 1st by turning the handle backwards or by a single pulse (kick down) on the button 2 or 4.

**REVERSE GEAR** : The gears can be gradually increased from the 1st to the 3rd by turning the handle forwards or by a double pulse (< 0.5 seconds) (kick up) on the button 2 and decreased from the 3rd to the 1st by turning the handle backwards or by a single pulse (kick down) on the button 2 or 4.

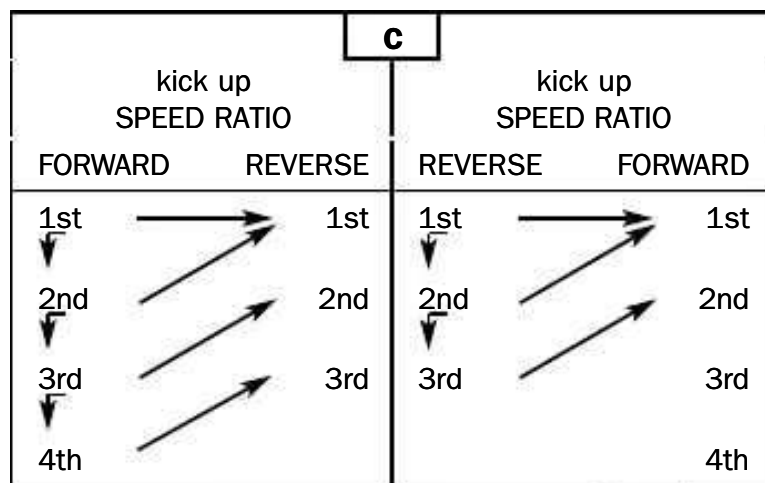
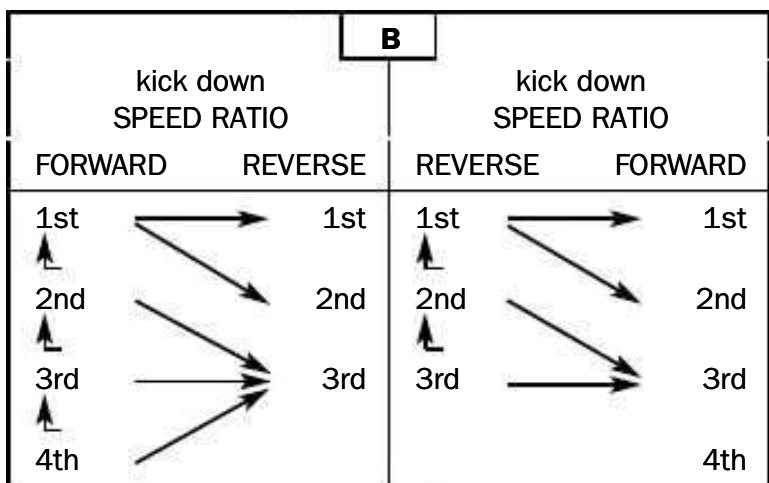
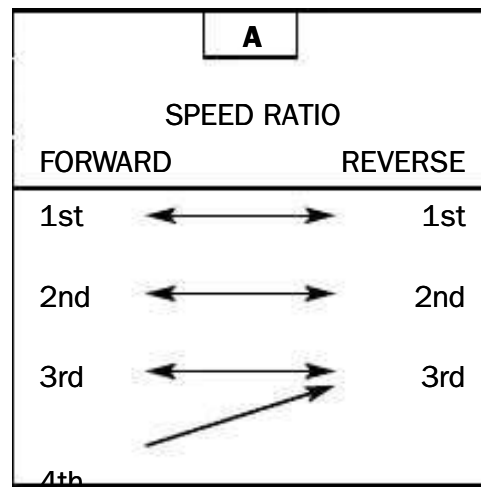

**CONTENTS**

**KICK-DOWN SWITCH <-> BOOM HEAD ELECTROVALVE**

Switch 3 selects kick-down with knob 4 on the hydraulic control lever or the solenoid valve at the boom head **OPTION**.

Position A : The LED is off, enabling kick-down with knob 4 on the hydraulic control lever.

Position B : The LED is on, enabling operation of the solenoid valve at the boom head with the hydraulic control lever.

**USING THE GEARS ON THE GEARBOX**

- On these lift trucks with a torque converter, it is not necessary to automatically start up in 1st speed and progress up the gears.



**IMPORTANT**

The choice of gear ratio should be made according to the nature of the work being carried out. A poor choice may quickly overheat the transmission oil through excessive slipping of the torque converter, causing serious damage to the transmission. It is essential to stop and change to the correct gear if the transmission oil temperature indicator light comes on. An incorrect gear selection may also result in a reduction in the lift truck's performance in forward speed. When the forward force or load increases, the forward speed (for example 3rd gear) may be slower than the forward speed that could be obtained with 2nd gear (instead of 3rd).

In general, we would advise you to use the following gears according to the nature of the work being carried out.

- On the road : Set off in 4th gear if the conditions and state of the road permit it. In hilly areas, set off in 3rd gear and go up to 4th if the conditions and state of the road permit it.

4th if the conditions and state of the road permit it.

- With a trailer on the road : Set off in 2nd gear and go up to 3rd and then to 4th if the conditions and state of the road permit it.
- Handling : 3rd or 4th gear.  
2nd gear in restricted spaces.
- Earth moving : 1st gear.
- Loading (reclaiming with bucket, manure fork, etc.) : 2nd gear.

## 16 - PARKING BRAKE LEVER

To prevent accidental loosening or release, the lever is fitted with safety locking.

- To apply the parking brake, pull the lever backwards (position A).
- To loosen the parking brake, release and push the lever forwards (position B).

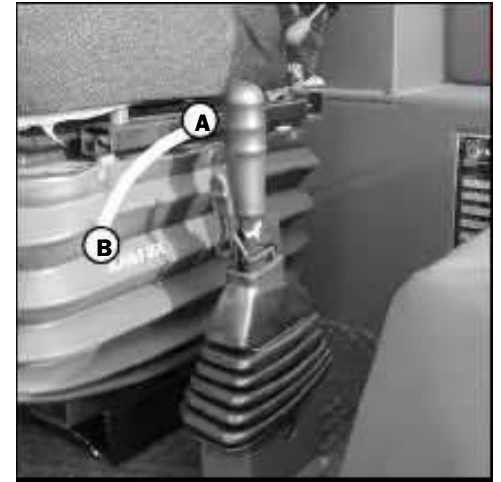

## 17 - HYDRAULIC CONTROLS AND TRANSMISSION CUT-OFF



### WARNING

Do not attempt to alter the hydraulic system pressure by interfering with the pressure regulating valve. In the event of suspected malfunction, contact your dealer. ANY ALTERATION MAY VOID THE WARRANTY.



### WARNING

Use the hydraulic controls carefully without sudden movements, to avoid accidents caused by shaking the lift truck.

### MLA 628 -120 LSU POWERSHIFT Series 3-E2

NOTE : If necessary use the steering to reset the hydraulic control steering accumulator.

#### LIFTING OF THE LOAD

- The lever A backwards when lifting.
- The lever A forwards when lowering.

#### TILT OF THE CARRIAGE

- The lever A to the left for reverse tilt.
- The lever A to the right for forward tilt.

#### TELESCOPING

- The button B up for the extension.
- The button B down for the retraction.

#### ATTACHMENT

The button C up or down

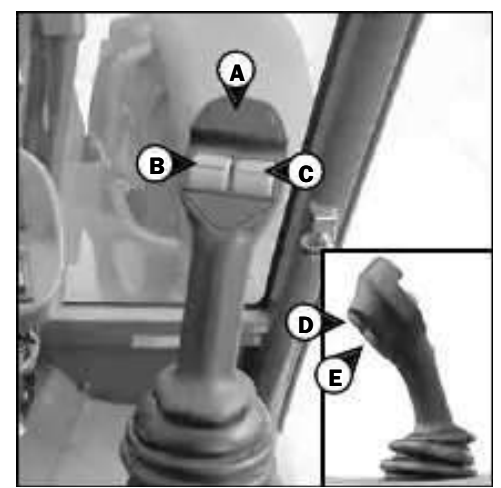
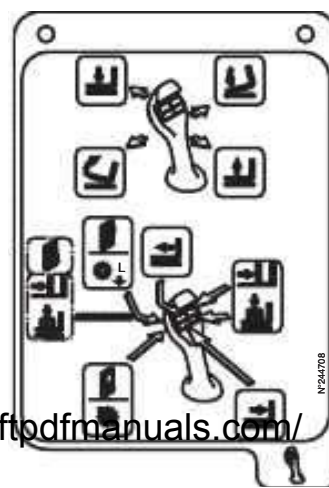

- The button C up or down.

### KICK-DOWN OR OPTION BOOM HEAD ELECTROVALVE

- Button D (see : 2 - DESCRIPTION : 5 - SWITCHES PANEL).

### TRANSMISSION CUT-OFF

- Button E (see : 2 - DESCRIPTION : 5 - SWITCHES PANEL).

## **18 - LOAD CHARTS FILE**

This file includes the description of the hydraulic controls and the load charts of the attachments used on the lift truck.

## **19 - HEATER CONTROL**

### **A - HEATING FAN CONTROL**

This 3-speed control regulates warm or cold air through the heating ventilators.

### **B - HEATING TEMPERATURE CONTROL**

Allows the temperature inside the cab to be adjusted.

B1 - With the valve closed, the fan delivers fresh air.

B2 - With the valve opened completely, the fan delivers warm air.

The intermediate positions allow the temperature to be adjusted.

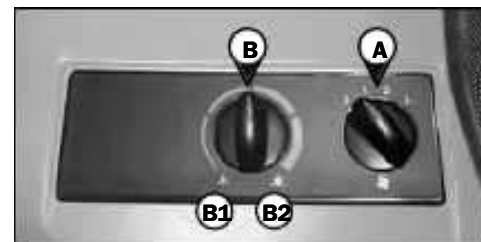

## **19 - AIR CONDITIONING CONTROLS (OPTION AIR CONDITIONING)**

### IMPORTANT

*The air conditioning operates only while the lift truck engine is running. During use, keep the doors and windows closed.*

*In the winter : To ensure correct operation and efficiency of the air conditioning unit, run the compressor once a week, for a few minutes, to lubricate the internal seals.*

*In cold weather : Warm the I.C. engine before switching on the compressor, this will allow the coolant that has collected in the liquid state at the lowest point of the compressor circuit to turn into gas by the heat given off by the I.C. engine (otherwise the compressor is liable to be damaged by pumping coolant in the liquid state when operated).*



### WARNING

*If your air conditioning does not seem to be working properly, have it examined by your dealer (see : 3 - MAINTENANCE : H - EVERY TWO YEARS "OPTION AIR CONDITIONING"). The air conditioning system is under high pressure, repairs must be made by a professional airconditioning repairman.*

### DESCRIPTION OF THE AIR CONDITIONING CONTROLS

A - Control with signal light indicating start-up and cutout of the air conditioning system, if control "D" is in position 1, 2 or 3.

B - Heating air temperature control.

C - Conditioned air temperature control.

D - Air flow setting and fan speed control. In position "0" the air conditioning system no longer functions.

<https://www.forkliftpdfmanuals.com/>

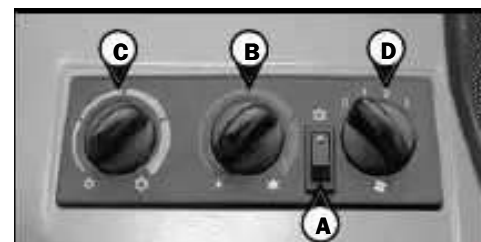

Possible losses of water under the forklift truck are due to condensate discharges caused by the drying effect of the installation, especially with high outside temperatures and high relative humidity.

For the air conditioning to perform properly, the air intakes must not be blocked by frost, snow or leaves.

When the unit is running, at least one of the cab air grilles must be open so as to avoid freezing-up the evaporator.

**HEATING MODE**

The controls must be adjusted in the following way :

- A - Control with signal light off.
- B - At the required temperature.
- C - At the end of travel to the left.
- D - At the required temperature 1, 2 or 3.

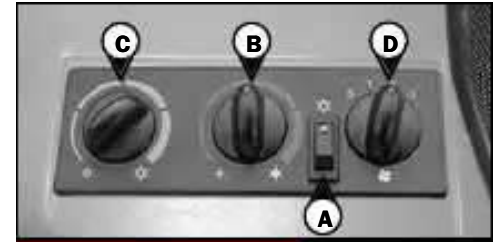
**CONDITIONED AIR MODE**

The controls must be adjusted in the following way :

- A - Control with signal light on.
- B - At the end of travel to the left.
- C - At the required temperature.
- D - At the required temperature 1, 2 or 3.

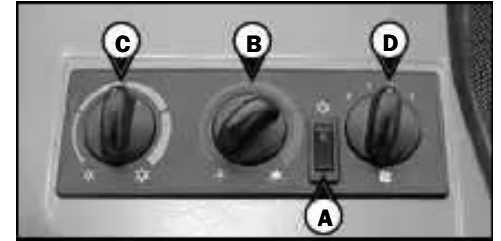
**DEMISTING MODE**

The controls must be adjusted in the following way :

- A - Control with signal light on.
- B - At the required temperature.
- C - At the required temperature.
- D - At the required temperature 1, 2 or 3.

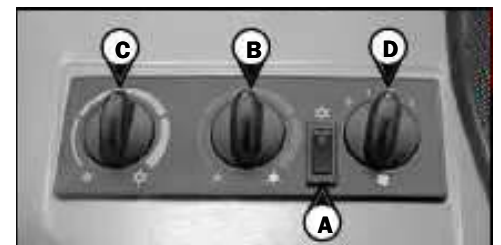
**20 - CAB FILTER VENTILATORS**

See : 3 - MAINTENANCE : D - EVERY 500 HOURS SERVICE.

**21 - WINDSCREEN DEMIST VENTS**

For optimum effectiveness, close the heating ventilators.

**22 - HEATING VENTS**

These heating vents enable the air to be directed to the interior of the cabin and onto the side windows.

**CONTENTS****23 - DOORS LOCKS**

Two keys are provided with the lift truck to enable the cabin to be locked.

**24 - RELEASING BUTTONS FOR UPPER DOORS****25 - SIDE WINDOW OPENING HANDLES****26 - CIGAR LIGHTER****27 - ARM REST LIFTING HANDLE****28 - TOOL BOX AND DOCUMENT HOLDER**

Ensure that the operator's manual is in its place in the document holder.

**29 - FRONT LIGHTS**

- A - Left front indicator.
- B - Left front dipped headlight.
- C - Left front main beam.
- D - Left front sidelight.
- E - Right front indicator.
- F - Right front dipped headlight.
- G - Right front main beam.
- H - Right front sidelight.

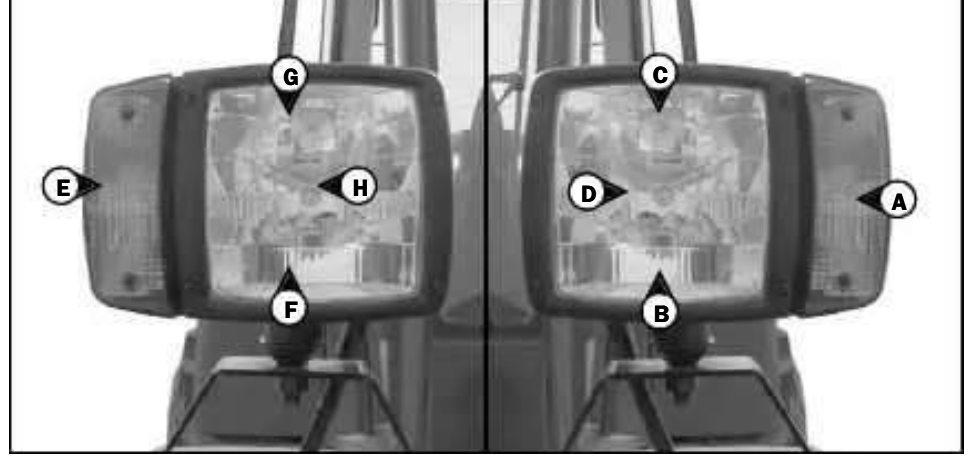

### **30 - REAR LIGHTS**

- A - Left rear indicator.
- B - Left rear stoplight.
- C - Left tail light.
- D - Left rear reverse light.
- E - Right rear reverse light.
- F - Right tail light.
- G - Right rear stoplight.
- H - Right rear indicator.

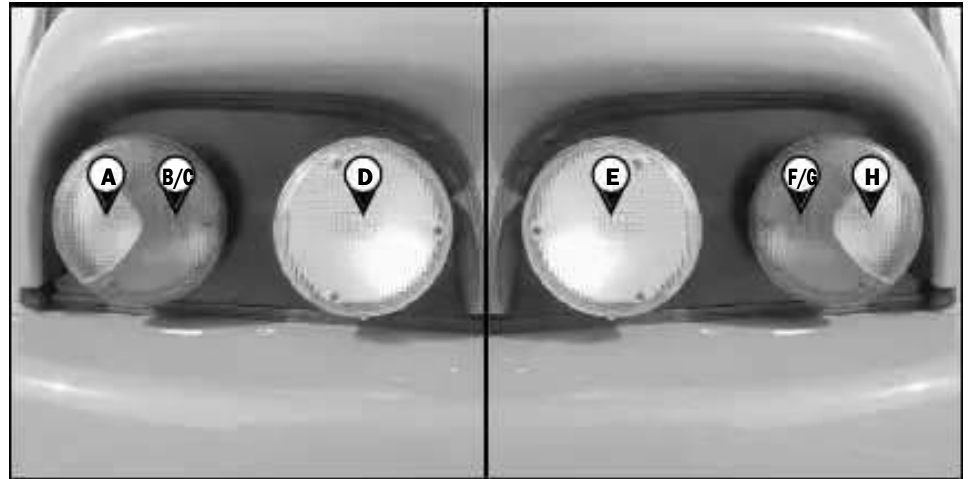

### **31 - REVOLVING LIGHT**

The revolving light pivots for space-saving on the lift truck and can be detached to prevent theft.

- Loosen nut 1 and remove the revolving light.
- Protect mounting 2 with cap 3.



### **32 - FRONT WORKING TAIL LIGHT**



### **33 - REAR WORKING TAIL LIGHT**



### **34 - REAR REFLECTORS**

---

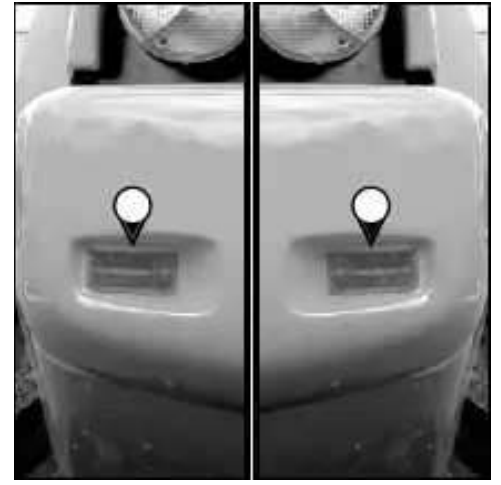

### **35 - STEERING WHEEL REGULATING HANDLE**

---

This handle enables the angle and height of the steering wheel to be adjusted.

- Turn handle 1 towards A to loosen and adjust steering wheel.
- Turn handle 1 towards B to lock steering wheel in the position required.

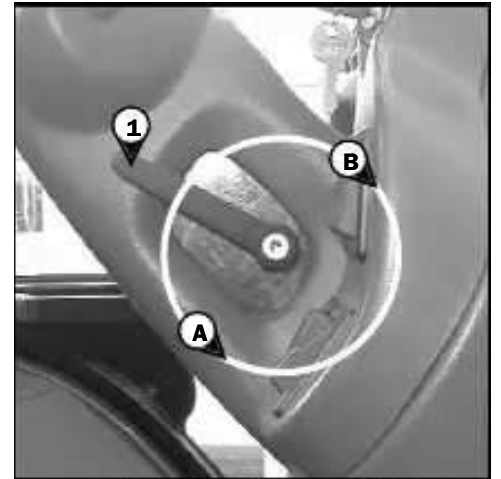

### **37 - DIAGNOSTIC CONNECTOR**

---



2 - 26

## **CONTENTS**

### **37 - REAR ELECTRIC SOCKET**

---

Enables power supply connection for a trailer (see : 2 - DESCRIPTION : TOWING PIN AND HOOK) or signalling bar.

- A - Left rear indicator.
- C - Earth.
- D - Right rear indicator.
- E - Right tail light.
- F - Rear stoplight.
- G - Left tail light.

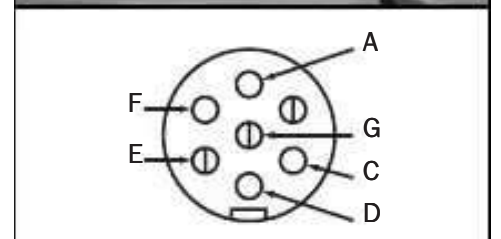
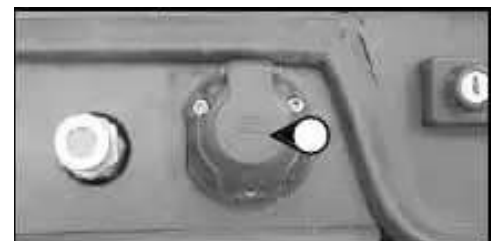



## TOWING PIN AND HOOK

Located at the rear of the lift truck, this device is used to attach a trailer. Its capacity is limited for each lift truck by the gross vehicle weight, tractive effort and maximum vertical force on the coupling point. This information is given on the manufacturer's plate fixed to each lift truck (see : 2 - DESCRIPTION : IDENTIFICATION OF THE LIFT TRUCK).

- To use a trailer, see current regulations in your country (maximum running speed, braking, maximum weight of trailer, etc.).
- Verify the trailer's condition before using it (tire condition and pressures, electrical connection, hydraulic hose, braking system...).

**WARNING**

*Do not tow a trailer or accessory which is not in proper working order. Using a trailer in poor condition may effect the lift truck's steering, braking, and safety.*



**WARNING**

*If a third party helps in coupling or uncoupling the trailer, they must be continually visible to the driver until the lift truck is parked and the I.C. engine is turned off.*

NOTE : There is an OPTIONAL rear-view mirror which allows the lift truck to be directed more closely to the trailer ring.

### COUPLING AND UNCOUPLING THE TRAILER

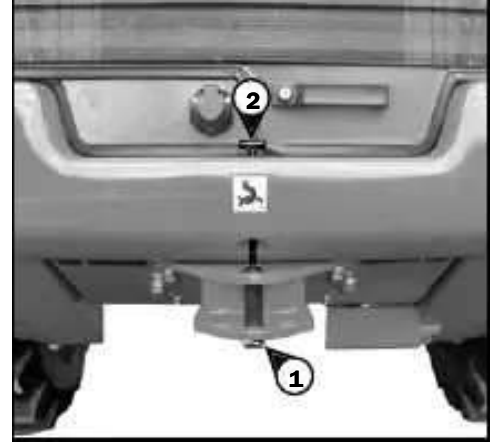
- To couple the trailer, position the lift truck as close as possible to the trailer ring.
- Put the handbrake on and switch off the I.C. engine.
- Remove the clip 1, lift the trailer pin 2 and place or remove the trailer ring.



#### WARNING

*Risk of crushed fingers or hands! Keep hands and fingers clear while coupling the trailer! The safety clip 1 must be installed after coupling. Before uncoupling, make sure the trailer is blocked in place and independently supported.*

### **B - HYDRAULIC TRAILER HOOK (OPTION)**

NOTE : The rear-view mirror OPTION is mandatory with the hydraulic trailer tow hook.

- Raise the hydraulic tow hook to release the hook lock 1 by pressing the upper part of switch 2.
- Pull the knob 3, retain this position and press the lower part of switch 2 to lower the tow hook.
- Release knob 3.
- Couple or uncouple the trailer.



#### WARNING

*When uncoupling, make sure that the trailer is supported independently.*

- Raise the trailer hook by pressing the upper part of switch 2 and then lower the hook to verify that the hook 4 lock is in proper contact with hook 1 lock.



#### WARNING

*Never use the tow hook to raise the rear of the lift truck (when changing the rear wheel for example).*

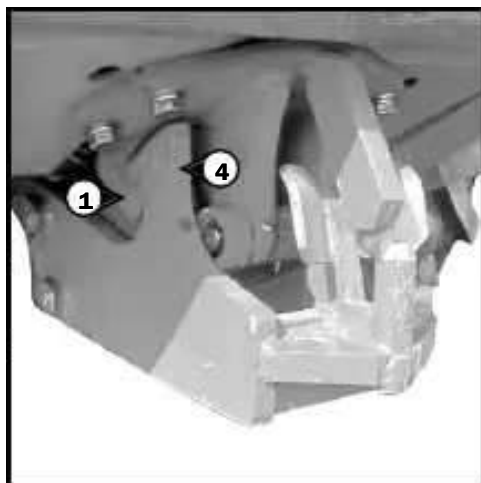

2 - 28

## CONTENTS

### **C - ELECTRICAL CONNECTION (STANDARD)**

- Connect the male plug to the female socket 1 on the lift truck and make sure the trailer lights work properly.

### **D - CONNECTING THE BRAKING SYSTEM (OPTION)**

- Connect the brake hose to the provided brake unit 2 on the lift truck.
- Make sure the trailer brakes are working properly and test the effects of braking before taking the trailer onto the public highway.

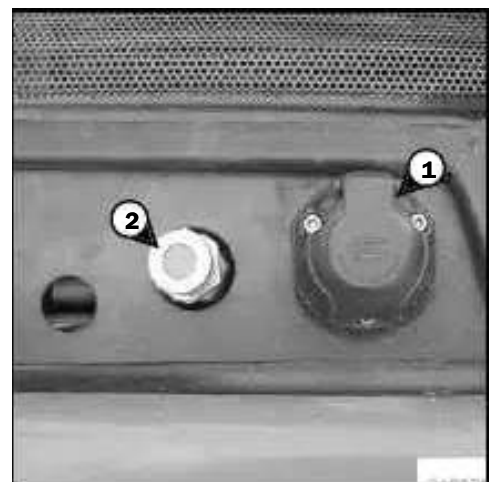

**CONTENTS**

**DESCRIPTION AND USE OF ELECTRIC AND HYDRAULIC OPTIONS**

**1 - REVERSE BUZZER (BACKUP) ALARM**

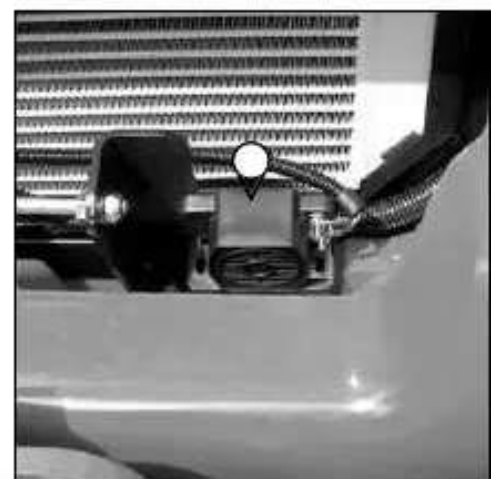

**2 - NUMBER PLATE**

**3 - NUMBER PLATE LIGHTING**

<https://www.forkliftpdfmanuals.com/>





#### **4 - PREHEATING ROD**

Enables the motor unit to be kept warm during prolonged periods of stoppage and thus, ensures the improved start-up of the I.C. engine.

**SUPPLY CHARACTERISTICS OF PREHEATING SYSTEM :**

- Rated range of power : 110-120V ; 50-60Hz
- Current consumed : 4,5A
- Equipment in class 1
- Category of insulation 2

**ENVIRONMENTAL CONDITIONS IN USE :**

- Maximum ambient temperature for using preheating : 77° F
- Pollution level 2

**CONDITIONS FOR CONNECTION AND USE OF PREHEATING :**

- The preheating system should not be used for an external ambient temperature higher than 77° F.
- It is essential that the power supply to the preheating system is :
  - Effected with a cable that conforms to the installation standards in force and contains a protective earth conductor.
  - Contains an appropriate sectioning system.
  - Incorporates an appropriate safety system against short circuits (fuses or circuit breaker) and a differential circuit breaker with 30mA sensitivity.
- Only connect to and disconnect from the power supply while the unit is off and the I.C. engine is stopped.

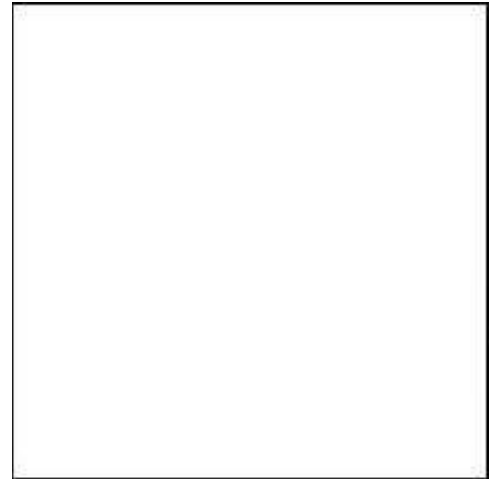

#### **5 - ELECTRIC SOCKET 12V**

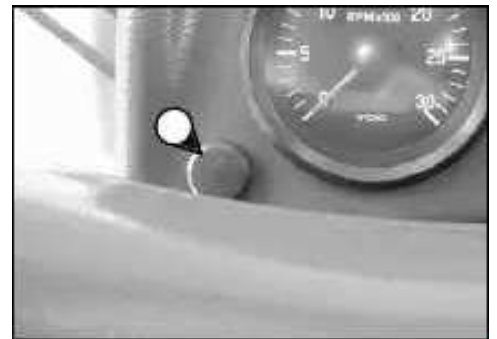

2 - 30

## **CONTENTS**

#### **6 - ELECTRICAL BOOM PROVISION**

Enables an electrical function to be used at the head of the boom.

**FUNCTIONING**

**MLA 628 -120 LSU POWERSHIFT Series 3-E2**

- Hold button 1 down and move button 2 up or down.
- NOTE : Switch 3 enables the function controlled by button 1 to be locked. Indicator 4 lights up to show when it is in use.



#### **7 - HYDRAULIC ATTACHMENT LOCKING** <https://www.forkliftpdfmanuals.com/>



Enables attachment locking to be controlled on the carriage and the use of a hydraulic attachment on the same hydraulic circuit (see : 4 - ADAPTABLE ATTACHMENTS IN OPTION ON THE RANGE : PICKING UP THE ATTACHMENTS).

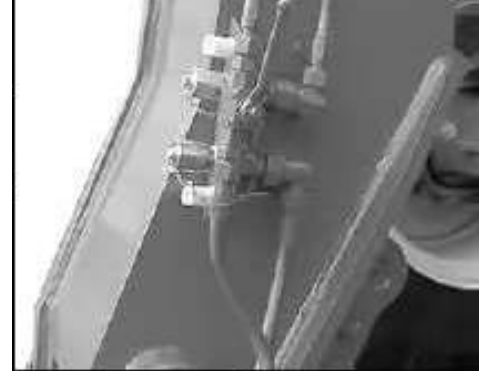

## **8 - BOOM HEAD ELECTROVALVE**

Enables use of two hydraulic functions on the attachment circuit.

<b>IMPORTANT</b>	<i>To make connection to the connectors easier, decompress the hydraulic circuit by pressing button 1 on the electrovalve.</i>
------------------	--

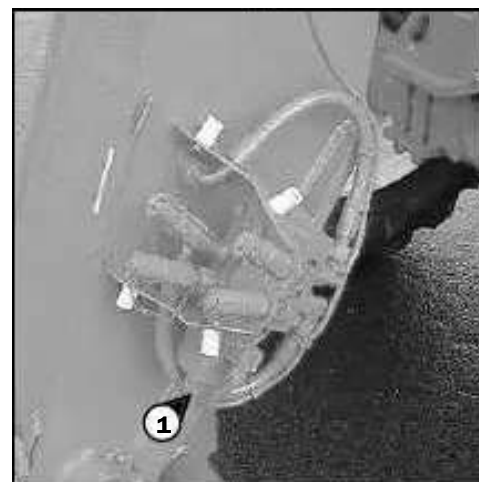

2 - 31

## **CONTENTS**

### **FUNCTIONING**

#### **MLA 628 -120 LSU POWERSHIFT Series 3-E2**

- Button 1 not engaged, button 2 controls a hydraulic function.
- Hold button 1 down, button 2 controls another hydraulic function.

NOTE : Switch 3 enables the hydraulic function controlled by button 1 to be locked. Indicator 4 lights up to show when it is in use.



## **9 - BOOM HEAD ELECTROVALVE + PREARRANGED HYDRAULIC ATTACHMENT LOCKING**

The addition of these two options enables the combining of several hydraulic functions.





## **10 - PREARRANGED TRAILER LOCKING**

Enables the hydraulic connection of a braked trailer (see : 2 - DESCRIPTION : TOWING PIN AND HOOK).



2 - 32

## **CONTENTS**

## **11 - DUAL EFFECT REAR HYDRAULIC CONTROL PREDISPOSITION**

Enables the use of a hydraulic accessory at the rear of the lift truck (e.g. a trailer with hydraulic tipping).

### **FUNCTIONING**

- Switch 1 controls this predisposition.



## 12 - BOOM SUSPENSION

The boom is suspended to reduce shaking of the lift truck on rough ground (e.g. moving straw in a field).

### FUNCTIONING

- Set the forks or attachment on the ground and relieve some of the load from the front wheels.
- Press switch A set to position A1, the visual indicator comes on indicating that boom suspension is activated.
- Press switch A set to position A2, the visual indicator goes out indicating that boom suspension is deactivated.



### IMPORTANT

Boom suspension is active to a lifting height of 9.8 feet from the axis of articulation of the carriage with respect to the ground with the boom retracted. When you move beyond this height or make another hydraulic movement (tilting, telescoping, attachment), boom suspension is momentarily deactivated and the visual indicator of switch A goes out.

- When the I.C. engine is off, boom suspension is automatically deactivated.

2 - 33

## CONTENTS

## 13 - ATTACHMENT HYDRAULIC CONTROL FORCED OPERATION

MLA 628 -120 LSU POWERSHIFT Series 3-E2

 <b>WARNING</b>	<i>This OPTION must only be used with an attachment requiring continuous hydraulic movement : brush, supply bucket, mixer, spray... It is strictly forbidden in handling operations and all other operations (winch, crane boom, crane boom with winch, hook, etc.).</i>
--	--

### CONTINUOUS HYDRAULIC MOVEMENT OF THE ATTACHMENT

- Make sure the potentiometer C is set to 0 %.
- Switch button A up or down (depending on the type of attachment), press button B and release button A. The red indicator 1, flashes to indicate that it is in operation.
- Set the required flowrate using potentiometer C.
- To stop continuous hydraulic movement of the attachment, switch button A up or down or press button B. Indicator 1 goes out.
- Set potentiometer C to 0 %.

 <b>WARNING</b>	<i>Never leave the driver's cab without resetting the potentiometer C to 0 %. Before starting the lift truck, make sure the potentiometer is set to 0 %.</i>
--	--





2 - 34

CONTENTS

# **3 - MAINTENANCE**



**3 - 1**

**CONTENTS**

**CONTENTS**

**TABLE OF CONTENTS**

<b><i>MANITOU ORIGINAL SPARE PARTS AND EQUIPMENT</i></b>	<b>3 - 5</b>
<b><i>FILTERS CARTRIDGES AND BELTS</i></b>	<b>3 - 7</b>
<b><i>LUBRICANTS AND FUEL</i></b>	<b>3 - 8</b>
<b><i>SERVICING SCHEDULE</i></b>	<b>3 - 10</b>
<b><i>A - DAILY OR EVERY 10 HOURS SERVICE</i></b>	<b>3 - 12</b>
<b><i>B - EVERY 50 HOURS SERVICE</i></b>	<b>3 - 16</b>

<b>C - EVERY 250 HOURS SERVICE</b>	<b>3 - 22</b>
<b>D - EVERY 500 HOURS SERVICE</b>	<b>3 - 24</b>
<b>E - EVERY 1000 HOURS SERVICE</b>	<b>3 - 30</b>
<b>F - EVERY 2000 HOURS SERVICE</b>	<b>3 - 34</b>
<b>G - OCCASIONAL MAINTENANCE</b>	<b>3 - 36</b>
<b>H - EVERY TWO YEARS (OPTION AIR CONDITIONING)</b>	<b>3 - 40</b>

## **MANITOU ORIGINAL SPARE PARTS AND EQUIPMENT**

**OUR LIFT TRUCKS MUST BE SERVICED USING ORIGINAL MANITOU PARTS.**

***IF YOU USE PARTS WHICH ARE NOT ORIGINAL MANITOU PARTS,***

---

**YOU RISK**

- Legally - to be held responsible in the event of an accident.

- Technically - to generate operating failure or shorten the life of the lift truck.

**THE USE OF COUNTERFEIT PARTS OR COMPONENTS NOT APPROVED BY THE MANUFACTURER,  
MEANS YOU LOSE THE BENEFIT OF THE CONTRACTUAL GUARANTEE.**

***BY USING ORIGINAL MANITOU PARTS FOR MAINTENANCE OPERATIONS,***

---

**YOU BENEFIT  
EXPERTISE**

**THROUGH ITS NETWORK, MANITOU PROVIDES THE USER WITH**

- Know-how and competence. <https://www.forkliftpdfmanuals.com/>

- The guarantee of high-quality work.
- Original replacement components.
- Help with preventive maintenance.
- Efficient help with diagnosis.
- Improvements due to experience feedback.
- Operator training.
- Only the MANITOU network has detailed knowledge of the design of the lift truck and therefore the best technical ability to provide maintenance.

**ORIGINAL REPLACEMENT PARTS ARE DISTRIBUTED EXCLUSIVELY BY MANITOU AND ITS DEALER NETWORK.**

**3 - 5**

**CONTENTS**

**CONTENTS**

**FILTERS CARTRIDGES AND BELTS**

**MLA 628 -120 LSU POWERSHIFT Series 3-E2**

**I.C. ENGINE**

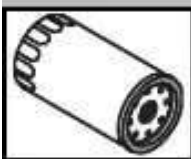

I.C. ENGINE OIL FILTER  
Part number : 476954  
Change : 500 H



ALTERNATOR BELT  
Part number : 773722



DRY AIR FILTER CARTRIDGE  
Part number : 563416  
Clean : 50 H\*  
Change : 500 H\*

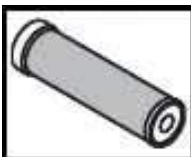

SAFETY DRY AIR FILTER CARTRIDGE  
Part number : 563415  
Change : 1000 H\*



CYCLONIC PRE-FILTER  
Part number : 224713  
Clean : 10 H



FUEL FILTER CARTRIDGE  
Part number : 605013

Change : 500 H

\* : This schedule is given for information only (see : 3 - MAINTENANCE : SERVICING SCHEDULE) for cleaning and changing.

### TRANSMISSION



TRANSMISSION OIL FILTER  
Part number : 550145  
Change : 500 H

### HYDRAULICS



HYDRAULIC RETURN OIL FILTER CARTRIDGE  
Part number : 485696  
Change : 500 H



SUCTION STRAINER FOR HYDRAULIC OIL TANK  
Part number : 224726  
Clean : 1000 H



FILTER CAP FOR HYDRAULIC OIL TANK  
Part number : 62415  
Change : 1000 H

### BRAKE



BRAKING PRESSURE OIL FILTER CARTRIDGE  
Part number : 705922  
Change : 500 H

### CAB

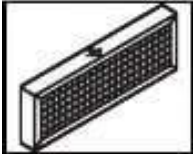

CAB VENTILATION FILTER (WITHOUT AIR CONDITIONING)  
Part number : 603747 (Qty: 2)  
Clean : 500 H



CAB VENTILATION FILTER (WITH AIR CONDITIONING)  
Part number : 603747 (Qty: 1)  
Clean : 50 H  
Change : 250 H

## CONTENTS

## LUBRICANTS AND FUEL

- For topping up, oils may not be miscible.
- For oil changes, MANITOU oils are perfectly appropriate.

### DIAGNOSTIC ANALYSIS OF OILS

If a service or maintenance contract has been organized with the dealer, a diagnostic analysis of engine, transmission and axle oils may be requested depending on the rate of use.

### (\*) FUEL CHARACTERISTICS

Use a high-quality fuel to obtain optimal performance of the I.C. engine.

#### CHARACTERISTICS OF RECOMMENDED FUEL :

- Types of diesel N590 - Auto/C0/C1/C2/C3/C4
- BS2869 Class A2
- ASTM D975 - 91 Class 2D
- JIS K2204 (1992) Grades 1, 2, 3 and Special Grade 3.

COMPONENT	CAPACITY	RECOMMENDATION		
I.C. ENGINE	8,5 Liters (2.2 gal)	Shell: Rotella 15w40 Citgo: C-600 15w40		
COOLING CIRCUIT	20 Liters	Tulco 50/50 Premix Anti-freeze		
FUEL TANK	117 Liters (30.9 gal)	Diesel fuel (*)		

TRANSMISSION				
COMPONENT	CAPACITY	RECOMMENDATION		
TRANSMISSION	16 Liters (4.2 gal)	Shell: Donax TG Dexron III Citgo: Transgard ATF Dexron III		
TRANSMISSION UNIVERSAL JOINT		Shell: Rentinax Am Citgo: Lithoplex CM-2		

BOOM				
COMPONENT	CAPACITY	RECOMMENDATION		
BOOM PADS		Shell: Rentinax Am Citgo: Lithoplex CM-2		
GREASING OF THE BOOM		Shell: Rentinax Am Citgo: Lithoplex CM-2		

**CONTENTS**

HYDRAULICS				
COMPONENT	CAPACITY	RECOMMENDATION		
HYDRAULIC OIL TANK	130 Liters (34.3 gal)	Shell: Tellus T46 Citgo: Transgard THF Lo-Temp		

BRAKE				
COMPONENT	CAPACITY	RECOMMENDATION		
BRAKE CIRCUIT		Shell: Donax TG Dexron III Citgo: Transgard ATF Dexron III		

CAB				
COMPONENT	CAPACITY	RECOMMENDATION		
CAB DOOR		Shell: Rentinax Am Citgo: Lithoplex CM-2		
WINDSCREEN WASHER TANK		<a href="https://www.forkliftmanuals.com/">https://www.forkliftmanuals.com/</a> Windscreen washer fluid		



FRONT AXLE				
COMPONENT	CAPACITY	RECOMMENDATION		
FRONT AXLE DIFFERENTIAL*	6,8 Liters (1.8 gal)	Shell: Donax TD Citgo: Transgard Tractor Hyd Fluid		
FRONT WHEELS REDUCERS	0,75 Liter (0.8 qts)	Shell: Spirax DH80w90 Citgo: Premium Gear MP 80w90		

REAR AXLE				
COMPONENT	CAPACITY	RECOMMENDATION		
REAR AXLE DIFFERENTIAL*	6,9 Liters (1.8 gal)	Shell: Donax TD Citgo: Transgard Tractor Hyd Fluid		
REAR WHEELS REDUCERS	0,75 Liter (0.8 qts)	Shell: Spirax DH80w90 Citgo: Premium Gear MP 80w90		
REAR AXLE OSCILLATION		Shell: Rentinax Am Citgo: Lithoplex CM-2		

CHASSIS				
COMPONENT		RECOMMENDATION		
ARTICULATION OF THE CHASSIS		Shell: Rentinax Am Citgo: Lithoplex CM-2		
STEERING CYLINDER		Shell: Rentinax Am Citgo: Lithoplex CM-2		

\* First 200 hrs: Use Manitou Special Immersed Brakes 549 Lubricant. (5 gal. drum, p/n: 545608)

**CONTENTS**

**SERVICING SCHEDULE**

<b>A = AJUST</b>	<b>N = CLEAN</b>
<b>C = CHECK</b>	<b>P = BLEED</b>
<b>D = DESCALE</b>	<b>R = CHANGE</b>
<b>G = GREASE</b>	<b>V = DRAIN/CHANGE</b>

After the first 50 hours	Day or 10 hours	50 hours	250 hours	1 year or 500 hours	1 year or 1000 hours	2000 hours	4000 hours
--------------------------	-----------------	----------	-----------	---------------------	----------------------	------------	------------

**I.C. ENGINE**

I.C. engine oil level	C	←←	←←	←←	←←	←←	←←
Cooling liquid level	C	←←	←←	←←	←←	←←	←←
Fuel level	C	←←	←←	←←	←←	←←	←←
Cyclonic prefilter	N	←←	←←	←←	←←	←←	←←
Dry air filter cartridge		N	←←	R	←←	←←	←←
Radiator core		N	←←	←←	←←	←←	←←
Condenser core (OPTION Air conditioning)		N	←←	←←	←←	←←	←←
Alternator/crankshaft belt tension	A		A	←←	←←	←←	←←
Compressor belt tension (OPTION Air conditioning)			A	←←	←←	←←	←←
I.C. engine oil	V			V	←←	←←	←←
I.C. engine oil filter	R			R	←←	←←	←←
Fuel filter cartridge	R			R	←←	←←	←←
Fuel tank					N	←←	←←
Safety dry air filter cartridge					R	←←	←←
I.C. engine silent blocks					C**	←←	←←

I.C. engine rates	C**	<<	<<
Valves clearances	C**	<<	<<
Cooling liquid	V	<<	<<
Radiator	N/D**	<<	<<
Water pump and the thermostat	C**	<<	<<
Alternator and the starter motor	C**	<<	<<
Turbocompressor	C**	<<	<<
Bleed the fuel system			

**TRANSMISSION**

Transmission oil level	C	<<	<<	<<	<<	<<	<<
Transmission universal joint	G	<<	<<	<<	<<	<<	G/C**
Transmission oil filter	R			R	<<	<<	<<
Transmission oil blocks	V				CV*	<<	<<
Transmission controls					C**	<<	<<
Transmission pressures					C**	<<	<<
Converter pressure					C**	<<	<<

**TIRES**

Tires pressure	C	<<	<<	<<	<<	<<	<<
Wheel nuts torque	C	<<	<<	<<	<<	<<	<<
Condition of wheels and tires					C**	<<	<<
Change a wheel							

**BOOM**

Boom pads	G*						
Boom	G	<<	<<	<<	<<	<<	<<
Boom pads wear					C**	<<	<<
Condition of boom unit					C**	<<	<<
Bearings and articulation rings					C**	<<	<<

**HYDRAULICS**

Hydraulic oil level	C	<<	<<	<<	<<	<<	<<
Hydraulic return oil filter cartridge	R			R	<<	<<	<<
Balancing valve	C			C	<<	<<	<<
Hydraulic oil					V	<<	<<
Suction strainer for hydraulic oil tank					N	<<	<<
Filter cap for hydraulic oil tank					R	<<	<<
Speeds of hydraulic movements					C**	<<	<<
Hydraulic pump pipe filter					N**	<<	<<
Condition of hoses and flexibles pipes					C**	<<	<<
Condition of cylinders (leakage, shafts)					C**	<<	<<
Hydraulic circuit pressures					C**	<<	<<
Hydraulic circuit outputs					C**	<<	<<
Hydraulic oil tank					N**	<<	<<

3 - 10

**CONTENTS**

<b>A = AJUST</b>	<b>N = CLEAN</b>
<b>C = CHECK</b>	<b>P = BLEED</b>
<b>D = DESCALE</b>	<b>R = CHANGE</b>
<b>G = GREASE</b>	<b>V = DRAIN/CHANGE</b>

After the first 50 hours	Day or 10 hours	50 hours	250 hours	1 year or 500 hours	1 year or 1000 hours	2000 hours	4000 hours
--------------------------	-----------------	----------	-----------	---------------------	----------------------	------------	------------

**BRAKE**

Parking brake	C/A	<<	<<	<<	<<	<<	<<
Parking brake lever mechanism				G	<<	<<	<<
Braking pressure oil filter cartridge	R			R	<<	<<	<<
Brake oil					V**	<<	<<
Brake circuit					P**	<<	<<
Brake circuit pressure					C**	<<	<<
Brake					A**	<<	<<

**STEERING**

Steering cylinder	G	<<	<<	<<	<<	<<	<<
Steering swivel joints					C**	<<	<<

**CAB**

Windscreen washer liquid level	C	<<	<<	<<	<<	<<	<<
Cab door	G	<<	<<	<<	<<	<<	<<
Cab ventilation filter (OPTION Air conditioning)	N	R	<<	<<	<<	<<	<<
Cab ventilation filter				N	<<	<<	<<
Seat belt					C	<<	<<
Condition of the rear view mirrors					C**	<<	<<

Structure ..... **C\*\*** << << << << <<  
 OPTION Air conditioning .....

**ELECTRICITY**

Battery electrolyte level ..... **C** << << << << <<  
 Battery electrolyte density ..... **C** << << << <<  
 Condition of wiring harness and cables ..... **C\*\*** << <<  
 Lights and signals ..... **C\*\*** << <<  
 Warning indicators ..... **C\*\*** << <<  
 Adjust the front headlamps .....

**FRONT AXLE**

Front axle differential oil level ..... **C** << << << <<  
 Front wheels reducers oil level ..... **C** << << << <<  
 Front axle differential oil ..... **V** << << << <<  
 Front wheels reducers oil ..... **V** << << << <<  
 Wearing of front axle brake discs ..... **C\*\***  
 Front wheels reducers clearance ..... **C\*\***

**REAR AXLE**

Rear axle oscillation ..... **G** << << << **G/C\*\*** <<  
 Rear axle differential oil level ..... **C** << << << <<  
 Rear wheels reducers oil level ..... **C** << << << <<  
 Rear axle differential oil ..... **V** << << << <<  
 Rear wheels reducers oil ..... **V** << << << <<  
 Wearing of rear axle brake discs ..... **C\*\***  
 Rear wheels reducers clearance ..... **C\*\***

**CHASSIS**

Articulation axles of the chassis ..... **G** << << << **G/C\*\*** <<  
 Structure ..... **C\*\*** << <<  
 Bearings and articulation rings ..... **C\*\*** <<

**ATTACHMENTS**

Forks wear ..... **C\*\*** << << <<  
 Attachment carriage ..... **C\*\*** << <<  
 Condition of attachments ..... **C\*\*** << <<

**LIFT TRUCK**

Tow the lift truck .....  
 Sling the lift truck .....  
 Transport the lift truck on a platform .....

(\*) : Every 10 hours during the first 50 hours, then once at 250 hours.  
 (\*\*): Consult your dealer.

**CONTENTS**

**A - DAILY OR EVERY 10 HOURS SERVICE**

**A1 - I.C. ENGINE OIL LEVEL**

**CHECK**

Park the lift truck on level ground with the I.C. engine stopped, and let the oil drain into the sump.

- Open the I.C. engine cover.
- Remove the dipstick 1 (fig. A1).
- Wipe the dipstick and check the correct level at the upper mark.
- If necessary, add oil (see : 3 - MAINTENANCE : LUBRICANTS AND FUEL) by the filler port 2 (fig. A1).
- Check visually that there is no leakage or seepage of oil in the I.C. engine.

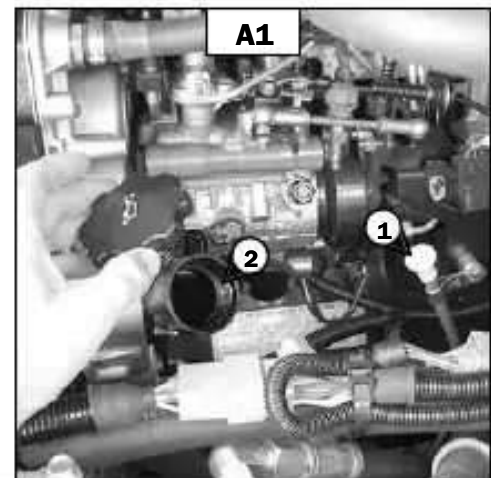

**A2 - COOLING LIQUID LEVEL**

**CHECK**

Park the lift truck on level ground with the I.C. engine stopped, and allow the I.C. engine



to cool.

- Open the I.C. engine cover.
- The liquid must be situated half way up the expansion pan 1 (fig. A2).
- If necessary, add cooling liquid (see : 3 - MAINTENANCE : LUBRICANTS AND FUEL) by the filler port 2 (fig. A2).



	<b>WARNING</b>	To avoid risk of spraying or burning, wait until the I.C. engine has cooled down before removing the radiator cap. If the cooling liquid is very hot, add only hot cooling liquid. In an emergency, you can use water as a cooling liquid, then change the cooling circuit liquid as soon as possible (see : 3 - MAINTENANCE : F1 - COOLING LIQUID).
--	----------------	--

### A3 - FUEL LEVEL

**CHECK**

Keep the fuel tank near full, to reduce as much as possible any condensation due to atmospheric conditions.

- Open the I.C. engine cover.
- Remove cap 1 (fig. A3).
- Fill the fuel tank with clean fuel (see : 3 - MAINTENANCE : LUBRICANTS AND FUEL ), filtered through a strainer or a clean, lint free cloth, through filler port 2 (fig. A3).
- Put the cap back 1 (fig. A3).
- Check visually that there is no leakage in the tank and pipes.

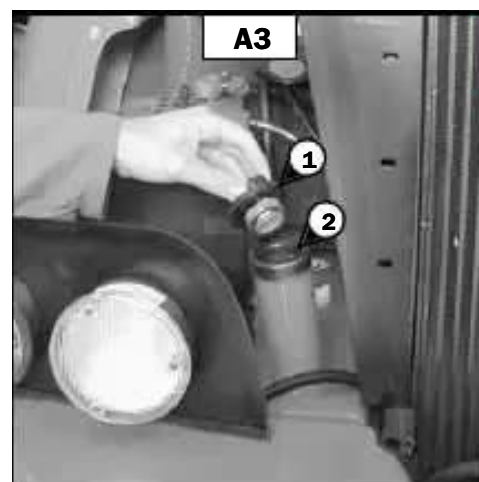

	<b>WARNING</b>	Never smoke or approach with a flame during filling operations or when the tank is open. Never refill while the I.C. engine is running.
--	----------------	---

	<b>WARNING</b>	The fuel tank is vented via the filler plug. When changing it, always use an original part, with vented hole.
--	----------------	---

## CONTENTS

### A4 - CYCLONIC PREFILTER

**CLEAN**

The cleaning interval is given as a guide, however the prefilter must be emptied as soon as impurities reach the MAXI level on the tank.

- Loosen nut 1 (fig. A4), remove cover 2 (fig. A4) and empty the tank.
- Clean the prefilter unit with a clean dry cloth and reassemble the unit.

<b>IMPORTANT</b>	When cleaning, take care not to let impurities into the dry air filter.
------------------	---

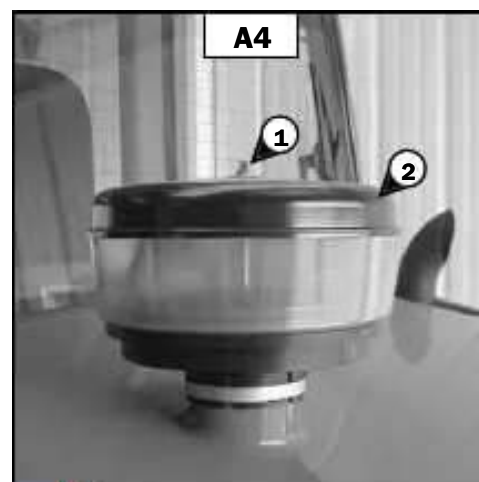

### A5 - TRANSMISSION OIL LEVEL

**CHECK**

Park the lift truck on level ground with the engine cold and at idle.

- For the minimum oil level, remove the screw 1 (fig. A5/1) and check that the oil flushes the port.
- If necessary, add oil <https://www.forkliftpdfmanuals.com/>
- Remove the cover plate 2 (fig. A5/2) and add oil (see : 3 - MAINTENANCE : LUBRICANTS AND FUEL).

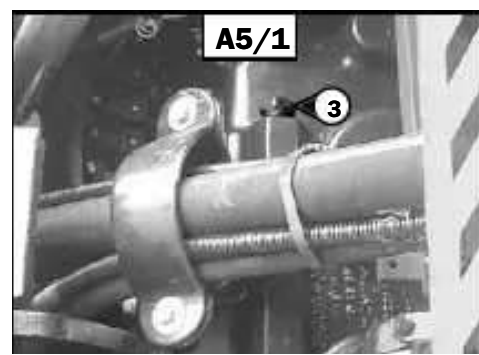

AND FUEL) by the filler port 3 (fig. A5/1).

NOTE : COLD LEVEL (between 59°F and 68°F)

The oil must be at its minimum, at the level of the screw 1 (fig. A5/1)

HOT LEVEL (between 180°F and 200°F)

The oil must be at the level of the screw 4 (fig. A5/1).

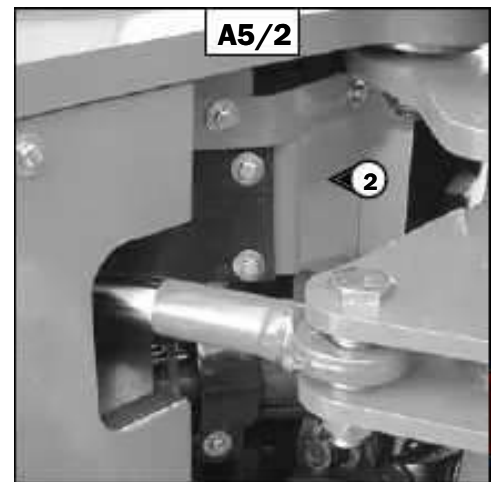
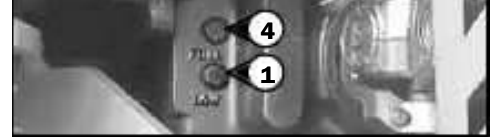

## **A6 - TIRES PRESSURE AND WHEEL NUTS TORQUE**

**CHECK**

- Check the condition of the tires, to detect cuts, wear, etc.
- Check the torque load of the wheel nuts. Non compliance with this instruction can cause damage and rupture to the wheel bolts and distortion to the wheels.
  - Wheel nuts tightening torque
    - Front tires : 465 ft/lb
    - Rear tires : 465 ft/lb
- Check and adjust the tire pressures if necessary (see : 2 - DESCRIPTION : CHARACTERISTICS).



### **WARNING**

Check that the air hose is correctly connected to the tire valve before inflating and keep all persons at a distance during inflation. Respect the recommended tire pressures given.

## **CONTENTS**

## **A7 - BOOM PADS**

**CLEAN - GREASE**

To be carried out every 10 hours during the first 50 hours service, then once at 250 hours.

- Extend the boom completely.
- With a brush, apply a coat of grease (see : 3 - MAINTENANCE : LUBRICANTS AND FUEL) on the 4 sides of the telescope(s) (fig. A7).
- Telescope the boom several times in order to spread the coat of grease evenly.
- Remove the surplus of grease.

### **IMPORTANT**

If the lift truck is used in an abrasive environment (dust, sand, coal...) Use lubricating varnish, contact your dealer.

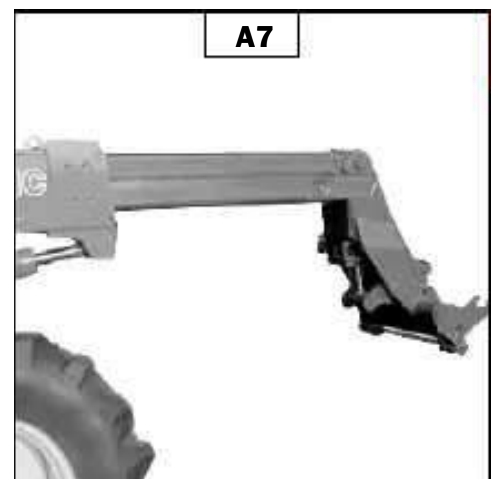

**3 - 14**

**CONTENTS**

## **B - EVERY 50 HOURS SERVICE**

*Carry out the operations described previously as well as the following operations.*

### **B1 - DRY AIR FILTER CARTRIDGE**

#### **CHECK - CLEAN**

In case of use in a heavily dust laden atmosphere, there are pre-filtration cartridges (see : 3 - MAINTENANCE : FILTERS CARTRIDGES AND BELTS). Also, the checking and cleaning schedule of the cartridge must be reduced.

#### **IMPORTANT**

*If the clogging indicator light comes on, this operation must be carried out as quickly as possible (1 hour maximum). The cartridge must not be cleaned more than seven times, after which the cartridge must be changed.*

- For the disassembly and reassembly of the cartridge, see : 3 - MAINTENANCE : D3 - DRY AIR FILTER CARTRIDGE.
- Clean the filter cartridge using a compressed air jet (max. pressure 40 psi) directed from the top to the bottom and from the inside towards the outside at a distance no less than 1 in. from the cartridge wall.
- Cleaning is completed when there is no more dust on the cartridge.

#### **IMPORTANT**

*Avoid tearing or making a hole in the cartridge. The cartridge must not be blown anywhere near the air filter box. Never clean the cartridge by tapping it against a hard surface. Your eyes must be protected during this intervention.*

- Clean the cartridge seal surfaces with a damp, clean lint-free cloth and grease with a silicone lubricant.

- Check visually the outer condition of the air filter and its mounts. Verify the condition of the hoses and their mounts also.

**IMPORTANT**

*Do not clean the dry air filter cartridge by washing in liquid. Do not clean the safety cartridge located inside the filter cartridge, change it for a new one if it is dirty or damaged.*

**B2 - RADIATOR CORE****CLEAN****IMPORTANT**

*In a heavy dust atmosphere, clean the radiator core every day. Do not use a water jet or high-pressure steam as this could damage the radiator fins.*

- Open the I.C. engine cover.
- In order to prevent the radiator becoming clogged, clean the radiator with a compressed air jet directed from inside to outside. This is the only way to clean the core of debris.
- If necessary, clean the suction grid on the engine cover.

**B3 - CONDENSER CORE (OPTION AIR CONDITIONING)****CLEAN****IMPORTANT**

*In a heavy dust atmosphere, clean the radiator core every day. Do not use a water jet or high-pressure steam as this could damage the radiator fins.*

- Open the I.C. engine cover.
- Loosen the knurled screws 1 (fig. B3/1) and swing around the filter and condenser unit.
- Clean the core with a blast of compressed air aimed from the inside towards the outside (fig. B3/2). This is the most effective way of removing the impurities.

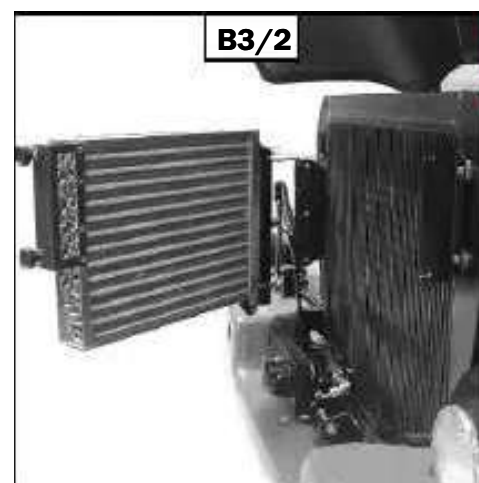
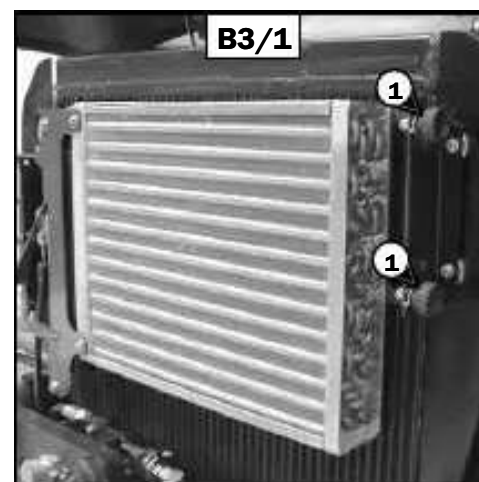
**3 - 16****CONTENTS****B4 - Boom**

To be carried out weekly, if the lift truck has been operated for less than 50 hours during the week.

**GREASE****IMPORTANT**

*In the event of prolonged use in an extremely dusty or oxidising atmosphere, reduce this interval to 10 working hours or every day.*

Clean and lubricate the following points with grease (see : 3 - MAINTENANCE : LUBRICANTS AND FUEL) and remove the surplus of grease.

- 1 - Lubricators of the boom axle (2 lubricators) (fig. B4/1).
- 2 - Lubricators of the carriage axle (2 lubricators) (fig. B4/2).
- 3 - Lubricator of the tilt cylinder foot axle (1 lubricator) (fig. B4/3).
- 4 - Lubricator of the tilt cylinder head axle (1 lubricator) (fig. B4/4).
- 5 - Lubricators of the carriage connecting rod axle (3 lubricators) (fig. B4/2 and B4/4).
- 6 - Lubricator of the lifting cylinder foot axle (1 lubricator) (fig. B4/5).
- 7 - Lubricator of the lifting cylinder head axle (1 lubricator) (fig. B4/6).
- 8 - Lubricator of the compensation cylinder foot axle (1 lubricator) (fig. B4/5).
- 9 - Lubricator of the compensation cylinder head axle (1 lubricator) (fig. B4/6).



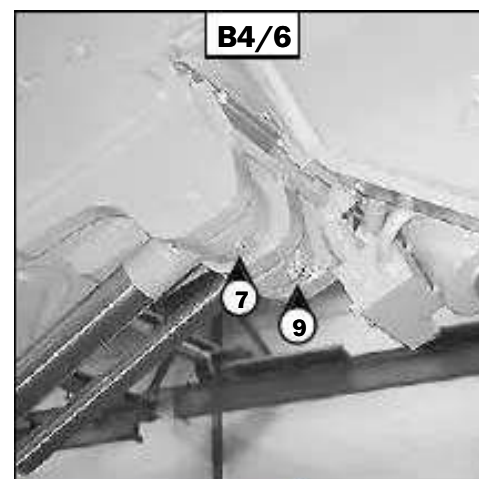
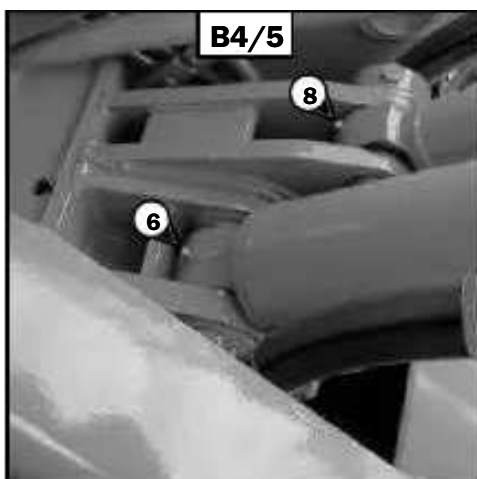
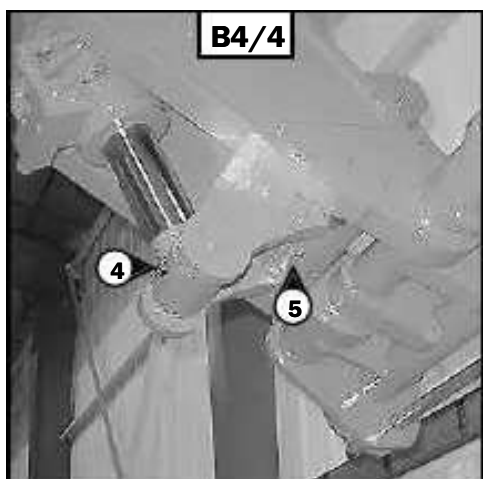
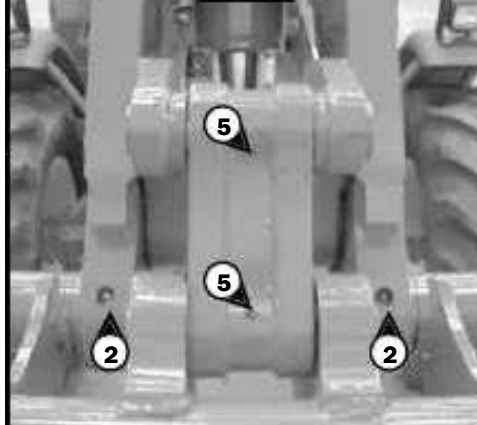
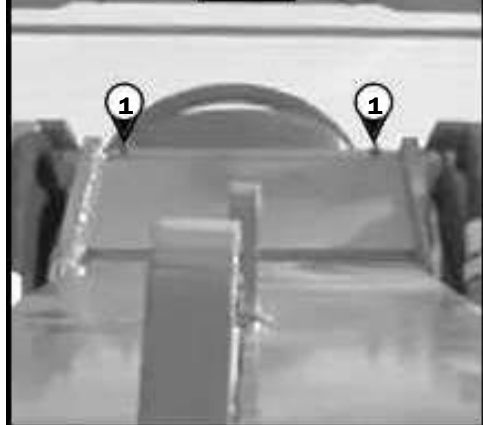

### **B5 - HYDRAULIC OIL LEVEL**

**CHECK**

Park the lift truck on level ground with the I.C. engine stopped, and the boom retracted and lowered as far as possible.

- Refer to gauge 1 (fig. B5).
- The oil level is correct when it is at the level of the red point.
- If necessary, add oil (see : 3 - MAINTENANCE : LUBRICANTS AND FUEL).
- Remove cap 2 (fig. B5).
- Add oil by filler port 3 (fig. B5).

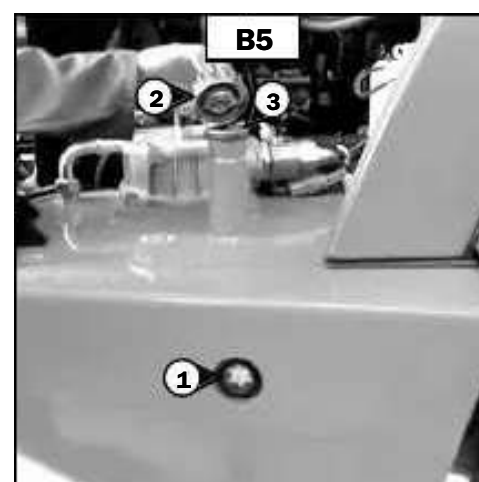

**IMPORTANT**

*Use a clean funnel and clean the oil nozzle before filling.*

- Put the cap back.
- Check visually that there is no leakage in the tank and pipes.

Always maintain the oil level at maximum as cooling depends on the oil flowing through the tank.

**CONTENTS**

### **B6 - WINDSCREEN WASHER LIQUID LEVEL**

**CHECK**

- Open the I.C. engine cover.
- Check visually the level.
- If necessary add windscreen washer liquid (see : 3 - MAINTENANCE : LUBRICANTS AND FUEL) by filler port 1 (fig. B6).

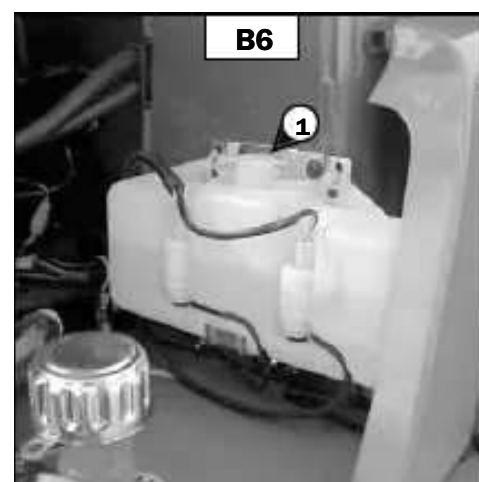

### **B7 - CAB DOOR**

**GREASE**

Clean and lubricate the points 1 (4 lubricators) (fig. B7) with grease (see : 3 - MAINTENANCE : LUBRICANTS AND FUEL) and remove the surplus grease.

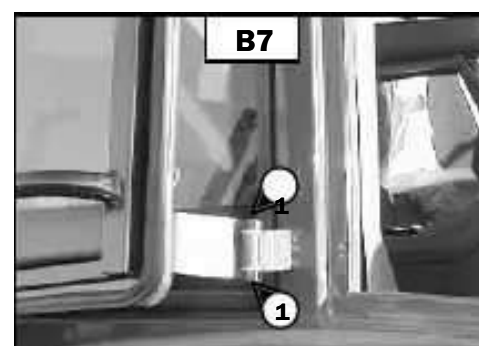

## **B8 - CAB VENTILATION FILTER (OPTION AIR CONDITIONING)**

**CLEAN**

- Lift up protective casing 1 (fig. B8).
- Lift out cabin ventilation filter 2 (fig. B8).
- Clean the filter with a compressed air jet.
- Check its condition and change if necessary (see : 3 - MAINTENANCE : FILTERS CARTRIDGES AND BELTS).
- Install the filter and protective casing.

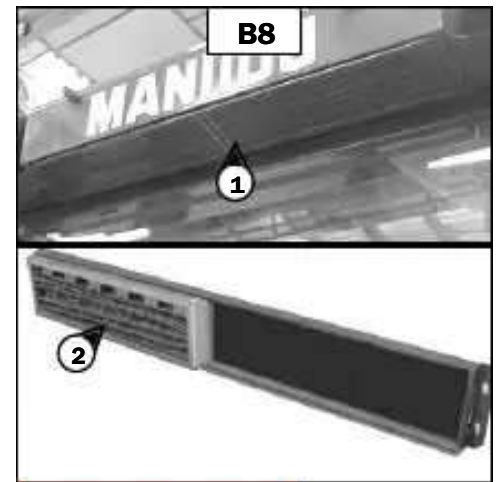



## **B9 - BATTERY ELECTROLYTE LEVEL**

**CHECK**

Check the electrolyte level in each cell of the battery.  
If the lift truck is working in a high temperature environment, check the level more frequently than every 50 hours service.

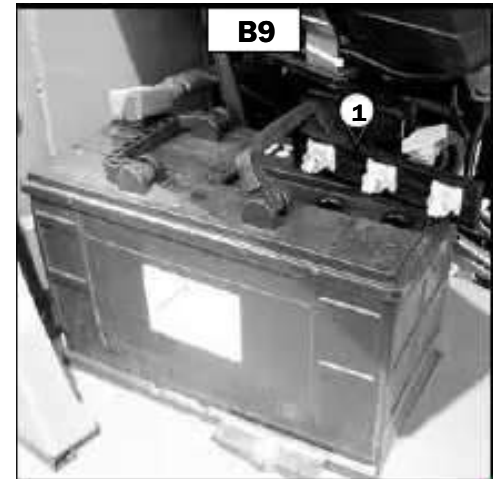
- Open the I.C. engine cover.
- Remove caps 1 (fig. B9) from each cell of the battery.
- The level is correct when it is 1/2 in. above the top of the plates in the battery.
- If necessary, top up the cells with clean distilled water that has been stored in a glass container.
- Clean and dry caps 1 (fig. B9) and install.
- Check the terminal connections and lightly smear them with petroleum jelly to prevent the formation of corrosion.



 <b>WARNING</b>	<p>Handling and servicing a battery can be dangerous, take the following precautions :</p> <ul style="list-style-type: none"><li>- Wear protective goggles.</li><li>- Keep the battery horizontal.</li><li>- Never smoke or work near an open flame.</li><li>- Work in a well-ventilated area.</li><li>- In the event of electrolyte being spilled onto the skin or splashed in the eyes, rinse thoroughly with cold water for 15 minutes and call a doctor.</li></ul>
---	--

**3 - 18**

## **CONTENTS**

## **B10 - REAR AXLE OSCILLATION**

**GREASE**

Clean and lubricate the points 1 (2 lubricators) (fig. B10) with grease (see : 3 - MAINTENANCE : LUBRICANTS AND FUEL) and remove the surplus grease.

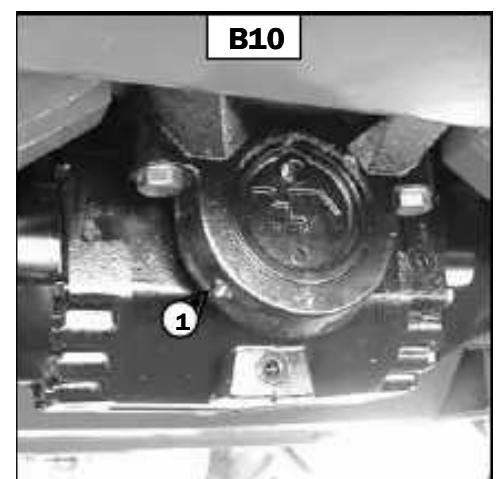

## **B11 - TRANSMISSION UNIVERSAL JOINT**

**GREASE**

Clean and lubricate the following points with grease (see : 3 - MAINTENANCE : LUBRICANTS AND FUEL) and remove the surplus grease.

- Remove access panel 1 (fig. B11/1).

<https://www.forkliftpdfmanuals.com/>

2 - Lubricators of the universal joint Transmission/Front axle (4 lubricators) (fig.

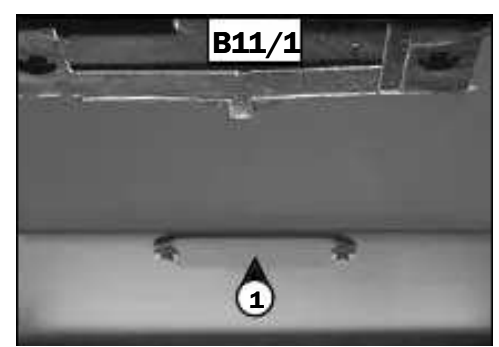

- 2 - Lubricators of the universal joint Transmission/Rear axle (2 lubricators) (fig. B11/2).
- 3 - Lubricators of the universal joint Transmission/Rear axle (3 lubricators) (fig. B11/3).

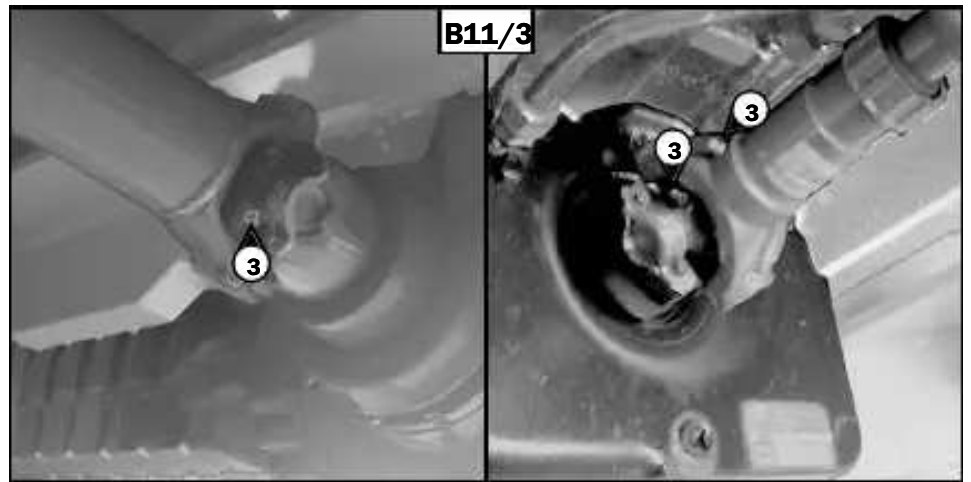
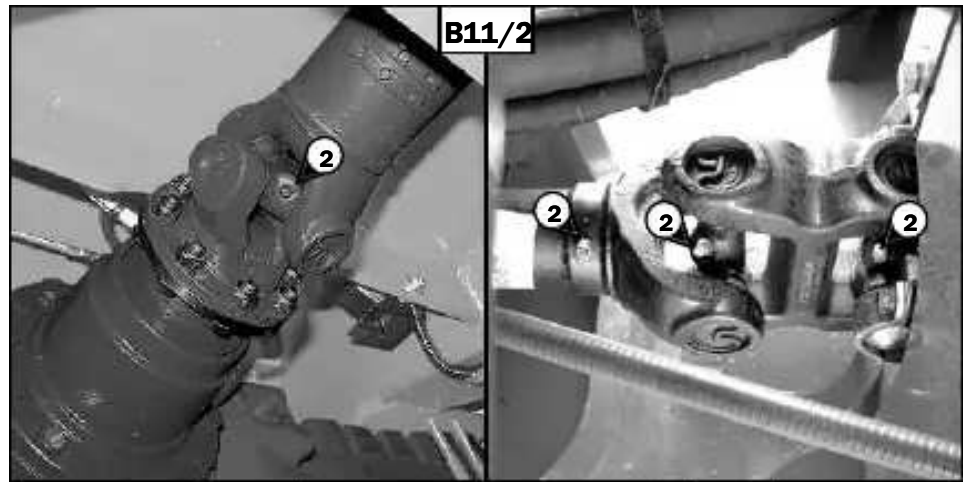
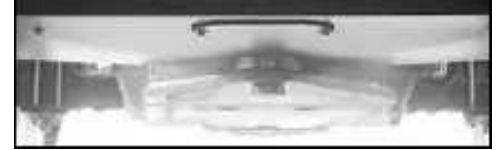

### **B12 - ARTICULATION AXLES OF THE CHASSIS**

**GREASE**

Clean and lubricate the following points with grease (see : 3 - MAINTENANCE : LUBRICANTS AND FUEL) and remove the surplus grease.

- 1 - Lubricators of the articulation axles of the chassis (3 lubricators) (fig B12).



## **CONTENTS**

### **B13 - STEERING CYLINDER**

**GREASE**

Clean and lubricate the following points with grease (see : 3 - MAINTENANCE : LUBRICANTS AND FUEL) and remove the surplus grease.

- Remove access panel 1 (fig. B13/1).
- 2 - Lubricators of the head axles of the steering cylinder (2 lubricators) (fig. B13/2).
- 3 - Lubricators of the foot axles of the steering cylinder (2 lubricators) (fig. B13/3).

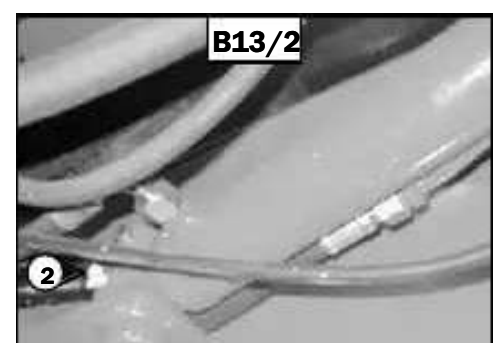
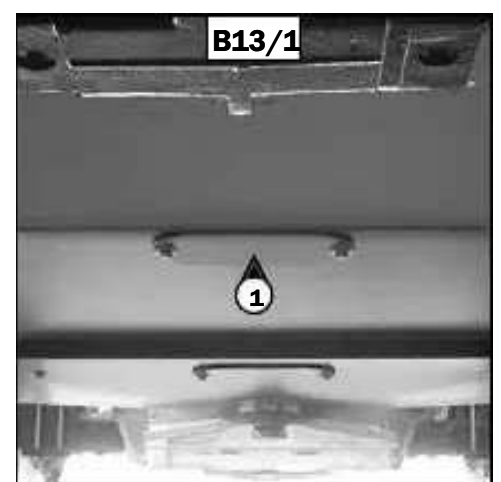

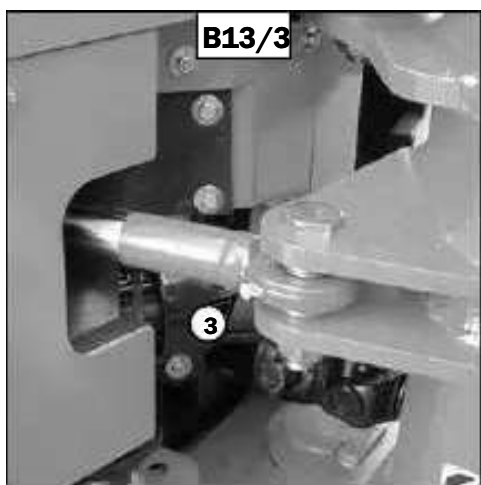
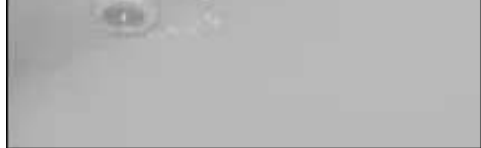

3 - 20

CONTENTS

## C - EVERY 250 HOURS SERVICE

Carry out the operations described previously as well as the following operations.

### C1 - ALTERNATOR/CRANKSHAFT BELT TENSION

#### CHECK - ADJUST

- Open the I.C. engine cover.
- Check the belt for signs of wear and cracks and change if necessary (see : 3 - MAINTENANCE : FILTERS CARTRIDGES AND BELTS).
- Check the belt tension between the pulleys of the crankshaft and of the alternator.
- Under a normal pressure exerted with the thumb (10 ft/lb), the tension should be approximately 3/8 in.
- Carry out adjustments if necessary.
- Loosen screws 1 (fig. C1) by two to three thread turns.
- Swivel the alternator assembly so as to obtain the belt tension required.
- Retighten screws 1 (fig. C1)(tightening torque 16 ft/lb).

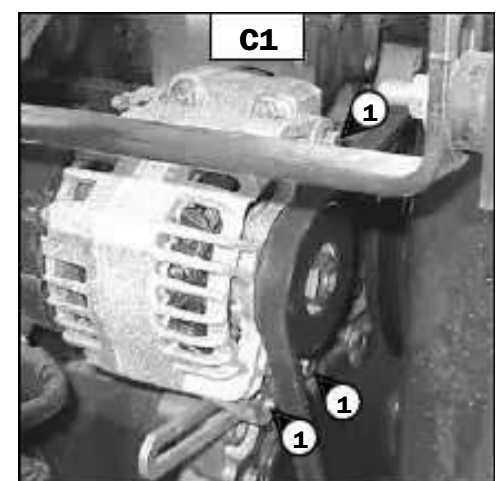

#### IMPORTANT

If the alternator belt has to be changed, check the tension again after the first 20 hours of operation.

## C2 - COMPRESSOR BELT TENSION (OPTION AIR CONDITIONING)

### CHECK - ADJUST

- Open the I.C. engine cover.
- Check the belt for signs of wear and cracks and change if necessary (see : 3 - MAINTENANCE : FILTERS CARTRIDGES AND BELTS).
- Check the belt tension between the pulleys of the crankshaft and of the compressor.
- Under a normal pressure exerted with the thumb (10 ft/lb), the tension should be approximately 3/8 in.
- Carry out adjustments if necessary.
- Loosen screws 1 (fig. C2) by two to three thread turns.
- Swivel the compressor assembly so as to obtain the belt tension required.
- Retighten screws 1 (fig. C2).

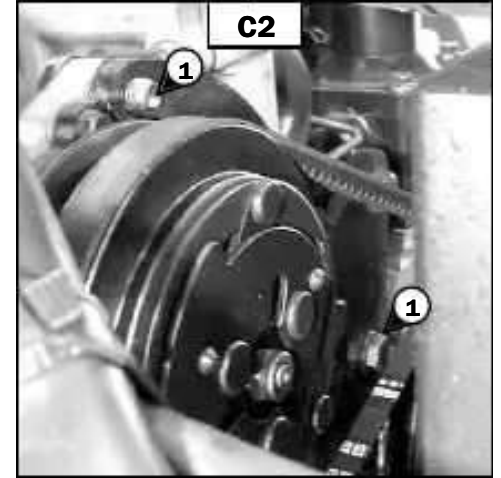

### IMPORTANT

If the alternator belt has to be changed, check the tension again after the first 20 hours of operation.

## C3 - PARKING BRAKE

### CHECK - ADJUST

Park the lift truck on a slope less than 15 % with the rated load in the transport position.

- Check the tightening adjustment by locking the parking brake in position A (fig. C3/1).
- The adjustment is correct when the lift truck is held stationary on a slope.
- Carry out adjustments if necessary.

### ADJUSTMENT OF THE PARKING BRAKE CABLE ON THE FRONT AXLE

- Press and release the brake pedal, then release the parking brake, putting it in position B (fig. C3/1).
- Remove the cover plate 1 (fig. C3/2).
- Unscrew nuts 2 (fig. C3/3).
- Adjust the cable by loosening nuts 2 (fig. C3/3), until a clearance of 0.06 in. between cams 3 (fig. C3/3) and stops 4 (fig. C3/3) is obtained.

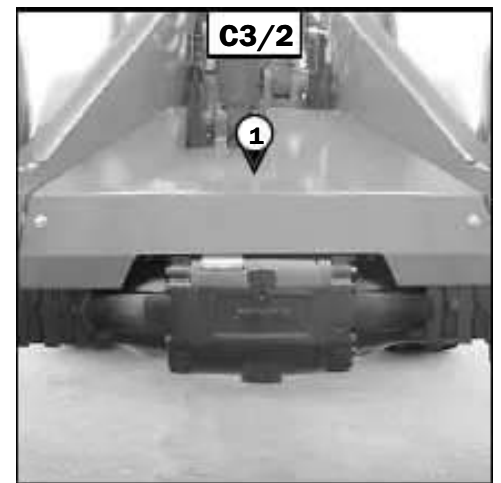
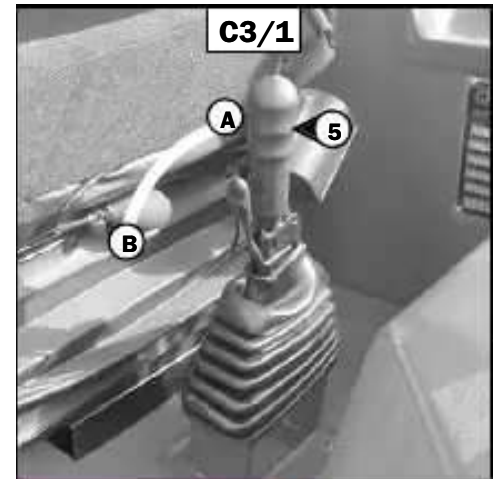

### WARNING

Make adjustments only to the stops noted. DO NOT MAKE ADJUSTMENTS TO THE DRIVE AXLE FACTORY SETTINGS! (CONTACT YOUR DEALER.)

### ADJUSTMENT OF THE PARKING BRAKE

- Leave the parking brake in position B (fig. C3/1).
- Progressively tighten the end piece of the lever 5 (fig. C3/1) and recheck braking.
- Repeat the operation until the correct braking adjustment is obtained.

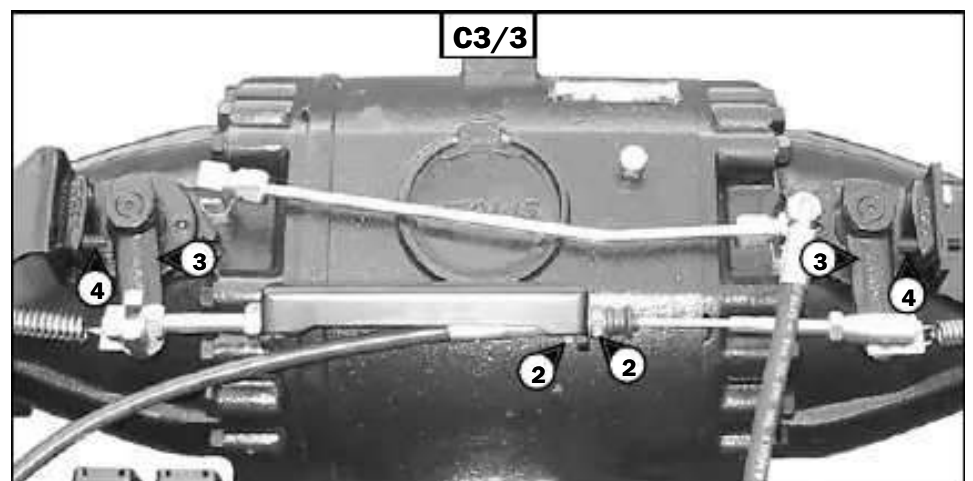

## C4 - CAB VENTILATION FILTER (OPTION AIR CONDITIONING)

### CHANGE

- Lift up protective casing 1 (fig. C4).
- Lift out cabin ventilation filter 2 (fig. C4) and fit new replacement filter (see : 3 - MAINTENANCE : FILTERS CARTRIDGES AND BELTS).
- Install the protective casing.

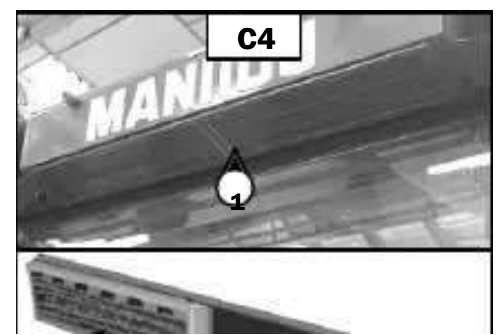

## **C5 - FRONT AND REAR AXLE DIFFERENTIAL OIL LEVEL**

**CHECK**

Park the lift truck on level ground with the I.C. engine stopped.

- Remove level plug 1 (fig. C5). The oil should be flush with the edge of the hole.
- If necessary, add oil (see : 3 - MAINTENANCE : LUBRICANTS AND FUEL) by the filler port 2 (fig. C5).
- Replace and tighten the level plug 1 (fig. C5) (tightening torque 32 ft/lb).
- Repeat this operation for the rear axle differential.



## **C6 - FRONT AND REAR WHEELS REDUCERS OIL LEVEL**

**CHECK**

Park the lift truck on level ground with the I.C. engine stopped.

- Check the level on each front wheel reducer.
- Place level plug 1 (fig. C6) in the horizontal position.
- Remove the level plug ; the oil should be flush with the edge of the hole.
- If necessary, add oil (see : 3 - MAINTENANCE : LUBRICANTS AND FUEL) by the same hole.
- Replace and tighten the level plug 1 (fig. C6) (tightening torque 32 ft/lb).
- Repeat the same operation on each rear wheel reducer.

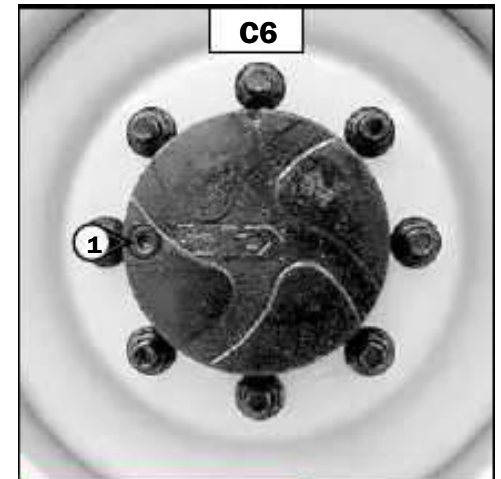

## **D - EVERY 500 HOURS SERVICE**

*Carry out the operations described previously as well as the following operations.*

### **D1 - I.C. ENGINE OIL**

**DRAIN**

### **D2 - I.C. ENGINE OIL FILTER**

**CHANGE**

Park the lift truck on level ground, let the I.C. engine run at idle for a few minutes, then stop the I.C. engine.

#### **DRAINING THE OIL**

- Open the I.C. engine cover.
- Remove access panel 1 (fig. D1/1).
- Place a container under drain plugs 2 (fig. D1/2) and under the oil filter 3 (fig. D1/2).
- Unscrew the drain plugs 3 (fig. D1/2).
- Remove filler cap 4 (fig. D1/3) in order to ensure that the oil is drained properly.

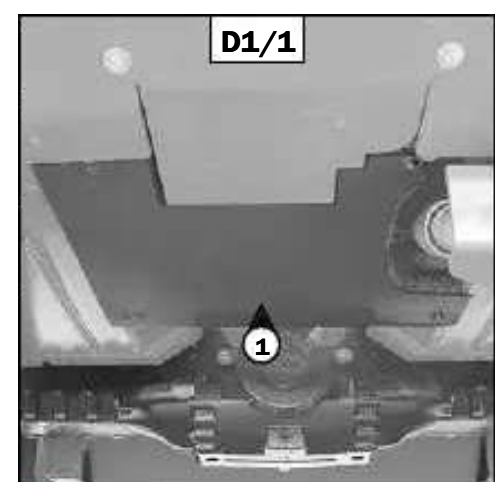

**IMPORTANT**

Dispose of the drain oil in an ecological manner. <https://www.forkliftpdfmanuals.com/>

### REPLACEMENT OF THE FILTER

- Remove I.C. engine oil filter 3 (fig. D1/2) ; discard the filter and the filter seal.
- Clean the filter bracket with a clean, lint-free cloth.
- Lightly grease the new oil filter seal and install the oil filter (see : 3 - MAINTENANCE : FILTERS CARTRIDGES AND BELTS) on the filter bracket.

#### IMPORTANT

*Tighten the oil filter by hand pressure only and lock the filter in place by a quarter turn.*

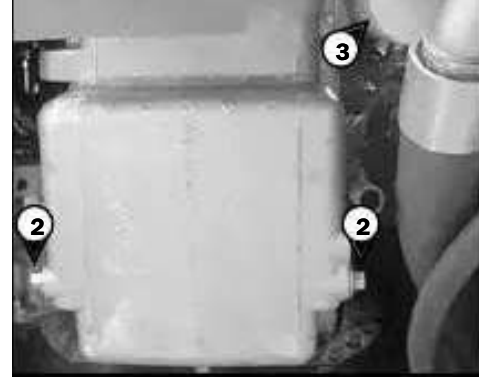

### FILLING UP THE OIL

- Install and tighten drain plugs 2 (fig. D1/2).
- Install access panel 1 (fig. D1/1).
- Fill up with oil (see : 3 - MAINTENANCE : LUBRICANTS AND FUEL) by filler port 5 (fig. D1/3).
- Wait a few minutes to allow the oil to flow into the sump.
- Start the I.C. engine and let it run for a few minutes.
- Check for possible leaks at the drain plug and the oil filter.
- Stop the I.C. engine, wait a few minutes and check the level between the two notches on dipstick 6 (fig. D1/3).
- Top up the level if necessary.

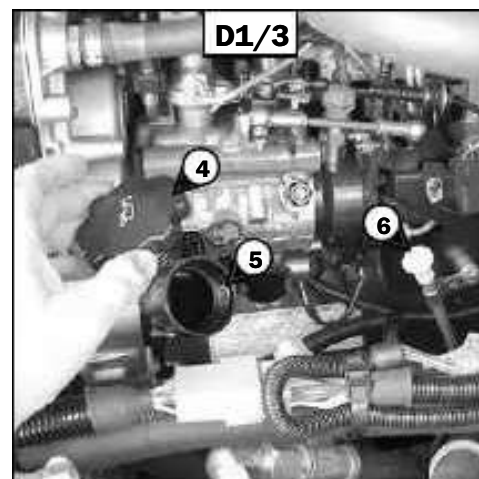

## CONTENTS

### D3 - DRY AIR FILTER CARTRIDGE

#### CHANGE

In case of use in a heavily dust laden atmosphere, there are pre-filtration cartridges, see : 3 - MAINTENANCE : FILTERS CARTRIDGES AND BELTS. Also, the checking and cleaning schedule of the cartridge must be reduced (up to 250 hours in a heavily laden dust atmosphere and with pre-filtration).

#### IMPORTANT

*Change the cartridge in a clean location, with the I.C. engine stopped. Never run the I.C. engine with the air filter removed or damaged.*

- Open the I.C. engine cover.
- Loosen the bolts and remove cover 1 (fig. D3).
- Gently remove the cartridge 2 (fig. D3), taking care to avoid spilling the dust.
- Leave the safety cartridge in place.
- The following parts must be cleaned with a damp, clean lint-free cloth.
  - The inside of the filter and cover.
  - The inside of the filter inlet hose.
  - The gasket surfaces in the filter and in the cover.
- Check pipes and connections between the air filter and the I.C. engine and the connection and state of the clogging indicator on the filter.
- Before installing check the state of the new cartridge (see : 3 - MAINTENANCE : FILTERS CARTRIDGES AND BELTS).
- Introduce the cartridge into the filter axis and push it in, pressing the edges and not the middle.
- Reassemble the cover, guiding the valve downwards.

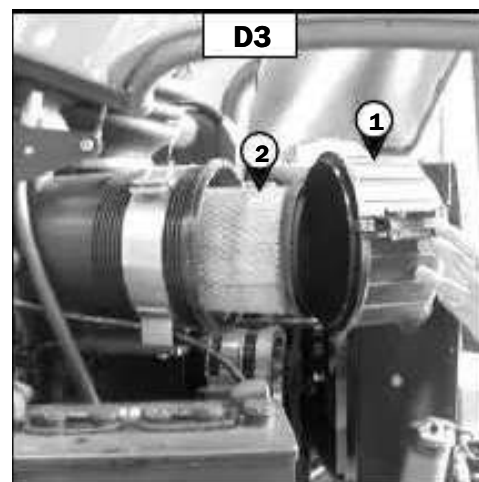



## D4 - FUEL FILTER CARTRIDGE

CHANGE

### IMPORTANT

Make sure the electrical contact on the lift truck is off, otherwise fuel will be released if the lift pump is on.

- Open the I.C. engine cover.
- Carefully clean the outside of the filter and its holder, to prevent dust from getting into the system.
- Place a container under the filter and drain it via drain plug 1 (fig. D4/1).
- Loosen the body of filter 2 (fig. D4/1).
- Remove the filter cartridge by pressing the cartridge 3 (fig. D4/2) down against the pressure of the spring and turn it to the left to extract it.
- Insert a new cartridge (see : 3 - MAINTENANCE : FILTERS CARTRIDGES AND BELTS), by pressing the cartridge 3 (fig. D4/2) down against the pressure of the spring and turn it to the right to lock it into the body of the filter.
- Place the new seal 4 (fig. D4/2) onto the body of the filter and lubricate the contact surface using clean engine oil.
- Install the body of the filter onto its holder, hand-tighten it only and lock it with a quarter-turn.
- Close drain plug 1 (fig. D4/1) and remove the container.
- Before starting the I.C. engine, leave the ignition on for one minute on the lift truck, to give the lift pump time to pump air from the filter.
- Start up the I.C. engine and make sure there is no leakage.

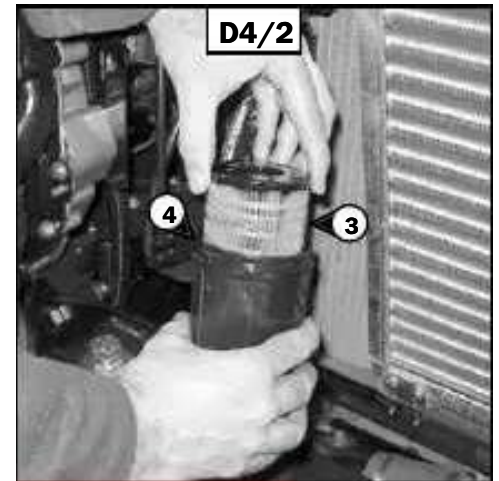
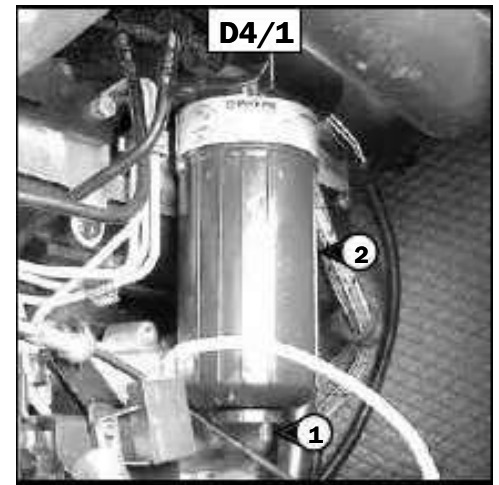

## D5 - TRANSMISSION OIL FILTER

CHANGE

- Remove the cover plate 1 (fig. D5).
- Unscrew and discard the transmission oil filter 2 (fig. D5).
- Carefully clean the filter head with a clean, lint-free cloth.
- Slightly lubricate the new seal and fit the seal on the filter.
- Install the new transmission oil filter (see : 3 - MAINTENANCE : FILTERS CARTRIDGES AND BELTS), making sure that the seal is correctly positioned and tightened.

### IMPORTANT

Tighten the transmission oil filter by hand pressure only and lock the filter in place by a quarter turn.

- Install the cover plate 1 (fig. D5).

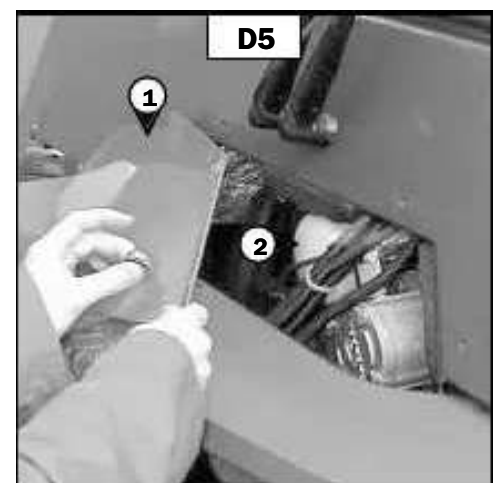

3 - 25

## CONTENTS

## D6 - HYDRAULIC RETURN OIL FILTER CARTRIDGE

CHANGE

Stop the I.C. engine and remove the pressure from the circuits by acting on the hydraulic controls.

### IMPORTANT

Thoroughly clean the outside of the filter and its surroundings before any intervention, to prevent risk of polluting the hydraulic circuit.

- Open the I.C. engine cover.
- Unscrew the locking screws of the cover 1 (fig. D6).
- Remove the hydraulic return oil filter cartridge 2 (fig. D6), and fit new replacement cartridge (See chapter : FILTERS CARTRIDGES AND BELTS in paragraph : 3 - MAINTENANCE).
- Make sure that the cartridge is correctly positioned and install cover 1 (fig. D6).

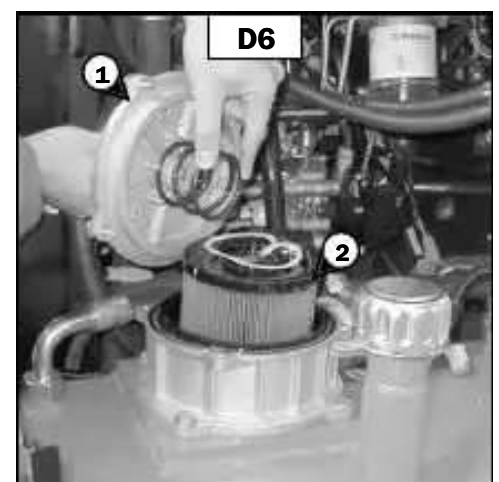

## D7 - BALANCING VALVE

CHECK

To be performed after the first 50 hours of operation and then every 500 hours.  
Park the lift truck on horizontal ground, put the handbrake on and set the reverse gear to neutral.

### ROLE OF BALANCING VALVES

<https://www.forkliftpdfmanuals.com/>

- The balancing valves protect the user from any risk due to a fall in hydraulic pressure or an exploding hose during hydraulic operation.

The balancing valves protect the user from any risk due to a fall in hydraulic pressure or an exploding hose during hydraulic operations.



## DANGER

Keep everyone well away during these inspections. In all cases, the balancing valve(s) concerned must be repaired or replaced if hydraulic movement continues after the I.C. engine has been switched off. Never use the lift truck with a defective balancing valve.

### TESTING EACH HYDRAULIC MOVEMENT

#### LIFTING CIRCUIT :

- Start up the lift truck and raise the boom by about 45°.
- With the I.C. engine running at mid- speed, lower the boom. While the boom is being lowered, switch off the I.C. engine; movement should slow down as the I.C. engine speed falls and stop when the I.C. engine stops.

#### TELESCOPING CIRCUIT :

- Start up the lift truck and raise the boom as far as it will go, extending the telescope(s) completely.
- With the I.C. engine running at mid- speed, retract the telescope(s). When retracting the boom, switch off the I.C. engine; movement should slow down as the I.C. engine speed falls and stop when the I.C. engine stops.

#### TILT CIRCUIT :

- Place the nominal load on the forks, anchor it correctly to prevent it from falling off during the test.
- Start up the lift truck and tilt the carriage backwards, lifting the boom sufficiently to allow the carriage to tilt.
- With the I.C. engine running at mid-speed, tilt the carriage forwards. While it is tilting, switch off the I.C. engine; movement should slow down as the I.C. engine speed falls and stop when the I.C. engine stops.

### **D8 - PARKING BRAKE LEVER MECHANISM**

#### GREASE

- Clean and grease articulation axles 1 (fig. D8) with grease (see : 3 - MAINTENANCE : LUBRICANTS AND FUEL).

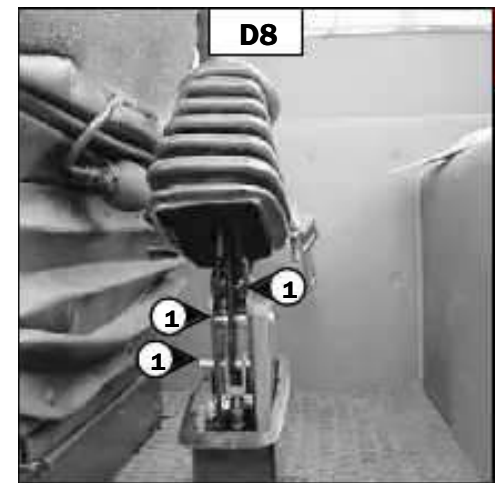

3 - 26

## CONTENTS

### **D9 - BRAKING PRESSURE OIL FILTER CARTRIDGE**

#### CHANGE

Stop the I.C. engine and remove the pressure from the circuits by acting on the hydraulic controls.

#### IMPORTANT

Thoroughly clean the outside of the filter and its surroundings before any intervention, to prevent risk of polluting the hydraulic circuit.

- Remove the shroud 1 (fig. D9/1).
- Place a container under the braking pressure oil filter.
- Unscrew the body of the filter 2 (fig. D9/2).
- Remove the braking pressure oil filter cartridge, and fit new replacement cartridge (see : 3 - MAINTENANCE : FILTERS CARTRIDGES AND BELTS).
- Make sure that the cartridge and gaskets are correctly positioned and install the body of the filter 2 (fig. D9/2).

#### IMPORTANT

Tighten the body of the filter by hand pressure only and lock the body of the filter in place by a quarter turn.

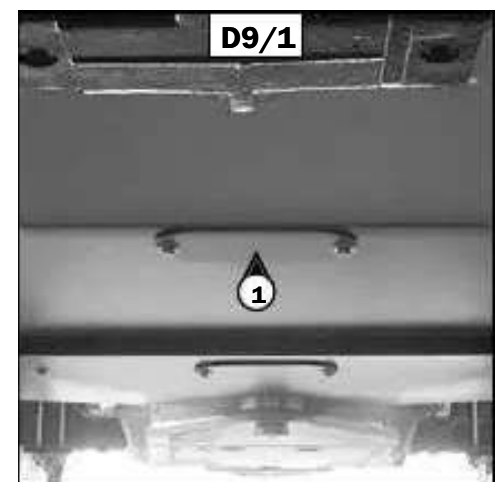



## D10 - CAB VENTILATION FILTER

**CLEAN**

- Lift up protective casing 1 (fig. D10).
- Lift out cabin ventilation filters 2 (fig. D10).
- Clean the filter with a compressed air jet.
- Check its condition and change if necessary (see : 3 - MAINTENANCE : FILTERS CARTRIDGES AND BELTS).
- Install the filters and protective casing.

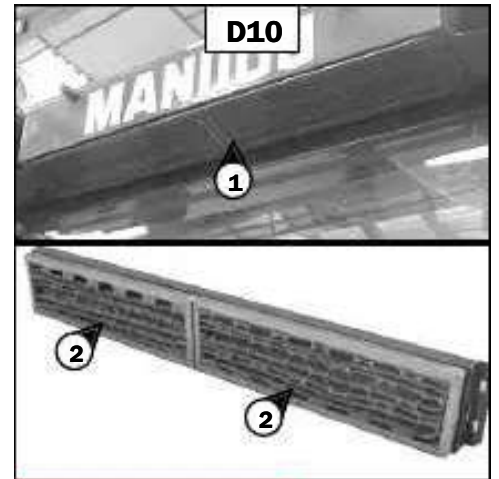

## D11 - BATTERY ELECTROLYTE DENSITY

**CHECK**

The electrolyte density varies depending on the temperature concerned, but a minimum of 1.260 at 61°F must be maintained. In the shaded area (fig. D11), the battery is in a normal charge condition. Readings above this zone indicate that the battery needs to be recharged.

The density should not vary more than 0.025 units between cells.

- Check the electrolyte density in each battery cell using a hydrometer.
- Do not carry out this check immediately after topping up with distilled water. Recharge the battery for at least an hour before checking the battery electrolyte density.

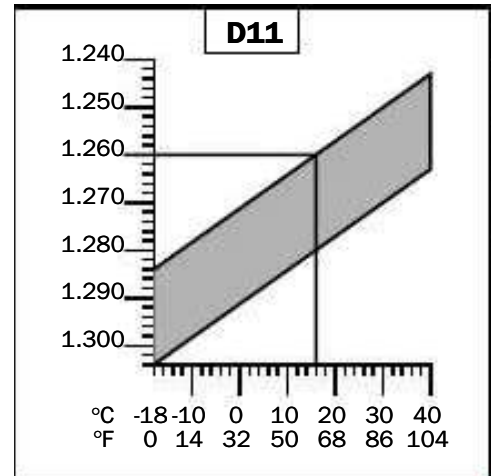

 <b>WARNING</b>	<p>Handling and servicing a battery can be dangerous, take the following precautions :</p> <ul style="list-style-type: none"> <li>- Wear protective goggles.</li> <li>- Keep the battery horizontal.</li> <li>- Never smoke or work near an open flame.</li> <li>- Work in a well-ventilated area.</li> <li>- In the event of electrolyte being spilled onto the skin or splashed in the eyes, rinse thoroughly with cold water for 15 minutes and call a doctor.</li> </ul>
--------------------	--

3 - 27

## CONTENTS

## D12 - FRONT AND REAR AXLE DIFFERENTIAL OIL

**DRAIN**

Park the lift truck on level ground with the I.C. engine stopped and the differential oil still warm.

<b>IMPORTANT</b>	Dispose of the drain oil in an ecological manner.
------------------	---

- Place a container under drain plugs 1 (fig. D12/1) and unscrew the plugs.
- Remove level plug 2 (fig. D12/1) and filler plug 3 (fig. D12/1) in order to ensure that the oil is drained properly.
- Install and tighten drain plugs 1 (fig. D12/1) (tightening torque 32 ft/lb).
- Fill up with oil (see : 3 - MAINTENANCE : LUBRICANTS AND FUEL) by filler port 3 (fig. D12/1).
- The level is correct when the oil level is flush with the edge of port 2 (fig. D12/1).
- Check for any possible leaks at the drain plugs.
- Install and tighten level plug 2 (fig. D12/1) (tightening torque 32 ft/lb) and filler plug 3 (fig. D12/1) (tightening torque 32 ft/lb).
- Repeat this operation for the rear axle differential (fig. D12/2).

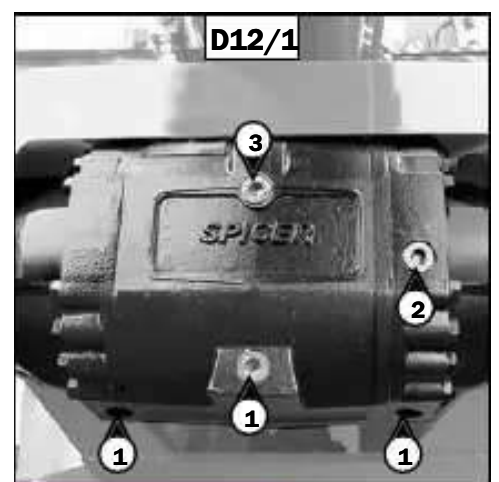

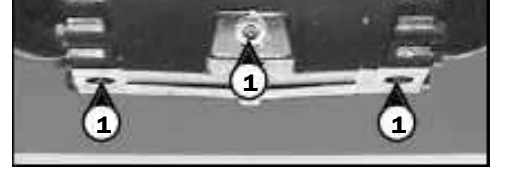

3 - 28

CONTENTS

## E - EVERY 1000 HOURS SERVICE

Carry out the operations described previously as well as the following operations.

### E1 - FUEL TANK

**CLEAN**



#### WARNING

While carrying out these operations, do not smoke or work near a flame.

Park the lift truck on level ground with the I.C. engine stopped.

- Inspect the parts susceptible to leaks in the fuel circuit and in the tank.
- In the event of a leak, contact your dealer.



#### WARNING

Never perform welding on the fuel system, this could cause an explosion or a fire.

- Place a container under drain plug 1 (fig. E1/1) and unscrew the plug.
- Remove cap 2 (fig. E1/2).
- Let the fuel flow and flush with 2 gal. of clean fuel by filler port 3 (fig. E1/2).
- Install and tighten drain plug 1 (fig. E1/1).
- Fill the fuel tank with clean fuel (see : 3 - MAINTENANCE : LUBRICANTS AND FUEL) fil-

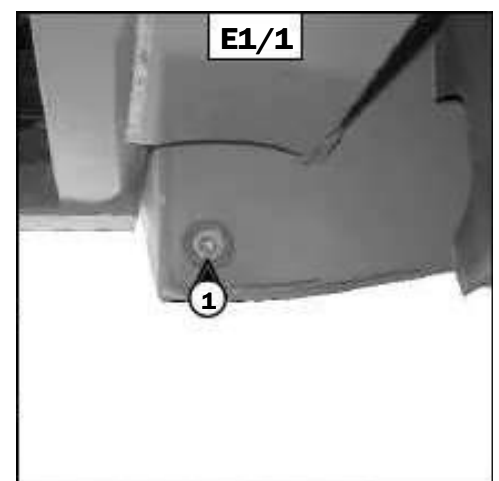

- tered through a strainer or a clean, lint-free cloth and install the filler plug 2 (fig. E1/2).
- If necessary, bleed the fuel circuit (see : 3 - MAINTENANCE : G1 - FUEL SYSTEM).



## **E2 - SAFETY DRY AIR FILTER CARTRIDGE**

### **CHANGE**

- For the disassembly and reassembly of the cartridge, see : 3 - MAINTENANCE : D3 - DRY AIR FILTER CARTRIDGE.
- Gently remove the dry air filter safety cartridge 1 (fig. E2), taking care to avoid spilling the dust.
- Clean the gasket surface on the filter with a damp, clean lint-free cloth.
- Before installing check the state of the new safety cartridge (see : 3 - MAINTENANCE : FILTERS CARTRIDGES AND BELTS).
- Introduce the cartridge into the filter axis and push it in, pressing the edges and not the middle.

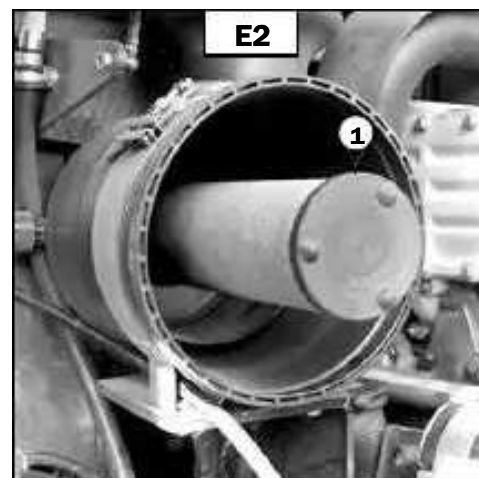

NOTE : The schedule for changing the safety cartridge is given for reference only. The safety cartridge must be changed for every two changes of the air filter cartridge.

## **E3 - TRANSMISSION OIL**

### **DRAIN**

Park the lift truck on level ground with the I.C. engine stopped, the transmission oil still warm.

#### **DRAINING THE OIL**

- Remove access panel 1 (fig. E3/1).
- Place a container under drain plug 2 (fig. E3/2) and unscrew the drain plug.
- Remove access panel 3 (fig. E3/3).
- Remove dipstick 4 (fig. E3/4) in order to ensure that the oil is drained properly.

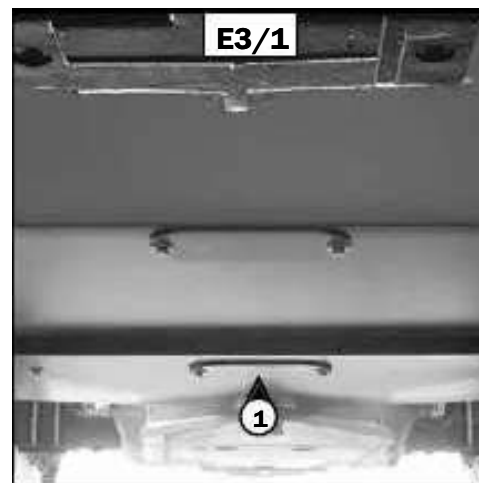

#### **IMPORTANT**

*Dispose of the drain oil in an ecological manner.*

## **CONTENTS**

#### **FILLING UP THE OIL**

- Install and tighten drain plug 1 (fig. E3/1) (tightening torque 32 ft/lb).
- Fill up with oil (see : 3 - MAINTENANCE : LUBRICANTS AND FUEL) by filler port 4 (fig. E3/4) and install the plug.
- Check oil nivel (see : 3 - MAINTENANCE : A5 - CHECK THE TRANSMISSION OIL LEVEL).

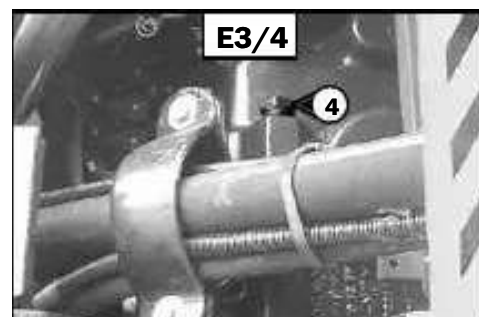
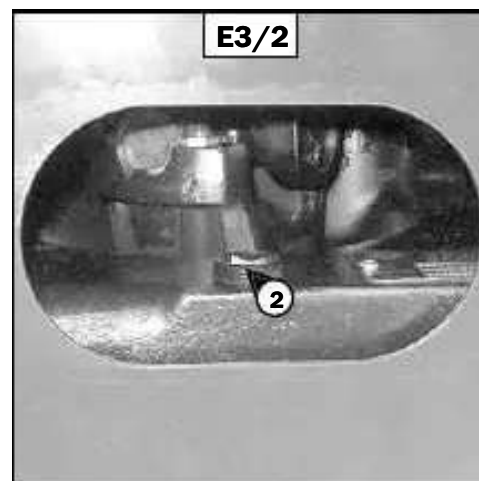



## E4 - HYDRAULIC OIL

**DRAIN**

## E5 - SUCTION STRAINER FOR HYDRAULIC OIL TANK

**CLEAN**

## E6 - FILTER CAP FOR HYDRAULIC OIL TANK

**CHANGE**

Park the lift truck on level ground with the I.C. engine stopped and telescope boom retracted and lowered as far as possible.

### IMPORTANT

*Before any intervention, thoroughly clean the area surrounding the drain plugs and the suction cover on the hydraulic tank.*

### DRAINING THE OIL

- Place a container under drain plugs 1 (fig. E4/1) and unscrew the plug.
- Remove filler cap 2 (fig. E4/2) in order to ensure that the oil is drained properly.

### IMPORTANT

*Dispose of the drain oil in an ecological manner.*

### CLEANING THE STRAINER

- Remove suction cover 3 (fig. E4/3).
- Remove and clean the strainer using a compressed air jet, check its condition and replace if necessary (see : 3 - MAINTENANCE : FILTERS CARTRIDGES AND BELTS).
- Install the strainer and tighten the suction cover 3 (fig. E4/3) (Tightening torque 60 ft/lb) making sure the seal is in the correct position.

### FILLING UP THE OIL

- Clean and install drain plug 1 (fig. E4/1) (tightening torque 26 ft/lb).
- Fill up with oil (see : 3 - MAINTENANCE : LUBRICANTS AND FUEL) by filler port 4 (fig. E4/2).

### IMPORTANT

*Use a clean container and funnel, and clean the underside of the oil nozzle before filling.*

- Observe the oil level on dipstick 5 (fig. E4/4) ; the oil level should be at the level of the red point.
- Check for any possible leaks at the drain plug.
- Replace filler plug 2 (fig. E4/2) with a new filler plug (see : 3 - MAINTENANCE : FILTERS CARTRIDGES AND BELTS).

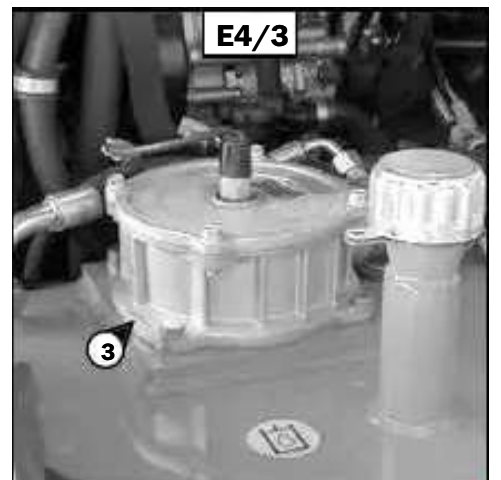
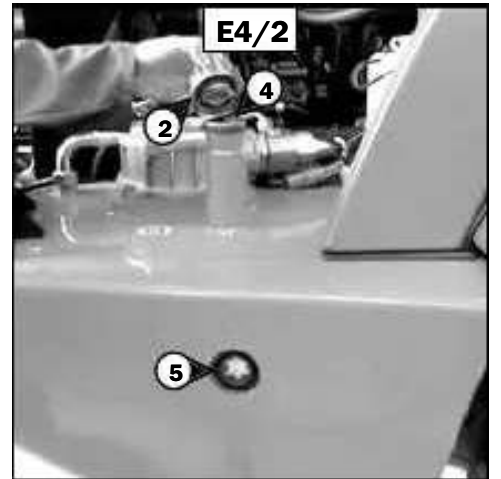
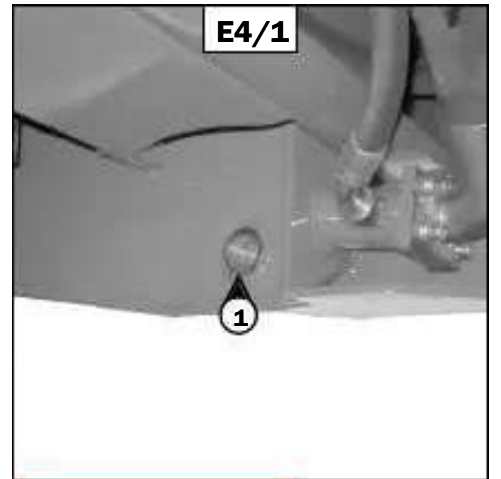

## POLLUTION ABATEMENT OF THE HYDRAULIC CIRCUIT

### MLA 628 -120 LSU POWERSHIFT Series 3-E2

This should be carried out by your dealer after each oil change.

The hydraulic oil used in the circuit must be at least equal in quality to class 8 (according to NAS 1638). Your dealer will be able to clean the hydraulic circuit using an external unit and check the quality of the oil in order to ensure the long life of hydraulic components and particularly of the main pump.

## E7 - SEAT BELT

**CHECK**

### SEAT BELT WITH TWO ANCHORING POINTS

- Check the following points :
  - Fixing of the anchoring points on the seat.
  - Cleanness of the strap and the locking mechanism.
  - Triggering of the locking mechanism.
  - Condition of the strap (cuts, curled edges).

### REELED SEAT BELT WITH TWO ANCHORING POINTS

- Check the points listed above together with the following points :
  - The correct winding of the belt.
  - Condition of the reel guards.

- Condition of the reel guards.
- Roller locking mechanism when the strap is given a sharp tug.

NOTE : After an accident, replace the seat belt.



## WARNING

*Under no circumstances should you use the lift truck if the seat belt is damaged! Repair or replace the seat belt immediately!*

## ***E8 - FRONT AND REAR WHEELS REDUCERS OIL***

### ***DRAIN***

Park the lift truck on level ground with the I.C. engine stopped and the reducers oil still warm.

## IMPORTANT

*Dispose of the drain oil in an ecological manner.*

- Drain and change each front wheel reducer.
- Place drain plug 1 (fig. E8) in position A.
- Place a container under the drain plug and unscrew the plug.
- Let the oil drain fully.
- Place the drain port in position B, i.e. in a level port.
- Fill up with oil (see : 3 - MAINTENANCE : LUBRICANTS AND FUEL) by level port 1 (fig. E10).
- The level is correct when the oil level is flush with the edge of the hole.
- Install and tighten the drain plug 1 (fig. E8) (tightening torque 32 ft/lb).
- Repeat this operation on each rear wheel reducer.

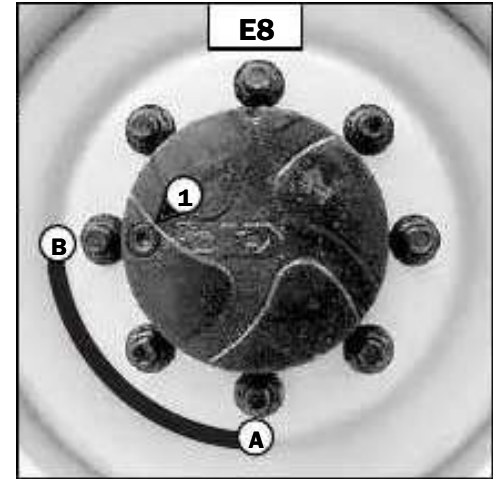



## F - EVERY 2000 HOURS SERVICE

Carry out the operations described previously as well as the following operations.

### F1 - COOLING LIQUID

These operations are to be carried out if necessary or every two years at the beginning of winter. Park the lift truck on level ground with the I.C. engine stopped and cold.

#### **DRAINING THE LIQUID**

- Open the I.C. engine cover.
- Place a container under drain plug 1 (fig. F1/1) of the radiator and drain plug 2 (fig. F1/2) of the I.C. engine block and unscrew the plugs.
- Remove filler cap 3 (fig. F1/3) of the expansion pan 4 (fig. F1/3).
- Let the cooling circuit drain entirely while ensuring that the ports do not get clogged.
- Check the condition of the hoses as well as the fastening devices and change the hoses if necessary.
- Rinse the circuit with clean water and use a cleaning agent if necessary.

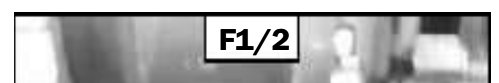
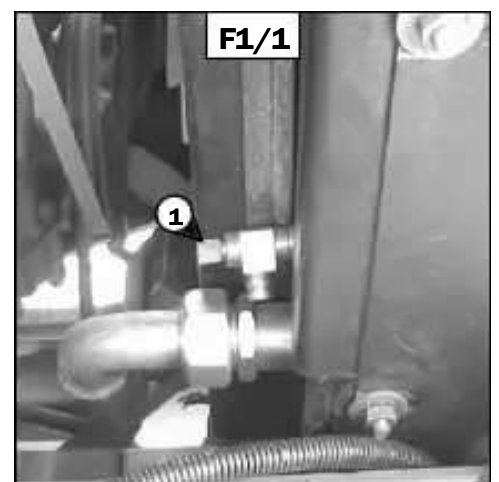

#### FILLING THE LIQUID

- Tighten the drain valve 2 (fig. F1/2) and drain plug 3 (fig. F1/3) (tightening torque 30 ft/lb).
- Slowly fill up the cooling circuit (see : 3 - MAINTENANCE : LUBRICANTS AND FUEL) to half way up the expansion pan 5 (fig. F1/4).
- Install filler cap 4 (fig. F1/4).
- Run the I.C. engine at idle for a few minutes.
- Check for any possible leaks.
- Check the level and refill if necessary.

#### IMPORTANT

*To prevent corrosion the I.C. engine cooling system must be filled with a minimum mixture of 25 % ethylene glycol-based antifreeze.*

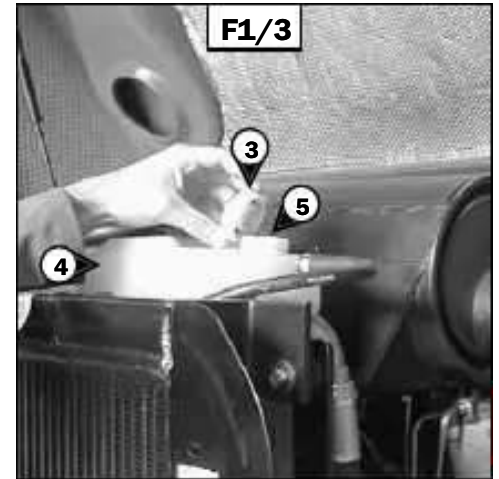
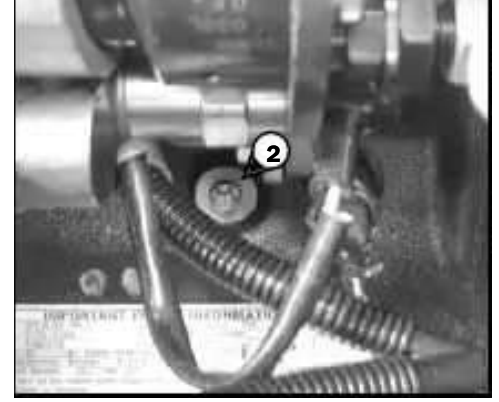

## G - OCCASIONAL MAINTENANCE

### G1 - FUEL SYSTEM

#### BLEED

These operations are to be carried out only in the following cases :

- A component of the fuel system replaced.
- A drained tank.
- Running out of fuel.

Ensure that the level of fuel in the tank is sufficient and bleed in the following order :

- Open the I.C. engine cover.
- Remove the muffler 1 (fig. G1/1).
- Put the ignition on for three minutes on the lift truck, to give the lift pump time to pump air from the filter.
- Switch off the ignition with the ignition key.

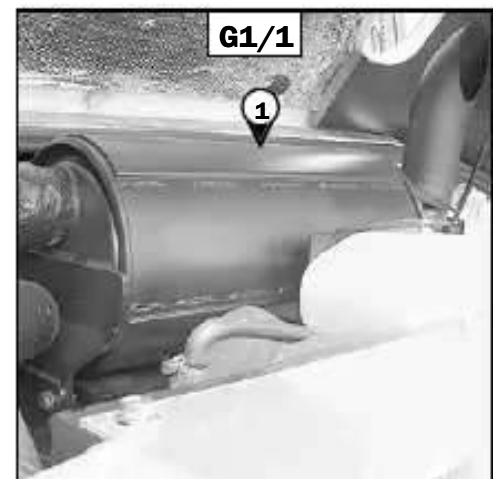

#### BLEEDING THE INJECTORS

- Remove the injectors cover 2 (fig. G1/2).

<https://www.forkliftpdfmanuals.com/>



- Loosen high pressure connectors 3 (fig. G1/3) of all the injectors.
- Activate the starter until the diesel fuel flows out free of air at high pressure connectors 3 (fig. G1/3).

### IMPORTANT

*Do not engage the starter motor on a continual basis for more than 30 seconds and let it cool between unsuccessful attempts.*

- Tighten the connection while the diesel fuel is flowing out (tightening torque 22 ft/lb).
- Install the muffler 1 (fig. G1/1).
- The I.C. engine is then ready to be started up.
- Turn the I.C. engine over slowly for 5 minutes immediately after bleeding the fuel feed circuit, in order to ensure that the injection pump has been bled thoroughly.

NOTE : If the I.C. engine functions correctly for a short time then stops or functions irregularly, check for possible leaks in the low pressure circuit. If in doubt, contact your dealer.

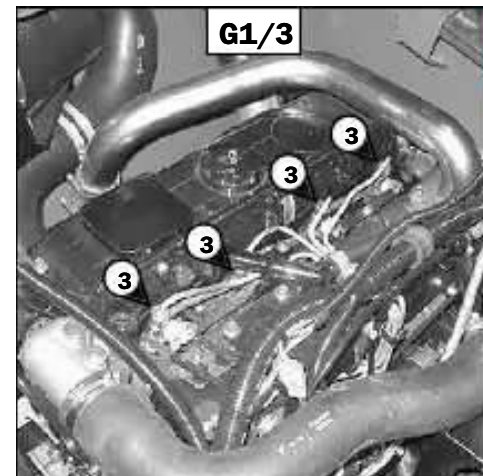

## CONTENTS

### G2 - WHEEL

CHANGE



### WARNING

*In the event of a wheel being changed on the public highway, make sure of the following points*

For this operation we advise you to use an approved hydraulic jack and safety support (contact your dealer).

- Park the lift truck, if possible on even and hard ground.
- Put the warning lights on.
- Immobilize the lift truck in both directions on the axle opposite to the wheel to be changed.
- Unlock the nuts of the wheel to be changed.
- Place the jack under the flared axle tube, as near as possible to the wheel and adjust the jack (fig. G2/1).
- Lift the wheel until it comes off the ground and put in place the safety support under the axle (fig. G2/2).
- Completely unscrew the wheel nuts and remove them.
- Free the wheel by reciprocating movements and roll it to the side.
- Slip the new wheel on the wheel hub. <https://www.forkliftpdfmanuals.com/>
- Install the nuts by hand, if necessary grease them.



- Remove the safety support and lower the lift truck with the jack.
- Tighten the wheel nuts with a torque wrench (see : 3 - MAINTENANCE : A - DAILY OR EVERY 10 HOURS SERVICE for tightening torque).



### G3 - LIFT TRUCK

**TOW**

<b>IMPORTANT</b>	<i>Do not tow the lift truck at more than 15 mph.</i>
------------------	---

- Put the forward/reverse lever and the gear shift in neutral (as model of lift truck).
- Release the parking brake.
- Put the warning lights on.
- If the I.C. engine is not running there will be no steering or braking assistance. Operate the steering and pedal slowly avoiding sudden abrupt movements.

### G4 - LIFT TRUCK

**SLING**

- Take into account the position of the lift truck gravity center for lifting (fig. G4/1).
- A = 58.3 in.      B = 40.2 in.**
- Place the hooks in the fastening points provided (fig. G4/2 and G4/3).

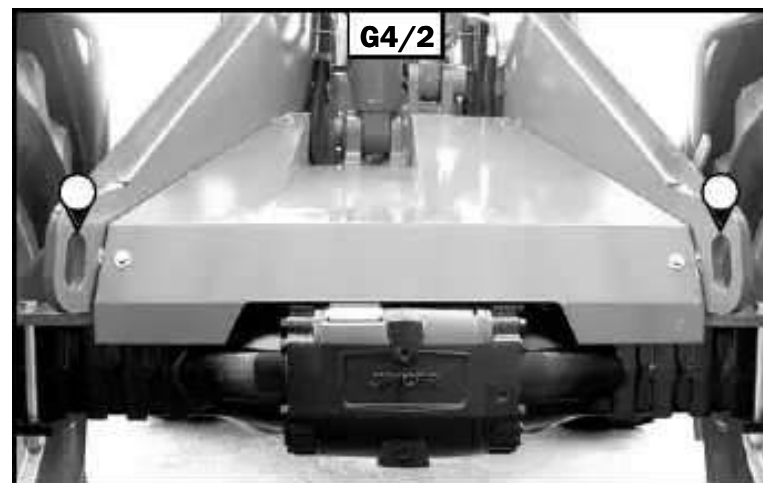
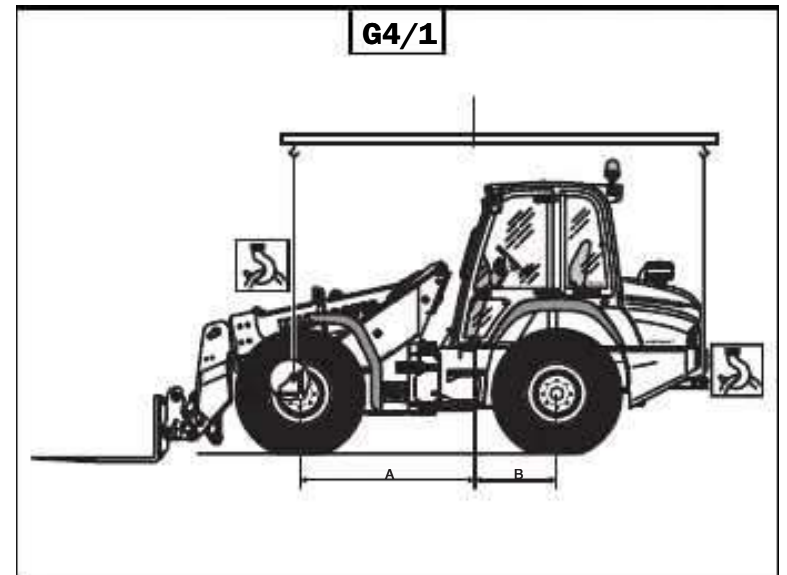

**3 - 37**

## CONTENTS

### G5 - LIFT TRUCK ON A PLATFORM

**TRANSPORT**

<b>WARNING</b>	<i>Ensure that the safety instructions for the platform are followed before loading the lift truck and that the driver of transport is informed about the dimensions and weight of the lift truck.</i>
----------------	--

<b>WARNING</b>	<i>Ensure that the platform has dimensions and load capacity sufficient for transporting the lift truck.</i>
----------------	--

<b>IMPORTANT</b>	<i>For lift trucks equipped with a turbo-charged I.C. engine, block off the exhaust outlet to avoid rotation of the turbo shaft without lubrication when transporting the vehicle.</i>
------------------	--

#### LOAD THE LIFT TRUCK

- Block the wheels of the platform.
- Fix the loading ramps so that you obtain an angle as little as possible to lift the lift truck.
- Load the lift truck parallel to the platform.
- Park the lift truck (see : 1 - OPERATING AND SAFETY INSTRUCTIONS : DRIVING INSTRUCTIONS UNLADEN AND LADEN).

<https://www.forkliftpdfmanuals.com/>

#### STOW THE LIFT TRUCK

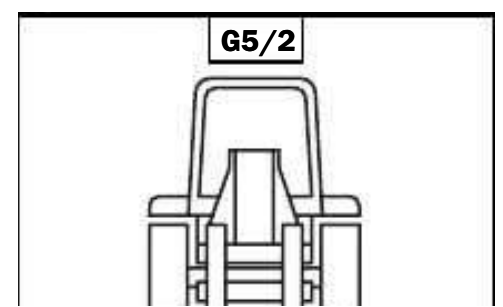
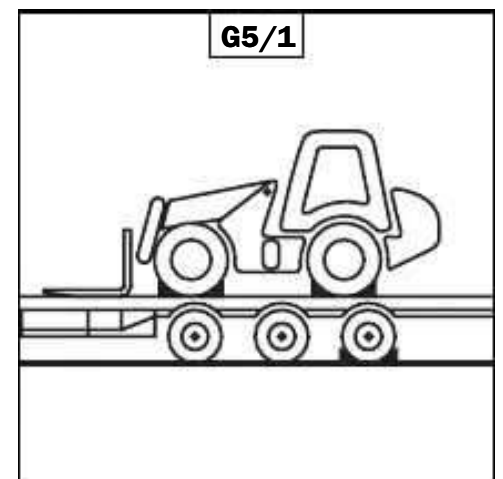

## STOW THE LIFT TRUCK

- Fix the chocks to the platform at the front and at the back of each tire (fig. G5/1).
- Fix also the chocks to the platform in the inside of each tire (fig. G5/2).
- Stow the lift truck on the platform with enough resisting straps/chains. At the front of the lift truck, on the fastening points 1 (fig. G5/3) and at the back, on the towing pin 2 (fig. G5/4).
- Tighten the straps/chains (fig. G5/5).

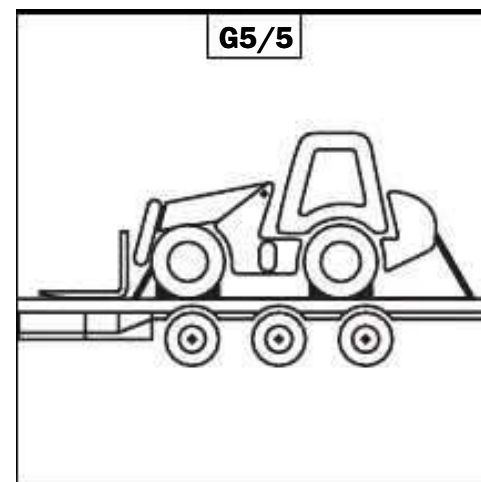

3 - 38

## CONTENTS

### G6 - FRONT HEADLAMPS

#### ADJUST

#### RECOMMENDED SETTING

(as per standard ECE-76/756 76/761 ECE20)

Set to - 2% of the dipped beam in relation to the horizontal line of the headlamp.

#### ADJUSTING PROCEDURE

- Park the lift truck unloaded and in the transport position and perpendicular to a white wall on flat, level ground (fig. G6).
- Check the tire pressures (see : 2 - DESCRIPTION : CHARACTERISTICS).
- Put the gear reverser lever in neutral and release the parking brake.

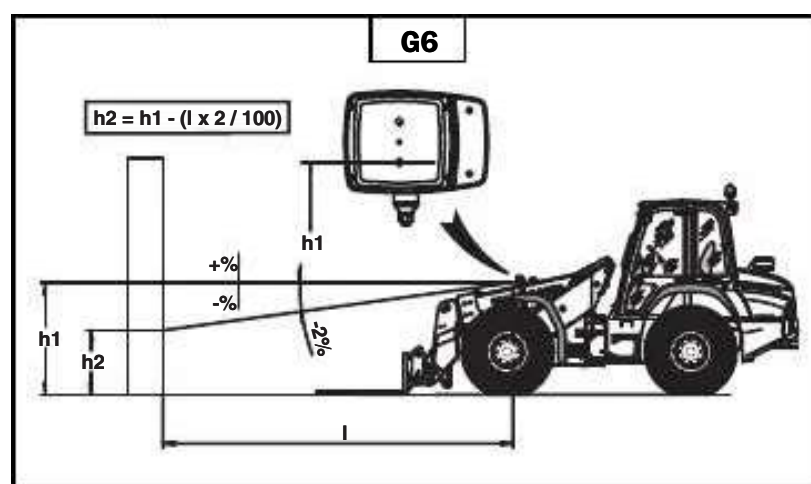

#### CALCULATING THE HEIGHT OF THE DIPPED BEAM (H2)

- h1 = Height of the dipped beam in relation to the ground.

: h2 ≡ Height of the adjusted beam.

: l ≡ Distance between the dipped beam and the white wall.

<https://www.forkliftpdfmanuals.com/>

CONTENTS

## H - EVERY TWO YEARS (OPTION AIR CONDITIONING)



### WARNING

DO NOT ATTEMPT REPAIRS. ONLY A QUALIFIED AIR CONDITIONING SERVICEMAN SHOULD MAKE REPAIRS. CONTACT YOUR DEALER.

- Do not open the circuit under any circumstances as this would cause the coolant to be lost.
- The cooling circuit contains a gas which can be dangerous under certain conditions. This gas, coolant R 134a, is colourless, odourless and heavier than air.



### WARNING

Do not open the cooling circuit under any circumstances, this will cause the coolant to be lost. The cooling circuit contains a gas which can be dangerous under certain conditions. This gas, coolant R 134a, is colorless, odorless and heavier than air.

*If the gas is inhaled, take the victim into fresh air, give oxygen or artificial respiration if necessary and call a doctor. • If the gas is in contact with the skin, wash it immediately under running water and remove any contaminated garments. • If the gas is in contact with the eyes, rinse them in clear water for 15 minutes and call a doctor.*

- The charger has an oil level gauge; never unscrew this gauge because it would depressurise the installation. The oil level is only checked when changing the oil in the circuit



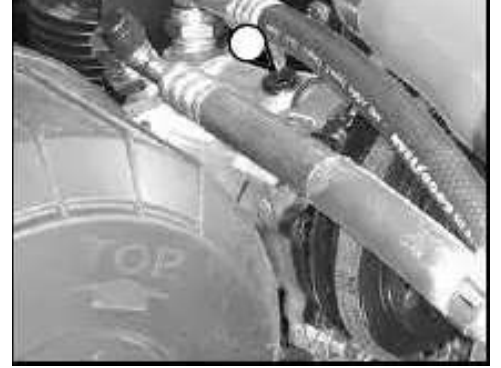

~~**H1 - CLEANING THE CONDENSER AND EVAPORATOR COILS (\*)**~~

---

~~**H2 - CLEANING THE HOTWELL AND THE PRESSURE RELIEF VALVE (\*)**~~

---

~~**H3 - COLLECTING THE COOLANT TO REPLACE THE FILTER-DRIER (\*)**~~

---

~~**H4 - RELOADING COOLANT AND CHECKING THE THERMOSTATIC CONTROL AND PRESSURE SWITCHES (\*)**~~

---

**(\*) : (CONSULT YOUR DEALER).**



4 - 1

CONTENTS

**CONTENTS**

**TABLE OF CONTENTS**

<b><i>INTRODUCTION</i></b>	<b>4 - 5</b>
<b><i>PICKING UP THE ATTACHMENTS</i></b>	<b>4 - 6</b>
<b>A - ATTACHMENT WITHOUT HYDRAULICS AND HAND LOCKING DEVICE</b>	<b>4 - 6</b>
<b>B - ATTACHMENT WITHOUT HYDRAULICS AND HYDRAULIC LOCKING DEVICE (OPTION)</b>	<b>4 - 7</b>
<b>C - HYDRAULIC ATTACHMENT AND HAND LOCKING DEVICE</b>	<b>4 - 8</b>
<b>D - HYDRAULIC ATTACHMENT AND HYDRAULIC LOCKING DEVICE (OPTION)</b>	<b>4 - 9</b>

**4 - 3**

**CONTENTS**

## INTRODUCTION

- Your lift truck must be used with interchangeable equipment. These items are called : ATTACHMENTS.
- A wide range of attachments, specially designed and perfectly suitable for your lift truck is available and guaranteed by MANITOU.
- The attachments are delivered with a load chart concerning your lift truck. The operator's manual and the load chart should be kept in the places provided in the lift truck. For standard attachments, their use is governed by the instructions contained on this notice.
- Some particular uses require the adaptation of the attachment which is not provided in the price-listed options. Optional solutions exist, consult your dealer.

### IMPORTANT

*Only attachments approved by MANITOU are to be used on our lift trucks. The manufacturer's liability will be voided in case of modification(s) without prior written permission.*

*Maximum loads are defined by the capacity of a lift truck taking into account the attachment's mass and center of gravity. In the event of the attachment having less capacity than the lift truck, never exceed its limit.*

<https://www.forkliftpdfmanuals.com/>

 **WARNING**

Depending on their size, certain attachments (when the boom is lowered and/or retracted, or the tilt is activated) may come into contact with the front tires and cause damage to them. TO AVOID TIRE DAMAGE, EXTEND THE TELESCOPE TO A SUFFICIENT DISTANCE TO AVOID DAMAGING THE TIRES!

## PICKING UP THE ATTACHMENTS

### **A - ATTACHMENT WITHOUT HYDRAULICS AND HAND LOCKING DEVICE**

#### **TAKING UP AN ATTACHMENT**

- Ensure that the attachment is oriented for locking to the carriage. If it is not correctly oriented, take the necessary precautions in order to move it safely.
- Check that the locking pin and the clip are in position in the bracket (fig. A).
- Park the lift truck with the boom lowered in front of and parallel to the attachment, tilt the carriage forwards (fig. B).
- Bring the carriage under the locking tube of the attachment, slightly lift the boom, incline the carriage backwards in order to position the attachment (fig. C).
- Lift the attachment off the ground to facilitate locking.

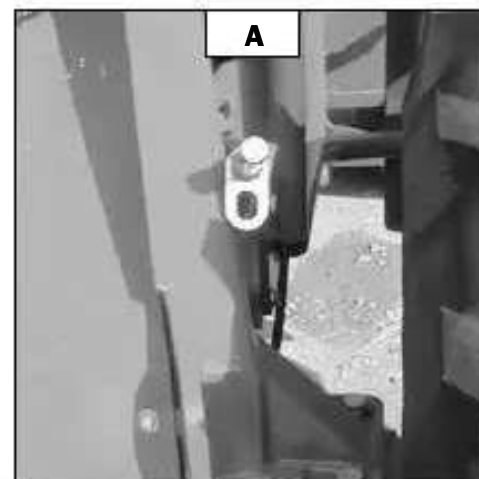

#### **HAND LOCKING**

- Take the locking pin and the clip on the bracket (fig. A) and lock the attachment (fig. D).

Do not forget to install the clip.

#### **HAND RELEASING**

- Proceed in the reverse order of paragraph HAND LOCKING while making sure you install

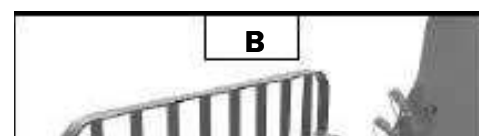

- Proceed in the reverse order of paragraph HAND LOCKING while making sure you install the locking pin and the clip in the bracket (fig. A).

### LAYING AN ATTACHMENT

- Proceed in the reverse order of paragraph TAKING UP AN ATTACHMENT while making sure you place the attachment flat on the ground and in closed position.

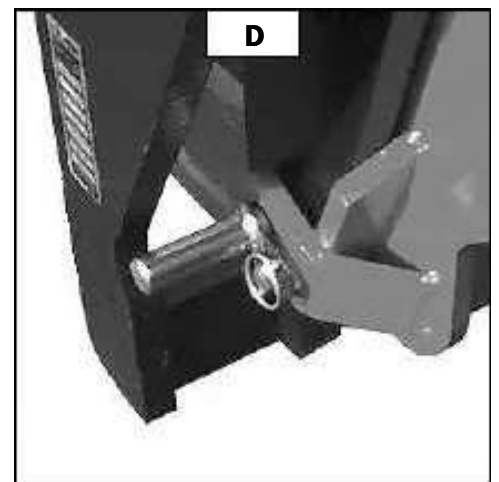
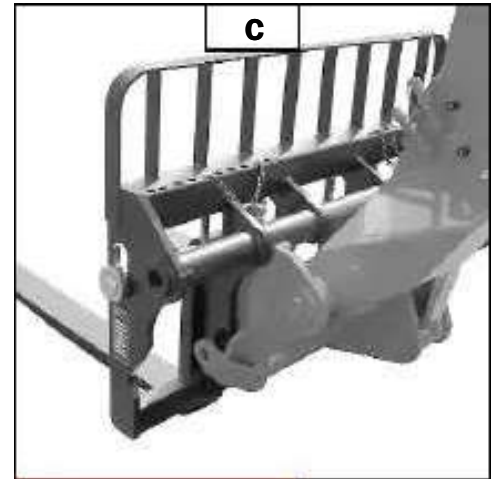

## CONTENTS

### **B - ATTACHMENT WITHOUT HYDRAULICS AND HYDRAULIC LOCKING DEVICE (OPTION)**

MLA 628 -120 LSU POWERSHIFT Series 3-E2

#### TAKING UP AN ATTACHMENT

- Ensure that the attachment is oriented for locking to the carriage. If it is not correctly oriented, take the necessary precautions in order to move it safely.
- Check that the rods on the locking cylinder are retracted (fig. A).
- Park the lift truck with the boom lowered in front of and parallel to the attachment, tilt the carriage forwards (fig. B).
- Bring the carriage under the locking tube of the attachment, slightly lift the boom, incline the carriage backwards in order to position the attachment (fig. C).
- Lift the attachment off the ground to facilitate locking.

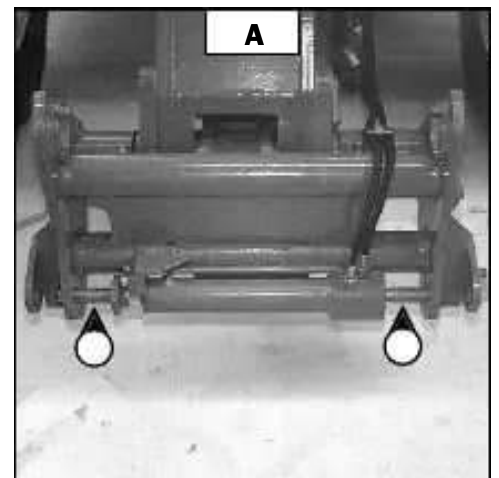

#### HYDRAULIC LOCKING

- Put the valve in position A (fig. D), the hydraulic circuit of the attachment locking open.
- Switch button 1 (fig. E) of the distributor lever up to completely lock the attachment on the carriage.
- Close the valve in position B (fig. D), the hydraulic circuit of the attachment locking closed.

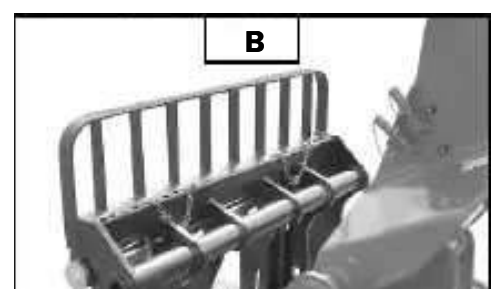

**WARNING** Always close the valve in position B (fig. D) after locking the attachment, to

**WARNING**

avoid accidental unlocking!

**HYDRAULIC RELEASING**

- Put the valve in position A (fig. D), the hydraulic circuit of the attachment locking open.
- Switch button 1 (fig. E) of the distributor lever down to completely release the attachment.

**LAYING AN ATTACHMENT**

- Proceed in the reverse order of paragraph TAKING UP AN ATTACHMENT while making sure you place the attachment flat on the ground and in closed position.

**INACTIVATE THE HYDRAULIC RELEASE CONTROL**

You can change an attachment without leaving the control post, by cutting the electricity supply to the hydraulic control.

- Leave the valve in position A (fig. D).
- Use switch 2 (fig. F) to cut the electricity supply to the hydraulic control. The circuit is out of action when indicator 3 (fig. F) is on.

**WARNING**

Always cut the electrical power to the circuit using switch 3 (fig. F) after each change of attachment to avoid involuntary release!

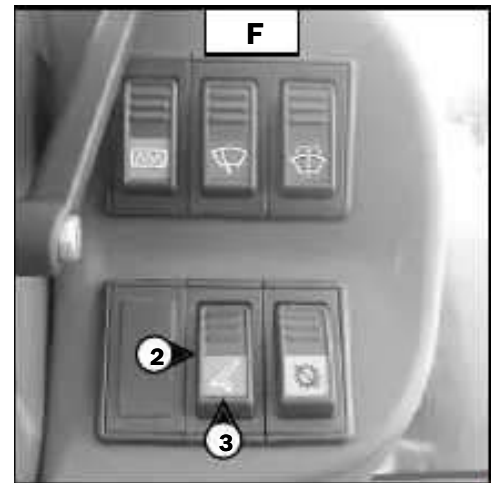
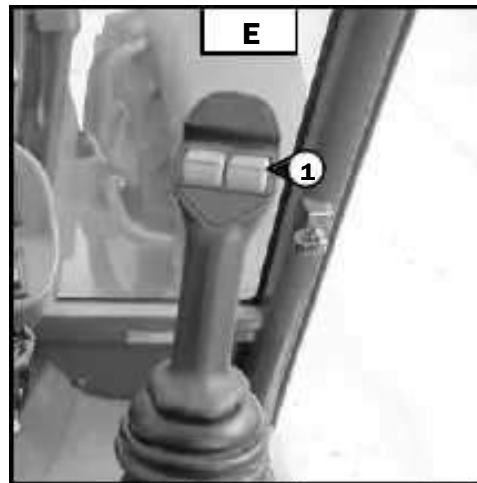
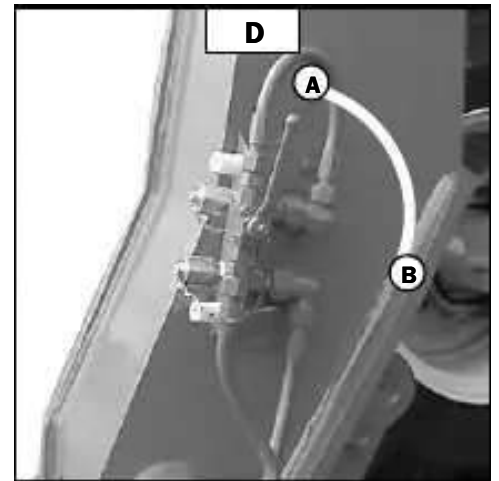
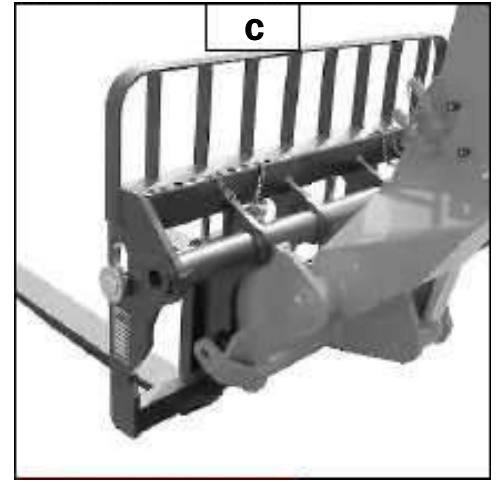

4 - 7

**CONTENTS****C - HYDRAULIC ATTACHMENT AND HAND LOCKING DEVICE**

MLA 628 -120 LSU POWERSHIFT Series 3-E2

**TAKING UP AN ATTACHMENT**

- Ensure that the attachment is oriented for locking to the carriage. If it is not correctly oriented, take the necessary precautions in order to move it safely.
- Check that the locking pin and the clip are in position in the bracket (fig. A).
- Park the lift truck with the boom lowered in front of and parallel to the attachment, tilt the carriage forwards (fig. B).
- Bring the carriage under the locking tube of the attachment, slightly lift the boom, incline the carriage backwards in order to position the attachment (fig. C).
- Lift the attachment off the ground to facilitate locking.

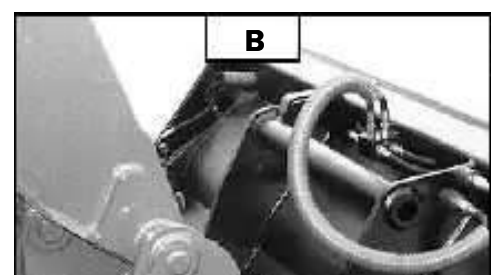
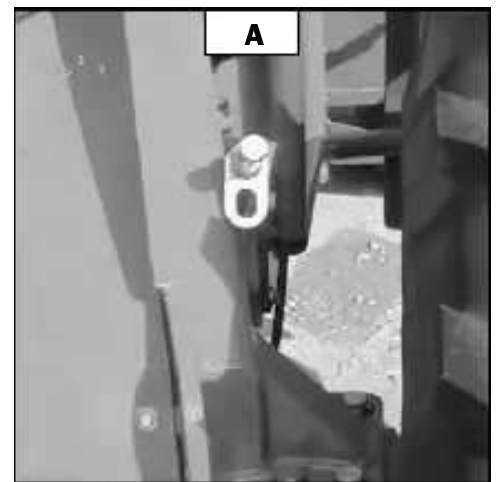
**HAND LOCKING AND CONNECTING THE ATTACHMENT**

- Take the locking pin and the clip on the bracket (fig. A) and lock the attachment (fig. D). Do not forget to install the clip.
- Stop the I.C. engine and keep the ignition on the lift truck.
- Release the pressure from the attachment hydraulic circuit by pressing button 1 (fig. E) on the distributor lever up and down 4 or 5 times.
- Connect the rapid connectors according to the logic of the attachment's hydraulic movements.

## IMPORTANT

Make sure that the rapid (quick-release) connectors are clean and protected with the caps provided when not in use.



### HAND RELEASING AND DISCONNECTING THE ATTACHMENT

- Proceed in the reverse order of paragraph HAND LOCKING AND CONNECTING THE ATTACHMENT while making sure you install the locking pin and the clip in the bracket (fig. A).

### LAYING AN ATTACHMENT

- Proceed in the reverse order of paragraph TAKING UP AN ATTACHMENT while making sure you place the attachment flat on the ground and in closed position.

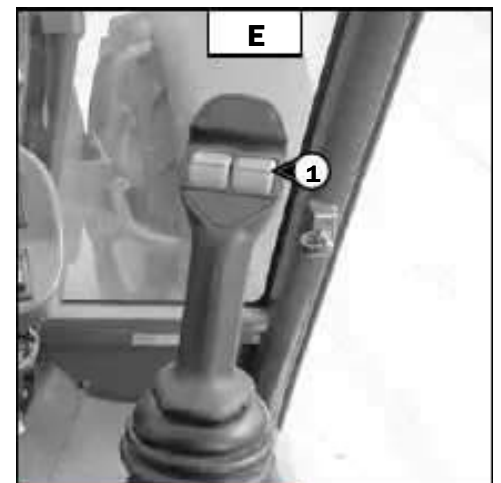
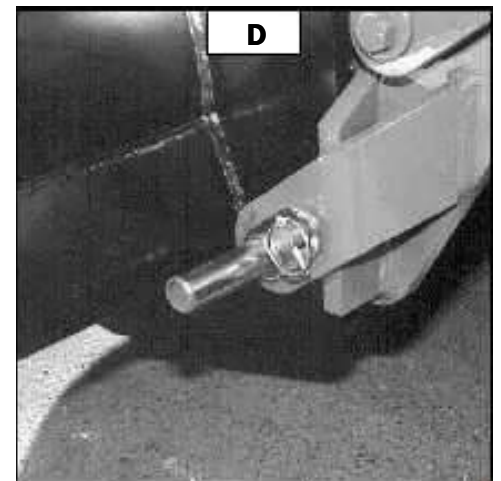
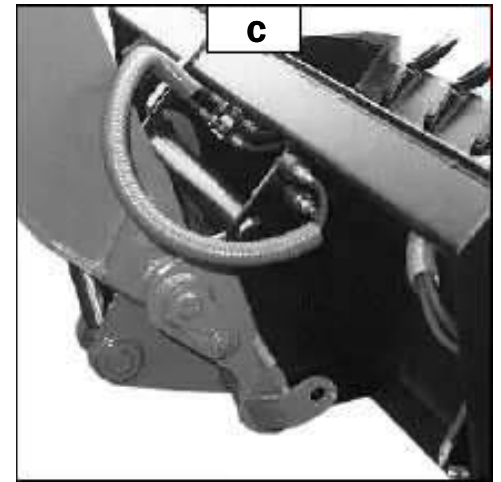

4 - 8

## CONTENTS

### D - HYDRAULIC ATTACHMENT AND HYDRAULIC LOCKING DEVICE (OPTION)

MLA 628 -120 LSU POWERSHIFT Series 3-E2

#### TAKING UP AN ATTACHMENT

- Ensure that the attachment is oriented for locking to the carriage. If it is not correctly oriented, take the necessary precautions in order to move it safely.
- Check that the rods on the locking cylinder are retracted (fig. A).
- Park the lift truck with the boom lowered in front of and parallel to the attachment, tilt the carriage forwards (fig. B).
- Bring the carriage under the locking tube of the attachment, slightly lift the boom, incline the carriage backwards in order to position the attachment (fig. C).
- Lift the attachment off the ground to facilitate locking.

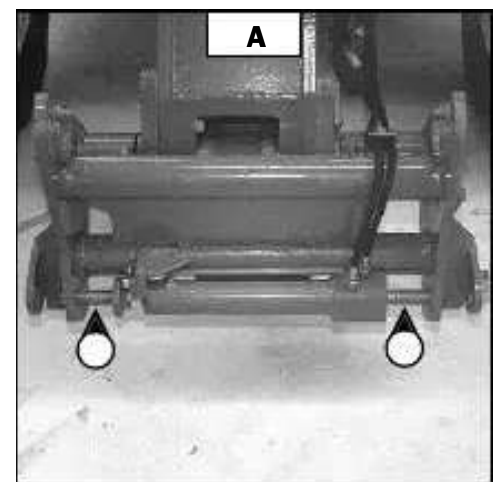

#### HYDRAULIC LOCKING AND CONNECTING THE ATTACHMENT

- Put the valve in position A (fig. D), the hydraulic circuit of the attachment locking open.
- Switch button 1 (fig. E) of the distributor lever up to completely lock the attachment on the carriage.
- Stop the I.C. engine and keep the ignition on the lift truck.

- Release the pressure from the attachment hydraulic circuit by pressing button 1 (fig. E) on the distributor lever up and down 4 or 5 times.
- Connect the rapid connectors according to the logic of the attachment's hydraulic movements.

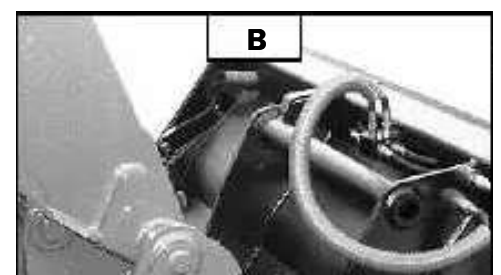



ments.

### IMPORTANT

*Make sure that the rapid (quick-release) connectors are clean and protected with the caps provided when not in use.*

- Close the valve in position B (fig. D), the hydraulic circuit of the attachment locking closed.



### WARNING

*Always close the valve in position B (fig. D) after locking the attachment, to avoid accidental unlocking!*

### HYDRAULIC RELEASING AND DISCONNECTING THE ATTACHMENT

- Close the attachment.
- Put the valve in position A (fig. D), the hydraulic circuit of the attachment locking open.
- Switch button 1 (fig. E) of the distributor lever down to completely release the attachment.
- Stop the I.C. engine and keep the ignition on the lift truck.
- Release the pressure from the attachment hydraulic circuit by pressing button 1 (fig. E) on the distributor lever up and down 4 or 5 times.
- Disconnect the rapid connectors of the attachment.

### IMPORTANT

*Make sure that the rapid (quick-release) connectors are clean and protected with the caps provided when not in use.*

### LAYING AN ATTACHMENT

- Proceed in the reverse order of paragraph TAKING UP AN ATTACHMENT while making sure you place the attachment flat on the ground and in closed position.

