



Electric forklift truck

Linde Material Handling

The Linde logo, consisting of the word "Linde" in a white, cursive script font, is positioned in the bottom right corner of a red rectangular area.

Original instructions

335-03 series

E16C-03, E16P-03,
E20P-03

335 801 1701 EN – 04/2014

Linde – Your Partner



With over 100,000 fork lift trucks and warehouse machines sold annually, Linde is one of the world's leading manufacturers of material handling equipment. There are many reasons for this success: Linde products are renowned not only for their innovative, cutting-edge technology, but also for their low energy and operating costs, which are up to 40 per cent lower than those of their competitors.

The high quality of Linde products is also matched by the quality of our service. With ten production plants worldwide and an extensive network of sales partners, we are at your service round the clock and around the world.

Your local Linde partner can offer you a complete package from a single source; ranging from expert advice on all aspects of sales and service through, of course, to appropriate finance options. Our leasing, hire or lease-purchase agreements provide you with the flexibility to tailor decision-making to your individual business requirements.

Linde Material Handling GmbH
Carl-von-Linde-Platz
63743 Aschaffenburg
Telephone +49 (0) 6021 99-0
Fax +49 (0) 6021 99-1570
Mail: info@linde-mh.com
Web: <http://www.linde-mh.com>

1	Introduction	
	Introduction	2
	Intended use	5
	Impermissible use	6
	Description of use and climatic conditions	
	Symbols used	7
	Technical description	7
	EC declaration of conformity	10
2	Safety	
	Safety guidelines	14
	Residual risks	15
	Stability	16
	In the case of tip-over	
	Handling consumables	16
	Qualified person	17
	Regulations	17
	Fit attachments	18
	Emergency exit with attached rear window	20
	Manually tilting the mast and lowering the fork	21
	Do not use cables to open the overhead guard by force	23
3	Overview of the forklift truck	
	Identification plate	26
	Overview of the forklift truck	28
	Operating devices	29
	Display unit	30
4	Operation	
	Pre-use daily checks and maintenance	36
	Pre-shift checks	36
	Opening the overhead guard	36
	Checking the battery level	40
	Battery change	42

Pre-use daily checks and maintenance	44
Adjusting the driver's seat	45
Emergency off switch	47
Driving	48
Single-pedal operation (optional)	51
Steering system	55
Brake system	56
Operating the lift mast and attachments using the centralised control lever (joy- stick)	58
Single lever operation of the lift mast and attachments	61
Working spotlights*, windscreen wipers*, headlights*, direction indicator lights*	63
Horn, electrical system cover	65
Fuses	66
Before loading	68
Loading	70
Tow coupling	72
Truck transport	73
Towing regulations	73
Carrying and lifting the forklift truck	74
Wheel change	76
Use in cold stores	78
Truck storage	80
Taking the forklift truck out of operation	80
Disposal of old trucks	82
5 Maintenance	
Summary	84
Working on the lift mast or front section of the fork lift truck	85
Inspection and maintenance parameters	88
Recommended lubricants	89
1000 hour maintenance plan	91
3000 hour maintenance plan	93
Reduction gearbox	96
Checking the wheel gear oil level	96
Checking whether the speed reduction gearbox is leaking	96

Cleaning both sides of the traction motor, the power steering and working hydraulic pump motor	97
Replacing the gear oil in the speed reduction gearbox	97
Frame and installation	100
Checking the counterweight, motors, chassis, speed reduction gearbox, overhead guard and steering axle fastenings	100
Lubricating the overhead guard pin shaft	100
Checking and lubricating other pins and swivel points	101
Checking the status of the anti-static belts* (only for trucks fitted with super clean tyres)	101
Chassis frame	102
Check the brake system	102
Tighten the wheel nuts	104
Cleaning/lubricating the steering axle	105
Replacing the brake fluid	106
Operating devices	107
Checking the joystick pad	107
Checking and lubricating the pedal mechanisms, control linkage mechanisms and the overhead guard locking devices	107
Electrical system	108
Checking the status and tightness of the electrical cables, electrical connections and plug connectors	108
(As required) Clean the power modules of the traction and lift controls, the fans and the radiator housing with compressed air	109
Cleaning the digital control cables	110
Inspect the contactor contacts, and replace if necessary	111
Hydraulic system	111
Check the hydraulic oil level	111
Checking the leak resistance of the working and steering hydraulic systems	113
Replacing the air, pressure and suction filters	113
Replacing the hydraulic oil (if it is Bio hydraulic oil, the Aral Forbex SE46 is 6000operating hours)	115
Load lift system	117
Checking the condition, tightness and function of the lift mast, lift chains and stop block	117
Adjusting the length of the lift chains, and lubricating using chain spray	118
Checking the truck's releasing and locking equipment	119

6 Technical data

List of technical parameter marks	122
Technical parameters – E16P forklift	123
Technical parameters – E16P forklift	126
Technical parameters – E20P forklift	129
Lift mast data	131

Annex

7 Circuit diagrams

Electrical circuit diagram	142
Circuit diagrams	142
Circuit diagrams	144
Circuit diagrams	145
Hydraulic oil diagram	146
Working and steering hydraulic system circuit diagrams	146
Working and steering hydraulic system circuit diagrams	148

Introduction

Introduction

Your Linde forklift truck

With maximum economic efficiency, safety and driving comfort. Yet, it is up to you, the forklift truck operator, to take good care when

working and use its potential to the fullest. During the manufacturing process (if affixed with CE mark):

- We adhered to all CE safety requirements.
- We carried out all compliance tests required by law.

This is proven by the CE stamp shown on the identification plates.

The manual provides you important information on activating, driving, operating and maintaining a Linde forklift truck.

Please regularly complete the maintenance checklists and make sure it is done on time. Use the tools, cleaning products etc. specified.

In order to maintain valid warranty service for your forklift truck, please keep and save a complete, detailed record of the maintenance process.

All maintenance procedures must be recorded; otherwise you will lose the warranty.

Users, especially forklift truck drivers and maintenance personnel, must strictly adhere to GB 10827-1999 regulations.

Users, especially forklift truck drivers and maintenance personnel, must strictly follow "Guidelines on correct and safe use of materials handling equipment" and BITA guidelines. (Overseas edition)

User shall be responsible for any loss caused by improper use. Manufacturer Linde, Ltd will not be responsible for such loss.

If you want to use the forklift truck for purposes that are not mentioned in the user manual, please contact dealers accredited by Linde Corp. Ltd.

Any modification of your truck, in particular fitting of equipment or conversion of the truck, is prohibited without the permission of the manufacturer.

Attachment manuals are provided

NOTE

Add a load identification plate for any attachments to the forklift truck.

CAUTION

Taking into account stability and the specified minimum braking distance, do not carry out stacking/de-stacking operations on a slope.

The climbing degrees in the model parameters table are ascertained from the forklift truck traction, and only apply when going over small obstacles and driving on relatively flat surfaces.

Technical notes

This user manual must not be copied, translated or sent to a third party without the manufacturer's written consent.

Linde Corp., Ltd's business philosophy is to constantly improve its products in terms of design and structure. Hence, Linde reserves the right to change a forklift truck's design and technical parameters at any time.

Hence, the company may refuse to take responsibility for any complaint with respect to the technical parameters, illustrations, and instructions of this user manual.

Forklift trucks with accessories delivered from the factory come with accessory operating instructions. Before starting forklift trucks with accessories, you must ensure that goods have been stabilized. You may need to make adjustments according to accessory type, such as adjustments to pressure settings or to stoppers and operating speeds. For the relevant instructions, please refer to the accessory operating instructions. Accessories must be used in compliance with the accessory operating instructions.

Use dedicated work supplies according to checking and maintenance overviews. Perform specified work regularly at the anticipated time. To comply with warranty conditions, please ensure that work carried out is recorded in the registration documents for the industrial forklift truck.

The designations used in the text (front, back, left, right) always refer to the installation position of the parts described, with a forward drive direction of the truck (fork arms forwards).

Servicing work not described here will require specialist knowledge, measuring devices and often also special tools. Please contact an authorized dealer to carry out this work.

Servicing should only be carried out by qualified personnel approved by Linde (specialists).

For questions about the forklift truck and orders for spare parts, please contact your local Linde dealer and leave an accurate shipping address.

In order to maintain the original technical efficiency of the forklift truck, please use authentic Linde spare parts when repairing.

When ordering spare parts, please provide the following information in addition to the part numbers:

Forklift model number:

Serial number/Year of manufacturing:

Delivery date:

Part numbers should be specified when ordering parts.

Part number of the lift mast:

Lifting height of the lift mast [mm]:

When taking delivery of the forklift truck, please copy data from the components' identification plate details into this user manual.

You may find the relevant information on the identification plate of the forklift truck. We recommend you write down the information in this manual for future reference.

Forklift truck handover

Before leaving the factory, every forklift truck must be carefully examined so that it is completely up to standard and can be delivered to the user in perfect condition.

In order to guarantee the forklift truck works correctly, Linde dealers are obliged to check

the following items before the handover:

Check whether the driving wheel nuts are tightened

Check the battery status

Checking the hydraulic oil level

Check the braking function

Check the steering function

Check the traction function

Check the mast lift and attachments operating function

In order to avoid the inconvenience of claims after use, please check that the forklift truck is in perfect condition and state of repair, and

confirm your satisfaction with the forklift truck on the manufacturer's product qualification certificate upon handover.

NOTE

When a forklift truck with attachments leaves the factory, operating instructions for the attachments should be provided along with the vehicle.

NOTE

Every forklift truck is provided with the following technical documents:

1 Introduction

Introduction

- Operating instructions for the truck
- Spare parts manual
- Operating instructions for the attachments (only applies to trucks delivered from the factory with attachments)
- VDMA (EU countries only)
- EC Declaration of Conformity (applicable for CE certified forklift trucks)

Intended use

The industrial truck may only be used as permitted.

The industrial truck is used for moving and lifting the loads indicated on the capacity rating plate.

Damages and defects

Damages and other defects to industrial trucks or to attachments must be reported to the Supervisor immediately. Industrial trucks and attachments which are not safe to operate may not be used until they have been properly repaired.

Safety installations and switches may not be removed or rendered unusable. Specified settings may only be changed with the approval of the manufacturer.

Danger areas

Danger areas are those areas in which persons are in danger as a result of the movements of industrial trucks, their operating equipment, their load carrying devices (e.g. their attachments) or the loaded goods. This also includes the area which can be reached by falling goods or lowering or falling operating equipment and devices.

People must not stand in the danger area of an industrial truck.

Working areas

Only the areas approved by the operating company or its representative may be used for transportation purposes. Loads may only be deposited or stored at the intended places.

Driving routes

Driving routes shall be sufficiently paved, level and free of objects. Drain channels and railways crossings, etc., shall be levelled and, if necessary, covered with ramps in such a way that they can be driven over without bumps as far as possible.

Industrial trucks shall only be used on routes without sharp curves, excessive slopes and gates which are too narrow or too low.

Inclines used by industrial trucks shall not exceed the limits specified by the manufacturer and must have an adequately rough surface.

Level and smooth transitions at the upper and lower end shall prevent the load from touching the floor or causing damages to the chassis.

The admissible area and point load of driving lanes or routes may not be exceeded. There shall be an adequate clearance between the highest parts of industrial trucks or the load and the fixed parts of the surrounding areas.

The EU Directive 89/654/EEC (Minimum Regulations for Health and Safety at Work) shall be observed. The respective national regulations apply for non-EU countries.

Danger points on driving lanes or routes shall be secured or marked by the customary road traffic signs and by additional warning signs, if necessary.

When driving on public roads, the corresponding regulations must be observed, as well as country-specific restrictions for winter road conditions.

Fire protection

The operating company is responsible for adequate fire protection in the vicinity of the industrial truck. Depending on the form of use, it is responsible for additional fire protection on the industrial truck. Enquiries should be directed to the responsible supervisory authority in case of doubt.

Attachments

Attachments shall only be used as permitted. The driver shall be instructed in the handling of attachments.

The attachment operating instructions are enclosed for trucks that are delivered from the factory with an attachment. Before commissioning a truck with an attachment, you must

1 Introduction

Impermissible use

check that loads are handled securely. Depending on the type of attachment, it may be necessary to make adjustments, e.g. pressure settings or adjusting stops and operating speeds. See the attachment operating instructions for the corresponding instructions.

If attachments are not supplied with the industrial truck, the specifications of the industrial truck manufacturer and the attachment manufacturer must be observed.

The attachments and the connection of power supplies for powered attachments may only be made by specialists in accordance with the specifications of the manufacturer. The proper functioning of the attachments shall be checked after each installation before initial use.

The permissible carrying capacity of the attachments and the permitted load of the industrial truck (carrying capacity and load

moment) combined with the attachments shall not be exceeded. , refer to additional capacity rating plate.

Modifications, in particular attachments or conversions, are not permitted to be made to the industrial truck without the manufacturer's approval.

Trailers

Industrial trucks may only be used to tow trailers if they are intended for this purpose by the manufacturer and if they are fitted with the appropriate trailer coupling. The maximum towed load specified in the operating instructions for unbraked or braked trailers must not be exceeded.

The towing industrial truck must be operated in such away that safe driving and braking of the towed vehicle is ensured for all driving movements.

Impermissible use

▲ DANGER

High risk of property damage, injury and death.
Avoid impermissible use.

The operating company or driver, and not the manufacturer, is liable if the truck is used in a manner that is not permitted.

The following list is exemplary and is not intended to be exhaustive.

It is not permitted:

- To use the truck to transport people (if the truck is not designed for this purpose)
- in areas where there is a risk of fire or explosion
- for stacking/unstacking operations on slopes
- To stand on the fork arms when raised
- To exceed the truck's maximum load capacity
- To increase the truck's load capacity, e.g. by attaching an additional weight.

Description of use and climatic conditions

Normal use

- Indoor and outdoor use
- Ambient temperature in tropical and Nordic regions ranging from -10 °C to 40 °C
- Use at up to 2000 metres above sea level.

Special use (partly with special measures)

- Ambient temperature in tropical regions to 40 °C
- Cold store version to -32 °C

Symbols used

The terms DANGER, WARNING, CAUTION, NOTE and ENVIRONMENT NOTE are used in these operating instructions for notes on particular hazards or for unusual information that needs to be highlighted:

DANGER

Means that failure to comply can cause risk to life and/or major damage to property.

WARNING

Means that failure to comply can cause risk of serious injury and/or major damage to property.

CAUTION

Means that failure to comply can cause risk of material damage or destruction.

NOTE

Means that particular attention is drawn to combinations of technical factors which may not be evident even to a specialist.

ENVIRONMENT NOTE

The instructions listed here must be complied with as otherwise environmental damage may result.



CAUTION

This label is found on the truck in the areas where particular care and attention are required.

You should refer to the appropriate section in these operating instructions.

For your safety, additional symbols are also used. Please heed the various symbols.

Technical description

The corresponding maximum load for the 335-3 Series battery forklift E16C, E16P is 1.6

tons; the corresponding maximum load for the E20P is 2.0 tons.

1 Introduction

Technical description

NOTE

Refer to the safe working load diagram for the centre of gravity data.

Open structure cabin designed according to the latest engineering techniques, energy saving control system (LDC) as standard, ensuring the value for money of the truck's equipment. Its features include its compactness, excellent visibility, optimum stability on sharp turns and cornering stability. These advantages all benefit from the truck's various different wheel bases.

The electric forklift truck is available with two different steering axle designs:

Compact steering axle
Model no. E 16C

The compact steering axle has a low consumption, and tyre wear is minimal due to the mutual compensation of the dual rear wheels. The body width is small, and the steering is light and flexible, making it especially suitable for working in narrow spaces.

Compound steering axle
E 16P, E20P

The compound steering axle ensures that the entire axle has a larger swing range, stronger grip and increased driving safety, making it

especially suited to operating on uneven road surfaces.

The truck has an electrical towing device, in addition to a motor and hydraulic pump used to provide the needed power to the power steering and working hydraulics.

Drive

The truck is driven by two AC motors, which are automatically controlled according to their motor characteristic curve. These two motors drive the right and left transmission, the power from which is then transmitted from the transmission to the wheels.

Electrical power is provided by the storage battery installed inside the truck.

Forward and reverse stepless speed regulation can be carried out extremely lightly by means of the digital traction controller (LDC), operated by the right and left accelerator pedals.

Steering

Operating the truck's steering wheel allows free and easy control of the hydrostatic steering system's steering cylinder, allowing the truck to turn.

Hydraulic equipment

The hydraulic system includes a motor and hydraulic pump that provide power steering, mast lifting and cylinder tilting, and a filter with ventilation. The dipstick and oil-absorption filter and the pressure filter's hydraulic tank.

DANGER

Connecting any device whose safety is at the safety critical point to the third auxiliary hydraulic manifold is strictly prohibited. These safety critical point devices, such as oil drum clamps or rotary devices, may cause inadvertent misuse of the clamps, or rotation.

If a device located at the safety critical point must be connected to the third auxiliary hydraulic manifold, then this device must first pass the third auxiliary manifold and then be connected.

Operation

The traction motor is controlled by the forward and reverse travel pedals. Both forward and reverse speeds can be regulated steplessly from rest to maximum speed. Both hands can be used specifically for steering operation and its auxiliary operation, enabling rapid direction reversal and high-efficiency stacking. The lifting, lowering and tilting of goods can be controlled by using just one operating lever (centralised joystick). The truck's attachments can be controlled by the other operating lever.

Another operating lever (joystick) can be fitted to operate additional attachments.

If desired, all work devices (lifting, lowering and tilting) can also be controlled by individual operating levers.

Brake

The truck has multiple independent braking systems. These braking systems can be divided into electrical brakes and hydraulic brakes, as well as the parking brake. Depressing the brake pedal activates the hydraulic servo, in order to control the multi-disc brakes in the drive unit axle.

When the driver reverses direction and depresses the accelerator pedal, the truck produces electric braking (regenerative braking).

This truck provides an energy feedback system as a standard device. When braking, or when the driver changes the direction of movement, the energy is transformed into electrical energy and recharges the storage battery.

When the accelerator pedal is released, the truck performs electrical braking by means of the Linde braking controls (LBC). If required,

a diagnostic unit can be used to cancel LBC braking.

NOTE

After cancelling LBC braking, a 'No LBC braking' label must be stuck in a place that will be easily seen by the driver. Please contact your Linde dealer for assistance.

Parking brake

The multi-disc brakes in the drive unit axle can be controlled by manually pulling on the parking lever.

Electrical system

The electrical system is mounted in the counterweight. The needed power is provided by a 48 V rechargeable battery mounted in the chassis. The lifting overhead guard guarantees rapid replacement of the rechargeable battery.

NOTE

The housing of electrical parts must not be opened during the warranty period or the terms of the warranty will be void.

EC declaration of conformity

Declaration

Linde (China) Forklift Truck Corp. Ltd
No. 89 Jinshang Road, Xiamen 361009
Xiamen, P.R.China

We declare that the

Industrial truck	according to these operating instructions
Model No. E16C, E16P, E20P, 335-03 series	according to these operating instructions

complies with the most recent version of machinery directive 2006/42/EC.

Personnel authorised to compile the technical documents:

see EC declaration of conformity

Linde (China) Forklift Truck Corp. Ltd

Manufacturer's declaration on the forklift truck's compliance to EC code comes into effect upon its sale. This can be verified by the EC compliance declaration and CE label on the identification plate. See the above statement.

Unauthorised modification or additional installation of equipment to the structure of the forklift truck may affect its safety, and therefore will invalidate the EC compliance declaration.

The EC compliance declaration must be carefully conserved and kept ready to be presented to the relevant authorities.



1 Introduction

EC declaration of conformity

2

Safety

Safety guidelines

The "Rules for proper use of industrial trucks" supplied with these operating instructions must be brought to the attention of the persons responsible, in particular to those persons concerned with operating and maintaining the industrial trucks, before working with or on the trucks.

The operating company must ensure that the driver understands all the safety information.

Please observe the directives and guidelines listed, e.g.

- Operation of industrial trucks,
- Driving licences,
- Rules for driveways and the area of operation,
- Driver rights, duties and rules of behaviour

- Special operating areas
- Information regarding setting off, driving and braking
- Information for maintenance and repair
- Periodic checks,
- Disposal of greases, oils and battery,
- Residual risks.

As the operating company or responsible person, ensure that all directives and safety guidelines that are applicable to your industrial truck are complied with.

When training a forklift truck driver who has already been trained to BGV D 27 standard, the following must be practised sufficiently by training, driving, switching and steering, so that they are fully mastered:

- The special features of the Linde forklift truck (dual-pedal control, central control lever (joystick), stop pedal),
- Any special equipment for attachments
- Peculiarities of operation and the working area

Only then should training exercises in the racking commence.

Safety information

▲ DANGER

The truck must not be used by unauthorised persons.

As the operating company, you must ensure that access to the truck is only possible for authorised personnel.

▲ DANGER

Safety systems (e.g. the seat switch) are there for your safety.

Safety systems - of whatever kind - must never be disabled.

▲ DANGER

Loads should be arranged so that they do not project beyond the edge of the truck loading surface and cannot slip, topple over or fall off.

If necessary, use a load backrest (special equipment).

▲ DANGER

When retrofitting a 3rd auxiliary hydraulic system, using solutions other than those recommended by the truck manufacturer will render CE conformity null and void, and is therefore expressly prohibited.

Trucks may only be retrofitted with a 3rd auxiliary hydraulic system with the approval of the truck manufacturer.

▲ DANGER

It is prohibited for any safety-critical functions such as a bale clamp or the swivel device for a fluid container to be connected to any (toggle-switch-controlled) third auxiliary hydraulic system that may be fitted.

To prevent inadvertent opening of the clamp or swivel device, the additional function should be connected to the first auxiliary hydraulic system.

▲ DANGER

Any additional bores or welding to the overhead guard on the overhead guard will compromise its rigidity.

It is therefore strictly prohibited to drill holes in the overhead guard or to weld to it.

▲ CAUTION

Welding operations on other parts of the truck can cause damage to the electronics.

Therefore, always disconnect the battery and all connections to the electronic controls beforehand.

▲ CAUTION

For ease of operation, various functions on your truck are gas-spring assisted. Gas springs are complex components that contain high internal pressures (up to 300 bar).

They must not be opened under any circumstances, unless you have received specific instructions to do so. In addition, they must only be dismantled when not under compression. Any type of damage, lateral force, tight fastening, temperatures exceeding 80°C, and dirt must be avoided in every environment. Damaged or deformed gas springs must be replaced immediately. Please contact the authorised agent. When necessary, the authorised dealer will relieve the pressure in the gas springs according to regulations. The pressure in the gas springs must be relieved before recycling.

▲ WARNING

When installing the accumulator, attention must be given to the following problems. Incorrect operation of the accumulator will result in serious injury.

Before working on the accumulator, it must be depressurised. Please contact your authorised dealer.

Residual risks

Despite careful work and compliance with all applicable standards and regulations, the possibility of other dangers when using the industrial truck cannot be entirely excluded.

The industrial truck and its possible attachments all comply with current safety regulations. However, even if the truck is used in



▲ WARNING

Depending on the duration of use and operating time, components carrying exhaust gases and exhaust air may become hot.

Therefore wear protective equipment.

▲ WARNING

The industrial truck working area must be adequately lit.

If it is insufficiently lit, working spotlights must be installed. To ensure that the driver can see properly

▲ CAUTION

Various items of special equipment fitted to your truck have the "speed reduction" special function. It is purely an auxiliary function. This means that the driver must not rely solely on the "speed reduction" function during operation.

The driver is always responsible for safe operation.

▲ CAUTION

If the driver has active medical equipment, e.g. pacemakers or hearing aids, may be impaired.

Check with a doctor or the medical equipment manufacturer whether the equipment is sufficiently protected against electromagnetic interference.



NOTE

If the forklift truck is equipped with a fire extinguisher, please ensure that you are familiar with how to use it in an emergency situation. Relevant handling information is provided on the fire extinguisher.

the proper way and all related instructions are followed, it is impossible to avoid a certain number of residual risks.

Apart from the relatively small range of hazards associated with the truck itself, there are also some unavoidable residual risks. In order to be able to react immediately in the event of

Stability

errors, accidents or malfunctions, personnel involved in working with the truck must practise to raise their awareness levels.

▲ DANGER

Persons in the vicinity of the industrial truck must be instructed with regard to the dangers that arise through use of the truck.

These operating instructions also contain additional safety regulations.

Residual dangers can include:

- Escape of consumables due to leakages or the rupture of lines, hoses or containers,
- Risk of accident when driving over difficult ground such as gradients, smooth or irregular surfaces, or with poor visibility,
- Risk of falling, tripping, slipping etc. during movement of the industrial truck, (especially in the wet, with leaking consumables or on icy surfaces),
- Risk of fire and explosion due to the battery and electrical voltages,
- Human error,
- Disregarding the safety regulations,
- Risk caused by unrepaired damage,
- Risk caused by insufficient maintenance or testing,
- Risk caused by using the wrong consumables.

Stability

Stability is guaranteed if the industrial truck is used correctly according to specified targets. Common reasons for a lack of stability in industrial trucks include:

- Cornering at excessive speeds
- moving with the load raised,
- Moving with a load that is protruding to the side (e.g. side shift)
- turning and driving diagonally across gradients,
- driving on gradients with the load on the downhill side,
- Loads that are too wide
- swinging loads,
- Ramp edges or steps

In the case of tip-over



d3921101

- Stay buckled up
- Don't jump
- Hold on tight
- Brace feet
- Lean away

The stability of your industrial truck is ensured if used properly and as intended. Should the industrial truck tip over during an unapproved application or due to incorrect operation, always follow the instructions depicted above.

Handling consumables



ENVIRONMENT NOTE

Consumables must be handled properly and in accordance with the manufacturer's instructions.

- Consumables should only be stored in containers complying with applicable regulations and at the locations stipulated.
- Do not bring flammable consumables into contact with hot objects or a naked flame.
- When topping up consumables, use only clean containers.
- Observe the manufacturer's instructions relating to safety and disposal.
- Avoid spilling.
- Remove any spilled fluid immediately with a suitable binder and dispose of it according to applicable regulations.
- Old and contaminated operating materials should be disposed of according to the regulations.

- Comply with the statutory provisions.
- Before performing greasing, filter changes or any work on the hydraulic system, carefully clean the area around the part involved.
- Dispose of used spare parts in an environmentally friendly manner.

▲ WARNING

The penetration of pressurised hydraulic fluid into the skin, e.g. due to leakage, is hazardous. If an injury of this type occurs, always consult a doctor.

Protective equipment must be worn.

▲ WARNING

The improper handling of coolant and coolant additives presents a risk to health and the environment.

Observe the manufacturer's instructions without fail.

Qualified person

A specialist is considered to be someone whose technical training and experience have enabled them to develop a sufficient depth of knowledge regarding industrial trucks and who is sufficiently familiar with the applica-

ble national occupational health and safety regulations, accident prevention regulations, directives and generally recognised techni-

cal conventions (standards, VDE regulations, technical regulations of other EU member states or other countries that are signatories to the treaty establishing the European Economic Area) in order to be able to assess the

condition of industrial trucks in terms of health and safety.

Regulations

Regular safety inspection

Periodic safety inspections are essential in order to keep your truck / industrial truck safe and in good working order.

Observe the national regulations for your country.

Europe: Provisions of national law based on Directives 95/63/EC, 99/92/EC and

2 Safety

Fit attachments

2001/45/EC require that the forklift truck/industrial truck is checked regularly by a competent person to ensure it is in good condition.

Germany: Ordinance on Industrial Safety and Health (BetrSichV).

China: National Standards of the People's Republic of China GB 10827-1999.

The European Federation of Materials Handling FEM 4.004 proposed recommendations regarding inspection scope. It defined an inspection mark to record the current inspection, as well as an adhesive label to be used for the next inspection. The next check is shown by the year (3), located on the adhesive label (2), and the colour of the adhesive label (1) varies every year. The inspection scope is expanded by Linde according to the specific category of forklift truck. Please contact your authorised dealer to perform this task.

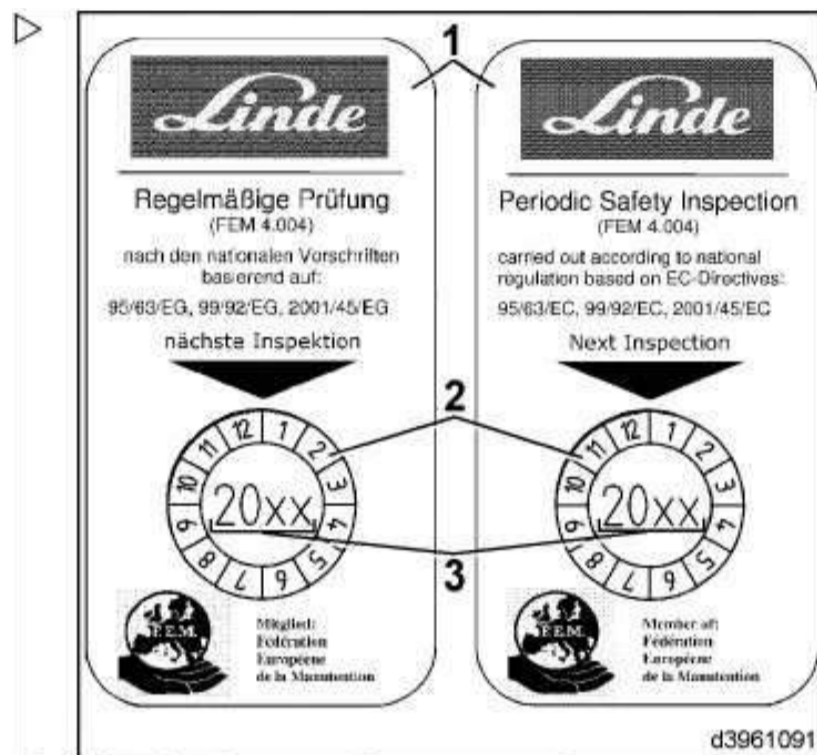

Fit attachments

Only specialists are permitted to fit the attachment and connect the energy supply for power-driven attachments.

Mechanical connection

For hung attachments, the attachment and fork carriage must be of the same class.

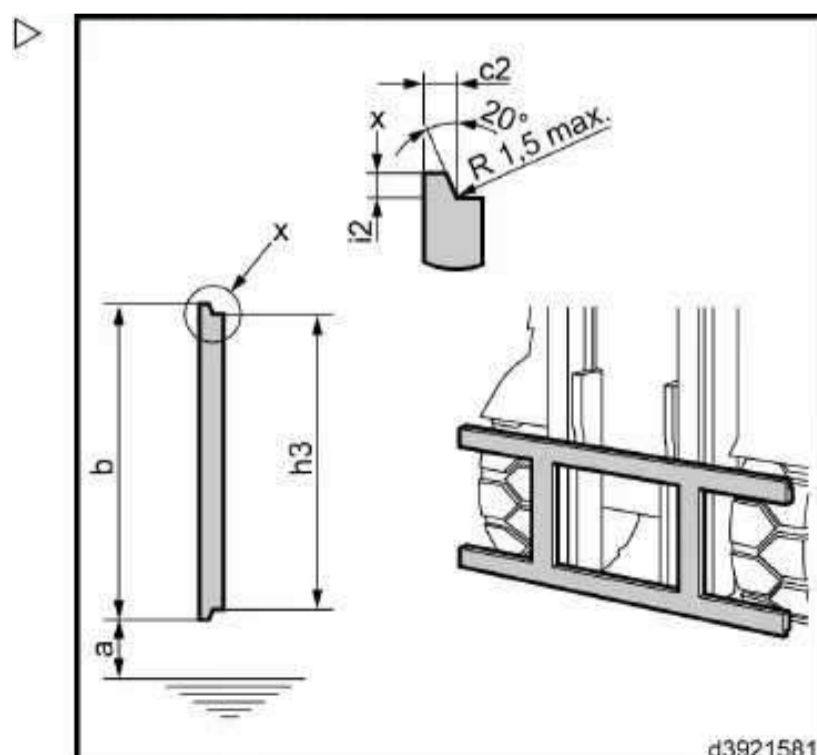

Class As per ISO 2328	Load capacity Truck kg	Load centre of gravity mm	Design	a mm	b mm	c2 mm	i2 mm	h3 mm
1	0 - 999	400 and 600	A	76	331	16	13	305
			B	114				
2	1000 - 2500	500 and 600	A	76	407	16	13	381
			B	152				
3	2501 - 4999	500 and 600	A	76	508	21.5	16	476
			B	203				
4	5000 - 8000	600	A	127	635	25.5	19	597
			B	254				
5	8001 - 10999	600	A	127	728	34	25	678
			B	257				

Integrated attachments are made to match the installed lift mast. When fitting attachments retroactively, the correct attachment and all necessary parts from the industrial truck manufacturer—especially lift mast rollers and chain holders—must be available.

Contact your Service-partner.

Hydraulic connection

⚠ WARNING

Hydraulic system is under pressure. Risk of injury.

Wear protective equipment.

⚠ CAUTION

Damage to the hydraulic system through contamination.

When connecting hydraulic lines, ensure they are clean.

Before connecting hydraulic lines or hydraulic couplings, the hydraulic system must be depressurised.

Without depressurisation:

- Place a collection container underneath.
- Carefully release connection of the hydraulic lines.

2 Safety

Emergency exit with attached rear window

When the pressure is reduced, hydraulic oil escapes.

- Disconnect hydraulic lines.
- Connect hydraulic lines to attachment.

With depressurisation: (special equipment)

- Depressurise the hydraulic lines as described in section "Depressurisation".
- Disconnect hydraulic lines.
- Connect hydraulic lines to attachment.

Additional capacity rating plate

Attachments alter the load capacity and stability of the truck. For each attachment, an additional capacity rating plate must be mounted where the driver can see it that indicates the load capacity of the truck with attachment; see section "Additional capacity rating plate for attachments".

A symbol sticker for the relevant attachment must be affixed behind the actuating lever.

Emergency exit with attached rear window

NOTE

If the truck is equipped with a front or rear window, should the truck experience a malfunction while in a narrow passageway, it is very difficult for the driver to open the side door. In this emergency situation, the driver can leave the truck from the rear window. The driver can use a hammer to break the glass and get out.

Manually tilting the mast and lowering the fork

- Remove the fixed bolt (2) from the fixator (1) mounted on the lower right corner of the additional electronic equipment.
- Remove the hammer (3), and break the window glass

⚠ DANGER

Be careful of scratches!

- Remove all the shards of glass.
- Carefully climb out from the rear window.

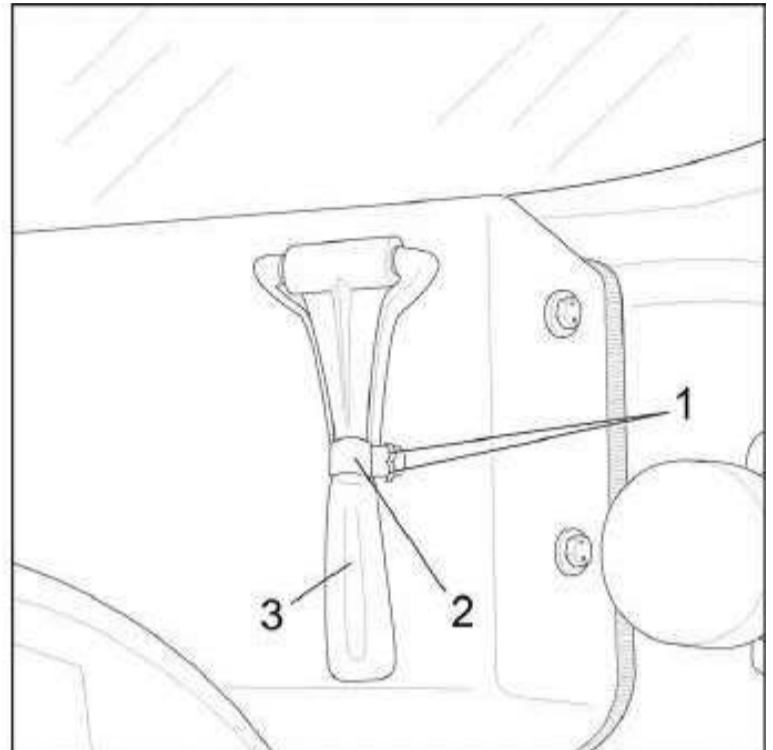

Manually tilting the mast and lowering the fork

Manually tilting the mast

i NOTE

The overhead guard cannot be opened when the mast is tilted backwards. If the truck experiences a malfunction, the mast can be tilted forwards manually.

- If possible, completely lower the fork carriage.

⚠ DANGER

When the mast is tilted backwards, do not stand in the vicinity of the fork.

The mast and fork will tilt forwards after the tilt cylinder has been bypassed.

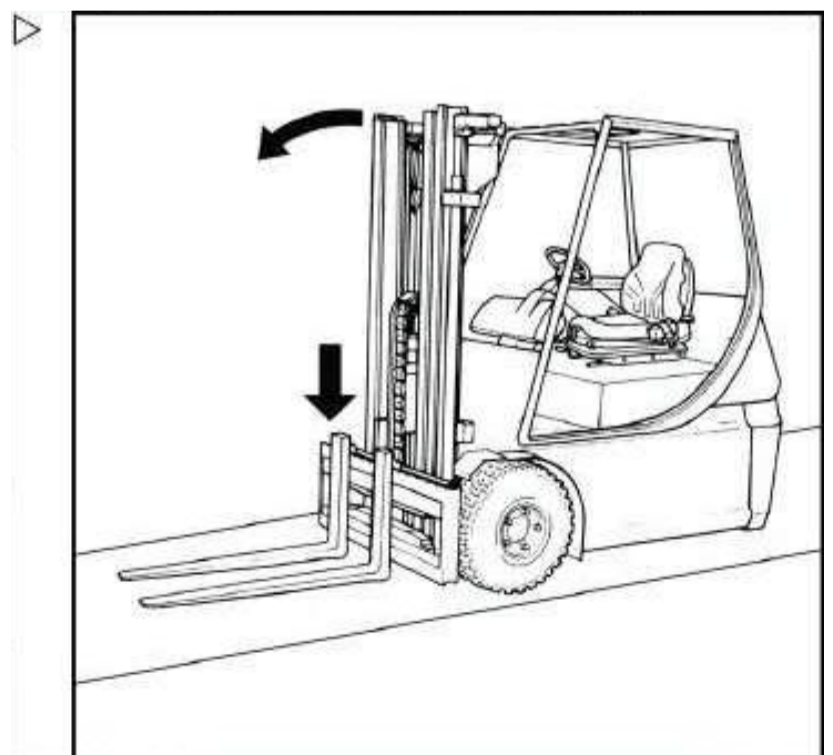

2 Safety

Manually tilting the mast and lowering the fork

- Loosen the overhead guard. Stop when the overhead guard touches the mast. ▷
- Remove the cap. (1).
- Insert the screwdriver through the opening and find the round head screw (2).
- Slowly turn the screwdriver anticlockwise for about 2 revolutions.
- Push the mast forward by hand.
- So that it separates from the overhead guard.
- Tighten the round head screw (2) as much as possible.

NOTE

When finished, immediately turn the round head screw (2) back to its original position, otherwise there will be no way to use the control lever to operate the tilt cylinder.

- Replace the cap (1) in its original position.

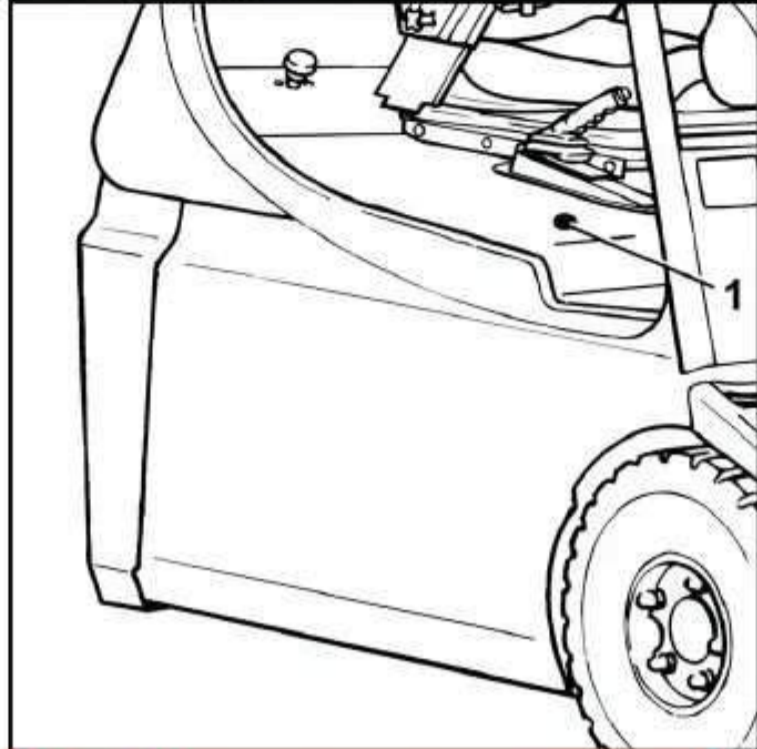

Manually lowering the fork

NOTE

Note If the truck has a malfunction, the fork can be lowered manually.

- Open the overhead guard to the first locking position. ▷

DANGER

Do not stand in the vicinity of the fork when it is being lowered. The lowering of the mast can be stopped at any time by separating the screwdriver from the round head screw (3).

- Use the screwdriver to turn the screw (3) anticlockwise 1 revolution, until the fork is completely lowered.
- Tighten the round head bolts (3) as much as possible by turning in a clockwise direction; otherwise there will be no way to use the control lever to operate the fork.

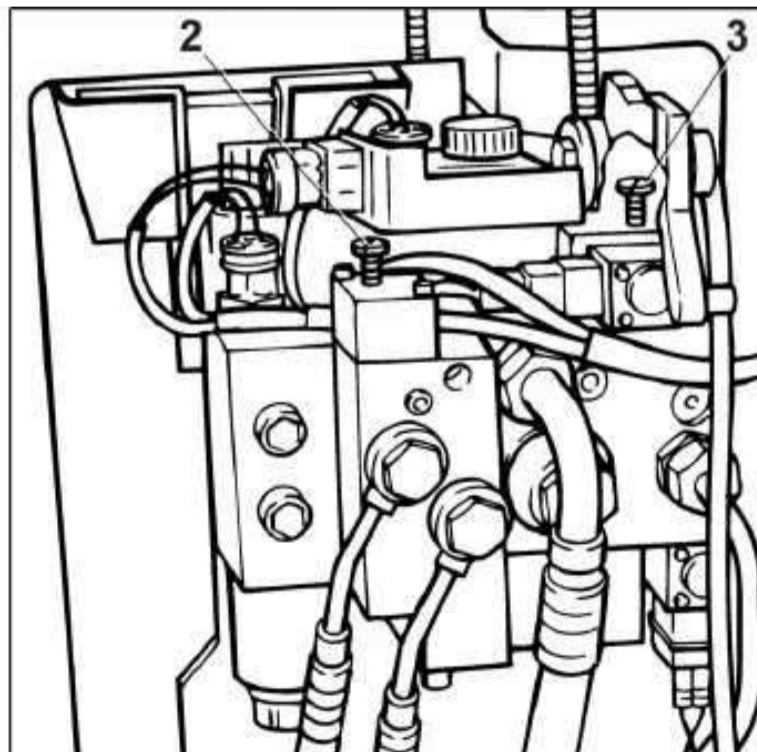

Do not use cables to open the overhead guard by force

Do not use cables to open the overhead guard by force

Do not use cables to open the overhead guard by force

NOTE

Only use when it is not possible to use a cable with a rod (4) to open the overhead guard.

- Lower mast.
- If it is the triple mast equipped with twin hydraulic attachments, the lift mast will prevent lowering.
- Use a suitable tool (hammer handle (1), or crowbar) to push the lever (2).
- When the overhead guard has been loosened, it is held in place only by a catch pin (4).

CAUTION

After loosening the catch pin, the overhead guard will open automatically due to spring force.

- The overhead guard can continue to be opened as usual.

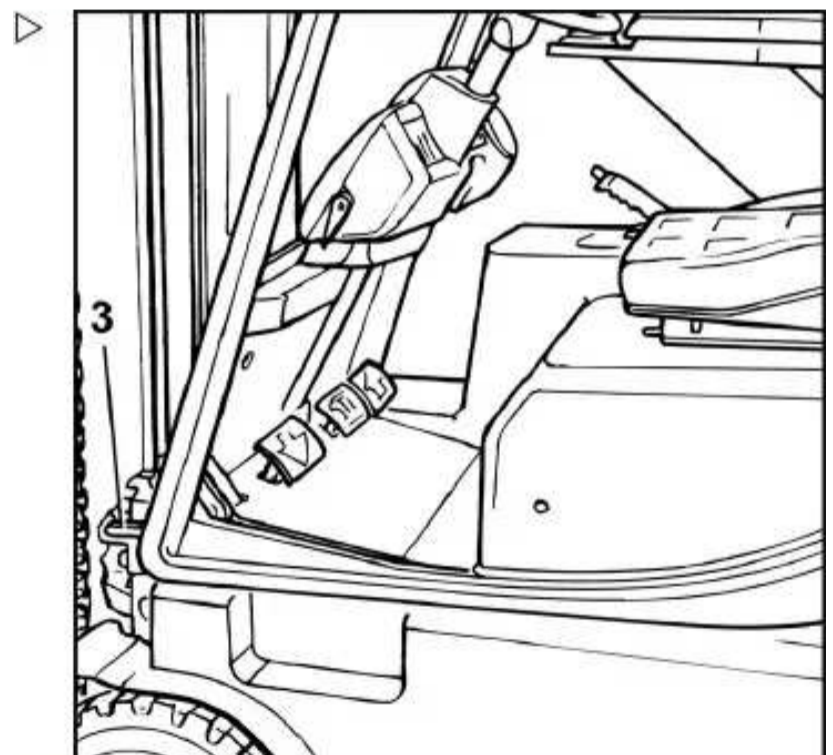
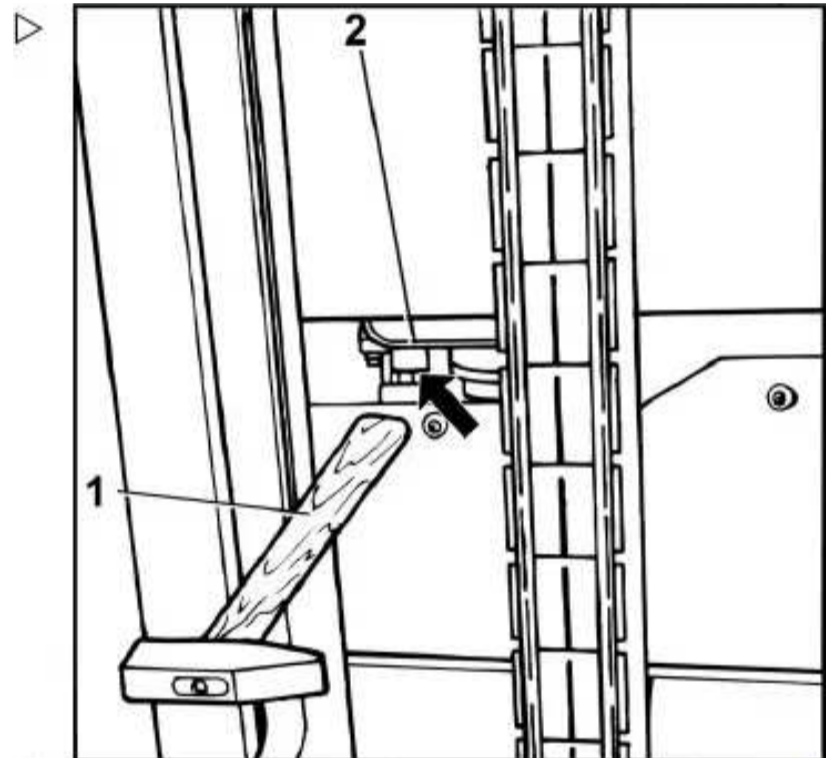

2 Safety

Do not use cables to open the overhead guard by force

Overview of the forklift truck

3 Overview of the forklift truck

Identification plate

Identification plate

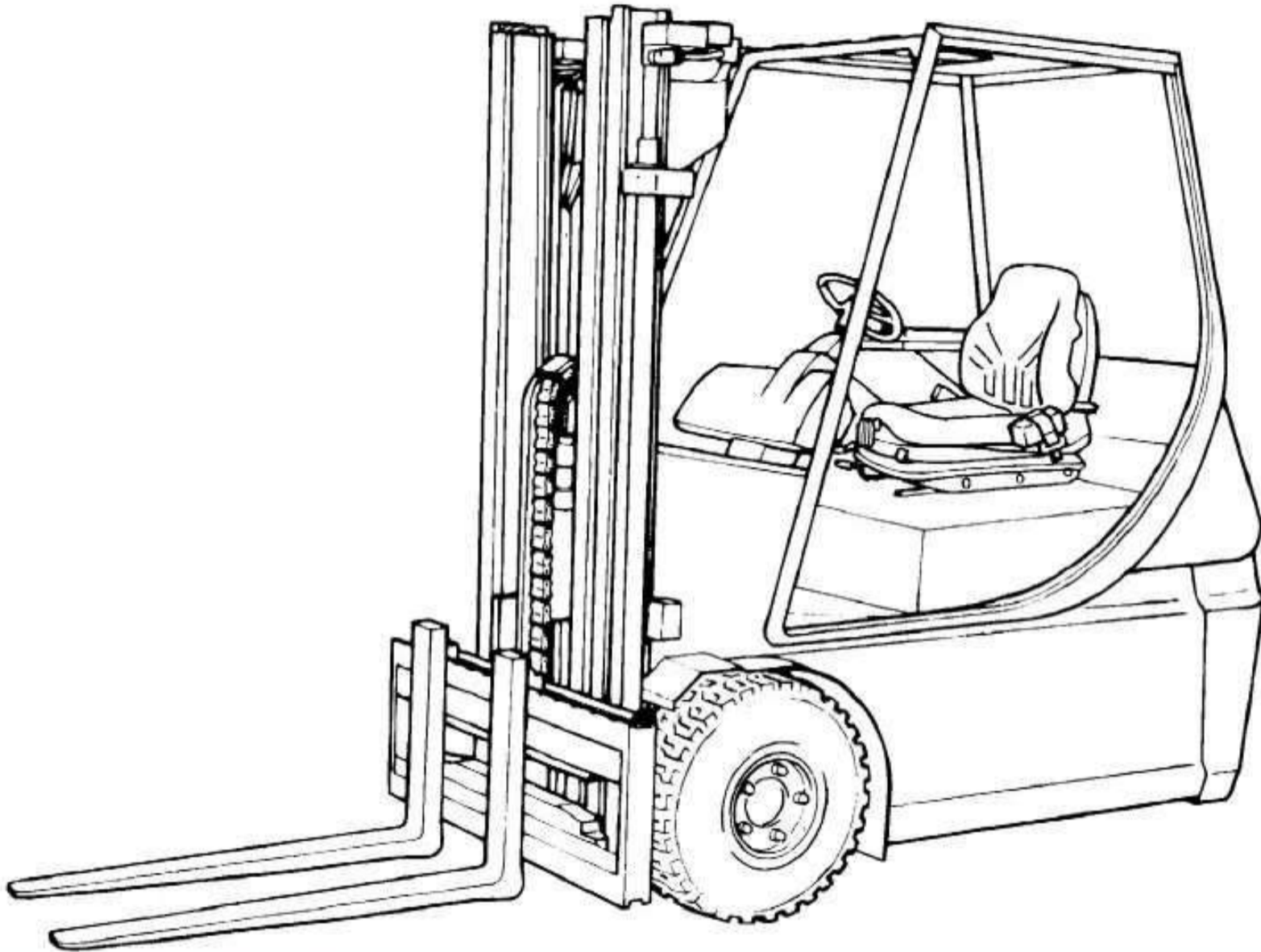

- | | | | |
|----|---|----|---------------------------------|
| 11 | Mast number (stamped) | 14 | Traction motor, left side |
| 12 | Working and power steering hydraulic pump motor nameplate | 15 | Traction motor, right side |
| 13 | Gearbox, left side | 16 | Gearbox, right side |
| | | 17 | Chassis serial number (stamped) |

i NOTE

The CE mark confirms compliance with the EC machinery directive and with all regulations applicable to forklift trucks.

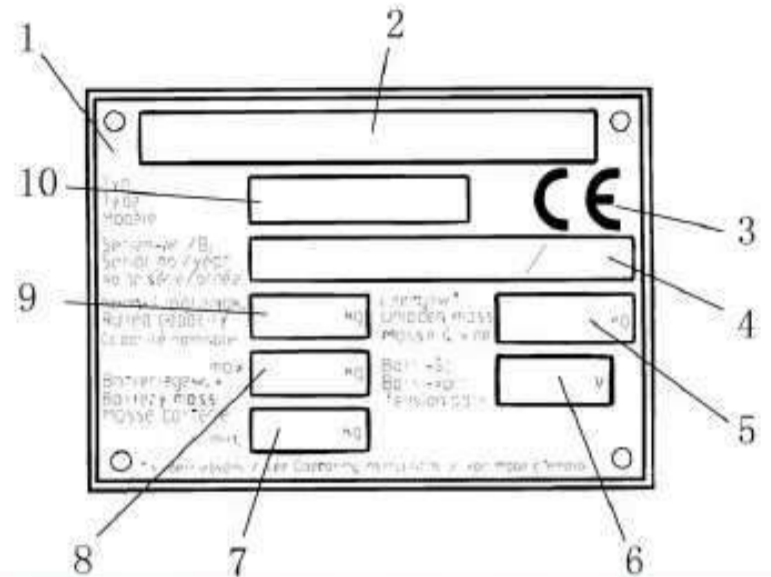

- 1 Identification plates
- 2 Manufacturer
- 3 CE mark (This mark indicates compliance with EC mechanical regulations and all relevant regulations)
- 4 Serial number/year
- 5 Truck weight
- 6 Battery Voltage
- 7 Minimum battery weight
- 8 Maximum battery weight
- 9 Rated load capacity
- 10 Model

3 Overview of the forklift truck

Overview of the forklift truck

Overview of the forklift truck

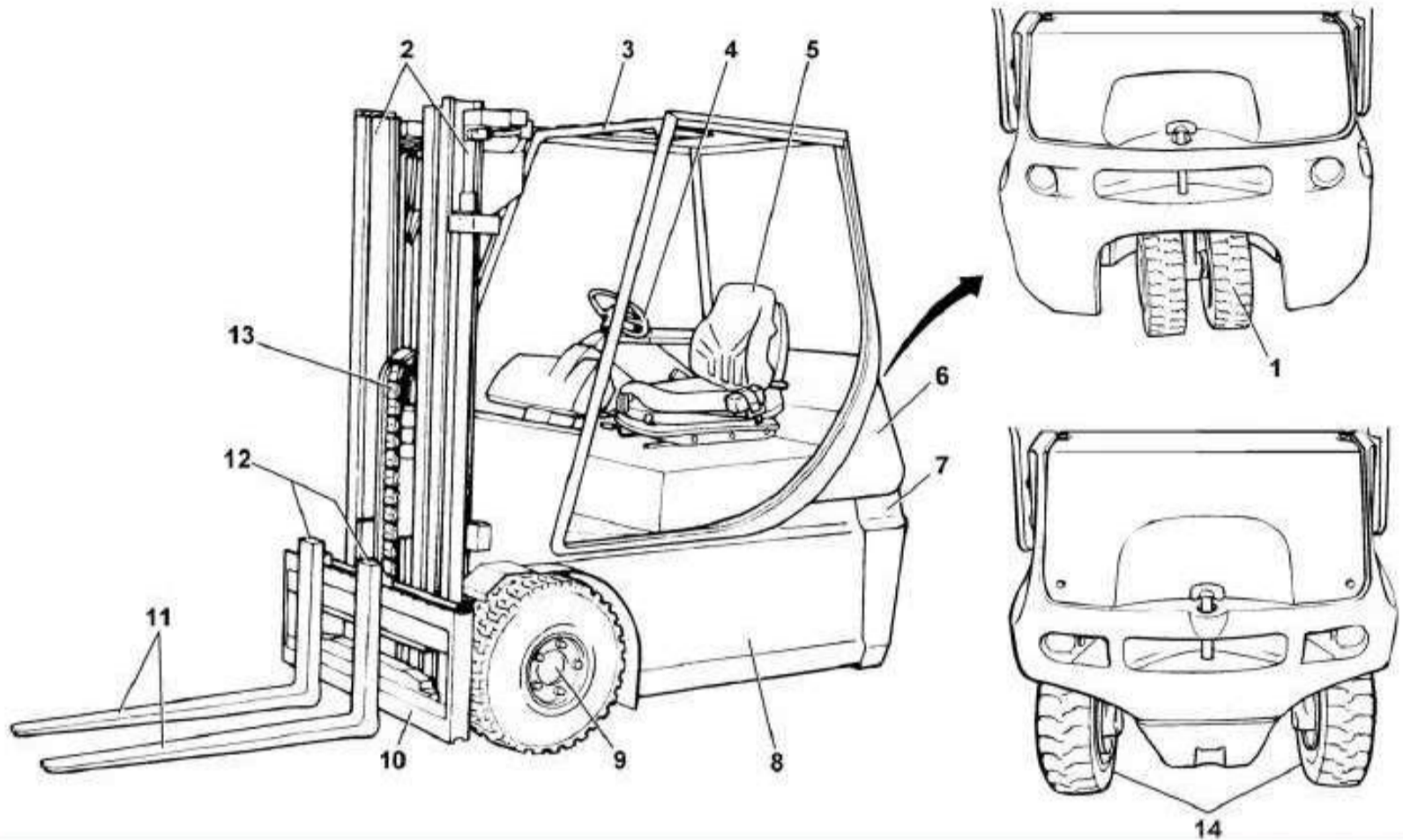

- | | | | |
|---|--------------------------|----|-------------------------------|
| 1 | Compact steering axle | 8 | Chassis, built-in batterypack |
| 2 | Lift cylinder | 9 | Left side gearbox |
| 3 | Overhead guard (lifting) | 10 | Fork carriage |
| 4 | Steering wheel | 11 | Forks |
| 5 | Driver's seat | 12 | Fork rapid release equipment |
| 6 | Electrical system hood | 13 | Lift chain |
| 7 | Ballast weight | 14 | Compound steering axle |

Operating devices

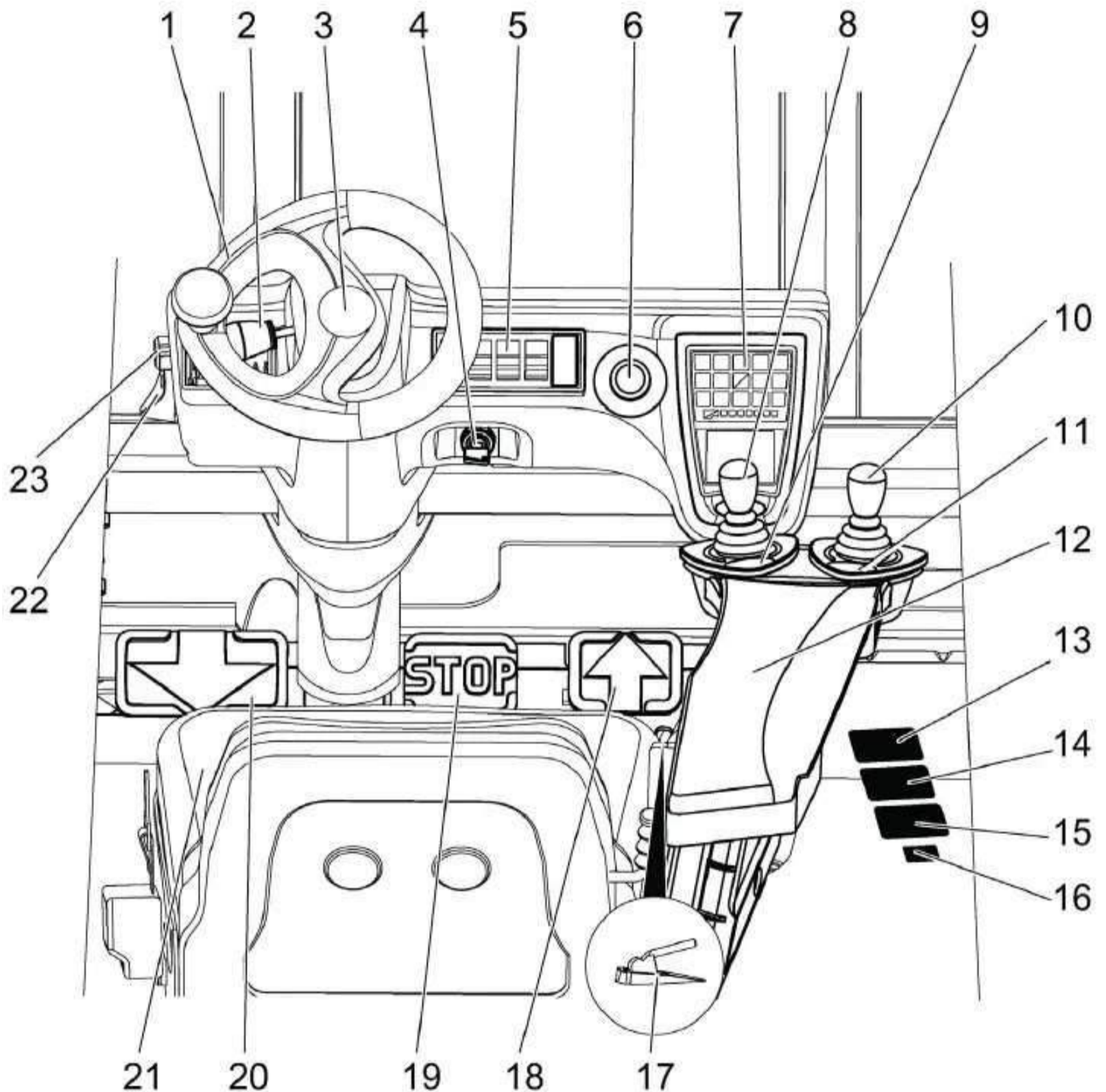

- | | | | |
|----|--|----|---|
| 1 | Steering wheel (hydrostatic power steering) | 12 | Driver armrest |
| 2 | Steering wheel | 13 | Load diagram |
| 3 | Horn signal button | 14 | Prompt label |
| 4 | Electric switch and key | 15 | Load label (attachments)* |
| 5 | Toggle switch for additional functions* | 16 | "No electrical braking" prompt label** |
| 6 | Emergency off switch | 17 | Hand brake level |
| 7 | Instrument panel | 18 | Forward pedal |
| 8 | Working hydraulic control lever (joystick) | 19 | Brake pedal |
| 9 | Working hydraulic control lever operating label | 20 | Reverse pedal |
| 10 | Hydraulic attachments control lever (joystick)* | 21 | Driver's seat with seat position switch |
| 11 | Hydraulic attachments control lever (joystick) operating label | 22 | Overhead guard release lever |
| | | 23 | Diagnostic socket |

3 Overview of the forklift truck

Display unit

Display unit

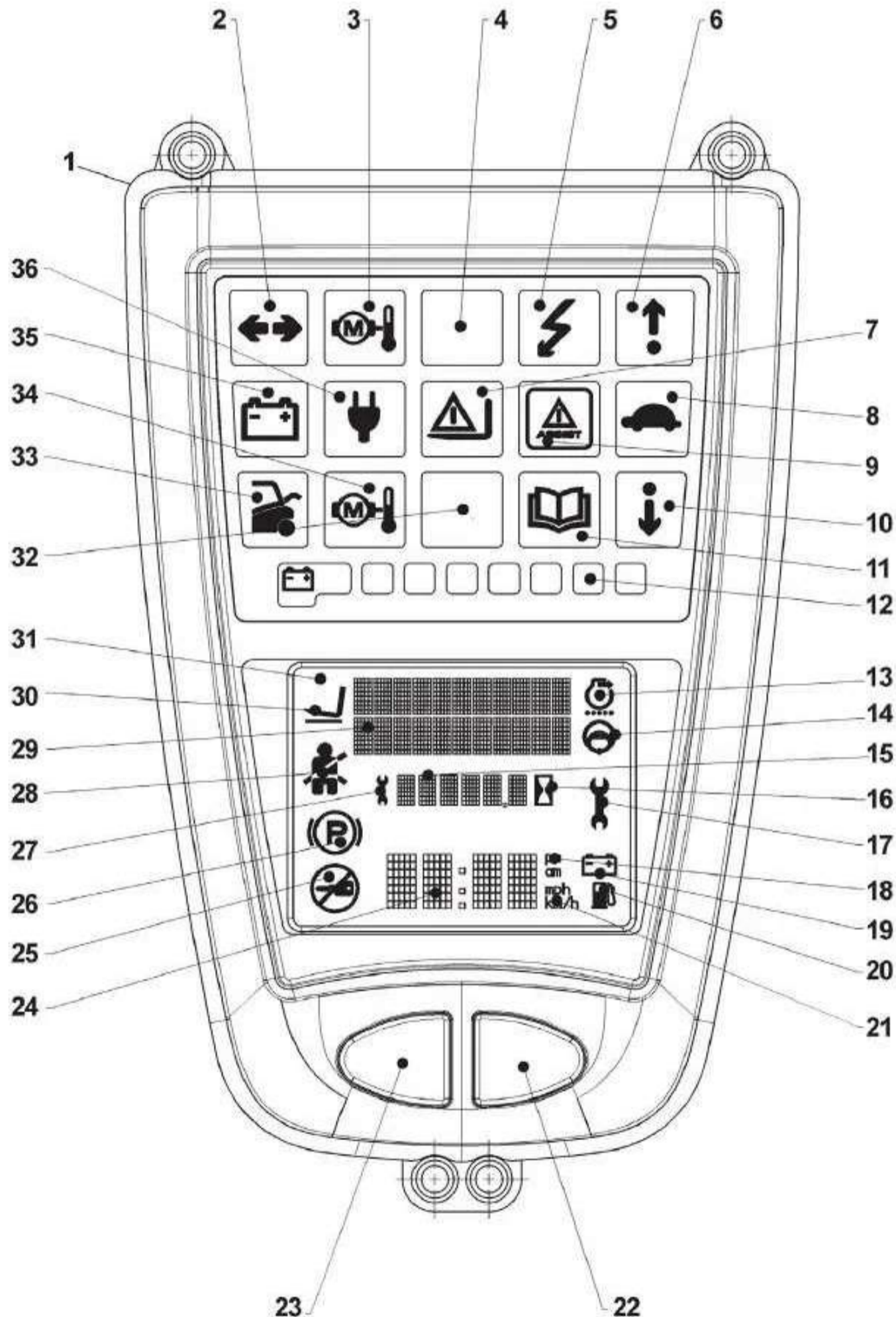

- | | | | |
|---|---|---|--|
| 1 | Display unit | 5 | Error in electrical controller or integrated |
| 2 | Direction indicator light (green) | 6 | battery charger (red) |
| 3 | Engine temperature at upper limit (red) | | Drive direction forwards for single-pedal |
| 4 | Neutral warning light (red) / no function | | trucks (green) |

7	Active lift stop reached (green) Error in lift stop sensor system (red) (special equipment)	22	Function key
8	Speed reduction activated (green)	23	Reset button
9	Lift mast vibration absorption active (yellow) (special equipment)	24	Clock/ remaining travel time / speed display
10	Drive direction backwards for single-pedal trucks (green)	25	Without function
11	Refer to truck documentation (yellow)	26	Parking brake activated
12	Battery discharge indicator (green/red)	27	Operating hours until next service
13	Without function	28	Seat belt not fastened
14	Steering position display active	29	Text field for error code
15	Operating hours display	30	Lift mast positioning activated (special equipment)
16	Hour meter active	31	LCD display with backlight (orange)
17	Service interval exceeded	32	Neutral warning light (yellow)
18	Clock display (am/pm)	33	Rear cover monitoring
19	Display for electric forklift truck remaining travel time active	34	Prewarning: engine temperature increasing (yellow)
20	Without function	35	Battery charging via integrated charger finished — green (special equipment)
21	Speed display (km/h / mph)	36	Integrated charger in charging mode — yellow (special equipment)

The indicator unit (1) is located to the right side of the overhead guard, above the driver. Fixed within the driver's field of vision, it provides centralised information regarding all vehicle functions. After opening the key switch, the display unit performs a self-test. During self-testing, all indicator lights and LCD indicators are activated.

(2) Direction indicator light (green)

The green direction indicator light on forklift trucks with lighting equipment is used to check whether the direction indicator light has already been activated. It lights up when the direction indicator light switch on the turning wheels is started.

(3) Indicator light (red), motor temperature at upper limit

When the motor or power module reaches its acceptable temperature limit, the red indicator light lights up. An error code is displayed in the text display area, which can be used to determine which components have been affected.

When the maximum permissible temperature limit is reached, the warning buzzer integrated

in the display unit is also activated.

(4) Neutral warning light (red), no function

The red indicator light provides optional information regarding necessary maintenance tasks. This function can be programmed via truck diagnostics. Please contact your authorised dealer.

(5) Indicator light (red), error in the electrical control or integrated charger

Lights up when a malfunction occurs during electrical controller or battery charger operation. An error code is simultaneously displayed in the text area (29).

(6) Indicator light (green), forward drive direction in single-pedal trucks

Lights up when the drive direction forwards is selected using the drive direction switch for single-pedal trucks.

(7) Activated lift stop (red/green)

If the green indicator light lights up, it shows that the activated lift stop has already been reached. If the red indicator light lights up, it shows that an error has occurred in the lift stop sensor system.

(8) Indicator light (green), speed reduction activated

The green indicator light signals that the speed has been reduced via an optional switch.

3 Overview of the forklift truck

Display unit

(9) Indicator light (yellow), lift mast vibration absorption

The yellow indicator light illuminates as soon as vibration absorption is active for the lift mast.

(10) Indicator light (green), reverse drive direction in single-pedal trucks

With single-pedal trucks, the green indicator light signals that backwards direction has been selected using the drive direction selector switch.

(11) Indicator light (yellow), observe truck documentation

When the yellow indicator light lights up, it may show that there is an operational error or malfunction. When this indicator light lights up, there will usually be an error code displayed in the text display area (29) at the same time.

The following operating errors will activate the lamp:

- Seat switch and/or FDE unit not activated and accelerator pedal actuated
- Battery charger connected to system voltage and accelerator pedal actuated
- Tilt angle sensor alignment process active
- Alignment of the sensor system for a new truck control unit not yet taken place

Please contact your authorised dealer.

(12) Battery discharge indicator (LED bar display)

Displays the current charging status of the battery. The discharge status of the battery is displayed on the display unit via the LED bar display. 7 green LEDs go out one by one as the battery discharges. Once the battery discharge reaches 80%, the red LED with the rechargeable battery symbol lights up. As the rechargeable battery continues to discharge (remaining capacity of the battery <20%), the red LED flashes.

(13) Particle filter symbol display active without function

(14) Steering position display symbol display activated

The second line of the text display area displays the steering angle. If the steering angle display is turned on, the symbol on the indicator unit (14) lights up.

(15) Operating hours display

Indicates the truck's operating hours. This display is evidence of the truck's operating time and of the inspection and maintenance work to be performed.

NOTE

If replacing a malfunctioning indicator unit, the operating hours up until that moment must be recorded. The data should be attached to the embossed strip beside the indicator unit. This should also be done later when replacing the new indicator unit. Please contact your authorised dealer.

(16) Symbol for hour meter active

Hour meter symbol (16) flashes and the operating hours are counted when the truck is switched on and the seat switch is activated.

(17) Symbol for service interval exceeded

(18) Clock display symbol (am/pm)

(19) Display for electric forklift truck remaining travel time active

(20) Without function

(21) Speed display (km/h / mph)

(22) Function key

To adjust the time, to switch off the warning sound and other functions depending on the version.

(23) Reset button

Assignment depending on version

(24) Clock / remaining travel time / speed display

24-hour clock display.

 NOTE

It is possible to change to 12-hour format using diagnostic software. Please contact your authorised dealer.

(25) Without function**(26) Symbol for parking brake activated**

The parking brake symbol is switched on as soon as the parking brake is activated.

(27) Symbol for operating hours service

When the key switch is switched on, the display shows the operating hours until the next service for approx. 5 seconds. The symbol lights up simultaneously.

Adjustment and reset of the intervals can be performed only with the diagnostic software provided for this purpose.

Please contact your authorised dealer.

(28) Seat belt not fastened**(29) First line in text field contains error code for lift height display**

Second line in text field contains error code for steering position display

(30) Lift mast position identification symbol (special equipment)

Lights up when the "lift mast position identification function is activated."

(31) LCD display**(32) Depressurisation of working hydraulics (yellow) / without function**

The neutral yellow indicator light flashes and provides information on whether all conditions for depressurisation of the working hydraulics have been met.

(33) Rear cover (yellow) open

If the truck's rear cover is open, the yellow indicator light lights up. For trucks with an integrated charger, this is monitored to prevent the truck from being driven if the charging cable is still connected to the truck.

(34) Indicator light (yellow), prewarning for increased motor temperature

Lights up when the temperature of a motor is raised.

(35) Indicator light (green), battery charging via integrated charger finished.

The green indicator light is activated by the integrated charger when charging of the rechargeable battery is complete. The indicator light flashes during charging. The indicator light is directly activated by the integrated charger.

(36) Indicator light (yellow), charging via integrated charger (special equipment)

The yellow indicator light illuminates if the truck battery is charged.

The yellow indicator light is activated by the integrated charger during charging of the truck battery. The indicator light flashes during charging.



3 Overview of the forklift truck

Display unit

4

Operation

Pre-use daily checks and maintenance

Pre-use daily checks and maintenance

Pre-shift checks

	Carried out	
	✓	✗
Chassis, bodywork and fittings		
Check the condition and function of the driver's seat and seat belt.		
Chassis frame		
Checking the tyres		
Check brake system and parking brake.		
Electrics/electronics		
Check the charging state of the battery.		
Check electrical system (e.g. lighting, horn, lift functions).		
Check condition of anti-static belt.		
Hydraulics		
Check the oil level in the oil tank of the working and steering hydraulic systems.		
Check truck for leak tightness (visual inspection).		
Subsequent tasks		
Carry out functional test and test drive.		

Opening the overhead guard

Opening the overhead guard

 NOTE

Do not open the door of the driver's cab when the overhead guard is lifted backwards (position 1 or 2), otherwise damage may be caused to the gas spring installation and injury to the driver.

The first lock position: maintenance position

NOTE

The overhead guard cannot be opened when the lift mast is tilted backwards.

- Lower the fork carriage.
- Tilt the lift mast forwards slightly. The truck must be stationary on the ground.
- Pull the hand brake(3).
- Press the emergency off switch(4).

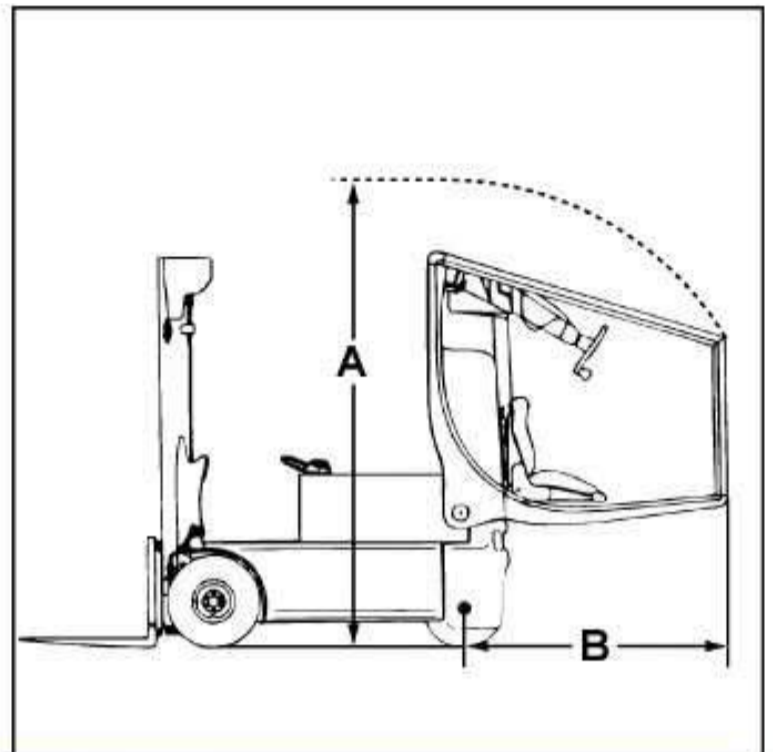

- Stand on the left side of the forklift truck and release the overhead guard.



NOTE

In order to make enough space when lifting the overhead guard backwards, ensure that A is a minimum of 2200 mm and B is a minimum of 1500 mm.

- The lock handle(2) should be pulled back as far as possible.

When the overhead guard has been released, it is only supported by the lock handle(1).

CAUTION

After releasing the lock handle(2) support the spring assembly will automatically open the overhead guard.

- Push the overhead guard down in the direction of the arrow(5) so that there is no longer any force exerted on the lock handle(1).
- Pull up the lock handle(1) to release the overhead guard. The overhead guard will pop up.
- Manually pull the overhead guard into the first lock position, and then release it.
- The overhead guard will be automatically locked in the first lock position by the lock rod(6).

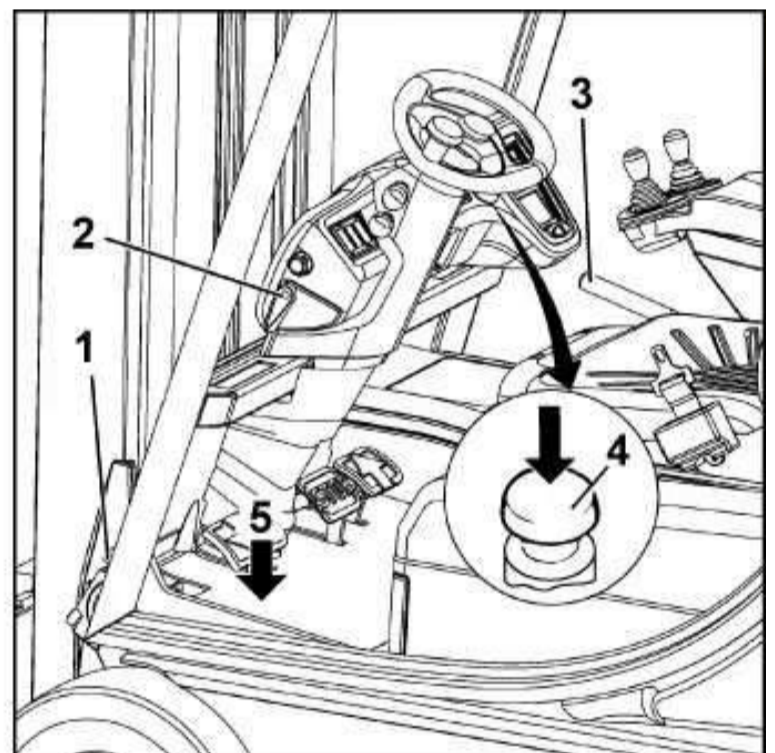

Pre-use daily checks and maintenance

⚠ CAUTION

For an overhead guard with a driver's cab, a maximum of one door only may be removed from the driver's cab.

If both doors are removed, the excessively high spring force will make it impossible to close the overhead guard.

▶ **The second lock position: when replacing the battery**

i NOTE

The overhead guard cannot be opened when the lift mast is tilted backwards.

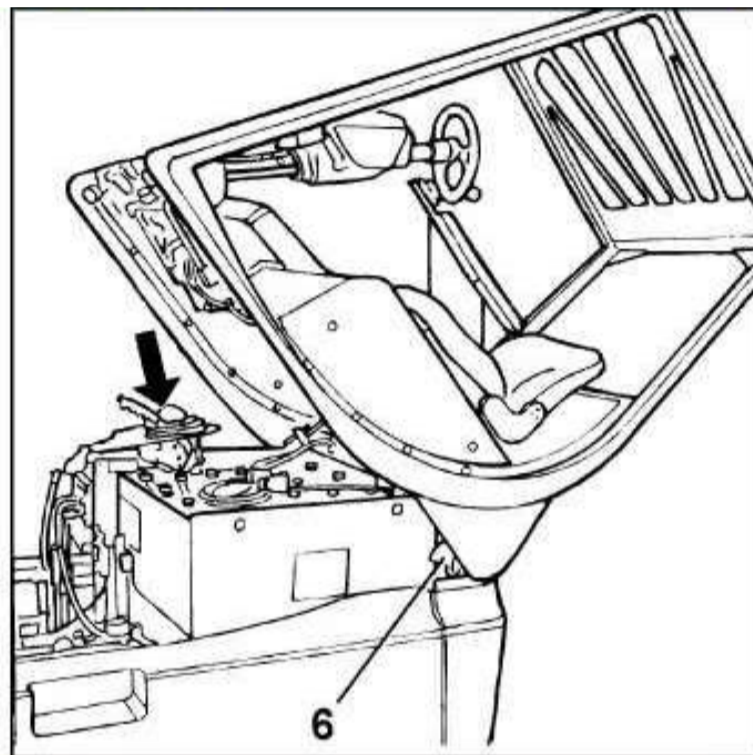

- ▶ Stand on the left side of the forklift truck and release the overhead guard.
- ▶ Hold the overhead guard handle* or overhead guard rear support and lift the overhead guard back as far as possible into the second lock position(6).

* Optional part

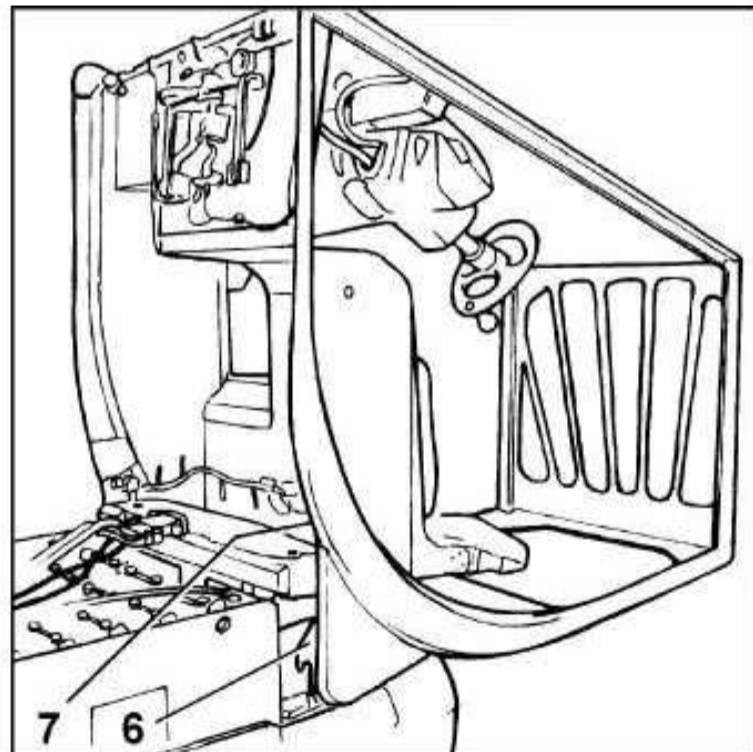

Close the overhead guard

- Stand on the left side of the truck.
- Hold the overhead guard handle* or overhead guard rear support and push the overhead guard in the direction of the mechanical lock release position(6).
- Lift the handle(6) until the second lock position latch releases.

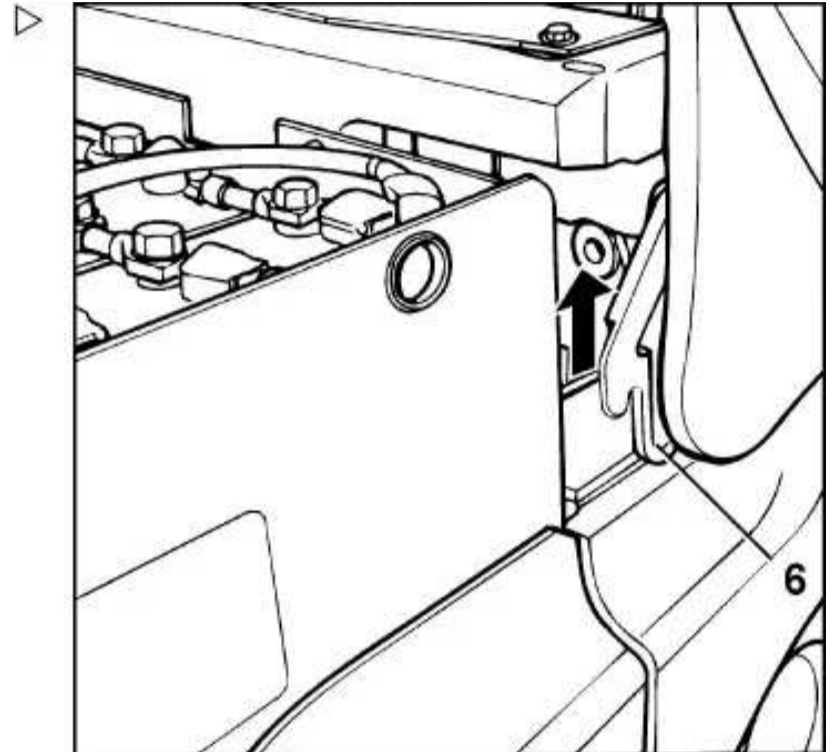

- Push the overhead guard forwards into the first lock position.

* Optional part

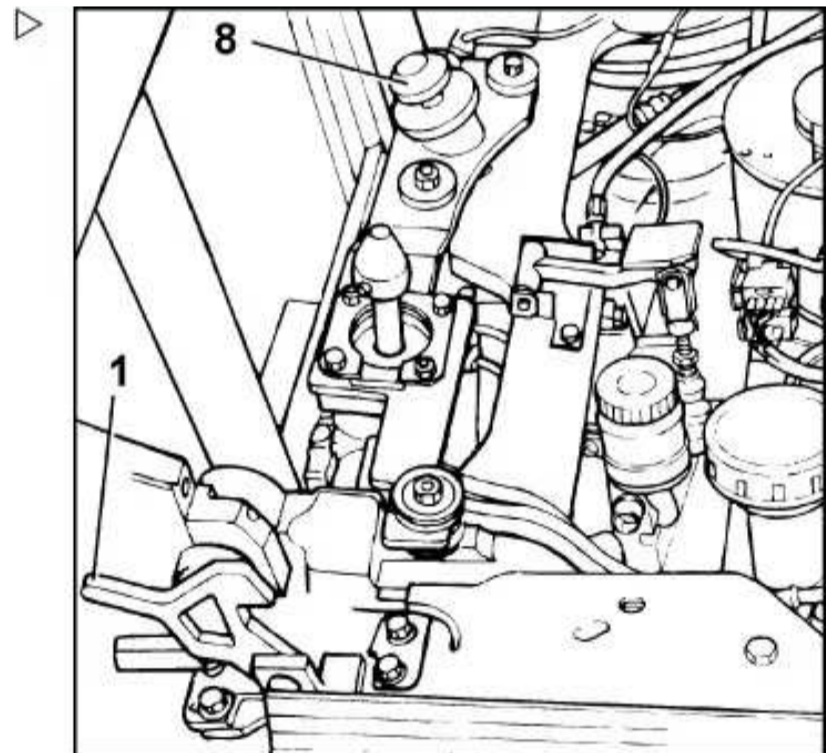

4 Operation

Pre-use daily checks and maintenance

Checking the battery level

Checking the battery level

- Pull the hand brake (3).
- Press the emergency off switch against the spring (4). Press the switch as far as it will go.
- Insert the electric switch key (1) and turn clockwise.
- Check the power level shown on the dashboard (2) discharge indicator (5).

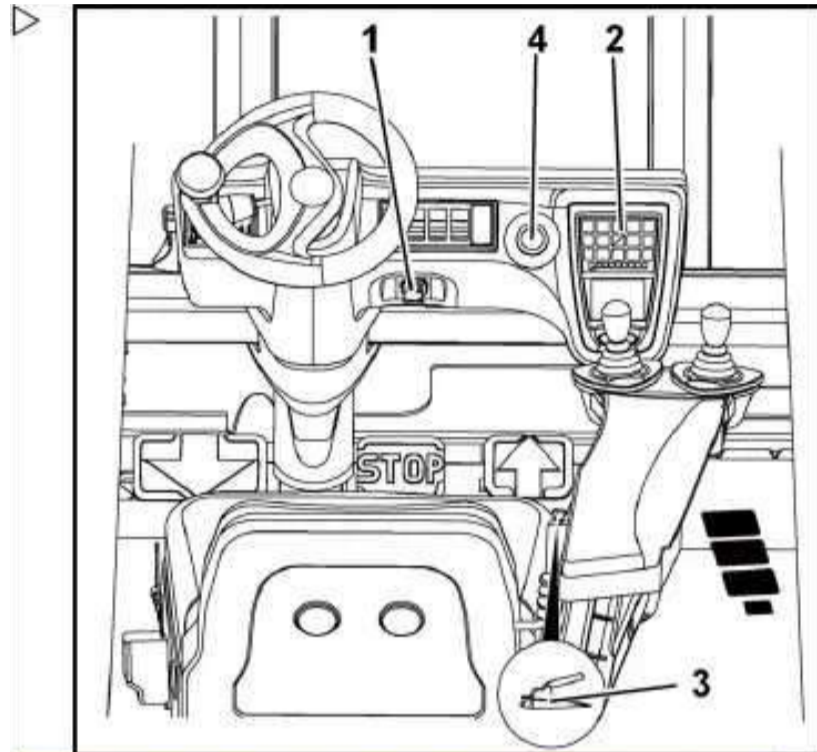

Battery charging

NOTE

Check that the specific gravity of the electrolytes is at least 1.14. Charge and maintain the battery in accordance with instructions from the manufacturer. If there are no instructions, please contact your maintenance agent. Optional battery chargers must also be operated according to instructions. If you already have a battery charger, please follow the instructions.

CAUTION

No metal objects should be placed on the battery. Be careful of short-circuiting the battery! The battery should be filled up with distilled water after charging.

CAUTION

The charging current for the battery must not exceed 160 amperes.

If you are using a charger with a high charging current, please contact your Linde dealer.

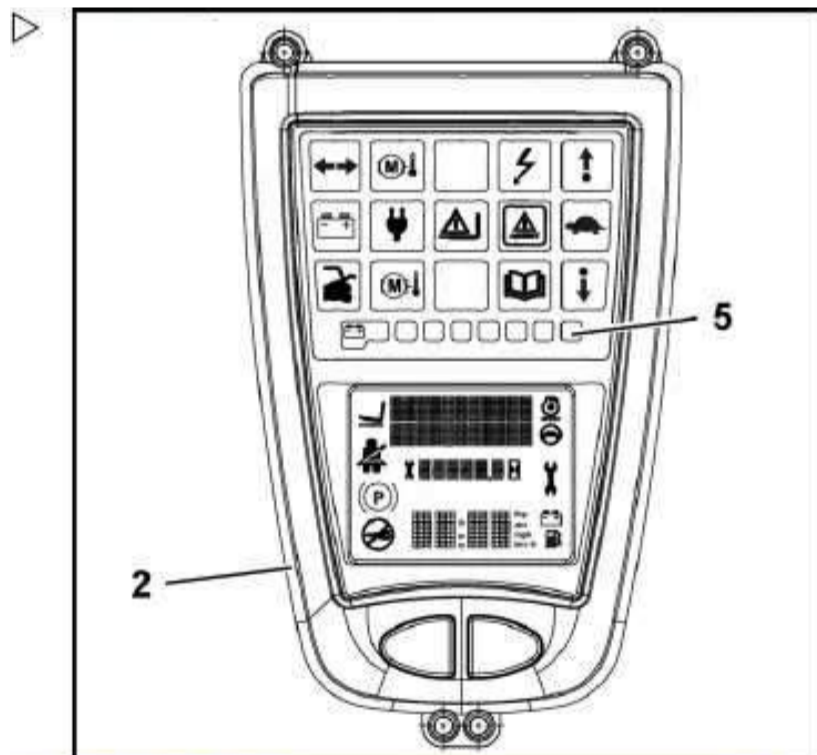

Connecting the battery to an external charger

- Lower the fork.
- Tilt the lift mast forwards slightly. The truck must be stationary on the ground.
- Pull the hand brake (1).
- Press the emergency off switch (2).
- Lift the overhead guard (3) backwards into either the first or second lock position.
- The leading edge of the overhead guard must be raised at least 300mm.
- Disconnect the battery male connector (5) from the battery female connector (4).

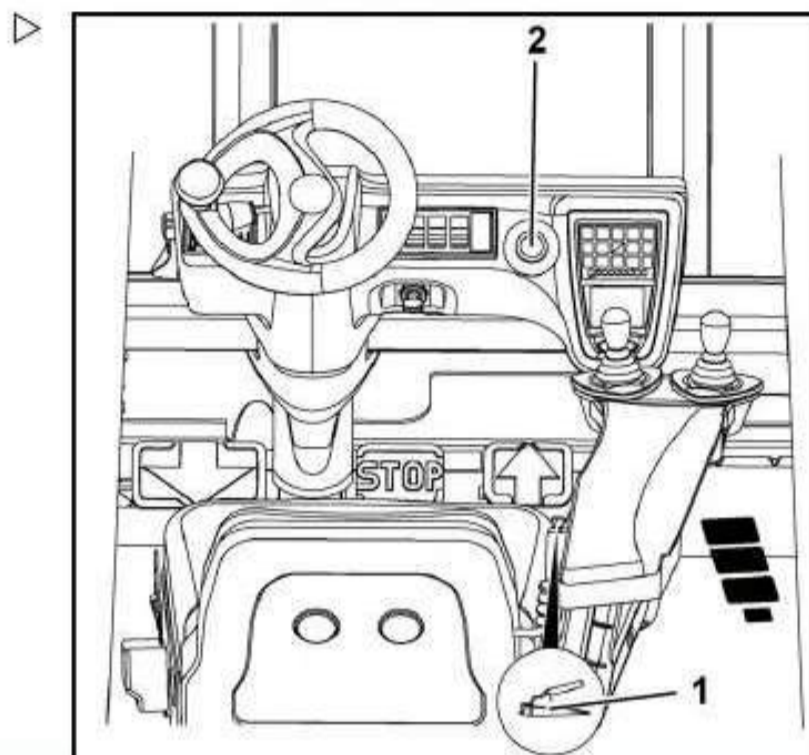

- Plug the battery plug into the battery socket
- Switch on the charger.

Recharge the battery in time. Do not keep the battery fully discharged. This rule also applies to partly discharged batteries.

Battery: Checking the battery condition, electrolyte level and specific gravity

- Inspect battery for cracks, raised plates and electrolyte leaks.
- Unscrew the battery cover and check the electrolyte level.

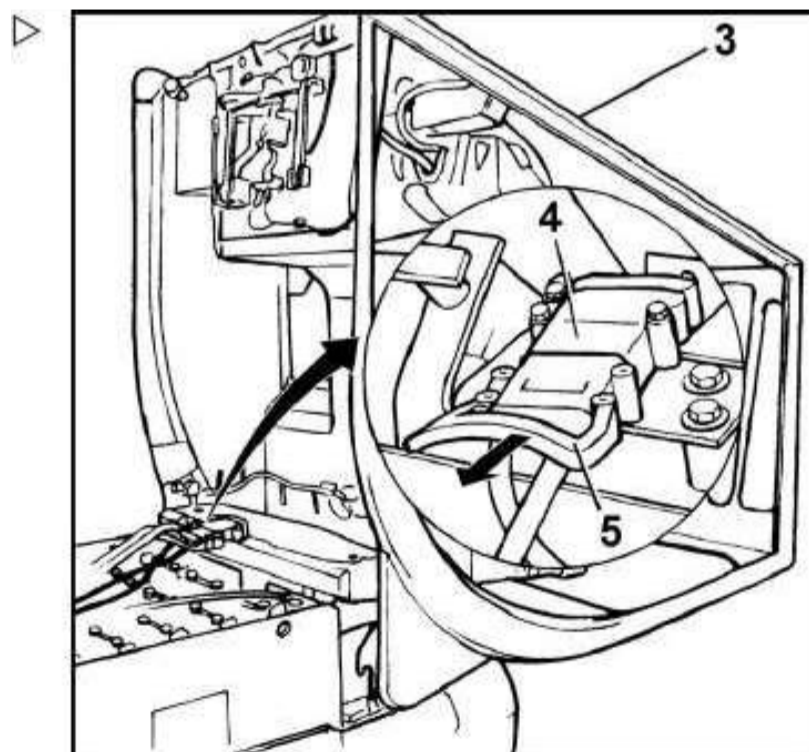

4 Operation

Pre-use daily checks and maintenance

- If the battery has an inspection tube, then the electrolyte level should be at the base of the tube. If there is no inspection pipe, then the electrolyte level should be 10-15 mm higher than the plate.
- If the electrolyte level is excessively low, it can only be filled up with distilled water.
- Remove any sediment from the electrodes and lubricate with non-acidic lubricating grease.
- Retighten the electrode holder.
- Use a hydrometer to check the electrolytes. The specific gravity should be between 1.24-1.28.

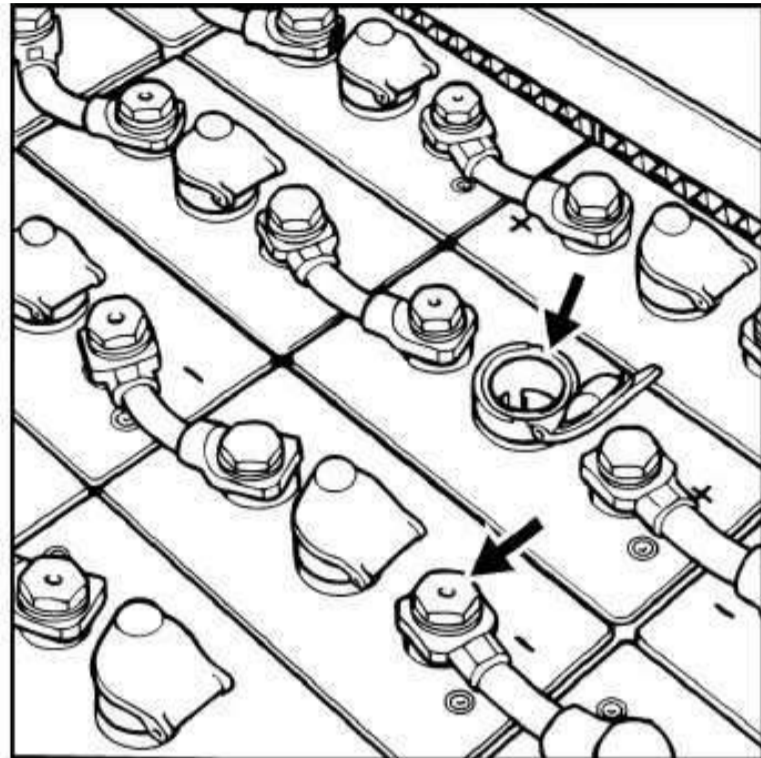

⚠ WARNING

Deep discharge (more than 20% of the battery rated capacity) will cause the battery life to shorten.

Battery change

Battery change

When replacing the battery there should be an interval of at least 6 minutes between removing and reinstalling the battery. Otherwise the discharge indicator will display incorrect data and the working hydraulic equipment will be slower.

⚠ CAUTION

The size and weight of the replacement battery must be the same as the original battery. Extra weight should be added to compensate if the battery weight is insufficient.

The battery must be secured so that it does not slide. Please contact your Linde dealer if necessary.

- Insert the electric switch key (1) and turn clockwise.
- Tilt the lift mast forwards slightly. The truck must be stationary on the ground.

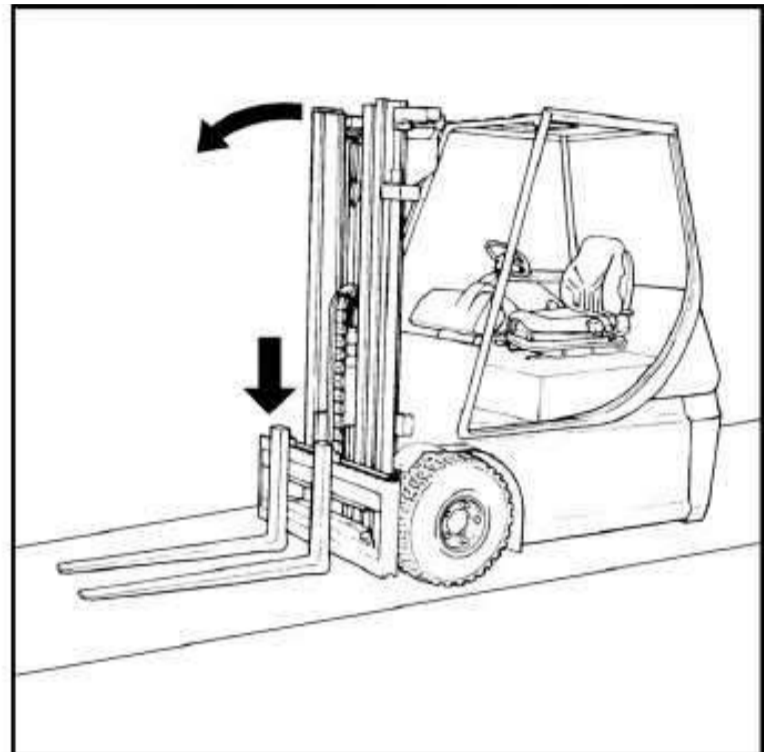

- Pull the hand brake.
- Press the emergency off switch.
- Lift the overhead guard (1) into the second lock position.

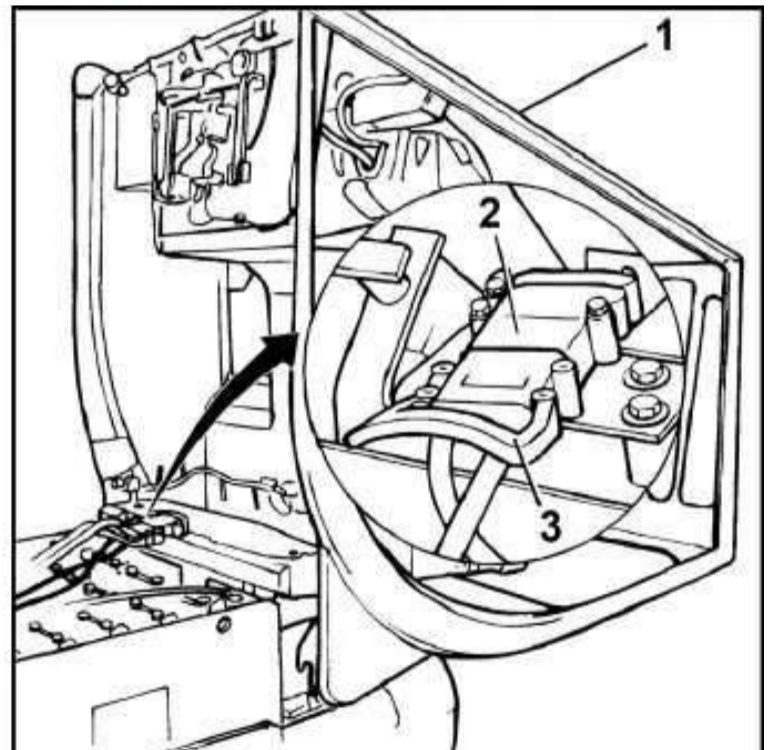

4 Operation

Pre-use daily checks and maintenance

Using a hoist to lift the battery

- Use a hoist and lifting hook with enough lift capacity (refer to the technical data for battery weight).
- Disconnect the battery male connector (3) from the battery female connector (2).
- Pull out the lock pin (4) and retain. Lift the hand brake and control assembly (5) forwards.
- Release the lock pin.
- Place the hoist equipped with a sling below the battery.
- Attach the lifting hook to the battery.
- Place the battery to one side after lifting it away from the chassis.

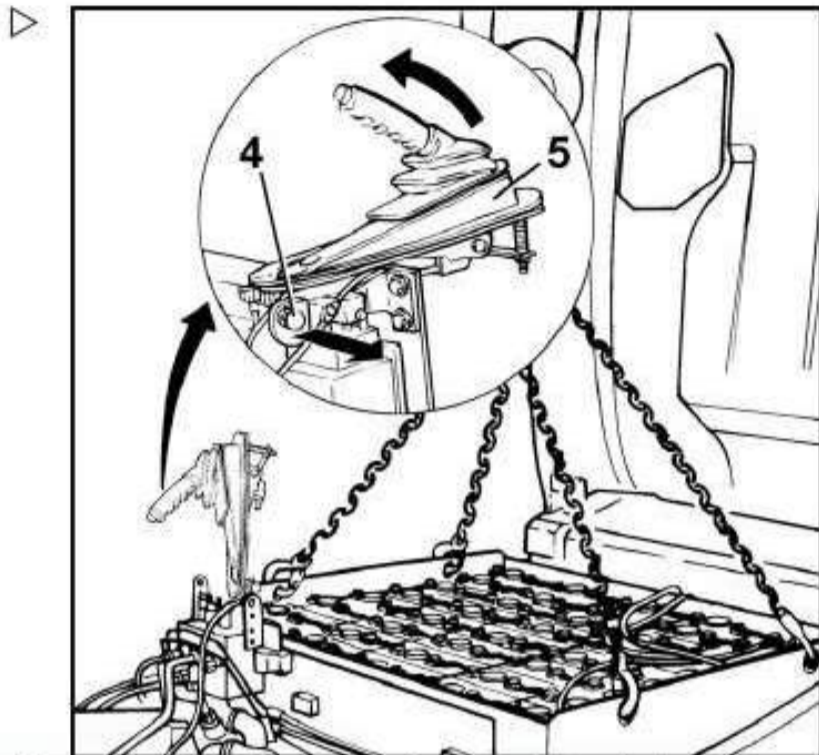

Pre-use daily checks and maintenance

Check the brake fluid level

ENVIRONMENT NOTE

Relevant safety regulations should be followed when handling the brake fluid.

- Lower the fork.
- Tilt the lift mast forwards slightly. The truck must be stationary on the ground.
- Pull the hand brake.
- Press the emergency off switch.
- Lift the overhead guard backwards into the first lock position.

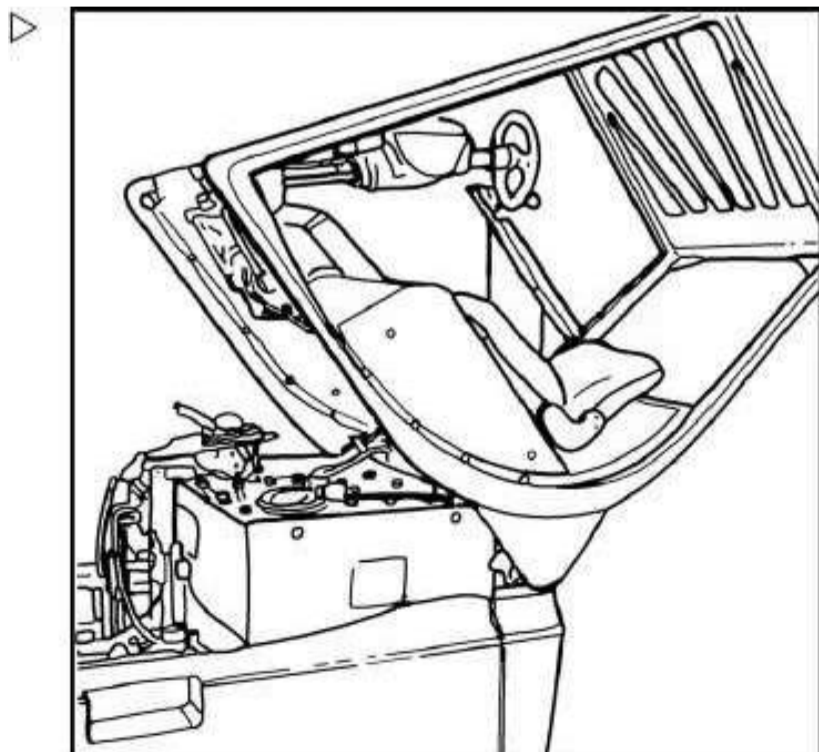

- The brake fluid level must be between the highest and lowest marks on the brake fluid dipstick(4).
- If required, remove the dipstick cap (1) and fill the brake fluid up to the highest marking(2).

⚠ CAUTION

The brake fluid level must be higher than the lowest marking(3), or the brakes will lose their effectiveness.

- Close the overhead guard.

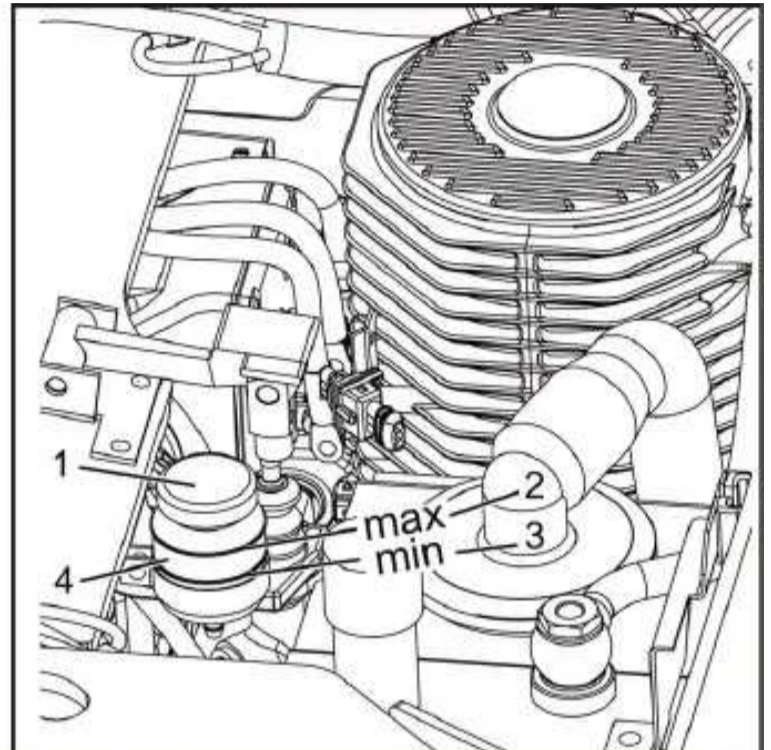

Adjusting the driver's seat

Adjusting the driver's seat

- Pull the handle (1) to horizontally adjust the driver's seat.
- Slide the driver's seat to find the best operating position relative to the steering wheel, the accelerator and braking pedals, and the joystick.
- Return the handle to its place.
- The position of the backrest can be adjusted by lifting the handle (3) upwards.
- Move the backrest forwards and backwards until the driver finds the best sitting position.
- Release the handle (3).

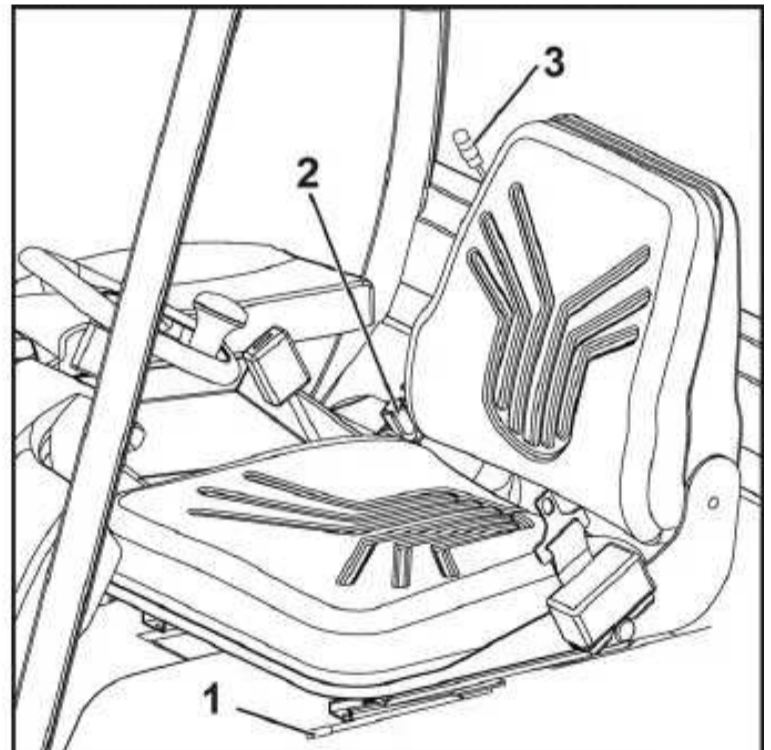

i NOTE

Remaining in a sitting position for long periods of time puts a great amount of pressure on the spine. Make sure to reduce the pressure by bending forwards frequently.

4 Operation

Pre-use daily checks and maintenance

Adjusting the driver's armrest

NOTE

After releasing the clamp screw (1), the armrest will be moved forwards automatically by spring force.

- Sit on the driver's seat and release the clamp screw (1).
- Pull the armrest down against the spring (3) until the most comfortable armrest position is found.
- Lock the clamp screw (1).
- After releasing the clamp screw (2) and slide the armrest (3) forwards or backwards until you can operate the control lever with ease (4).

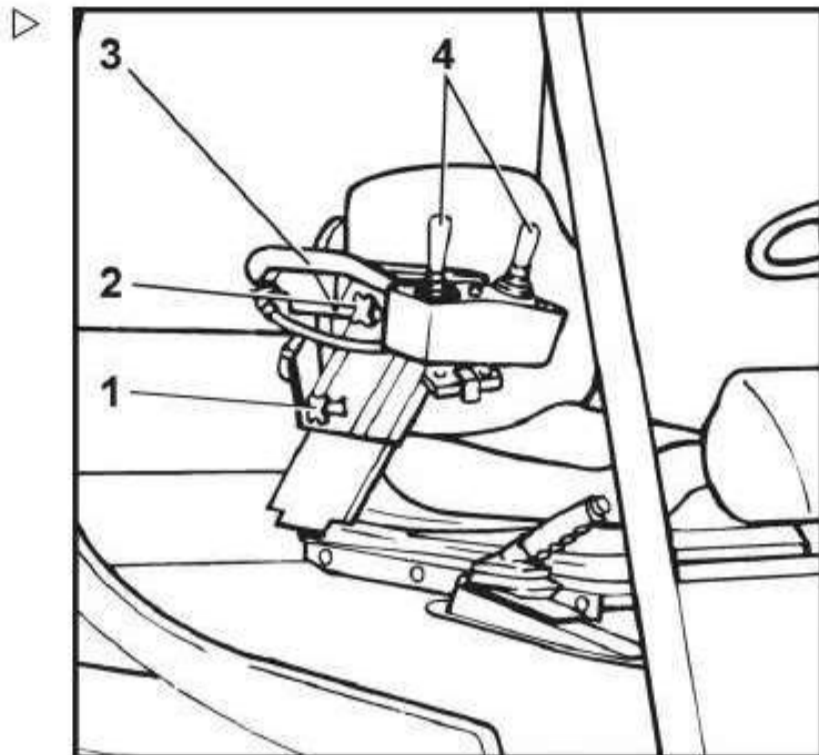

Fastening the seat belt

DANGER

The seat belt should be fastened when using the forklift truck! The seat belt can only be used by one person. For the driver's cab to completely comply with driver safety systems, the vehicle doors (rigid or folding) must be shut tightly when the truck is in operation. We recommend that a seat belt be added to the driver's seat. The seat belt must be fastened when operating the truck with the doors open or when the doors have been removed.

PVC (polyvinyl chloride) vehicle doors are not included in the driver safety system.

- Slowly pull the seat belt (3) out from the seat belt retractor on the left.
- Position the seat belt over the groin area and not the abdomen.
- Insert the buckle (2) into the seat belt socket (5).
- Press the button (4) to adjust the tightness of the seat belt.
- Check the tightness of the safety belt. The safety belt should be just tight enough to secure the body.

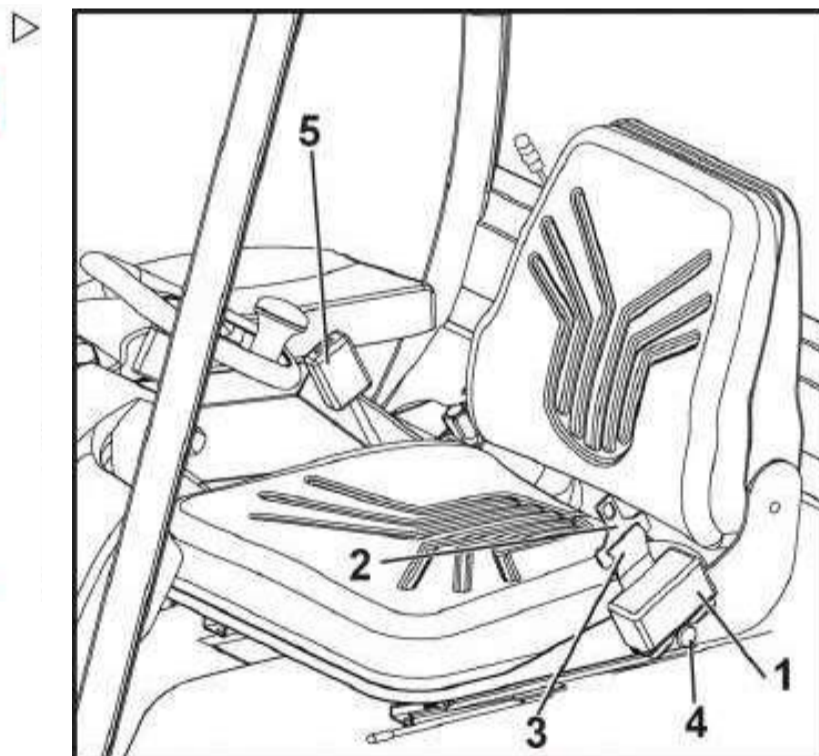

NOTE

The driver should sit as far back as possible when the truck is in use (e.g. when driving, when the lift mast is in motion etc.) so that his back rests against the seat backrest.

Unfastening the seat belt

- Press the red button on the seat belt socket (4) and release the seat belt buckle (2).
- Continue to press the button (4) to make the seat belt return to the retractor (1).

Emergency off switch

▲ DANGER

This switch button is the primary power supply switch. Do not disconnect this switch when performing an emergency stop.

Press the emergency off switch

- Press the emergency off switch(1) and release. This will completely shut down the truck's electrical system.

Pull up the emergency off switch

- Pull up the emergency off switch(1). This will cause the truck's electrical system to start conducting.

NOTE

The truck is only operational after correctly pulling up the emergency off switch.

In the following situations, press the emergency off switch before operating:

First, disconnect the key switch, then press the emergency off switch.

- When preparing to recharge.
- Before changing the battery.
- Before performing operations with the overhead guard lifted.
- Routine maintenance checks.

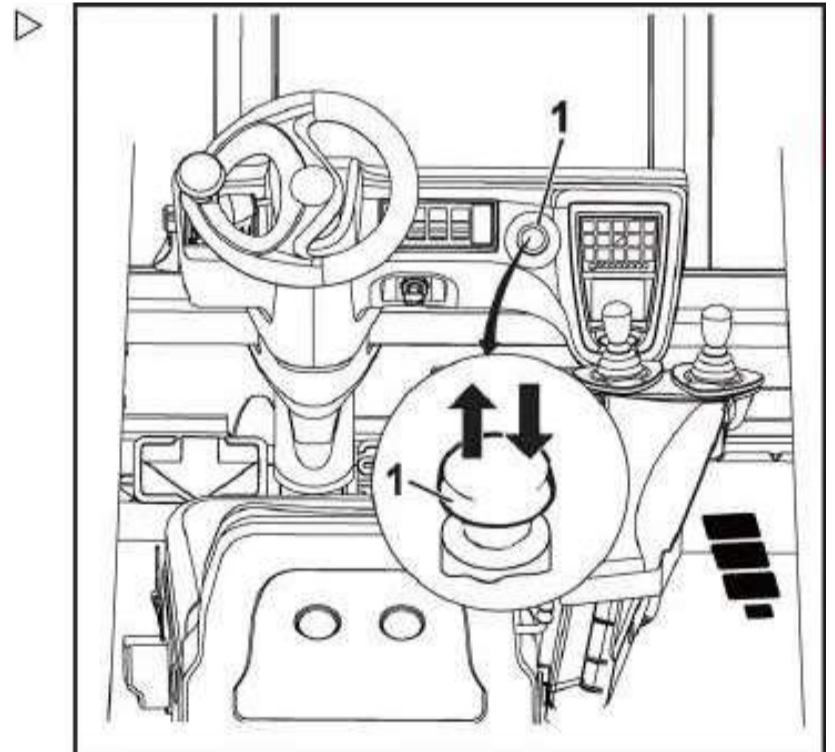

4 Operation

Linde Material Handling



Driving

NOTE

When starting the forklift truck, first pull up the emergency off switch, then turn the keyswitch.

DANGER

Non-standard emergency off switch button operations can easily cause accidents and damage to the power module.

Driving

Driving

WARNING

Taking into account stability and the specified minimum braking distance, do not use the forklift truck on a long slope with a gradient of more than 15%. If you need to use the forklift truck on slopes with higher gradients, please first consult your dealer. The gradabilities given in the type sheet are calculated based on the truck's traction and are only applicable to situations in which the truck must surmount small obstacles or when driving on fairly even road surfaces.

Operating mode should suit road surface conditions (undulant, uneven, etc.), especially in dangerous working areas and when transporting loads.

CAUTION

Please note when using the rear-view mirror that it should only be used to monitor rear traffic conditions.

Reversing is only permitted using direct rear view.

NOTE

The distance from the driver's head to the overhead guard has been reduced in certain Linde forklift trucks (such as the container overhead guard, swivel seat, etc.). Only drivers where the distance from the driver's head to the overhead guard exceeds 30 mm are permitted to operate this kind of forklift truck.

▲ CAUTION

The hydraulic pump motor should be connected when working the steering or working hydraulic equipment.

i NOTE

All control levers in the neutral position.

- Sit on the driver's seat. (This will activate the driver's seat switch.)
- Pull up the emergency off switch(4).

i NOTE

The forklift truck can only work when the emergency off switch is pulled up.

- Fasten the seat belt.
- Insert key(1) and turn clockwise as far as possible.

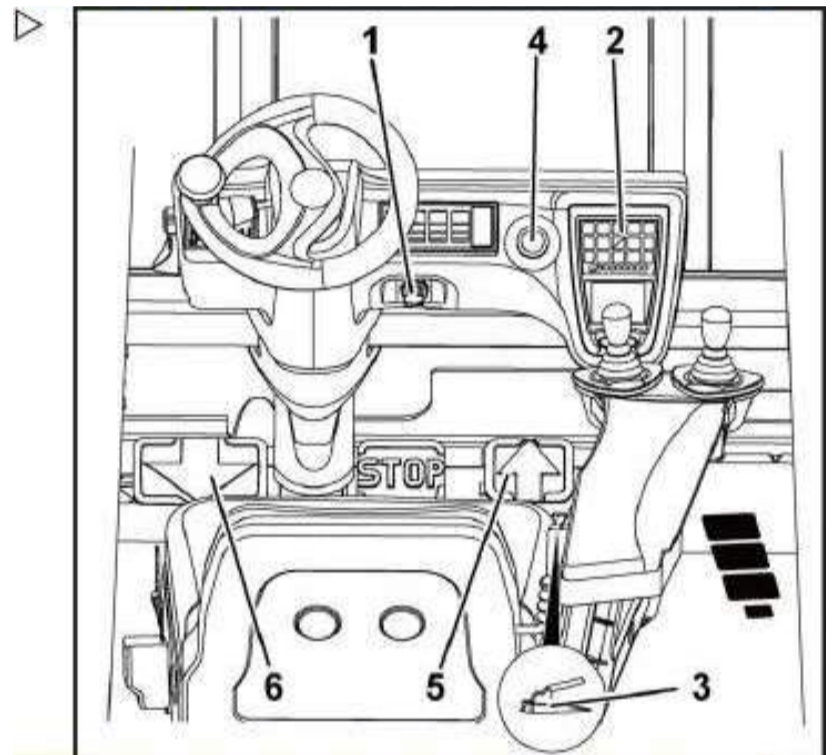

- When the chronograph starting indicator (10) flashes, it shows that the chronograph has started working.
- All alarm lights on the discharge indicator(9) and dashboard will(2) flash (apart from the(7) alarm light, all other alarm lights will go out after approximately 2 seconds).

i NOTE

The joystick and/or accelerator pedal can only be operated after the warning lights have gone out (except warning light(7)).

- Lift the fork slightly, and tilt the lift mast backwards.
- Release the handbrake(3). The alarm light will(7) go out.

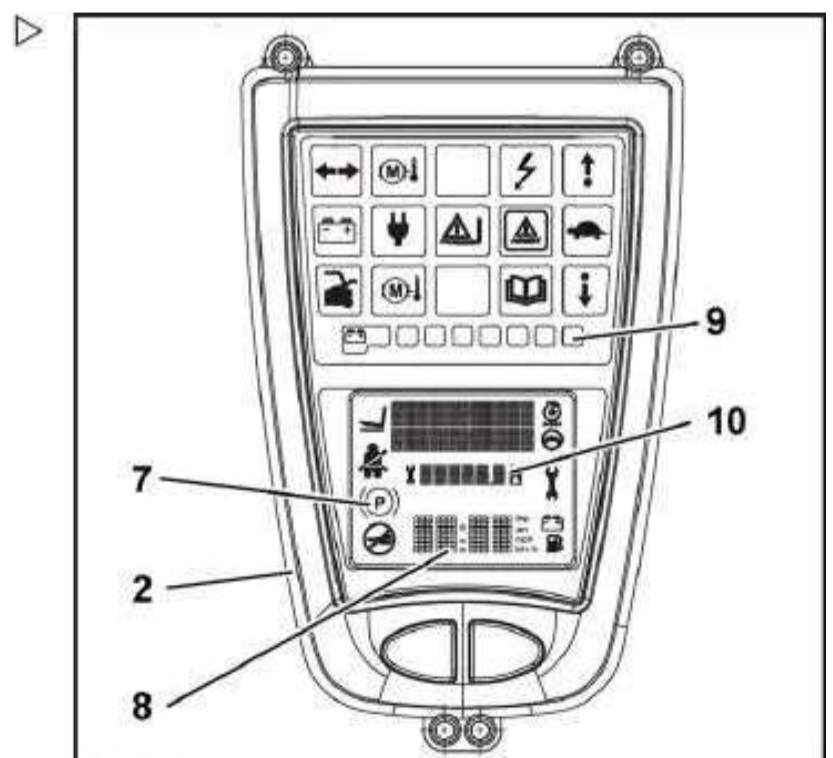

4 Operation

Linde Material Handling



Driving

Forwards

- Smoothly depress the right accelerator pedal(5).

Driving speed accelerates in relation to the increase in pedal travel.

NOTE

Rapidly depressing the pedal will not change the acceleration, as the maximum acceleration is controlled automatically.

Backwards

- Smoothly depress the left accelerator pedal(6).

Driving speed is determined by the pedal travel.

Reversing

- Release the original direction accelerator pedal.
- Depress the opposite direction accelerator pedal. The truck will slow to a halt using electrical braking and then accelerate in the opposite direction.
- Both feet should be placed on the pedals for ease of control when driving.
- The accelerator pedal can be switched from forwards to reverse directly.

NOTE

Rapidly depressing the pedal will not change the acceleration, as the maximum acceleration is controlled automatically. When accepting the forklift, please request a reverse braking demonstration.

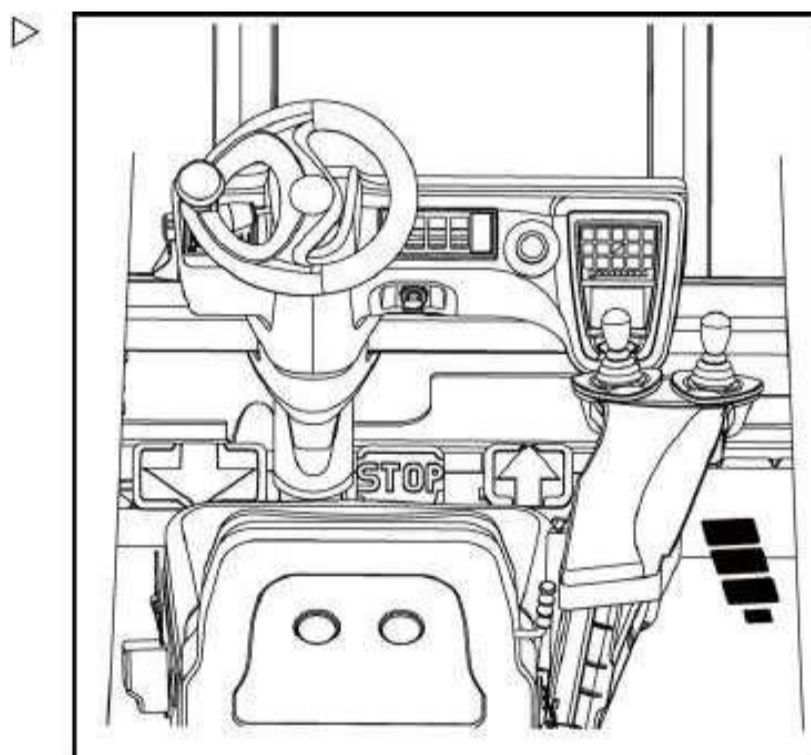
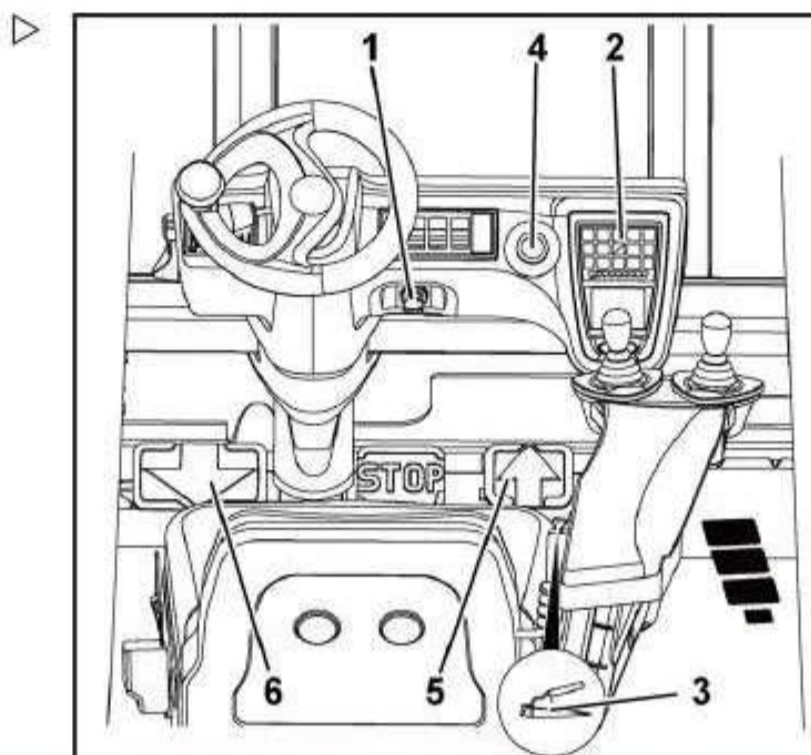

Faults during operation

⚠ CAUTION

If one of the following dashboard warning lights lights up during operation, the forklift truck should be stopped immediately and the reason ascertained.

- Engine temperature at upper limit (red) warning light (1).
- Pre-warning light(2). Motor temperature raised (yellow).
- Electrical system error (red) warning light(3).

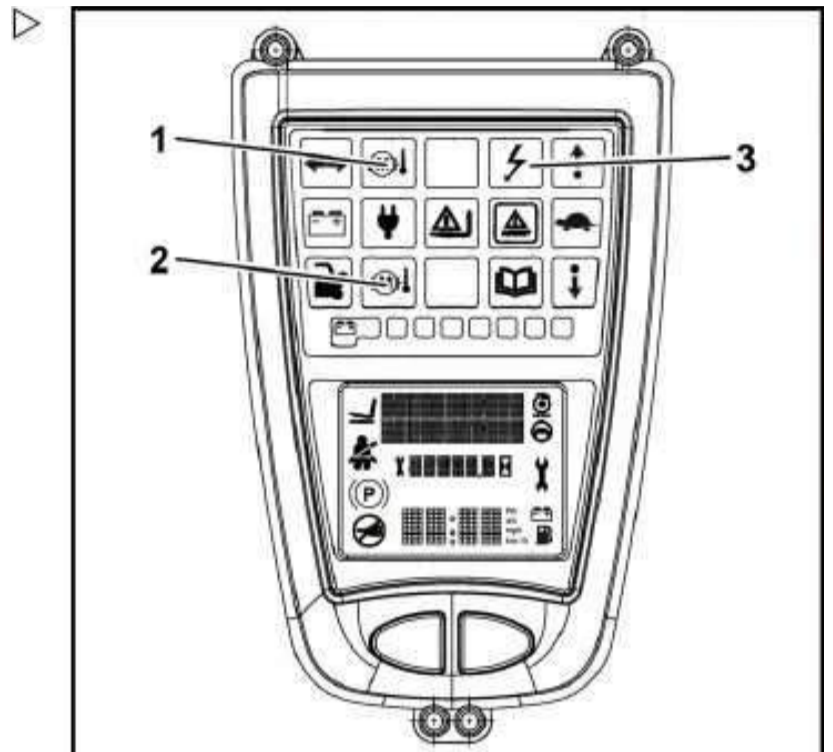

Single-pedal operation (optional)

Driving

⚠ WARNING

Taking into account stability and the specified minimum braking distance, do not use the forklift truck on a long slope with a gradient of more than 15%. If you need to use the forklift truck on slopes with higher gradients, please first consult your dealer. The gradabilities given in the type sheet are calculated based on the truck's traction and are only applicable to situations in which the truck must surmount small obstacles or when driving on fairly

even road surfaces. Operating mode should suit road surface conditions (undulant, uneven, etc.), especially in dangerous working areas and when transporting loads.

⚠ CAUTION

Please note when using the rear-view mirror that it should only be used to monitor rear traffic conditions.

Reversing is only permitted using direct rear view.

i NOTE

The distance from the driver's head to the overhead guard has been reduced in certain Linde forklift trucks (such as the container overhead guard, swivel seat, <https://www.forkliftpdfmanuals.com/>

4 Operation

Linde Material Handling

Linde

Single-pedal operation (optional)

etc.). Only drivers where the distance from the driver's head to the overhead guard exceeds 30 mm are permitted to operate this kind of forklift truck.

⚠ CAUTION

The hydraulic pump motor should be connected when working the steering or working hydraulic equipment.

i NOTE

The direction control lever(4) must be in the neutral position.

All control levers in the neutral position.

- Sit on the driver's seat. (This will activate the driver's seat switch.)
- Pull up the emergency off switch(2).

i NOTE

The forklift truck can only work when the emergency off switch is pulled up.

- Fasten the seat belt.
- Insert key(1) and turn clockwise as far as possible.

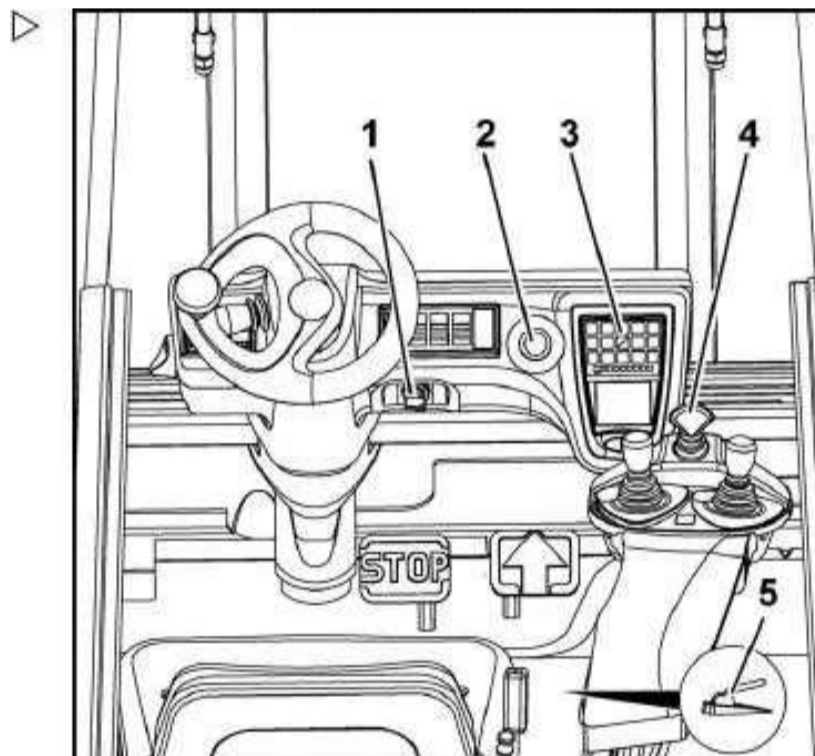

- When the chronograph starting indicator (6) flashes, it shows that the chronograph has started working.
- All alarm lights on the discharge indicator (9) and dashboard will (2) flash (apart from the (7) alarm light, all other alarm lights will go out after approximately 2 seconds).

NOTE

The joystick and/or accelerator pedal can only be operated after the warning lights have gone out (except warning light (7)).

- Lift the fork slightly, and tilt the lift mast backwards.
- Release the handbrake (5). The alarm light will (7) go out.

Forwards

- Push the direction control lever (1) forward.

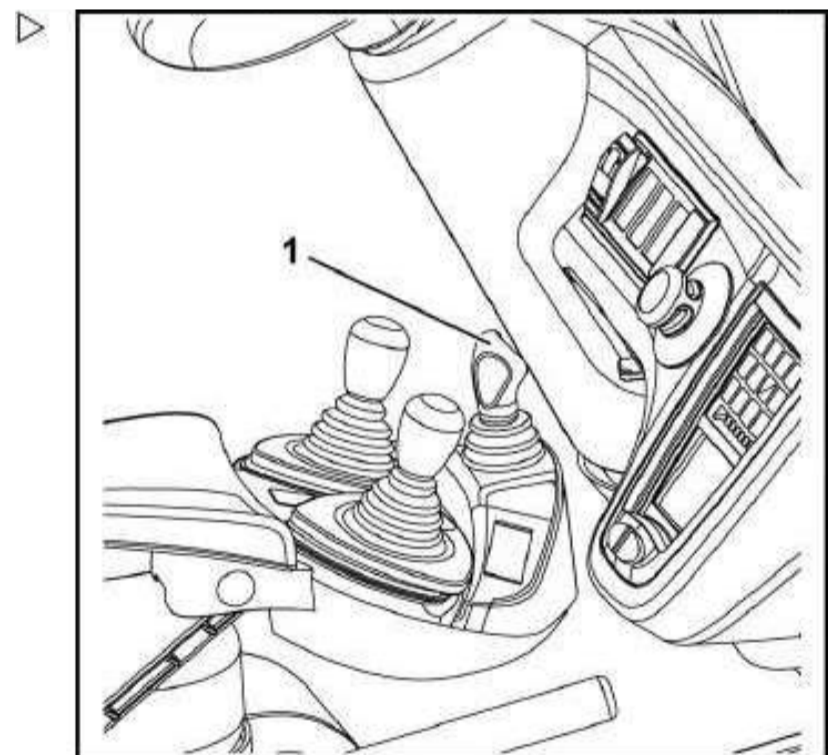
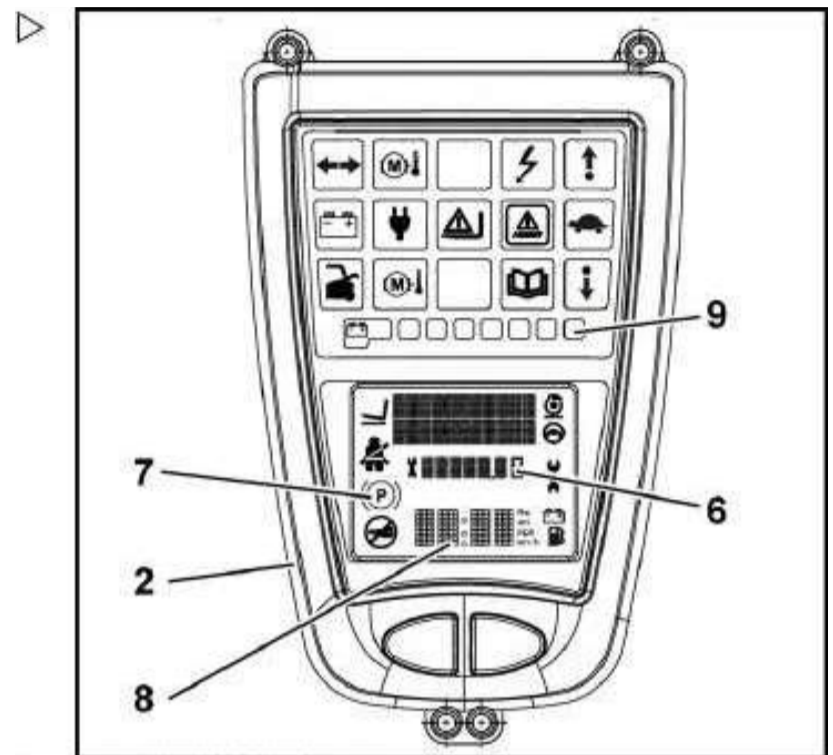

4 Operation

Linde Material Handling

Linde

Single-pedal operation (optional)

- Smoothly depress the left accelerator pedal(6).

Driving speed accelerates in relation to the increase in pedal travel.

i NOTE

Rapidly depressing the pedal will not change the acceleration, as the maximum acceleration is controlled automatically.

Backwards

- Push the direction control lever(1) back.
- Smoothly depress the left accelerator pedal(6).

Driving speed is determined by the pedal travel.

Reversing

- Release the original direction accelerator pedal.
- Pull the direction control lever (1) in the opposite direction.
- Depress the accelerator pedal(6) again to reverse the acceleration.

The direction control lever can switch directly from forwards to reverse without releasing the accelerator pedal. The truck will slow to a halt using electrical braking and then accelerate in the selected direction.

i NOTE

Rapidly depressing the pedal will not change the acceleration, as the maximum acceleration is controlled automatically. When accepting the forklift, please request a reverse braking demonstration.

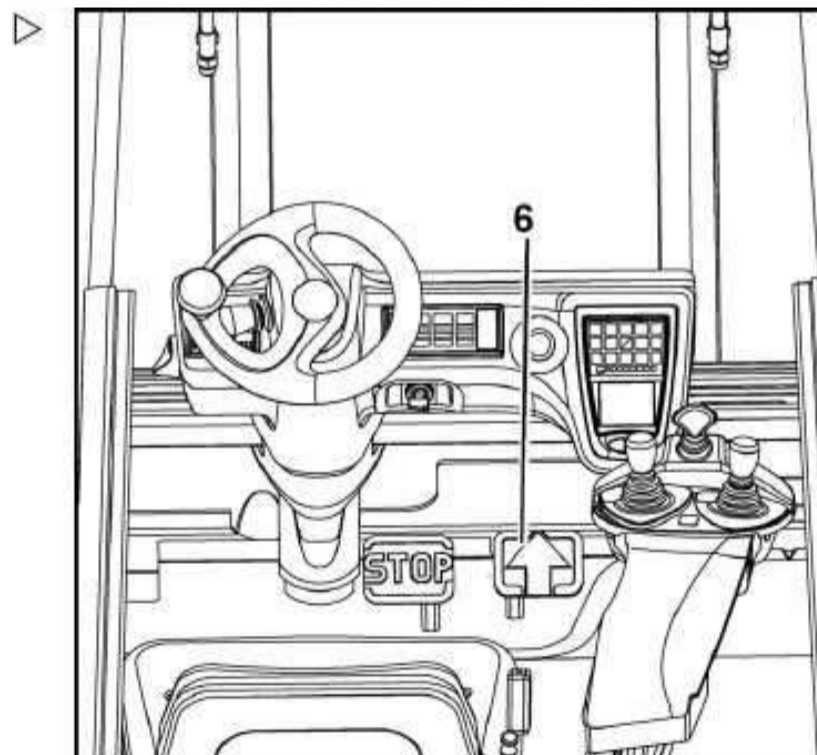
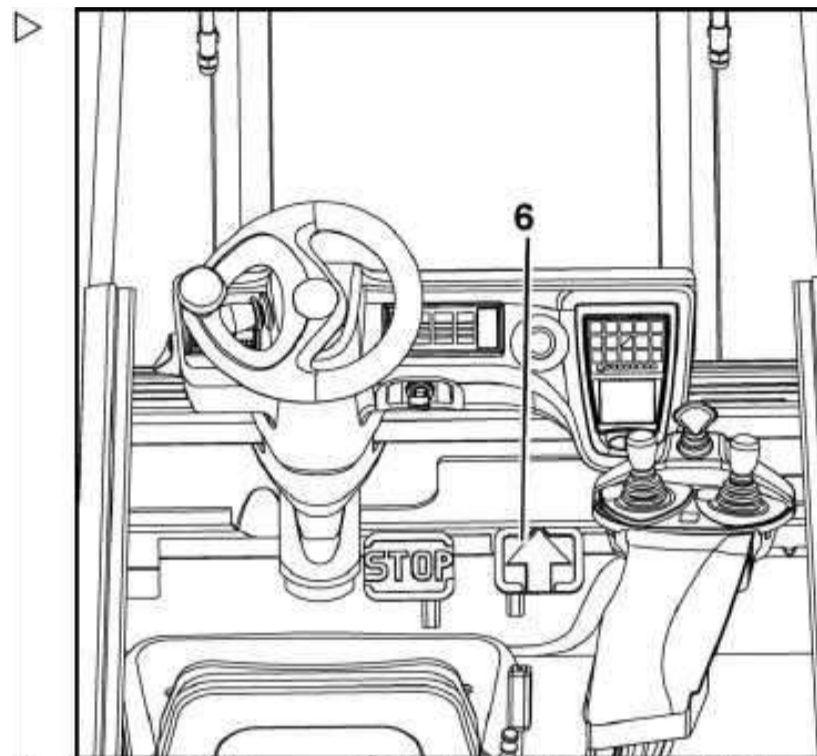

Faults during operation

⚠ CAUTION

If one of the following dashboard warning lights lights up during operation, the forklift truck should be stopped immediately and the reason ascertained.

- Engine temperature at upper limit (red) warning light(1), pre-warning alarm light(2).
- Motor temperature raised (yellow).
- Electrical system error (red) warning light(3).

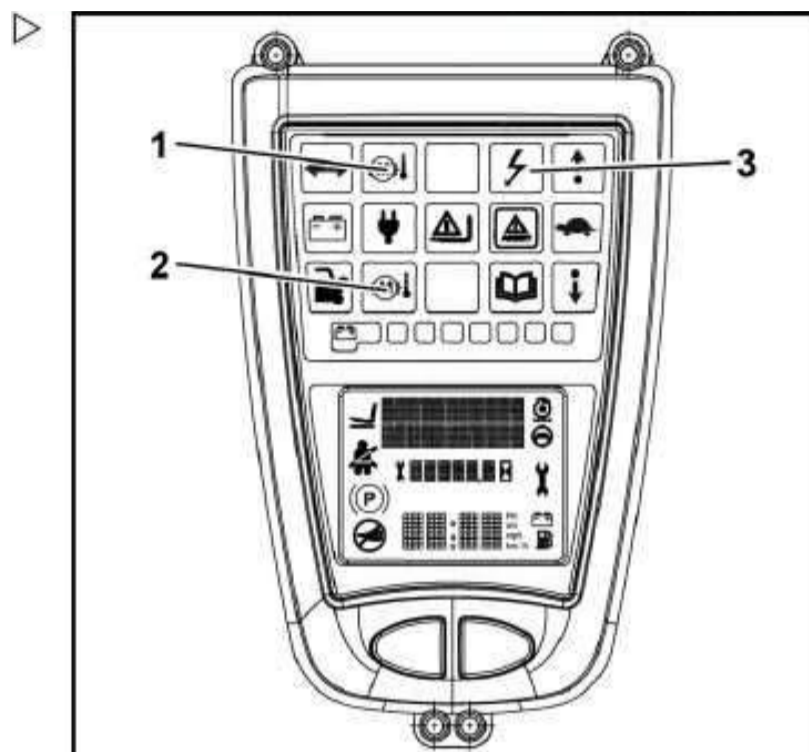

Steering system

Hydrostatic steering enables the steering wheel to be moved with only a very small amount of force when turning. This characteristic is especially applicable when operating in narrow passages.

- Turn the steering wheel right and left when driving the forklift truck.

⚠ DANGER

The forklift truck cannot be used when there is a fault in the steering system.

Please contact your dealer if steering is difficult or clearance is too large.

Truck Model	Turning radius
E 16 C	1512 mm
E 16 P	1878 mm
E 20 P	1900 mm

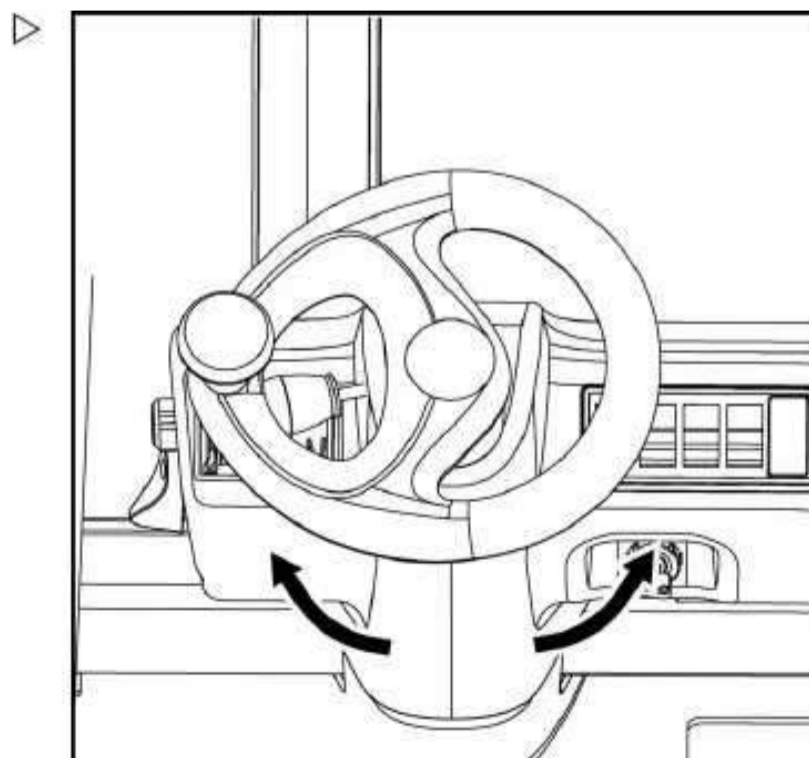

4 Operation

Brake system

Linde Material Handling



Brake system

DANGER

Risk of accident or casualties if brake system is faulty.

Use of the industrial truck should not be continued under any circumstances in which the brake system experiences a fault. Please contact your authorised dealer immediately if the braking system shows any significant defects or signs of wear and tear.

DANGER

There are a number of factors that can affect the truck's braking performance, including oil viscosity. Using any oil other than that specified by the manufacturer (with a different viscosity) will affect braking performance and increase the risk of accidents and loss of life.

Therefore, only use the oil specified by the manufacturer (see Recommendations for consumables). Please contact your authorised dealer.

Driving brakes, regenerative brakes

- Release the accelerator pedal and depress the reverse direction accelerator pedal. At this time, the truck generates regenerative braking.
- Release the accelerator pedal (1 or 3) and depress the brake pedal (2) until the truck decelerates to a stop

NOTE

Please request your Linde dealer to demonstrate the operation of the regenerative brakes when accepting delivery of the forklift truck.

Foot brake/emergency brake

The stop pedal is positioned between the accelerator pedals and is used for hydraulic operation of the multi-disc brake.

- Release the accelerator pedal (1 or 3). The pedal will return to the central position.
- Depress the brake pedal (2). This will exert hydraulic braking on the multi-disc brake.

⚠ CAUTION

When performing emergency braking, depress the brake pedal located between the two accelerator pedals.

We recommend that the driver be thoroughly familiar with this function, as well as with the effect of performing emergency braking when not carrying a load. Training should be carried out at slow speeds on roads without other vehicles. Depressing the brake pedal stops the brake discs of the two motors hydraulically.

Linde automatic brake (LBC)

- If the accelerator pedal (1 or 3) is released while driving, the pedal will automatically return to the central position and the truck will brake automatically.

i NOTE

The Linde diagnostic unit can be used to cancel this function.

Hand brake

Use the mechanical hand brake to stop. The disc brakes inside the drive axle are tightened by a cord.

i NOTE

When the parking brake is exerted, the drive current drops and the dashboard warning light (1) flashes.

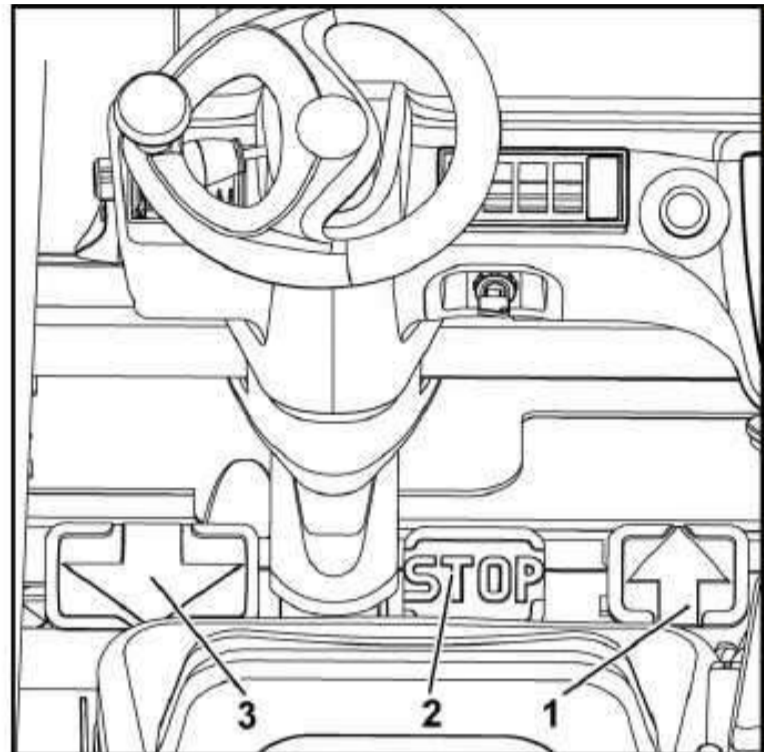

4 Operation

Linde Material Handling

Linde

Operating the lift mast and attachments using the centralised control lever (joystick)

Exerting the hand brake

- Pull backwards on the parking brake lever (3).

Release the hand brake/parking brake

- Press the release button (2) on the parking brake and push the handle forwards.

▲ DANGER

Do not use trucks with faulty brakes.

Please contact your dealer if the braking system of your forklift truck shows significant wear and tear or malfunction.

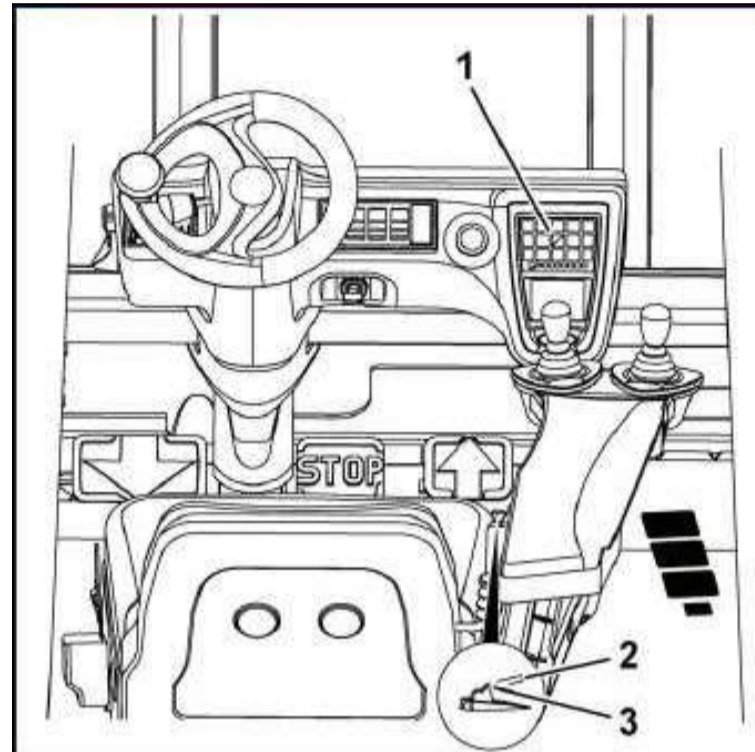

Operating the lift mast and attachments using the centralised control lever (joystick)

Operating the lift mast and attachments using the centralised control lever (joystick)

▲ WARNING

Practical training should be provided for operating personnel to ensure the correct operation of the lift mast and lifting equipment. Keep your hands away from the movement range of the lift mast, and do not place them between the lift mast and the truck.

The control lever must be operating smoothly and slowly. Lifting, lowering and tilting speeds are determined by the displacement of the control lever. The control lever automatically returns to its original position after being released.

i NOTE

Take note of the operating symbols with arrows.

i NOTE

Operating the lift mast and attachments using the centralised control lever (joystick)

When the control lever is pushed into the central position (approximately 45 degrees), two functions can operate simultaneously (for example, lifting and tilting).

Tilting the lift mast forwards

- Push the control lever (1).

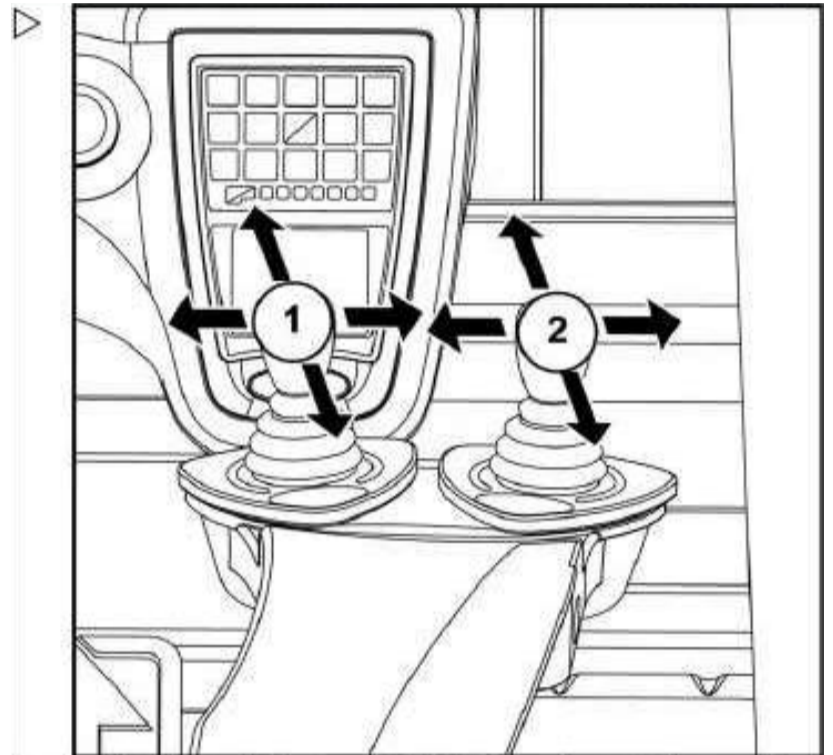

Tilting the lift mast backwards

- Pull the control lever (1).

Lifting the fork carriage

⚠ WARNING

Do not stand on the fork arms during lifting, due to the danger of falling or being hit.

- Push the control lever (1) to the right.

Lowering the fork carriage

- Push the control lever (1) to the left.

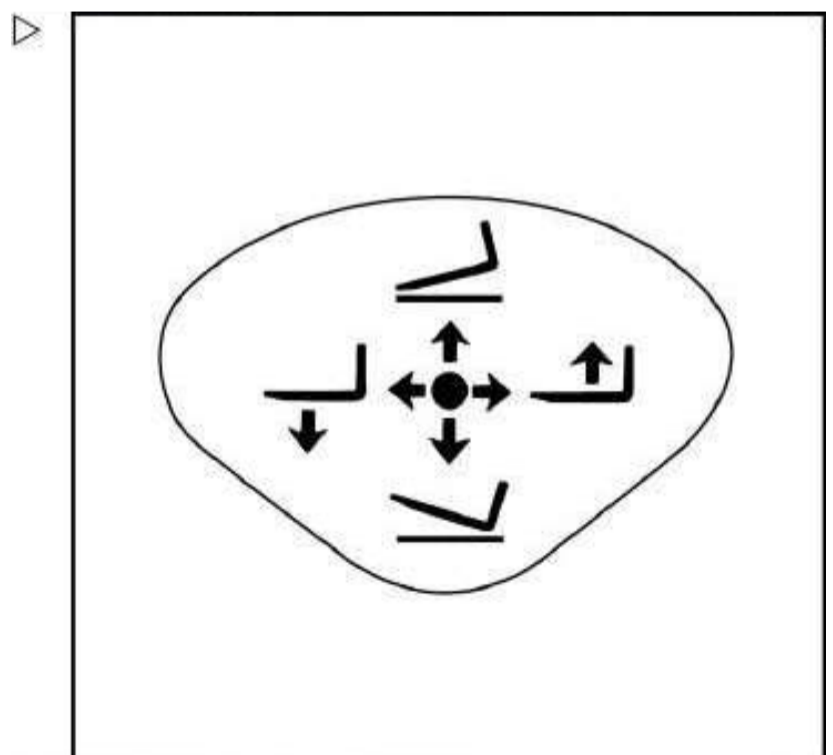

4 Operation

Linde Material Handling



Operating the lift mast and attachments using the centralised control lever (joystick)

Operating attachments

Attachments are optional equipment purchased by the user and installed onto the truck (for example: lateral forks, clamps etc.). Give careful attention to the working pressures and

operating instructions for each attachment. An additional operating lever should be installed for use by the attachments.

NOTE

After installing each attachment, a label should be attached to the battery hood, explaining the truck's load capacity after installing the attachment. An attachment operating notice should also be attached to the back of the attachment control lever.

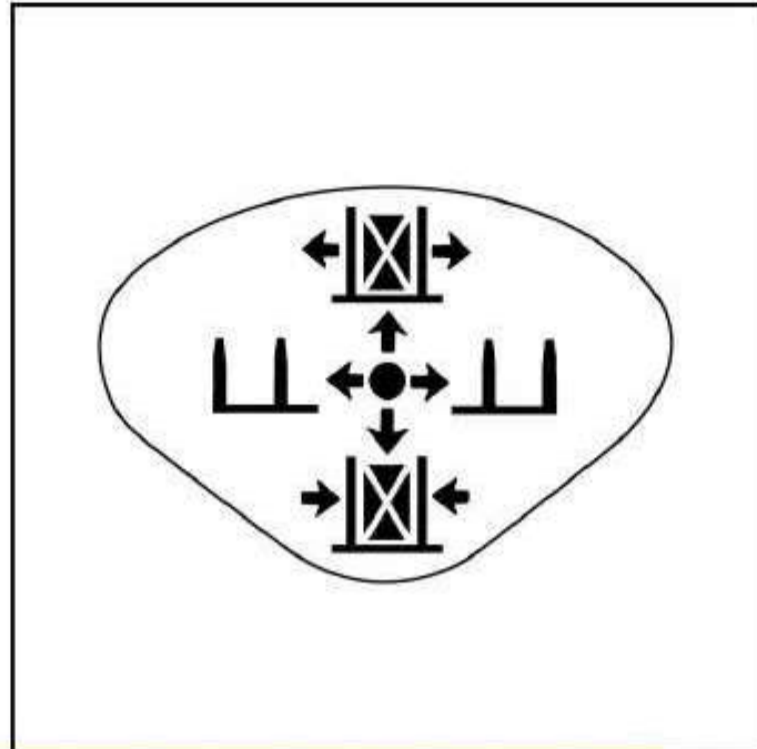

Operating the lateral forks

- Push the control lever (2) to the left to move the fork carriage to the left.
- Push the control lever (2) to the right to move the fork carriage to the right.

Operating the clamp

- Push the control lever (2) forwards to release the clamp.
- Pull the control lever (2) back to engage the clamp.

CAUTION

If the attachment was not supplied with the truck, it can only be used if verified by your Linde dealer and safe operation of the truck is guaranteed in terms of load capacity and stability after installation of the attachment.

Single lever operation of the lift mast and attachments

Single lever operation of the lift mast and attachments

⚠ WARNING

Practical training should be provided for operating personnel to ensure the correct operation of the lift mast and lifting equipment. Keep your hands away from the movement range of the lift mast, and do not place them between the lift mast and the truck.

The control lever must be operating smoothly and slowly. Lifting, lowering and tilting speeds are determined by the displacement of the control lever. The control lever automatically returns to its original position after being released.

i NOTE

Take note of the operating symbols with arrows.

i NOTE

When the control lever is pushed into the central position (approximately 45 degrees), two functions can operate simultaneously (for example, lifting and tilting).

Tilting the lift mast forwards

- Push the control lever (2).

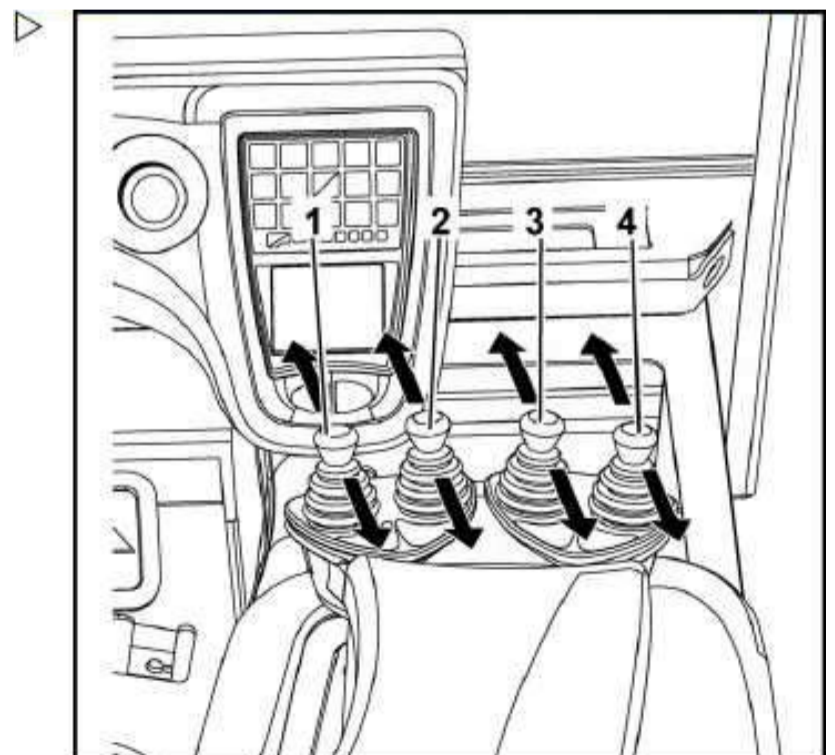

4 Operation

Linde Material Handling



Single lever operation of the lift mast and attachments

Tilting the lift mast backwards

- Pull the control lever (2).

Lifting the fork carriage

⚠ WARNING

Do not stand on the fork arms during lifting, due to the danger of falling or being hit.

- Pull the control lever (1).

Lowering the fork carriage

- Push the control lever (1).

Operating attachments

Attachments are optional equipment purchased by the user and installed onto the truck (for example: lateral forks, clamps etc.). Give careful attention to the working pressures and operating instructions for each attachment. An additional operating level should be installed for use by the attachments.

NOTE

After installing each attachment, a label should be attached to the battery hood, explaining the truck's load capacity after installing the attachment. An attachment operating notice should also be attached to the back of the attachment control lever.

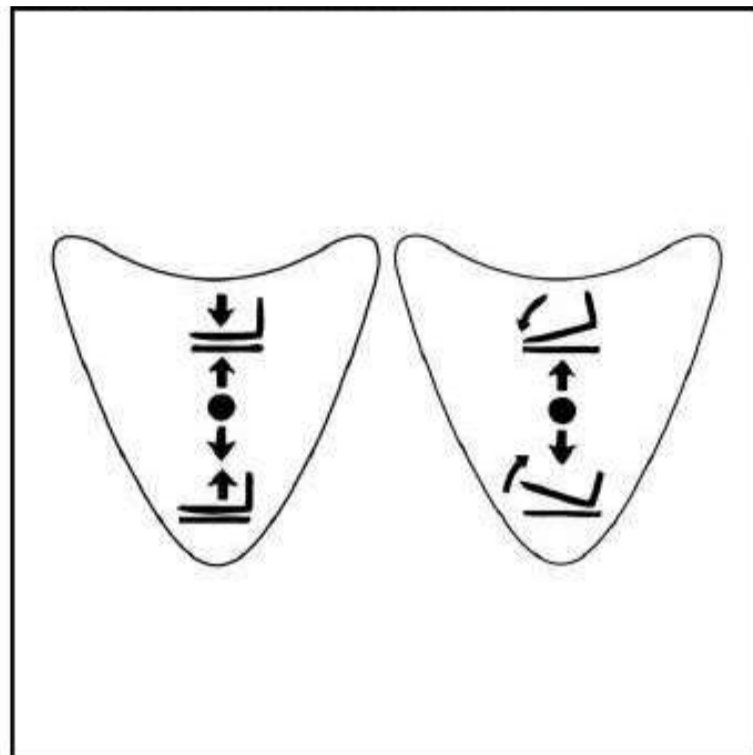

Operating the lateral forks

- Push the control lever (3) forwards to move the fork carriage to the left.
- Pull the control lever (3) back to move the fork carriage to the right.

Operating the clamp

- Push the control lever (4) forwards to release the clamp.
- Pull the control lever (4) back to engage the clamp.

⚠ CAUTION

If the attachment was not supplied with the truck, use is only permitted if the attachment is verified by your Linde dealer and safe operation of the truck is guaranteed in terms of load capacity and stability after installation of the attachment.

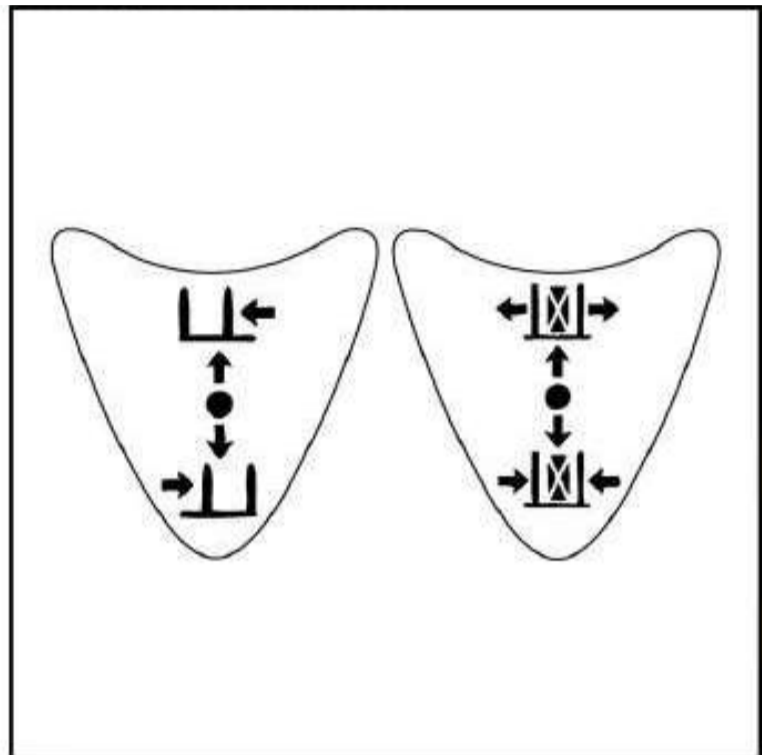

Working spotlights*, windscreen wipers*, headlights*, direction indicator lights*

Working spotlights

⚠ CAUTION

Additional electrical devices (lamps, driver's seat radiator etc.) must be connected to the independent harness plug connector for use by these devices. For any connections outside of this range, you must obtain permission from Linde Corp.

Only qualified, professional technicians who understand how to apply these standards are permitted to carry out this operation.

i NOTE

The location of the switch settings (I and II) may vary between different models of forklift truck.

Please comply with the notes on the switch prompt.

4 Operation

Linde Material Handling



Working spotlights*, windscreen wipers*, headlights*, direction indicator lights*

Conducting the front working lights

Slide the joint switch (1) to turn on or off the front working lights.

Conducting the back working lights

➤ Slide the joint switch (2) to turn on or off the back working lights.

Turning on the front windscreen wiper

- Press the switch (3) down halfway to switch the front windscreen wipers to intermittent.
- Press the switch down completely to switch the front windscreen wipers to continuous.

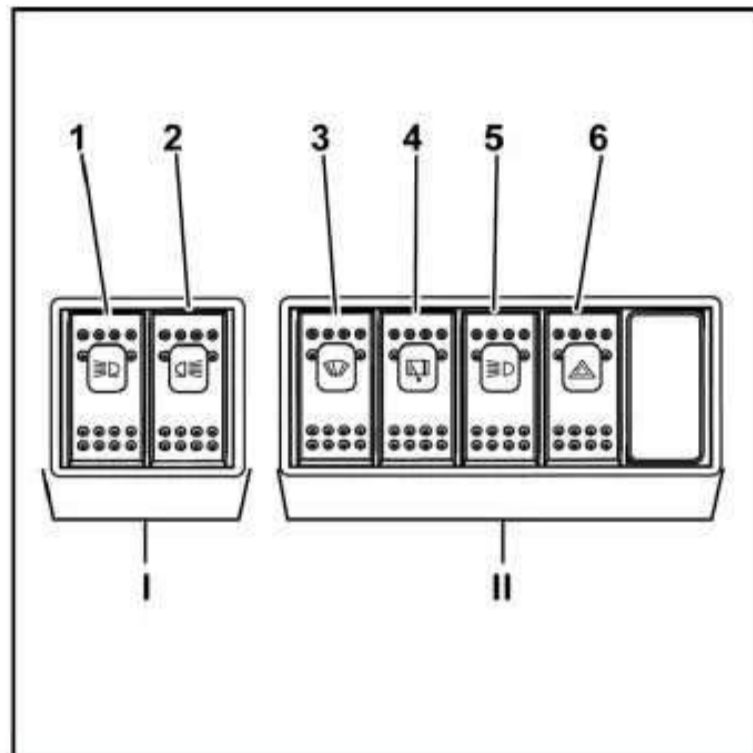

Turning on the rear windscreen wipers

- Press the switch (4) down halfway to switch the rear windscreen wipers to intermittent.
- Press the switch down completely to switch the rear windscreen wipers to continuous.

Turning on the lights

- Press the light switch (5) down halfway to turn on the side lights and marker lights.
- Press the light switch down completely to turn on the dipped beam headlights.

Turning on the hazard warning lights

- Press down the hazard warning light switch (6).

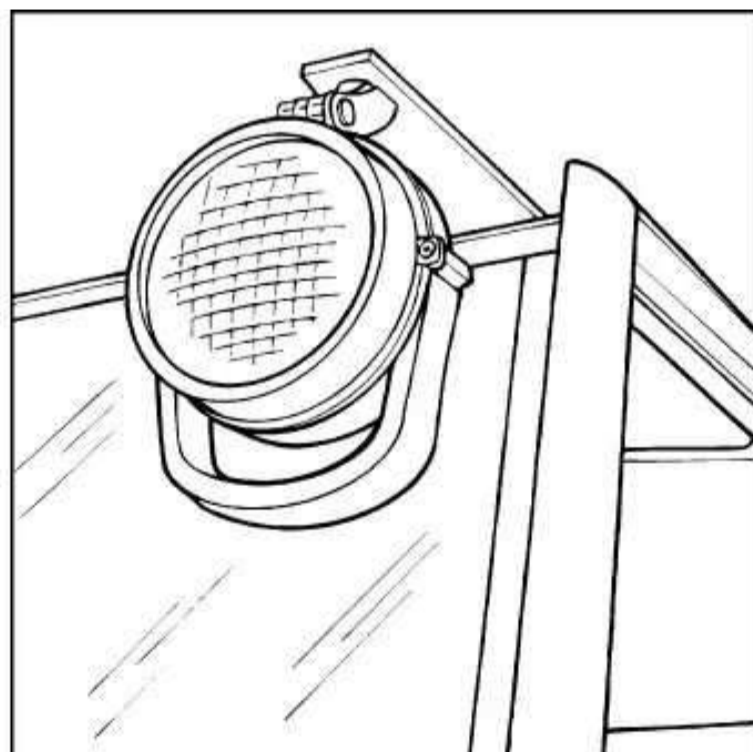

Turning on the direction indicators

- Push the turning indicator light switch (7) on the steering wheel forwards or backwards to make the right or left turning light flash.

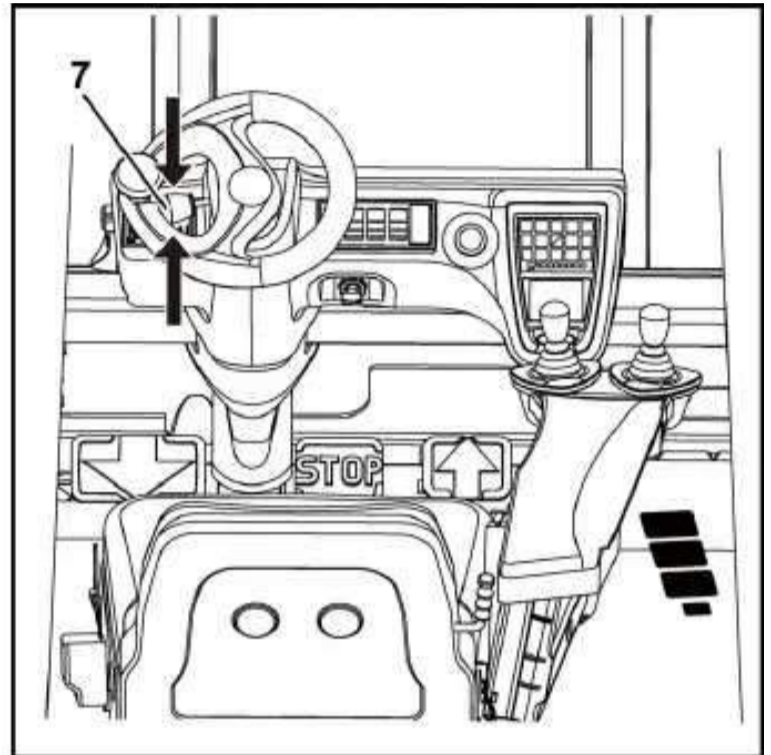

Horn, electrical system cover

Horn operation

The horn can give a warning signal at junctions or places with poor visibility.

- Pressing the horn button will make the horn sound.

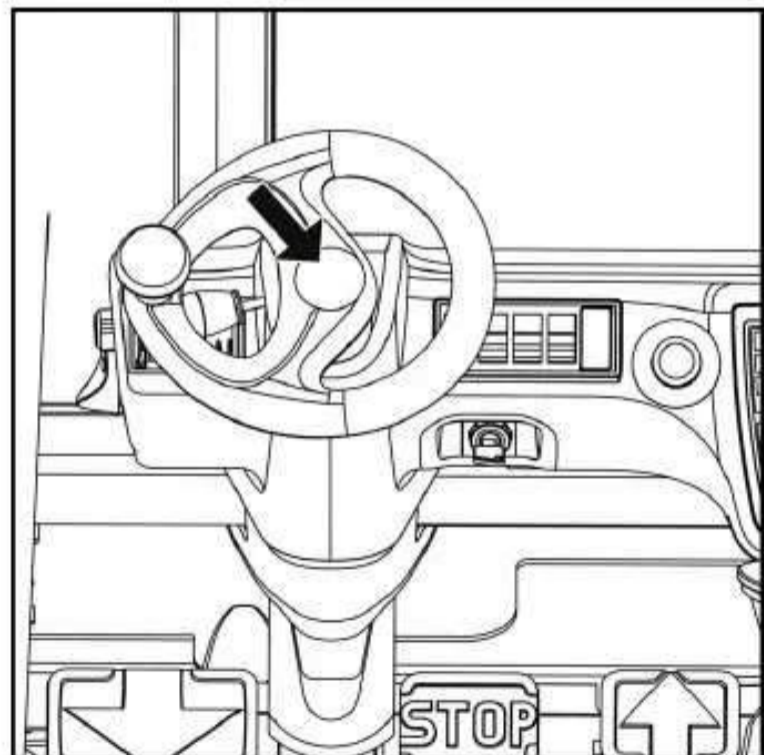

4 Operation

Linde Material Handling



Fuses

Disassembling/installing the electrical system cover plate

- Lower the fork carriage.
- Tilt the lift mast forwards slightly. The truck must be stationary on the ground.
- Exert the hand brake.
- Press the emergency off switch.
- After disassembling the cover plate's 4 mounting screws, disassemble the electrical system cover plate on the counterweight.
- After carrying out maintenance on the electrical system, reinstall the cover plate(2) onto the counterbalance.

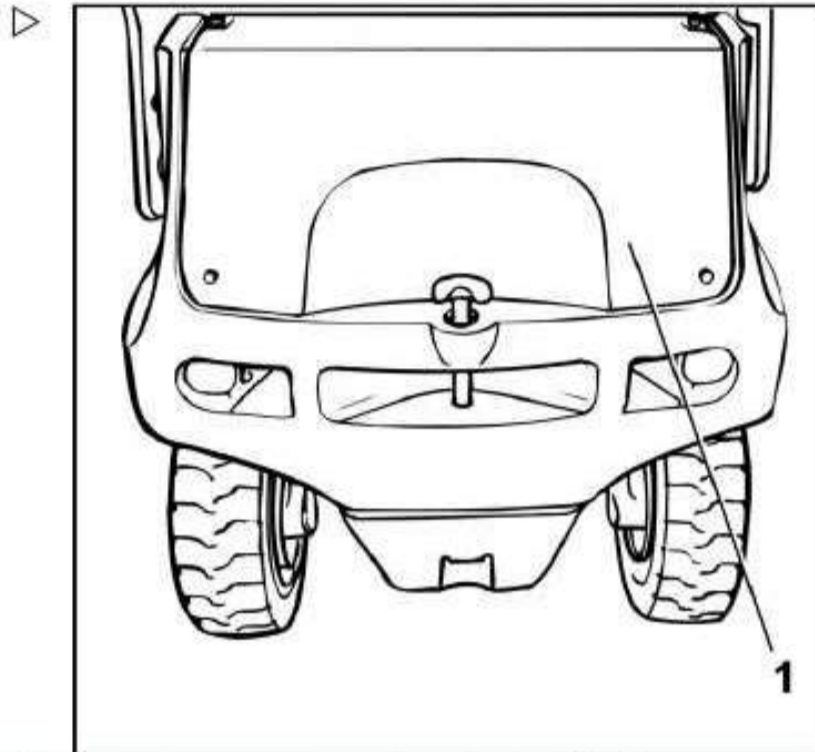

Fuses

Checking and replacing the fuses

 NOTE

The electrical system and fuse installation is in the counterweight.

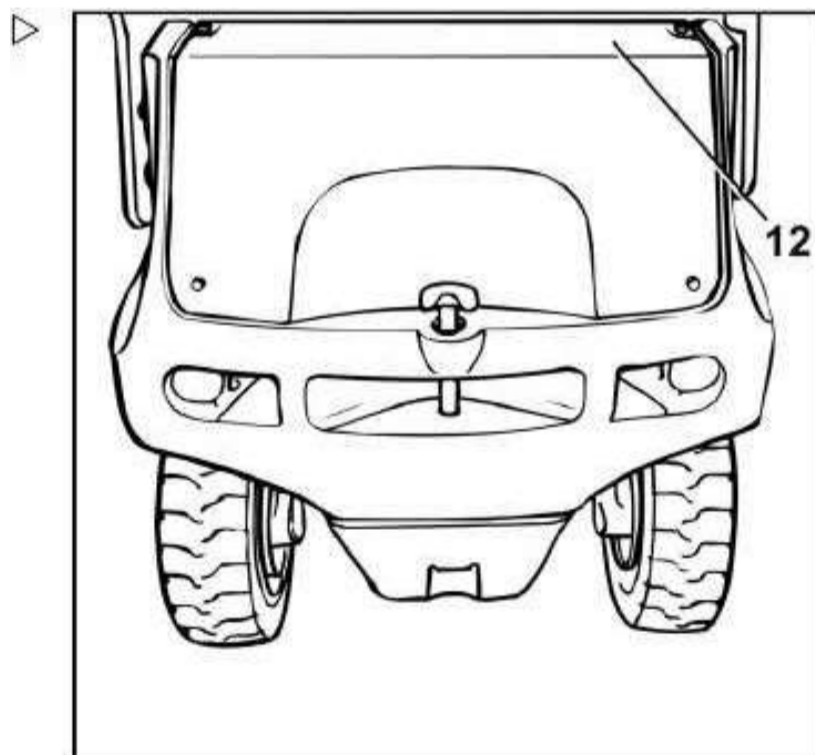

- Open the cover to the electrical system.
- Remove the fuse box (9) cover (10).

The fuse protects the following circuits: pay attention to the numbers on the fuse box.

▲ CAUTION

Only genuine Linde high voltage fuses can be used as replacements.

- (1) Control circuit fuse (1F8) 5 A 80 V
- (2) Battery discharge indicator (F7) 10 A 80 V
- (3) Hydraulic control circuit (2F5) 5A 80 V
- (4) Fan (9F5) 5 A 80 V
- (5) Meter (F4) 5 A 32V
- (6) Transformer (F3) 10A 80 V
- (7) Master control circuit (F2) 15 A 80 V
- (8) Horn (4F1) 10 A 80 V

Main circuit fuse

These 2 fuses protect the following main circuits:

- (13) left and right traction motors (1F1) 355 A
- (14) Hydraulic pump motor (2F1) 300 A

Light fuse

NOTE

The fuses for the optional lights are located under the cover sheet (1) to the right side of the driver's seat.

- Remove the screws (4 screws).
- Remove the electrical cover sheet (1).

NOTE

Use one or two fuse boxes, according to the number of lights installed.

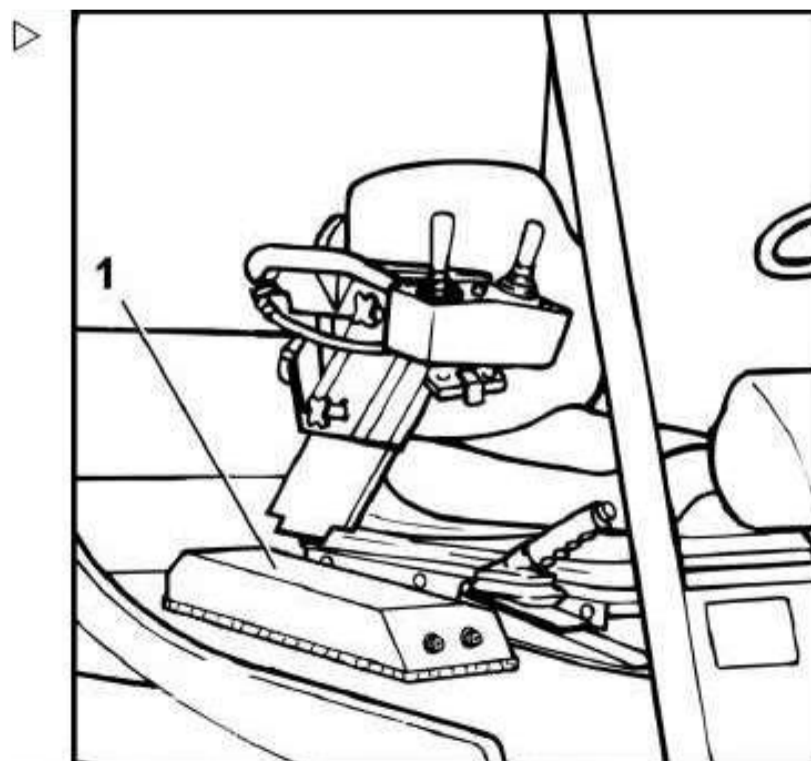
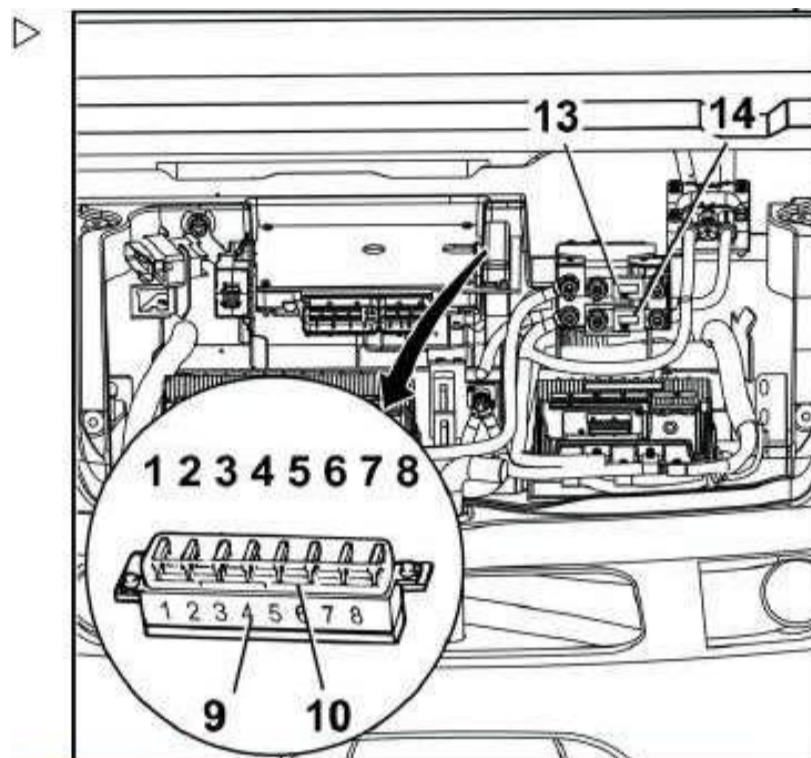

4 Operation

Before loading

Linde Material Handling



➤ Fuse box (A)

Fuse box (A)

- (1) Working spotlights (5F21) 15 A
- (2) Flashing lights (5F22) 15 A
- (3) left headlight (5F23) 10 A
- (4) right headlight (5F24) 10 A
- (5) left side light (5F25) 5 A
- (6) right side light (5F26) 5 A

Fuse box (B)

- (1) Windscreen wiper (9F11) 10 A
- (2) Windscreen wiper (9F12) 20 A
- (3) Relay (9F13) 1 A
- (4) Transformer, working spotlight (9F14) 20 A
- (5) Radiator (9F15) 20 A
- (6) Radiator (9F16) 20 A

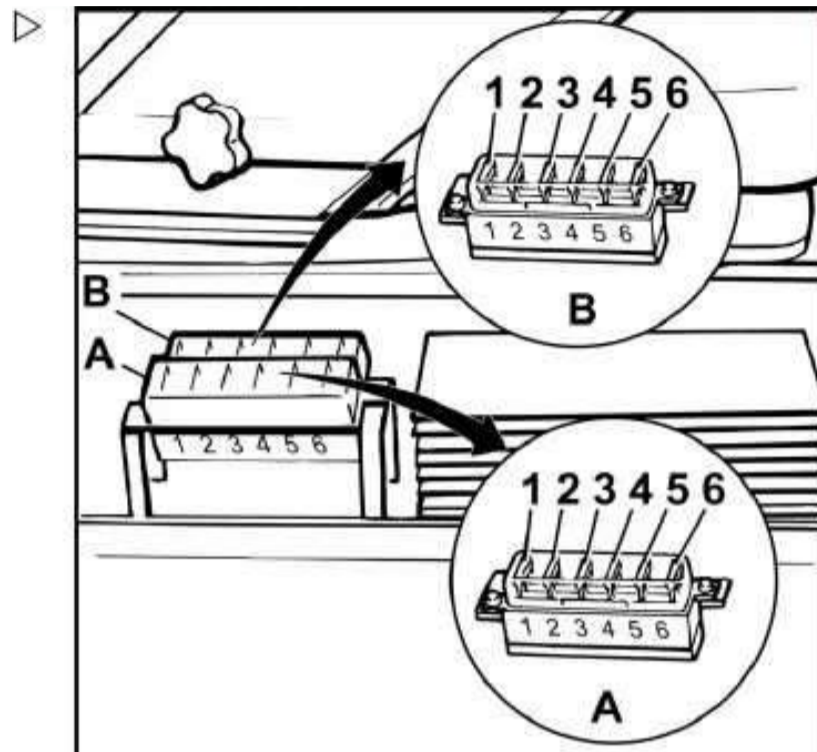

Before loading

Please see the load diagram before lifting goods (1).

If equipped with attachments, pay attention to the load label (2).

DANGER

The parameters in the load diagram and on the labels apply to compact, uniform loads. These load limits must not be exceeded. Exceeding the load limits will affect the stability of the forklift truck and the strength of the lift mast.

The maximum load is determined by the lift height and load centre.

NOTE

In the following situations:

- Eccentric load or swinging goods;
- Lift mast tilted forwards or goods high above the ground during transport;
- Load centre of gravity distance is excessively long;
- Before operating attachments.
- Wind force reaches grade 6

attention should be given to the load limits before transport and your Linde dealer should be contacted.

E.g.:

Load centre of gravity distance 600mm

Lift height 6000mm

- Make a vertical line at the abscissa for a centre of gravity distance of 600mm that intersects with the diagonal line for a lift height of 6000mm.
- The reading at the point where the ordinate intersects with the horizontal line that passes through this point of intersection is the maximum permitted load.
- Therefore, the reading for the maximum permitted load is 1000kg

The corresponding loads relative to other lift heights and load centre distances can also be obtained in this way. This value is for an evenly distributed load on two fork carriages.

1 Maximum lift load unit: kg (kilograms)

2 Lift height unit: mm (millimetres)

3 Forklift model for this maximum load

4 Load centre distance starting from the surface of the fork arm unit: mm (millimetres)

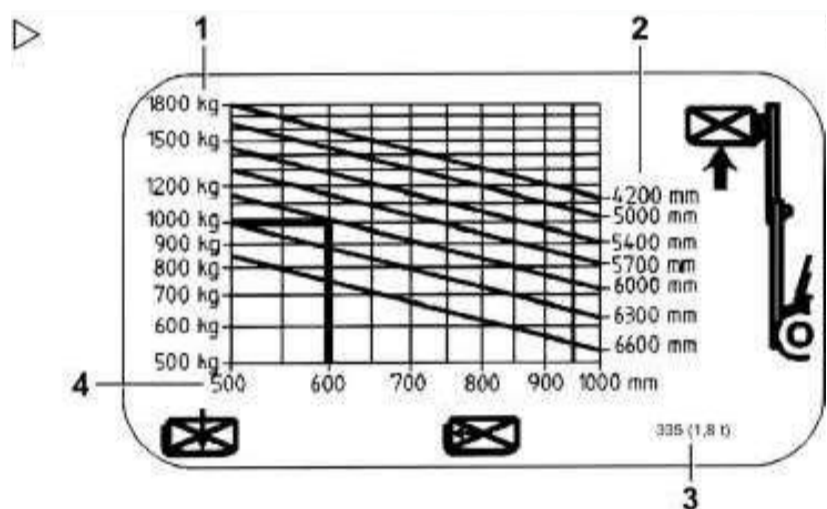
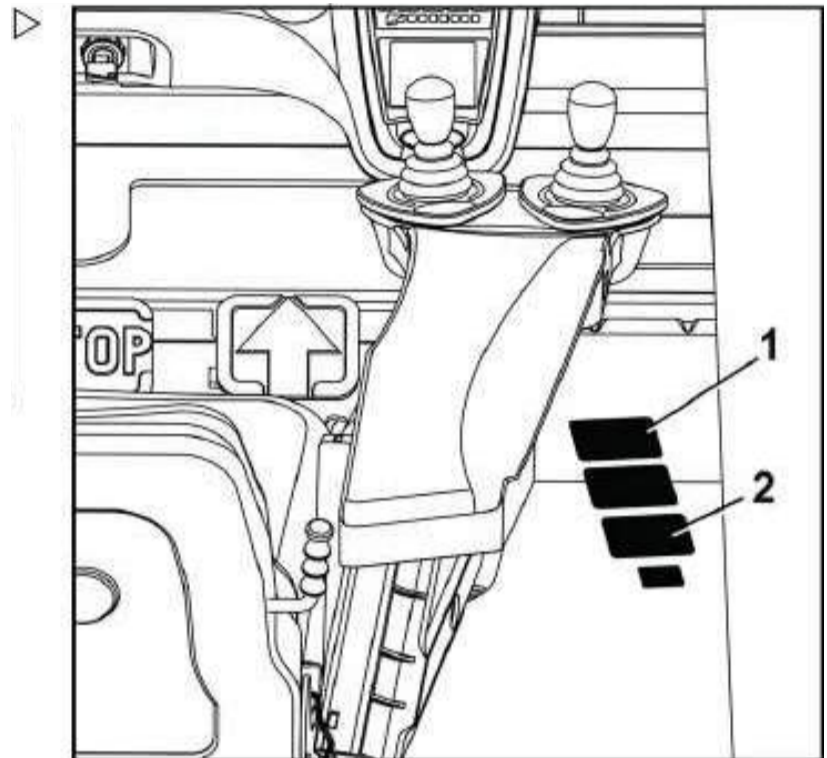

4 Operation

Linde Material Handling



Loading

Loading

Adjusting the fork spacing

- Toggle the fork positioning lock.
- Move the forklift truck closer to or further away from the goods to be lifted according to their size. Note that the two forks should be equidistant from the centreline of the forklift truck.
- Insert the positioning lock into the notch.

NOTE

The centre of gravity of the goods should be at the centre of the fork arms.

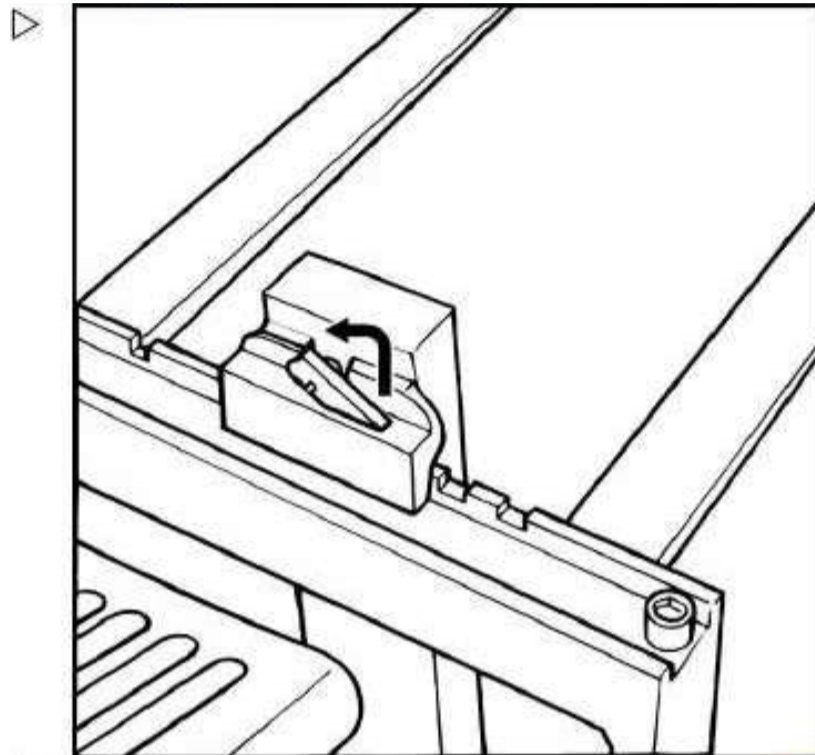

Loading

WARNING

Do not stand on the goods being lifted due to the danger of falling or being hit.

WARNING

Lift the goods, and make sure that they are within the load range of the truck to avoid toppling and falling.

If necessary, use a load backrest*.

- Approach lifted goods carefully and as accurately as possible.
- Place the lift mast in a vertical position.
- Lift or lower the fork carriage to a suitable position.
- Drive the truck forwards carefully, and insert the fork arms beneath the goods, ensuring that the goods are leaning against the vertical section of the fork arm as much as possible and taking care that they do not touch adjacent goods.
- Lift the fork carriage until the fork arms are firmly supporting the goods.

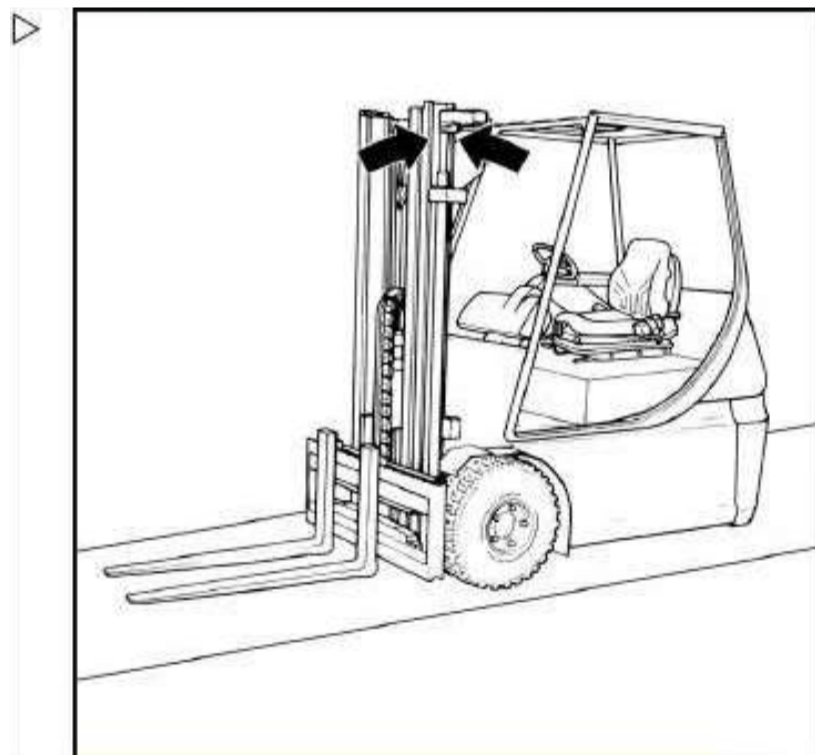

- Reverse the forklift truck until the lifted goods separate from the other stacked goods.
- Tilt the mast back.

▲ CAUTION

Do not stand below lifted goods. When driving, the goods should be as close to the ground as possible, and the lift mast tilted back.

Transport

NOTE

The consignor should secure the goods safely during transport. Attention should be given to appropriate stacking of the goods, to avoid damage to the packaging of the goods, the pallet etc. Responsibility for the safe loading of the goods lies with the transportation personnel.

- When driving with a load, the goods must not lean to one side (such as when fitted with lateral forks).
- Goods should be close to the ground during transport.
- The truck absolutely must not turn or travel in a horizontal direction when moving up a ramp.
- If the field of vision is poor, ask a guide for assistance.
- If the goods on the fork arms are stacked too high, so that they block the line of sight, then the truck must be driven in reverse, unless moving up a slope.

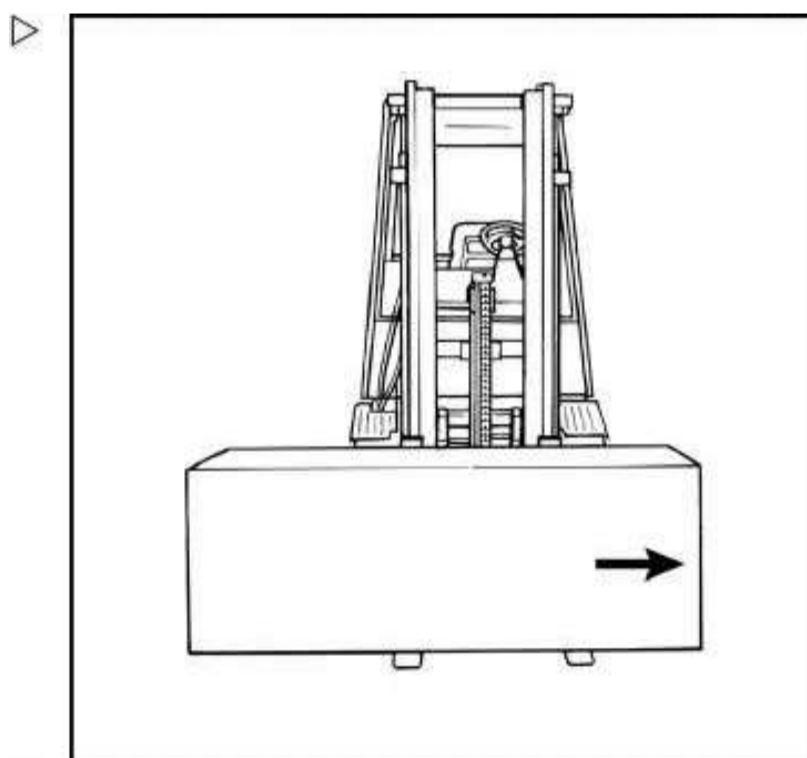
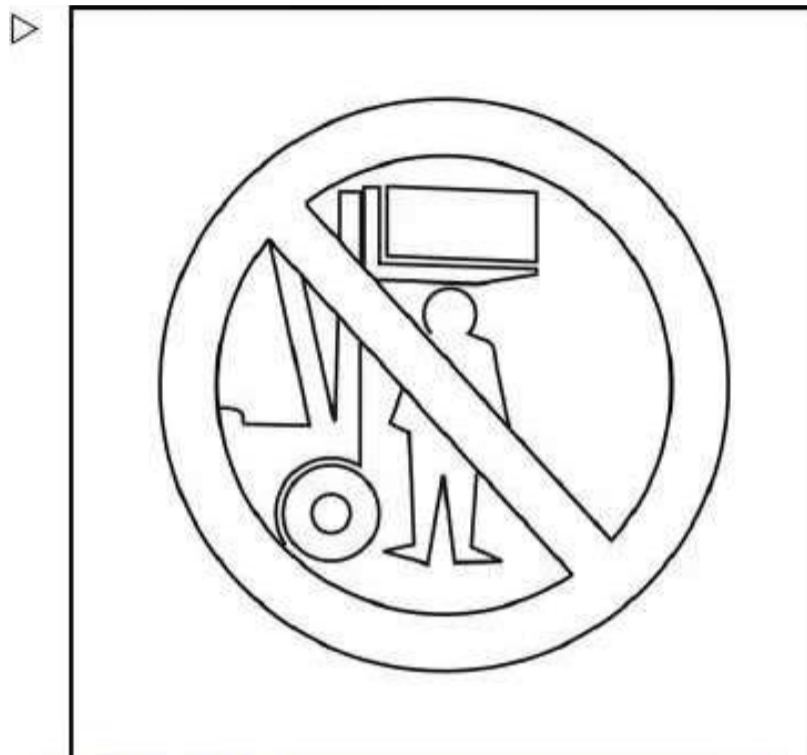

4 Operation

Tow coupling

Linde Material Handling



Unloading

- Carefully approach the shelf or goods stacking area.
- Lift the fork carriage to a suitable height.
- Place the lift mast in a vertical position.
- Carefully drive the forklift truck into the shelf.
- Slowly lower the goods until the fork arms are able to separate from the goods.
- Reverse the forklift truck.

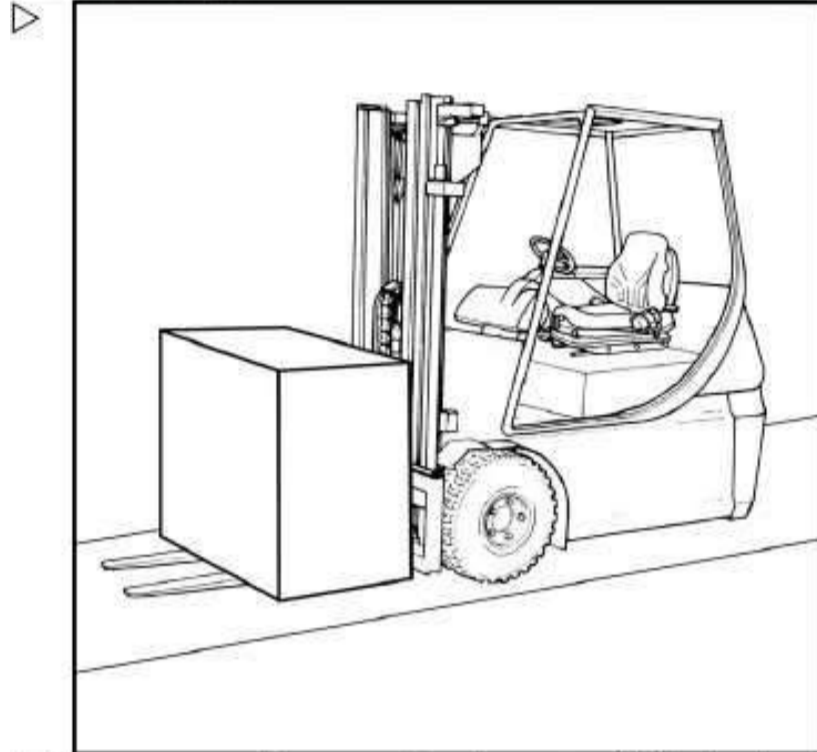

Before exiting the truck

- Unload the goods and lower the fork carriage.
- Tilt the lift mast forwards slightly. The fork arms must touch the ground.
- Pull the hand brake (2).
- Press the emergency disconnect button (3).
- Turn the switch key (1) anticlockwise, and then remove.
- Release the seat belt.

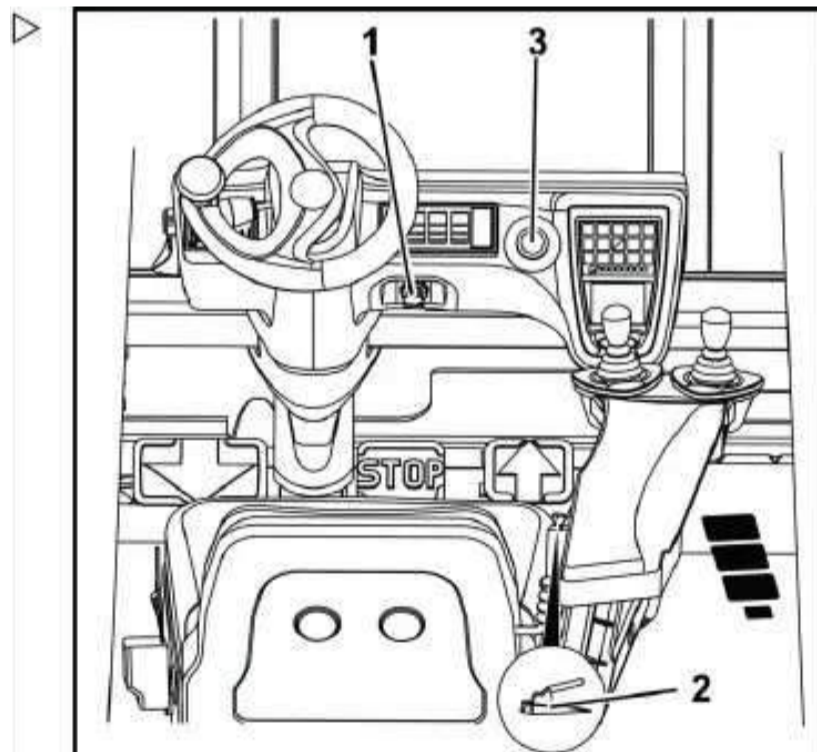

Tow coupling

Tow coupling

NOTE

The coupling can only be used for towing light vehicles inside the factory. (Please comply with correct accident prevention measures and VDI regulations)

- Insert the traction pin (1), turn 90degrees, and then remove.
- Place the tow bar into the connector tube.
- Push the tow pin against the spring, turn 90degrees and secure the safety lock.

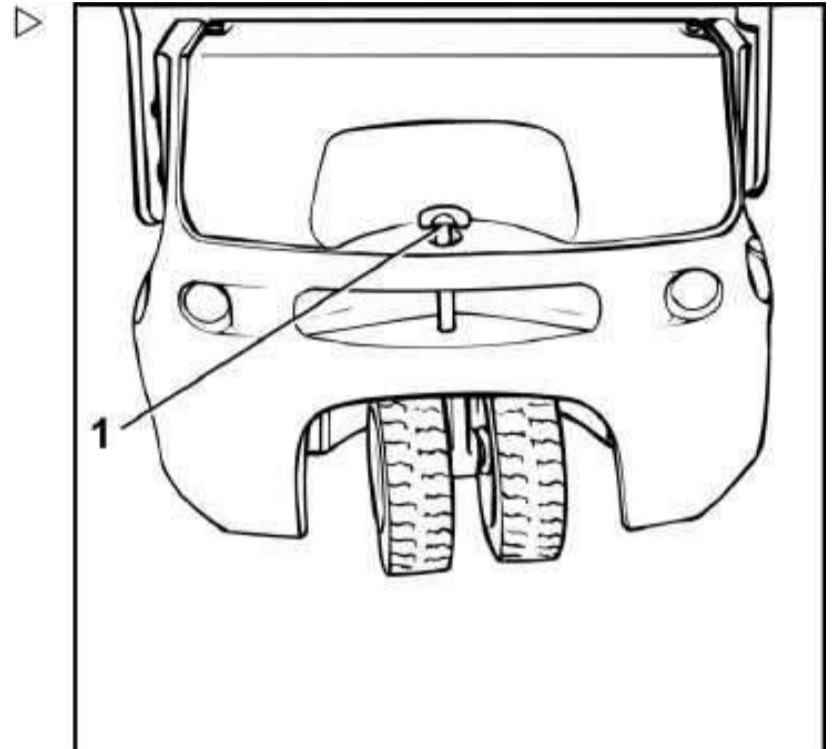

Truck transport

Towing regulations

Towing regulations

When the truck needs to be moved, a tow rope or rod can be attached to the tow pin. A tow rope can also be attached to the base of the lift mast.

▲ CAUTION

Braking can only be performed by the brake pedal or hand brake during towing.

Towing procedure

📄 NOTE

Power steering will be disabled after pressing the emergency isolator button.

4 Operation

Truck transport

Linde Material Handling



- Press the emergency isolator button.
- Lower the goods, but do not allow the fork arms to touch the ground.
- Remove the load.
- Secure the tow bar to the tow pin or rope on the base of the lift mast.
- Release the hand brake.
- The driver should operate the steering wheel during towing, and the brake when necessary.

Do not exceed the truck's maximum working speed when towing.

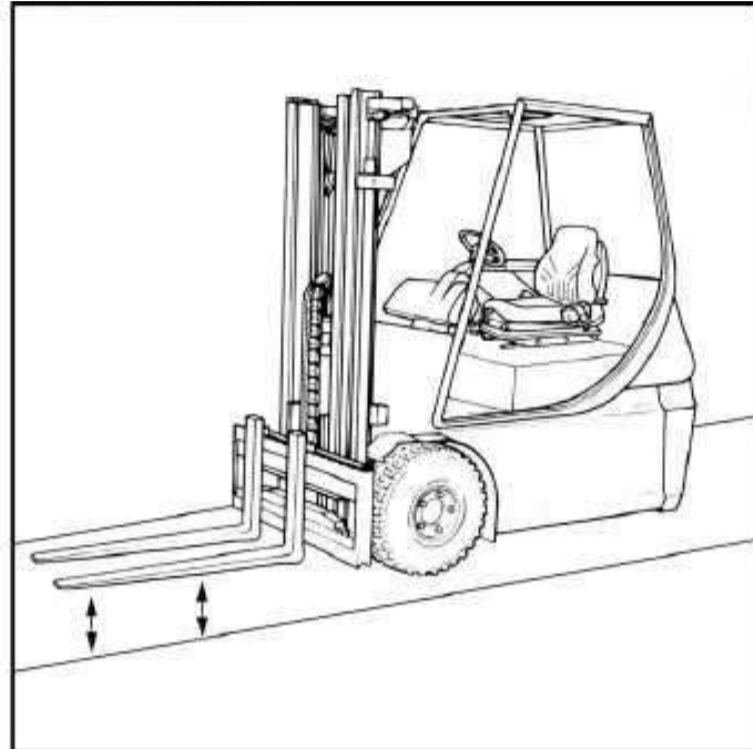

Carrying and lifting the forklift truck

Use a truck or flatbed trailer to carry the forklift truck

- Lower the lift mast.
- Exert the hand brake.
- Use wooden wedges to immobilise the truck.
- Secure the truck.

Use a hoist to lift the truck

▲ DANGER

Ensure that no one is in the working range of the hoist when using it to lift the truck!

Walking around under the lifted load is absolutely prohibited.

▲ CAUTION

Use lifting equipment and a hoist that has sufficient carrying capacity to lift the truck. For the truck weight (including the battery), see the factory nameplate.

The sling must be fastened at the designated lifting points when using the hoist. These lifting points are

not marked on the truck.

- Turn the tow pin (5) by 90degrees, and remove.
- Hang the sling (3) (minimum load 3000kilograms) on the tow pin.

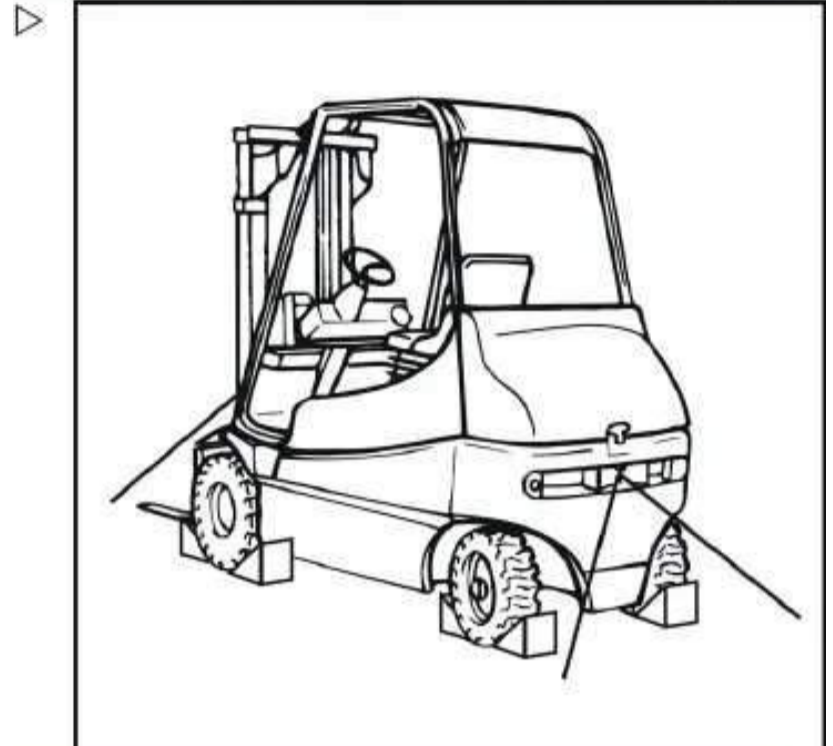

- Insert the tow pin, turn 90degrees, and lock.
- Fasten the sling (2) (minimum load 3000kilograms) onto the crossmember of the outer lift mast pillar.
- Hang all sling ends on the lifting hook (1) of the hoist.

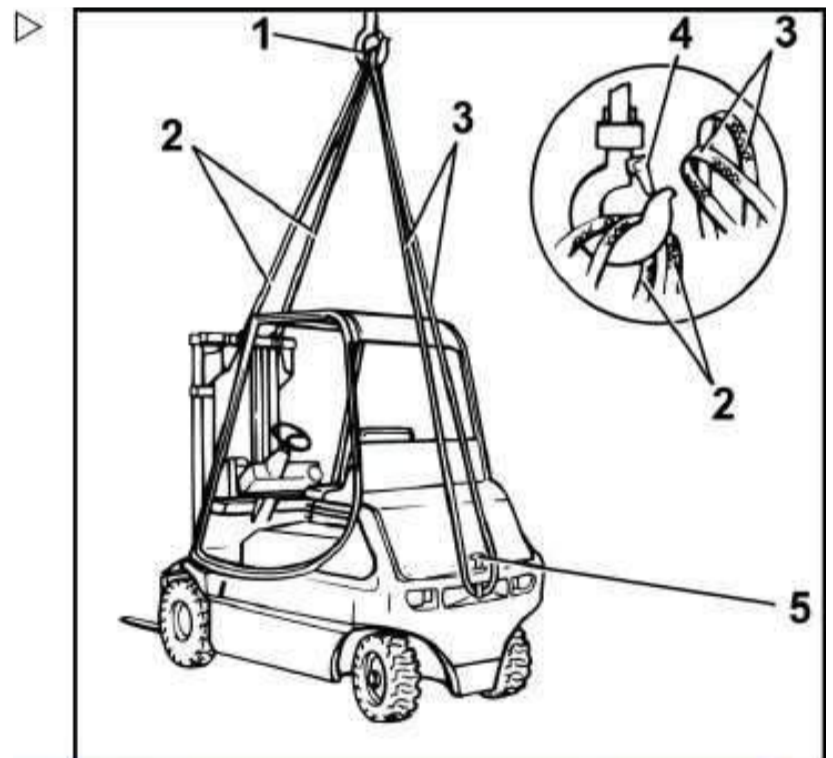

⚠ CAUTION

After hanging the sling on the lifting hook, the safety lock (4) must be fastened. The sling must not touch the overhead guard, rear cover or any other equipment installed on the overhead guard when the truck is being lifted.

Using a lifting eye to lift the truck

⚠ CAUTION

Use lifting equipment and a hoist with sufficient lifting capacity to lift the truck.

For the truck weight (including the battery), see the factory nameplate.

⚠ CAUTION

When using a hoist and lifting eye, you must prepare a suitable lifting frame (3) and vertical hanging chains (2 and 6) located above the lifting eye (1).

4 Operation

Linde Material Handling



Wheel change

- Fasten the lifting chain (6) (minimum load 3000kilograms) onto the counterweighted lifting eye (1) of the hoist.
- Fasten the lifting chain (2) (minimum load 3000kilograms) onto the lifting eye (1) of the hoist.

⚠ CAUTION

After hanging the lifting chains onto the lifting hook (4), the safety lock (5) must be fastened.

The lifting chains must not touch the overhead guard and other equipment installed on the overhead guard.

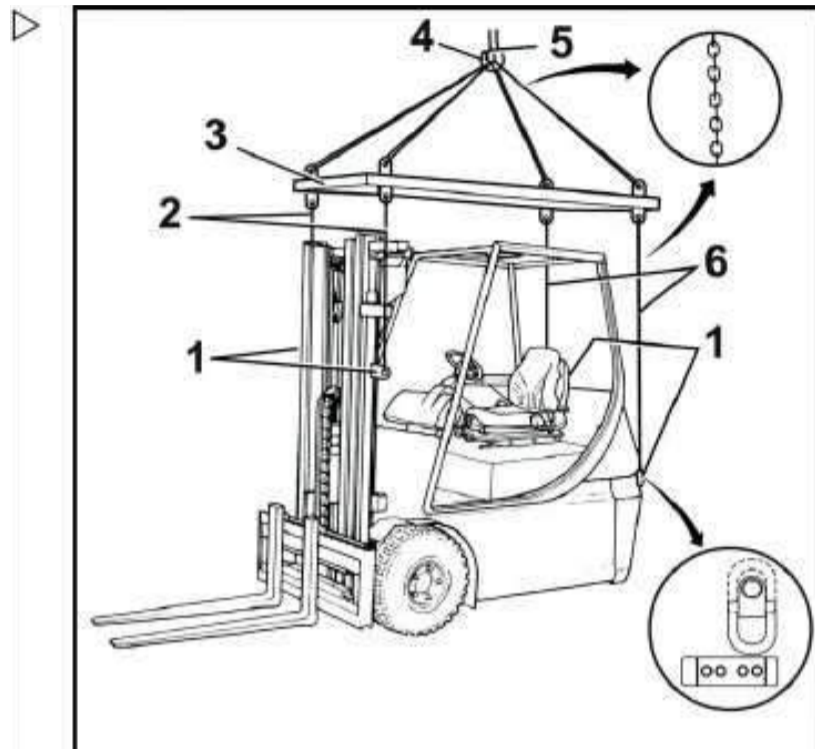

Wheel change

Wheel change

⚠ CAUTION

Use a jack with a sufficient lift weight. The minimum lift weight should be at least 3600kilograms.

⚠ CAUTION

A conductor belt must be installed on the forklift when anti-static tyres are being changed, as these tyres are non-conducting.

Please contact Linde dealers.

Placement of the jack when replacing the rear wheels

- Loosen the wheel fastenings.
- Only jack the forklift truck in the following places: For the E18C forklift truck, the jacking point is at the right or left side below the counterweight;
- The E18P/20P forklift truck should be jacked at the central point below the counterweight, until the wheels leave the ground.

⚠ CAUTION

The forklift truck can only be lifted from this position at the rear of the truck.

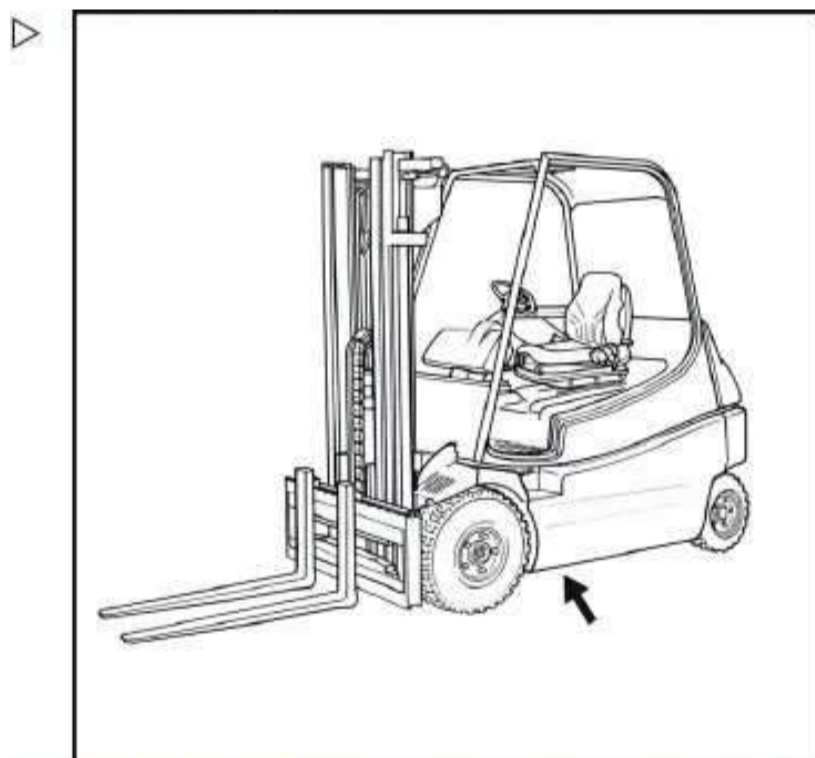

- Use wood pieces to cushion the truck. <http://www.forkliftpdfmanuals.com/>

- Remove the wheel fastenings and change the wheel.
- Replace the wheel fastenings and tighten by hand.
- Lower the truck.
- Use a 210Nm torque to tighten the wheel fastenings.

Placement of the jack when replacing the front wheels

- Loosen the wheel fastenings.
- Remove the traction pin (1).
- Remove the cover on either the right or left side of the front end of the forklift chassis.
- Insert the traction pin (1) into the hole.
- Place the jack below the traction pin and jack the forklift truck. The tip of the flat head of the traction pin should be supported against the jack plunger.

CAUTION

The forklift truck can only be lifted from this position at the front of the truck.

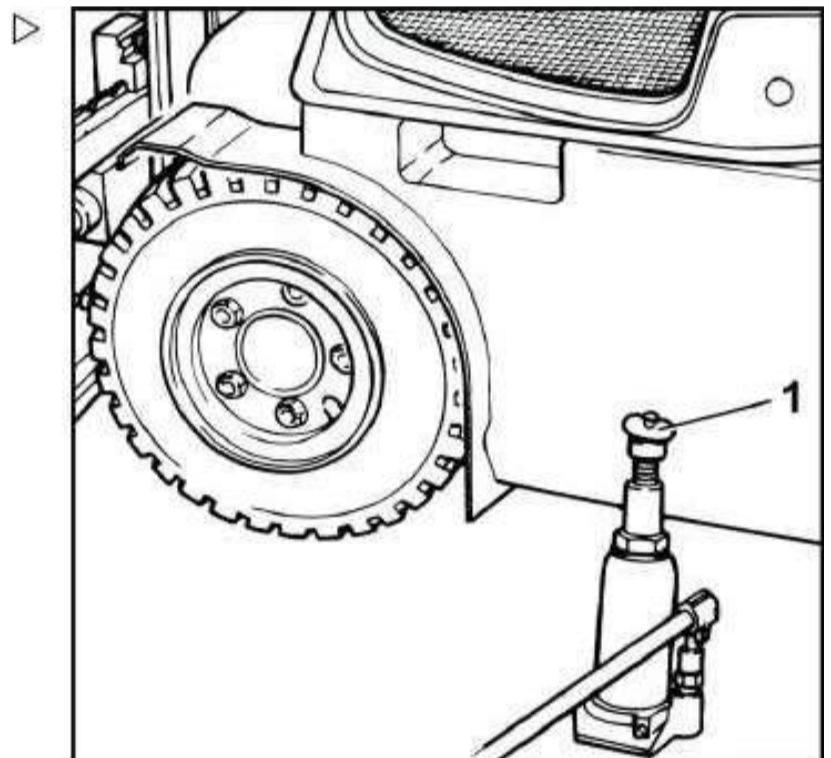

4 Operation

Linde Material Handling



Use in cold stores

Use in cold stores

Identification

Your forklift truck is equipped with specialised equipment for use in cold stores. It can be used within two operating ranges and is affixed with a cold store label.

The forklift truck's cold store equipment includes specialised oil suitable for use in cold stores (used in the hydraulic apparatus and gears).

Proper usage

Operating range 1: Permanent use in areas with a temperature of -5°C ; short-term use in areas with a temperature as low as -10°C . Park the truck outside the cold store.

Operating range 2: Follow the guidelines when using the forklift truck inside and outside at temperatures between -32°C and $+40^{\circ}\text{C}$. Park the truck outside the cold store. Use hydraulic oil as stipulated in the maintenance characteristics table.

Application

Changing from a cold indoor temperature to a hot outdoor temperature will cause condensation. Condensation water will freeze when the forklift truck returns to the cold store, obstructing the moving components of the stacker. This is why the specified length of stay for the forklift truck in the following two operating ranges must be strictly observed.

The temperature of the traction battery must not drop as low as the temperature of the cold store or it will stop working.

Before starting

⚠ CAUTION

Before using the forklift truck in the cold store, it must be dry and at operating temperature.

- Drive the forklift truck for approximately 5 minutes. Operate the brake several times



to ensure the operating safety of the forklift truck.

- Operate all lifting functions several times. Allow the oil temperature to reach operating temperature. This warm-up stage is essential.

Operating range 1

Permanent use in areas with a temperature of -5°C ; short-term use in areas with a temperature as low as -10°C . Park the truck outside the cold store.

Operating range 2

Use in internal temperatures as low as -32°C and external temperatures as high as $+25^{\circ}\text{C}$. Short-term use in temperatures of up to $+40^{\circ}\text{C}$ is also possible. The forklift truck must not leave the cold store for longer than 10 minutes, as this length of time is not sufficient for condensation to form. If the forklift truck remains outside the cold store for longer than 10 minutes, it must remain outside the cold store for long enough to allow the condensation to dissipate.

This usually requires at least 30 minutes.

DANGER

If condensation water freezes in the cold store, frozen components must not be de-iced by hand.

Parking

- The truck must be parked outside the cold store.

CAUTION

The battery must not be left in the cold store overnight when discharged or deactivated.

- Recharge the battery outside the cold store and use a spare battery.

4 Operation

Linde Material Handling



Truck storage

Truck storage

Taking the forklift truck out of operation

If the forklift truck is not to be used for over 2 months, place it in a very well ventilated, frostless, clean and dry room. Additionally, these steps below should be followed:

Steps to be taken before putting the forklift truck temporarily out of use

- Clean the forklift truck thoroughly.
- Lift and lower the fork carriage to its full extent and tilt the lift mast forwards and backwards several times. Repeat the same operation several times on attachments if they exist.
- Lower the fork carriage onto the support block to release the load on the chain.
- Check the hydraulic oil level and refill if necessary.
- Apply a thin coat of oil or grease to the surfaces of all naked components.
- Lubricate the forklift truck.
- Check the condition of the battery and the electrolyte level. Apply non-acidic grease to the terminal. (Should comply with manufacturer's instructions).
- Spray all the electrical contacts with the appropriate contact spray.

⚠ CAUTION

Erect and fix the forklift truck to prevent permanent tyre deformation.

NOTE

Do not cover the forklift truck with plastic film as it may gather water vapour.

NOTE

If the forklift truck is not in use for over 6 months, please contact your Linde dealer in order to take further measures.

Bringing the forklift truck back into use

- Clean the forklift truck thoroughly.
- Lubricate the forklift truck.
- Apply non-acidic grease to the battery terminal.
- Check the battery condition and electrolyte level.
- Check if the hydraulic oil contains any water and change the oil if necessary.
- Conduct all maintenance as required for first use.
- Using the forklift truck.

General Knowledge

Proper functioning of the forklift truck can only be maintained by carrying out periodic maintenance and checks according to the operating guidance and tips set out in the user guide. Checking and maintenance work may only be performed by technicians accredited by the Linde Corp. Ltd. This work can be performed by your dealer according to the Maintenance Contract.

If you wish to maintain and service the forklift truck yourself, we recommend that maintenance is carried out by the dealer's appointed technicians for at least the first three times. Your maintenance personnel should also be present in order to receive appropriate training.

During the maintenance process, please make sure that the forklift truck is stationary on flat ground and that it does not slide.

Lower the fork carriage and slowly tilt the lift mast forward until the truck is stationary. Apply the handbrake. Press the emergency off switch and remove the key. When working on a truck with a raised carriage or lift mast,

the carriage or lift mast must be secured to prevent it falling.

Ensure that the carriage and lift mast will not fall suddenly when raised.

When carrying out maintenance on the back of the truck, the lift mast must be secured to prevent backwards tilting.

Modifying or installing additional equipment on the forklift truck is prohibited without the agreement of the manufacturer.

CAUTION

Lost or damaged name plates and warning labels must be replaced. Refer to user manuals for position and part numbers.

A functional test and trial run should be performed after every maintenance check.

NOTE

If the forklift truck is used in an extreme environment (such as excessive heat, excessive cold or areas with high dust concentrations),

the time intervals given in the maintenance tables should be reduced accordingly.

CAUTION

Follow the manufacturer's safety regulations and disposal methods regarding oil, lubricating grease and cleaning fluids.

Maintenance intervals

NOTE

If the forklift truck is used in a designated environment, the time intervals in the maintenance table can be changed. The inspection and maintenance intervals depend on the operating and service conditions of the forklift truck. We recommend shortening the maintenance intervals for forklift trucks operating in harsh environments. If you have any questions, please contact a Linde dealer.

4 Operation

Linde Material Handling



Disposal of old trucks

Disposal of old trucks

The disposal of old trucks is regulated in directive 2000/53/EC from the European Parliament and Council.

We therefore recommend having this work carried out in an approved recycling plant. If you would like to carry out this work yourself, you must obtain approval from the relevant authorities as per articles 9, 10 and 11 of directive 75/442/EEC.

In addition, the following minimum requirements must be observed:

- The locations in which old trucks are stored before treatment must be areas suited to this task with impervious surfaces. These areas are also to be equipped with collection devices and separators for leaking fluids and degreasing cleaning materials
- The locations for treatment must be areas suited to this task with impervious surfaces. These areas are also to be equipped with collection devices and separators for leaking fluids and degreasing cleaning materials. Suitable storage areas must be

available for disassembled and partially oil-smearred parts, as well as for tyres including fire protection measures. Suitable storage tanks for fluids such as fuel, engine

oil, hydraulic oil, coolant and fluids from air conditioning systems must also be provided.

- In order to dispose of harmful substances from the old trucks, the batteries and LPG container must be removed. The following must also be removed, collected and stored separately: fuel, engine oil, coolant, hydraulic oil and fluids from air conditioning systems
- The following parts are to be collected separately and recycled: catalytic converters, metal components containing copper and aluminium, tyres, large plastic components (consoles, fluid containers) and glass

NOTE

The operating company is responsible for adherence to the directives as well as additional country-specific regulations.

5

Maintenance

5 Maintenance

Summary

Summary

Truck storage

If the forklift truck will not be used for more than 2 months, it should be parked in a well-

ventilated, frostless, clean and dry place, and the following measures should be taken:

Measures to be taken prior to truck storage

- Clean the truck thoroughly.
- Both raise and lower the fork carriage and tilt the lift mast forwards and backwards several times. If equipped with attachments, operate the attachments several times.
- Lower the fork onto a support platform so that the lift chain does not continue to experience stress.
- Check the hydraulic oil level, and fill up if necessary.
- Apply a thin layer of oil or grease to the surface of all unpainted parts.
- Lubricate the forklift truck.
- Check the condition and electrolyte level of the rechargeable battery. Apply a layer of non-acidic grease to the battery terminals. (Refer to the user manual from the battery manufacturer.)
- Apply a layer of suitable spray to all exposed wire connectors.

⚠ CAUTION

Jack up the forklift truck, so that the wheels leave the ground.

Avoid tyre deformation.

NOTE

Do not use plastic sheeting to cover the forklift truck because this will exacerbate condensation and aggregation.

NOTE

If the forklift truck will be out of use for a period of over 6 months, please consult the manufacturer for relevant information.

Resuming use of the forklift truck

- Clean the truck thoroughly.
- Lubricate the forklift truck.
- Apply a layer of non-acidic grease to the battery terminals.
- Check the battery condition and electrolyte level.
- Check the engine oil. If there is too much water, change the oil.
- Check the hydraulic oil. If there is too much water, change the hydraulic oil.
- Carry out routine maintenance on the forklift truck before use.
- Put the truck into operation.

General remarks

Proper functioning of the forklift truck can only be maintained by carrying out periodic maintenance and checks according to the guidance and tips set out in the user guide.

Checking and maintenance work may only be performed by technicians accredited by the Linde Corp. Ltd.

You can agree performance of this work on the basis of a maintenance agreement concluded with your authorised dealer.

If you want to carry out maintenance on the forklift truck yourself, we recommend that maintenance be carried out by technicians appointed by the dealer at least for the first three times. Your maintenance personnel should also be present, in order to receive appropriate training.

The forklift truck should be parked on a level surface, and the tyres fixed before starting any maintenance work.

Working on the lift mast or front section of the fork lift truck

The industrial truck must be switched off completely and the switch key must be removed.

Disconnect the battery connector plug.

When maintenance needs to be carried out under the lifted fork carriage and mast, measures must be taken to prevent the fork carriage or mast from accidentally falling.

When work needs to be carried out at the front end of the forklift truck, the mast should be secured to prevent backwards tilting.

Modifying or installing additional equipment on the forklift truck is prohibited without the agreement of the manufacturer.

All servicing work should be followed by a function check and a test run performed on the industrial truck.

⚠ WARNING

Any side doors attached could fall shut during maintenance and trap staff.

For this reason, both doors should be opened and secured in place during servicing.

⚠ CAUTION

The truck must always be properly labelled.

If the nameplates or affixed labels have parts missing or are damaged, they should be replaced with new ones. For locations and order numbers, please see the spare parts catalogue.



ENVIRONMENT NOTE

Please comply with regulations regarding the use or handling of fuel and lubricating oil.



NOTE

If the forklift truck is in an extreme environment (such as excessive heat, excessive cold or areas with high dust concentration), the time intervals given in the maintenance tables should be reduced accordingly.

Maintenance intervals

The inspection and maintenance intervals depend on the operating and application conditions of the industrial truck.

For heavy-duty conditions we recommend shorter intervals.

Please contact your authorised dealer.

Working on the lift mast or front section of the fork lift truck

⚠ DANGER

When working on the lift mast there is the risk of becoming trapped and/or accidental lowering of the lift mast.

The following safety measures must be taken before carrying out any maintenance work or adjustments to the lift mast and fork carriage!

These safety measures only apply to carrying out routine maintenance on the truck (testing and lubricating).

Additional safety measures must be taken when carrying out maintenance (such as replacing the lift chains or lift cylinder). Please contact your authorised Linde dealer.

5 Maintenance

Linde Material Handling



Working on the lift mast or front section of the fork lift truck

Securing the mast to prevent backward tilting ▷

In order to prevent the lift mast accidentally tilting backwards, a piece of hard wood (120 x 120 x 800 mm) must be placed between the lift mast and body of the truck(1).

The lift mast must be secured from tilting backwards unintentionally (see arrow).

- Tilt the lift mast right back.
- Press the emergency off switch.
- Pull the switch key out of the key switch.
- Disconnect the battery male connector.

The truck must be switched off completely.

- Apply the parking brake.

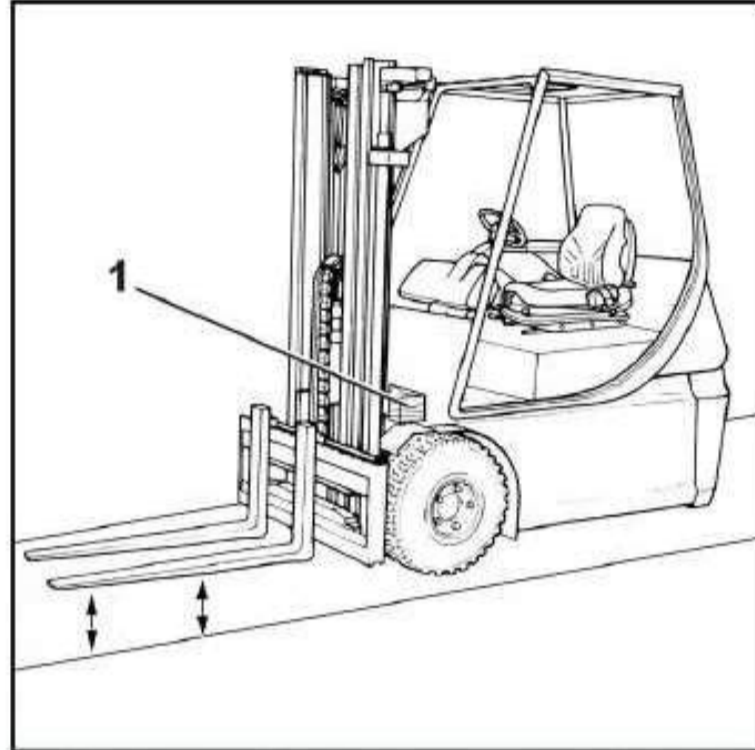

Ordinary duplex mast

When the internal lift mast is rising, the chain wheels will turn and the fork carriage will rise with the lift mast at a ratio of 2:1.

Securing the ordinary duplex mast during lifting ▷

⚠ DANGER

Check chain load!

Select a safety chain with sufficient load bearing capacity for the lift mast. Take the maximum lift height into account.

- Raise the mast.
- Secure the upper beam of the outer lift mast(1) and the inner lift mast beam(2) together with chains.
- Watch out for the hose lines on the cross beam of the outer mast.
- Lower the mast until it is supported by the chains.

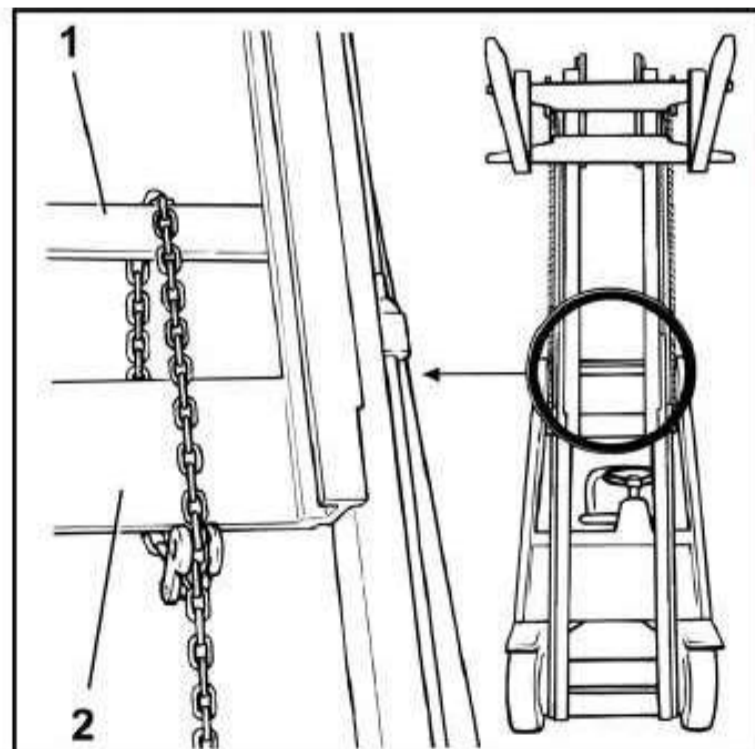

Full free lift duplex mast

NOTE

The advantage of this kind of mast is that its free lift height can be fully utilised even when working in very low spaces (such as basements or inside vehicles or ships).

Function: The fork carriage is lifted to its free lift height by the central lift cylinder via the guiding chains.

Here it moves twice as fast as the centre cylinder.

The inner mast and fork carriage are then lifted together by the duplex outer cylinder.

The central cylinder is installed onto the liftable inner mast.

Securing the full free lift duplex mast during lifting

DANGER

Check chain load!

Select a safety chain with sufficient load bearing capacity for the lift mast. Take the maximum lift height into account.

- Lift the mast.
- Secure the upper beam of the outer lift mast(1) and the inner lift mast beam(2) together with chains.
- Watch out for the hose lines on the cross beam of the outer mast.
- Lower the mast until it is supported by the chains.
- Completely lower the fork carriage.

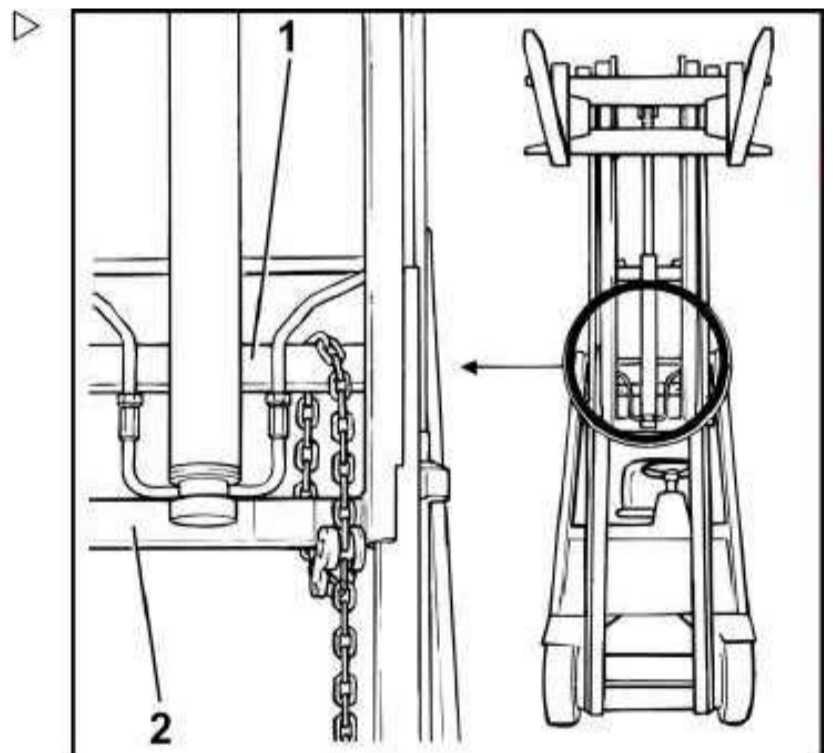

Triple mast

Function: The fork carriage is lifted to its free lift height by the central lift cylinder via the guiding chains.

The inner mast is then lifted by the two duplex outer cylinders.

5 Maintenance

Inspection and maintenance parameters

The lifting speed of the inner mast is twice that of the cylinders due to the function of the guidance chains.

The central lift cylinder is fixed onto the liftable inner mast.

Securing the triple mast during lifting

▲ DANGER

Check chain load!

Select a safety chain with sufficient load bearing capacity for the lift mast. Take the maximum lift height into account.

- Raise the mast.
- Secure the outer lift mast beam(1) and the inner lift mast beam(2) together with chains.
- Watch out for the hose lines on the cross beam of the outer mast.
- Lower the mast until it is supported by the chains.
- Completely lower the fork carriage.

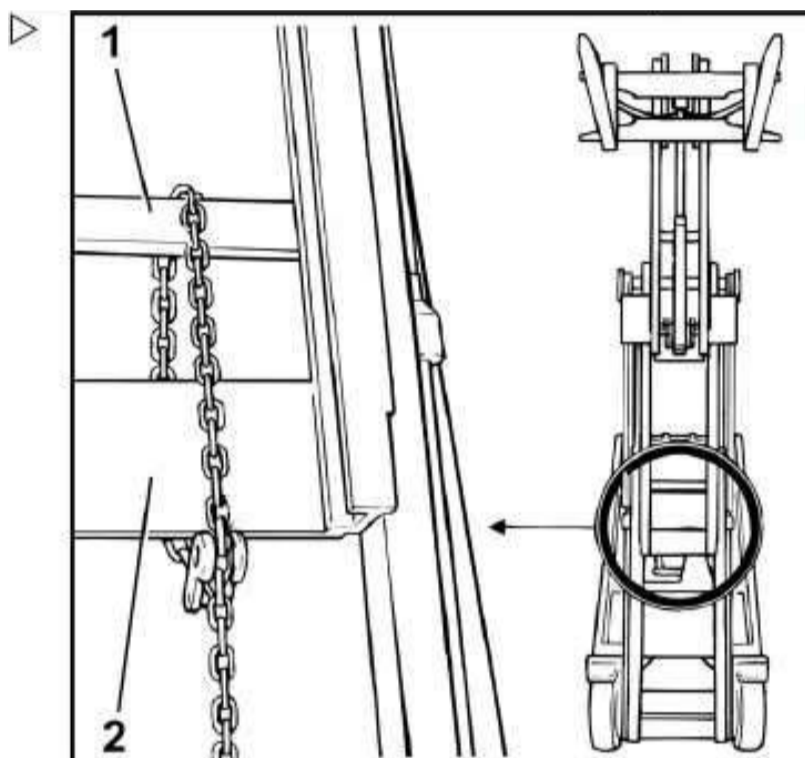

Inspection and maintenance parameters

No	Unit	Devices/consumables	Filling quantity / Set values
1	battery	Distilled water Acid-free grease	As required As required
2	Electric motors: Traction motor Hydraulic motor	Cleaning agents for electrical equipment	
3	Right and left-hand traction motor Oil pump motor Accelerator Hydraulic controller Horn Fan Charge/Discharge circuit Control circuit	Fuse Fuse Fuse Fuse Fuse Fuse Fuse	1 x 355 A 1 x 300 A 1 x 5A 1 x 5A 1 x 10 A 1 x 5 A 1 x 10 A 1x15A; 1X10A; 1X5A

No	Unit	Devices/consumables	Filling quantity / Set values
4	Hydraulic system	Filter insert for suction filter Filter insert for pressure filter	15 µm 6 µm
	Hydraulic system Standard, duplex mast — all lift heights Triple mast - maximum lift height of up to 5620 mm Triple mast - lift height of 5770 mm or higher	Hydraulic oil	8.9 litres 11.8 litres
5	Wheels	Drive wheel, rear wheel	Torque value 210 Nm
6	Gearbox	Gearbox oil	Oil change: 0.6 litres
7	Steering axle	Lubricating grease	As required
8	Lift mast tilt cylinder pin shaft	Lubricating grease	As required
9	Lift mast and chain guide	Linde chain spray	As required
10	Brake system Brake discs in the drive axle	Brake fluid Brake fluid	0.2litres

Recommended lubricants

Hydraulic oil

⚠ CAUTION

Damage to the hydraulic system due to unapproved hydraulic oil.

Only use approved hydraulic oil. Only the following

types of hydraulic oil have been approved by the manufacturer. Do not mix hydraulic oils. Please contact your authorised dealer if you have any questions. Approval for any suggestions given by oil company representatives must also be sought from the authorised dealer.

Standard (average constant oil temperature 40-60°C)

Under normal loads, we recommend the use of:

Hydraulic oil ISO-L-HM 46, in compliance with ISO 6743-4;
or hydraulic oil HLP ISO VG46, in compliance with DIN51524 T.2Standard (factory filling).

Heavy duty (average constant oil temperature above 60°C)

Hydraulic oil ISO-L-HM 68, in compliance with ISO 6743-4;
or hydraulic oil HLP ISO VG68, in compliance with DIN51524 T.2Standards,

Light duty (average constant oil temperature below 50°C)

Hydraulic oil ISO-L-HM 32, in compliance with ISO 6743-4;
or hydraulic oil HLP ISO VG 32 , in compliance with DIN51524 T.2 Standards,

Variable load situations

NOTE

This type of hydraulic oil has a very high viscosity (multi-purpose hydraulic oil).

5 Maintenance

Linde Material Handling



Recommended lubricants

ISO-L-HV 46 can be used in all of the above operating situations in compliance with ISO 6743-4;
or hydraulic oil HVLP ISO VG 46 in compliance with DIN 51524 T.3 standards can be used as a substitute.

Bio-hydraulic oil

Aral Forbex® SE 46 highly biodegradable hydraulic oil

⚠ CAUTION

Damage to the hydraulic system due to mixing bio-hydraulic oil with mineral oil.

Only use approved pure bio-hydraulic oil.

📄 NOTE

The oils recommended above are for reference only.

Please contact your Linde dealer if you have any questions.

Your Linde dealer should also be contacted before using any oils recommended by the oil manufacturer.

The fork lift truck manufacturer only consents to the use of the above oils. Expensive damage may result if other hydraulic oils are used or hydraulic oils are mixed.

Gearbox oil

Gearbox oil SAE 80W - 90 API GL5 ,
or SAE 85W - 90 API GL4 (in compliance with DIN 51512 standards).

🗑 ENVIRONMENT NOTE

Used oil should be far away from children before being discarded according to regulations. Do not allow engine oil to permeate into the main drainage channel or the ground. Ideally,

gearbox oil should be changed by an authorized dealer due to their expert knowledge and experience in handling problems with disposal.

Linde lithium-saponified lubricating grease KPF2K (taking DIN 51825 as the standard)
Linde spare part no., see spare parts catalogue

Linde heavy-duty grease, lithium-saponified with EP active ingredients and MOS₂. KPF2N-20 (taking DIN 51825 as the standard)

Linde spare part no., see spare parts catalogue

📄 NOTE

Mixing with soap-based lubricating grease types other than lithium-saponified is not permitted.

Battery grease

Acid-free lubricating grease (battery grease)

Chain spray for chains

Linde standard chain spray
Linde spare part no., see spare parts catalogue

Brake fluid

DOT 3 brake fluid to SAE J1703 (such as Ate model S)
or DOT 4 brake fluid to SAE J1704 or FMVSS 116 (such as Ate model SL)
Drive axle brake fluid grade is "Shell DONAX TX" (= > I 02/2013) / "Shell Spirax S4 ATF HDX" (03/2013 =>)



1000 hour maintenance plan

1000 hour maintenance plan

At operating hours									Carried out	
1000		2000		4000		5000		7000		
8000		10000		11000		13000		14000		
16000		17000		19000		20000				
Maintenance plan information										
Maintenance intervals are set according to the type of oil used, driving habits and operating requirements, but maintenance should be carried out according to this maintenance plan at least every 1 , 2 , 4 , 5 , 7 , 8 , 10 , 11 , 13 , 14 , and 16 working years. Please refer to the oil use recommendations.										
Before starting maintenance work:										
Clean the fork lift truck if necessary										
Check the time and date settings on the display unit; adjust if necessary.										
Check for error codes on diagnostic software and delete.										
Calibrate the potentiometer and joysticks.										
Set a reminder for the next maintenance check on diagnostic software.										
Reduction gearbox										
Check whether the speed reduction gearbox is leaking										
Check the drive axle and reduction gearbox fastenings										
Clean both sides of the traction motor, the power steering and working hydraulic pump motor										
Frame and installation										
Chassis, tilt cylinders and steering axle: Check fastening.										
Check the counterweight, motors, chassis, speed reduction gearbox, overhead guard and steering axle fastenings.										
Lubricate the overhead guard pin shaft.										
Check and lubricate the other pins and swivel points.										
Check the condition of the antistatic belt.										
Chassis frame										
Check for correct operation of the parking brake and readjust if necessary.										
(As required) Check wheel fastenings and tighten if necessary (after each maintenance or repair, at the latest after 100 hours).										
Check the brake system										
(As required) Wheel change										
Check the release of the multi-disc brake for the towing procedure: press the brake lever at the brake valve several times.										

5 Maintenance

Linde Material Handling



1000 hour maintenance plan

At operating hours										Carried out	
1000		2000		4000		5000		7000			
8000		10000		11000		13000		14000			
16000		17000		19000		20000				✓	*
Check/lubricate the compact steering axle.											
Check/lubricate the movable steering axle.											
Operating devices											
Checking the joystick pad											
Checking and lubricating the pedal mechanisms, control linkage mechanisms and the overhead guard locking devices.											
Check the horn for correct function.											
Electrics											
Check the fastenings of the cables and connectors connecting the power module and the motor.											
Check the condition and tightness of the electrical cables, electrical connections and plug connectors											
Battery: check the charge status, fluid level and proportion.											
Check the fans for correct operation.											
(As required) Clean the power modules of the traction and lift control, the fans and the heat sink with compressed air.											
Clean the contactor mounting board with compressed air.											
Inspect the contactor contacts, and replace if necessary											
Hydraulics											
Check the hydraulic oil level.											
Check the leak resistance of the working and steering hydraulic systems.											
Check that the breather filter on the hydraulic oil tank is working normally.											
Check the control unit for correct function.											
Replace the pressure and suction filters.											
Load lift system											
Check the condition, tightness and function of the lift mast, lift chains and stop block.											
Adjust the length of the lift chains, and lubricate using chain spray.											
Check the truck's releasing and locking equipment.											
Check the tilt cylinder bearing (particularly for any abnormal sounds when tilting forward or backward) for wear, and clean.											
Special equipment											



3000 hour maintenance plan

At operating hours									Carried out		
1000		2000		4000		5000		7000			
8000		10000		11000		13000		14000			
16000		17000		19000		20000				✓	*
Check that the side moving forks are operating normally; clean, lubricate and check their fastenings.											
Check the pre-tightening status of the double hose in trucks equipped with attachments.											
Subsequent tasks											
Carry out a functional test and test drive.											
Attach the maintenance sticker.											

3000 hour maintenance plan

At operating hours									Carried out		
3000		6000		9000		12000		15000			
18000										✓	*
Maintenance plan information											
Maintenance intervals are set according to the type of oil used, driving habits and operating requirements, but maintenance should be carried out according to this maintenance plan at least every 3, 9, and 15 working years. Please refer to the oil use recommendations.											
Before starting maintenance work:											
Clean the fork lift truck if necessary											
Check the time and date settings on the display unit; adjust if necessary.											
Check for error codes on the diagnostic software and delete.											
Calibrate the potentiometer and joysticks.											
Set a reminder for the next maintenance check on diagnostic software.											
Reduction gearbox											
Check whether the speed reduction gearbox is leaking											
Check the drive axle and reduction gearbox fastenings											
Clean both sides of the traction motor, the power steering and working hydraulic pump motor											
Drive axle: Check the side stops and adjust as necessary.											
Check the condition of the axle bearings.											



5 Maintenance

3000 hour maintenance plan

At operating hours										Carried out	
3000		6000		9000		12000		15000		✓	*
18000											
Changing the gearbox oil in the speed reduction gearbox											
Frame and installation											
Check the fastenings of the tilt cylinders at the lift mast.											
Check the counterweight, motors, chassis, speed reduction gearbox, overhead guard and steering axle fastenings.											
Lubricate the overhead guard pin shaft.											
Check and lubricate the other pins and swivel points.											
Check the condition of the antistatic belts (only for trucks fitted with super clean tyres).											
Chassis frame											
Check for correct operation of the parking brake and readjust if necessary.											
Check the brake system											
(As required) Check the wheel fastenings and tighten if necessary (after each maintenance or repair, at the latest after 100 hours).											
(As required) Wheel change											
Check the release of the multi-disc brake for the towing procedure: press the brake lever at the brake valve several times.											
Check/lubricate the compact steering axle.											
Check/lubricate the movable steering axle.											
Replacing the brake fluid											
Operating devices											
Checking the joystick pad											
Checking and lubricating the pedal mechanisms, control linkage mechanisms and the overhead guard locking devices.											
Check the horn for correct function.											
Electrical system											
Check the fastenings of the cables and connectors connecting the power module and the motor.											
Check the condition and tightness of the electrical cables, electrical connections and plug connectors											
Battery: check the charge status, fluid level and proportion.											
Check the fans for correct operation.											
(As required) Clean the power modules of the traction and lift control, the fans and the heat sink with compressed air. https://www.forkliftpdfmanuals.com/											

	Maintenance 5 3000 hour maintenance plan
---	--

At operating hours										Carried out	
3000		6000		9000		12000		15000			
18000										✓	✗
Clean the contactor mounting board with compressed air.											
Inspect the contactor contacts, and replace if necessary											
Hydraulic system											
Check the hydraulic oil level.											
Check the leak resistance of the working and steering hydraulic systems.											
Check the control unit for correct function.											
Replace the air, pressure and suction filters.											
Replace the hydraulic oil (if it is Bio hydraulic oil, the Aral Forbex SE46 is 6000 operating hours)											
Load lift system											
Check the condition, tightness and function of the lift mast, lift chains and stop block.											
Adjust the length of the lift chains, and lubricate using chain spray.											
Check the truck's releasing and locking equipment.											
Check the tilt cylinder bearing (particularly for any abnormal sounds when tilting forward or backward) for wear, and clean.											
Special equipment											
Check that the side moving forks are operating normally; clean, lubricate and check their fastenings.											
Check the pre-tightening status of the double hose in trucks equipped with attachments.											
Subsequent tasks											
Carry out a functional test and test drive.											
Attach the maintenance sticker.											

5 Maintenance

Linde Material Handling



Reduction gearbox

Reduction gearbox

Checking the wheel gear oil level

- Drive the truck until the oil level plug (1) is in a flat position (in the "9 o'clock" position) and the filling plug (2) is at the top.
- Apply the parking brake and switch off the truck.
- Clean the areas surrounding the oil level plug (1).
- Unscrew the oil level plug (1).

The oil level must reach the lower edge of the oil level plug hole. Please fill up with gear lubricating oil if necessary.

- Screw the oil level plug (1) back in, and tighten to 20Nm.

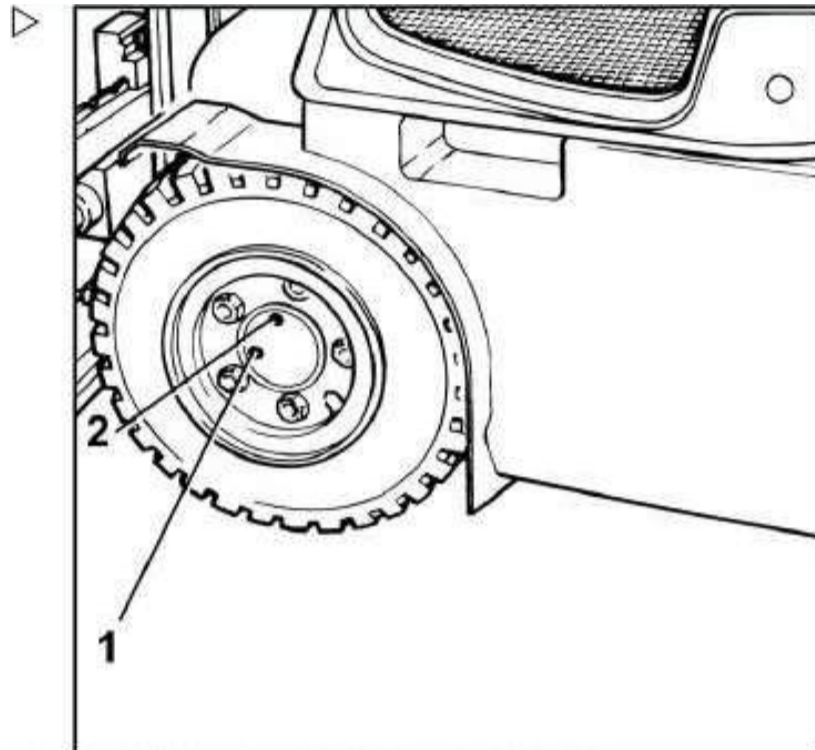

Checking whether the speed reduction gearbox is leaking

- Jack the truck at the front on the right or left side.
- Use wooden blocks to secure the truck.
- Check the fuelling ports on both sides of the speed reduction gearbox and the leak resistance of the oil drain plug and housing cover.
- If there is leakage, please contact your Linde dealer.

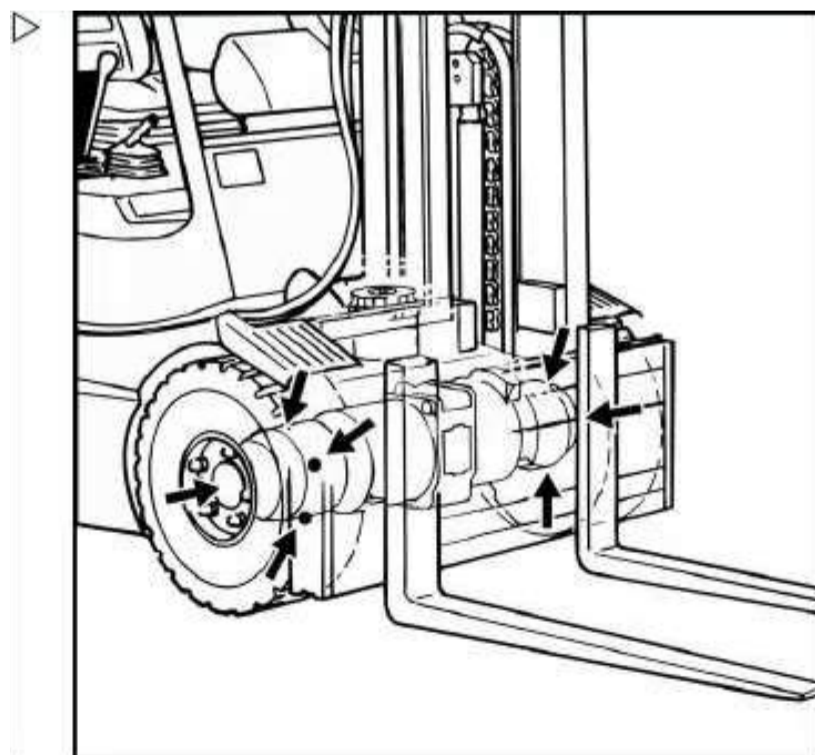

Cleaning both sides of the traction motor, the power steering and working hydraulic pump motor

- Place the lift mast in a vertical position.
- Lift and secure the fork carriage to prevent accidental falling.
- Press the emergency disconnect button.
- Lift the overhead guard into the 2nd lock position.

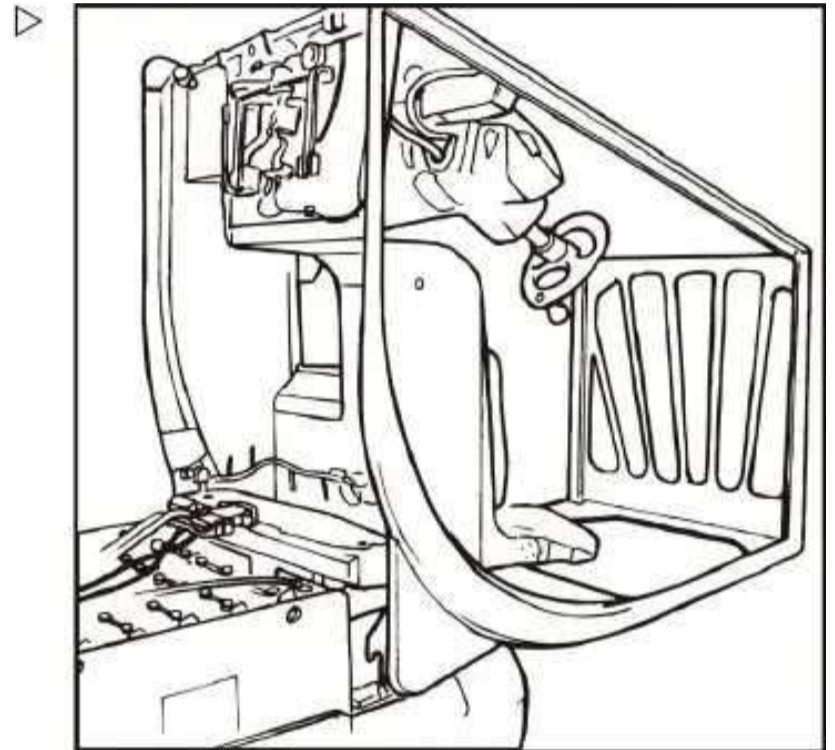

- Use compressed air to clean the traction motor, the power steering and working hydraulic pump motor.

i NOTE

The electrical system and wire terminals should be protected from moisture damage. Water must not be allowed to seep into the motor. If the motor gets damp, the truck should be operated (allowing the motor to dry on its own from the heat produced) or the motor should be blow dried using hot air or an air gun etc., to prevent corrosion.

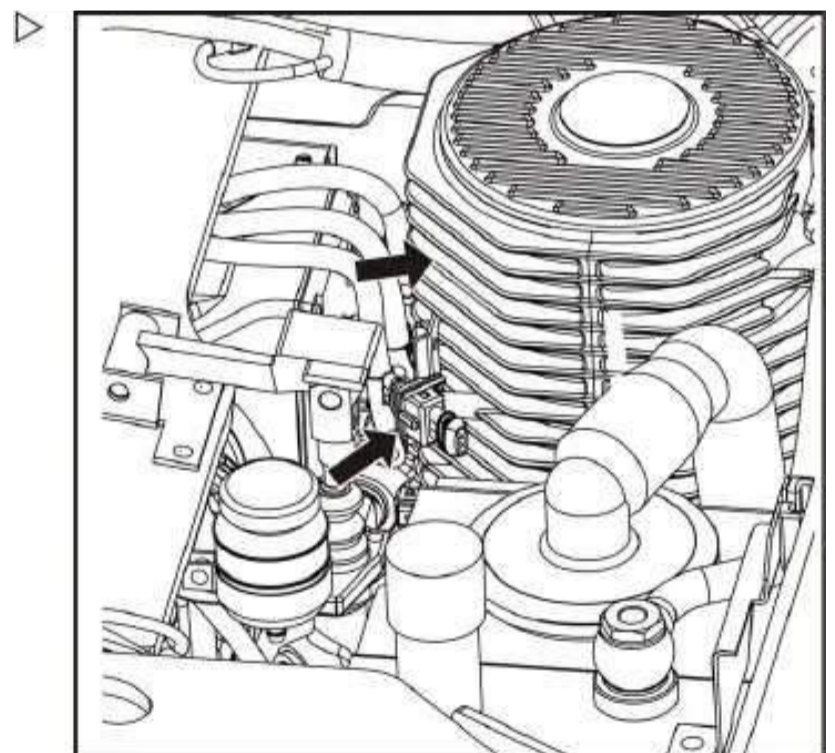

Replacing the gear oil in the speed reduction gearbox

Replacing the gear oil (without disassembling the wheels)

♻️ ENVIRONMENT NOTE

Follow the regulations for the safe handling of oil and lubricating grease.

5 Maintenance

Linde Material Handling



Reduction gearbox

- Operate the truck until the speed reduction gearbox is slightly warm.

NOTE

The following 2 methods can be used to replace the gearbox oil.

- Operate the truck until the filling plug (2) is at the top, and then stop the truck. ▷
- Clean the oil level plug (1), the fill plug (2) and the oil drain plug (3) and surrounding areas.
- Remove the oil level plug and the fill plug.
- Place a container under the oil drain plug (3).
- Remove the magnetic oil drain plug (3) and completely drain the gear oil.
- Clean the magnet on the oil drain plug (3).
- Reinstall and tighten the magnetic oil drain plug (3).

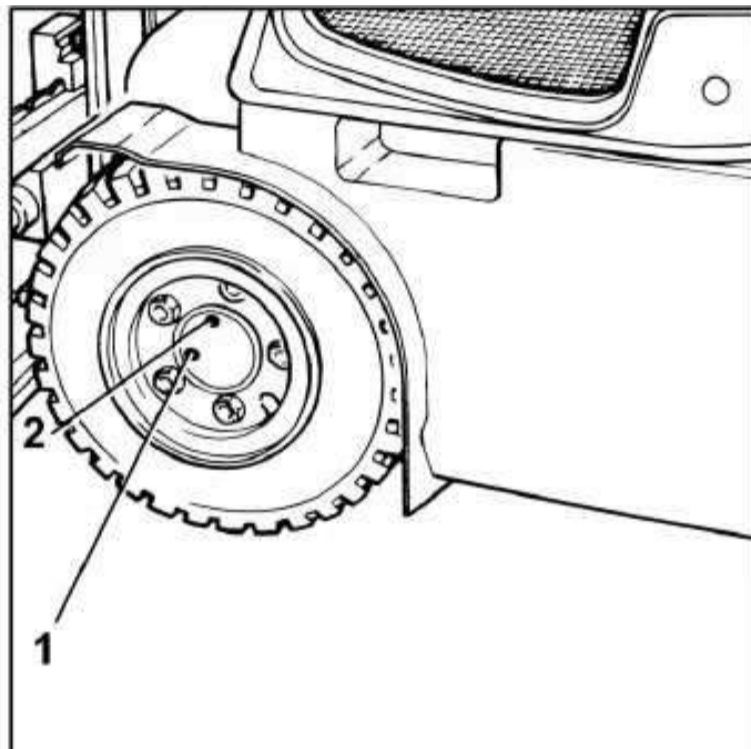

Oil drain plug (3) torque: 20Nm

- Pour approximately 400cc of gear oil into the speed reduction gearbox from the filling port, until the oil overflows from the oil level port (1).
- Tighten the oil level port (1) and the filling plug (2).

Torque: 20Nm

- Replace the gear oil in the speed reduction gearbox on the other side.

Replacing the gear oil (with disassembling the wheels)

NOTE

Follow the regulations for the safe handling of oil and lubricating grease.

- Operate the truck until the speed reduction gearbox is slightly warm.
- Drive the truck until the oil level plug (1) is in a horizontal position.
- Jack the truck on either the right or left side, and secure the wheels with wooden blocks.
- Take the wheels off (refer to Changing a wheel).
- Remove the 2 wheels and place them flat in order to drain the gear oil completely.
- Clean the oil level plug (1), the oil drain plug (3) and the fill plug (4) and surrounding areas.
- Place a container under the oil drain plug (3).
- Remove the oil level plug (1), the oil drain plug (3) and the fill plug (4). Completely drain the gear oil.
- Clean the magnet on the oil drain plug (3).
- Reinstall and tighten the magnetic oil drain plug (3).

Oil drain plug (3) torque: 20Nm

- Pour approximately 400cc of gear oil into the speed reduction gearbox from the filling port until the oil overflows from the oil level port (1).
- Tighten the oil level port (1) and the filling plug (2).

Filling plug torque (4): 70Nm

Oil level plug torque: 20Nm

- Replace the gear oil in the speed reduction gearbox on the other side.
- Fit the wheels and lower the truck.

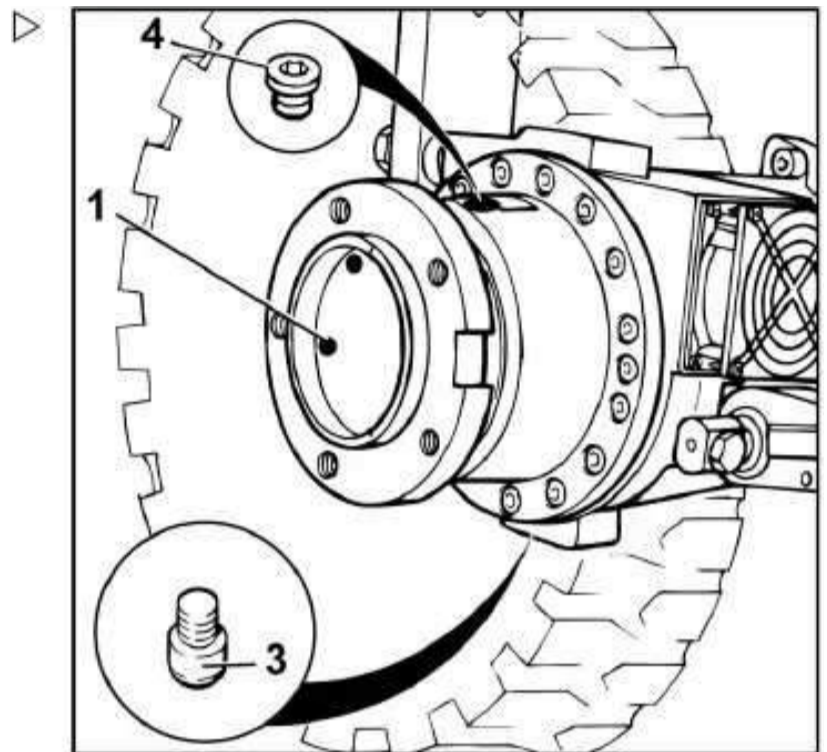

5 Maintenance

Linde Material Handling



Frame and installation

Frame and installation

Checking the counterweight, motors, chassis, speed reduction gearbox, overhead guard and steering axle fastenings

- Check the tightness and wear of the motor drive assembly, power steering, working hydraulic oil pump, motor, counterweight, chassis, speed reduction gearbox, overhead guard and the steering axle.
- Tighten loose nuts and screws.
- Replace damaged parts.
- Respray if necessary.

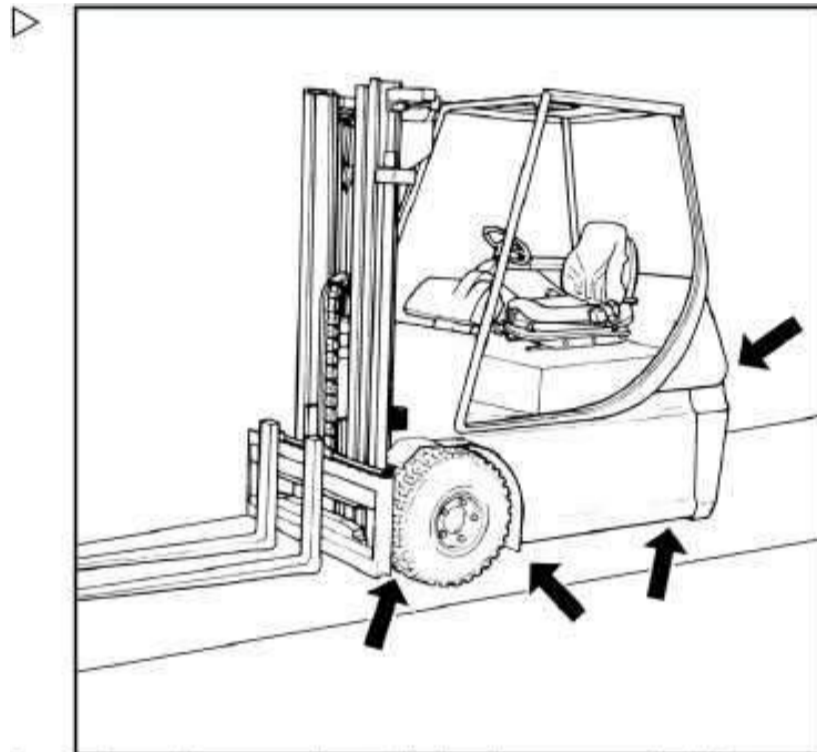

Lubricating the overhead guard pin shaft

NOTE

Use lubricating grease.

- Open the electrical system hood.
- Lubricate the injection nozzles on both sides of the pin shaft (1).
- Lubricate with a grease gun until the fresh lubricating grease overflows from the pin shaft.
- Close the electrical system hood.

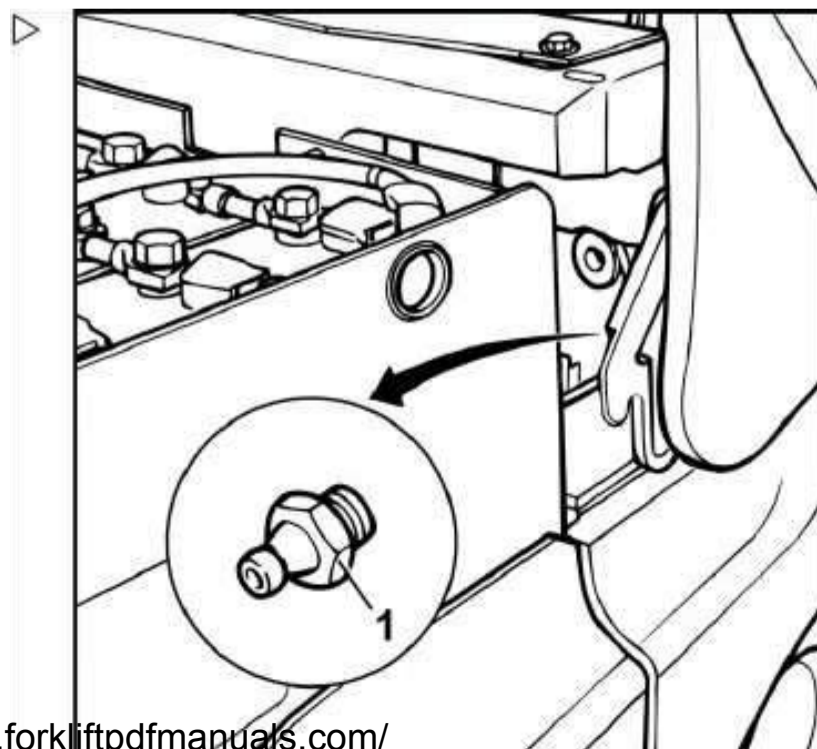

Checking and lubricating other pins and swivel points

Check and lubricate the pins and swivel points for the following components:

- Seat guide rail.
- Windscreen wiper-rinser system*
- Driver cab door locks and hinges*

*Optional part

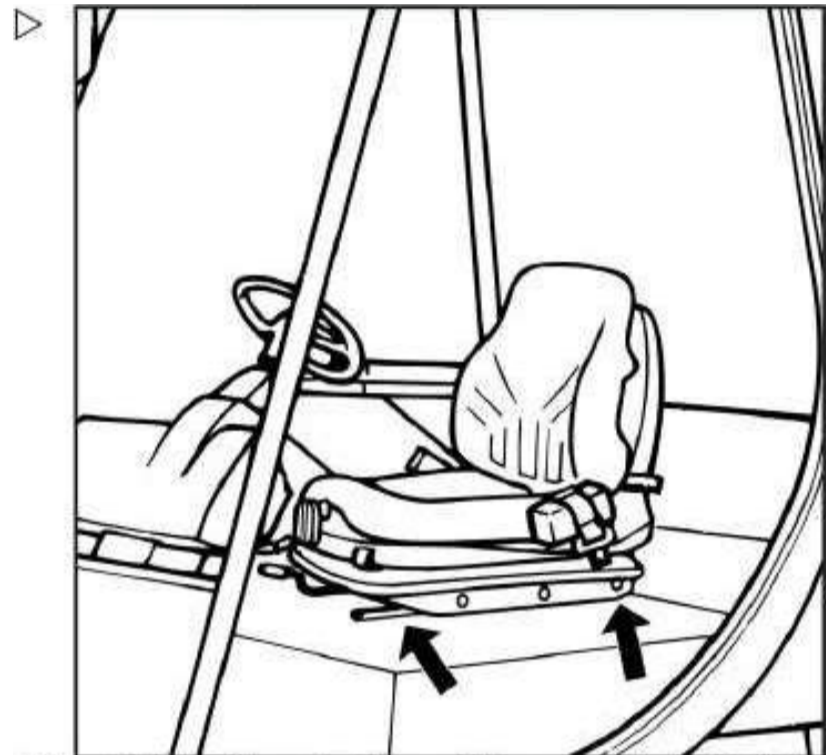

Checking the status of the anti-static belts* (only for trucks fitted with super clean tyres)

- Check whether the conductive strips located under the chassis are tightly secured or worn.
- Replace damaged conductive strips.

NOTE

The conductive strips must be in constant contact with the ground.

*Optional part

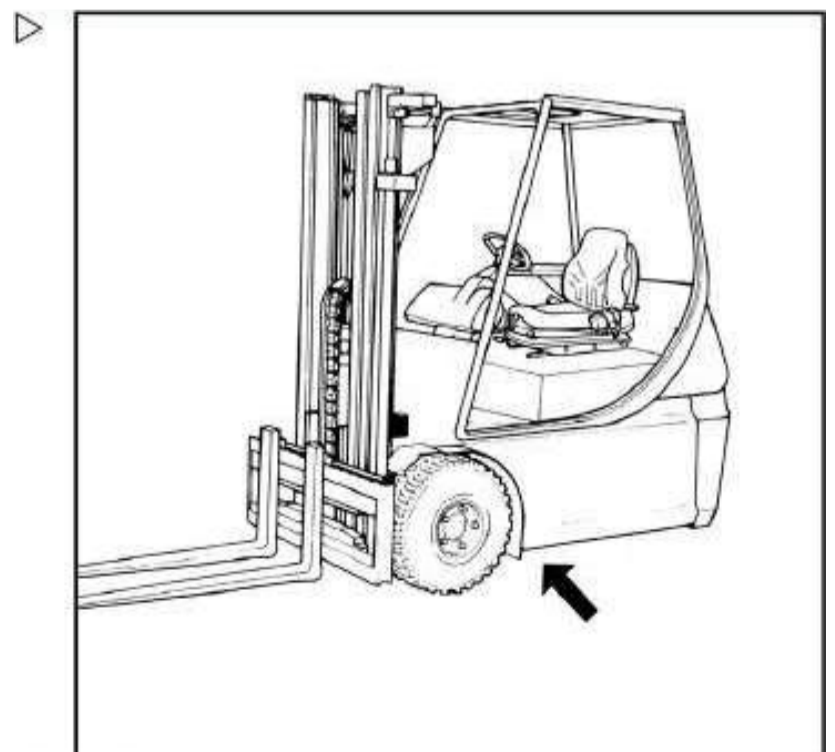

5 Maintenance

Linde Material Handling



Chassis frame

Chassis frame

Check the brake system

⚠ WARNING

The hand brake (1) and brake pedal (2) must be used correctly. If there are serious signs of mechanical abrasion (e.g. abrasion on the brake pads or scratches on the brake discs), please contact your Linde dealer.

- Open the overhead guard to the 2 lock position.

⚠ WARNING

The brake fluid level must be higher than the lowest marking (1), otherwise a decline in braking performance will result. Use the correct brake fluid according to recommended oil types. If the brake fluid is used up very quickly, please contact your Linde dealer.

- Clean the main brake oil cylinder and brake pads with compressed air, and check them for abrasion.
- Tighten all loose brake oil pipe joint connections.

Check the hydraulic foot brake/brake pedal

⚠ DANGER

A defective brake system not only entails a risk of injury but also possible fatality to the driver and anyone in his immediate environment.

The functioning of the brakes should be checked every time prior to starting operation. If there is a fault in the braking system, operation of the truck must stop immediately. Use of the truck can only resume after it has been confirmed that the functioning of the braking system is completely normal.

Please contact your authorised Linde dealer.

⚠ DANGER

The truck's brake performance can be affected by many factors, including oil viscosity. Use of any oil that is not prescribed by the manufacturer (with a different viscosity) will cause an increase in the stopping distance of the truck and therefore increase the risk of accidents.

Therefore, only use the oil prescribed by the manufacturer (see Recommendations for consumables).

Please contact your authorised dealer.

- Drive the truck at high speed.
- Use your foot to depress the brake pedal (2).
- The truck must immediately come to a standstill when the stop pedal is pressed.

i NOTE

In order to ensure maximum brake force when depressing the brake pedal, a gap of 3 millimetres must be maintained between the lower edge of the brake pedal and the rubber pads on the baseplate. If this gap cannot be maintained, then the brake stroke must be adjusted to ensure optimum brake performance.

Please contact your authorised dealer.

Check the parking brake for correct operation**⚠ DANGER**

For example, incorrect adjustments to the brake cables may result in insufficient braking action from the parking brake. Normal functioning of the parking brake and the stop pedal must be maintained at all times.

Should you notice any defects, please contact your authorised dealer at once.

- Drive a fully loaded truck up a 15% slope.
- Depress the brake pedal to stop the truck on the slope.
- Apply the hand brake. In normal conditions, the hand brake should pull tight within the space of 3-4 teeth.

<https://www.forkliftpdfmanuals.com/>

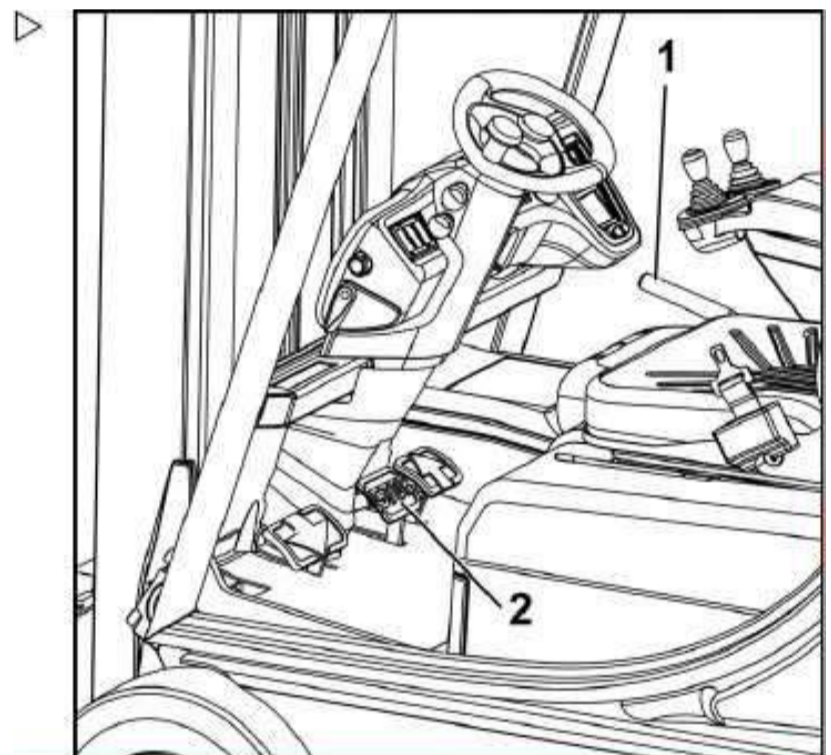

5 Maintenance

Chassis frame

Linde Material Handling



At this time, the parking brake has already been exerted.

- Release the brake pedal. The truck should stop on the slope, and not slide.

Check the Linde automatic brake (LBC)

- Release the accelerator pedal (1 or 3) when moving. The pedal will return to the neutral position and the truck will brake automatically.

NOTE

This function can be adjusted using the Linde diagnostic unit.

Tighten the wheel nuts

CAUTION

The nuts must be tightened at least once every 100 operating hours.

- Check the tightening torque of all tyre nuts:
front tyre/rear tyre 210NmNm

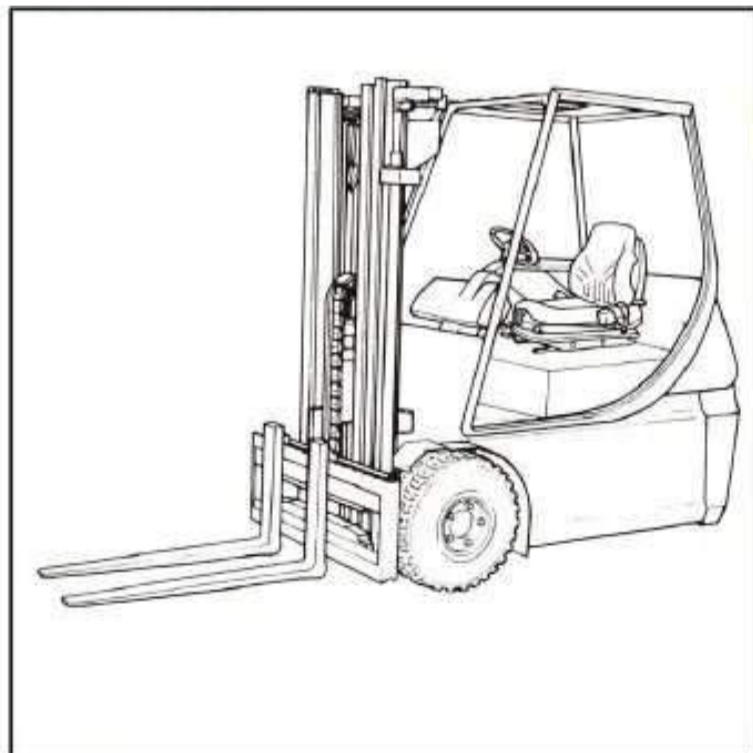

Cleaning/lubricating the steering axle

Cleaning the steering axle

▲ CAUTION

Press the emergency off switch.

Do not allow water to splash into the electrical system (digital control device).

- Use water or a cold cleaning agent to carefully clean the compact steering axle and the swing steering axle.

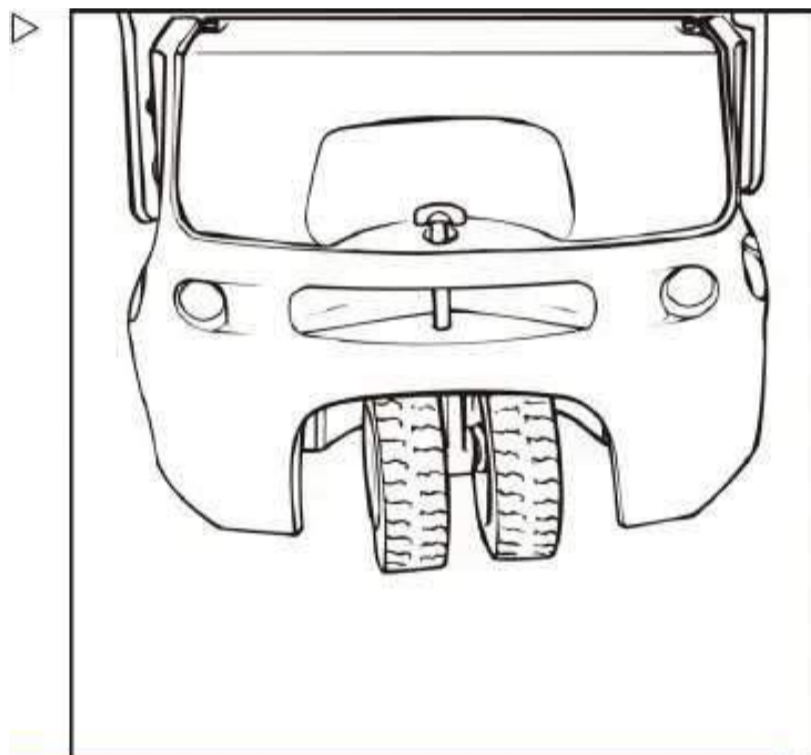

Lubricating the steering axle

- Use lubricating grease to lubricate the piston rod of the steering cylinder through the right and left injection nozzles (shown by the arrow).
- Lubricate with a grease gun until the fresh oil overflows.

If working in a clean and dry area, the steering axle should be lubricated once every 1,000 operating hours. If the truck is used both inside and outside, we recommend that the time between lubrications be between 500-1,000 hours; however, the truck must be lubricated at least once every 12 months.

If working in dusty, dirty or chemical environments, lubricating once a week will extend the operating life of the bearing.

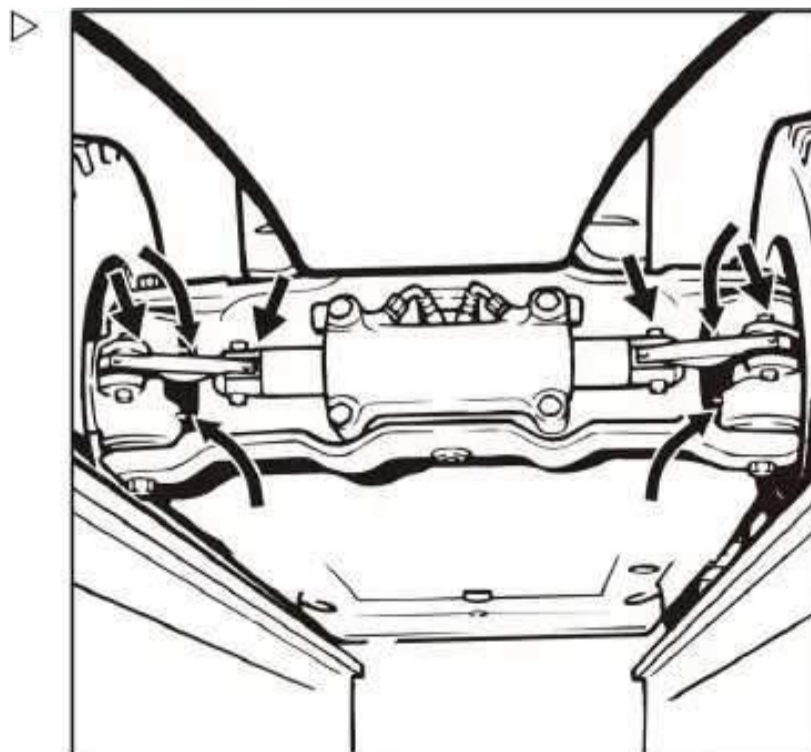

5 Maintenance

Chassis frame

Linde Material Handling



We recommend that lubricating be carried out after steam cleaning.

NOTE

Using a little lubricating grease and lubricating often is better than using a lot of lubricating grease and lubricating infrequently.

Replacing the brake fluid

Replace the oil cup brake fluid

ENVIRONMENT NOTE

Follow the regulations for the safe handling of oil and lubricating grease.

- Open the overhead guard to the 2lock position.

WARNING

The brake fluid level must be higher than the lowest marking (1), otherwise a decline in braking performance will result.

Use the correct brake fluid according to recommended oil types. If the brake fluid is used up very quickly, please contact your Linde dealer.

- Clean the main brake oil cylinder with compressed air, and check for abrasion.
- Tighten all loose brake oil pipe joint connections.

WARNING

The brake fluid must be replaced at least once every 2 years. This task, as well as releasing the compressed air in the brake system, can only be carried out by an authorised Linde professional.

Capacity: approximately 100 cc

Replacing the brake fluid in the drive axle => | 02/2013

NOTE

The type of drive axle brake fluid has changed from "Shell Donax TX" to "Shell Spirax S4 ATF".

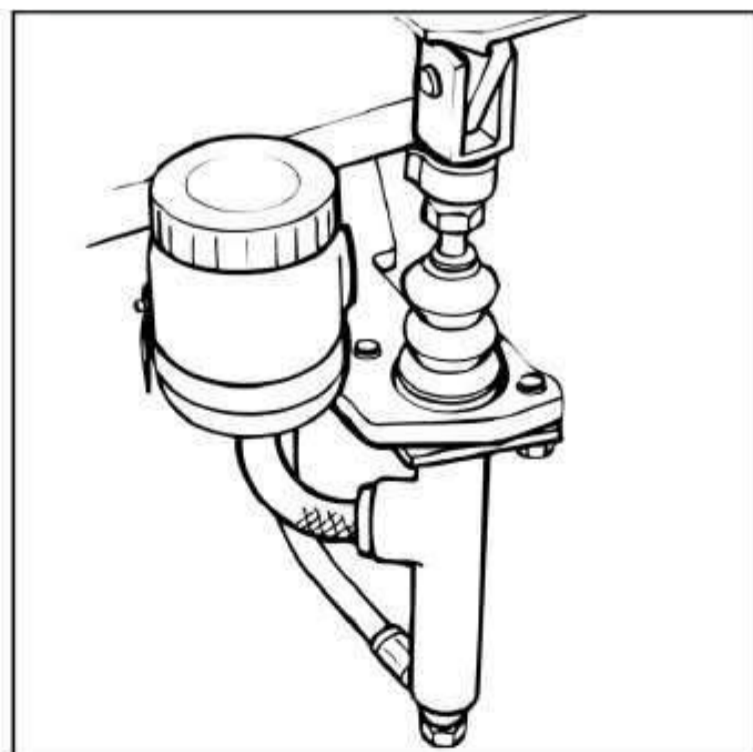

HDX"; therefore, cancel replacement of drive axle brake fluid.

ENVIRONMENT NOTE

Follow the regulations for the safe handling of oil and lubricating grease.

- Operate the truck until the speed reduction gearbox is slightly warm.
- Stop the truck in a horizontal position in order to drain the gear oil completely.
- Clean the oil drain plug (2), filling plug (1) and surrounding areas.
- Place a container under the oil drain plug (2).
- Disassemble the oil drain plug (2), filling plug (1).
- Completely drain the brake fluid.
- Clean the oil drain plug (2).
- Reinstall and tighten the oil drain plug with sealing ring (2).

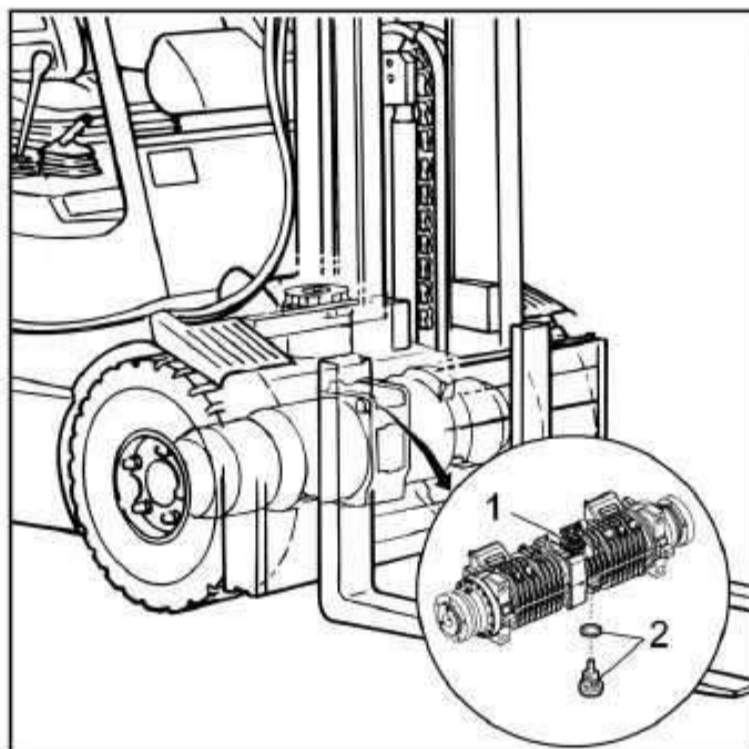

Oil drain plug torque: 20Nm

- Pour approximately 500 of brake fluid from the filling port into the brake box.
- Tighten the filling plug (2).

Filling plug torque: .20Nm

Operating devices

Checking the joystick pad

- Check the pad is properly in place and whether or not it is damaged. If necessary, replace the pad.

Checking and lubricating the pedal mechanisms, control linkage mechanisms and the overhead guard locking devices

<https://www.forkliftpdfmanuals.com/>

5 Maintenance

Linde Material Handling



Electrical system

Adjustment of the acceleration sensor (6) may only be carried out by a professional. Please contact your Linde dealer.

- Lift the overhead guard into the 2 nd lock position.
- Check that the pins and connection points are securely fastened.
- Lightly lubricate the pin shafts and connection points if necessary.
- Check the elasticity of the springs (3).
- Lightly lubricate the locks (2), Bowden cables (1) and springs (3).
- Lubricate the steering cut-out (5).
- Use Molikote-G synthetic grease to lubricate the contact surface between the pedals and the swivel lever (4) if necessary. (If you do not have this synthetic grease, it can be substituted with lubricating oil, but not lubricating grease).
- Close the overhead guard.

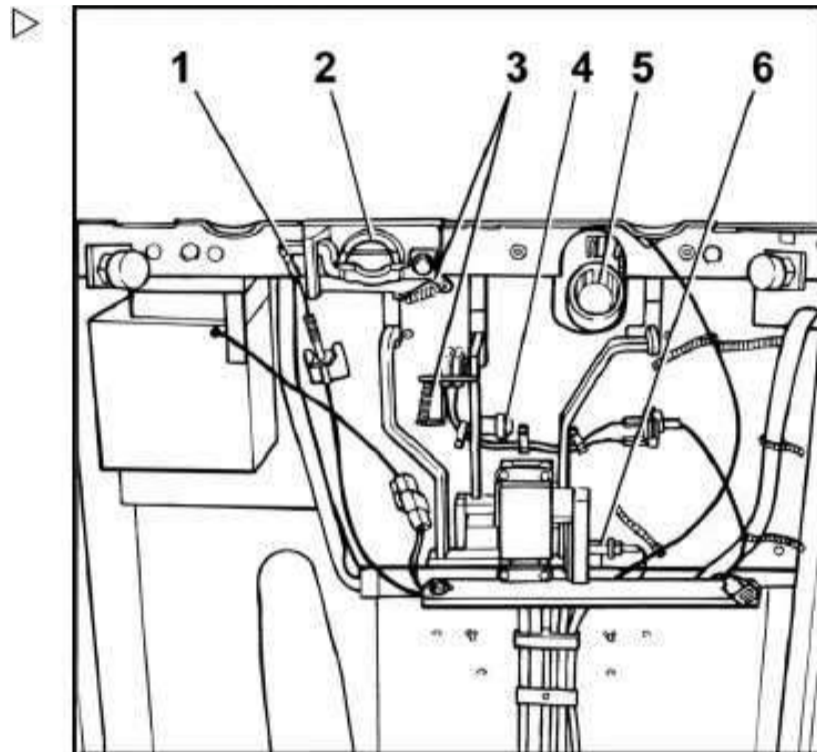

Electrical system

Checking the status and tightness of the electrical cables, electrical connections and plug connectors

NOTE

Apply the hand brake and press the emergency isolator button before carrying out this maintenance task.

- Open the overhead guard to the 1st lock position.
- Motor terminals: check the tightness of the connections and whether or not there is any oxidation or rust.
- Check that the battery cables are secure.
- Close the overhead guard and open the rubber hood or electrical system cover.
- Check whether the cables have failed, whether there is damage to the insulation and the tightness of the connections.

i NOTE

Oxidised and rusted connections and broken cables will lead to a drop in voltage, causing the truck to malfunction.

- Remove and lubricate the oxidised rust, and replace the broken cables.
- Close the rubber hood or electrical system cover.

(As required) Clean the power modules of the traction and lift controls, the fans and the radiator housing with compressed air

- Tilt the lift mast forward slightly. The truck must fully stationary.
- Apply the hand brake.
- Press the emergency off switch.
- Lift the overhead guard into the 2nd lock position.

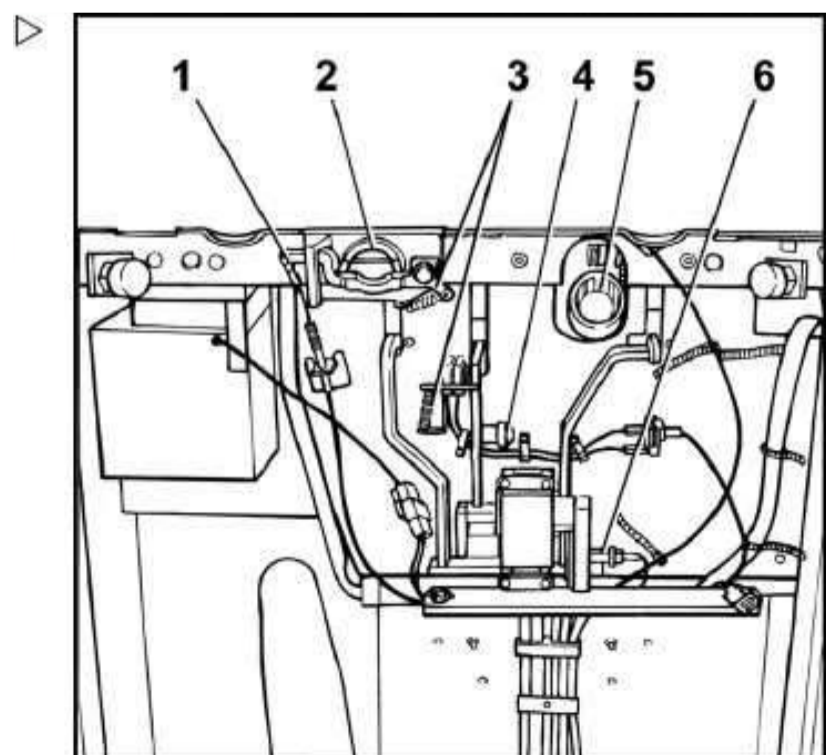
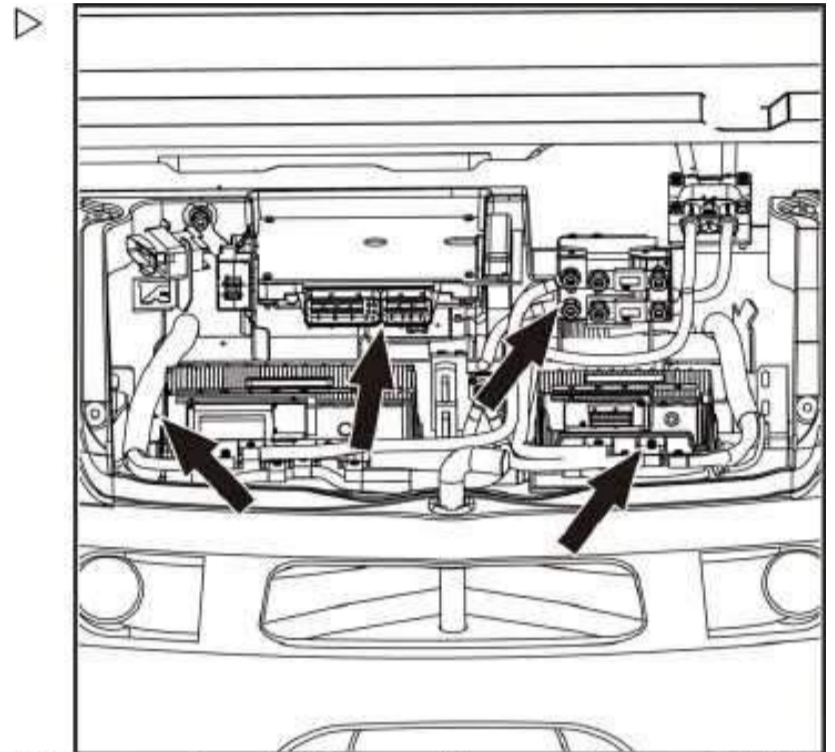

5 Maintenance

Linde Material Handling



Electrical system

- Clean the power modules of the traction and lift controls, and the radiator housing of the traction motor and fuel pump motor with compressed air.

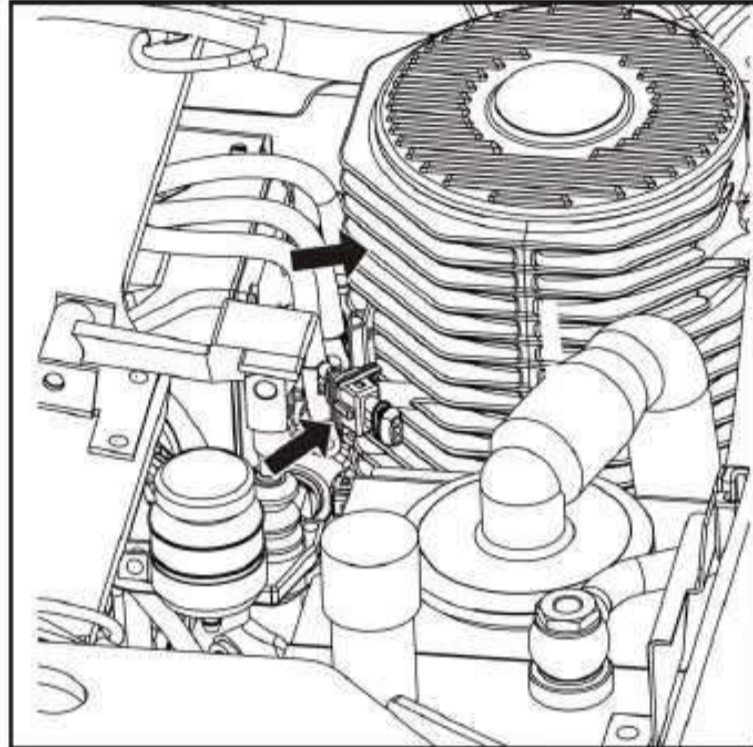

Cleaning the digital control cables

- Tilt the lift mast forward slightly. The truck must fully stationary.
- Apply the hand brake.
- Press the emergency off switch.
- Remove the electrical system cover located on the counterweight.
- Clean the digital control cables with compressed air.

NOTE

The electrical system and the digital control assembly should be protected from moisture damage.

- Re-install the cover.

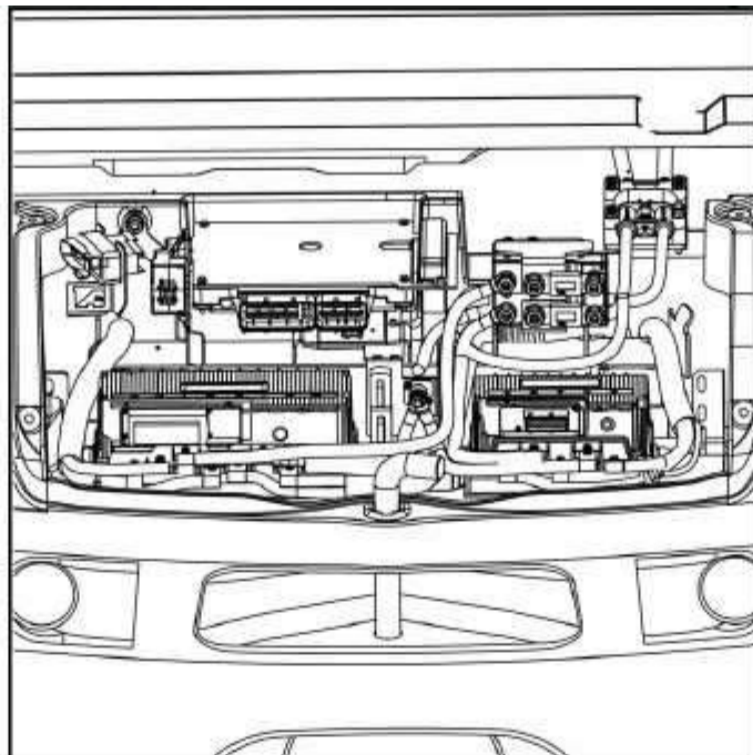

Inspect the contactor contacts, and replace if necessary

- Open the electrical system hood.
- Loosen the bolt torque and remove the cover (1).
- Check the contactor contacts and replace if necessary (the contacts cannot be repaired). Please contact your Linde dealer.

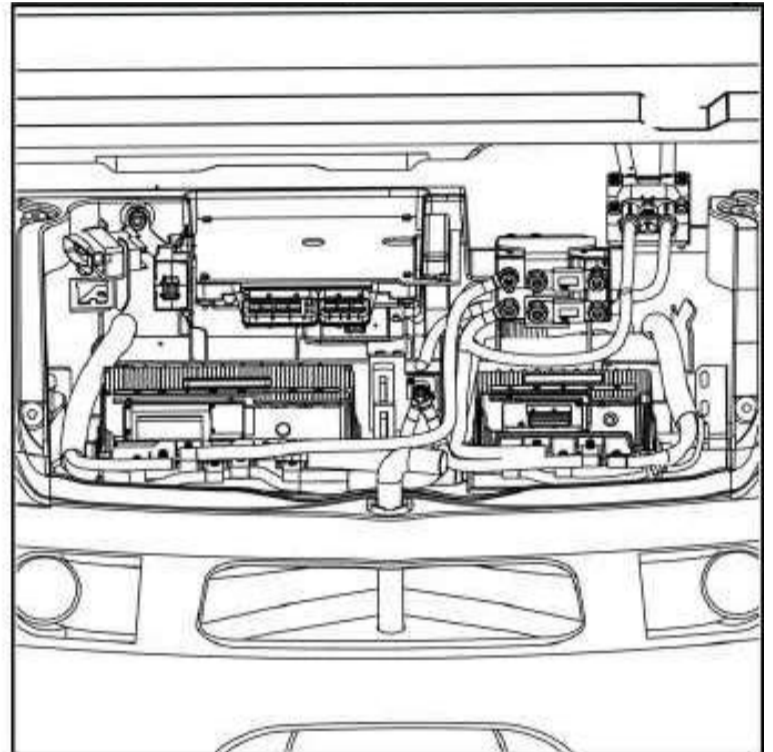

Hydraulic system

Check the hydraulic oil level



ENVIRONMENT NOTE

Please follow the measures for the safe handling of oil and lubricating grease.



NOTE

The oil level can only be checked after lowering the lift mast.

5 Maintenance

Hydraulic system

Linde Material Handling



- Apply the hand brake.
- Press the emergency disconnect button.
- Lift the overhead guard (1) into the lock position.

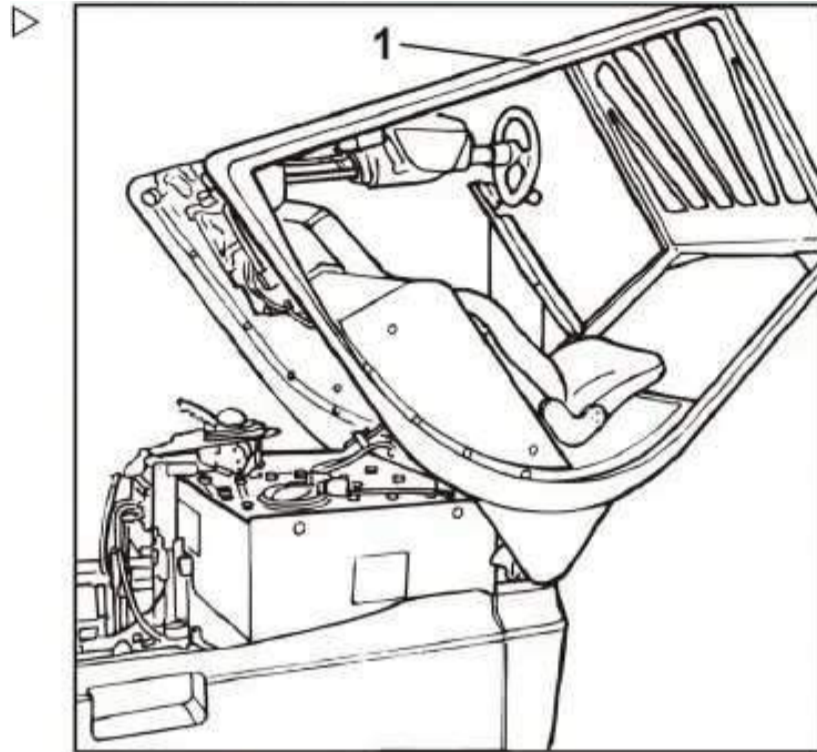

- Remove the air filter with the oil gauge (2).
- Use a clean cloth to dry the oil gauge.
- Completely insert the air filter and dipstick once more, and then remove again.
- The oil level should be between the upper and lower markings on the dipstick.
- If required, fill the hydraulic oil up to the upper marking.
- Reinstall the air filter.
- Completely lower the overhead guard.

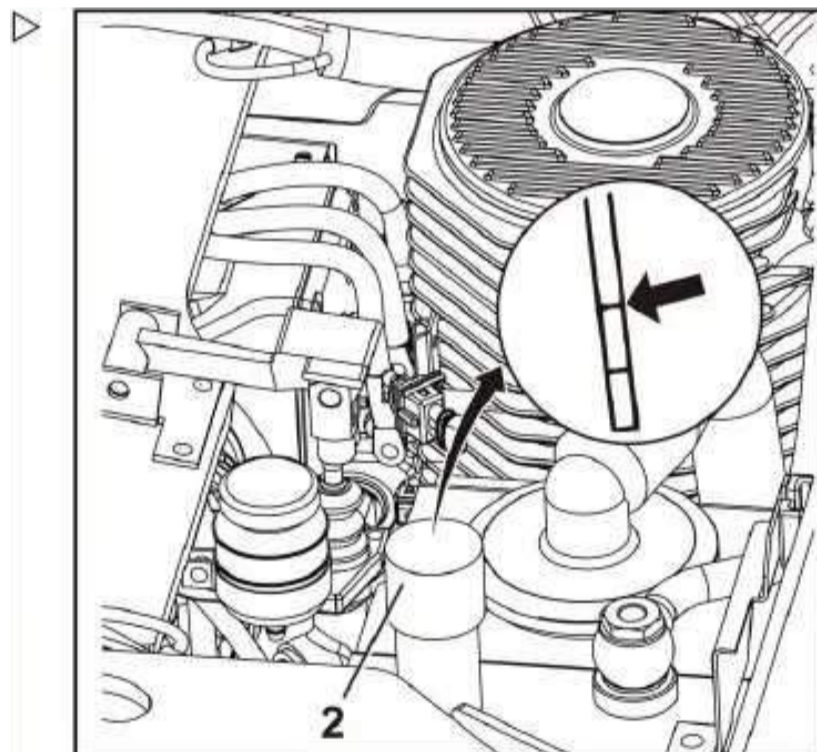

Checking the leak resistance of the working and steering hydraulic systems

- Lift the overhead guard into the 2ndlock position.
- Check the leak resistance of the working hydraulic pump, the power steering, the valves and the pipe lines.
- Replace the porous hoses.
- Check whether the oil pipes and hoses have scratches and replace if necessary.
- Close the overhead guard.

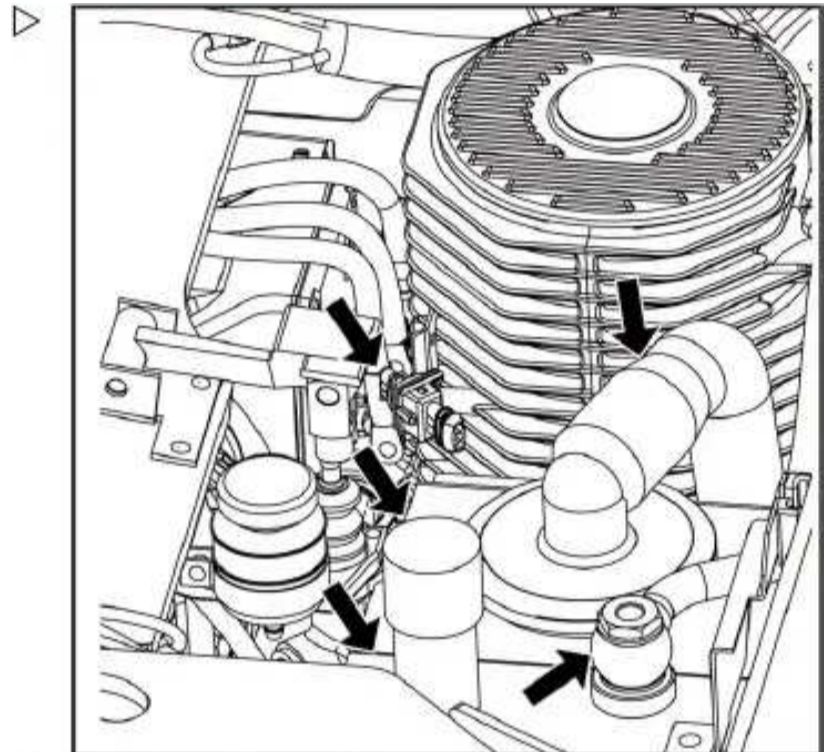

Replacing the air, pressure and suction filters

ENVIRONMENT NOTE

Follow the regulations for the safe handling of oil and lubricating grease.

- Lift the overhead guard into the 2ndlock position.
- Remove the air filter (2) and the dipstick together from the refuelling port.
- Remove the dipstick (1) from the filter and install onto the new filter.
- Install the new air filter.
- Close the overhead guard completely.

NOTE

It will be necessary to replace the filter earlier in poor working environments.

ENVIRONMENT NOTE

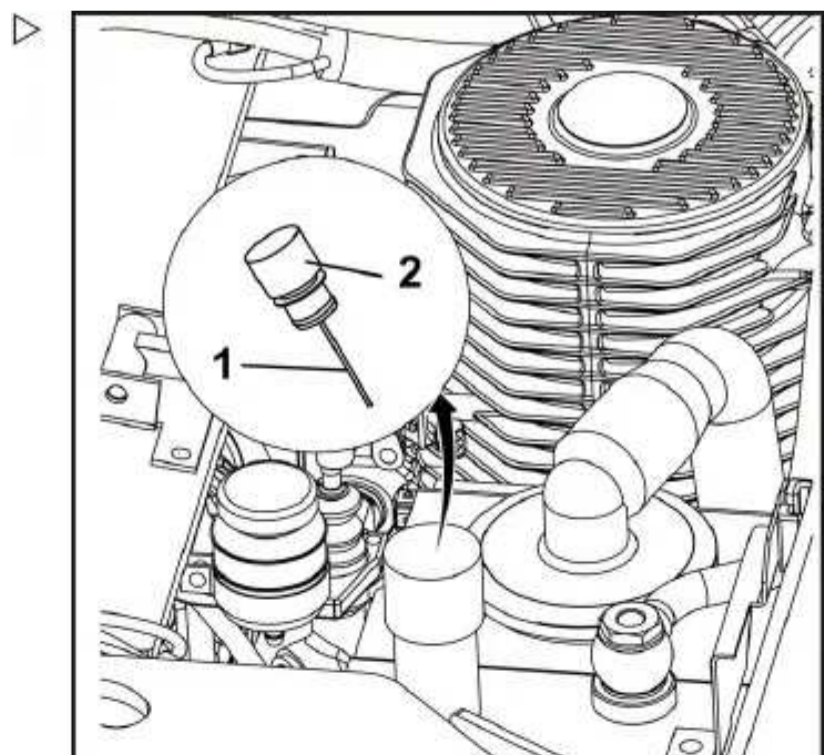

5 Maintenance

Hydraulic system

Linde Material Handling



NOTE

The hydraulic oil will flow out. Place an oil pan under the filter.

- Lift the overhead guard into the 2nd lock position.
- Use an extension to undo the filter housing (3) from the bottom left of the truck.
- Remove the filter housing and the upper cover.

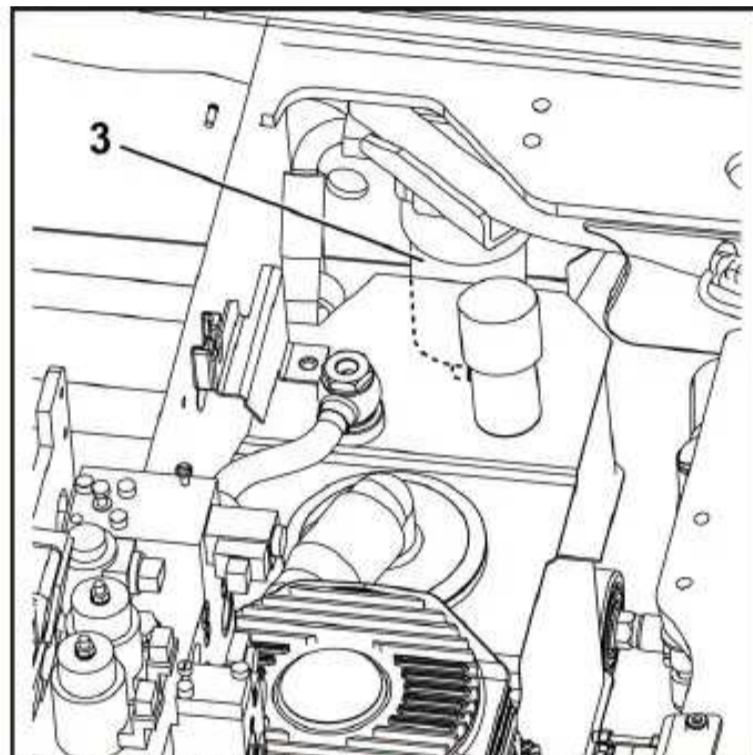

- Take out the filter insert (4).
- Check the O-ring on the filter cover, and replace if damaged.
- Install the new filter insert.
- Screw into the filter housing (3) until it makes contact with the O-ring on the filter cover, and then use a 40Nm torque to tighten.
- Operating the working hydraulic system, checking the leak resistance of the pressure filter.
- Close the overhead guard completely.

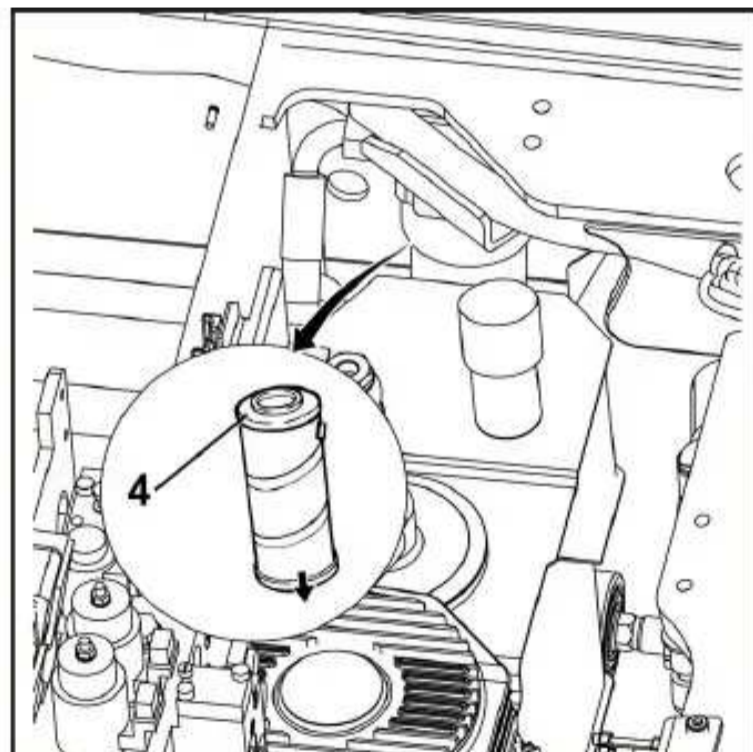

ENVIRONMENT NOTE

Follow the regulations for the safe handling of oil and lubricating grease.

- Lift the overhead guard into the 2ndlock position.
- Unscrew the clamp nut (6) on the clamp belt on the suction filter hood (5).
- Use the clamp belt to remove the suction filter.
- Slowly take out the filters so that the hydraulic oil can flow back into the oil tank.
- Carefully insert the new suction filter into the oil tank.
- Clean the filter hood seal ring, lightly lubricate and reinstall.
- Use the clamp belt to reinstall the filter hood, and lock securely with the clamp nut.
- Perform a trial run to check that the filter hood is properly sealed.
- Remove the air filter (2) and oil gauge and inspect the oil level. If necessary, fill the hydraulic oil up to the upper marking on the oil gauge.
- Install the air filter.
- Close the overhead guard.

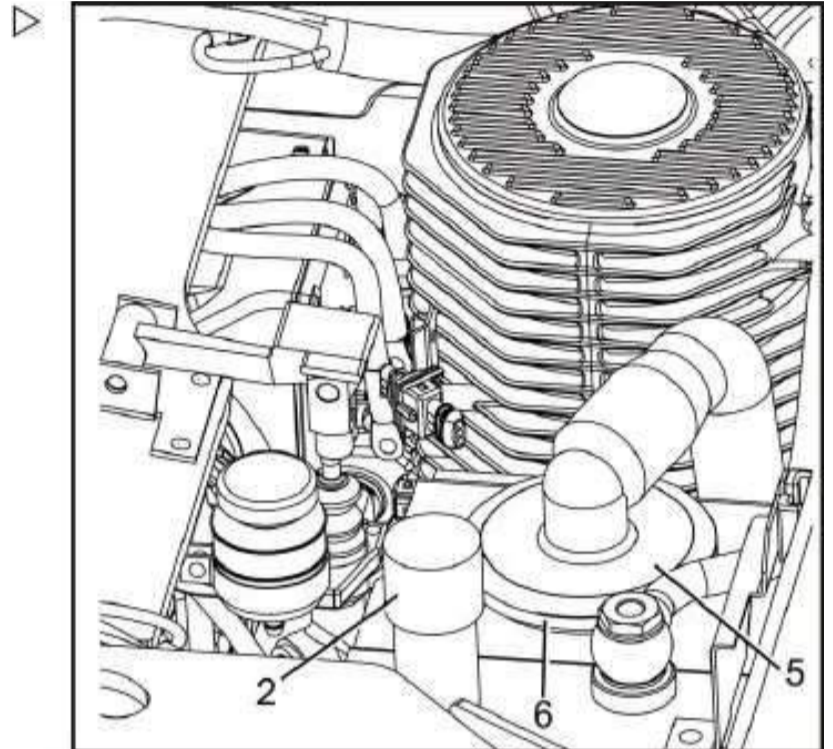

Replacing the hydraulic oil (if it is Bio hydraulic oil, the Aral Forbex SE46 is 6000operating hours)



ENVIRONMENT NOTE

Follow the regulations for the safe handling of oil and lubricating grease.



NOTE

An appropriate tool (e.g. a hand pump) must be used to pump out the hydraulic oil.

5 Maintenance

Hydraulic system

- Lower the fork carriage to its full extent.
- Open the overhead guard into the 2lock position.
- Unscrew the clamp nut (4) on the suction filter cover (3).
- Use the clamp belt to remove the suction filter cover.
- Slowly take out the filter, allowing the hydraulic oil to flow back into the oil tank.
- Use the hand pump to pump out the hydraulic oil.
- Fill up with new hydraulic oil.
The capacity of the hydraulic oil tank.....is approximately 11.0litres
- Carefully install the new suction filter into the oil tank.
- Clean and paint a thin layer of engine oil on the filter cover sealing ring, and then install by hand.
- Use the clamp belt to tighten the suction filter cover and fasten with the bolt torque.
- Check the leak resistance of the filter.
- Take out the air filter (2), and use the dipstick (1) to check the oil level. Add hydraulic oil as required, up to the upper marking on the dipstick.
- Reinstall the air filter.
- Close the overhead guard.

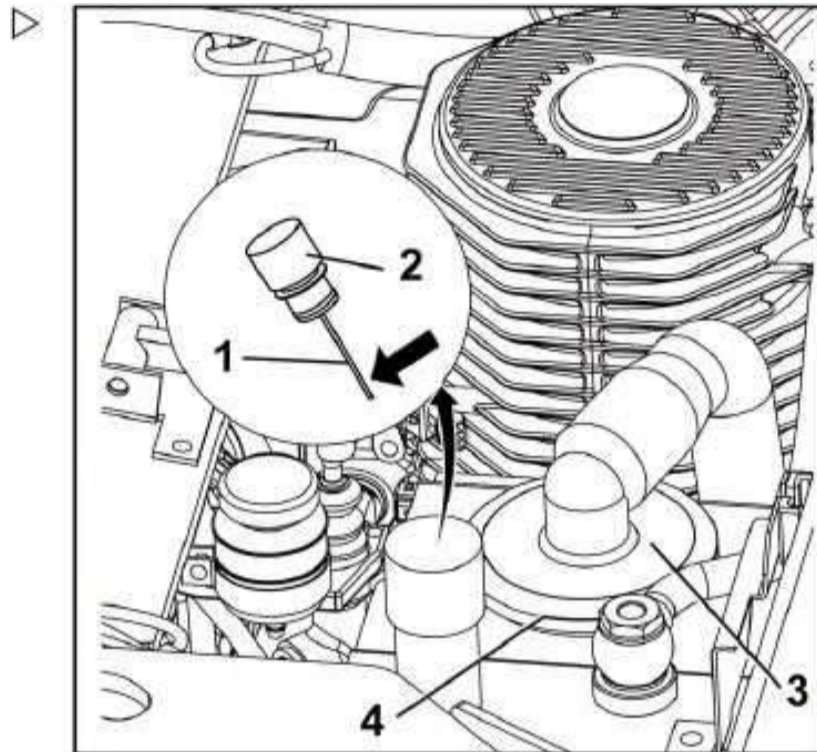

Load lift system

Checking the condition, tightness and function of the lift mast, lift chains and stop block

- Thoroughly clean the mast channel and lift chains. ▷
- Check the status of the lift chains, along with any signs of abrasion, paying particular attention to the area around the chain wheels.
- Check that the chain fixed pins are secure.
- Replace damaged chains.

NOTE

Damaged or missing plastic connectors will not affect the performance and operating life of the lift chains.

- Check the status and tightness of the lift mast, channel surfaces and roller.
- Check the status and function of the stop block.
- Check the tightness of the piston rod retaining ring on the top of the lift mast.

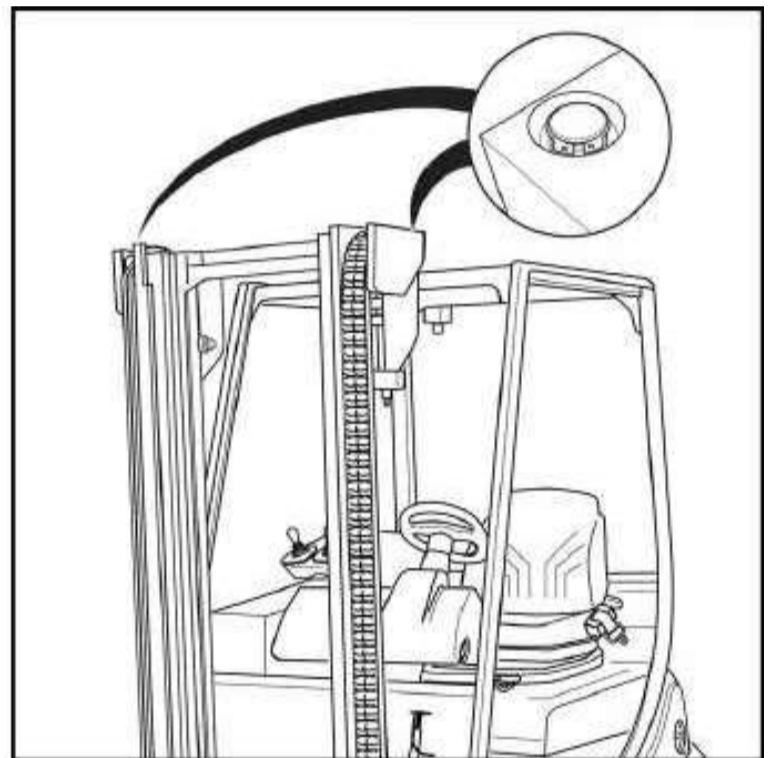

5 Maintenance

Load lift system

Linde Material Handling



Adjusting the length of the lift chains, and lubricating using chain spray

Adjusting the length of the lift chains*

NOTE

Use over time will cause the lift chains to stretch, therefore it is necessary to check and adjust the lengths of both the left and right chains.

- Fully lower the lift mast.
- Undo the lock nut (1).
- Adjust the adjustable nut on the fixed pin of the chain (2) to adjust the chain length. The guide pulley under the fork carriage can extend to a maximum of 25 millimetres out from the mast channel.
- Tighten the lock nut (1).
- Adjust the 2nd chain.

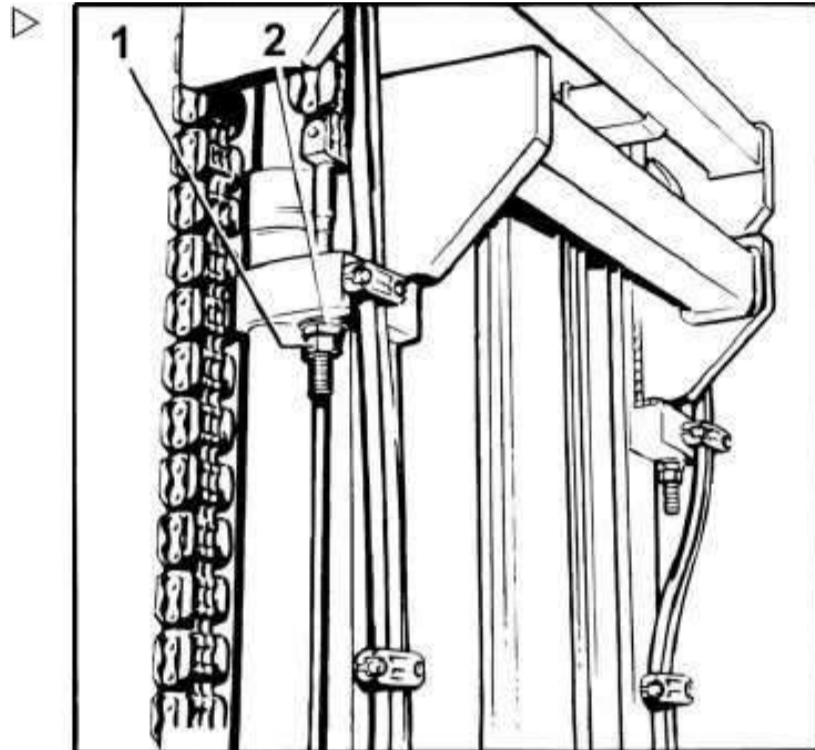

Lubricating the chains with chain spray

- Use Linde chain spray to coat the chains and channel surfaces.

NOTE

If the truck is used in the food industry, please use lubricating grease in place of spray.

* Only for standard masts

Adjusting the length of the lift chains*

NOTE

Use over time will cause the lift chains to stretch, therefore it is necessary to check and adjust their lengths.

- Fully lower the lift mast.
- Undo the lock nut (1).
- Adjust the adjustable nut on the fixed pin of the chain (2) to adjust the chain length. The guide pulley under the fork carriage can extend to a maximum of 25 millimetres out from the mast channel.
- Tighten the lock nut (1).

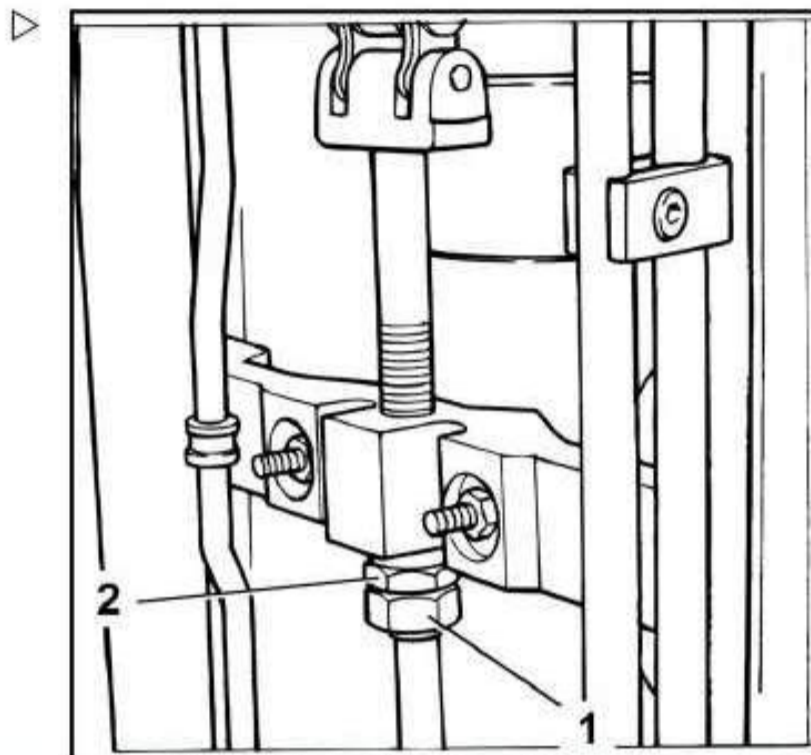

Lubricating the chains with chain spray

- Use Linde chain spray to coat the chains and channel surfaces.

NOTE

If the truck is used in the food industry, please use lubricating grease in place of spray.

* Only for completely free lifting and triple masts

Checking the truck's releasing and locking equipment

- Check whether the truck shows serious signs of distortion or damage.
- Check whether the rapid release screws (2, 3) and the truck lock (1) are installed correctly, or are damaged.
- Replace damaged parts.

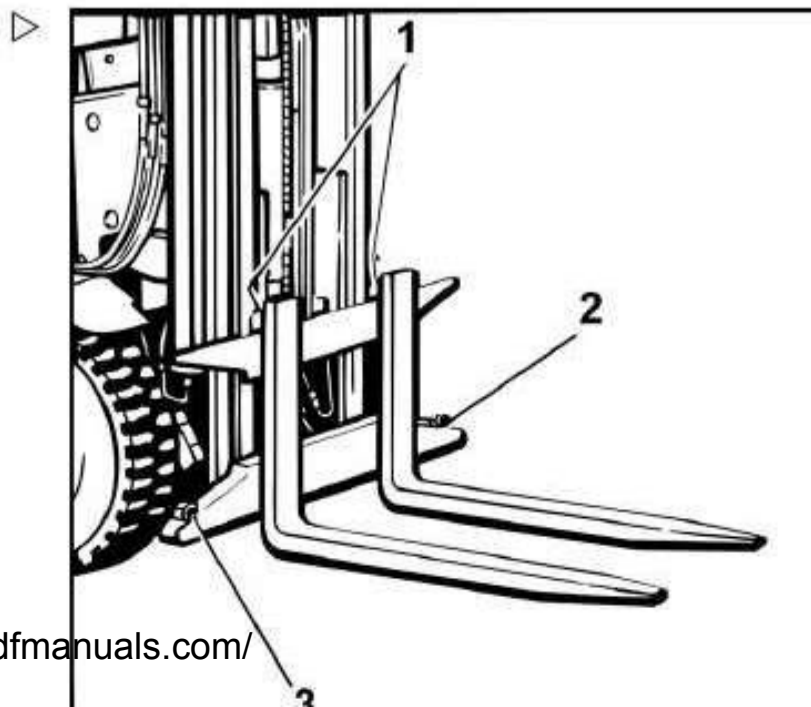

5 Maintenance

Load lift system

Linde Material Handling

The Linde logo, featuring the word "Linde" in a white, stylized script font on a red background.

6

Technical data

6 Technical data

List of technical parameter marks

List of technical parameter marks

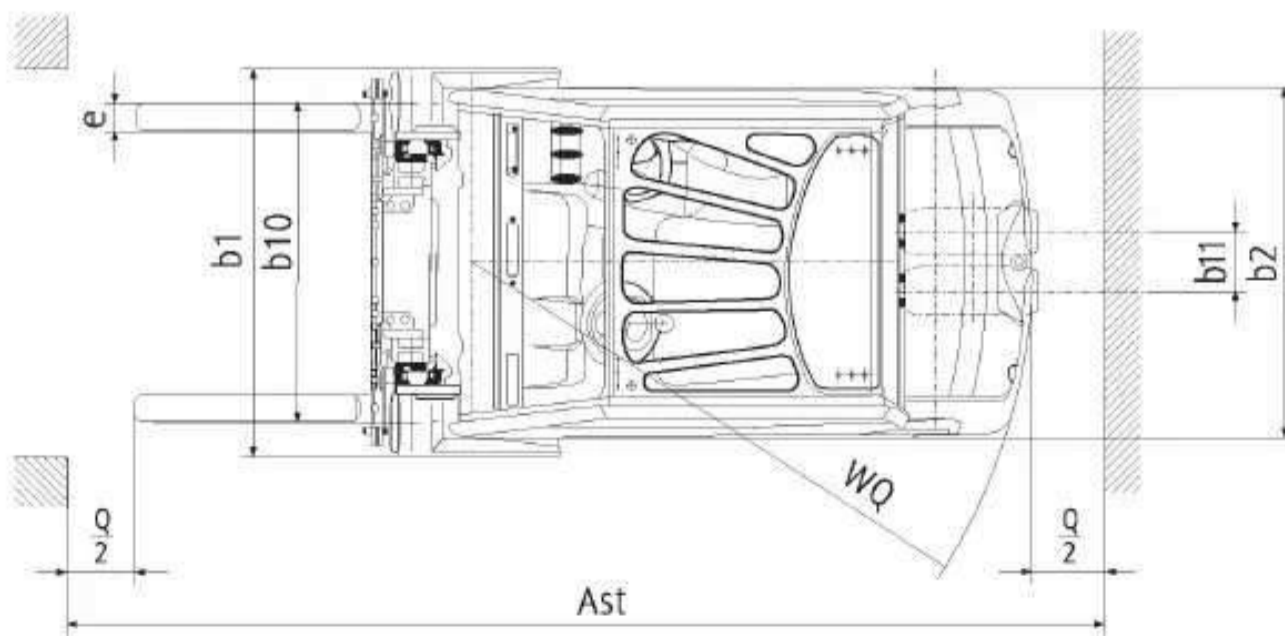
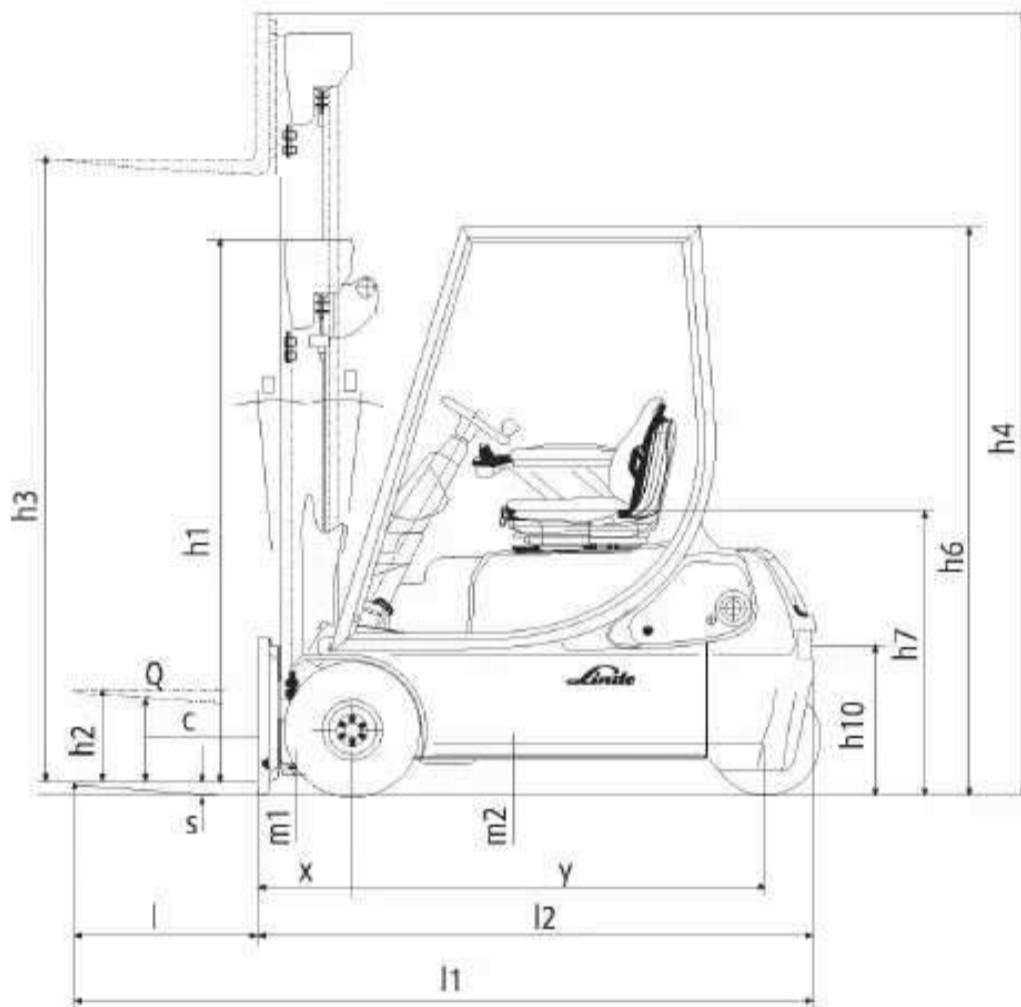

Technical parameters – E16P forklift

Characteristics				
1.1	Manufacturer			Linde
1.2	Model No.			E16C
1.3	Power: electrical, diesel, petrol, LPG, mains power supply			Electric
1.4	Driving method			Seated
1.5	Nominal loading capacity	Q	(kg)	1600
1.6	Load centre of gravity distance	c	mm	500
1.8	Front overhang	x	mm	330 (334/ ¹)
1.9	wheelbase	y	mm	1336 ²⁾

Weight				
2.1	Dead weight (with battery)		kg	3070
2.2	Axle load when fully loaded, front/rear		kg	4205/470 ²⁾
2.3	Axle load without load, front/rear		kg	1550/1520 ²⁾

Wheels				
3.1	Tyres:SE= solid tyres, P= inflated tyres			SE
3.2	Tyre size, front wheel		mm	18x7-8
3.3	Tyre size, rear wheel		mm	15x4 1/2-8
3.5	Number of wheels, front/rear (X = drive wheel)			2x/2
3.6	Track width, drive side	b ₁₀	mm	910
3.7	Track width, load side	b ₁₁	mm	168

Dimensions				
4.1	Lift mast tilt angle, forward/back	α/β	(°)	4.8/4,9
4.2	Height when lift mast retracts	h ₁	mm	2176 ³⁾
4.3	Free lift height	h ₂	mm	150
4.4	Lift heights	h ₃	mm	3250 (4470) ⁴⁾
4.5	Maximum mast height when in operation	h ₄	mm	3863 (5078) ⁴⁾
4.7	Overhead guard (driver's cabin) height	h ₆	mm	1970
4.8	Seat height above ground	h ₇	mm	919
4.10	Traction pin height	h ₁₀	mm	510

6 Technical data

Linde Material Handling



Technical parameters – E16P forklift

Dimensions				
4.19	Vehicle length	l ₁	mm	2845 ²⁾
4.20	Body length (without forks)	l ₂	mm	1845 ²⁾
4.21	Body width	b ₁ /b ₂	mm	1083
4.22	For arm dimensions, thickness x width x length	s/e/l	mm	45x100x1000
4.23	Fork carriage, according to DIN 15173, grade A, B			2A.
4.24	Width of fork carriage	b ₃	mm	1040
4.31	Ground clearance, mast	m ₁	mm	78
4.32	Ground clearance at centre of wheelbase	m ₂	mm	113
4.33	Right angle stacking aisle width, pallet 1000 x 1200 (1200 cross-fork placement)	A _{st}	mm	3171 (3175) ^{1) 2)}
4.34	Right angle stacking aisle width, pallet 800 x 1200 (1200 along forks)	A _{st}	mm	3293 (3297) ^{1) 2)}
4.35	Turning radius	W _a	mm	1512 ²⁾
4.36	Minimum distance from turning centreline to body centreline	l ₇	mm	0

PERFORMANCE				
5.1	Driving speed, full/no load		km/h	15.8/15,8
5.2	Lifting speed, full load/no load		m/s	0,44/0,52
5.3	Lowering speed, full/no load		m/s	0,51 / 0,51
5.5	Rated traction, full/no load (60 minutes)		N	1900 / 1900
5.6	Maximum traction (5 minutes), full load, no load		N	9200 / 9200
5.7	Climbing capability, full/no load (30 minutes)		%	10.1 / 15.5
5.8	Maximum climbing capability (5 minutes), full load/no load		%	20.5 / 32.1
5.9	Acceleration time, full/no load (first 10 metres)		s	4.9/4,4
5.10	Service brake			Hydraulic / mechanical

DRIVE				
6.1	Drive motor (60 minutes)		kW	2 X 4
6.2	Lift motor 15% power		kW	8.5
6.3	Battery, in line with DIN43 535/36 A, B, C			43 531 A.
6.4	Battery voltage/capacity (5-hour discharge)		V/Ah	48/550
6.5	Battery weight	https://www.forkliftpdfmanuals.com/	kg	856

Linde Material Handling 	Technical data 6
Technical parameters – E16P forklift	

Other				
8.1	Control method			Microprocessor control
8.2	Working hydraulic pressure for attachments		bar	200
8.3	Fuel consumption for attachments		l/min	20 ⁵⁾
8.4	Noise level at driver's ear		dB (A)	-

Standard forklift parameters may change based on the actual equipment

- 1) The data in brackets refers to the triple mast.
- 2) Mast located in a vertical position
- 3) 150 mm completely free lift.
- 4) For other lift heights, please refer to further mast tables.
- 5) At 80% of rated pressure.



6 Technical data

Technical parameters – E16P forklift

Technical parameters – E16P forklift

Characteristics				
1.1	Manufacturer			Linde
1.2	Model No.			E16P
1.3	Power: electrical, diesel, petrol, LPG, mains power supply			Electric
1.4	Driving method			Seated
1.5	Nominal loading capacity	Q	(kg)	1600
1.6	Load centre of gravity distance	c	mm	500
1.8	Front overhang	x	mm	330 (334 ¹⁾)
1.9	wheelbase	y	mm	1422 ²⁾

Weight				
2.1	Dead weight (with battery)		kg	3225
2.2	Axle load when fully loaded, front/rear		kg	4270/560 ²⁾
2.3	Axle load without load, front/rear		kg	1675/1550 ²⁾

Wheels				
3.1	Tyres:SE= solid tyres, P= inflated tyres			SE
3.2	Tyre size, front wheel		mm	18x7-8
3.3	Tyre size, rear wheel		mm	16x6-8
3.5	Number of wheels, front/rear (X = drive wheel)			2x/2
3.6	Track width, drive side	b ₁₀	mm	910
3.7	Track width, load side	b ₁₁	mm	874

Dimensions				
4.1	Lift mast tilt angle, forward/back	α/β	(°)	4.6/5,0
4.2	Height when lift mast retracts	h ₁	mm	2176 ³⁾
4.3	Free lift height	h ₂	mm	150
4.4	Lift heights	h ₃	mm	3250 (4470) ⁴⁾
4.5	Maximum mast height when in operation	h ₄	mm	3863 (5083) ⁴⁾
4.7	Overhead guard (driver's cabin) height	h ₆	mm	2075
4.8	Seat height above ground https://www.forkliftpdfmanuals.com/		mm	1024

Dimensions				
4.19	Vehicle length	l ₁	mm	2970 ²⁾
4.20	Body length (without forks)	l ₂	mm	1970 ²⁾
4.21	Body width	b ₁ /b ₂	mm	1083
4.22	For arm dimensions, thickness x width x length	s/e/l	mm	45 x 100 x 1000
4.23	Fork carriage, according to DIN 15173, grade A, B			2A.
4.24	Width of fork carriage	b ₃	mm	1040
4.31	Ground clearance, mast	m ₁	mm	77
4.32	Ground clearance at centre of wheelbase	m ₂	mm	113
4.33	Right angle stacking aisle width, pallet 1000 x 1200 (1200 cross-fork placement)	A _{st}	mm	3408 (3412) ¹⁾²⁾
4.34	Right angle stacking aisle width, pallet 800 x 1200 (1200 along forks)	A _{st}	mm	3608 (3612) ¹⁾²⁾
4.35	Turning radius	W _a	mm	1878 ²⁾
4.36	Minimum distance from turning centreline to body centreline	l ₇	mm	571

PERFORMANCE

5.1	Driving speed, full/no load		km/h	15.8/15,8
5.2	Lifting speed, full load/no load		m/s	0,44/0,52
5.3	Lowering speed, full/no load		m/s	0,51 / 0,51
5.5	Rated traction, full/no load (60 minutes)		N	1900 / 1900
5.6	Maximum traction (5 minutes), full load, no load		N	9200 / 9200
5.7	Climbing capability, full/no load (30 minutes)		%	9.8/14.7
5.8	Maximum climbing capability (5 minutes), full load/no load		%	19.8/30.4
5.9	Acceleration time, full/no load (first 10 metres)		s	4.9/4,4
5.10	Service brake			Hydraulic / mechanical

DRIVE

6.1	Drive motor (60 minutes)		kW	2 X 4
6.2	Lift motor 15% power		kW	8.5
6.3	Battery, in line with DIN43 535/36 A, B, C			43 531 A.
6.4	Battery voltage/capacity (5-hour discharge)		V/Ah	48/700
6.5	Battery weight	https://www.forkliftpdfmanuals.com/	kg	1118

6 Technical data

Linde Material Handling



Technical parameters – E16P forklift

Other				
8.1	Control method			Microprocessor control
8.2	Working hydraulic pressure for attachments		bar	200
8.3	Fuel consumption for attachments		l/min	20 ⁵⁾
8.4	Noise level at driver's ear		dB (A)	-

1) The data in brackets refers to the triple mast.

2) Mast located in a vertical position

3) 150mm completely free lift.

4) For other lift heights, please refer to further mast tables.

5) At 80% of rated pressure.

Technical parameters – E20P forklift

Characteristics				
1.1	Manufacturer			Linde
1.2	Model No.			E20P
1.3	Power: electrical, diesel, petrol, LPG, mains power supply			Electric
1.4	Driving method			Seated
1.5	Nominal loading capacity	Q	(kg)	2000
1.6	Load centre of gravity distance	c	mm	500
1.8	Front overhang	x	mm	330 (334/ ¹)
1.9	wheelbase	y	mm	1422 ²⁾

Weight				
2.1	Dead weight (with battery)		Kg	3550
2.2	Axle load when fully loaded, front/rear		kg	4910/680 ²⁾
2.3	Axle load without load, front/rear		kg	1670/1880 ²⁾

Wheels				
3.1	Tyres:SE= solid tyres, P= inflated tyres			SE
3.2	Tyre size, front wheel		mm	200/50-10
3.3	Tyre size, rear wheel		mm	16x6-8
3.5	Number of wheels, front/rear (X = drive wheel)			2x/2
3.6	Track width, drive side	b ₁₀	mm	910
3.7	Track width, load side	b ₁₁	mm	874

Dimensions				
4.1	Lift mast tilt angle, forward/back	α/β	(°)	4.6/5,0
4.2	Height when lift mast retracts	h ₁	mm	2178 ³⁾
4.3	Free lift height	h ₂	mm	150
4.4	Lift heights	h ₃	mm	3250 (4470) ⁴⁾
4.5	Maximum mast height when in operation	h ₄	mm	3863 (5083) ⁴⁾
4.7	Overhead guard (driver's cabin) height	h ₆	mm	2075
4.8	Seat height above ground	h ₇	mm	1024

6 Technical data

Linde Material Handling



Technical parameters – E20P forklift

Dimensions				
4.19	Vehicle length	l ₁	mm	3060 ²⁾
4.20	Body length (without forks)	l ₂	mm	2060 ²⁾
4.21	Body width	b / b ₁₋₂	mm	1155
4.22	For arm dimensions, thickness x width x length	s/e/l	mm	45x100x1000
4.23	Fork carriage, according to DIN 15173, grade A, B			2A.
4.24	Width of fork carriage	b ₃	mm	1040
4.31	Ground clearance, mast	m ₁	mm	83
4.32	Ground clearance at centre of wheelbase	m ₂	mm	118
4.33	Right angle stacking aisle width, pallet 1000 x 1200 (1200 cross-fork placement)	A _{st}	mm	3439 (3443) ^{1) 2)}
4.34	Right angle stacking aisle width, pallet 800 x 1200 (1200 along forks)	A _{st}	mm	3639 (3643) ^{1) 2)}
4.35	Turning radius	W _a	mm	1900 ²⁾
4.36	Minimum distance from turning centreline to body centreline	l ₇	mm	571

PERFORMANCE				
5.1	Driving speed, full/no load		km/h	15.8/15,8
5.2	Lifting speed, full load/no load		m/s	0,37/0,52
5.3	Lowering speed, full/no load		m/s	0,51 / 0,51
5.5	Rated traction, full/no load (60 minutes)		N	1900 / 1900
5.6	Maximum traction (5 minutes), full load, no load		N	9200 / 9200
5.7	Climbing capability, full/no load (30 minutes)		%	8.5/13.3
5.8	Maximum climbing capability (5 minutes), full load/no load		%	17.1 / 27.4
5.9	Acceleration time, full/no load (first 10 metres)		s	5.2 / 4.5
5.10	Service brake			Hydraulic / mechanical

DRIVE				
6.1	Drive motor (60 minutes)		kW	2 X 4
6.2	Lift motor 15% power		kW	98.5
6.3	Battery, in line with DIN43 535/36 A, B, C			43 531 A.
6.4	Battery voltage/capacity (5-hour discharge)		V/Ah	48/700
6.5	Battery weight	https://www.forkliftpdfmanuals.com/	kg	1118

Linde Material Handling 	Technical data 6 Lift mast data
--	---

Other				
8.1	Control method			Microprocessor control
8.2	Working hydraulic pressure for attachments		bar	250
8.3	Fuel consumption for attachments		l/min	20 ⁵⁾
8.4	Noise level at driver's ear		dB (A)	-

Standard forklift parameters may change based on the actual equipment.

- 1) The data in brackets refers to the triple mast.
- 2) Mast located in a vertical position
- 3) 150mm completely free lift.
- 4) For other lift heights, please refer to further mast tables.
- 5) At 80% of rated pressure.

Lift mast data

Standards lift mast (in mm)		E16C	E16C-E20P					
Lift heights	h 3	2850	3050	3250	3850	4250	4850	5650
Total height when lift mast retracts	h 1	1976	2076	2176	2476	2676	2976	3376
Maximum height when lift mast is working	h 4	3463	3663	3863	4463	4863	5463	6263
Free lift height	h 2	150	150	150	150	150	150	150

Duplex lift mast (in mm)		E16C	E16C-E20P	
Lift heights	h 3	2770	3070	
Total height when lift mast retracts	h 1	1919	2069	
Maximum height when lift mast is working	h 4	3383	3683	
Free lift height	h 2	1318	1468	

Triple lift mast (in mm)		E16C	E16C-E20P				
Lift heights	h 3	4020	4470	4770	5470	5920	6220
Total height when lift mast retracts	h 1	1919	2069	2169	2469	2619	2719

6 Technical data



Lift mast data

Triple lift mast (in mm)		E16C	E16C-E20P				
Maximum height when lift mast is working	h 4	4633	5083	5383	6083	6533	6833
Free lift height	h 2	1318	1468	1568	1868	2018	2118