



# Operator Manual

For the Moffett  
Truck-Mounted Forklift  
Equipped with Static Mast



Delivering **Confidence**

# TABLE OF CONTENTS

## A. STANDARD MACHINE

### 1. SAFETY CHECKLIST

Safety Notices	1
Safety Introduction	2
Safety Checklist	3

### 2. INTRODUCTION

#### **About this Operator Manual 13**

Machine Models	13
Using This Operator Manual	13
Using The Machine	13

#### **The Moffett Truck-Mounted Forklift 14**

Machine Description	14
Concept	14
Major Components	15

#### **Identifying Your Machine 17**

Machine Serial Plate	17
----------------------	----

#### **Safety Decals 18**

General	18
Safety Decals	19

#### **Instruments And Controls 29**

Dash Layout (Standard)	30
Dash Layout (MMS)	31
Transmission Controls	34
- Drive Controls	34
- Anti-Stall	35
- Automotive Pump	35
- Inching/Brake Pedal	36
Mast Controls	37
Hydraulic Control Levers	37

### 3. CENTRE OF GRAVITY

#### **Basic Principles 41**

Introduction	41
Comparison vs Conventional Forklift	43

### 4. OPERATING PROCEDURES

#### **Using The Machine 45**

Entering Operator's Compartment	45
---------------------------------	----

#### **Over Head Guard (OHG) 46**

#### **Rollover 47**

Using The Machine	48
-------------------	----

Adjusting The Seat	48
--------------------	----

Fasten The Seat Belt	48
----------------------	----

Starting The Engine	49
---------------------	----

#### **Driving Techniques 50**

Driving Forward	50
-----------------	----

Reversing	50
-----------	----

Turning	50
---------	----

Parking	50
---------	----

Operating On Inclines	51
-----------------------	----

Operating With A Load	51
-----------------------	----

Operating Without A Load	52
--------------------------	----

#### **Diff-lock 53**

Operation Of Diff-Lock	53
------------------------	----

When To Use Diff-lock	53
-----------------------	----

How To Activate Diff-lock	53
---------------------------	----

Stopping Procedure	54
--------------------	----

#### **Basic Load Techniques 55**

Travelling With A Load	55
------------------------	----

Travelling Without A Load	55
---------------------------	----

## TABLE OF CONTENTS

<b>Lifting a Load</b>		<b>Greasing</b>	
Lifting A Load From The Ground	56	Location Of Greasing Points	82
Travelling With A Cubed Load	57	<b>Engine Oil</b>	
Lifting A Wide Load	58	Oil Specification	94
Travelling With A Wide Load	59	<b>Engine Coolant</b>	
Non Palletized Or Loose Loads	60	Engine Cooling Specification	94
Lifting A Load From Above The Ground	61	<b>Engine Fuel</b>	
Double Forking	61	Engine Fuel Specification	95
<b>Lowering a Load</b>		<b>Hydraulic Fluid</b>	
Lowering A Load	62	Hydraulic Fluid Specification	96
<b>5. MOUNTING PROCEDURES</b>		<b>Chain Lubrication</b>	
<b>Introduction</b>	<b>63</b>	Chain Lubrication Specification	97
Mounting Procedure	64	<b>Grease Specification</b>	
Dismount Procedure	66	Grease Specification	97
Rules For Safe Transportation	68	<b>Tyre Inflation</b>	
<b>6. MAINTENANCE</b>		Tyre Inflation Chart	97
<b>Service Schedules</b>	<b>69</b>	<b>Noise Data</b>	
General	69	Noise	98
Introduction	70	Vibration	98
First 50 Operating Hours	71	<b>7. SPECIAL PROCEDURES</b>	
Every 200 Operating Hours	71	<b>Jump Starting</b>	<b>99</b>
Every 1000 Operating Hours	71	Safety	99
<b>Daily Maintenance</b>	<b>73</b>	Procedure	100
Interlocking Seatbelt	74	<b>8. ATTACHMENTS</b>	<b>101</b>
Daily Pre-Shift Inspection Checklist	76		
Visual Checks	76		
Operational Checks	79		
Transport Checks	81		

## TABLE OF CONTENTS

<b>B. PANTOGRAPH &amp; TELESCOPIC FORKS</b>		<b>C. MACHINE WITH 4-WAY STEERING</b>	
Pantograph & Telescopic Forks	103	Overview Of 4-Way Steering	128
<b>B1. SAFETY CHECKLIST</b>		<b>C1. SAFETY CHECKLIST</b>	
Safety Checklist	104	Safety Checklist	129
<b>B2. INTRODUCTION</b>		<b>C2. INTRODUCTION</b>	
Major Components	105	4-Way Safety Decals	130
Safety Decals	106	Instruments & Controls	131
Instruments & Controls	110	<b>C3 CENTRE OF GRAVITY</b>	
<b>B3. OPERATING PROCEDURE</b>		Centre Of Gravity- 4-Way	133
Pantograph & Telescopic Forks	113	<b>C4. OPERATING PROCEDURE</b>	
<b>B4. MOUNTING PROCEDURE</b>		Operating Procedures	135
Mounting Machine	116	Changing Steering Modes	136
<b>B5. MAINTENANCE</b>		Changing Steering Modes(MMS)	138
Grease Points	117	Lifting And Placing Wide Loads	141
		Operating On Inclines	143
		Load Supports	146
		Points To Remember	147
		<b>C5. MOUNTING PROCEDURE</b>	
		Mounting Machine	148
		<b>C6. MAINTENANCE</b>	
		Grease Points	149
		Daily Maintenance	154
		<b>C7. SPECIAL PROCEDURES</b>	
		4-Way Over Ride Procedure	155



## SAFETY NOTICES

In this Operator Manual and on the machine there are safety notices. Each notice starts with a signal word and has a specific colour. The meanings of the signal words and colours are given below.



(RED) INDICATES AN IMMEDIATE HAZARDOUS SITUATION WHICH, IF NOT AVOIDED, **WILL** RESULT IN DEATH OR SERIOUS INJURY.



(ORANGE) INDICATES A POTENTIALLY HAZARDOUS SITUATION WHICH IF NOT AVOIDED **COULD** RESULT IN DEATH OR SERIOUS INJURY.



(YELLOW) INDICATES A POTENTIALLY HAZARDOUS SITUATION WHICH, IF NOT AVOIDED, **MAY** RESULT IN MINOR OR MODERATE INJURY.



(GREEN) INDICATES THE INFORMATION IS FOR INSTRUCTION ONLY.

**Study This Operator Manual Before Starting The Machine.** You must understand and follow the instructions in this operator manual. You must observe all relevant laws and regulations. If you are unsure about anything, ask your Moffett Truck-Mounted Forklift Distributor or supervisor. **Do not guess**, you or others could be killed or seriously injured.

**Note:** You must be a trained Moffett Truck-Mounted Forklift operator to use this machine.

# 1. SAFETY INTRODUCTION

## Introduction to General Safety

This section of the Operator Manual is intended to REMIND the operator of basic safety requirements when operating industrial machinery. It is not a complete list of hazards that may exist when operating or maintaining the Moffett Truck-Mounted Forklift.

**Specific hazards relating to maintenance instructions and operating procedures are detailed in the relevant sections of this operator manual.**

### Safety First – Yours and Other Peoples

All industrial equipment can be hazardous. When a machine is properly operated and maintained, it is a safe machine to work with. But when it is carelessly operated or poorly maintained it can become a danger to you (the operator) and to others.

In this operator manual and on the machine you will find warning messages. Read and understand them. They tell you of potential hazards and how to avoid them. If you do not fully understand the warning messages, ask your supervisor or Moffett Truck-Mounted Forklift Distributor to explain them.

Safety is not just a matter of responding to the warnings. All the time you are working on or with the machine you must be thinking what hazards there might be and how to avoid them.

Do not work with the machine until you are sure you can control it. Do not start any job until you are sure that you and those around you will be safe. If you are unsure of anything, about the machine or the job, ask someone who knows. Do not assume anything.

# 1. SAFETY CHECKLIST

## General Safety



### **WARNING:**

**Operator Manual.** You and others can be injured if you operate or maintain the machine without studying this operator manual. Read the safety instructions before operating this machine. If you do not understand anything, ask your Moffett Truck-Mounted Forklift Distributor or supervisor to explain it. Keep this operator manual clean and in good condition. Do not operate the machine without an operator manual in the cab, or if there is anything on the machine you do not understand.



### **WARNING:**

**Clothing.** You can be injured if you do not wear proper clothing. Loose clothing can get caught in the machinery. Wear protective clothing to suit the job. Examples of protective clothing are: a hard hat, safety shoes, safety glasses, a well fitting overall, ear protectors and industrial gloves. Keep cuffs fastened. Do not wear a neck tie or scarf. Keep long hair restrained.



### **WARNING:**

**Care and Alertness.** All the time you are working with or on the machine, take care and stay alert. Always be careful. Always be aware of potential hazards.



### **WARNING:**

**Alcohol and Drugs.** It is extremely dangerous to operate machinery when under the influence of alcohol or drugs. Do not consume alcoholic drinks or take drugs before or while operating the machine or attachments. Be aware of medicines which can cause drowsiness.



### **CAUTION:**

**Regulations.** Obey all laws, work site and local regulations which affect you and your machine.



# 1. SAFETY CHECKLIST

## Operational Safety



### **DANGER:**

**Capacity.** Never exceed the forklift's rated capacity or the machine may become unstable and could cause serious injury or death.



### **DANGER:**

**Transport.** Do not attempt to transport the Moffett Truck-Mounted Forklift on a truck or trailer that is not equipped with a mounting kit designed and installed to Moffett Truck-Mounted Forklift specifications.



### **DANGER:**

**Stabilisers.** Never raise the stabilisers when the forks are extended with a load on.



### **DANGER:**

**Forks.** Do not permit personnel to stand on or ride on the forks as serious bodily injury could result.



### **DANGER:**

Never approach power lines with any part of the forklift as electrocution could result



### **WARNING:**

When placing a load, always place the load on a firm and level surface. The stabilisers must always be fully lowered before attempting to extend the forks. When lifting a load, the stabilisers must be fully lowered and raised only when the forks are fully retracted. When travelling without a load, the forks should be retracted fully.



### **WARNING:**

**Decals.** If you need eye-glasses for reading, make sure you wear them when reading the safety decals. Decals are strategically placed around the machine to remind you of possible hazards. Do not over-stretch or place yourself in dangerous positions to read the decals. If any decals get damaged or removed contact your supervisor, have them replaced.

## 1. SAFETY CHECKLIST

### Operational Safety (continued)



#### **WARNING:**

**Decals.** Decals on the machine warn you of particular hazards. Each decal is attached close to a part of the machine where there is a possible hazard. Read and make sure you understand the safety message before you work with or any part of the machine. Keep all decals clean and readable. Replace lost or damaged decals. The decals and their attachment points are shown on the following pages. Each decal has a part number printed beside it. Use this number to order a new decal from your Moffett Truck-Mounted Forklift Distributor.



#### **WARNING:**

**Hydraulic Pressure.** The hydraulic tank is pressurised and hydraulic oil may be hot. To avoid injury when removing cap, stop the engine and remove the cap very slowly. This will avoid spillage and prevent injury.



#### **WARNING:**

**Engine.** Never climb aboard or dismount from the machine with the engine running.



#### **WARNING:**

**Vapours.** Hot coolant, steam and vapours can severely burn. Stop the engine and allow it to cool before removing the radiator cap. When removing the radiator cap, turn it very slowly to allow the pressure to release.



#### **WARNING:**

**Transport.** Do not attempt to transport the Moffett Truck-Mounted Forklift unless you have read the transport section of the manual very carefully!



#### **WARNING:**

**Seat Belt.** If the seat belt does not 'lock' when fastened do not drive the machine. The seat belt assembly must be replaced immediately.

## 1. SAFETY CHECKLIST

### Operational Safety (continued)



#### **WARNING:**

##### **Seat Belt.**

- Failure to properly inspect & maintain the seat belt can cause serious injury or loss of life in an accident.
- Any time the Moffett Truck-Mounted Forklift is being operated and is involved in an accident replace the whole seatbelt assembly.
- If the seatbelt is worn or damaged it must be replaced.
- The seatbelt must be inspected at least once a year and more often if exposed to harsh conditions.
- If replacement of any part of the seatbelt is required then the entire assembly must be replaced (Retractor and Buckle) with Moffett Engineering Ltd. recommended items from a service provider.



#### **WARNING:**

**Seat Belt.** The operator's enclosure is designed to give you protection in an accident. If you do not wear your seat belt you could be thrown out of the machine and crushed. You must wear a seat belt when using the machine. Fasten the seat belt before starting the machine.



#### **WARNING:**

**Safety.** Always wear your seatbelt when driving the Moffett Truck-Mounted Forklift. The forklift may tip over if operated incorrectly. To protect the operators from the risk of serious injury or death in the event of a tip over, it is best to be held securely in the seat. The seat and seatbelt will help keep you safely within the operator's compartment. In the event of a tip over, DO NOT JUMP. Grip the steering wheel, brace your feet, lean away from the direction of tip-over and stay within the operator's compartment.



#### **WARNING:**

**Loose Articles.** Do not leave loose articles in the drivers compartment loose articles can fall and strike you, or roll on the floor. You could be knocked unconscious, or the controls could get jammed. If that happens you could lose control of the machine.

## 1. SAFETY CHECKLIST

### Operational Safety (continued)



#### **WARNING:**

**Engine Damage.** Do not use starting fluid or spray as these are highly flammable, corrosive and cause engine damage.



#### **WARNING:**

**Procedure.** Never leave the operator's seat without first:

- Facing the machine uphill and turning the rear wheel sideways if stopped on an incline.
- Engaging the park brake.
- Lowering the forks to the ground.
- Placing all controls in the neutral position.
- Stopping the engine.
- Removing the key.



#### **WARNING:**

**Machine Condition.** A defective machine can injure you or others. Do not operate a machine which is defective or has missing parts. Make sure the maintenance procedures in this operator manual are completed before using the machine.



#### **WARNING:**

**Visibility.** Accidents can be caused by working in poor visibility. Use the work lights on the machine to improve visibility. Do not operate the machine if you cannot see properly.



#### **WARNING:**

**Loading.** Before attempting to load a truck or trailer, chock the wheels of the truck/trailer to prevent it moving. Always lower the stabilisers fully before attempting to pick-up a load from a truck or trailer.



#### **WARNING:**

**Practice.** You or others can be killed or seriously injured if you do unfamiliar operations without first practicing them. Practice away from the work site on a clear area. Keep other people away. Do not perform new operations until you can do them safely.

## 1. SAFETY CHECKLIST

### Operational Safety (continued)



#### **WARNING:**

**Controls.** You or others can be killed or seriously injured if you control the machine from outside the drivers compartment. Operate the control levers only when you are correctly seated inside the driver's compartment with seatbelt fastened.



#### **WARNING:**

**Controls.** If the Forward/Reverse pedal does not return to the neutral position, do NOT use the machine and contact your supervisor.



#### **WARNING:**

**Passengers.** Passengers in or on the machine can cause accidents. The Moffett Truck-Mounted Forklift is a one man machine. Do not carry passengers.



#### **WARNING:**

**Telescopic Legs.** The telescopic legs should only be retracted when necessary for truck mounting the machine for transport, and should be extended fully before attempting to operate the machine.



#### **CAUTION:**

**Hydraulic Function.** Never continue to operate a hydraulic function lever after the function has reached the end of its travel.



#### **CAUTION:**

**Hydraulic Pressure.** It is important to pressurise the machine down onto the sliding boxes before turning off the engine to ensure that the machine is held tight against the mounting kit supports and thus preventing the machine from being able to move while in transport. Stabilising chains are used only as a back up and should remain loose.



#### **CAUTION:**

**Diff-lock.** Use the diff-lock only while travelling in a straight line.

## 1. SAFETY CHECKLIST

### Operational Safety (continued)



#### CAUTION:

**Rear Bumper.** The rear bumper must be folded back out to full length and the locking pin and lynch pin fitted when the forklift is not being transported or removed for the purposes of loading or unloading.



#### CAUTION:

**Safe Operation.** If something comes loose, breaks or fails to operate:

- Stop.
- Apply the park brake.
- Shut down the engine.
- Get it repaired.



#### CAUTION:

**Wide Loads.** When carrying wide or tall loads your visibility may be blocked by the load. It may be safer to travel in reverse when moving with such loads. You may require a signal person or "spotter" to guide you. Do not drive uphill in reverse. If the street lights are blocked by the load the work lights must be used to improve visibility and ensure you are seen by other road users.



#### CAUTION:

**Mounting.** When truck mounting do not use the reach device. Mount the machine as outlined in the normal mounting procedure as explained in section B5.



#### CAUTION:

**Temperature.** Always turn off the engine and allow it to cool before checking:

- Engine coolant level
- Engine oil level
- Hydraulic oil level



#### WARNING:

**Working Environment:** Remember that rain, snow, ice, mud, loose gravel and uneven or soft ground could change the operating capabilities and could cause you to lose control or cause the forklift to tip over.

## 1. SAFETY CHECKLIST

### Maintenance Safety



#### **WARNING:**

**Raised Attachments.** Raised attachments can fall and injure you. Do not walk or work under raised attachments unless they are safely blocked.



#### **WARNING:**

**Raised Machine.** NEVER position yourself or any part of your body under a raised machine which is not properly supported. If the machine moves unexpectedly you could become trapped and suffer serious injury or be killed.



#### **WARNING:**

**Soft Ground.** A machine can sink into soft ground. Never work under a machine on soft ground.



#### **WARNING:**

**Lifting Equipment.** If you are using lifting equipment to lift or repair your machine, you can be injured. Make sure that the lifting equipment is in good condition. Make sure that lifting tackle complies with all local regulations and is suitable for the job. Make sure that lifting equipment is strong enough for the job.



#### **WARNING:**

**Repairs.** Do not try to do any repairs or any other type of maintenance work you do not understand. Moffett Truck-Mounted Forklift Engineers have been trained in all aspects of the Truck-Mounted Forklift.



#### **WARNING:**

**Hydraulic Fluid.** Fine jets of hydraulic fluid at high pressure can penetrate the skin. Do not use your fingers to check for hydraulic fluid leaks. Do not put your face close to suspected leaks. Hold a piece of cardboard close to the suspected leaks and then inspect the cardboard for signs of hydraulic fluid. If hydraulic fluid penetrates your skin, seek medical attention immediately.



#### **WARNING:**

**Hydraulic Pressure.** Hydraulic fluid at pressure can injure you. Make the machine safe before connecting or disconnecting couplings; lower the payload to the ground, stop the engine then operate the hydraulic controls a few more times to vent residual hydraulic pressure from the system.

## 1. SAFETY CHECKLIST

### Maintenance Safety (continued)



#### **WARNING:**

**Hydraulic Hoses.** Damaged hoses can cause fatal accidents. Inspect the hoses regularly for:

- Damaged end fittings
- Chafed outer covers
- Ballooned outer covers
- Kinked or crushed hoses
- Embedded or armoring in outer covers
- Displaced end fittings.



#### **WARNING:**

**Metal Splinters.** You can be injured by flying metal splinters when driving pins in or out. Use a soft faced hammer or drift to remove and fit metal pins. Always wear safety glasses.



#### **WARNING:**

**'O' Rings, Seals and Gaskets.** Badly fitted, damaged or rotted 'O' rings, seals and gaskets can cause leakages and possible accidents. Renew whenever disturbed, unless otherwise instructed. Do not use Trichloroethane or paint thinners near 'O' rings and seals.



#### **WARNING:**

**Electrical Circuits.** Understand the electrical circuit before connecting or disconnecting an electrical component. A wrong connection can cause injury and/or damage.

Do not disconnect the battery when the machine is running otherwise the electrical circuits may be damaged.



#### **WARNING:**

**Communications.** Bad communications can cause accidents. If two or more people are working on a machine, make sure each knows what the others are doing. Before starting the engine make sure others are clear of the danger areas; examples of the danger areas are: the rotating blades and belt on the engine, the attachments and linkages, and anywhere beneath or behind the machine. People can be killed or injured if these precautions are not taken.



## 1. SAFETY CHECKLIST

### Maintenance Safety (continued)



#### **CAUTION:**

**Cleaning.** Cleaning metal parts with incorrect solvents can cause corrosion. Use only recommended cleaning agents and solvents.



#### **CAUTION:**

**Machine Modifications.** This machine is manufactured in compliance with legislative and other requirements. It should not be altered in any way which could affect or invalidate any of the requirements. For advice contact your Moffett Truck-Mounted Forklift Distributor



#### **CAUTION:**

**Welding.** Before carrying out any welding on the machine, disconnect the battery and alternator to protect the circuits and components.

The battery must still be disconnected even if a battery isolator is fitted.

Make sure the welding path is kept as short as possible. This prevents high currents being induced into the machine frame or wiring harness.

## 2. INTRODUCTION

### About This Operator Manual

#### Machine Models.

This operator manual provides information for the Static Mast Range of Moffett Truck-Mounted Forklifts.

#### Using This Operator Manual.

The illustrations in the operator manual are for guidance only. Where machines differ, the text and/or illustration will specify.

This operator manual is arranged to give a good understanding of the machine and its safe operation. It also contains maintenance information and specification data. Read this operator manual from front to back before using the machine for the first time. Particular attention must be given to all the safety aspects of operating and maintaining the machine.

General warnings in this chapter are repeated throughout this manual as well as specific warnings. Read all the safety statements regularly, so you don't forget them. Remember that the best operators are the safest operators.

Finally, treat this operator manual as part of the machine. Keep it clean and in good condition and ensure it is always located in the operator manual box on the back of the seat.

If there is anything you are unsure about ask your supervisor or Moffett Truck-Mounted Forklift Distributor. Do not guess, you or others could be killed or seriously injured.

The manufacture's policy is one of continuous improvement. The right to change the specification of the machine without notice is reserved.

No responsibility will be accepted for discrepancies which may occur between the specifications of the machine and the descriptions contained in this publication.

#### Using The Machine.

To use the Moffett Truck-Mounted Forklift efficiently and safely you must know the machine, and be trained and authorized to use it.

This Operator Manual is intended to familiarise you on the machine, its controls and its safe operation. It is not intended or suitable for use as a training manual for an inexperienced operator.

## 2. INTRODUCTION

### The Moffett Truck-Mounted Forklift Machine Description.

The Moffett Truck-Mounted Forklift is a three wheeled, non-counterbalanced forklift capable of being transported on the rear of a truck or trailer. Its short turning radius and rear wheel steer make it extremely manoeuvrable in confined spaces. The forklift is equipped with forks that can move in and out or pantograph scissor reach. The mast is fitted with a double acting lift cylinder which means a load can be lifted on the forks by the full bore side of the cylinder but also that the machine can be lifted for truck mounting using the rod side of the cylinder.

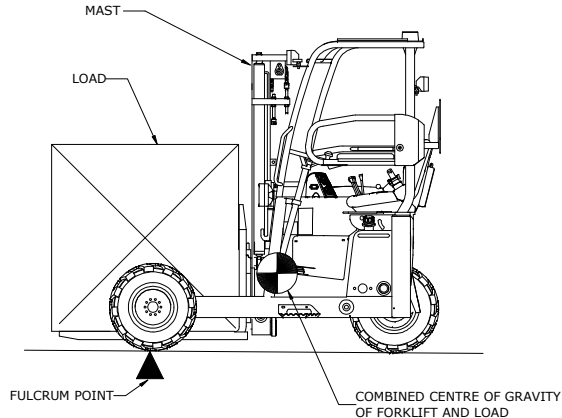

### Concept

Unlike a conventional forklift the Truck Mounted Forklift does not have a counterweight at the rear, instead it uses its own weight to counter the load. Normally the front fulcrum for the machine is located under the front tyre. By lowering stabilisers this fulcrum is moved forward and with the forks extended this allows the forklifts weight to counter the capacity to be lifted. Once the load has been picked then the forks are retracted bringing the load into the frame of the forklift. At this stage the stabilisers can be raised and the machine can travel with the load.

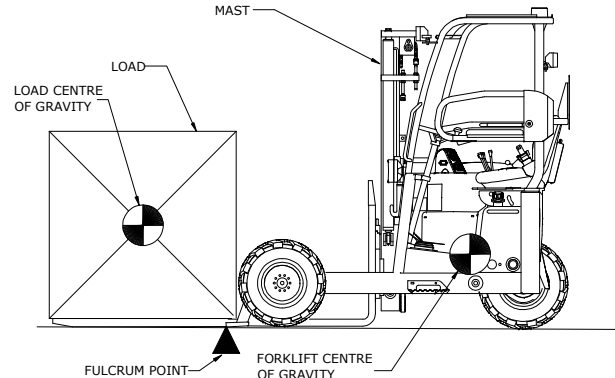

## 2. INTRODUCTION

### Major Components

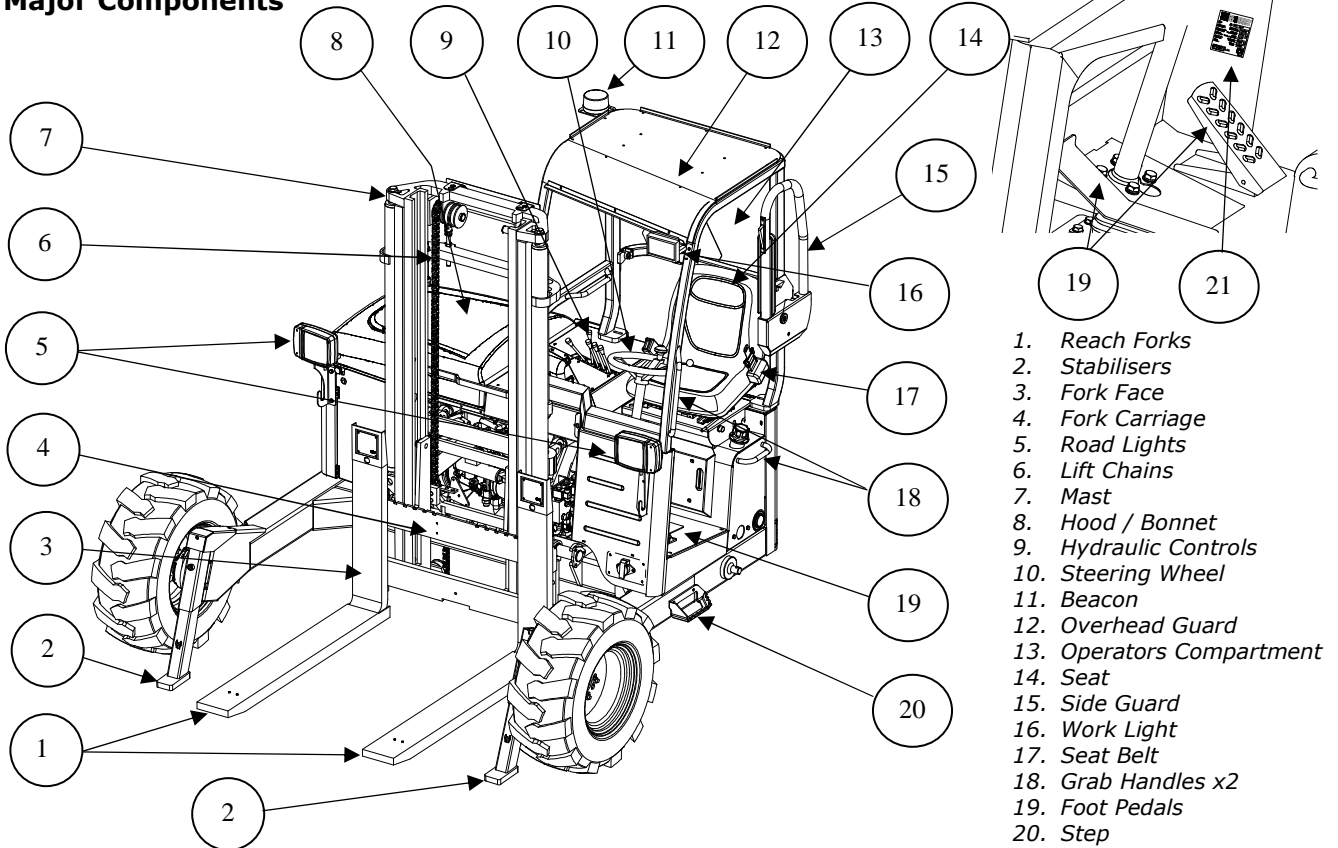

## 2. INTRODUCTION

### Major Components (continued)

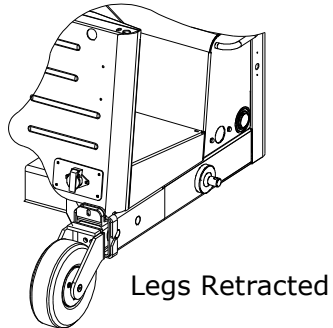
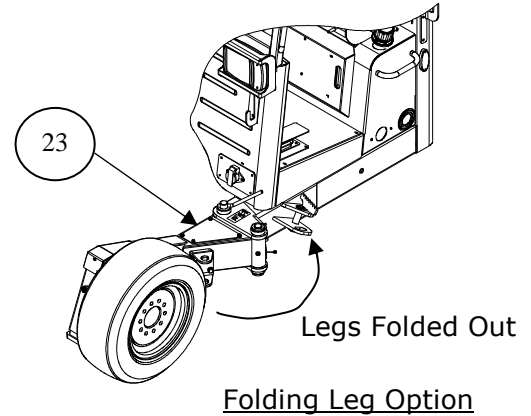
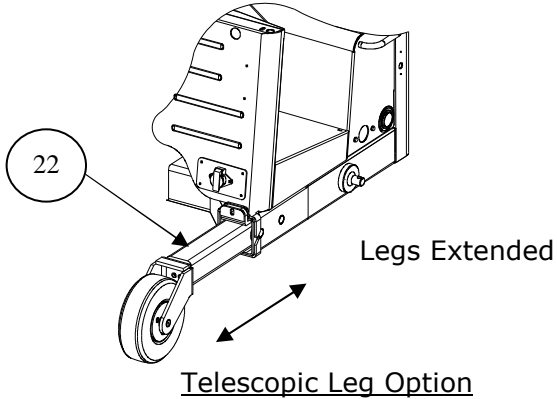

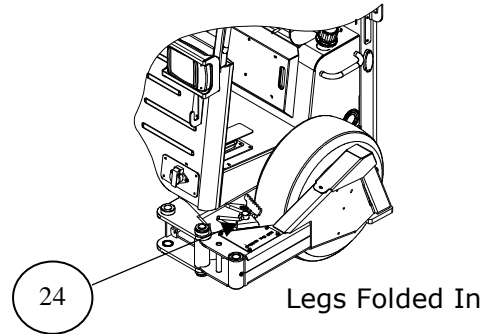

- 22. *Telescopic Legs*
- 23. *Folding Legs*
- 24. *Folding Leg Locking Pin*



## 2. INTRODUCTION

### Identifying Your Machine

- Serial Plate:** This is located in the driver's compartment and it gives the following information:
- Type:** This is the machine model. i.e. M4 (example shown).
- Serial No:** This is a unique number given to all machines.
- Rated Capacity:** The rated lifting capacity of the machine.
- Year Of Make:** The date of manufacture of the machine
- Dead Mass:** The gross weight of the machine.

		<b>MOFFETT</b>
Type :	Type :	M4 25.3
Serialnummer :	Seriennummer :	113536
Serial number :	Numeró de série :	
Nominale capaciteit :	Nennleistung :	2500 kg
Rated capacity :	Capacité nominale :	
Bouwjaar :	Baujahr :	14-07
Year of make :	Année construction :	
Eigen massa :	Eigenmasse :	2250 kg
Dead mass :	Masse vide :	
Versie :	Version :	0269
Version :	Version :	
LEIJESTER HEGEDYK 25 9071 XB OUDE LEIJE (NL) www.hiab.com		 951.622

## 2. INTRODUCTION

### Safety Decals

#### General



#### **WARNING:**

If you need eye-glasses for reading, make sure you wear them when reading the safety decals. Decals are strategically placed around the machine to remind you of possible hazards. Do not over-stretch or place yourself in dangerous positions to read the decals.



#### **WARNING:**

Decals on the machine warn you of particular hazards. Each decal is attached close to a part of the machine where there is a possible hazard. Read and make sure you understand the safety message before you work with or around any part of the machine.

Keep all decals clean and readable. Replace lost or damaged decals. The decals and their attachment points are shown on the following pages. Each decal has a part number printed beside it. Use this number to order a new decal from your Moffett Truck-Mounted Forklift Distributor.

Part No. 517.100.0077

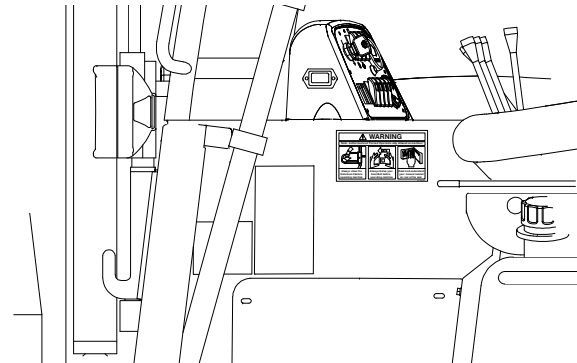
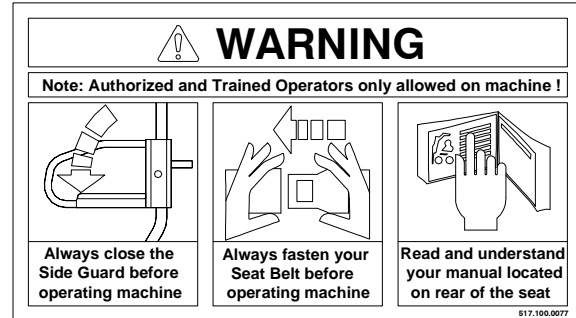

## 2. INTRODUCTION

### Safety Decals (continued)

Part No. 517.055.0006

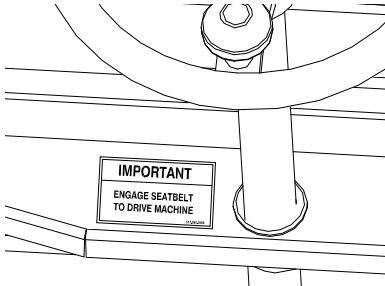
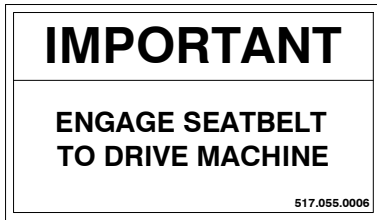

Part No. 517.056.0115

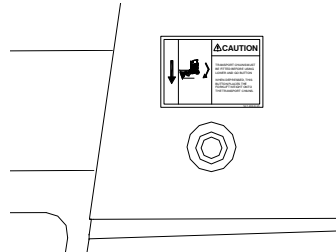
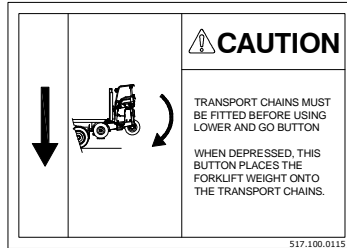

**Note:** Lower and Go only works when ignition key is in the off position.

Part No. 517.100.0140

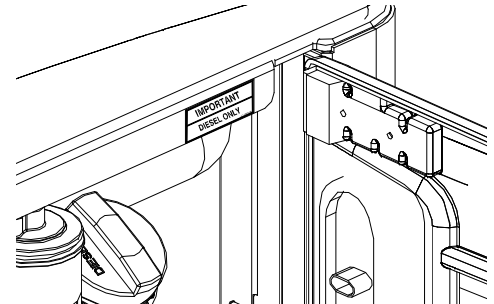



## 2. INTRODUCTION

### Safety Decals (continued)



#### **DANGER:**

Do not permit personnel to stand on or ride on the forks or load as serious bodily injury could result.

**Part No. ENG002**

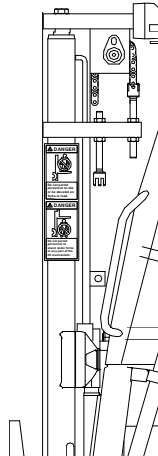
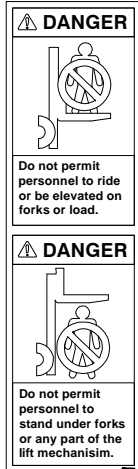

**Part No. 517.130.0003**

## INSTRUCTIONS

#### **DO NOT OPERATE THIS MACHINE UNLESS:**

- You have read and understand the safety and operating instructions contained in the operator manual and viewed the Moffett Truck-Mounted Forklift Operator Training Video.
- You have been trained in the safe operation of the Moffett Truck-Mounted Forklift.
- You have checked your machine and all functions are operating correctly.

#### **WHEN TRAVELLING WITHOUT A LOAD:**

- Keep the mast fully forward and the forks as low as possible. (moving mast)
- Keep the reach device retracted and as low as possible. (static mast)
- Center the fork carriage using the side-shift function.

#### **WHEN TRAVELLING WITH A LOAD:**

- Keep the forks fully retracted and the load as low as possible. (moving mast)
- Keep the reach device fully retracted and the load as low as possible. (static mast)
- Make all turning manoeuvres slowly and carefully. Do not stop suddenly.
- Travel with the load side-shifted to the center position.

#### **WHEN TRAVELLING ON INCLINES:**

- Travel directly up or down, do not travel across an incline.
- Keep the forks facing uphill at all times.
- Engage the stiff-lock if operating on slippery slopes.
- Keep the load as low as possible. Do not elevate the load.

#### **WHEN LIFTING A LOAD:**

- Check that the stabilizers are fully lowered on a firm and stable surface.
- Do not raise the stabilizers unless the forks are fully retracted. (moving mast)
- Do not raise the stabilizers unless the reach device is fully retracted. (static mast)

#### **WHEN PLACING A LOAD:**

- Do not extend the forks forward unless the stabilizers are fully lowered on a firm and stable surface. (moving mast)
- Do not extend the reach device forward unless the stabilizers are fully lowered on a firm and stable surface. (static mast)
- Check that the forks are fully engaged and centered in the mounting kit before raising the forklift.

#### **WHEN MOUNTING FOR TRANSPORT:**

- Check that the forks are fully engaged in the mounting kit before raising the forklift.

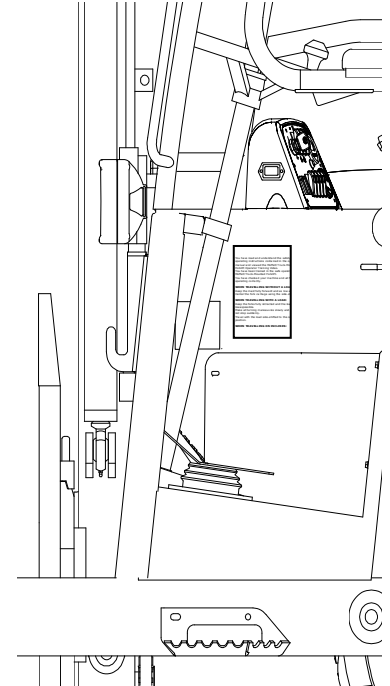

## 2. INTRODUCTION

### Safety Decals (continued)





Part No.517.130.0001

Part No. Eng003

### MOUNTING INSTRUCTIONS

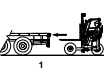
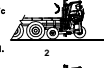
**TO MOUNT THE MACHINE ON A TRUCK/TRAILER**

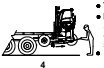
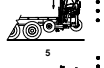
- Approach the truck/trailer with the forks fully retracted.
- Locate the forks between the fork supports.
- Drive into truck/trailer fully.
- Retract the telescopic leg (if fitted).
- Tilt the most rearward fully to raise the rear wheel.
- Lower the forks to raise the machine using the lift lever until the bottom of the main crossmember of the machine is slightly higher than the sliding supports.

- Turn off engine.
- Dismount using the 3-point contact method and carefully extend the sliding supports.
- Climb aboard the machine using the 3-point contact method.
- Fasten seat belt.
- Start the engine.
- Raise the forks to pressurize the machine down on the sliding supports.
- Turn off the engine.
- Dismount from the machine using the 3-point contact method.
- Connect auxo cable and attach the safety chains.
- Check all transport lights function properly.

**TO DISMOUNT THE MACHINE FROM A TRUCK/TRAILER**



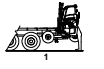
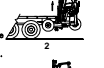
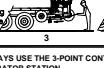
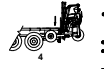
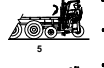
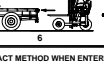



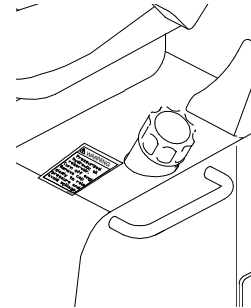
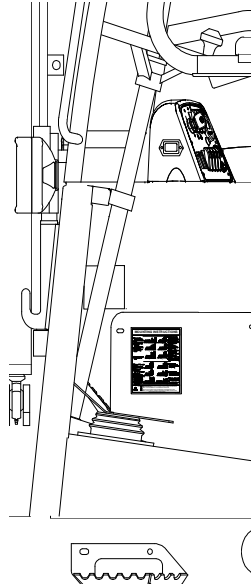

- Disconnect the safety chains and the auxo cable.
- Climb aboard the machine using the 3-point contact method.
- Close the side guard fully.
- Start the engine.
- Raise the machine off the sliding supports and tilt the mast rearward.
- Turn off the engine.
- Dismount using the 3-point contact method.
- Retract the mounting kit supports into the guides provided.
- Remove both slackened transport chains and place them in the hooks provided.
- Climb aboard using the 3-point contact method.
- Fasten the seat belt.
- Raise the forks to lower the machine to the ground.
- Raise the forks slightly to pressurize the lift cylinder and clear the fork traces.
- Back up slowly until the forks are clear of the mounting kit.
- Extend the telescopic legs (if fitted).

**NOTE:**

- ALWAYS USE THE 3-POINT CONTACT METHOD WHEN ENTERING OR EXITING THE OPERATOR STATION.
- ENSURE THE PARKING BRAKE IS DISENGAGED IN TRANSPORT.
- ENSURE THE FOLDING DOT BUMPER IS EXTENDED AND PINNED ON BOTH SIDES
- WHEN THE MACHINE IS NOT MOUNTED.

517.130.0001



### WARNING

Pressurized hydraulic oil reservoir. Turn off engine. Remove cap slowly to release pressure and avoid spillage.

ENG003



### WARNING:

The hydraulic tank is pressurised and hydraulic oil may be hot. To avoid injury when removing cap, stop the engine and remove the cap very slowly. This will avoid spillage and prevent injury.

## 2. INTRODUCTION

### Safety Decals (continued)

Part No. 517.100.0140

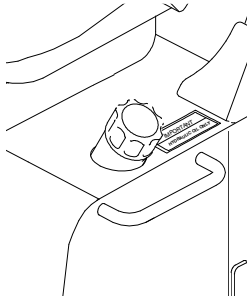

Part No. 517.120.0000

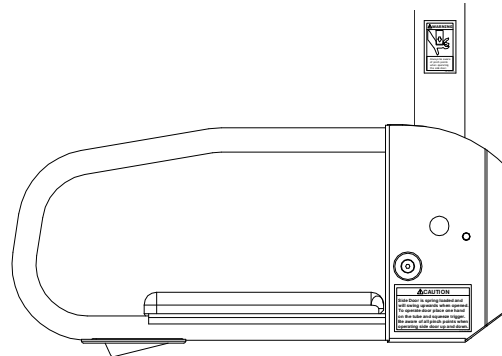
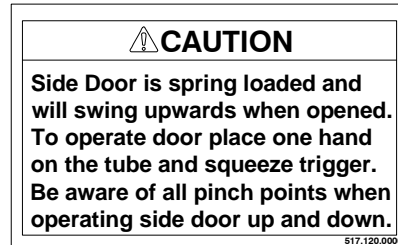

Part No. 517.120.0001

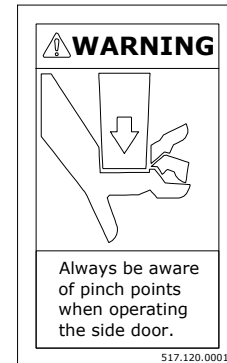

## 2. INTRODUCTION

### Safety Decals (continued)

Part No. Eng004

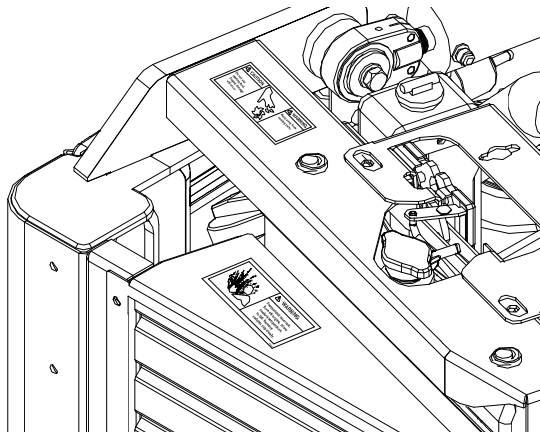
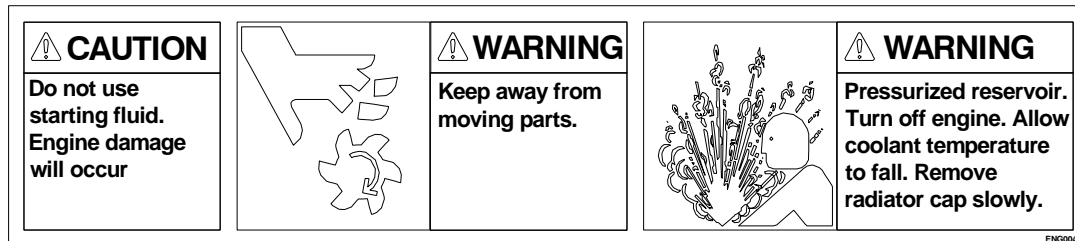

### **WARNING:**

Hot coolant, steam and vapours can severely burn. Stop engine and allow it to cool before removing the radiator cap. When removing the radiator cap, turn it very slowly to allow the pressure to release.

## 2. INTRODUCTION

### Safety Decals (continued)

Part No. Eng010

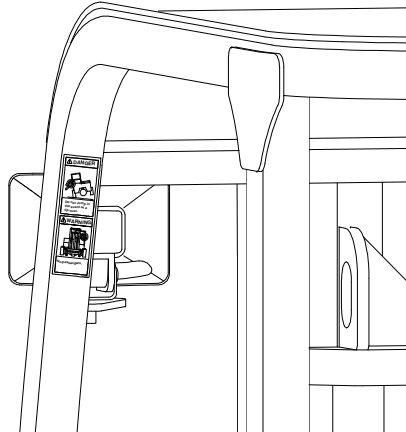

**Note:** This machine is fitted with an interlocking seatbelt. The machine will not drive unless the seatbelt is engaged.

Part No. ENG019

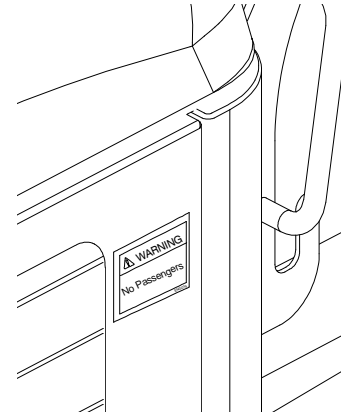

## 2. INTRODUCTION

### Safety Decals (continued)

Part No. ENG011

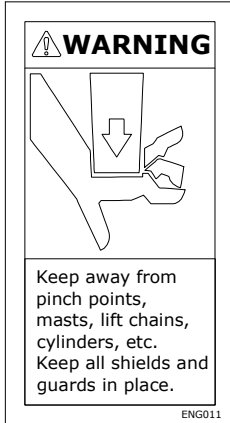

**Note:** Location of pinch points decals P.N. – ENG011 on stabilisers, sideshift cylinder, telescopic legs & folding legs

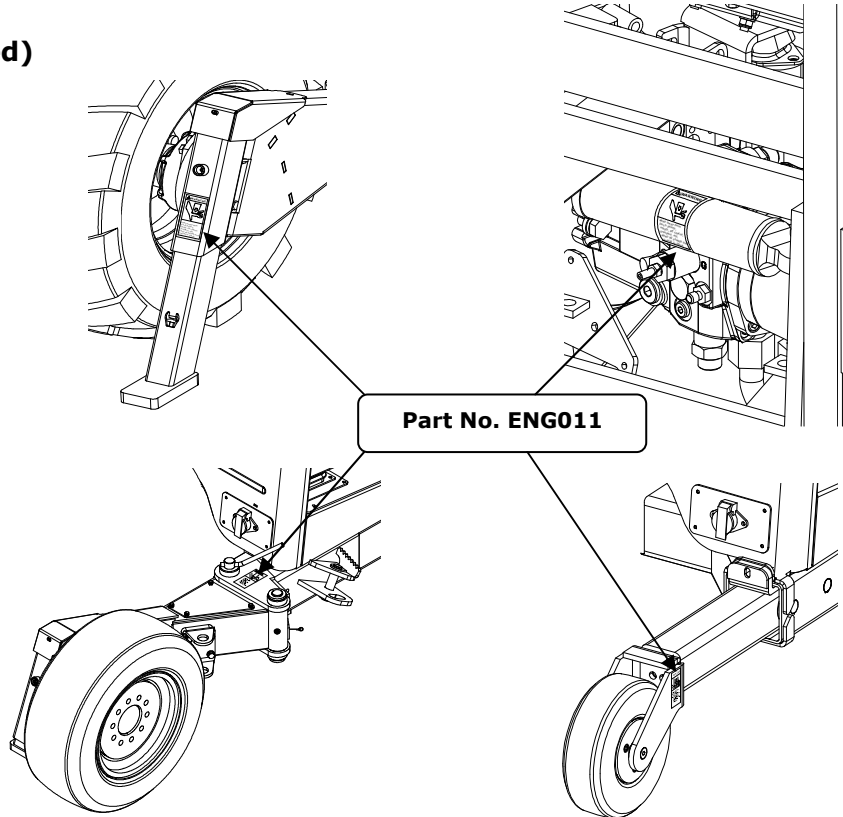

## 2. INTRODUCTION

### Safety Decals (continued)

Part No. 517.130.0004

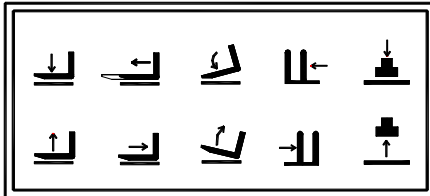

Part No. 517.130.0005

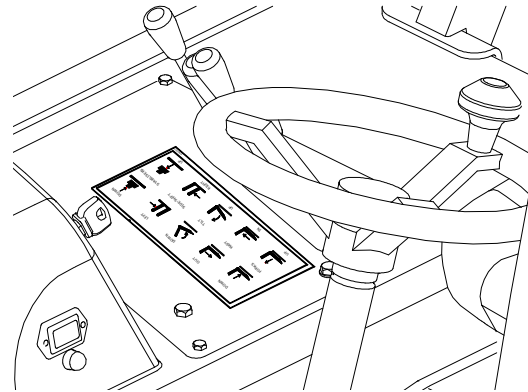
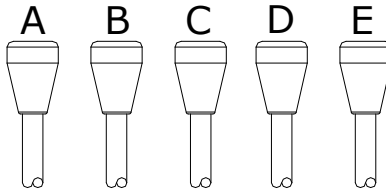
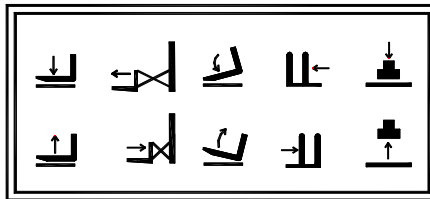

## 2. INTRODUCTION

### Safety Decals (continued)

**Note:** When replacing decals always ensure correct part number is supplied

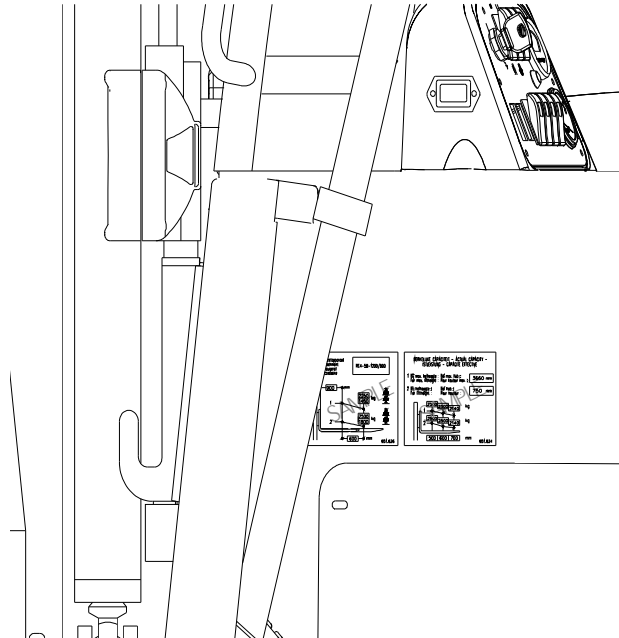
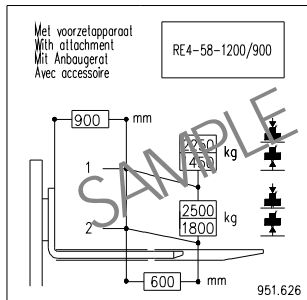
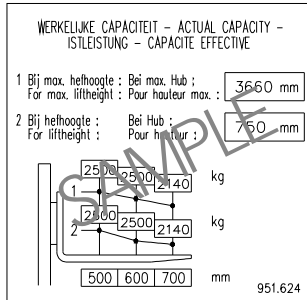



## 2. INTRODUCTION

### Safety Decals (continued)

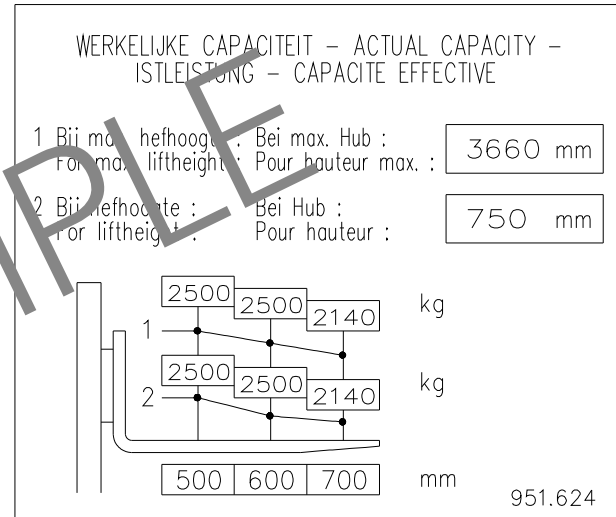
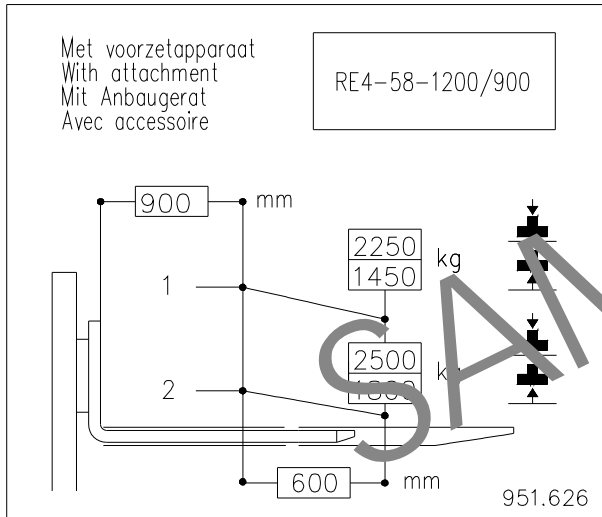

## 2. INTRODUCTION

### Instruments and Controls

The Moffett Truck-Mounted Forklift is provided with a set of controls to enable you to operate the machine safely and efficiently.

The instruments and controls are in the following groups:

- A** Forward/Reverse Pedal
- B** Throttle
- C** Side Guard
- D** Starter Reset
- E** Hour Meter
- F** Dash Panel
- G** Steering Wheel
- H** Hydraulic Controls
- I** Switches
- J** Ignition Switch
- K** Warning Lights
- L** Park Brake
- M** Manual Box

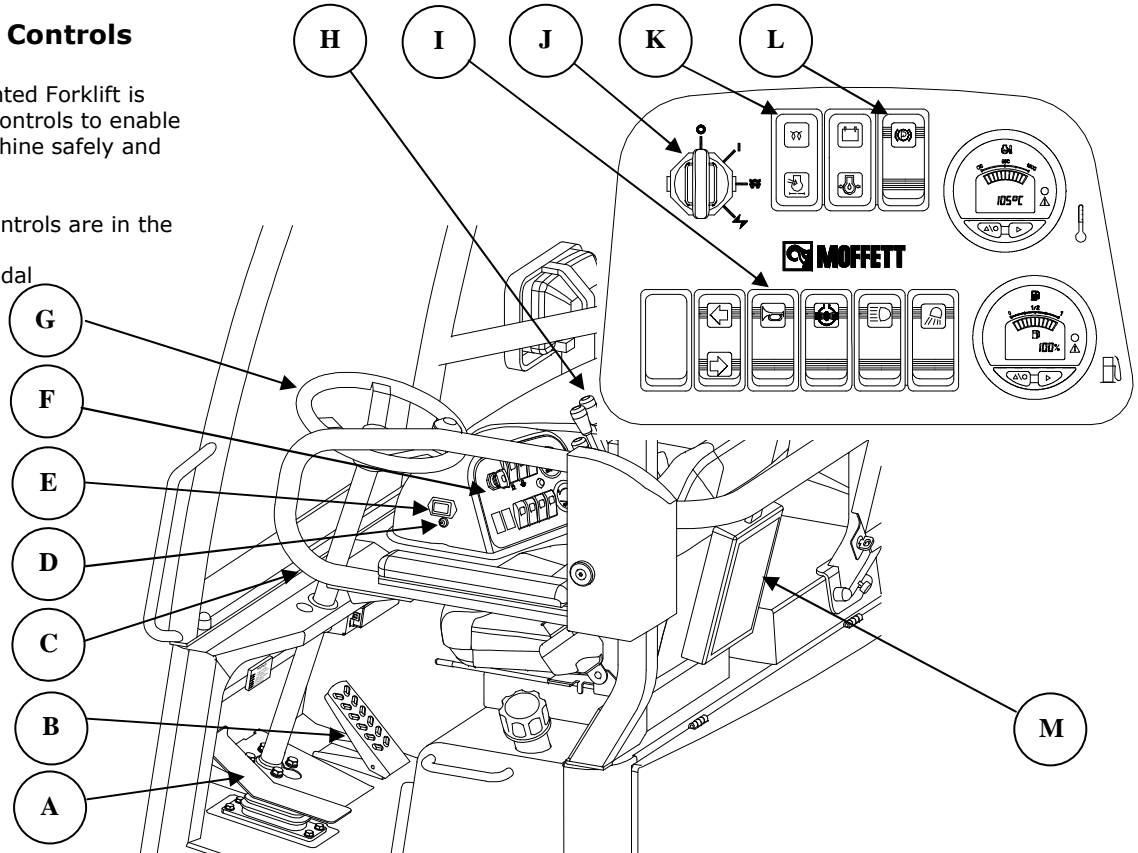





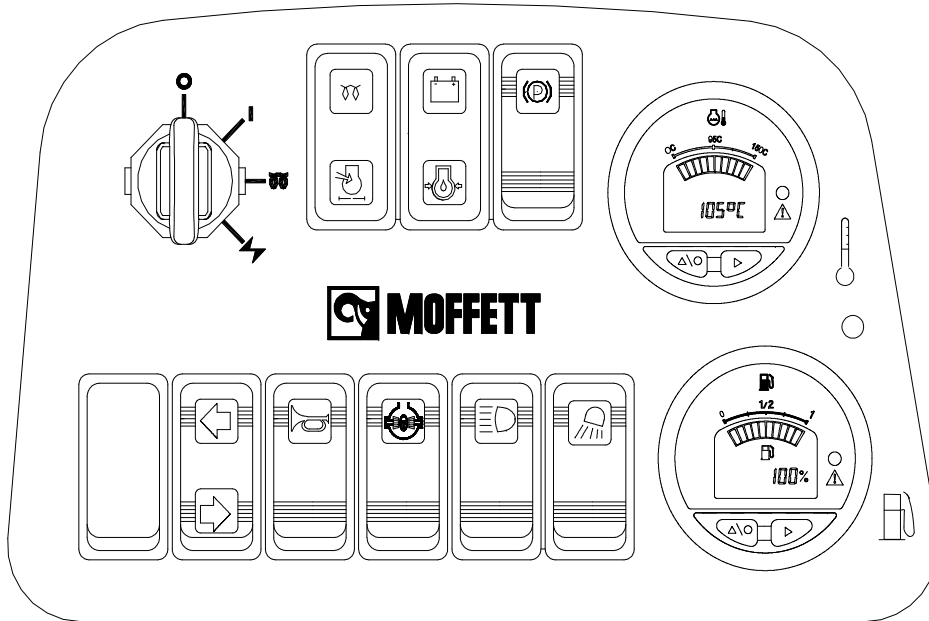





## 2. INTRODUCTION

### Instruments And Controls (continued)



**Note:** 4-Way dash configuration section C2

-  **Engine Preheater**
-  **Air Filter Blockage**
-  **Battery (No Charge)**
-  **Engine Oil Pressure Low**
-  **Park Brake Engaged**
-  **Indicators**
-  **Horn**
-  **Difflock Engaged**
-  **Main Beam**
-  **Work Lights**

## 2. INTRODUCTION

### Instruments And Controls MMS

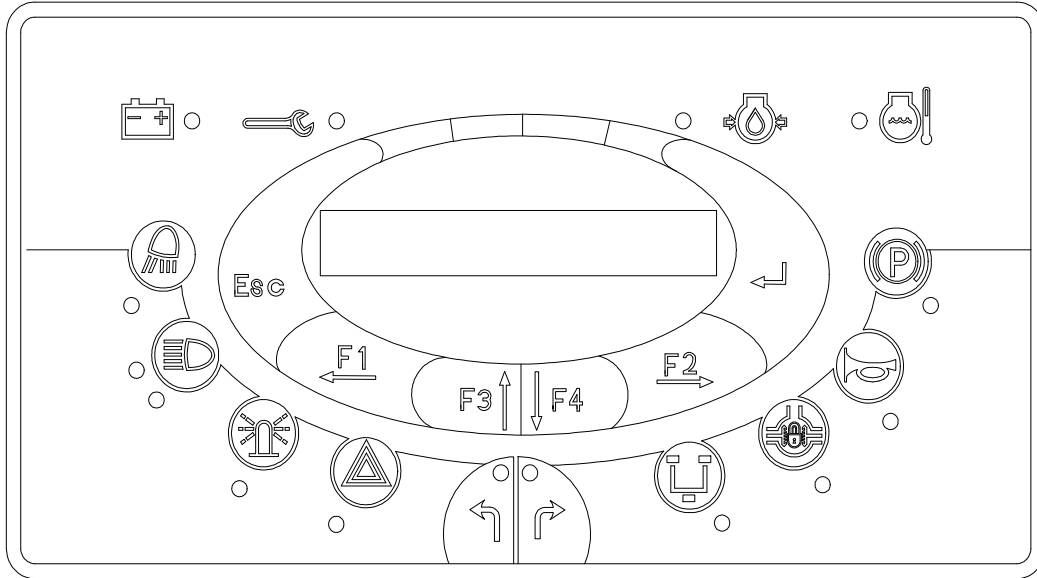

-  **Battery (No Charge)**
-  **Service Warning**
-  **Work Lights**
-  **Main Beam**
-  **Flashing Beacon**
-  **Hazard**
-  **Indicators**
-  **4-Way**
-  **Difflock**
-  **Horn**
-  **Park Brake**
-  **Oil Pressure**
-  **Engine Temperature**

- Esc** **Escape (Exits selected menu)**
- F1** **Select Left**
- F2** **Select Right**
- F3** **Select Up**
- F4** **Select Down**
- Return** **Return (Accept selected menu)**

## 2. INTRODUCTION

### Instruments And Controls (continued)

#### ESC

The MMS display goes one screen back in the menu or exits the selected menu completely.

#### Return

Confirming the selection by one of the function keys in the menu. Not pushing this key means that any changes are **not** being saved after pushing the key.

#### F1

Selecting a menu option or moving the cursor to the left.

#### F2

Selecting a menu option or moving the cursor to the right.

#### F3

Scrolling up in the menu or increasing the value above the cursor.

#### F4

Scrolling down in the menu or decreasing the value above the cursor.

#### Work Lights

Work lights should be used on site when visibility is poor. They may also be used to improve visibility if the road lights are blocked while carrying a load.

#### Street Lights

Street lights should be used when travelling on a public highway.

**Note:** Dip beam should always be used when approaching other users of the highway.

#### Flashing Beacon

The Moffett Truck-Mounted Forklift is fitted with a flashing beacon. The beacon is activated when the ignition is turned to the ON position. If the beacon fails to work when the machine is turned ON, do not operate the machine. Contact your supervisor.

#### Hazzard Lights

The hazard lights are used to warn other drivers if your vehicle must be stopped where it might be a traffic hazard.

#### Indicators

The indicator switch is located on the dash panel.

## 2. INTRODUCTION

### Instruments And Controls (continued)

#### 4-Way

When activated this turns the machine into 4-Way mode. Pressing the button again returns the machine to 2-Way.

#### Diff-Lock

When activated this transfers equal flow to all 3 wheels to improve traction.

#### Horn

The horn is used to alert people of your manoeuvres.

#### Park Brake

The park brake should be engaged when the forklift is parked.

**Note:** If Seatbelt is not connected then Park Brake is automatically applied. Ensure that seatbelt is applied when truck mounting.

#### Hour Meter

Indicates the engine operating hours.

#### Water Gauge

The water gauge is used to display the operating temperature of the engine.

#### Fuel Gauge

The fuel gauge indicates the amount of fuel in the fuel tank.

#### Starter Reset

The starter reset, is a thermostatic trip switch that prevents the starter motor from over heating. If this trips wait 30 seconds push the reset button and retry starting the machine.

## 2. INTRODUCTION

### Transmission Controls

The machine can be fitted with the following drive control options:

1. **“Anti Stall” Pump** – Control comprises:  
Hydraulic Foot operated Forward / Reverse Pedal  
Foot operated Accelerator pedal
2. **“Automotive” Pump** – Control comprises:  
Column Shift Forward / Reverse lever  
Foot operated “inching/brake” pedal  
Foot operated Accelerator pedal

#### Accelerator Pedal – Engine RPM

This pedal is pressed down to increase engine RPM. It should be used to keep the engine at a constant RPM and should not be used to adjust the travel speed of the machine. The engine RPM also affects the speed of the hydraulic functions.

#### Forward/Reverse Pedal – Travelling Speed

This pedal controls the forward and reverse movement of the machine. The machine will not move if you do not press the hydraulic pedal. Depress the pedal(toe) forward to move the machine forward. Depress the pedal(heel) back to move the machine in reverse. By returning the pedal to mid-point (neutral) the machine will stop. This pedal is also used to control the

speed of the machines movement. The further the pedal is pressed in either direction, the faster the machine will travel. When travelling on gradients or on rough terrain, forward/reverse pedal movement should be reduced and engine RPM increased.



#### **WARNING:**

If forward/reverse pedal does not return to neutral do not use the machine and contact your supervisor.

**Forward/Reverse Pedal**

**Accelerator Pedal**

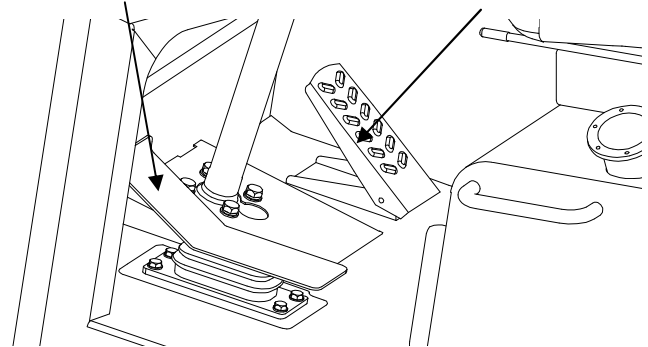

## 2. INTRODUCTION

### Transmission Controls (continued)

#### 1. Anti-Stall Pump – Hydraulic Foot-Pedal Control.

The Anti Stall hydrostatic drive pump greatly enhances smooth, slow travel which is important when operating with large or long loads.

When driving the operator controls the speed and torque using the accelerator pedal only, while keeping the forward/reverse pedal fully depressed in the direction of travel.

This capability is due to the pump being able to sense the engine load and self-adjust to the conditions accordingly (similar to an automatic transmission in an automobile where you do not need to shift up or down).

#### 2. Automotive Pump – Column Shift Control.

With automotive control the Moffett Truck-Mounted Forklift is equipped with two foot pedals and column mounted forward/reverse hand lever. The right pedal is the accelerator pedal which controls both engine RPM and speed of travel. The left pedal is the “inching/brake” pedal which is used to stop the machine or move the machine slowly.

**Note:** The engine will not start unless the forward/reverse lever is in the neutral position while turning the key.

#### Forward / Reverse Lever

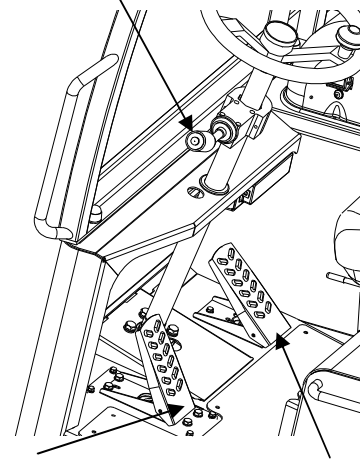

#### Inching / Brake Pedal

#### Accelerator Pedal

The accelerator pedal is used to control both engine RPM and speed of travel of the machine. The accelerator pedal regulates RPM but will not move the machine until the forward/reverse hand lever is activated.



## 2. INTRODUCTION

### Transmission Controls (continued)

#### Operation

**TO MOVE THE MACHINE FORWARD** – Move the forward/reverse lever to the forward position and depress the accelerator pedal – the machine will move forward.

**TO MOVE THE MACHINE BACKWARD** – Move the forward/reverse lever to the backwards position and depress the accelerator pedal – the machine will move backwards.

**TO STOP THE MACHINE** – Release the accelerator pedal and the machine will stop. Alternatively, depressing the “inching/brake” pedal fully will stop the machine more quickly.

**Note:** The higher the RPM the faster the machine will travel. When climbing a gradient or hill, the operator should keep the accelerator pedal depressed because the speed of the machine will reduce as the gradient increases.

The engine will not start unless the forward/reverse lever is in the neutral position while turning the key. The machine will not drive unless the interlocking seatbelt is connected.

#### “Inching/Brake” Pedal

This pedal has two functions;-

1. ‘Brake’ pedal – to stop the machine quickly.
2. ‘Inching’ pedal –to allow small controlled movements of the machine regardless of how high the engine speed is.

The inching/brake pedal allows the operator to control the travel speed of the Moffett Truck-Mounted Forklift while keeping engine speed up to raise and tilt the fork carriage. The operator should keep the forklift RPM high if he wants to raise the boom quickly.

To stop the forward movement of the Moffett Truck-Mounted Forklift while maintaining high engine RPM, depress the inch pedal fully and the machine will stop moving. By releasing the “inching/brake” pedal slightly, the machine will move slowly. To stop its movement depress the pedal fully again. By gradually releasing the “inching/brake” pedal, the machine will gradually increase its travel speed.

Because of its ability to stop the machine, the “inching/brake” pedal can be used as a brake pedal. By fully depressing the “inching/brake” pedal the machine will stop, irrespective of the engine speed.

This pedal is also referred to as a “creeper/brake” pedal for its ability to move the machine slowly even with high engine RPM. This permits the precise, controlled creeping movements necessary when lifting or placing a load.

## 2. INTRODUCTION

### Mast Controls (3 Wheel Drive)

The Moffett Truck-Mounted Forklift is equipped with hydraulic levers to control movement of the mast, forks and stabilisers. **STUDY THE VALVE BANK DECAL FOR YOUR MOFFETT TRUCK-MOUNTED FORKLIFT BEFORE OPERATING THE MACHINE.**

#### A. Forks – Raise and Lower:

This lever raises and lowers the forks. Forward movement of the lever will lower the forks down. Backward movement of the lever will raise the forks up.

#### B. Reach Device – Extend and Retract:

This lever moves the reach device forwards and backwards. Forward movement of the lever extends the reach device forward, away from the operator (out). Backward movement of the lever retracts the reach device back towards the operator (in). When placing a load, the reach device should be extended only when the stabilisers are fully lowered.

**C. Tilt Mast – Forward and Back:** This lever tilts the mast forwards and backwards. Forward movement of the lever tilts the mast forward (Forks Down). Backward movement of the lever tilts the mast rearward (Forks Up). Loads should normally be transported with the mast tilted back.

#### D. Side-Shift – Left and Right:

This lever moves the mast to the right or left. Forward movement of the lever shifts the mast to the left. Backward movement of the lever shifts the mast to the right.

#### E. Stabilisers – Lower and Raise:

This lever raises and lowers the stabilising legs. When placing a load, the stabilisers must always be fully lowered before moving the reach device forward. Forward movement of the lever will lower the stabilisers (down). Backwards movement of the lever raises the stabilisers (up). When lifting a load, never raise the stabilisers until the mast is fully retracted.

**Note:** When the ground is not firm enough to support the stabilisers extra support plates must be used of sufficient size and strength to ensure they do not sink, bend or buckle during operation. A second person may be required to check the support plates. If at any time the stabilisers or pads show sign of sinking the procedure must be stopped immediately, the reach device fully retracted and an alternative location found. If in doubt prior to or during an operation on loose, uneven or soft surfaces, stop. Always consider safety first.

### 3. INTRODUCTION

#### Mast Controls (continued)

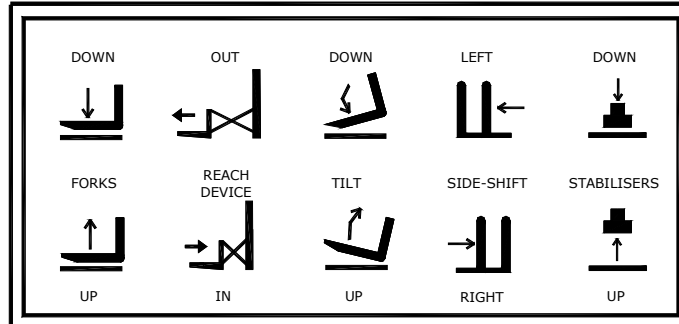

A

B

C

D

E

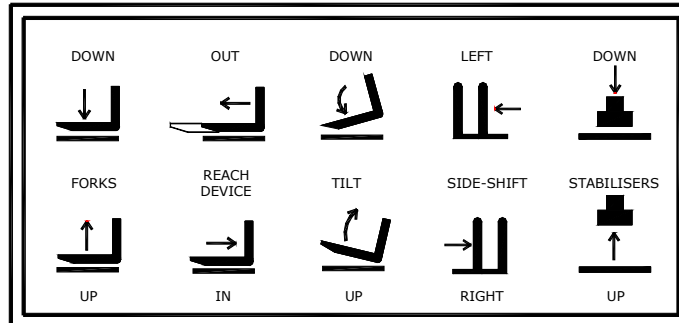

### 3. INTRODUCTION

#### **Mast Controls (1 Wheel Drive with Telescopic Legs)**

The Moffett Truck-Mounted Forklift is equipped with hydraulic levers to control movement of the mast, forks and stabilisers. **STUDY THE VALVE BANK DECAL FOR YOUR MOFFETT TRUCK-MOUNTED FORKLIFT BEFORE OPERATING THE MACHINE.**

##### **A. Forks – Raise and Lower:**

This lever raises and lowers the forks. Forward movement of the lever will lower the forks down. Backward movement of the lever will raise the forks up.

##### **B. Reach Device – Extend and Retract:**

This lever moves the reach device forwards and backwards. Forward movement of the lever extends the reach device forward, away from the operator (out). Backward movement of the lever retracts the reach device back towards the operator (in). When placing a load, the reach device should be extended only when the stabilisers are fully lowered.

**C. Tilt Mast – Forward and Back:** This lever tilts the mast forwards and backwards. Forward movement of the lever tilts the mast forward (Forks Down). Backward movement of the lever tilts the mast rearward (Forks Up). Loads should normally be transported with the mast tilted back.

##### **D. Side-Shift – Left and Right:**

This lever moves the mast to the right or left. Forward movement of the lever shifts the mast to the left. Backward movement of the lever shifts the mast to the right.

##### **E. Telescopic Legs – Extend and Retract:**

This lever extends or retracts the telescopic legs. Forward movement of the lever extends the legs outwards (out). Backward movement of the lever retracts the telescopic legs back towards the operator (in).



#### **WARNING:**

The telescopic legs should only be retracted when necessary for truck mounting the machine for transport, and should be extended fully before attempting to operate the machine.

### 3. INTRODUCTION

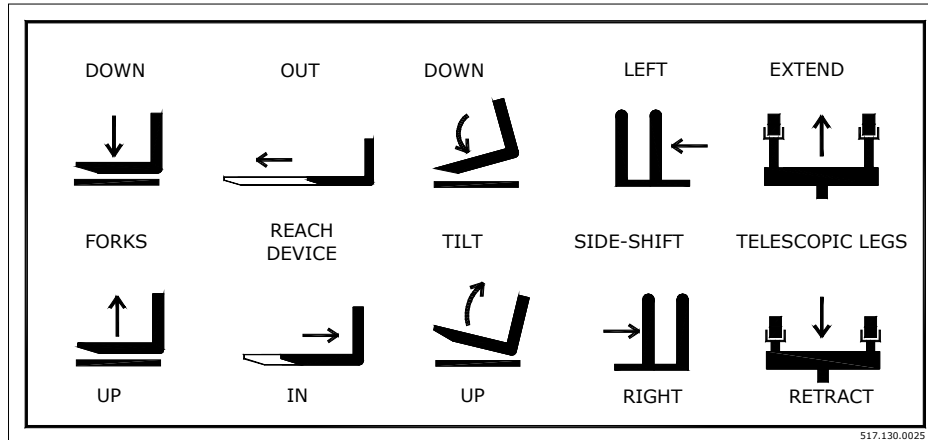

A

B

C

D

E

### 3. CENTRE OF GRAVITY

#### Basic Principles

##### Introduction

Make the right start – know the load capacities of your Moffett Truck-Mounted Forklift. The rated capacity of the machine is the weight that the machine is capable of lifting under safe operating conditions. Remember that type of terrain or ground conditions can reduce the amount you should lift.

The shape of the load will also affect the lift capacity of the machine. Inspect the load you intend to lift. Make sure that you know the weight of the load. If the weight is not marked or shown on the load, check the weight of the load with your supervisor or have it weighed. If it is too heavy split the load and restack it. It is common for a large capacity conventional forklift to be used when loading trucks or trailers in a yard. Do not expect the Moffett Truck-Mounted Forklift to lift the load just because a conventional yard forklift initially loaded it.

Remember that, if attachments are used other than the standard pallet, lumber, brick or block forks which are normally furnished with the Moffett Truck-Mounted Forklift, such attachments will reduce the lifting capacity and affect other machine handling characteristics.

With the Moffett Truck-Mounted Forklift rated capacity is based on a cube measuring 1200mm in all three dimensions with the centre of gravity in the centre of this cube. This is known as a 600mm-load centre. If the dimensions of the load increase or the position of the centre of gravity or load moves forward, the lifting capacity of the machine will be reduced.

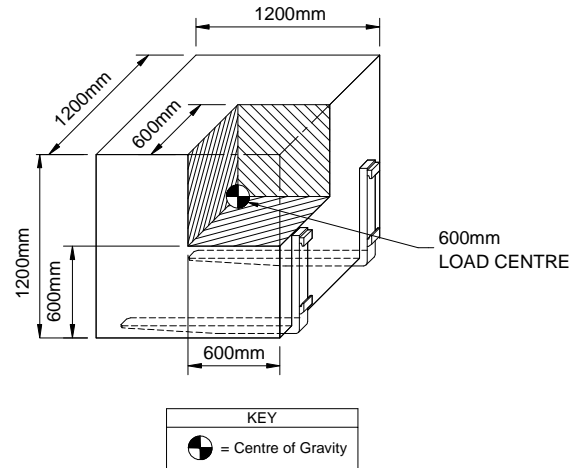

### 3. CENTRE OF GRAVITY

#### Basic Principles (continued)

##### Introduction

Refer to the load chart in the operator's compartment of your machine. Study it carefully and make sure you understand it before attempting to operate the Moffett Truck-Mounted Forklift. Remember that the weight to be lifted and the height it is lifted to must not exceed the rated capacity of your machine.

The load capacity chart relating to your particular model gives details of what your machine can lift with a 600mm load centre under the following conditions; Maximum lift height for a given load. Stabilisers raised and reach device fully extended forward. Stabilisers fully lowered and reach device fully extended forward. Stabilisers raised and reach device retracted backwards.

The following sample Load Capacity Chart illustrates the rated stacking capacity of a M4 Moffett Truck-Mounted Forklift equipped with reach device.

##### Note:

1. The load capacity may vary depending on attachments used. Consult the load chart on your machine for actual rated capacity.

2. Other Moffett Truck-Mounted Forklift models have different load capacities. Refer to the load capacity chart on your machine.
3. If the existing load capacity chart becomes damaged, lost or illegible, replace the load capacity chart. Load capacity charts are available from your dealer.

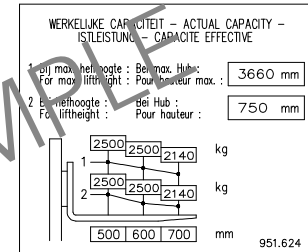
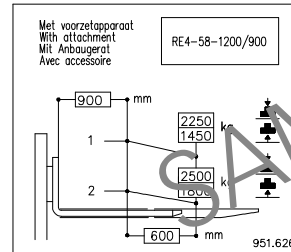

##### **DANGER:**

Never exceed the forklifts rated capacity or the machine may become unstable and could cause serious injury or death.

### 3. CENTRE OF GRAVITY

#### Basic Principles (continued)

#### Comparison Between A Conventional Forklift And A Moffett Truck-Mounted Forklift

##### Conventional Forklift

A **conventional forklift** is designed to lift and carry the load in front of the wheels. The load remains in this position during transit. The conventional forklift is able to lift the load in this position because it has a large rear-mounted counterweight to counterbalance the load. A conventional forklift is known as a counterbalanced forklift.

With a conventional counterbalanced forklift, the position of the load remains stationary relative to the front wheels. The front wheels of a conventional counterbalanced forklift are the points of pivot known as the fulcrum point.

If the load exceeds the rated capacity of the forklift, the weight of the load may overcome the counterbalance effect and cause the load and the forklift to tip forward.

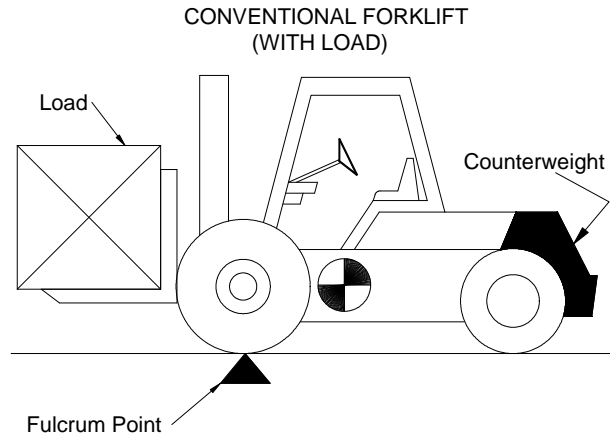



### 3. CENTRE OF GRAVITY

#### Basic Principles (continued)

#### Comparison Between A Conventional Forklift And A Moffett Truck-Mounted Forklift

##### Moffett Truck-Mounted Forklift

An important feature of the Moffett Truck-Mounted Forklift is that it is light enough to be transported on the rear of the truck or trailer. Unlike a conventional forklift, it does not have a rear-mounted counterweight. The Moffett Truck-Mounted Forklift has telescopic forks or pantograph and hydraulic stabilisers. With the stabilisers raised the fulcrum point is at the front wheel.

When the stabilisers are fully lowered, the fulcrum point moves forward to the point of contact between the stabilisers and the ground.

This action increases the counterbalance effect and enables the Moffett Truck-Mounted Forklift to lift the rated capacity with the reach device in the forward position without the need for a large counterweight.

When placing a load, the stabilisers must always be fully lowered before the reach device is extended. When lifting a load, the stabilisers must be fully lowered and raised only after the reach device is retracted fully. When carrying a load the reach device must always be retracted fully.

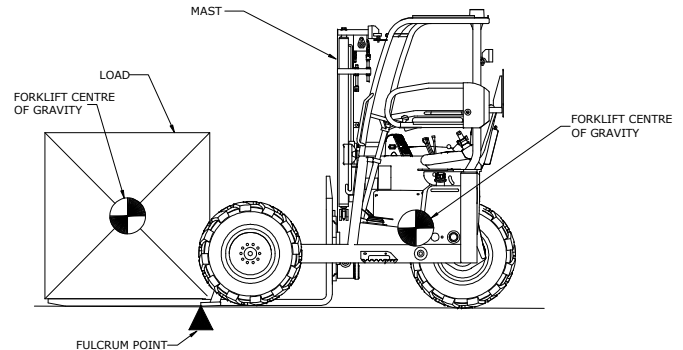
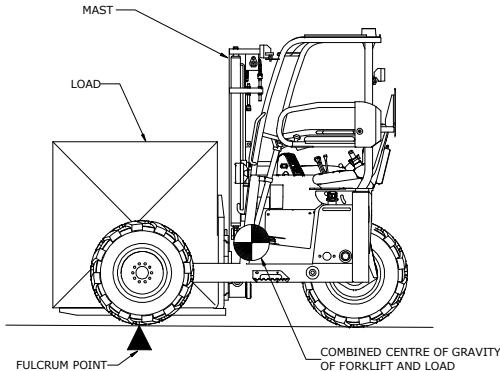

## 4. OPERATING PROCEDURES

### Using the Machine

#### Before Using The Machine

Before you begin to operate the Moffett Forklift you must have completed the Moffett training program, understand and follow all information in this manual. Each day you operate the machine, complete all of the Daily Inspection Checks as detailed in the MAINTENANCE section of this operator manual.

#### Entering Operator's Compartment

Always climb aboard the vehicle properly. Use "three point contact" method and face the machine when you climb aboard or dismount the Moffett Truck-Mounted Forklift "three point contact" means that 3 out of 4 arms and legs are in contact with the machine at all times during mount and dismount. Clean your shoes and wipe your hands before climbing on. Use the overhead guard, grab-handle and step when climbing on or off. Do not use the side guard as a grab-handle. Make sure the side guard is secured before mounting or dismounting. Never climb aboard or dismount when the engine is running or when the machine is moving. Never use the control levers or the steering wheel as a hand-hold when climbing on or off the Moffett Truck-Mounted Forklift.



#### WARNING:

Never climb aboard or dismount the machine with engine running.

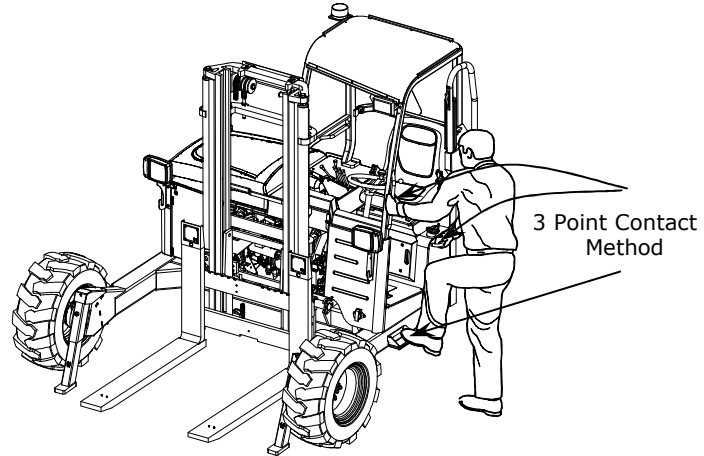

## 4. OPERATING PROCEDURES

### Overhead Guard

**The Overhead Guard (OHG) is designed to give you protection in an accident. You must always wear your seat belt and close the side guard, you could be thrown about inside the drivers compartment, or thrown out of the machine and crushed. Always fasten the seat belt and close side guard before starting the machine.**

If the machine is involved in an accident, hold onto the steering wheel tightly, brace your feet and lean away from impact. When the machine comes to a rest, switch the starter key to the OFF position, remove the seat belt and exit the machine.

Never carry out any unauthorised alterations to the overhead guard, eg. Lowering the roof height, drilling, welding on brackets for a fire extinguisher, radio aerial or other equipment, without first having discussed the alteration with engineering personnel at Moffett Engineering Ltd. Engineering Department.

Any modification can adversely affect the structural integrity of the overhead guard and could cause the overhead guard to fail in the event of an accident.

Location of Overhead Guard Conformity Plate

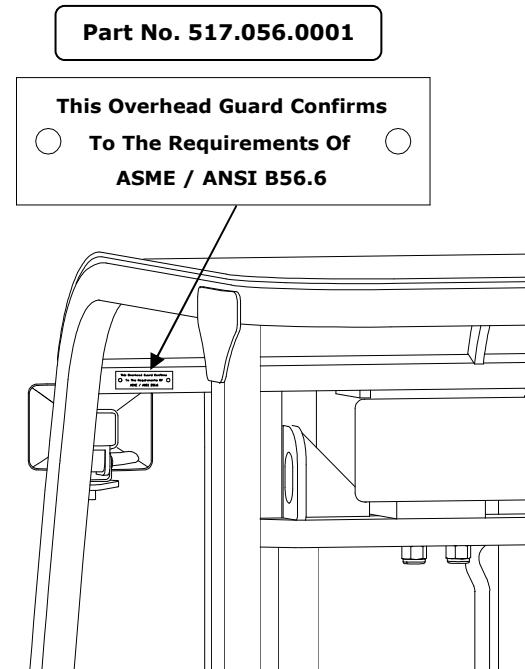

## 4. OPERATING PROCEDURES

### Rollover



**DANGER:**

Any machine that is used to lift and move loads may tip over if not operated correctly. No matter how experienced the operator is, accidents can still happen if the operator does not remain vigilant. Always be aware of the potential danger involved when using the Moffett Truck-Mounted Forklift. Be aware of what action you **MUST** take if the machine starts to tip or roll over.

**DO NOT ATTEMPT TO JUMP OUT – STAY IN THE MACHINE  
HOLD TIGHTLY ONTO THE STEERING WHEEL – BRACE YOUR FEET  
AND LEAN AWAY FROM IMPACT**

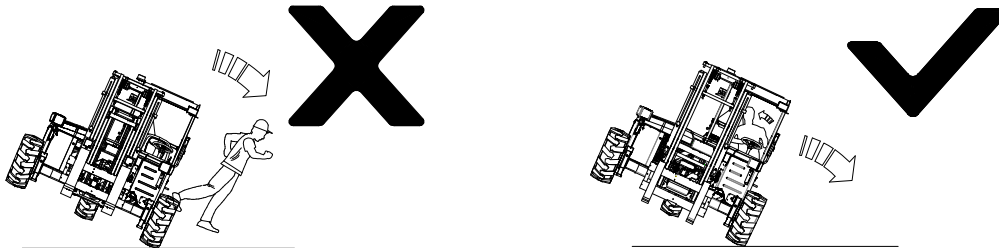

**WHEN THE MACHINE HAS COME TO REST – EXIT VIA SAFEST ROUTE**

## 4. OPERATING PROCEDURES

### Using the Machine

#### Adjusting the Seat

The operator's seat can be adjusted for your comfort. A correctly adjusted seat will reduce operator fatigue. Position the seat so that you can comfortably reach the machine controls. Make sure that you can depress the foot controls fully with you back against the seat back.

#### Fasten the Seat Belt and Close the Side Guard.



#### WARNING:

Always wear your seatbelt when driving the Moffett Truck Mounted Forklift. The Forklift may tip over if operated incorrectly. To protect the operator from risk of serious injury or death in the event of a tip over, it is best to be held securely in the seat. The seat and seatbelt will help to keep you safely within the operator's compartment. In the event of a tip over **DO NOT JUMP** grip the steering wheel, brace your feet and lean away from direction of tip over staying within the operator's compartment.



#### WARNING:

When checking the seat belt, if it does not lock, do not drive the machine. The seat belt assembly must be replaced immediately.

1. Sit correctly in the seat. Make sure the belt is not twisted. Push the male end **C** into the buckle **A** until it latches.
2. Make sure the seat belt is across your hips and not over your stomach.
3. Press button **B** to release the seat belt.

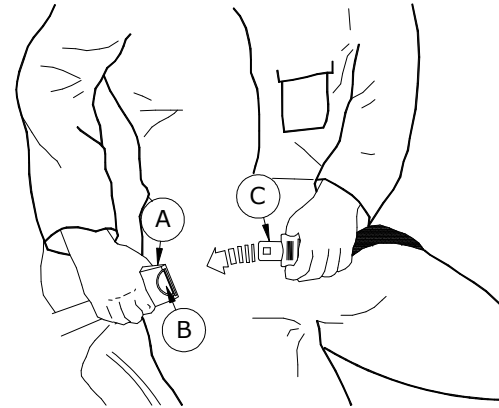

**Note:** The Forklift will not drive unless the seat belt is connected across the operator's hips.

## 4. OPERATING PROCEDURES

### Starting The Engine

#### Start Safely

Adjust the seat, fasten the seat belt and close the side guard. Ensure all operating controls including the forward/reverse pedal, and hydraulic levers are in the neutral position before starting. Alert people in the area before starting the machine. When starting your equipment in an enclosed space, make sure that there is adequate ventilation.



#### **WARNING:**

Do not use starting fluid or spray as these are highly flammable, corrosive and cause engine damage.

Insert the key in the ignition. Depress the accelerator pedal half way and turn the key until the starter engages and the engine starts. Do not engage the starter for any more than 10 seconds. Release the key and it automatically returns to the "on" position. If the engine fails to start turn off the key for 30 seconds and repeat the starting procedure.

**Note:** If the engine is cranked excessively a "thermal switch" may cut in to prevent the starter motor from over heating. If this occurs wait 30 seconds push the reset button and retry starting the machine.

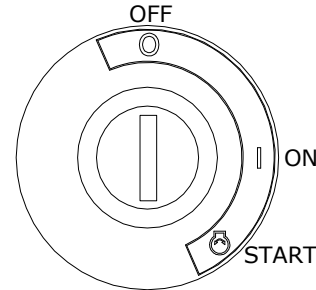

After starting, check that all red instrument panel warnings lights have gone out and that all gauges are functioning properly. If all red warning lights have not gone out, stop the engine immediately. Do not attempt to operate the Moffett Truck-Mounted Forklift with a warning light on, as serious damage could occur to the engine.

## 4. OPERATING PROCEDURES

### Driving Techniques

**Note:** Before driving machine read manual thoroughly and carry out a pre- trip inspection.

#### Driving Forward

When driving a loaded machine forward, always accelerate smoothly and slowly. If you accelerate quickly or with jerky movements, the load could fall or the machine may become unstable. Keep the forks retracted and the load as low as possible. Always drive the machine slowly to avoid the risk of having to brake sharply. Always make sure your route is clear of obstructions and take care to avoid endangering pedestrians.

#### Reversing

When reversing, turn your head to face the direction of travel or get assistance of a reliable person to guide you. Always make sure your route is clear of obstructions and take care to avoid endangering pedestrians. Always ensure the reverse beeper is functioning correctly and can be heard clearly by people around the machine.

#### Turning

The machine may become unstable if you turn too quickly or too sharply. Always turn slowly and smoothly. If you turn too quickly or too sharply, the load could fall off or the machine could become unstable. Keep the load as low as possible.

The Moffett Truck-Mounted Forklift steers from the rear and can turn on a very tight radius. Tail swing and fork swing must be considered when turning. Always turn slowly and check for clearances at the fork tips and both rear corners of the forklift. When the machine turns, it rotates around either the right front or the left front wheel depending on the direction of the turn. Therefore, the operator must be aware of the unequal turning arcs relative to the offset seating position.

#### Parking

Always park the Moffett-Truck Mounted Forklift in a designated safe area. Apply the park brake. Lower the forks fully to the ground. Neutralise all controls. Switch off the ignition and remove the key. Chock the wheels if the vehicle is on uneven ground.

**If parking on an incline,** point the machine uphill, chock the front wheels and turn the rear wheel across the incline.

**Note:** For machines equipped with a brake on the rear hub, it is recommended that the stabilisers are lowered when parking the machine on incline.

## 4. OPERATING PROCEDURES

### Driving Techniques (continued)

#### Operating On Inclines

The Moffett Truck-Mounted Forklift is intended for use on firm, flat and stable surfaces. AVOID slopes and uneven or unstable surfaces where possible. However, when job site conditions involve slopes, inclines or rough terrain, you must take additional care when operating the machine.

- Do not travel across an incline.
- ALWAYS APPROACH AN INCLINE STRAIGHT ON AND TRAVEL UP AND DOWN THE INCLINE.
- Keep the forks pointed uphill.
- Always travel in reverse when descending an incline.
- Do not turn on an incline.
- Never stop or start suddenly.
- Operate all controls smoothly.
- Watch out for potholes or other obstacles that could affect the stability of the machine.
- Drive slowly over rough terrain.
- Where necessary, engage the diff-lock and travel slowly for additional traction.
- Do not attempt to reverse down an incline that you think you would have difficulty driving up.

#### Operating with a load:

- Travel with the load and forks facing uphill.
- Never travel across a slope.
- Make allowances for a reduction in both stability and lift capacity when operating on inclines.
- Always take great care when transporting wide loads on any incline. Carry the load as low as possible above the frame of the machine.
- Keep the reach device fully retracted.

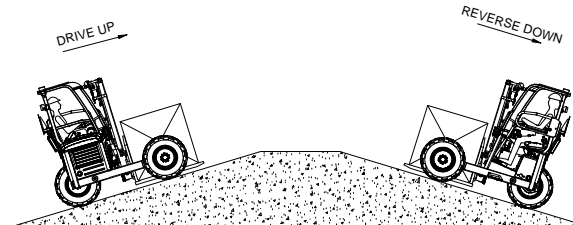



## 4. OPERATING PROCEDURES

### Driving Techniques (continued)

#### Operating without a load

- Keep the forks as low as possible.
- Remember that your safety is most important and should not be compromised. You are the operator and you are in control of your safety. Do not take any chances!

Always wear your seat belt when driving the Moffett Truck-Mounted Forklift. The machine may tip over if operated incorrectly. In the event of a tip over, it is best to be held securely in the seat, to protect you from the risk of serious injury or death.

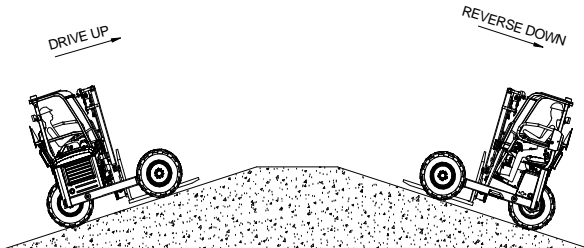

#### **WARNING:**

Always wear your seatbelt when driving the Moffett Truck-Mounted Forklift. The forklift may tip over if operated incorrectly. To protect the operators from the risk of serious injury or death in the event of a tip over, it is best to be held securely in the seat. The seat and seatbelt will help keep you safely within the operator's compartment. In the event of a tip over, DO NOT JUMP. Grip the steering wheel, brace your feet, lean away from the direction of tip-over and stay within the operator's compartment.

## 4. OPERATING PROCEDURES

### Diff-Lock

#### Operation of Diff-Lock

Under normal driving conditions the Moffett Truck-Mounted Forklift operates in all-wheel drive. However, in the event of one or more wheels losing grip, the machine may lose traction, stop or skid. By engaging the diff-lock, you will get equal positive drive to all three wheels.

#### When to use Diff-lock

- If one or more wheels lose traction while travelling through soft or slippery ground conditions.
- To maintain traction while travelling on slopes or inclines.
- To improve braking and traction when reversing downhill.

#### To avoid damage to the hydraulic system:

- Do not engage the diff-lock when the machine is moving.
- Do not use the diff-lock where traction is good.
- Do not use the diff-lock when turning corners.



#### **CAUTION:**

Use the diff-lock only while travelling in a straight line.

#### How to activate the Diff-lock

##### 1. For Foot-Pedal Control

- a) Return the forward/reverse pedal to neutral position to stop the machine.
- b) Check to see that the rear wheel is in the straight-ahead position.
- c) Engage the diff-lock switch.
- d) Increase the engine revs to full RPM.
- e) Depress the forward/reverse pedal lightly in the required direction.
- f) Do not overload the engine.
- g) The diff-lock may be released while the machine is in motion.

##### 2. For Automotive Type Control

- a) Release the accelerator pedal to stop the machine.
- b) Check to see that the rear wheel is in the straight-ahead position.
- c) Engage the diff-lock switch.
- d) Select forward or reverse.
- e) Increase the engine RPM to move the machine.
- f) Drive the machine slowly while the diff-lock is engaged.
- g) The diff-lock may be released while the machine is in motion.

## 4. OPERATING PROCEDURES

### Stopping Procedure

When stopping the machine follow the sequence below:

- Neutralise all hand control levers, the accelerator and the forward/reverse pedal.
- Lower the forks to the ground.
- Engage the park brake.
- Switch off the ignition and remove the key.
- Release the seatbelt.
- Dismount using the 3-point contact method.



#### **WARNING:**

If the Forward/Reverse pedal does not return to the neutral position, do NOT use the machine and contact your supervisor.



#### **WARNING:**

Never leave the operator's seat without first

- Facing the machine uphill and turning the rear wheel sideways if stopped on an incline.
- Lowering the forks to the ground.
- Placing all controls in the neutral position.
- Engaging the park brake.
- Turning of the engine.

### Loose Articles

Remove or secure all loose articles in the operator's compartment - such as lunch boxes, tools etc.



#### **WARNING:**

Loose articles can fall and strike you, or roll on the floor. You could be knocked unconscious, or the controls could get jammed. If that happens you could lose control of the machine.



#### **CAUTION:**

If something comes loose, breaks or fails to operate:

- Stop.
- Shut down the engine.
- Get it repaired.

## 4. OPERATING PROCEDURES

### Basic Load Techniques

#### Travelling without a load:

- Keep the reach device retracted and as low as possible.

#### Travelling with a load:

- Keep the reach device fully retracted when travelling.
- Lower the stabilisers fully before extending the reach device to place a load.
- When lifting a load keep the stabilisers fully lowered until the reach device is fully retracted.
- Keep the load as low as possible.



#### **WARNING:**

**Stabilisers.** When placing a load, always place the load on firm and level surface. The stabilisers must always be fully lowered before attempting to extend the reach device. When lifting a load, the stabilisers must be fully lowered and raised only when the reach device is fully retracted.



#### **DANGER:**

**Stabilisers.** Never raise the stabilisers when the reach device is extended with a load on.

**Note:** When the ground is not firm enough to support the stabilisers extra support plates must be used of sufficient size and strength to ensure they do not sink, bend or buckle during operation. A second person may be required to check the support plates. If at any time the stabilisers or pads show sign of sinking the procedure must be stopped immediately, the reach device fully retracted and an alternative location found. If in doubt prior to or during an operation on loose, uneven or soft surfaces, stop. Always consider safety first.

## 4. OPERATING PROCEDURES

### Lifting And Placing Loads

#### A. CUBED LOADS

A cubed load is one that fits between the front wheels and the frame of the machine. To achieve maximum machine and load stability, the load should be carried with the reach device fully back and as low as possible between the frame of the machine at all times. A common type of cubed load would be bricks, blocks, bagged goods or turf grass.

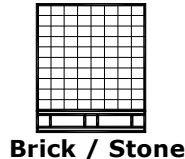
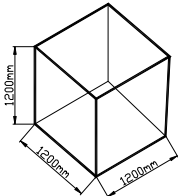

**Brick / Stone**



**Turf Grass**

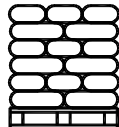

**Bagged Goods**

#### Lifting a cubed load from ground level

**Note:** Make sure the load to be lifted is stable and secure. Check the weight and load centre of the load to be lifted. If the weight is not marked or shown on the load, check the weight of the load with your supervisor or have it weighed. If it is too heavy, split the load and restack it.

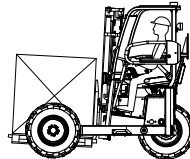
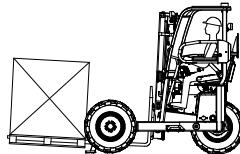
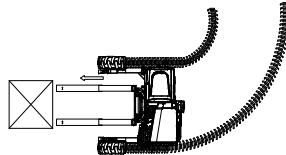

1. Align the forks to suit the load.
2. Approach the load squarely and drive slowly forward until the forks are fully engaged.
3. Check that the surface is strong enough to support the stabilisers. If not, place a metal or wooden support underneath which is strong enough to support the stabilisers.
4. Lower the stabilisers fully.
5. Tilt the mast rearwards slightly to secure the load.
6. Raise the forks to lift the load.
7. Side-shift the mast to the centre position.
8. Retract the reach device fully.
9. Raise the stabilisers fully.
10. Slowly drive away looking in the direction of travel.

## 4. OPERATING PROCEDURES

### Travelling with a cubed load

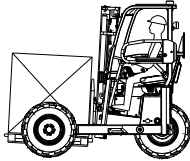

1. Carry the load as low as possible between the frame of the machine.
2. Keep the reach device retracted fully.
3. Tilt the mast back.
4. Do not side-shift the load while travelling or turning.
5. Use caution when starting or stopping. Drive slowly and avoid sudden movements.
6. Always look in the direction of travel.

### Placing a cubed load at ground level

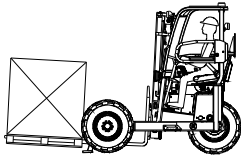

1. Check the area and be certain that the load can be safely placed.
2. Approach the placement area squarely.
3. Check that the surface is strong enough to support the stabilisers. If not, place a metal or wooden support underneath which is strong enough to support the stabilisers.
4. Lower the stabilisers fully.
5. Extend the reach device fully.
6. Lower the forks to the ground.

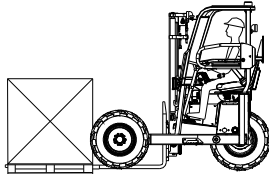

7. Tilt the mast forward slightly to deposit the load.
8. Raise the stabilisers fully.
9. Back up carefully until the forks are clear of the load.
10. Retract the forks fully.
11. Drive away slowly looking in the direction of travel.

## 4. OPERATING PROCEDURES

### B. WIDE LOADS

A wide load is a load that will not fit between front wheels and frame of the forklift. A common type of wide load is piping or timber products.

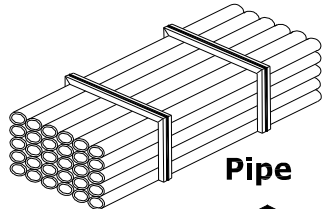

Pipe

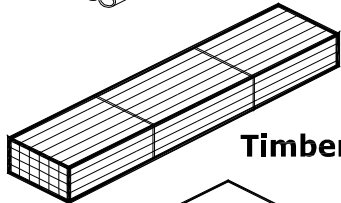

Timber

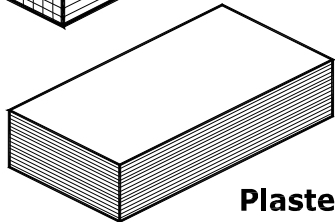

Plaster Board

### Lifting a wide load

**Note:** Make sure the load to be lifted is stable and secure. Check the weight and load centre of the load to be lifted. If the weight is not marked or shown on the load, check the weight of the load with your supervisor or have it weighed. If it is too heavy, split the load and restack it.

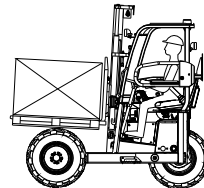
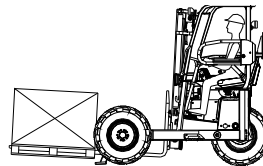
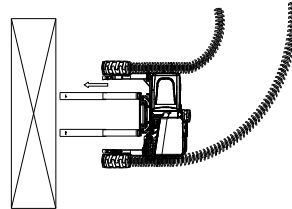

1. Approach the load to be lifted.
2. Extend the reach device fully.
3. Space the forks to suit the load.
4. Align the forks to suit the load, approach it squarely until the forks are fully engaged.
5. Check that the surface is strong enough to support the stabilisers. If not, place a metal or wooden support underneath which is strong enough to support the stabilisers.
6. Lower the stabilisers fully.
7. Raise the load to clear the ground.
8. Tilt the mast rearwards to secure the load.
9. Raise the load to clear the frame and wheels of the forklift.
10. Side-shift the mast to the centre position.
11. Retract the reach device fully to bring the load above the front wheels.
12. Raise the stabilisers fully.

## 4. OPERATING PROCEDURES

### Travelling with a wide load

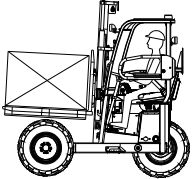

1. Carry the load as low as possible above the frame of the machine.
2. Keep the reach device retracted fully.
3. Tilt the mast back.
4. Do not side-shift the load while travelling or turning.
5. Drive slowly and avoid sudden movements.
6. Always look in the direction of travel.

### Placing a wide load

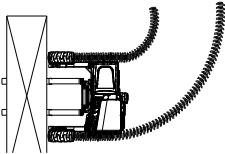

1. Check that the area is clear of debris.
2. Approach the final position squarely.
3. Stop and side-shift the load if necessary to align it with the final resting position.
4. Check that the surface is strong enough to support the stabilisers. If not, place a metal or wooden support underneath, strong enough to support them.

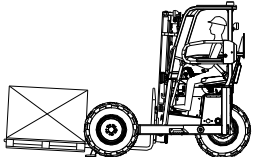

5. Lower the stabilisers fully.
6. Extend the reach device fully to clear the frame and wheels of the machine.
7. Lower the forks to the ground.

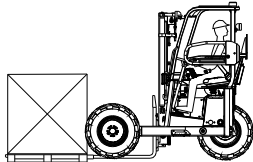

8. Tilt the mast forward slightly to deposit the load.
9. Raise the stabilisers fully.
10. Back up carefully.
11. Drive slowly facing the direction of travel, keeping the reach device retracted fully.



### **CAUTION:**

When carrying wide loads your visibility may be blocked by the load. It may be safer to travel in reverse when moving with such loads. You may require a signal person or "spotter" to guide you. Do not drive uphill in reverse. If the street lights are blocked by the load the work lights must be used to improve visibility and ensure you are seen by other road users.



## 4. OPERATING PROCEDURES

### C. NON PALLETISED OR LOOSE LOADS

- Use skids when necessary to allow insertion of the forks beneath the load.
- Do not allow the skids to interfere with the fork placement.
- Secure loose loads to prevent them from falling or shifting
- Consult your supervisor before attempting to secure a loose load.
- Never attempt to handle a load which has been poorly wrapped or banded as it could injure you or others working around you.
- Follow the same procedure for handling cubed or wide loads when lifting or placing non-palletized or loose loads.

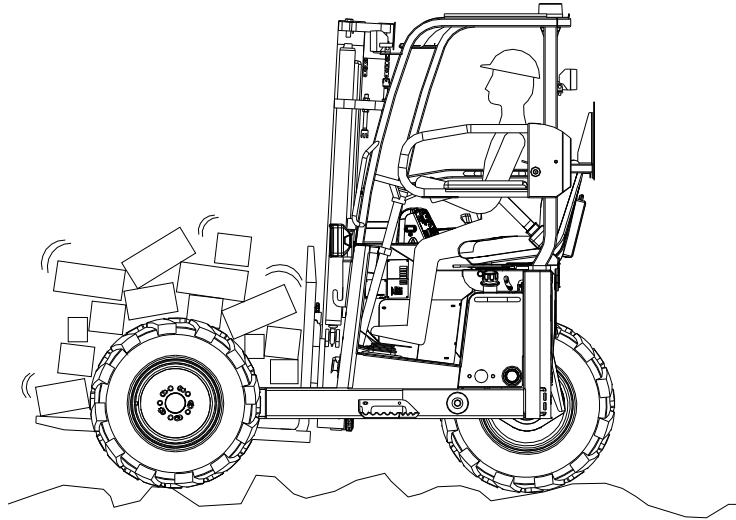

## 4. OPERATING PROCEDURES

### Loads Above Ground Level

#### These techniques apply to:

- Stacking one load on top of another.
- Loading a truck or trailer.
- Unloading a truck or trailer.
- **Picking up a load above ground level (E.g. unloading a trailer)**
- Check the weight and load centre of the load to be lifted. If the weight is not marked or shown on the load, check the weight of the load with your supervisor or have it weighed.
- Adjust the fork height to suit the load.
- Centre the forks and approach the load squarely.
- Extend the reach device until the forks are fully engaged.
- Do not touch the pick-up area with the mast.
- Side-shift the mast to centre the load on the forks.

- Check that the surface is strong enough to support the stabilisers. If not, place a metal or wooden support underneath, strong enough to support them.
- **Lower the stabilisers fully.**
- If it is not possible to engage the forks fully, follow the procedure outlined in the section titled "Double Forking" until the forks are fully engaged. Raise the forks to lift the load clear of the pick-up area.
- Tilt the mast rearwards to make the load more stable.
- If necessary, raise the load to clear the frame of the machine.
- Retract the reach device fully.
- **Raise the stabilisers fully.**
- Check behind and back up slightly to clear the pick-up area or vehicle body.
- Never manoeuvre or turn with a raised load.

- Lower the load as close to the ground as possible.
- Back out and drive away slowly, looking in the direction of travel.

### Double Forking

If it is not possible to engage the forks fully when lifting the load from a truck or trailer, it will be necessary to move the load to the edge of the body of the vehicle before picking it up. This is known as "Double Forking". Remember that the lift capacity of the machine is reduced if the forks are not fully engaged.

### To "Double Fork" the load

Raise the load slightly and retract the reach device sufficiently to bring the load out to the edge of the vehicle body. Lower the load back on to the vehicle body and fully engage the forks by moving the reach device forward again. The load is now ready to be lifted.

## 4. OPERATING PROCEDURES



### **WARNING:**

Before attempting to load a truck or trailer, chock the wheels of the truck/trailer to prevent it moving. Always lower the stabilisers fully before attempting to pick-up from a truck or trailer.

### **Placing or stacking a load above ground level**

- Approach the landing area squarely and with care.
- Side-shift the load if necessary.
- Raise the load above the level of the landing area or trailer.
- Drive forward carefully and make certain that the front of the machine does not hit the landing area or trailer.
- Check that the surface is strong enough to support the stabilisers.

### **Lower the stabilisers fully.**

- Extend the reach device fully until the load is directly above the landing area or trailer.
- Lower the load carefully.
- Tilt the mast forward to position the load and place it on the resting area.
- Raise the stabilisers slowly.
- Back up cautiously to clear the load and landing area.
- Lower the forks as low as possible to the ground.
- Back up slowly, looking in the direction of travel.



### **WARNING:**

When lowering the stabilisers, make certain the ground is sufficiently firm to support the stabilisers. On loose or uneven soil, it may be necessary to place a flat wooden or metal support beneath the stabilisers.

### **Additional precautions when placing a load above ground level:**

- Where visibility is restricted, use a signal person.
- Make certain that the landing area is of sufficient strength to carry the load.
- Also, check that the landing area is level and clear of debris.
- Never side-shift with a raised load. The stability of the Moffett truck-mounted forklift will be compromised and the machine may tip over.
- Always move controls in a smooth, steady manner. Do not force a hydraulic cylinder to the end of its stroke as the resulting "jolt" could spill the load.
- **Under no circumstances should a load be placed on or lifted from a scaffold platform.**

## 5. MOUNTING PROCEDURES

### Introduction

The Moffett Truck-Mounted Forklift is designed to be transported on the rear of a truck or trailer.



### WARNING:

A Moffett approved mounting kit must be fitted to your vehicle for transporting the Truck Mounted Forklift. Contact your truck mounted forklift distributor for further details of approved mounting kits.

During transport the the weight of the of the Moffett Truck-Mounted Forklift rest on the "sliding boxes" of the mounting kit. The machine is pressurised down onto the mounting kit and the safety chains do not carry the weight of the machine. The stop lights and directional signal lights of the truck or trailer are connected to the Moffett Truck-Mounted Forklift by means of an electrical cable (wiring pigtail).



### WARNING:

Do not attempt to transport the Moffett Truck-Mounted Forklift unless you have read this section of the manual very carefully!

**Note:** When the Moffett is not on the kit the rear bumper **MUST** be folded out and pinned at all times, ensuring lights are visible at all times.

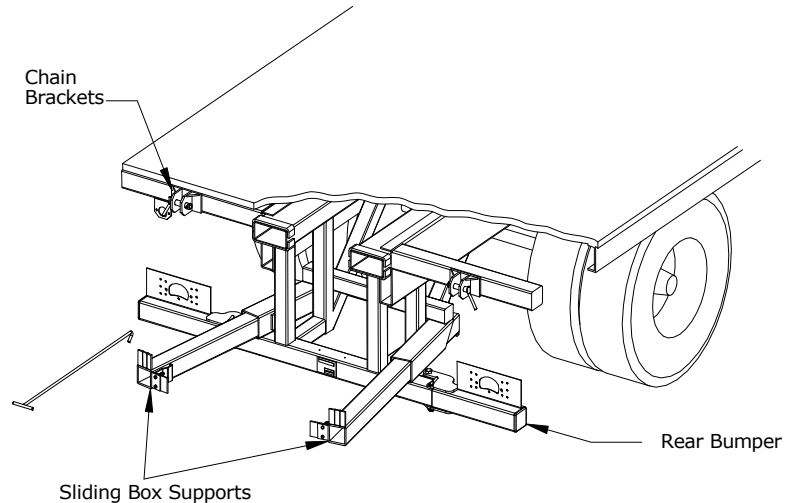

## 5. MOUNTING PROCEDURES

### Mounting Procedure

- On trailers, the folding rear bumper should be folded in and pinned on both sides.
- Adjust the forks equally on the fork carriage to align them with the fork guides and ensure they are positively locked in place on the forkrail.
- Carefully retract the telescopic legs. (If fitted)
- Raise the forks to align them for entry between the fork guides.
- Drive slowly forward until the forks are fully engaged between the front and rear fork supports in the mounting kit.
- On machines with folding legs extend the forks enough to allow the wheels to clear the

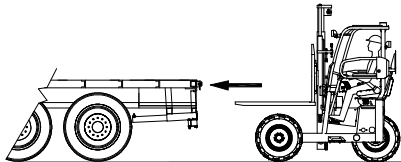

- back of the truck / trailer. Raise the wheels to clear the ground and fold the legs in and pin in place to secure. (if fitted)
- Raise the machine to clear the ground.

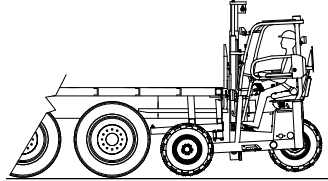

- Tilt the mast fully rearward to raise the rear wheel.
- Lower the forks using the lift lever until the bottom of the main crossmember of the machine is slightly higher than the sliding supports.

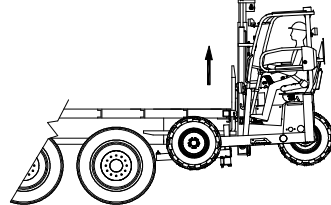

- Turn off the engine.

- Dismount using the three point contact method.
- Slide out the box sections of the mounting kit.
- Climb aboard using the three point contact method.
- Fasten seat belt.
- Start the engine.
- Power the forklift down onto the mounting kit.
- Turn the engine off.
- Dismount using the three point contact method.

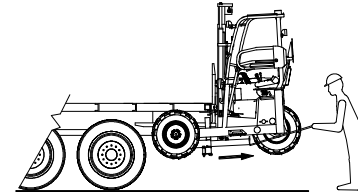

- Attach both transport chains securely to the rear of the truck or trailer and put the lock pins in place.
- Connect the suzie cable and check that all lights are functioning properly.
- Tilt up drivers seat .
- Fold up rear OHG bar and lock into position.

## 5. MOUNTING PROCEDURES

### Mounting Procedure (continued)



#### **CAUTION:**

It is important to ensure the pigtail (suzie socket) connector is fitted correctly and that the lights on the rear of the Moffett Truck Mounted Forklift are functioning properly.



#### **CAUTION:**

It is essential to keep the machine pressurized down onto the mounting kit. The safety chains do not carry the weight of the machine.

**Note:** Always ensure the park brake is off when mounting or dismounting the machine. Always wear your seatbelt, failure to do so will cause the park brake to automatically engage and make mounting difficult.

**Note:** Always remember:

- To lower the forklift you must raise the mast.
- To raise the forklift you must lower the mast.
- To tilt the forklift up you must tilt the mast back.
- To tilt the forklift down you must tilt the mast forward.



#### **CAUTION:**

The rear bumper must be folded back out to full length and the locking pin and linch pin fitted when the forklift is not being transported or removed for the purposes of loading or unloading.

## 5. MOUNTING PROCEDURES

### Dismount Procedure

- Disconnect the electrical cable and store in a safe place.
- Climb aboard using the three point contact method.
- Close the side guard fully.

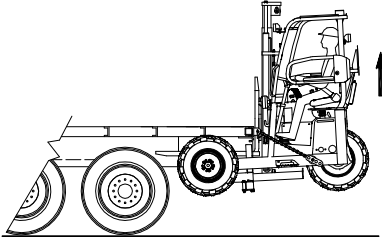

- Fasten your seatbelt.
- Start the forklift.
- Raise the forklift off the box kit by lowering the forks until the wheels slightly clear the box kit.
- Tilt the mast fully rearward. The weight of the forklift is now on the forks.
- Turn off the engine.
- Unfasten seatbelt and open the side guard fully.

- Dismount using the three point contact method.
- Slide the box sections in fully.
- Remove both slackened transport chains from the rear of the truck or trailer and place them in the hooks provided.
- Replace the pins and locks in the chain brackets.
- Climb aboard the forklift using the 3-point contact method.
- Close the side guard fully.
- Fasten the seatbelt.
- Start the engine.

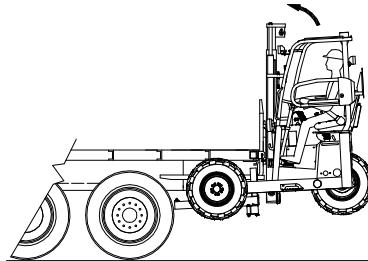

- On machines with folding legs extend the fork to allow the wheels to clear the truck /

- trailer, fold the legs out and pin to secure. (if fitted)
- Raise the forks to lower the forklift to the ground.
- Tilt the mast forward until the wheel touches the ground.
- Raise the mast slightly to pressurise the mast lift cylinder and to clear the fork brace. (This may take several seconds.)
- Ensure the rear wheel is

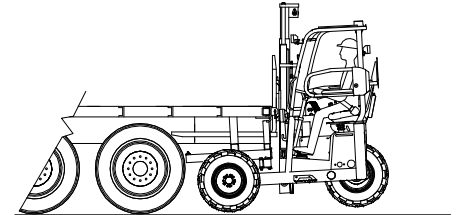

- pointing straight ahead.
- Back up slowly until the forks are fully clear of the front and rear guides.
- Extend the telescopic legs (if fitted)

## 5. MOUNTING PROCEDURES

### Dismount Procedure (continued)

- Lower the forks as low as possible and drive off, looking in the direction of travel.
- On trailers, the folding rear bumper should be extended and pinned on both sides.
- Before load handling it may be necessary to adjust the forks to suit the load or pallet.

**Note:** Always ensure that all Local and National laws are obeyed at all times. Make sure all operating and directional signal lights are functioning and visible. The rear bumper must be locked at full length when the forklift is not being transported.

**Note:** Always ensure the park brake is off when mounting or dismounting the machine. Always wear your seatbelt, failure to do so will cause the park brake to automatically engage.



#### **DANGER:**

If your machine is equipped with telescopic legs, make sure the legs are extended before attempting to operate the machine. The legs should only be retracted when mounting the machine for transport.



#### **DANGER:**

If your machine is equipped with telescopic legs, make sure the legs are extended before attempting to operate the machine. The legs should only be retracted when mounting the machine for transport.



## 5. MOUNTING PROCEDURES

### Rules For Safe Transportation

If the forklift is to be driven on public roads, be certain that all laws and regulations are obeyed. Make sure all operating and directional signal lights are functioning and visible.

When travelling on public roads or streets, obey all local traffic movement regulations.

Approach intersections with caution, observe speed and traffic control signs. Do not speed. Avoid panic stops and sharp turns. When transporting the forklift on a truck or trailer know the overall height to avoid coming in contact with overhead obstructions such as bridges, power lines etc.



### **DANGER:**

Do not attempt to transport the Moffett Truck-Mounted Forklift on a truck or trailer that is not equipped with a mounting kit designed and installed to Moffett Truck-Mounted Forklift specifications.

When carrying a Moffett Truck-Mounted Forklift, make certain that your vehicle complies with the relevant national and local laws and regulations regarding maximum vehicle weight, axle loading, overall vehicle length and overhang.

**Note:** Before mounting your machine on a truck or trailer ensure all relevant calculations have been carried out by an approved Moffett Truck-Mounted Forklift Distributor.

Ensure an approved Moffett mounting kit is fitted to the truck or trailer and that it is suitable to mount the particular Moffett Truck-Mounted Forklift.

All Moffett mounting kits must only be fitted by approved personnel.

## 6. MAINTENANCE

### General

In order to carry out a service/inspection of your Moffett truck-mounted forklift it is important that the vehicle is first thoroughly cleaned, while doing so, please note the following points.

- Ensure that engine is shut down prior to washing
- Do not wash directly onto the roller bearings (mast rollers and side-shift rollers).
- Do not wash directly onto the mast chains, the mast chains must be cleaned using a kerosene-based cleaning agent and a brush. It is very important to remove all traces of the cleaning agent using an airline to blow dry the chains.
- Lubricate chains immediately after cleaning
- Take care when washing close to electrical connections.

**Note:** In some cases your Moffett Truck-Mounted Forklift may not have enough running hours required for carrying out a routine service as indicated in the intervals on page 67, (i.e. the Moffett Truck-Mounted Forklift may only have 70 running hours or 90 days in a 12 month period). Moffett Engineering Ltd. recommends in these cases that the Moffett Truck-Mounted Forklift is inspected/visited at least quarterly in each year. The type of service carried out depends on the environment that the machine is working in. It is very important to note that even though the Moffett Truck-Mounted Forklift may not be operated regularly it is carried on the rear of a truck/trailer and is subject to the harsh environment of driving on roads/motorways, i.e. road salt, rain snow etc. If you require any additional service information and/or clarification of the above please contact your nearest Moffett truck-mounted forklift Service Partner/Dealer or Moffett Engineering Ltd. directly.

**When using compressed air ensure that relevant PPE(Personal Protection Equipment)/Safety equipment is used at all times. Adhere to all Company/Manufacturer safety information and guidelines.**

**Note:** When carrying out maintenance/service work always use Klüberpaste® on pins, bearing stubs, 4-way swivels, steering collars etc. Refer to the Moffett service manual for further details.

## 6. MAINTENANCE

### Introduction

In order to attain full benefit and service from your Moffett Truck-Mounted Forklift, it is important that the following service information/service guidelines are fully adhered to at all times. Moffett Engineering Ltd. recommends servicing take place at the following intervals:

1. Service at 50hrs or 60 days.
2. Next Service at 200 hours or 240 days and every subsequent 200 hour or 240 day intervals (200hrs, 400hrs, 600hrs, 800hrs / 240days, 480days, 720days etc.).
3. Additional items required at 1000 hrs or 1200 days (Refer to table 2 for information, items marked with an \*).

Table 1 (see page 68) shows all the items/operations that require attention/inspection at each service. Each operation has a code indicating the type of action required. Table 1 shows the codes and there relevant terminology.

**Note:** As well as these service items it is recommended that you carry out a through daily maintenance as outlined from page 70



### CAUTION:

The following outlines the recommended preventative maintenance schedule at 50, 200 and 1000 hour or 60, 240 and 1200 day intervals.

Always adhere to the recommended operating and maintenance procedures.

Only trained, authorized and experienced personel should be allowed to operate the Moffett Truck-Mounted Forklift. Service personel should read and study this manual, the service manual, the preventative maintenance and parts manual in order to gain a thorough understanding of the unit prior to making any repairs. Exercise all necessary safety precautions when preforming maintenance covered in the preventative maintenance manual. Ensure that the engine is switched off, the battery is disconnected and the engine and exhaust are cool.

## 6. MAINTENANCE

<b>Maintenance Specifications Chart</b>	
<b>Code</b>	<b>Operation</b>
CH	Change
CK	Check
G	Grease
CL	Clean
D	Drain
A	Adjust

Table 1

<b>SERVICE DETAILS</b>			
Operation	First Service at 50 Hrs or 60 days	Next Service at 200 Hrs or 240 days and every additional 200 Hrs or 240 days	* Additional Items required at 1000 Hrs or 1200 days
Change engine oil & oil filter element	CH	CH	
Change engine air filter element	CK	CH	
Change inline & main fuel element	CH	CH	
Change hydraulic filter elements (suction/return)	CH	CH	
Change hydraulic intank filter elements			CH
Change hydraulic oil			CH
Check/replenish coolant	CK	CK	
Check all bolts/nuts/fittings for tightness	CK/A	CK/A	
Check fan belt tension	CK/A	CK/A	
Carry out full electrical operational checks	CK	CK	
Carry out full hydraulic operational checks	CK	CK	
Adjust and lubricate lift chains	CK/A	CK/A	

## 6. MAINTENANCE

Operation	First Service at 50 Hrs or 60 days	Next Service at 200 Hrs or 240 days and every additional 200 Hrs or 240 days	* Additional Items required at 1000 Hrs or 1200 days
Grease all moving parts manually at specific grease points	G	G	
Check all wheel nuts for tightness (see Wheel Nut Specification Chart)	CK/A	CK/A	
Check all mast/carriage bearings for operation/wear	CK/A	CK/A	
Check rear arm bearings/bushings for operation/wear	CK/A	CK/A	
Check condition of tyres/rims	CK	CK	
Check for play in mast sections/carriage section	CK	CK	
Check mast lift chains for wear/missing parts/elongation	CK/CH	CK/CH	
Check/inspect condition of forks	CK	CK	
Check/inspect condition of seat/seat belt/overhead guard	CK	CK	
Check/inspect machine for all safety/functional decals	CK	CK	
Check oil cooler operation (if fitted)	CK	CK	
Test drive machine with/without weight	CK	CK	
Check transport lights on Moffett truck-mounted forklift with parent Truck/Trailer	CK	CK	
Inspect stabilizing chains for wear/missing/broken parts	CK	CK	
Check engine idling speed	CK/A	CK/A	
Check/adjust valve clearance on engine			CK/A
Remove radiator and clean all dust etc from between fins			CK/CL

## 6. MAINTENANCE

### Daily Maintenance

Before you begin your work-day, take time to check your machine and make certain that all its systems are in good operational condition.

- Check for broken, missing or damaged parts.
- Check the forks, mast and lift chains.
- Check all hydraulic hoses and connections.
- Check the wheels for any damage or for missing or loose wheel nuts.
- Check the tyres for cuts, bulges, tread depth and proper inflation pressure.
- Check the engine oil level. Add oil if required (see section Service Specification, Engine Oil).
- If any parts are not ok contact your supervisor.  
If operating in a dusty or sandy environment; Clean engine air filter element and replace if necessary.

- Clean all dust etc. from between radiator fins. Remove filter mesh from radiator and/or oil cooler where fitted and clean thoroughly. Where necessary, remove radiator for proper cleaning.
- Lift the engine cover and check the engine coolant level on the expansion bottle. Fill to the proper level if necessary. The proper coolant level is just below the radiator cap. Do not remove the radiator cap when the engine is hot. Escaping steam could cause severe burning (see section Service Specifications, Engine Coolant).
- Check the fuel level and top up if necessary.
- Check hydraulic oil level sight glass. Oil level must be between the red line (minimum) and the black line (maximum) when the reach device is fully retracted and all hydraulic cylinders are in the

closed position. Top up if necessary (see section Service Specification, Hydraulic Fluid).



#### **CAUTION:**

Always turn off the engine and allow it to cool before checking:

- Engine coolant level
- Engine oil level
- Hydraulic oil level



#### **CAUTION:**

The hydraulic tank is pressurised and hydraulic oil may be hot. To avoid injury when removing the cap, stop the engine and remove the cap very slowly to avoid spillage.

## 6. MAINTENANCE

### Interlocking seatbelt

**Inspect the seat belt regularly to check for damage and to make sure it functions properly mechanically and electrically.**



#### **WARNING**

- Failure to properly inspect & maintain the seat belt can cause serious injury or loss of life in an accident.
- When being driven if the Moffett Truck-Mounted Forklift is involved in an accident the whole seatbelt assembly must be replaced. This is to ensure that if any unseen damage has occurred it is replaced.
- If the seatbelt is worn or damaged it must be replaced.

- The seatbelt must be inspected in detail at least once a year and more often if exposed to harsh conditions.
- If replacement of any part of the seatbelt is required then the entire assembly must be replaced (Retractor and Buckle) with Moffett Engineering Ltd. recommended items from a service provider.

#### **Inspection**

The following guidelines detail how to inspect the Seat Belt fitted to a Moffett Truck-Mounted Forklift:

**1. Webbing** - To check the webbing pull the seatbelt completely out of the retractor and inspect the full length for deterioration. The Seatbelt must be replaced if it has any signs of nicks, cuts or holes, is frayed or fluffed at the edges, shows excessive fading due to UV exposure, if the webbing is packed

with dirt or if the stitching is frayed, insecure, incomplete or repaired.

**2. Buckle Operation** - Check buckle for damage and check the latch for correct operation. Also determine if the latch plate is excessively worn, deformed or buckle is damaged or casing is broken. Check security and operation by connecting the buckle and tongue, then try to pull apart; while pulling, press button to ensure correct release. Make sure the button does not stick after release.

**3. Retractor** - Fully extend the webbing to determine if the retractor spools in and out correctly. All webbing must retract back fully into the retractor. When the webbing is quickly pulled from the retractor the belt should lock automatically.

## 6. MAINTENANCE

**4. Connection to Forklift** - The seatbelt anchorage points should be checked to ensure all bolts are tight. Check the mounting plates are OK and in the case of the flexible cable type seat belt, ensure that the cable is not broken or frayed.

### 5. Electrical Connection

The seat belt is fitted with an electrical connection and wired to the machine, check that the wire is not cut, pinched or damaged in any way and ensure when seatbelt is disconnected that the machine will not drive.

If the inspection finds any damage, wear, or malfunction of the seatbelt, the complete unit must be replaced with OEM recommended equipment. The seatbelt fitted has been designed and tested specifically for the Moffett Truck-Mounted Forklift. Care must be taken when replacing parts to ensure that they are fitted correctly to

maintain the integrity and function of the Seat Belt system.

**Note:** The seatbelt must only be cleaned with warm soapy water; do not use chemical cleaners, bleach or dyes. Contamination with fuel, grease or acid will damage the seatbelt. Do not make any modifications or additions to the seatbelt.



## 6. MAINTENANCE

### DAILY PRE-SHIFT INSPECTION CHECKLIST

#### Visual Checks

The Moffett Truck Mounted Forklift must be parked on a firm level surface in a SAFE ZONE with the keys removed and the park brake engaged. Starting at the operator station, walk around the forklift and complete the following visual checks.

If defects are identified during the pre-shift visual inspection, notify your supervisor immediately.

- 1 **Decals** - no missing, damaged, or faded decals on the forklift.
- 2 **Seat** - must not be loose; vinyl should not be torn.
- 3 **Seat Belt** - The seat belt should extend smoothly and retract fully. The seat belt must not be frayed or worn. The mechanical latch must be fully functional.
- 4 **Side Guard/Latch/Hinges** - should not have any cracks or bends; must open and close smoothly; must positively latch when closed; **should not be removed.**
- 5 **Overhead Guard** - must not be bent, cracked or modified by drilling or welding.
- 6 **Operator Manual/Manual Box** - *Moffett Operator Manual* must be in the manual box at all times.
- 7 **Hydraulic Level Oil Sight Gauge** - check the hydraulic fluid level with all cylinders in the CLOSED position; top off ONLY with the specified hydraulic fluid; if discoloured, inspect oil system.
- 8 **Fuel Level** - top off if necessary; do not overfill tank; ensure that seal on the inside of fuel cap is not damaged.
- 9 **Valve Levers** - should be clean and clear of debris.
- 10 **Left Tilt Cylinder** - Check for leaks at the fitting and glands (where the cylinder rod extends and retracts). Check for scratches and nicks on the cylinder rod. Check the mounts for cracks on either end of the cylinder. Check for missing or loose bolts on the cylinder retaining pins at either end of the cylinder.
- 11 **Left Front Tyre and Wheel** - Look for debris, mud, or binding behind and around the wheel. There should be no missing or loose wheel nuts. There should be no chunks, cuts, or excessive wear on the tyre. Check for proper inflation, REPLACE if the body ply cords are visible, or show any signs of cuts, bulges, or other signs of damage, or has a loss of traction (regardless of tyre tread height). Look for bent or corroded rims.

## 6. MAINTENANCE

### Visual Checks (continued)

- 12 **Sideshift Cylinder**– See #10 Left tilt cylinder.
- 13 **Left Sideshift Pin** - Check for missing or loose bolts on either end.
- 14 **Left Stabiliser** - Check for damage and ensure the wear pads are intact and adjust with shims if necessary.
- 15 **Left Fork** - lock pins should be functional and making positive engagement in fork board; check the top and bottom carriage mountings for cracks and wear; check the fork for bends, cracks, and wear horizontally (along the blade), vertically (along the shank), and at the heel; ensure that both forks are in the same level plane.
- 16 **Mast** - Check that mast is not bent or has any debris; check the bolts on the base of the mast cylinder for tightness.
- 17 **Mast Chains** - All 4 mast chains should be lubricated; there should be no seized links or rotated connecting pins over the entire length of all 4 chains, they should all be adjusted correctly with no slack in chains.
- 18 **Load Backrest** (*if fitted*) -The load backrest should not be bent or loose.
- 19 **Mast Lift Cylinder and Mounts** – See #10 Left tilt cylinder.
- 20 **Hydraulic Hoses and Connections** - Observe any leaks or loose fittings. Look for oil spots on the ground where the forklift has been parked and on the frame of the forklift for the source of a leak.
- 21 **Right Fork** –See #15 Left fork.
- 22 **Right Sideshift Pin** – See #13 Left sideshift pin.
- 23 **Right Stabiliser** – See #14 Left stabiliser.
- 24 **Right Front Tyre and Wheel** – See #11 Left front tyre and wheel.
- 25 **Right Tilt Cylinder** – See #10 Left tilt cylinder.
- 26 **Top Hood** – no broken latches or hinges.

## 6. MAINTENANCE

### Visual Checks (continued)

- 27 **Reach Device** – Check that reach device is not bent or has any debris; check all bolts for tightness.
- 28 **Air Filter Indicator** – Push the spring-loaded button (if fitted) – replace if it does not return.
- 29 **Engine Oil** - mark should be between the minimum and maximum; top off if below minimum.
- 30 **Coolant** – check Min / Max level on the overflow bottle which is connected to the radiator: **Do not attempt to remove the radiator cap if the engine is hot.**
- 31 **Rear Steering Cylinder** – See #10 left tilt cylinder.
- 32 **Rear Tyre and Wheel** – See #12 Left front tyre and wheel.
- 33 **Rear Door** – no broken latches or hinges; air filter rain cap should be in place.

**NOTE: IF DEFECTS ARE IDENTIFIED DURING THE PRE-SHIFT VISUAL INSPECTION, NOTIFY YOUR SUPERVISOR IMMEDIATELY.**

## 6. MAINTENANCE

### Operational Checks

Operational inspections are done by starting the engine, operating all controls, and test driving. Never start a forklift to perform the operational inspections if the visual inspection indicates immediate safety hazards. Constantly monitor the gauges, listening for unusual noises, loose parts, fluid leaks, and unusual conditions. If a problem is suspected, take the forklift out of service and have it inspected and repaired.

- 1 **Noises/Emissions** – no unusual noises and observe engine emissions.
- 2 **Gauges and Indicators** – engine oil light and the battery light should illuminate when the ignition turned on and then go out when the engine is started; preheat indicator (if equipped) should illuminate when preheating and go out after the engine is started; temperature gauge should rise to the safe operating temperature range when operating.
- 3 **Hour Meter** – should “count” as the forklift is operated.
- 4 **Pedals** – depress the accelerator pedal slowly and return to neutral; engine should run smoothly and accelerate/decelerate to idle; drive the forklift forward and backward at low RPM (depressing the forward/reverse pedal fully in each direction) - forklift should respond accordingly; releasing the forward/reverse pedal should stop the Moffett Truck Mounted Forklift.
- 5 **Seat Belt** - The internal electrical isolator switch must be functioning i.e. when the seatbelt is disconnected the drive pedal isolated machine will not drive.
- 6 **Valve Levers** - cycle all controls fully; there should be no free play in the valve levers; look for jerking movement and listen for unusual noises; all levers should return to the centre position (neutral) when released.
  - **Stabilisers** – both stabilisers lower and raise fully.
  - **Mast** – the mast should raise and lower fully and smoothly.
  - **Tilt** – there should be no binding or jerking when tilting the mast fully forward and rearward.
  - **Sideshift** – there should be no binding or jerking when the mast is sideshifted fully left and fully right.
- 7 **Park Brake (ON/OFF)** – the Moffett Truck Mounted Forklift should not move when the park brake is on.

## 6. MAINTENANCE

### Operational Checks (continued)

- 8 **Steering Response** – the steering should be responsive; no excessive free play, jerking, binding, or unusual noises.
- 9 **Diff-Lock (FWD/REV)** – there will be a noticeable drag on the engine when diff-lock is engaged and attempt to drive forward and reverse.
- 10 **Engaging the Lateral 4-Way Mode (4-Way)** – engage the lateral mode, travel to right and left, steering is precise and smooth.
- 11 **Disengaging the Lateral 4-Way Mode (4-Way)** – engage the normal mode, front wheels should return to “straight ahead position”: travel backward and forward.
- 12 **Back-up Alarm** – must be operational; **the back-up alarm should NEVER be disconnected.**
- 13 **Horn** – should be operational; **do not operate forklift if horn does not work.**
- 14 **Work Lights** – all work lights should be operational.
- 15 **Street lights** – all street lights should be operational.
- 16 **Strobe (if fitted)** – should be operational when the ignition is switched to the ON position.

**NOTE: IF DEFECTS ARE IDENTIFIED DURING THE PRE-SHIFT OPERATIONAL CHECK TAKE THE FORKLIFT OUT OF SERVICE NOTIFY YOUR SUPERVISOR AND HAVE IT INSPECTED AND REPAIRED.**

## 6. MAINTENANCE

### Transport Checks

Transport inspections are done by inspecting the mounting kit and then mounting the Moffett Truck Mounted Forklift onto a truck or trailer before making deliveries. Never attempt to mount the forklift to perform the transport inspections if the visual or operational inspections indicate immediate safety hazards. If a problem is suspected with the mounting kit or forklift, take the either the mounting kit or forklift out of service and have it inspected and repaired.

- 1 **Mounting Kit** – Check the mounting kit and chain hanger brackets for cracks and bends.
- 2 **Tie Downs** (*Dump Bed Mounting Kit only*) – The tie downs should be positively locked in place.
- 3 **Pins and Locks** – Ensure that the transport pins on either side are not worn and that both flip locks are working
- 4 **Transport Chains** – Check for damaged or dislodged pins on the end shackles at either end of both chains. The bolts and lock nuts that retain the transport chains on either side of the Moffett Truck Mounted Forklift should be in place. Mount the forklift on the rear of the truck or trailer. **If any unusual noises, jerking, or binding are noticed, immediately lower the forklift to the ground and have it inspected by a forklift technician**
- 5 **Rear Bumper Lights** (*when mounted*) – All rear bumper lights should be working:
  - side marker ( left and right)-2
  - corner marker (left and right)-2
  - back-up x1 or x2
  - stop-2
  - tail -2
  - turn-2

**NOTE: IF DEFECTS ARE IDENTIFIED DURING THE PRE-SHIFT TRANSPORT CHECK TAKE THE KIT OR FORKLIFT OUT OF SERVICE NOTIFY YOUR SUPERVISOR AND HAVE IT INSPECTED AND REPAIRED.**

## 6. MAINTENANCE

### Grease Point Chart

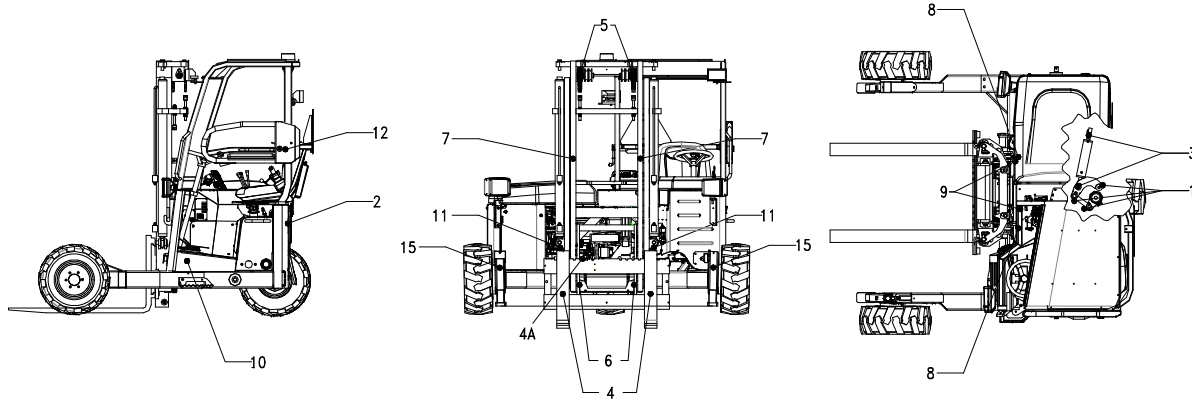

ITEM	DESCRIPTION	No. OF POINTS
1	Steering Linkage	1
2	Spindle Housing	2
3	Steering Cylinder	2
4	Fork Carriage	6
4A	Sideshift Upper Rail	4 (if fitted)
5	Top Chain Rollers	2
6	Bottom Chain Rollers	2
7	Mast Upper Section	2

ITEM	DESCRIPTION	No. OF POINTS
8	Mast Lower Section	2
9	Mast Middle Section	4
10	Tilt Cylinder	4
11	Side Shift Cylinder	2
12	Side Shift Bushing	2
13	Lift Cylinders	2
14	Rotating Side Guard	1
15	Stabilisers	2

## 6. MAINTENANCE

### Steering Linkage, Spindle Housing And Steering Cylinder Grease Points

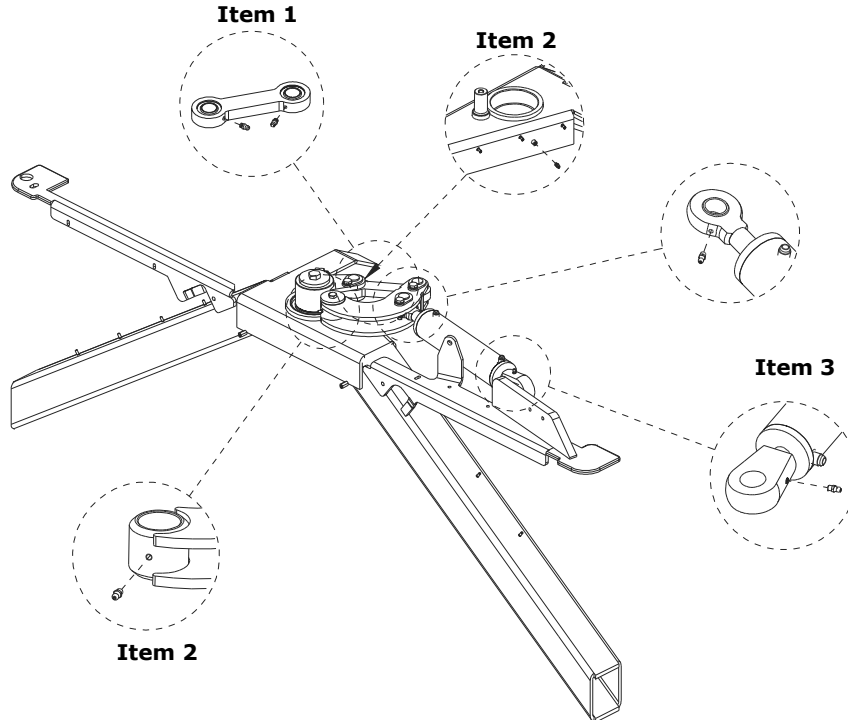



## 6. MAINTENANCE

### Fork Carriage Grease Points

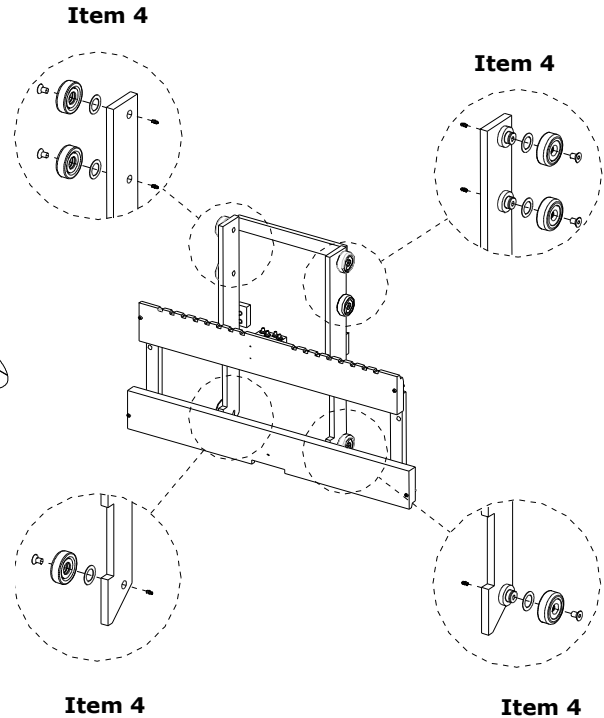
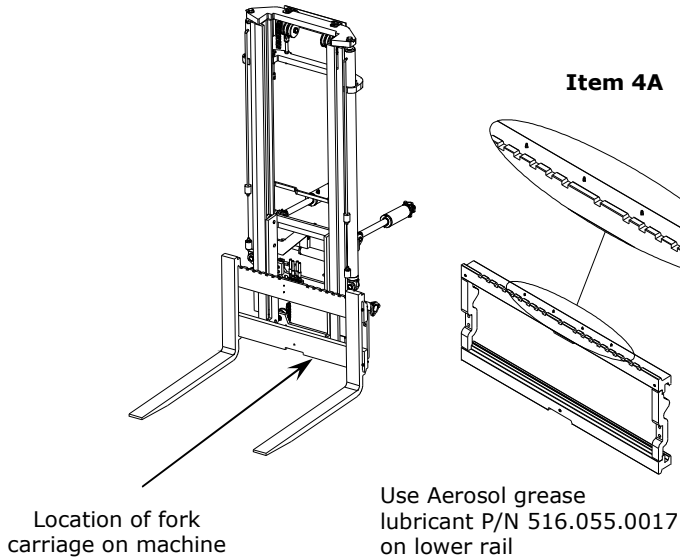

## 6. MAINTENANCE

### Chain Rollers Grease Points

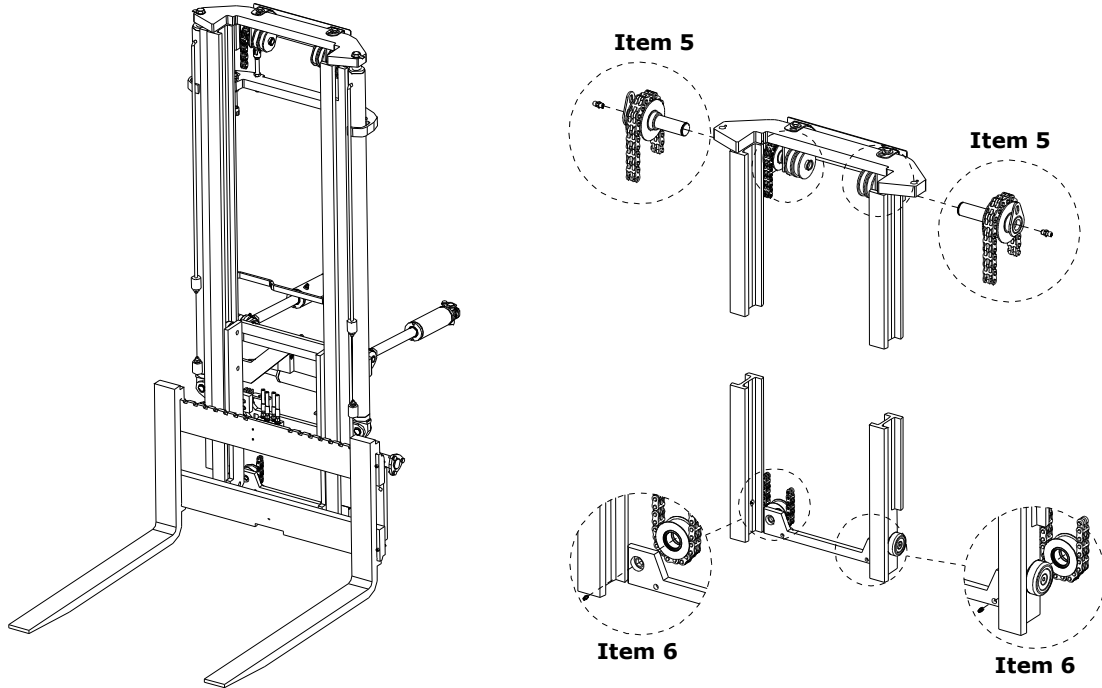

## 6. MAINTENANCE

### Mast Section Grease Points

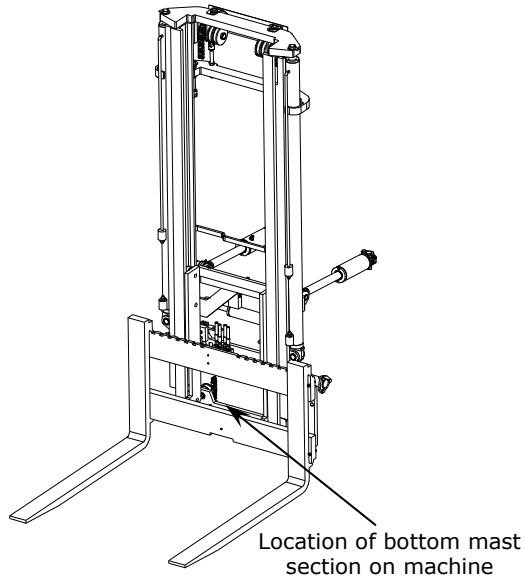

Item 7

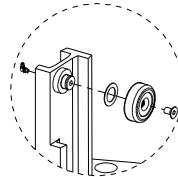

Item 7

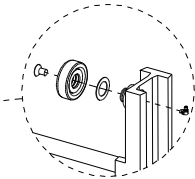

Item 8

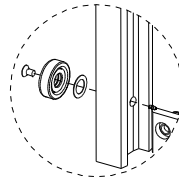

Item 8

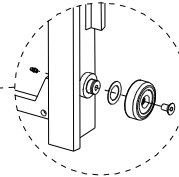

## 6. MAINTENANCE

### Mast Section Grease Points

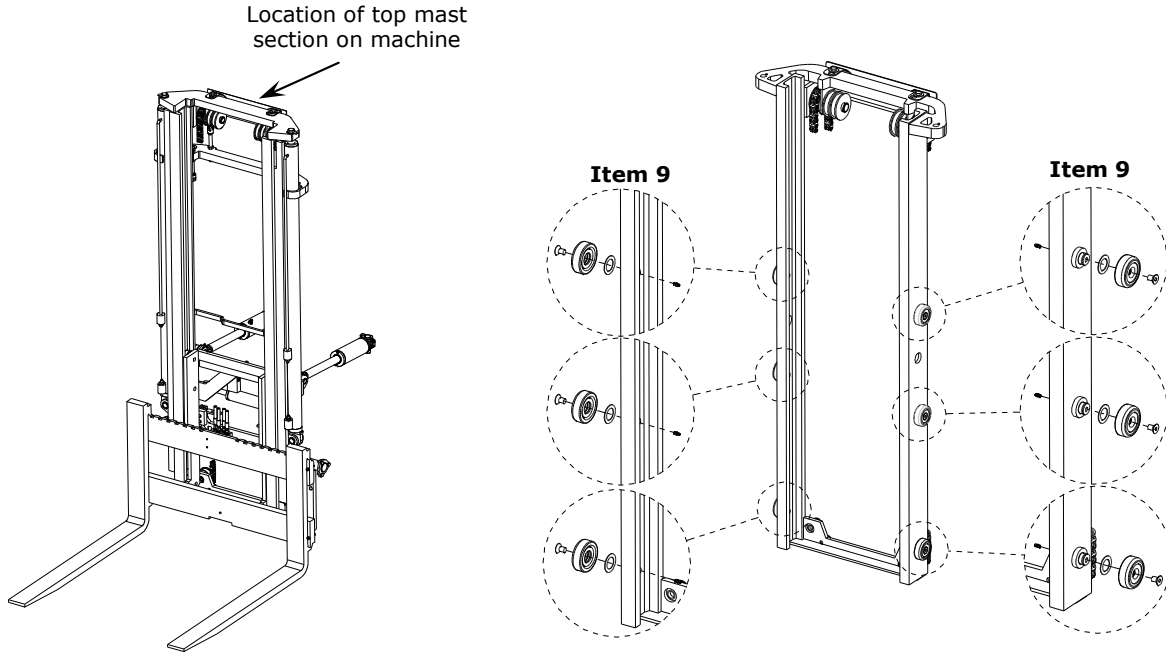

## 6. MAINTENANCE

### Tilt Cylinder Grease Points

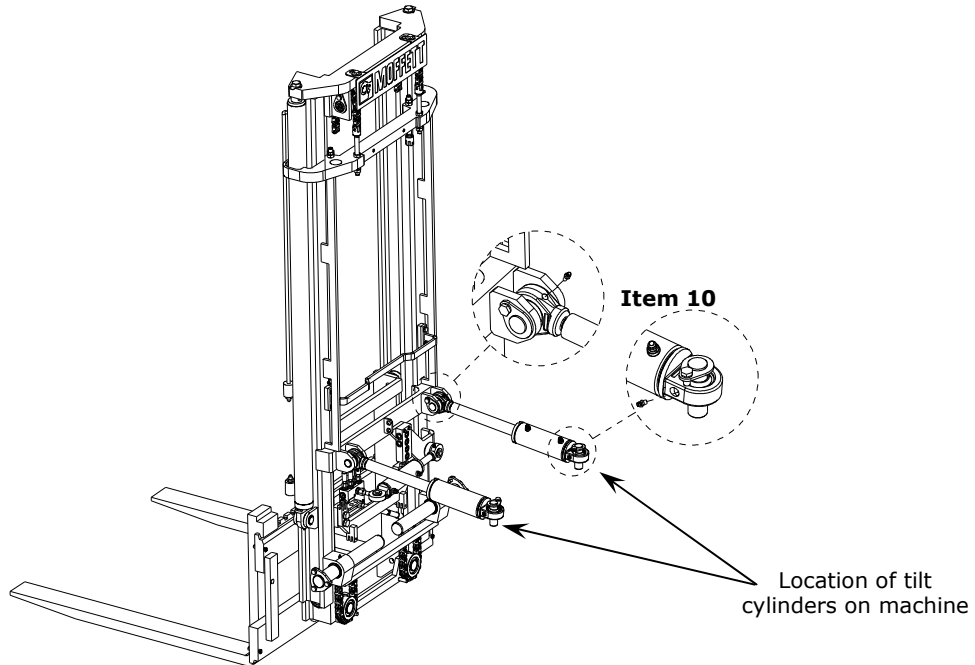

## 6. MAINTENANCE

### Sideshift Cylinder Grease Points

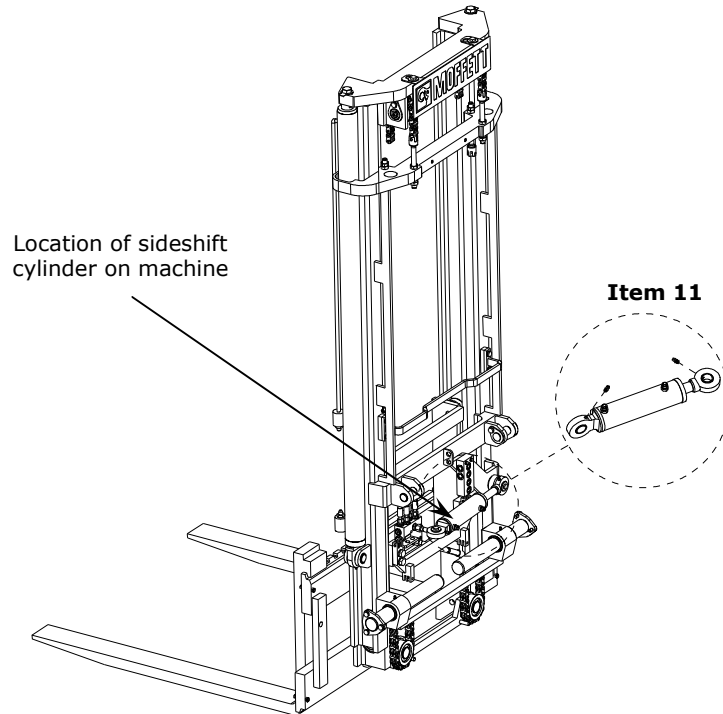

## 6. MAINTENANCE

### Sideshift Bushing Grease Points

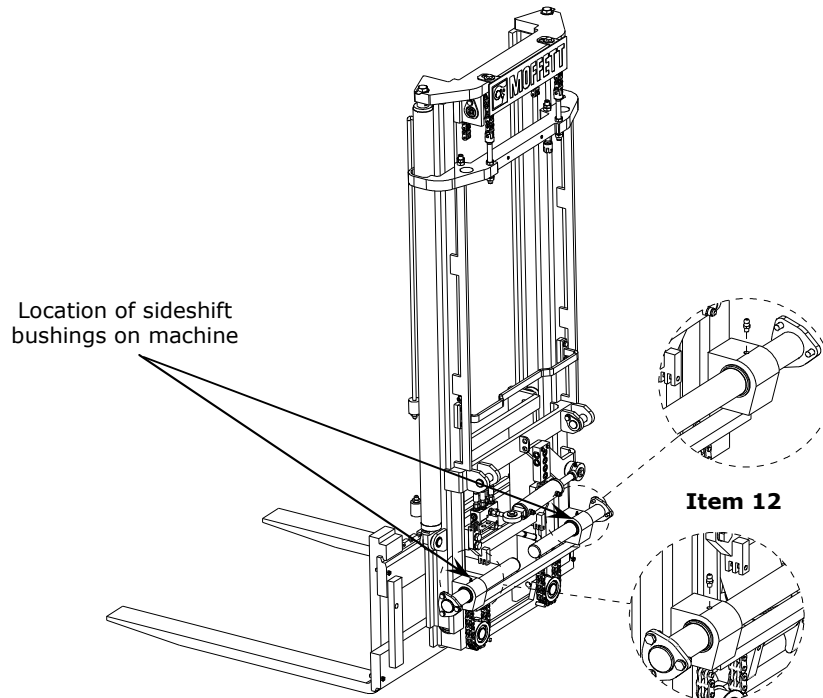

## 6. MAINTENANCE

### Lift Cylinder Grease Points

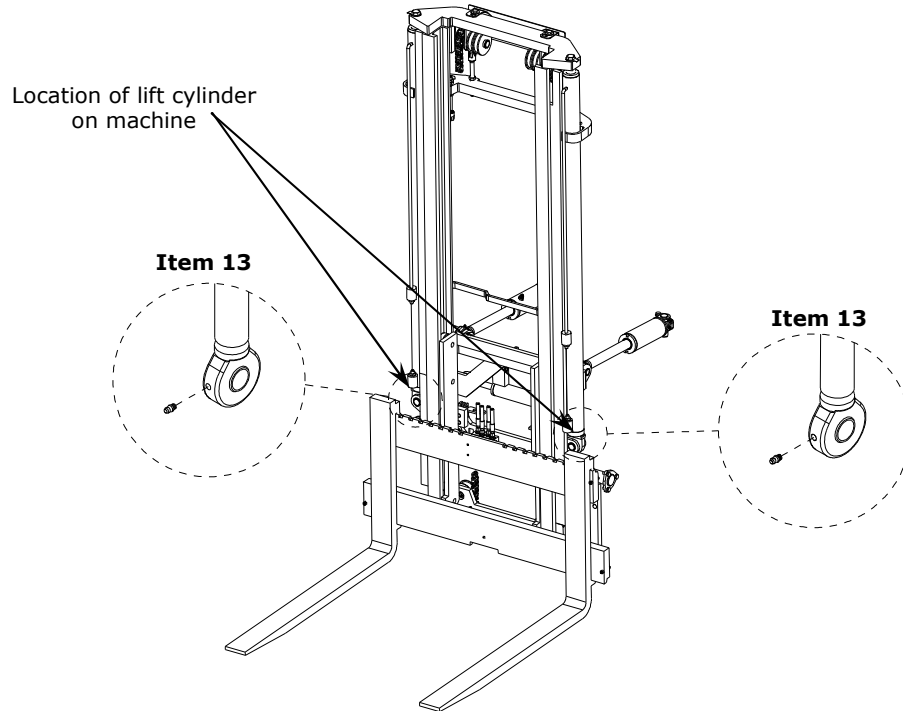



# 6. MAINTENANCE

## Rotating Side Guard

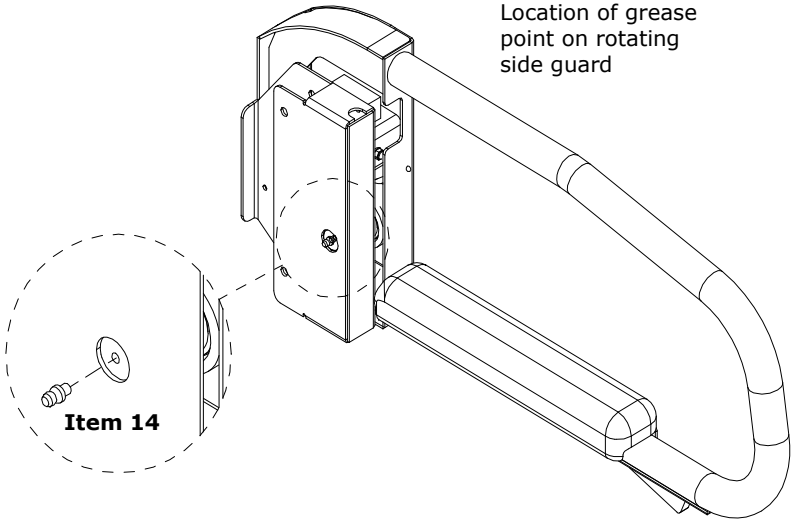

# 6. MAINTENANCE

## Stabiliser Grease Points

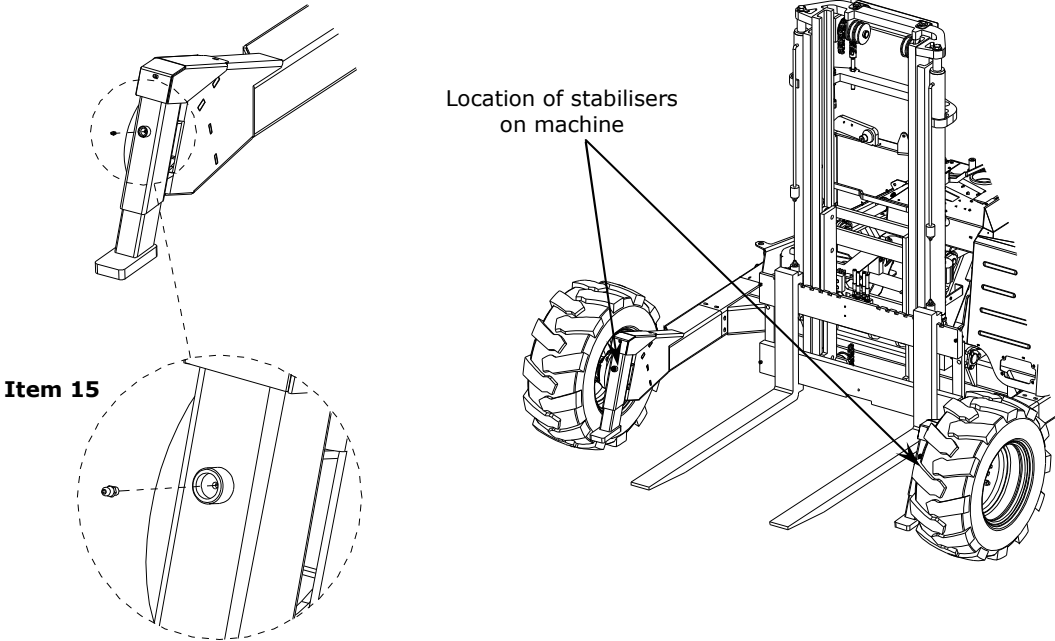

## 6. MAINTENANCE

### Engine Oil

Engine oil should be MIL-L2104C or have properties of API classification grades or higher. Change the type of engine oil according to the ambient temperature.

When using oil of different brands from the previous one, be sure to drain all the previous oil before adding the new engine oil.

AMBIENT TEMPERATURE	OIL SPECIFICATION		
Above 25°C (77°F)	SAE30	Or	SAE 10W-30 SAE 10W-40
0 to 25°C (32 to 77°F)	SAE20	Or	SAE 10W-30 SAE 10W-40
Below 0°C (32°F)	SAE10W	Or	SAE 10W-30 SAE 10W-40

### Engine Coolant

A mix of 50% permanent type antifreeze and 50% distilled water should be used to fill the cooling system. The coolant mix inhibits corrosion and gives the system protection down to -37°C (-35°F). A good quality coolant with a specific gravity of 1.080 at 15.5°C (60°F) should be used. The antifreeze should comply with one of the following specifications:

SAE J1034  
BS 6580: 1985  
MIL - A - 11755D  
MIL - A - 461 53/B

The concentration of the coolant may deteriorate over a period and therefore should be checked at least once a year or at each 200 hour's service whichever whichever occurs first.

## 6. MAINTENANCE

### Engine Fuel Specification

Use No.2-D – a distillate fuel oil of lower volatility for engines in industrial and heavy mobile service. (SAE J313 Jun87) Grade of Diesel Fuel Oil (According to SATM D975). Be sure to use a strainer when filling the fuel tank, as dirt or sand in the fuel may cause trouble in the fuel injection pump. Always use diesel fuel. You are required not to use alternative fuel, because its quality is unknown or it may be inferior in quality. Kerosene, which is very low in cetane rating, adversely affects the engine. Diesel fuel differs in grades depending on the temperature. Refer to the following tables for specific minimum and maximum fuel properties.

Flash Point, °C (°F)	Water and Sediment Volume %	Carbon Residue on, 10% Residium, 1%	Ash, weight %
Min	Max	Max	Max
52 (125)	0.05	0.35	0.01

Distillation Temperature °C (°F) 90% Point		Viscosity Kinematic cSt or mm 2/5 at 40°C		Viscosity Saybolt SUS At 100°F		Sulphur, Weight %	Copper Strip Corrosion	*Centane Number
Min	Max	Min	Max	Min	Max	Max	Max	Min
282 (540)	338 (640)	1.9	4.1	32.6	40.1	0.50	No.3	40

## 6. MAINTENANCE

### Hydraulic Fluid

Oils conforming to the International Standard I.S.O. 6743-4HV VG grade oils with improved viscosity/temperature characteristics should be used. (Some countries may still use DIN 51524 PART 3). The hydraulic oil used in the Moffett truck-mounted forklift must have the correct temperature range for the ambient temperature in which the machine is being operated. If the operating temperature is outside the standard range, the standard oil should be replaced with the correct grade. Some examples of commercially available oils are listed below. Make sure the correct type is used in the relevant ambient environment.

#### Note:

1. The sequence in which the brand names are listed does not signify any grading as to their quality or preference.
2. M50, M4000 and M5000 are supplied with the standard-range hydraulic fluid.
3. P5000 is supplied with the high-range hydraulic fluid.

<b>AMBIENT TEMPERATURE</b>	<b>Low Range -20°C to 25°C -4°F to 77°F</b>	<b>Standard Range -10°C to 35°C 14°F to 95°F</b>	<b>High Range 0°C to 45°C 32°F to 113°F</b>
Castrol: Hysin	AWH 32	AWH 46	AWH 68
BP: Bartran	HV 32	HV 46	HV 68
Esso: Univis	N 32	N 46	N 68
Mobil:	13 M	15 M	16 M
Shell: Tellus Oil	T 32	T 46	T 68
Texaco:	HDZ 32	HDZ 46	HDZ 60

## 6. MAINTENANCE

### Chain Lubricant Specification

The lubricant oil's viscosity should be chosen so that it will remain fluid at all occurring ambient temperatures. Under normal temperature conditions, lubricating oils with a viscosity from SAE 20 to SAE 40 (50 to 2000mm<sup>2</sup>/s at 40°C) are suitable. The following are examples of commercially available chain-lubricating products.

1. Rexnord High-Performance Chain Spray.
2. BP Energol Transmission Oil 80.
3. ESSO Transmission Oil ST80.
4. Shell Tonna Oil T200.

### Grease Specification

The recommended grease for all moving parts is Lithium EP2 or equivalent specification. This is particularly important for all bearings and rollers.

### Tyre Inflation

See chart for recommended tyre inflation pressures used by Moffett Truck-Mounted Forklift.

\*It is recommended that tread depth should never fall below 20% of original tread depth.



### WARNING:

Using compressed air can be dangerous. Obey all statutory notices and apply all relevant health and safety regulations.

Wheel Nut Torque		
Model	Torque	Wheel Nut P/N
M4	200 Nm, 150lbf.ft	503.055.0345

### Specification      PSI(Bar)

#### Rear

21x8-9 (14 ply) - 132(9)  
 23x8.5-12 (6 ply) - 51(3.5)  
 27x12-10 (14 ply) - 102(7)  
 26x12-12 (10 ply) - 66(4.5)  
 10x16.5-15 (8 ply) - 55(3.75)  
 29x12.5-15 (8 ply) - 45(3)

#### Front

18x7-8 (14 ply)-132(9)  
 21x8-9 (14 ply) - 132(9)  
 23x8.5-12 (6 ply) - 51(3.5)  
 26x12-12 (10 ply) - 66(4.5)  
 27x12-10 (14 ply) - 102(7)  
 10x16.5-15 (8 ply) - 55(3.75)  
 29x12.5-15 (8 ply) - 45(3)

#### 4-Way

#### Rear

21x8-9 (14 ply) - 132(9)  
 23x8.5-12 (6 ply) - 51(3.5)  
 26x12-12 (10 ply) - 66(4.5)  
 27x12-10 (14 ply) - 102(7)  
 10x16.5-15 (8 ply) - 55(3.75)  
 29x12.5-15 (8 ply) - 45(3)

#### Front

21x8-9 (14 ply) - 132(9)  
 23x8.5-12 (6 ply) - 51(3.5)  
 26x12-12 (10 ply) - 66(4.5)  
 27x12-10 (14 ply) - 102(7)  
 10x16.5-15 (8 ply) - 55(3.75)  
 29x12.5-15 (8 ply) - 45(3)

## 6. MAINTENANCE

### Noise Data

#### Noise (In accordance with EN12053)

The figures below are a combination of the values for the operating modes "DRIVE", "LIFT" and "IDLE" weighted with a proportion factor and is made in accordance with EN12053, 1997

- |    |                      |             |
|----|----------------------|-------------|
| 1. | Sound Power Level    | 107 LWA dB  |
| 2. | Sound Pressure Level | 84.7 LPA dB |

The figure below is a guaranteed sound power level to ISO4871, 1996

- |    |                              |            |
|----|------------------------------|------------|
| 1. | Guaranteed Sound Power Level | 107 LWA dB |
|----|------------------------------|------------|

### Vibration Data

#### Vibration (In accordance with EN13059)

Weighted rms Acceleration Whole Body Vibration ( $m/s^2$ )	1.35
Weighted rms Acceleration Hand-Arm Vibration ( $m/s^2$ )	2.57

## 7. SPECIAL PROCEDURES

### Jump Starting

#### Safety



#### **WARNING**

If you are unsure how to follow this procedure, we strongly recommend that you seek help of a competent mechanic.

Batteries contain sulphuric acid which is poisonous and corrosive. Wear protective safety glasses when jump starting, and avoid spilling acid on your skin, clothing or vehicle.

Do not try to charge a frozen battery. If you try to charge a frozen battery, or jump start and run the engine, the battery could explode.

Do not use the battery if the electrolyte is frozen. To prevent the battery electrolyte from freezing, keep the battery at full charge.

Do not smoke when checking the battery electrolyte levels. Batteries give off a flammable gas that can explode. When starting another machine, make sure the two machines do not touch as this could cause sparks. Sparks could ignite the battery gas. If this happens the battery could explode.

Even with the starter switch set to the off position some circuits will still be energised when the external power supply is connected. Ensure all machine switches are set to the off position before connecting the external power supply.

Only use jump start cables that are in good condition with securely attached connectors.

Connect both ends of one jump start cable before connecting the other cable.



#### **CAUTION:**

The booster supply should not be more than 12 volts. Using a higher voltage supply will damage your machines electrical system. Do not connect two batteries together to give 24 volts. This could burn out the induction manifold heater and damage the starter motor.



#### **WARNING:**

Keep all metal straps and fasteners from clothes or jewelry clear of the positive terminal (+) battery terminal. Such items can cause a short between the battery terminal and nearby metal framework. If this happens you could get burned.



## 7. SPECIAL PROCEDURES

### Jump Starting (continued)

#### Procedure

Note: Your machine has a 12 volt starting system. The negative terminal (-) is connected to the engine cylinder block.

- A) Make sure that the park brake is engaged and the forward / reverse pedal or lever is in neutral.
- B) Ensure all switches are set to the off position.
- C) Open the bonnet / hood.
- D) Connect the positive cable to the positive terminal. Connect the other end of this cable to the positive (+) end from the booster supply.
- E) Connect the negative (-) cable to the ground terminal. The engine mount bolts are easily accessible as a ground point.
- F) Connect the other end of the negative cable to the negative (-) terminal from the booster supply.
- G) Start the engine. (Refer to Starting the Engine)
- H) Disconnect the negative (-) booster cable from the Moffett, then dis-connect it from the negative terminal. Disconnect the positive (+) terminal from the jump start point on the Moffett then disconnect it from the positive terminal.
- I) Close and lock the bonnet / hood.

## **8. ATTACHMENTS**

### **Using other Attachments**

The Moffett Truck Mounted Forklift is available with a range attachments fitted from the factory. The general rule is that any attachment used on this forklift must be intended for the function of lifting only. This forklift is not designed to PULL, TOW or DRAG other objects. DO NOT use attachments that perform these functions with this forklift.

All Moffett machines supplied with attachments have special capacity charts taking into account any additional attachment weight and lost load centre and how this affects the stability and capacity of the machine. Third party suppliers may not supply this information with their attachments and so only approved attachments must be fitted to the Moffett Truck Mounted Forklift.

Moffett makes no representations or warranties, express or implied, as to the design, manufacture or fitness for use with this forklift of any third party source attachments.

This forklift is not intended to be used and should not be used with any attachment that would alter the centre of gravity stability of this forklift. Moffett assumes no liability for any third party attachment that would alter the centre of gravity stability.

If in doubt contact your local Moffett dealer for advice.





# Operator Manual

## Moffett Truck Mounted Forklift With Pantograph & Telescopic Forks

**Note:**

This section of the manual describes additional operating instructions for the Moffett Truck-Mounted Forklift Pantograph Reach Device unit and should only be used as a supplement to the operator manual.

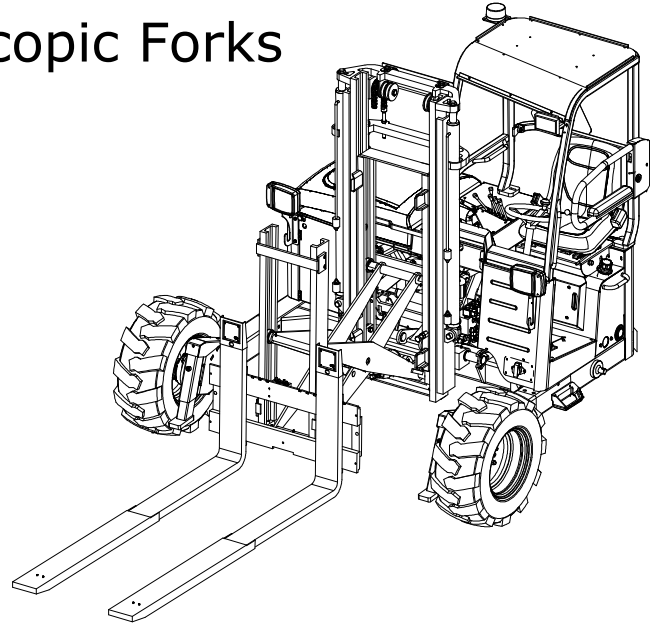

Delivering **Confidence**

## B1. SAFETY CHECKLIST – PANTOGRAPH & TELESCOPIC FORKS

### Safety Checklist

**Note:** The additional Safety Checklist in this section is specific to Pantograph and telescopic forks. This should be used in conjunction with the Safety Checklist for the standard machine as outlined at the start of this manual.



#### **CAUTION:**

**Truck Mounting.** Never truck mount with the Pantograph or telescopic forks extended. Always truck mount with the Pantograph and telescopic forks retracted as outlined in the normal mounting procedure.

## B2. INTRODUCTION – PANTOGRAPH & TELESCOPIC FORKS

### Major Components

1. Telescopic Forks
2. Pantograph Device
3. Scissor Cylinder.
4. Pantograph Mast.
5. Lift Rams x2.
6. Hydraulic Controls.

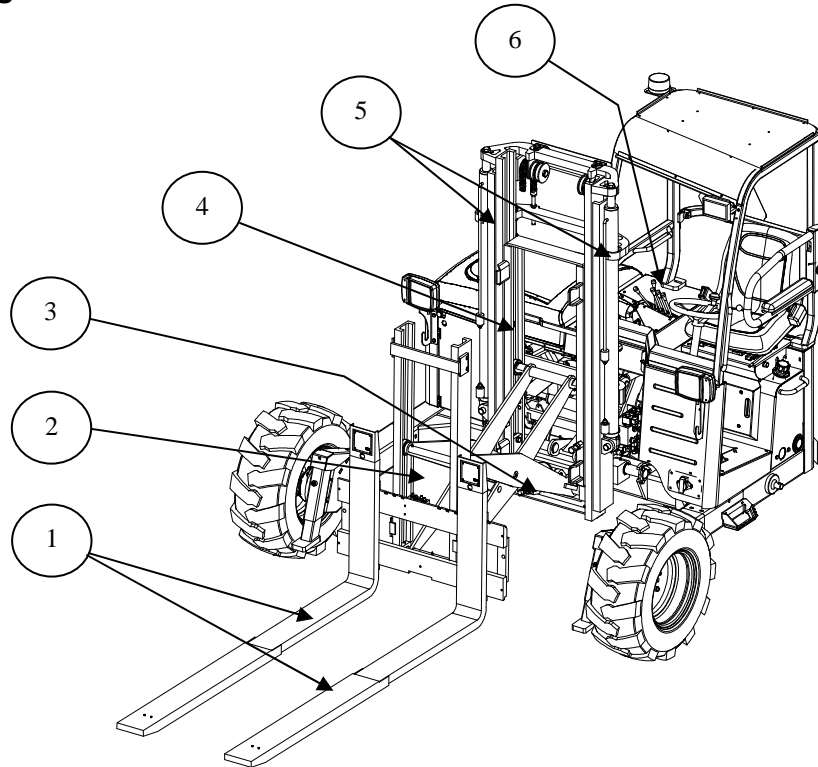

## B2. INTRODUCTION – PANTOGRAPH & TELESCOPIC FORKS

### Safety Decals

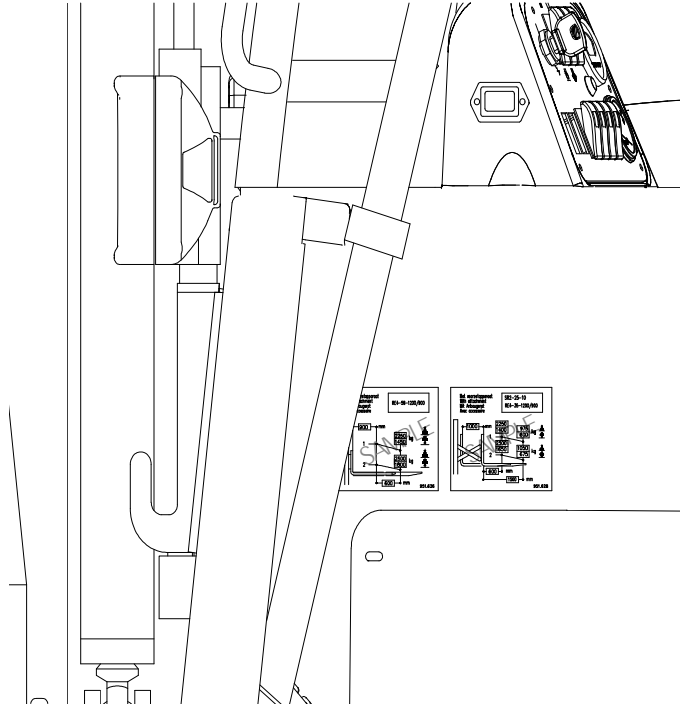
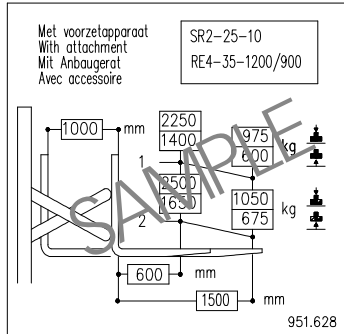
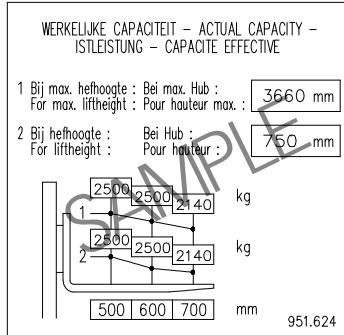

## B2. INTRODUCTION – PANTOGRAPH & TELESCOPIC FORKS

### Safety Decals (continued)

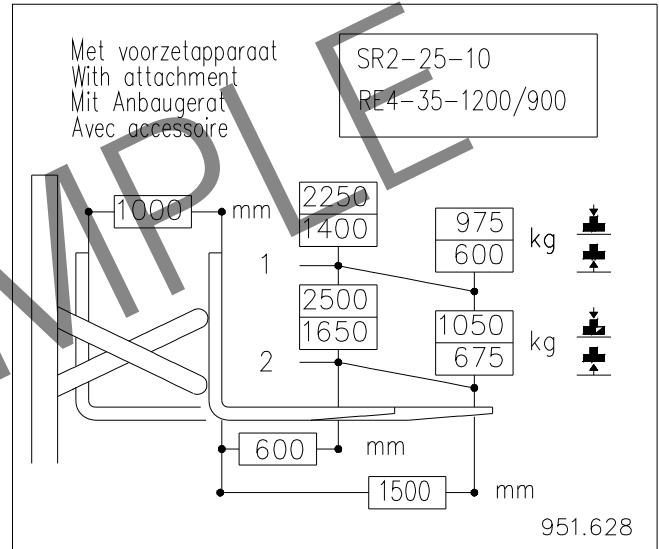
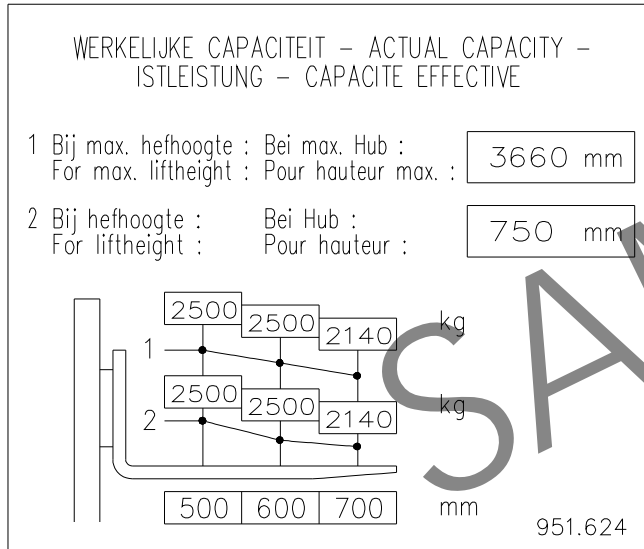



## B2. INTRODUCTION - PANTOGRAPH & TELESCOPIC FORKS

### Safety Decals (continued)

**Note:** The additional Safety Decals listed in this section are specific to Lift Assist and Pantograph and should be used in conjunction with the Safety decals on the standard machine.

Part No. 517.130.0006

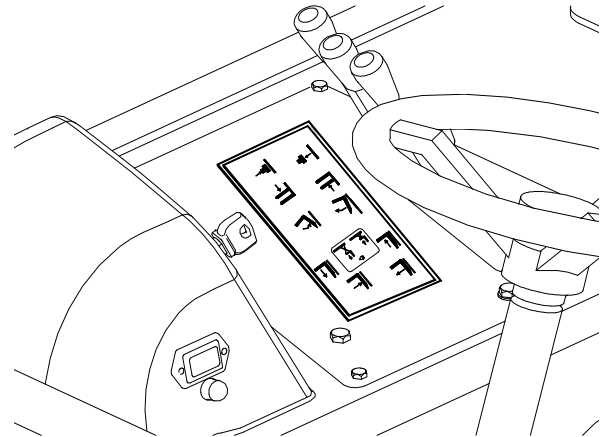
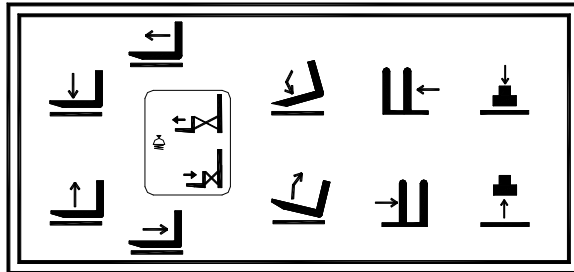

**Note:** The valve bank and load chart decals in this section are only examples and may differ from those found on your machine.

## B2. INTRODUCTION - PANTOGRAPH & TELESCOPIC FORKS

### Safety Decals (continued)

**Note:** The additional Safety Decals listed in this section are specific to Pantograph reach device and should be used in conjunction with the Safety decals on the standard machine.

**Note:** Additional Decal ENG011 also on RH side but not shown.

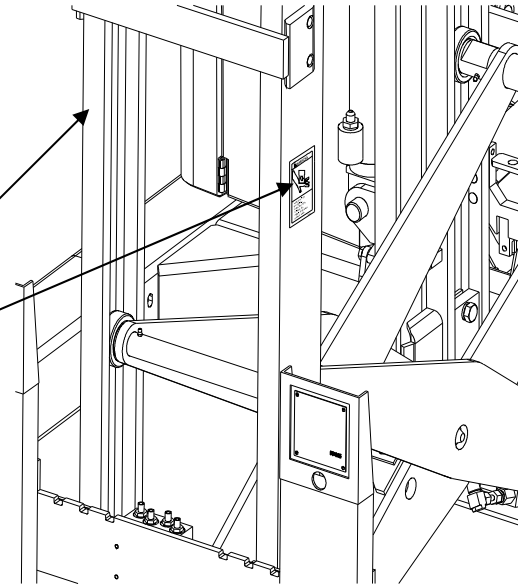
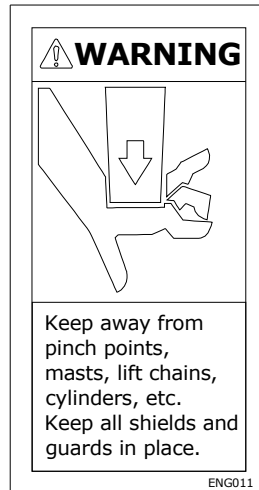

## B2. INTRODUCTION - PANTOGRAPH & TELESCOPIC FORKS

### Instruments And Controls Hydraulic Levers

The Pantograph and Telescopic forks machine is fitted with a dual function lever. The function of this lever is outlined below and on the Valve Bank Decal.

#### **UNDERSTAND THE FUNCTION OF BOTH LEVERS FULLY BEFORE OPERATING THE MACHINE!**

##### **A. Forks – Raise and Lower:**

This lever raises and lowers the forks. Forward movement of the lever will lower the forks (down). Backward movement of the lever will raise the forks (up).

##### **B. Pantograph or Telescopic Forks:**

This lever is fitted with a button which gives the lever two functions **B1** and **B2**.

##### **B1. Pantograph – Extend and Retract**

Without the red button pressed (**off**) this lever moves the Pantograph forwards and backwards. Forward movement of the lever extends the pantograph forward, away from the operator (out). Backward movement of the lever retracts the pantograph backward towards the operator (in). When placing a load, the pantograph should be extended only when the stabilisers are fully lowered.

##### **B2. Telescopic Forks – Extend and Retract**

With the red button Pressed (**on**) pushing the lever forward will extend the telescopic forks (out). Pressing the button (**on**) and pulling the lever backwards will retract the telescopic forks (in).

##### **C. Tilt Mast – Forward and Back:**

This lever tilts the mast forwards and backwards. Forward movement of the lever tilts the mast forward (Forks Down). Backward movement of the lever tilts the mast rearward (Forks Up). Loads should normally be transported with the mast tilted back.

**D. Side-Shift:** This lever moves the mast to the right or left. Forward movement of the lever shifts the mast to the left. Backward movement of the lever shifts the mast to the right.

## B2. INTRODUCTION - PANTOGRAPH & TELESCOPIC FORKS

### Hydraulic Levers (continued)

#### E. Stabilizers – Lower and Raise:

This lever raises and lowers the stabilizing legs. When placing a load, the stabilizers must always be fully lowered before moving the mast forward. Moving the lever forward will lower the stabilizers (down). Moving the lever backwards raises the stabilisers (up). When lifting a load, never raise the stabilisers until the mast is fully retracted.

**Note:** When the ground is not firm enough to support the stabilisers extra support plates must be used of sufficient size and strength to ensure they do not sink, bend or buckle during operation. A second person may be required to check the support plates. If at any time the stabilisers or pads show sign of sinking the procedure must be stopped immediately, the reach device fully retracted and an alternative location found. If in doubt prior to or during an operation on loose, uneven or soft surfaces, stop. Always consider safety first.

**Note:** If during the lifting operation the stabilisers start to slip the load must be lowered immediately and a smaller load – load centre lifted or improved ground conditions found.

## B2. INTRODUCTION - PANTOGRAPH & TELESCOPIC FORKS

### Hydraulic Levers (continued)

#### VALVEBANK DECAL - FUNCTIONS

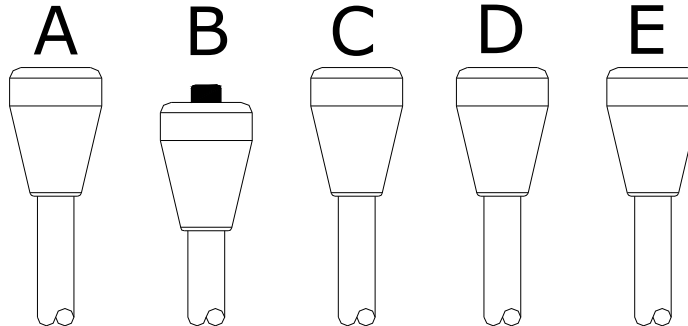
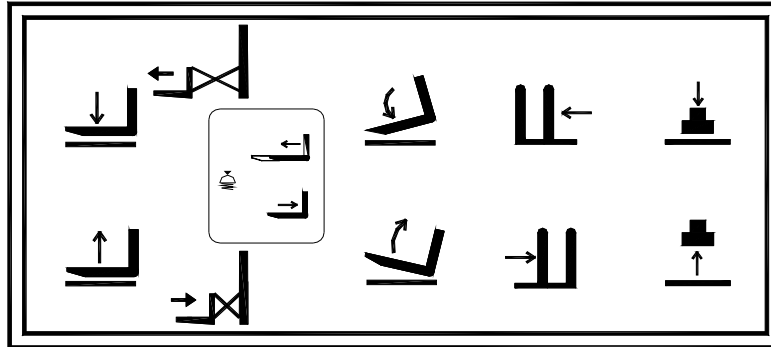

## B3. OPERATING PROCEDURE - PANTOGRAPH & TELESCOPIC FORKS

### Operating Pantograph and Telescopic Forks

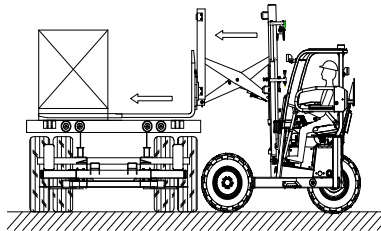
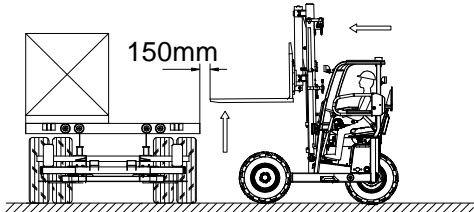
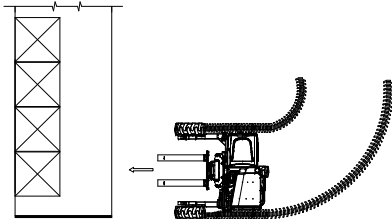

**Note:** These procedures are in addition to the operating procedures outlined for the standard machine in Section 4 of this manual.

1. Align the forklift and the forks with the centre of the load.
2. Approach at 90 degrees to the truck/trailer bed with the forks as low as possible.
3. Drive forward slowly until the tip of the forks are approximately 150mm from the truck or trailer bed.
4. Tilt the mast forward to the vertical position and raise the forks to bed height.
5. Drive forward as far as possible without the mast making contact with the bed.
6. Do not contact the tyres or any part of the truck or trailer with the stabilisers.
7. Extend the pantograph fully to engage the pallet.
8. When the pantograph is fully extended. Press the micro switch on top of the lever and push the lever forward to extend the telescopic forks to fully engage the pallet.
9. Ensure the surface is firm and level and then LOWER the stabilisers fully.
10. Never lower the stabilisers near the edge of a curb because they may slip off the edge or the edge may break away. Double fork the load if necessary.

### B3. OPERATING PROCEDURE - PANTOGRAPH & TELESCOPIC FORKS

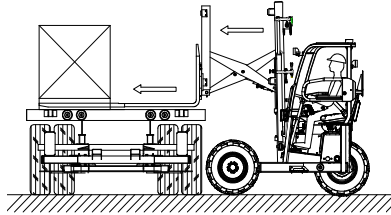

11. Raise the load slowly just enough to clear the bed.



#### **WARNING:**

Do not lift the load more than 100mm clear of the bed while the pantograph is extended.

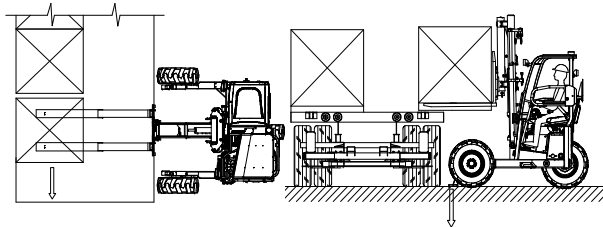

12. Sideshift enough to clear the adjacent pallet or headboard.
13. Retract the telescopic forks fully.
14. Double fork if necessary to ensure load is in contact with fork face.
15. Tilt the mast rearward enough to stabilise the load.
16. Retract the pantograph fully.

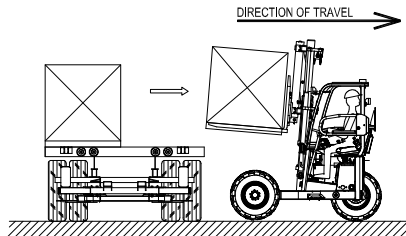

17. Raise the stabilisers fully.

### B3. OPERATING PROCEDURE - PANTOGRAPH & TELESCOPIC FORKS

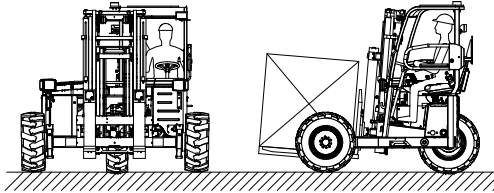

18. Ensure the rear wheel is pointing straight ahead.
19. Reverse straight back to clear the truck or trailer bed (looking in the direction of travel).

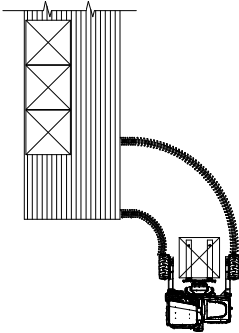

20. Lower the load to a level just above the frame.
21. Sideshift the mast to the centre position.
22. Lower the load as low as possible within the frame.

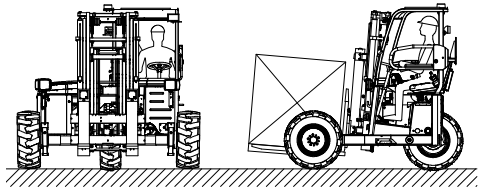

23. Turn the forklift in the intended direction of travel.
24. Slowly drive away – looking in the direction of travel.



## B4. MOUNTING PROCEDURE – PANTOGRAPH & TELESCOPIC FORKS

Mount as per standard machine (See section 5)

**NEVER MOUNT THE MACHINE USING THE PANTOGRAPH ALWAYS ENSURE THE PANTOGRAPH IS FULLY RETRACTED.**

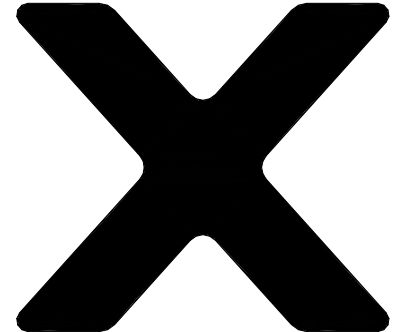
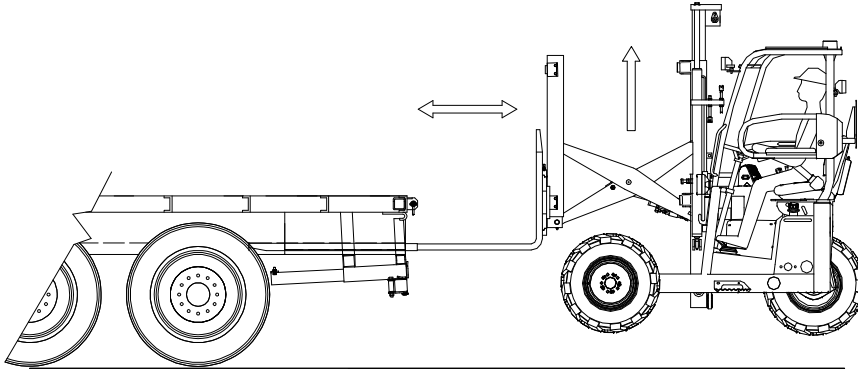

## B5. MAINTENANCE - PANTOGRAPH & TELESCOPIC FORKS

### Grease Points

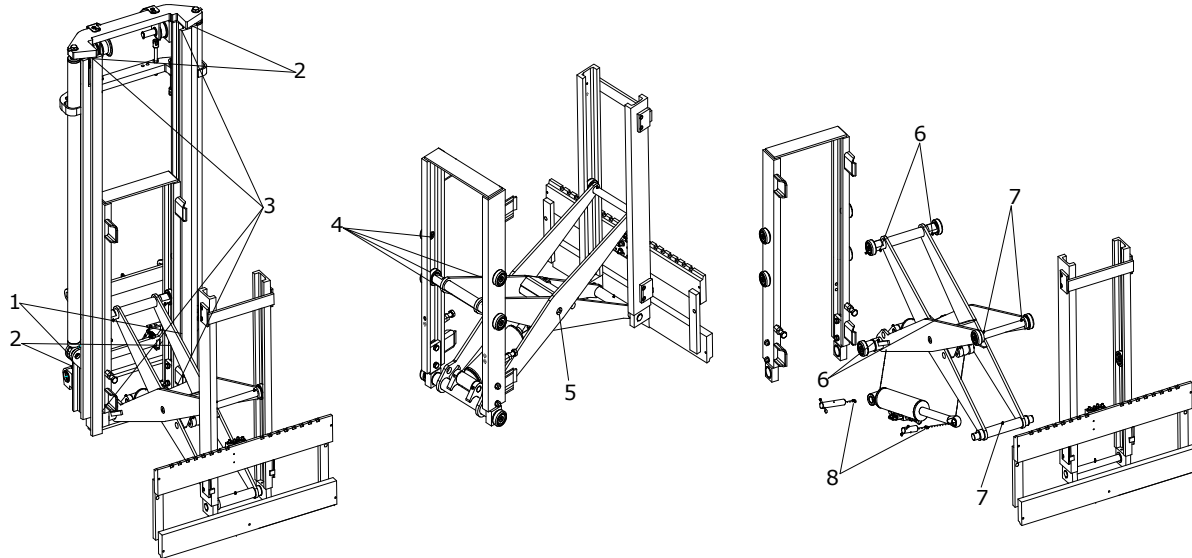

ITEM	DESCRIPTION	No. OF POINTS	PAGE NUMBER	ITEM	DESCRIPTION	No. OF POINTS	PAGE NUMBER
1	Lift Cylinders	2	114	5	Scissor Middle Section	1	118
2	Mast Outer	4	115	6	Scissor Rear Section	4	119
3	Mast Inner	6	116	7	Scissor Front Section	3	120
4	Pantograph Mast	4	117	8	Pantograph Cylinder Pins	2	121

## B5. MAINTENANCE – PANTOGRAPH & TELESCOPIC FORKS

### GREASE POINTS ON LIFT CYLINDERS

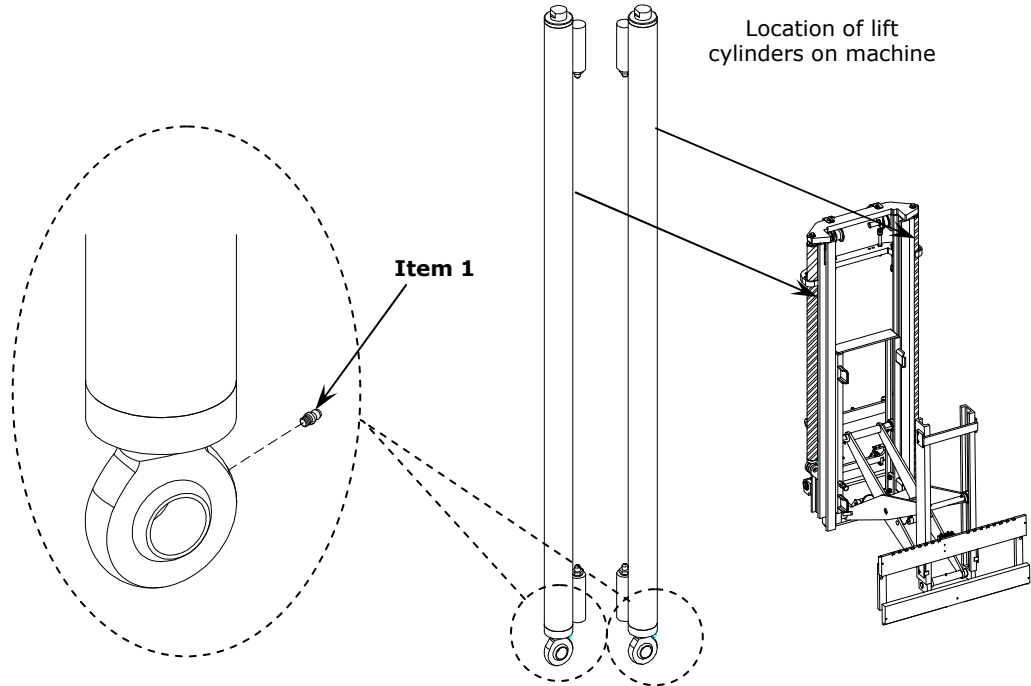

## B5. MAINTENANCE – PANTOGRAPH & TELESCOPIC FORKS

### GREASE POINTS ON MAST OUTER SECTION

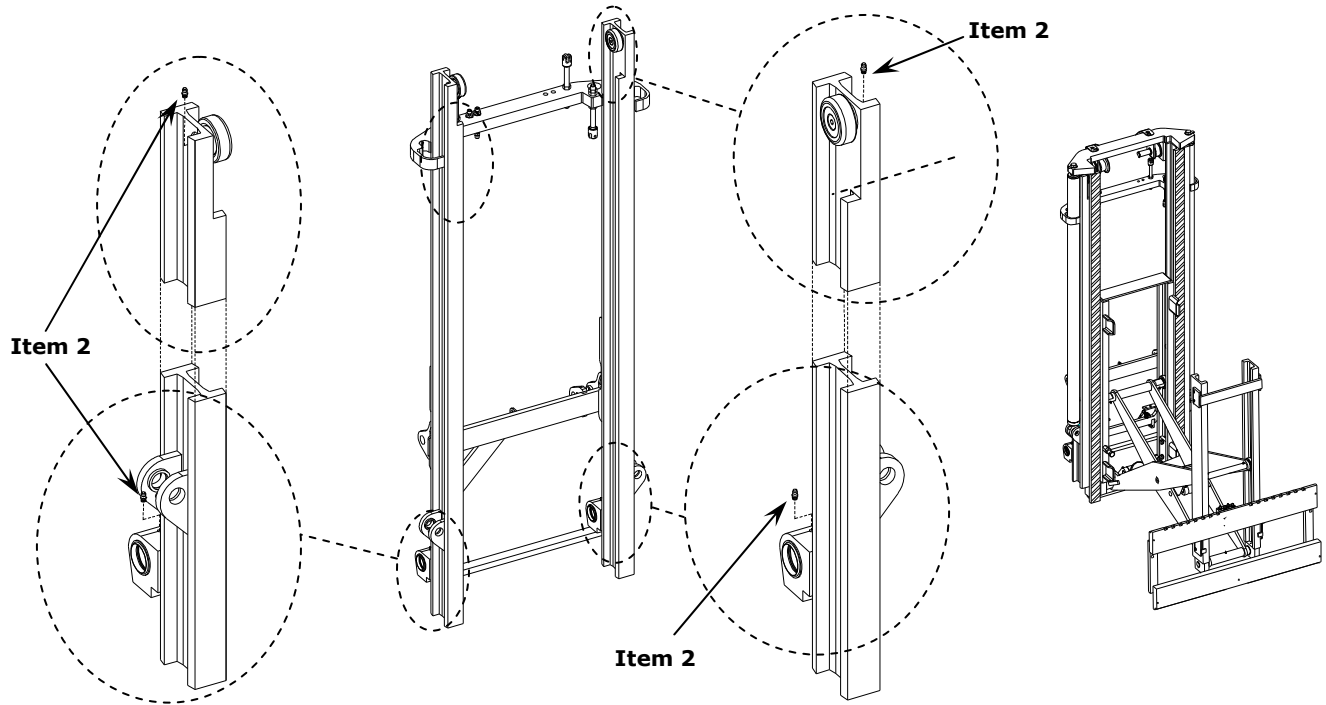

## B5. MAINTENANCE – PANTOGRAPH & TELESCOPIC FORKS

### GREASE POINTS ON MAST INNER SECTION

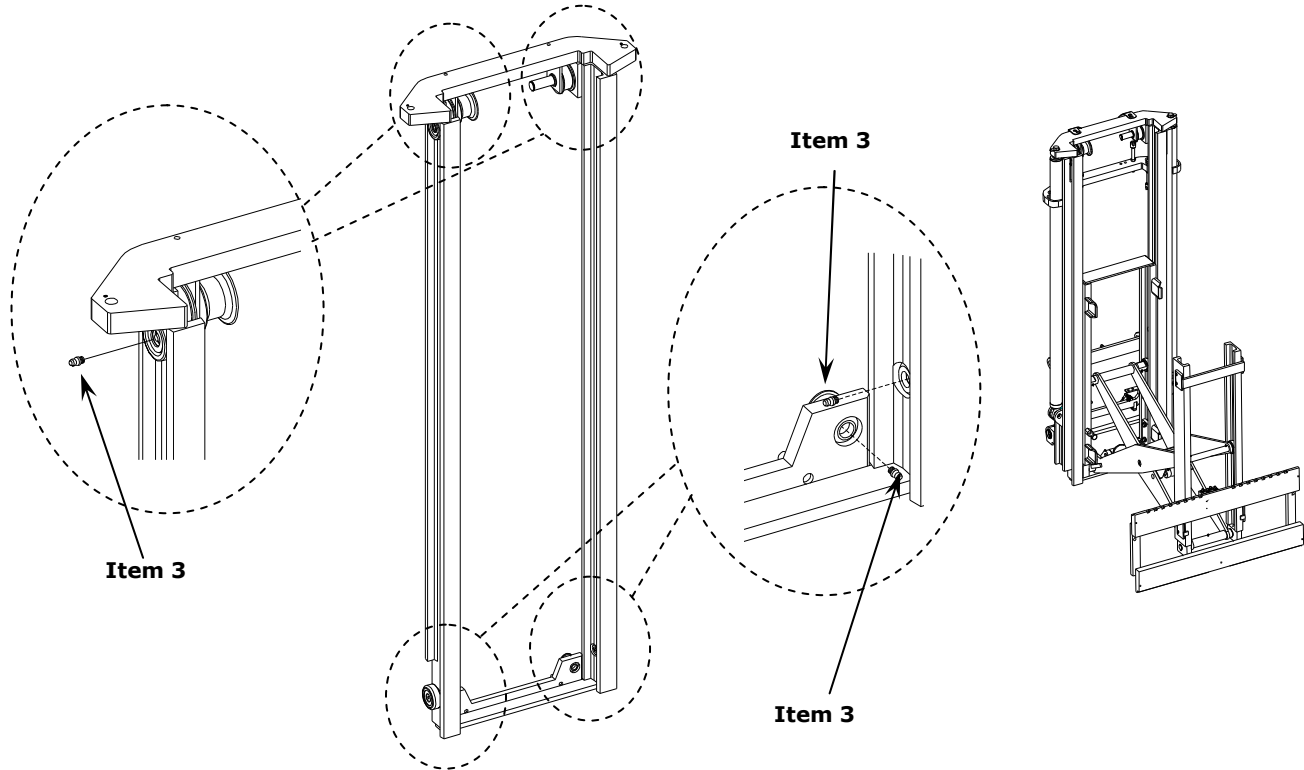

## B5. MAINTENANCE – PANTOGRAPH & TELESCOPIC FORKS

### GREASE POINTS ON PANTOGRAPH MAST SECTION

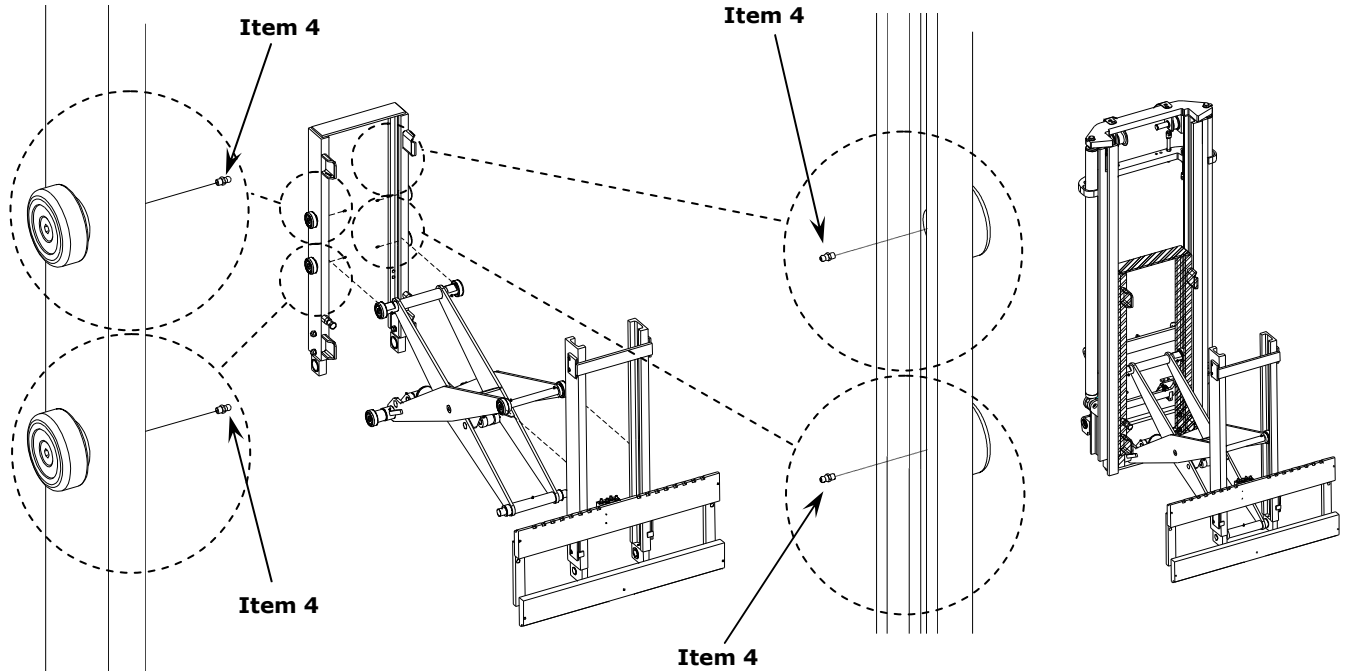

## B5. MAINTENANCE – PANTOGRAPH & TELESCOPIC FORKS

### GREASE POINTS ON PANTOGRAPH ARM

Location of pantograph arm on machine

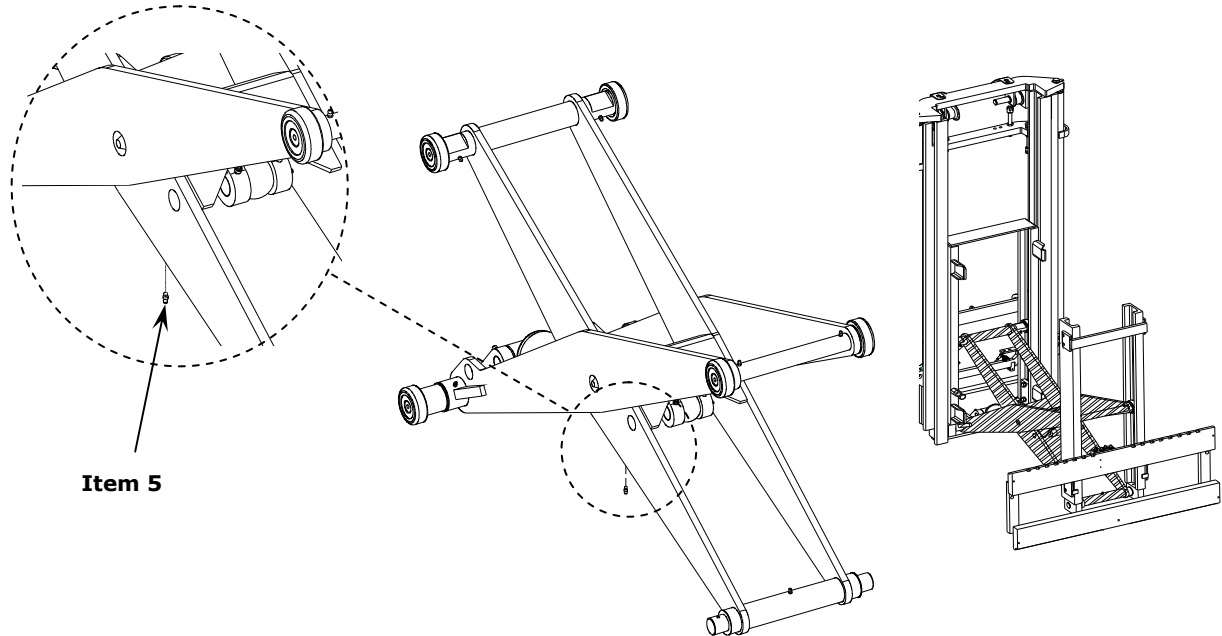

## B5. MAINTENANCE – PANTOGRAPH & TELESCOPIC FORKS

### GREASE POINTS ON PANTOGRAPH ARM

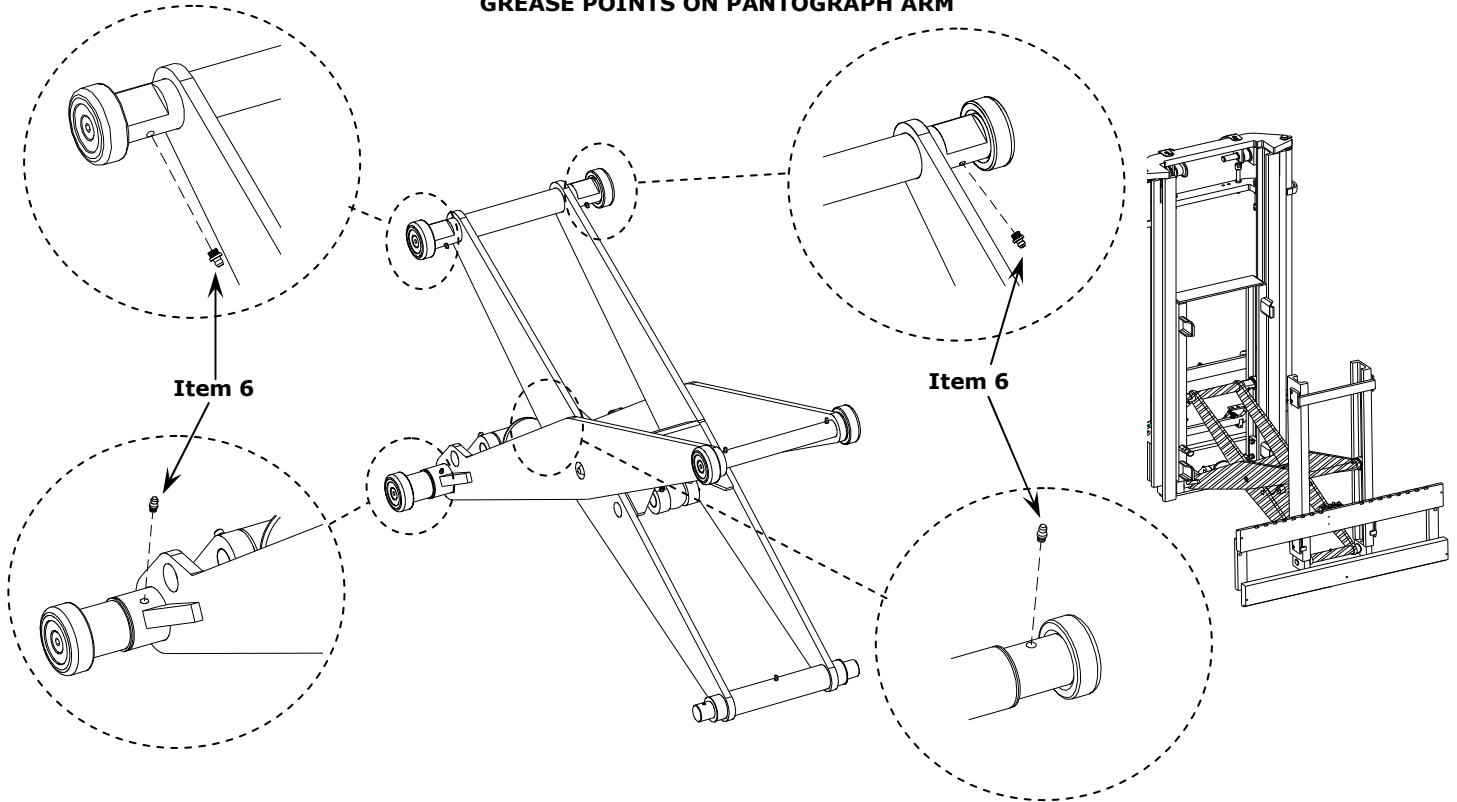



## B5. MAINTENANCE – PANTOGRAPH & TELESCOPIC FORKS

### GREASE POINTS ON PANTOGRAPH ARM

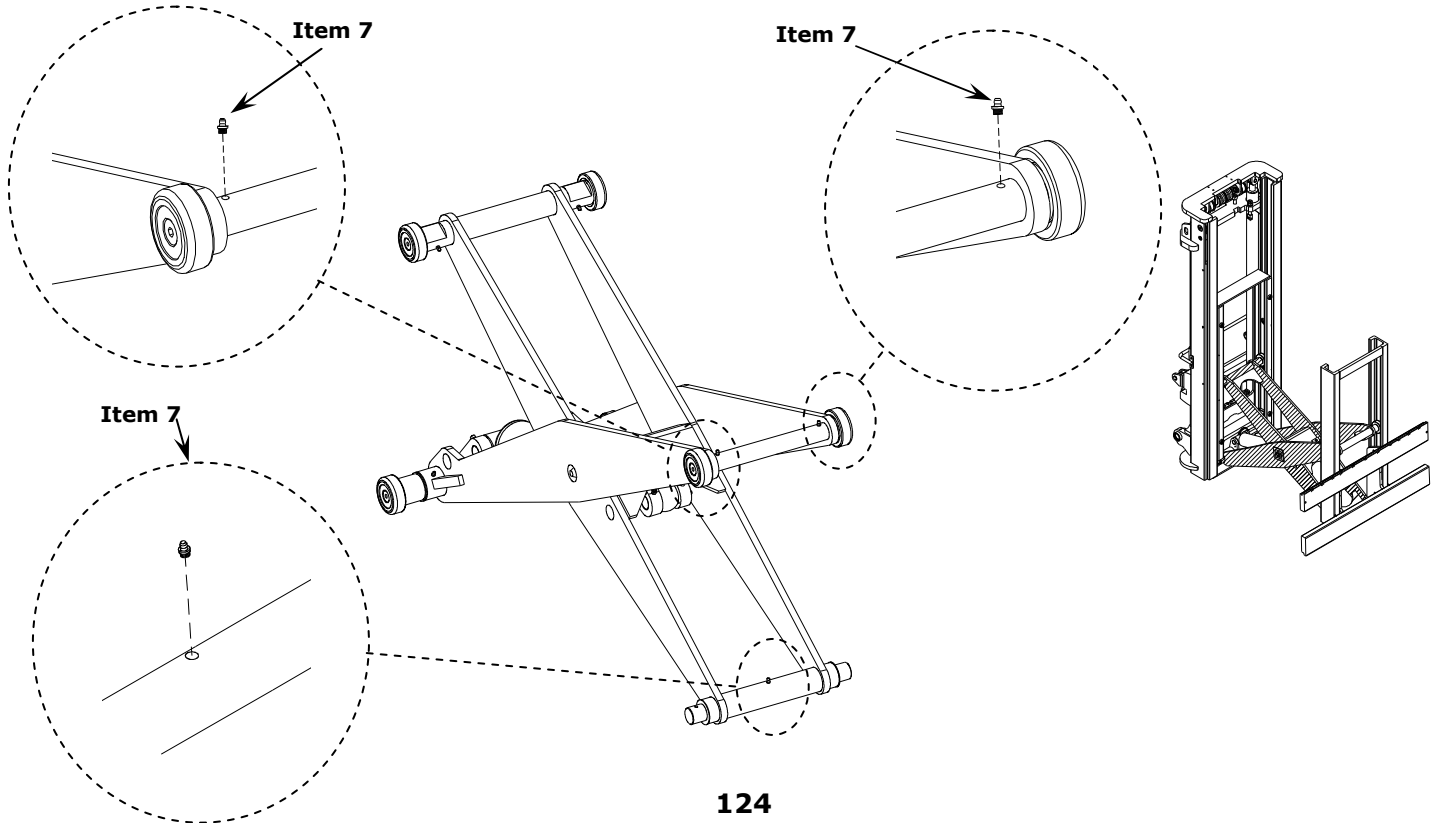

## B5. MAINTENANCE – PANTOGRAPH & TELESCOPIC FORKS

### GREASE POINTS ON PANTOGRAPH EXTENSION CYLINDER

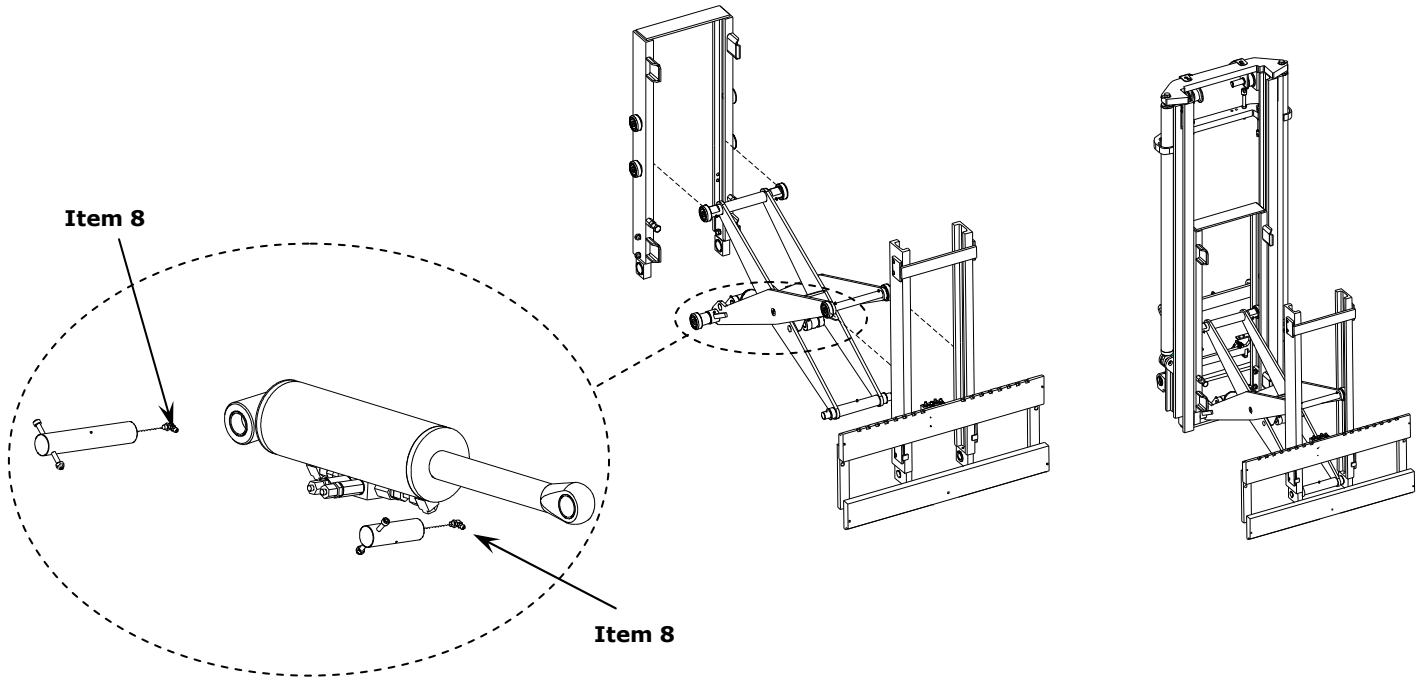

## B5. MAINTENANCE – PANTOGRAPH & TELESCOPIC FORKS

### GREASE POINTS ON TELESCOPIC FORKS

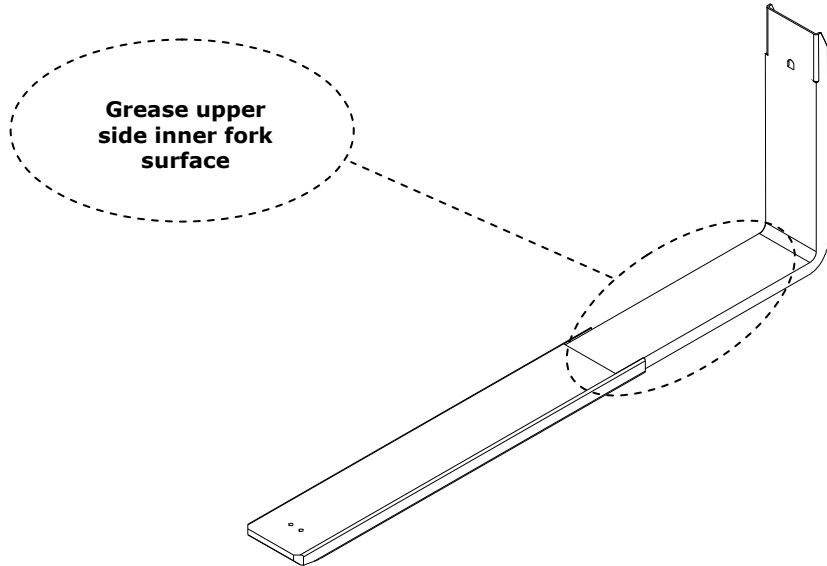



# Operator Manual

## Moffett Truck Mounted Forklift 4-Way Machines

**Note:**

This section of the manual describes additional operating instructions for the Moffett Truck-Mounted Forklift 4-Way unit and should only be used as a supplement to the operator manual.

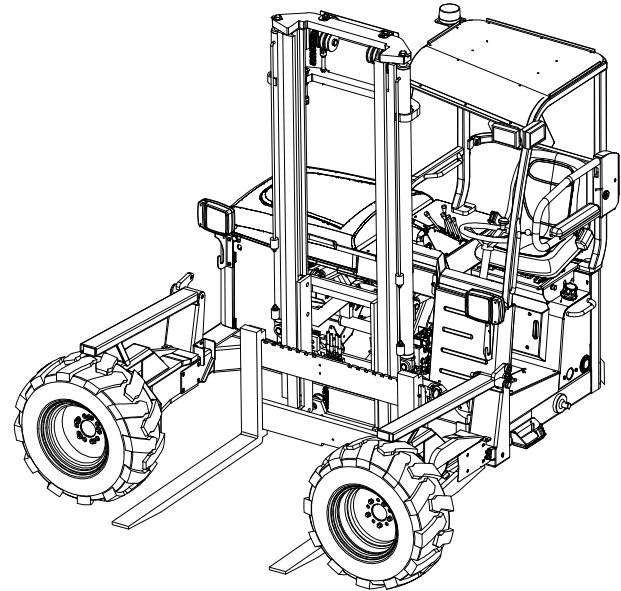

Delivering **Confidence**

## C. INTRODUCTION – 4-WAY STEERING

### Overview of 4-Way Steering System

In addition to conventional direction travel Forward and Backward (**2-Way Mode** - front wheels locked straight ahead and rear wheel steering) this machine is also fitted with two front steering cylinders.

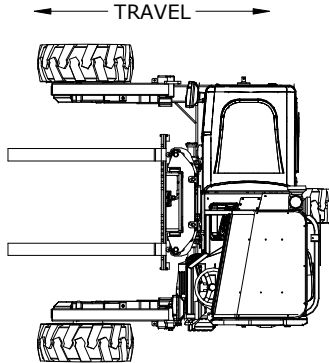

Forward Mode Of Operation

### 2-WAY MODE

These front steering cylinders enable the machine to travel sideways (**4-Way Mode** - rear wheel locked to 90° front wheels steering). When the machine is in 4-Way Mode the front steering cylinders are connected in Series. The larger RH cylinder full bore side feeds into the LH cylinder rod side when steering to straight ahead and vice versa when turning to 90°.

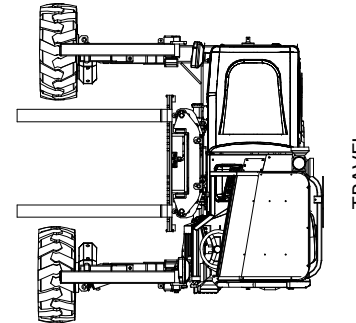

Lateral Mode Of Operation

### 4-WAY MODE

## C1. SAFETY CHECKLIST – 4-WAY STEERING

### Safety Checklist



#### **WARNING:**

##### **Using This Manual**

This section of the manual describes additional operating instructions for the Moffett Truck-Mounted Forklift 4-Way unit and should only be used as a supplement to the operator manual.



#### **WARNING:**

##### **Travelling.**

NEVER Travel in 4-Way mode without a load.  
NEVER Change modes when machine is moving.  
Without a load, travel in normal mode with the reach device retracted.



#### **WARNING:**

##### **Using 4-Way.**

Change into and out of 4-Way mode on a firm level surface. Never change modes while the machine is moving. Always apply Park Brake before changing steering modes.



#### **WARNING:**

##### **Travelling On Inclines.**

When on an incline, the combined centre of gravity moves downhill. In 4-Way mode the combined centre of gravity will be closer to the edge of the stability triangle and the stability is reduced.

Reference Page 139. Operating on Inclines and Unusual Ground Surfaces.



#### **CAUTION:**

##### **Operating the Machine.**

Do not extend the reach device when travelling in 4-Way mode.

Do not select the 4-Way mode when the reach device is extended.

Always ensure forks are central and either fully down or above the frame prior to changing into 4-Way.

## C2. INTRODUCTION – 4-WAY STEERING

### Safety Decals

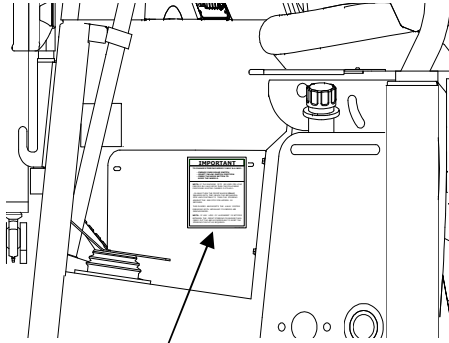

Location of 517.100.0072

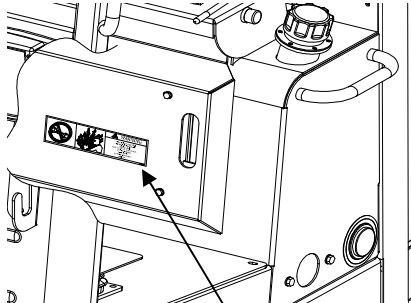

Location of 517.062.0001

Part No. 517.100.0072

### IMPORTANT

TO CHANGE STEERING MODES 2-WAY & 4-WAY:

- ENGAGE PARK BRAKE SWITCH
- SELECT 2W-4W SWITCH POSITION
- PRESS THE MODE BUTTON TO MOVE THE WHEELS.

**NOTE:** IF THE MACHINE IS TO BE USED FOR LONG PERIODS IN 2-WAY MODE THEN THE FOLLOWING PROCEDURE MUST BE CARRIED OUT DAILY:

- IN 4WAY TURN THE FRONT WHEELS **FULLY** INWARDS UNTIL THEY REACH THE MECHANICAL STOP AND CONTINUE TO TURN THE STEERING AGAINST THE END STOP FOR APPROX. 20 SECONDS.

THIS PURGES AND RESETS THE 4-WAY SYSTEM ENSURING BOTH HYDRAULIC CYLINDERS ARE SYNCHRONIZED.

**NOTE:** IF ANY LOSS OF ALIGNMENT IS NOTICED BETWEEN THE FRONT STEERING CYLINDERS THEN CARRY OUT THE ABOVE PROCEDURE TO RESET THE STEERING CIRCUIT AS REQUIRED.

517.100.0072

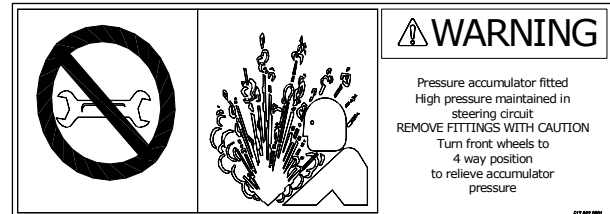

Accumulator decal 517.062.0001

## C2. INTRODUCTION – 4-WAY STEERING

### Safety Decals (continued)

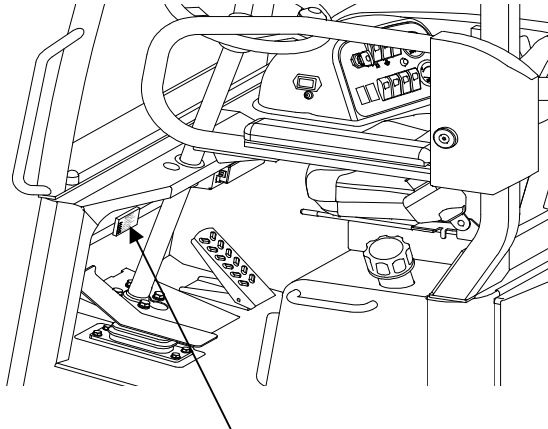

Location of 517.106.0000

Part No. 517.106.0000



- — 4 WAY SWITCH
- — CARRIAGE LIMIT SWITCH
- — REAR PRESSURE SWITCH
- — MAST PROX SWITCH
- — FRONT PRESSURE SWITCH
- — BACKUP POWER

517.106.0000

**Note:** The status of the 4-Way system as well as simple fault finding can be seen by the colour of the LED's on the control module.



## C2. INTRODUCTION – 4-WAY STEERING

### Instruments and Controls

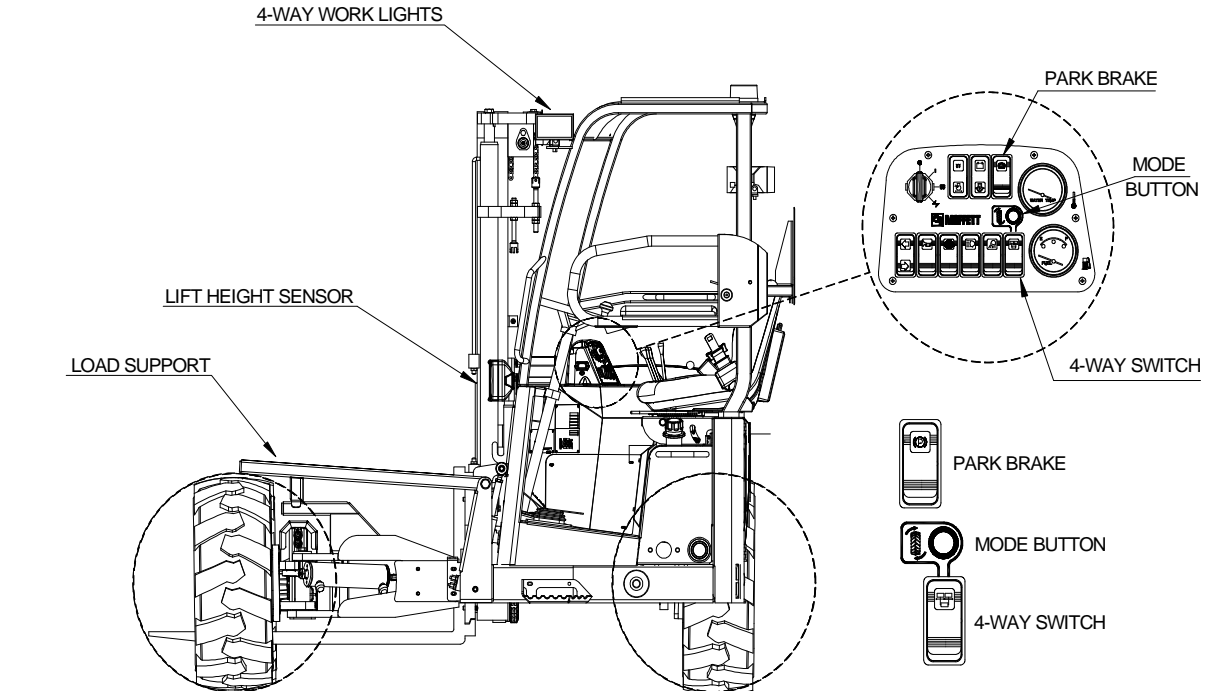



### C3. CENTRE OF GRAVITY – 4-WAY STEERING

**Note:** The width of the Stability Triangle is reduced when the lateral (4-Way) mode is engaged. This creates a narrower stability pyramid compared to when the Moffett is in Normal (2-Way) mode, causing the forklift to become less stable laterally as the load is elevated. This is why the lift height is restricted to 2m to maintain an optimum level of lateral stability (see below).

#### LIFT HEIGHT RESTRICTION

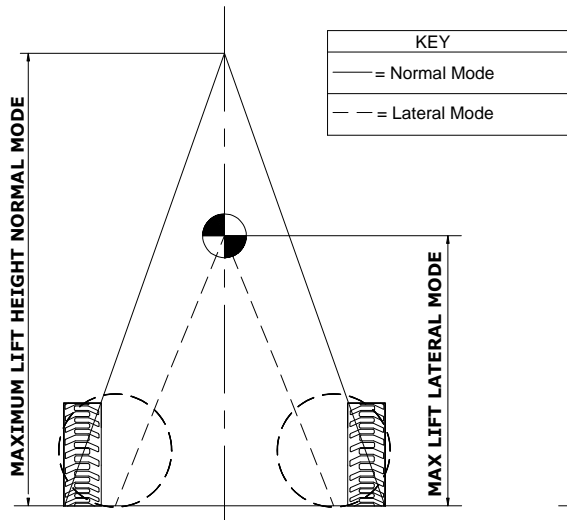

#### **WARNING**

**NEVER TRAVEL IN THE LATERAL MODE WITH AN ELEVATED LOAD.**

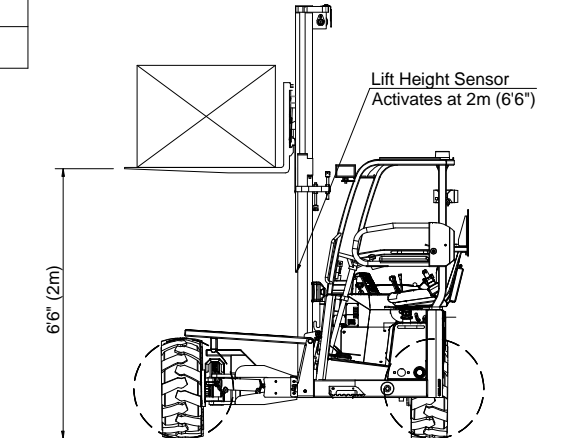

## C4. OPERATING PROCEDURES – 4-WAY STEERING

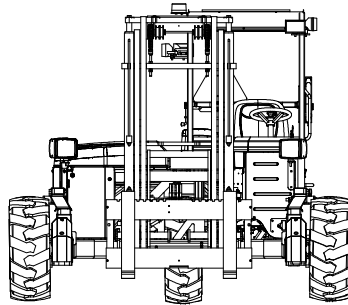

**NORMAL MODE 2-WAY**

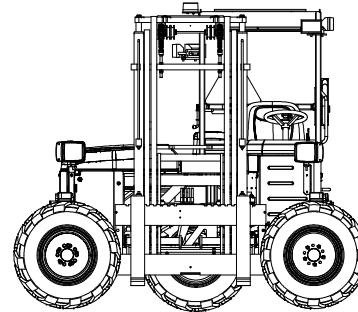

**4-WAY MODE**

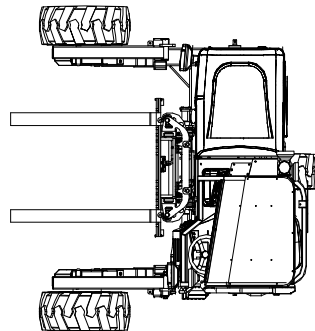

Forward Mode Of Operation

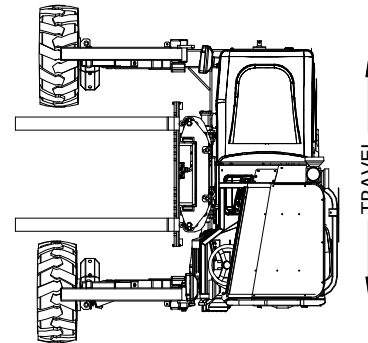

Lateral Mode Of Operation

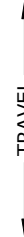

## C4. OPERATING PROCEDURE – 4-WAY STEERING

### Instruments And Controls

#### Changing Steering Modes

All machines can be changed from 2-Way to 4-Way steering mode by following the sequence below. The machine can be changed semi automatically using the Mode button or manually using the steering wheel.

#### A. Mode Button Operation

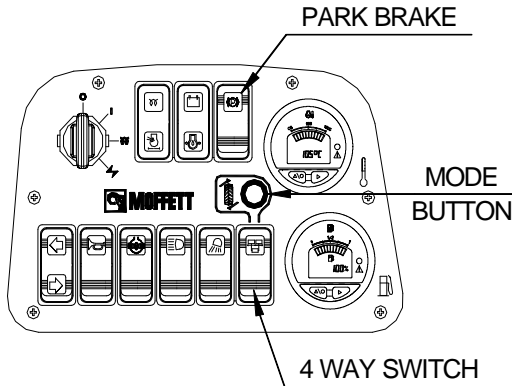

**Note:** The Mode button will only work if the machine is stationary and the electric park brake is applied as the park brake interlocks the function of the Mode button.

#### A1. Changing from 2-Way to 4-Way

1. Ensure machine is stationary on level ground
2. Apply the electric PARK BRAKE.
3. Change 4-Way switch to 4-Way position.
4. Push red MODE button until rear wheel moves to 90° position then release.
5. System will automatically change oil to front wheels.
6. Continue to press red MODE button until front wheels are at 90° then release.
7. Release park brake ready to drive.
8. Machine is now in 4-Way Mode.

#### A2. Changing from 4-Way to 2-Way

1. Ensure machine is stationary on level ground
2. Apply the electric PARK BRAKE.
3. Change mode switch to 2-Way position.
4. Push red MODE button until front wheels come to straight ahead position then release.
5. System will automatically change oil to rear wheel.
6. Continue to push red MODE button until rear wheel is in the straight ahead position then release.
7. Release the park brake ready to drive.
8. The machine is now in 2-Way Mode.

## C4. OPERATING PROCEDURE – 4-WAY STEERING

### Instruments And Controls (continued)

#### Changing Steering Modes (continued)

#### B. Manual Operation

##### B1. Changing from 2-Way to 4-Way

1. Ensure machine is stationary on level ground.
2. Apply electric PARK BRAKE.
3. Steer rear wheel to 90° position using the steering wheel.
4. Change the 4-Way switch to 4-Way position.
5. Steer front wheels to 90° using the steering wheel.
6. Release park brake ready to drive.
7. Machine is now in 4-Way Mode.

##### B2. Changing from 4-Way to 2-Way

1. Ensure machine is stationary on level ground.
2. Apply electric PARK BRAKE.
3. Steer front wheels to straight ahead using the steering wheel.
4. Change the 4-Way switch to 2-Way position.
5. Steer rear wheel to straight ahead position using the steering wheel.
6. Release the park brake ready to drive.
7. The machine is now in 2-Way Mode.

**Note:** Always change steering modes using minimum engine revs, this ensures the pressures raised in the rear steering ram are kept to a minimum.

If changing steering modes in extremely deep mud or severe ground conditions then higher than normal steering pressures could be generated in the steering lines. These higher pressures may trigger the pressure switches in the automatic system before the steering wheels have fully reached their stops. If this occurs then change back to the previous steering mode and manually steer the wheels fully to the stops before switching to desired steering mode. If the rear arm will not steer manually then the ground conditions are too severe to change steering modes the operator needs to find improved ground conditions before changing steering modes.

Also if the machine is used in very cold conditions always ensure that the machine is warmed up fully before attempting to change steering modes as the cold oil will also create higher than normal steering pressures.

## C4. OPERATING PROCEDURE – 4-WAY STEERING

### Instruments And Controls MMS

#### A. Fully Automatic Operation

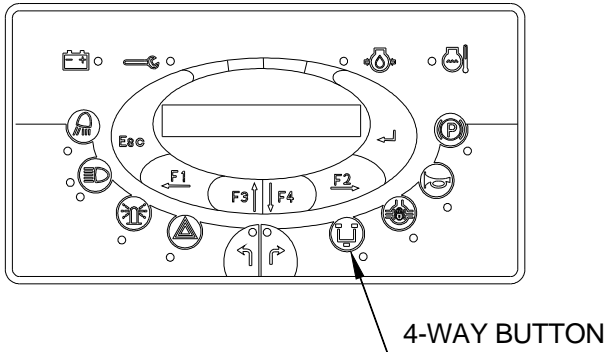

#### A1. Changing from 2-Way to 4-Way

1. Ensure machine is stationary on level ground.
2. Apply the electric PARK BRAKE.
3. Push red 4-Way button until rear wheel moves to 90° and continue to press the button.
4. System will automatically change oil to front wheels.
5. Continue to press red 4-Way button until front wheels are at 90° then release.
6. Release PARK BRAKE ready to drive.
7. Machine is now in 4-Way Mode.

#### A2. Changing from 4-Way to 2-Way

1. Ensure machine is stationary on level ground.
2. Apply the electric PARK BRAKE.
3. Push red 4-Way button until front wheels comes to straight ahead position and continue to press the button.
4. System will automatically change oil to rear wheel.
5. Continue to press red 4-Way button until rear wheel comes to straight ahead position then release.
6. Release PARK BRAKE ready to drive.
7. Machine is now in 2-Way Mode.

## **C4. OPERATING PROCEDURE – 4-WAY STEERING**

### **B. Manual Operation**

#### **B1. Changing from 2-Way to 4-Way**

1. Ensure machine is stationary on level ground.
2. Apply the electric PARK BRAKE.
3. Steer rear wheel to 90° position using the steering wheel.
4. Push red 4-Way button.
5. Steer front wheels to 90° position using the steering wheel.
6. Release PARK BRAKE ready to drive.
7. Machine is now in 4-Way Mode.

#### **B2. Changing from 4-Way to 2-Way**

1. Ensure machine is stationary on level ground.
2. Apply the electric PARK BRAKE.
3. Steer front wheels to straight ahead position using the steering wheel.
4. Push red 4-Way button.
5. Steer rear wheel to straight ahead position using the steering wheel.
6. Release PARK BRAKE ready to drive.
7. Machine is now in 2-Way Mode.



## C4. OPERATING PROCEDURE – 4-WAY STEERING

### Instruments And Controls (continued)

The relays which control the functions of the 4-Way steering system are also linked to 6 LED's which can be seen on the control module located under the front lip of the pedal enclosure.

The function and colour of these LED's is outlined below and they can be used to check the status of the 4-Way system as well as simple fault finding.

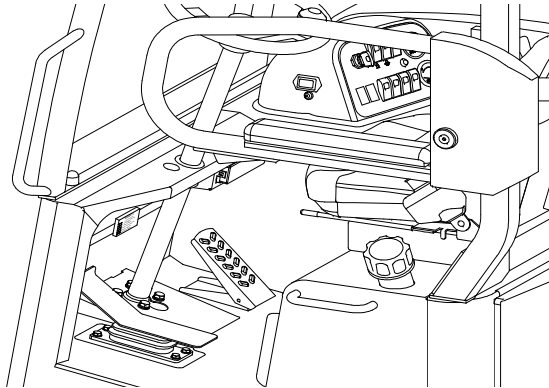

### Control Module LED Decal

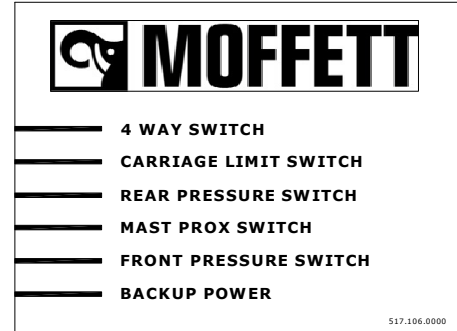

### LED Function and Colour

- A – Green if 4-Way switch is in the 4-Way mode.
- B – Green if Carriage is back ready for mode change.
- C – Green if Rear Pressure switch is activated.
- D – Green if Mast height is below limit.
- E – Green if Front Pressure switch is activated.
- F – Green if Power is ON to Control Module.

If any of the LED's do not light up green as outlined above then refer to Section C7. Special Procedures.

## C4. OPERATING PROCEDURES – 4-WAY STEERING

### Lifting A Wide Load

- Approach the trailer in 2-Way mode.
- Make sure the load to be lifted is stable and secure.
- Check the weight and load centre of the load to be lifted. If the weight is not marked or shown on the load, check the weight with your supervisor or have it weighed. If it is too heavy, split the load and restack it.
- Centre the forks as wide as possible to suit the load.
- Extend the reach device fully.
- Fold down the load supports.
- Align the forks with the centre of the load, approach it squarely and drive into the load until the forks are fully engaged.
- Check that the ground surface is strong enough to support the stabilisers.
- Lower the stabilisers fully.
- Raise the load to clear the truck / trailer bed.
- Tilt the mast rearward to secure the load.
- Sideshift the mast to the centre position.
- Retract the reach device fully to bring the load above the front wheels.
- Raise the stabilisers fully
- Back away slowly to ensure the load clears the truck / trailer bed.
- Apply the parking brake.
- Lower the load onto the load rests, keeping the forks in contact with the bottom of the load.
- Ensure the machine is on a firm level surface.
- Change to 4-Way mode.
- Disengage the parking brake. The machine can now be driven in 4-Way mode.
- Depress the pedal (toe) forward to move the machine to the right, depress the pedal (heel) back to move the machine to the left.

## C4. OPERATING PROCEDURES –PLACING A WIDE LOAD

### Placing A Wide Load

- When travelling in 4-Way mode with wide load that needs to be placed.
- First ensure the placement area is a firm level surface.
- Check that the area is clear of debris.
- Approach the final position squarely.
- Apply the parking brake.
- Raise the load until it clears the load rests.
- Change to 2-Way Mode.
- Check that the ground surface is strong enough to support the stabilisers.
- Lower the stabilisers fully.
- Extend the reach device fully to clear the frame, wheels and load rests.
- Lower the forks to the ground to deposit the load
- Tilt the mast forward slightly to deposit the load.
- Raise the stabilisers fully.
- Disengage the parking brake.

- Check that the rear wheel is in the straight ahead position.
- Back up carefully.
- Drive slowly facing the direction of travel keeping the reach device fully retracted.



#### **WARNING:**

**No Load.** Never travel in 4-Way mode without a load on the forks. Always change to Normal 2-Way mode when travelling with No Load and ensure the reach device is fully retracted.

## C4. OPERATING PROCEDURE – 4-WAY STEERING

### **Operating On Inclines And Unusual Ground Surfaces.**

- Do not travel in 4-Way mode without a load.
  - Do not travel across an incline in 4-Way mode.
  - Always approach an incline to the left and travel up and down the incline. Drive up an incline to the left. Drive down an incline to the right.
  - Keep the operators compartment facing uphill.
  - Do not turn on an incline
  - Never stop or start suddenly.
  - Operate all controls smoothly.
  - Watch out for potholes or other obstacles that could affect the stability of the machine.
  - Drive slowly over rough terrain.
  - Where necessary, engage the diff-lock and travel slowly for additional traction.
- Always take great care when transporting wide loads on any incline. Carry the load on the load rests keeping the forks in contact with the bottom of the load.
  - Make allowances for the reduction in both stability and lift capacity when operating on inclines.
  - Remember that a machine in 4-Way mode is less stable than in normal mode.
  - Do not attempt to drive up or down an incline in 4-Way mode just because you have driven up or reversed down in normal mode.
  - Only use 4-Way mode when it is not otherwise possible to carry a wide load.

## C4. OPERATING PROCEDURES - OPERATING ON INCLINES



### **WARNING:**

#### **On 4-Way Models:**

- Change into and out of 4-Way mode on a firm level surface only.
- Never travel in 4-Way mode without a load.



### **WARNING:**

When on an incline, the combined centre of gravity moves downhill. In 4-Way mode the combined centre of gravity will be closer to the edge of the stability triangle and stability is reduced.

**(Maximum Gradability = 30%)  
In Normal Mode**

DRIVE UP TO THE LEFT  
→

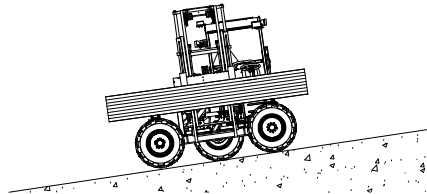

DRIVE DOWN TO THE RIGHT  
→

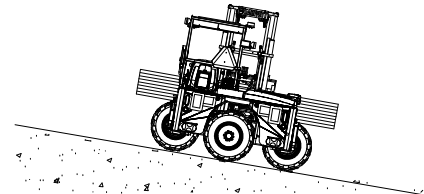

C. 4-Way Mode - Forks Fully Retracted - With Load

**(Maximum Gradability = 15%)  
In 4-Way Mode**

## C4. OPERATING PROCEDURES - OPERATING ON INCLINES

### Operating on Inclines

**Note:** When travelling on an incline the combined centre of gravity moves downhill. In 4-Way mode the combined centre of gravity will be much closer to the edge of the stability triangle as the machine is travelling sideways. This means the stability of the machine will be reduced.

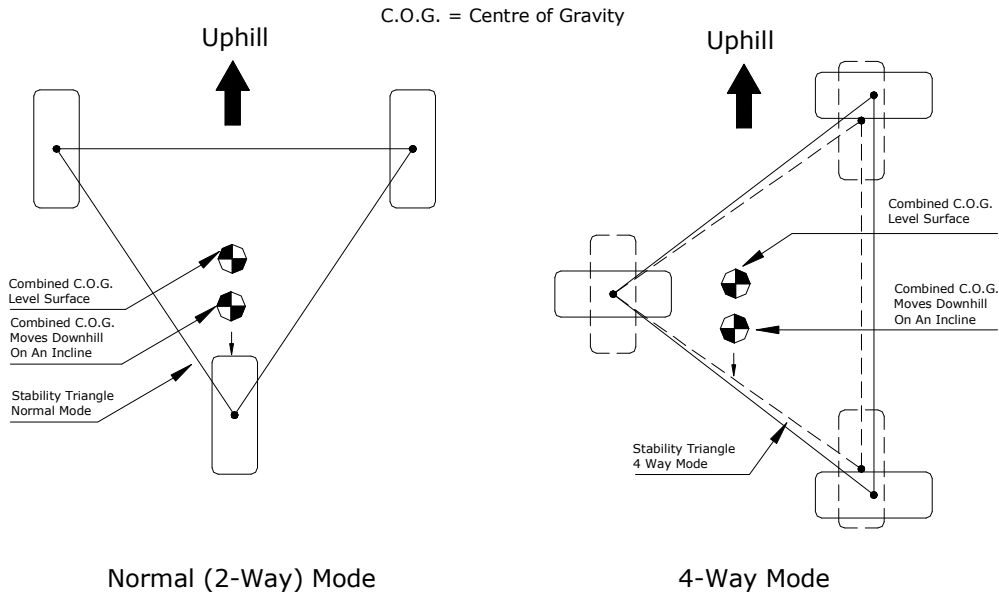

## C4. OPERATING INSTRUCTIONS – 4-WAY STEERING

### Load Supports

The 4-Way machine is fitted with Load Supports, these are used in conjunction with wide loads to minimize load deflection and increase load stability.



### WARNING:

Never travel in the lateral (4-Way) mode with an elevated load. Always keep the load as low as possible.

Never travel in Lateral (4-Way) mode with no load on the forklift.

**Note:** Always fold up the Load Supports before transporting the machine.

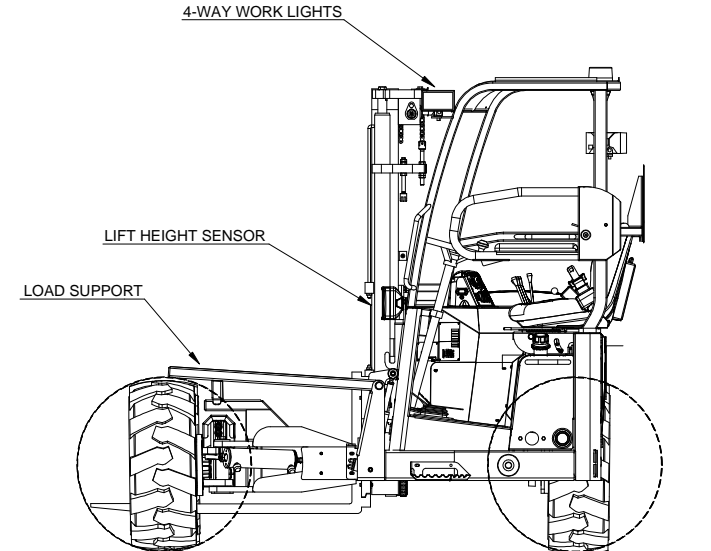

## C4. OPERATING THE 4-WAY MACHINE – POINTS TO REMEMBER

### Points To Remember:

Ensure you are on a firm and level surface before engaging the lateral (4-Way) mode.

Only use lateral (4-Way) mode where it is not possible to otherwise carry a wide load.

Never travel in 4-Way mode without a load.

Always carry the load on the forks AND the load supports.

Never start or stop suddenly. Operate all controls smoothly.

Watch out for potholes or other obstacles which could affect the stability of the forklift.

Drive slowly over rough terrain.

Where necessary, engage the difflock and travel slowly for additional traction.

Never travel in 4-Way mode with an elevated load, always keep the load as low as possible.

Never turn on an incline.

Always keep the operator's compartment facing uphill when travelling on inclines.

Do not attempt to drive up or down an incline in 4-Way mode just because you have driven up or reversed down previously in normal mode.

Always return to the normal mode (2-Way) before placing a load.

### Before Selecting 4-Way (Lateral) Mode

1. Ensure machine is stationary.
2. Ensure reach device is fully retracted.
3. Ensure the stabilisers are fully raised.
4. Ensure the load is above the height of the wheels.

### While In 4-Way (Lateral) Mode

1. Do not extend reach device.
2. Do not use stabilising legs.
3. Transport the load as low as possible above the wheels.
4. Operate the forward / reverse pedal as smoothly as possible.
5. **The light on the 4-Way switch signifies that you are in 4-Way mode, as well as the 4-Way work lights and beeper being activated.**



## C5. MOUNTING PROCEDURE – 4-WAY STEERING

Mount as per standard machine (See section 5)

**Note: During the truck mounting/dismounting sequence never engage 4-Way mode as serious damage will occur to the mounting kit and the machine.**

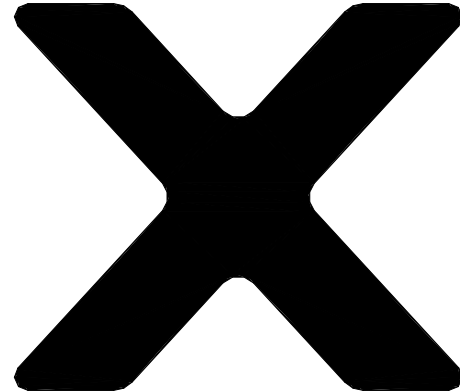
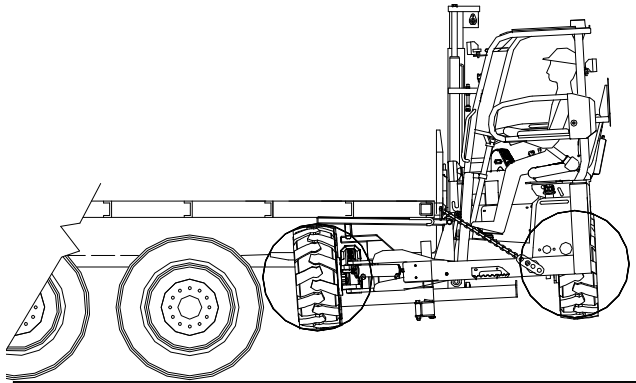

## C6. MAINTENANCE – GREASE POINTS

### FRONT STEERING CYLINDERS

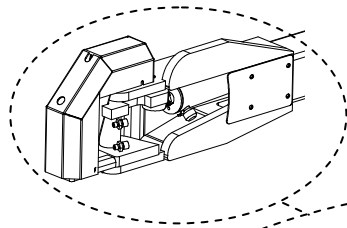

Location of front steering cylinders on machine

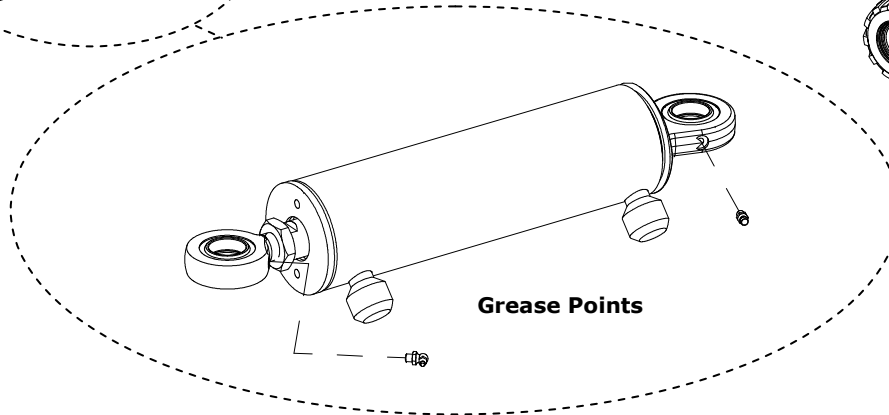
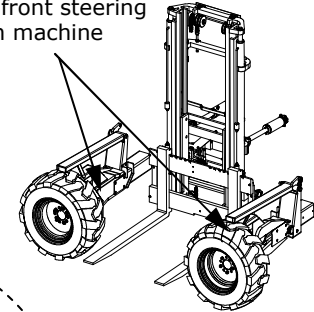

**Note.** Refer to the standard operator manual for the standard grease points on the machine.

## C6. MAINTENANCE – GREASE POINTS

### FRONT STEERING SWIVELS

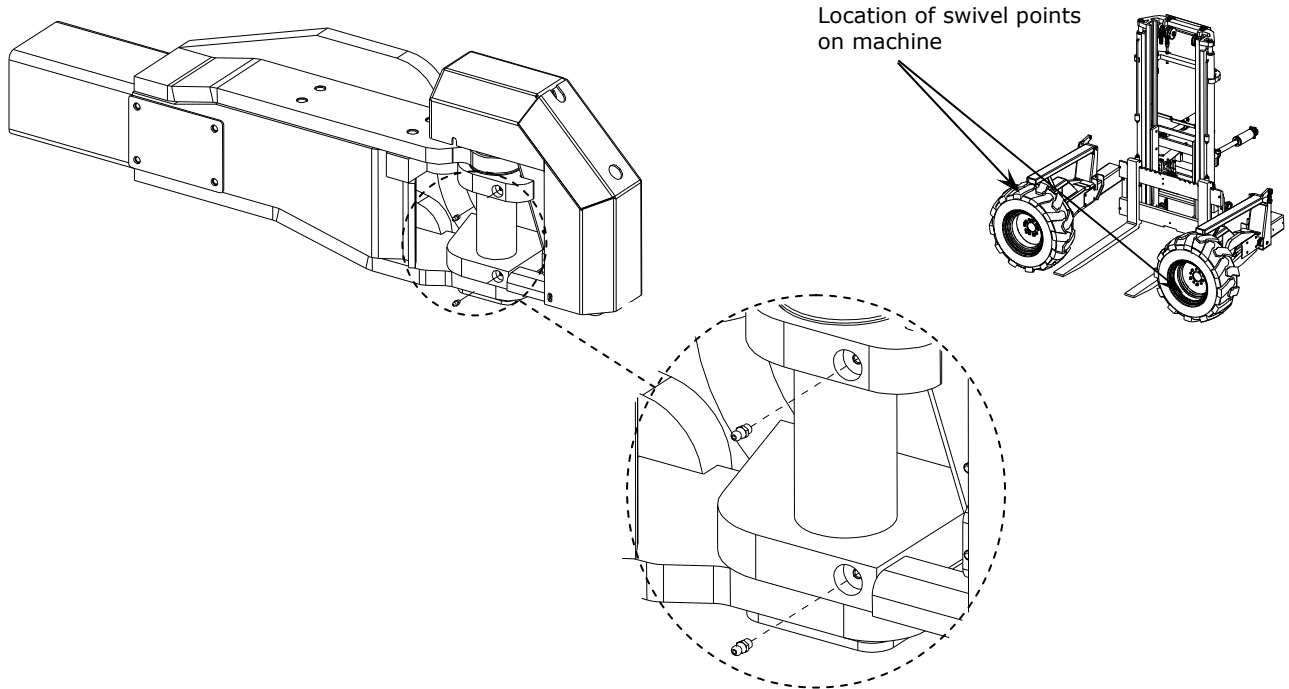

## C6. MAINTENANCE – GREASE POINTS

### STABILISER GREASE POINTS

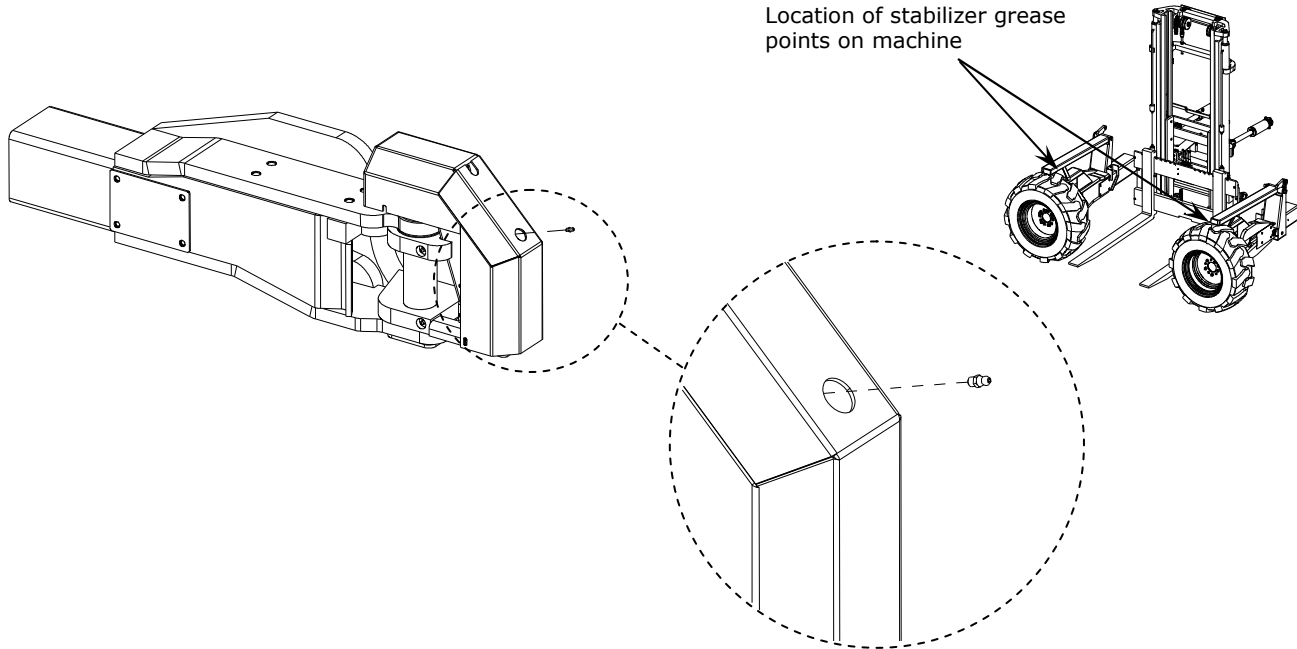

## C6. MAINTENANCE – GREASE POINTS

### LOAD RESTS GREASE POINTS

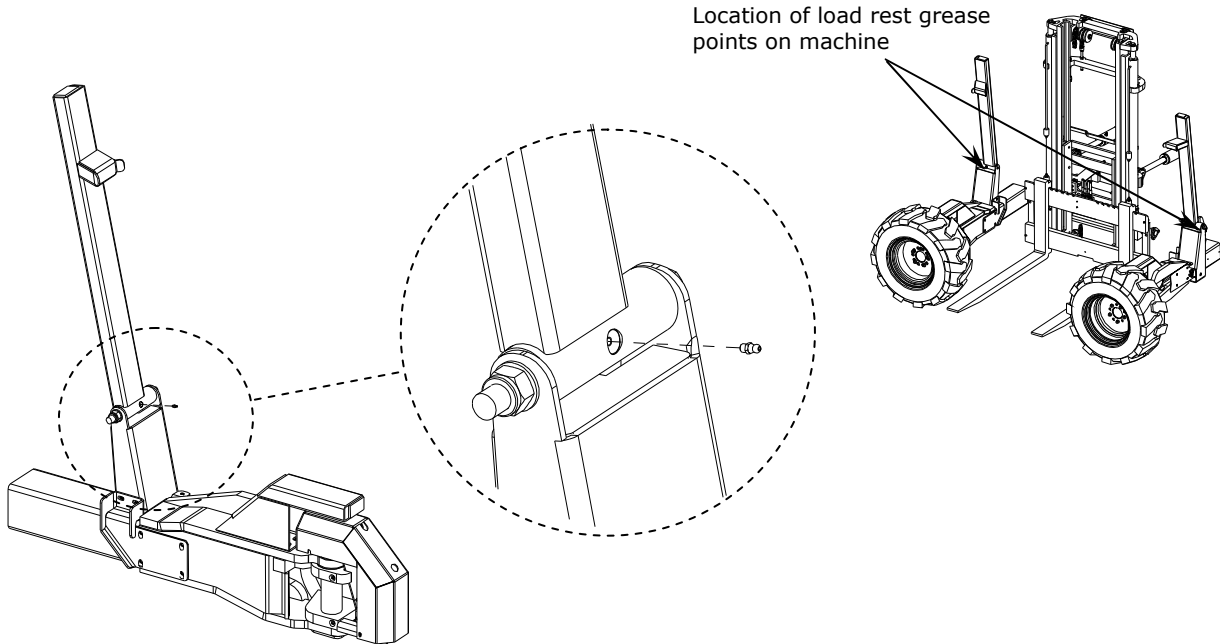

## C6. MAINTENANCE – GREASE POINTS

### LOAD REST CYLINDER GREASE POINTS

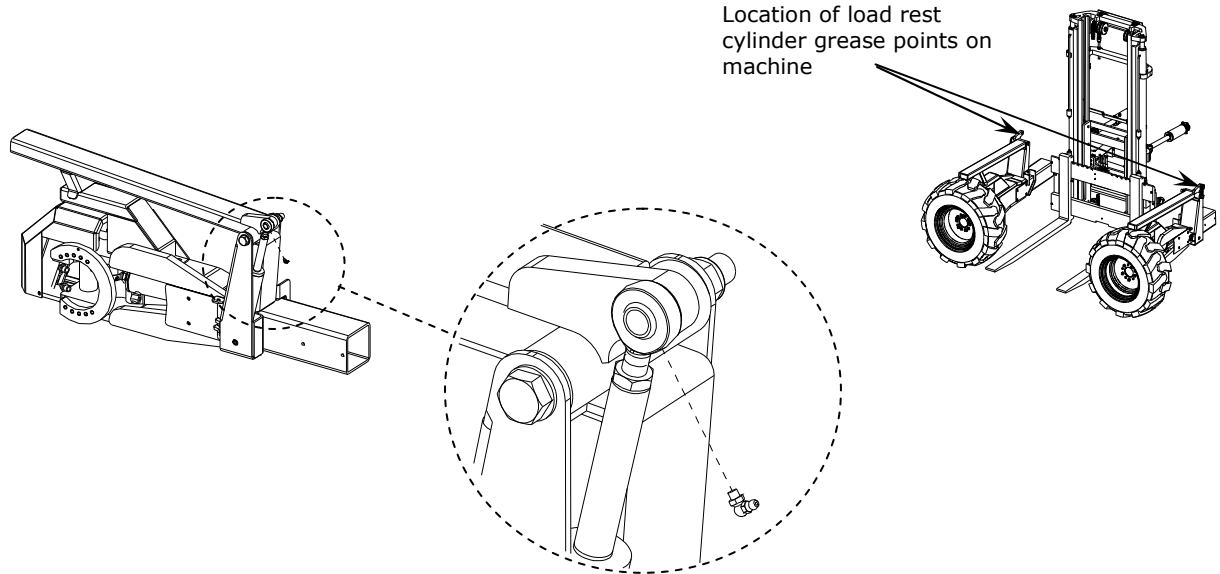

## C6. MAINTENANCE

### Daily Maintenance Inspection

In addition to the daily maintenance inspection that is listed in the standard operator manual, some additional daily checks should be carried out on 4-Way machine.

Before you begin your work day take time to check your machine and make certain that the front steer system is in good operational condition.

Please carry out the following procedure:

On the series steer circuit daily turn the wheels fully inwards to the 4-Way position until they reach the mechanical stop. Continue to turn the steering against the end stop for approximately 20 seconds.

This purges and resets the 4-Way system ensuring both hydraulic cylinders are synchronised.

**Note:** If the machine is to be used continuously then carry out the above sequence at one hour intervals of operation.

**Alternatively if any loss of alignment is noticed between the front two steering cylinders, carry out the above procedure to reset the steering circuit.**

## C7. SPECIAL PROCEDURES

### 4-Way Override Procedure

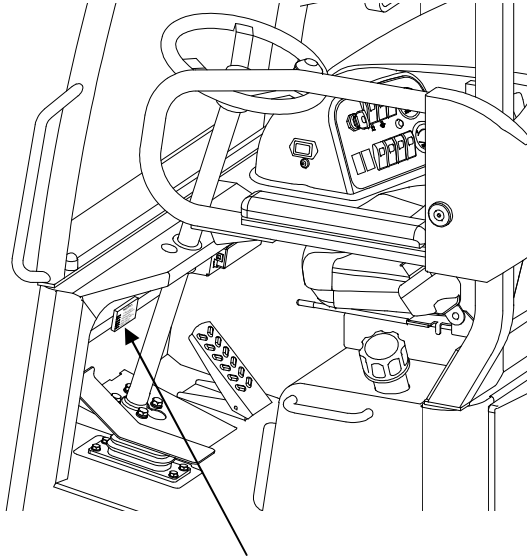

Location of 4-Way controller

In the event of a 4-Way system failure, a back up procedure is available on your machine to allow you to continue to operate the 4-way function manually until the machine can be serviced.

First check that all the 4-Way LED's on the Control Module are working as they should. If they are all OK then check the 4-Way fuse has not blown and if this is intact then the following procedure can be carried out.

1. Remove the 4-Way controller from the inside of the pedal enclosure as shown above.
2. Take the 4-Way override connector, this is tie wrapped to the wiring loom behind the steering column.
3. Plug the 4-Way override connector into the wiring loom at the same location the 4-Way controller has been removed from. The override connector is colour coded (black) to connect into branch eight of the wiring loom.
4. The 4-Way function can now be operated manually as described in the operation procedures.



**CALIFORNIA**

**Proposition 65 Warning**

**Diesel engine exhaust and some of its  
constituents are known to the State of California  
to cause cancer, birth defects and other  
reproductive harm**



---

Moffett Engineering Ltd.

Ardee Road, Dundalk, Co Louth Ireland.

Tel: +353 (0) 42 9359500 Fax: +353 (0) 42 9359590

Email: [moffett.forklift@hiab.com](mailto:moffett.forklift@hiab.com) Website: [www.hiab.com/forklifts](http://www.hiab.com/forklifts)

A Hiab Company

<https://www.forkliftpdfmanuals.com/>