

1. STRUCTURE

This service manual has been prepared as an aid to improve the quality of repairs by giving the serviceman an accurate understanding of the product and by showing him the correct way to perform repairs and make judgements. Make sure you understand the contents of this manual and use it to full effect at every opportunity.

This service manual mainly contains the necessary technical information for operations performed in a service workshop.

For ease of understanding, the manual is divided into the following sections.

SECTION 1 GENERAL

This section gives the general information of the machine and explains the safety hints for maintenance.

SECTION 2 REMOVAL & INSTALLATION OF UNIT

This section explains the procedures and techniques of removal and installation of each component.

SECTION 3 POWER TRAIN SYSTEM

This section explains the structure of the transmission as well as control valve and drive axle.

SECTION 4 BRAKE SYSTEM

This section explains the brake piping, each component and operation.

SECTION 5 STEERING SYSTEM

This section explains the structure of the steering unit, priority valve, trail axle as well as steering circuit and operation.

SECTION 6 HYDRAULIC SYSTEM

This section explains the structure of the gear pump, main control valve as well as work equipment circuit, each component and operation.

SECTION 7 ELECTRICAL SYSTEM

This section explains the electrical circuit and each component.

It serves not only to give an understanding electrical system, but also serves as reference material for troubleshooting.

SECTION 8 MAST

This section explains the structure of mast, carriage, backrest and forks.

The specifications contained in this service manual are subject to change at any time and without any advance notice. Contact your HYUNDAI distributor for the latest information.

2. HOW TO READ THE SERVICE MANUAL

Distribution and updating

Any additions, amendments or other changes will be sent to HYUNDAI distributors.

Get the most up-to-date information before you start any work.

Filing method

1. See the page number on the bottom of the page.

File the pages in correct order.

2. Following examples shows how to read the page number.

Example 1

2 - 3

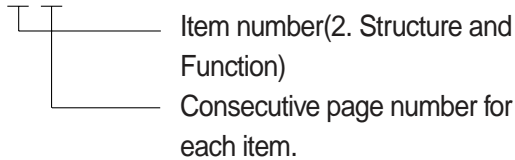

3. Additional pages : Additional pages are indicated by a hyphen(-) and number after the page number. File as in the example.

10 - 4

10 - 4 - 1

10 - 4 - 2

Added pages

10 - 5

Revised edition mark(①②③...)

When a manual is revised, an edition mark is recorded on the bottom outside corner of the pages.

Revisions

Revised pages are shown at the **list of revised pages** on the between the contents page and section 1 page.

Symbols

So that the shop manual can be of ample practical use, important places for safety and quality are marked with the following symbols.

Symbol	Item	Remarks
	Safety	Special safety precautions are necessary when performing the work.
		Extra special safety precautions are necessary when performing the work because it is under internal pressure.
	Caution	Special technical precautions or other precautions for preserving standards are necessary when performing the work.

3. CONVERSION TABLE

Method of using the Conversion Table

The Conversion Table in this section is provided to enable simple conversion of figures. For details of the method of using the Conversion Table, see the example given below.

Example

1. Method of using the Conversion Table to convert from millimeters to inches

Convert 55mm into inches.

- (1) Locate the number 50 in the vertical column at the left side, take this as (a), then draw a horizontal line from (a).
- (2) Locate the number 5 in the row across the top, take this as (b), then draw a perpendicular line down from (b).
- (3) Take the point where the two lines cross as (c). This point (c) gives the value when converting from millimeters to inches. Therefore, 55mm = 2.165 inches.

2. Convert 550mm into inches.

- (1) The number 550 does not appear in the table, so divide by 10 (Move the decimal point one place to the left) to convert it to 55mm.
- (2) Carry out the same procedure as above to convert 55mm to 2.165 inches.
- (3) The original value (550mm) was divided by 10, so multiply 2.165 inches by 10 (Move the decimal point one place to the right) to return to the original value.
This gives 550mm = 21.65 inches.

Millimeters to inches

(b)

1mm = 0.03937 in

	0	1	2	3	4	5	6	7	8	9
0		0.039	0.079	0.118	0.157	0.197	0.236	0.276	0.315	0.354
10	0.394	0.433	0.472	0.512	0.551	0.591	0.630	0.669	0.709	0.748
20	0.787	0.827	0.866	0.906	0.945	0.984	1.024	1.063	1.102	1.142
30	1.181	1.220	1.260	1.299	1.339	1.378	1.417	1.457	1.496	1.536
40	1.575	1.614	1.654	1.693	1.732	1.772	1.811	1.850	1.890	1.929
(a) 50	1.969	2.008	2.047	2.087	2.126	(c) 2.165	2.205	2.244	2.283	2.323
60	2.362	2.402	2.441	2.480	2.520	2.559	2.598	2.638	2.677	2.717
70	2.756	2.795	2.835	2.874	2.913	2.953	2.992	3.032	3.071	3.110
80	3.150	3.189	3.228	3.268	3.307	3.346	3.386	3.425	3.465	3.504
90	3.543	3.583	3.622	3.661	3.701	3.740	3.780	3.819	3.858	3.898

Millimeters to inches

1mm = 0.03937in

	0	1	2	3	4	5	6	7	8	9
0		0.039	0.079	0.118	0.157	0.197	0.236	0.276	0.315	0.354
10	0.394	0.433	0.472	0.512	0.551	0.591	0.630	0.669	0.709	0.748
20	0.787	0.827	0.866	0.906	0.945	0.984	1.024	1.063	1.102	1.142
30	1.181	1.220	1.260	1.299	1.339	1.378	1.417	1.457	1.496	1.536
40	1.575	1.614	1.654	1.693	1.732	1.772	1.811	1.850	1.890	1.929
50	1.969	2.008	2.047	2.087	2.126	2.165	2.205	2.244	2.283	2.323
60	2.362	2.402	2.441	2.480	2.520	2.559	2.598	2.638	2.677	2.717
70	2.756	2.795	2.835	2.874	2.913	2.953	2.992	3.032	3.071	3.110
80	3.150	3.189	3.228	3.268	3.307	3.346	3.386	3.425	3.465	3.504
90	3.543	3.583	3.622	3.661	3.701	3.740	3.780	3.819	3.858	3.898

Kilogram to Pound

1kg = 2.2046lb

	0	1	2	3	4	5	6	7	8	9
0		2.20	4.41	6.61	8.82	11.02	13.23	15.43	17.64	19.84
10	22.05	24.25	26.46	28.66	30.86	33.07	35.27	37.48	39.68	41.89
20	44.09	46.30	48.50	50.71	51.91	55.12	57.32	59.5	61.73	63.93
30	66.14	68.34	70.55	72.75	74.96	77.16	79.37	81.57	83.78	85.98
40	88.18	90.39	92.59	94.80	97.00	99.21	101.41	103.62	105.82	108.03
50	110.23	112.44	114.64	116.85	119.05	121.25	123.46	125.66	127.87	130.07
60	132.28	134.48	136.69	138.89	141.10	143.30	145.51	147.71	149.91	152.12
70	154.32	156.53	158.73	160.94	163.14	165.35	167.55	169.76	171.96	174.17
80	176.37	178.57	180.78	182.98	185.19	187.39	189.60	191.80	194.01	196.21
90	198.42	200.62	202.83	205.03	207.24	209.44	211.64	213.85	216.05	218.26

Liter to U.S. Gallon

1 l = 0.2642 U.S.Gal

	0	1	2	3	4	5	6	7	8	9
0		0.264	0.528	0.793	1.057	1.321	1.585	1.849	2.113	2.378
10	2.642	2.906	3.170	3.434	3.698	3.963	4.227	4.491	4.755	5.019
20	5.283	5.548	5.812	6.076	6.340	6.604	6.869	7.133	7.397	7.661
30	7.925	8.189	8.454	8.718	8.982	9.246	9.510	9.774	10.039	10.303
40	10.567	10.831	11.095	11.359	11.624	11.888	12.152	12.416	12.680	12.944
50	13.209	13.473	13.737	14.001	14.265	14.529	14.795	15.058	15.322	15.586
60	15.850	16.115	16.379	16.643	16.907	17.171	17.435	17.700	17.964	18.228
70	18.492	18.756	19.020	19.285	19.549	19.813	20.077	20.341	20.605	20.870
80	21.134	21.398	21.662	21.926	22.190	22.455	22.719	22.983	23.247	23.511
90	23.775	24.040	24.304	24.568	24.832	25.096	25.361	25.625	25.889	26.153

Liter to U.K. Gallon

1 l = 0.21997 U.K.Gal

	0	1	2	3	4	5	6	7	8	9
0		0.220	0.440	0.660	0.880	1.100	1.320	1.540	1.760	1.980
10	2.200	2.420	2.640	2.860	3.080	3.300	3.520	3.740	3.950	4.179
20	4.399	4.619	4.839	5.059	5.279	5.499	5.719	5.939	6.159	6.379
30	6.599	6.819	7.039	7.259	7.479	7.699	7.919	8.139	8.359	8.579
40	8.799	9.019	9.239	9.459	9.679	9.899	10.119	10.339	10.559	10.778
50	10.998	11.281	11.438	11.658	11.878	12.098	12.318	12.528	12.758	12.978
60	13.198	13.418	13.638	13.858	14.078	14.298	14.518	14.738	14.958	15.178
70	15.398	15.618	15.838	16.058	16.278	16.498	16.718	16.938	17.158	17.378
80	17.598	17.818	18.037	18.257	18.477	18.697	18.917	19.137	19.357	19.577
90	19.797	20.017	20.237	20.457	20.677	20.897	21.117	21.337	21.557	21.777

kgf · m to lbf · ft

1kgf · m = 7.233lbf · ft

	0	1	2	3	4	5	6	7	8	9
		7.2	14.5	21.7	28.9	36.2	43.4	50.6	57.9	65.1
10	72.3	79.6	86.8	94.0	101.3	108.5	115.7	123.0	130.2	137.4
20	144.7	151.9	159.1	166.4	173.6	180.8	188.1	195.3	202.5	209.8
30	217.0	224.2	231.5	238.7	245.9	253.2	260.4	267.6	274.9	282.1
40	289.3	296.6	303.8	311.0	318.3	325.5	332.7	340.0	347.2	354.4
50	361.7	368.9	376.1	383.4	390.6	397.8	405.1	412.3	419.5	426.8
60	434.0	441.2	448.5	455.7	462.9	470.2	477.4	484.6	491.8	499.1
70	506.3	513.5	520.8	528.0	535.2	542.5	549.7	556.9	564.2	571.4
80	578.6	585.9	593.1	600.3	607.6	614.8	622.0	629.3	636.5	643.7
90	651.0	658.2	665.4	672.7	679.9	687.1	694.4	701.6	708.8	716.1
100	723.3	730.5	737.8	745.0	752.2	759.5	766.7	773.9	781.2	788.4
110	795.6	802.9	810.1	817.3	824.6	831.8	839.0	846.3	853.5	860.7
120	868.0	875.2	882.4	889.7	896.9	904.1	911.4	918.6	925.8	933.1
130	940.3	947.5	954.8	962.0	969.2	976.5	983.7	990.9	998.2	10005.4
140	1012.6	1019.9	1027.1	1034.3	1041.5	1048.8	1056.0	1063.2	1070.5	1077.7
150	1084.9	1092.2	1099.4	1106.6	1113.9	1121.1	1128.3	1135.6	1142.8	1150.0
160	1157.3	1164.5	1171.7	1179.0	1186.2	1193.4	1200.7	1207.9	1215.1	1222.4
170	1129.6	1236.8	1244.1	1251.3	1258.5	1265.8	1273.0	1280.1	1287.5	1294.7
180	1301.9	1309.2	1316.4	1323.6	1330.9	1338.1	1345.3	1352.6	1359.8	1367.0
190	1374.3	1381.5	1388.7	1396.0	1403.2	1410.4	1417.7	1424.9	1432.1	1439.4

kgf/cm² to lbf/in²1 kgf / cm² = 14.2233 lbf / in²

	0	1	2	3	4	5	6	7	8	9
		14.2	28.4	42.7	56.9	71.1	85.3	99.6	113.8	128.0
10	142.2	156.5	170.7	184.9	199.1	213.4	227.6	241.8	256.0	270.2
20	284.5	298.7	312.9	327.1	341.4	355.6	369.8	384.0	398.3	412.5
30	426.7	440.9	455.1	469.4	483.6	497.8	512.0	526.3	540.5	554.7
40	568.9	583.2	597.4	611.6	625.8	640.1	654.3	668.5	682.7	696.9
50	711.2	725.4	739.6	753.8	768.1	782.3	796.5	810.7	825.0	839.2
60	853.4	867.6	881.8	896.1	910.3	924.5	938.7	953.0	967.2	981.4
70	995.6	1010	1024	1038	1053	1067	1081	1095	1109	1124
80	1138	1152	1166	1181	1195	1209	1223	1237	1252	1266
90	1280	1294	1309	1323	1337	1351	1365	1380	1394	1408
100	1422	1437	1451	1465	1479	1493	1508	1522	1536	1550
110	1565	1579	1593	1607	1621	1636	1650	1664	1678	1693
120	1707	1721	1735	1749	1764	1778	1792	1806	1821	1835
130	1849	2863	1877	1892	1906	1920	1934	1949	1963	1977
140	1991	2005	2020	2034	2048	2062	2077	2091	2105	2119
150	2134	2148	2162	2176	2190	2205	2219	2233	2247	2262
160	2276	2290	2304	2318	2333	2347	2361	2375	2389	2404
170	2418	2432	2446	2460	2475	2489	2503	2518	2532	2546
180	2560	2574	2589	5603	2617	2631	2646	2660	2674	2688
200	2845	2859	2873	2887	2901	2916	2930	2944	2958	2973
210	2987	3001	3015	3030	3044	3058	3072	3086	3101	3115
220	3129	3143	3158	3172	3186	3200	3214	3229	3243	3257
230	3271	3286	3300	3314	3328	3343	3357	3371	3385	3399

TEMPERATURE

Fahrenheit-Centigrade Conversion.

A simple way to convert a fahrenheit temperature reading into a centigrade temperature reading or vice versa is to enter the accompanying table in the center or boldface column of figures.

These figures refer to the temperature in either Fahrenheit or Centigrade degrees.

If it is desired to convert from Fahrenheit to Centigrade degrees, consider the center column as a table of Fahrenheit temperatures and read the corresponding Centigrade temperature in the column at the left.

If it is desired to convert from Centigrade to Fahrenheit degrees, consider the center column as a table of Centigrade values, and read the corresponding Fahrenheit temperature on the right.

°C		°F	°C		°F	°C		°F	°C		°F
-40.4	-40	-40.0	-11.7	11	51.8	7.8	46	114.8	27.2	81	117.8
-37.2	-35	-31.0	-11.1	12	53.6	8.3	47	116.6	27.8	82	179.6
-34.4	-30	-22.0	-10.6	13	55.4	8.9	48	118.4	28.3	83	181.4
-31.7	-25	-13.0	-10.0	14	57.2	9.4	49	120.2	28.9	84	183.2
-28.9	-20	-4.0	-9.4	15	59.0	10.0	50	122.0	29.4	85	185.0
-28.3	-19	-2.2	-8.9	16	60.8	10.6	51	123.8	30.0	86	186.8
-27.8	-18	-0.4	-8.3	17	62.6	11.1	52	125.6	30.6	87	188.6
-27.2	-17	1.4	-7.8	18	64.4	11.7	53	127.4	31.1	88	190.4
-26.7	-16	3.2	-6.7	20	68.0	12.8	55	131.0	32.2	90	194.0
-26.1	-15	5.0	-6.7	20	68.0	12.8	55	131.0	32.2	90	194.0
-25.6	-14	6.8	-6.1	21	69.8	13.3	56	132.8	32.8	91	195.8
-25.0	-13	8.6	-5.6	22	71.6	13.9	57	134.6	33.3	92	197.6
-24.4	-12	10.4	-5.0	23	73.4	14.4	58	136.4	33.9	93	199.4
-23.9	-11	12.2	-4.4	24	75.2	15.0	59	138.2	34.4	94	201.2
-23.3	-10	14.0	-3.9	25	77.0	15.6	60	140.0	35.0	95	203.0
-22.8	-9	15.8	-3.3	26	78.8	16.1	61	141.8	35.6	96	204.8
-22.2	-8	17.6	-2.8	27	80.6	16.7	62	143.6	36.1	97	206.6
-21.7	-7	19.4	-2.2	28	82.4	17.2	63	145.4	36.7	98	208.4
-21.1	-6	21.2	-1.7	29	84.2	17.8	64	147.2	37.2	99	210.2
-20.6	-5	23.0	-1.1	35	95.0	21.1	70	158.0	51.7	125	257.0
-20.0	-4	24.8	-0.6	31	87.8	18.9	66	150.8	40.6	105	221.0
-19.4	-3	26.6	0	32	89.6	19.4	67	152.6	43.3	110	230.0
-18.9	-2	28.4	0.6	33	91.4	20.0	68	154.4	46.1	115	239.0
-18.3	-1	30.2	1.1	34	93.2	20.6	69	156.2	48.9	120	248.0
-17.8	0	32.0	1.7	35	95.0	21.1	70	158.0	51.7	125	257.0
-17.2	1	33.8	2.2	36	96.8	21.7	71	159.8	54.4	130	266.0
-16.7	2	35.6	2.8	37	98.6	22.2	72	161.6	57.2	135	275.0
-16.1	3	37.4	3.3	38	100.4	22.8	73	163.4	60.0	140	284.0
-15.6	4	39.2	3.9	39	102.2	23.3	74	165.2	62.7	145	293.0
-15.0	5	41.0	4.4	40	104.0	23.9	75	167.0	65.6	150	302.0
-14.4	6	42.8	5.0	41	105.8	24.4	76	168.8	68.3	155	311.0
-13.9	7	44.6	5.6	42	107.6	25.0	77	170.6	71.1	160	320.0
-13.3	8	46.4	6.1	43	109.4	25.6	78	172.4	73.9	165	329.0
-12.8	9	48.2	6.7	44	111.2	26.1	79	174.2	76.7	170	338.0
-12.2	10	50.0	7.2	45	113.0	26.7	80	176.0	79.4	172	347.0

SECTION 1 GENERAL

Group 1 Safety hints	1-1
Group 2 Specifications	1-5
Group 3 Periodic replacement	1-15

SECTION 2 REMOVAL AND INSTALLATION OF UNIT

Group 1 Structure	2-1
Group 2 Removal and installation of unit	2-2

SECTION 3 POWER TRAIN SYSTEM

Group 1 Structure and operation	3-1
Group 2 Operation and maintenance	3-30
Group 3 Disassembly and assembly	3-57
Group 4 Adjustment	3-156

SECTION 4 BRAKE SYSTEM

Group 1 Structure and function	4-1
Group 2 Operational checks and troubleshooting	4-20
Group 3 Tests and adjustments	4-22
Group 4 Disassembly and assembly	4-24

SECTION 5 STEERING SYSTEM

Group 1 Structure and function	5-1
Group 2 Operational checks and troubleshooting	5-11
Group 3 Disassembly and assembly	5-13

SECTION 6 HYDRAULIC SYSTEM

Group 1 Structure and function	6-1
Group 2 Operational checks and troubleshooting	6-17
Group 3 Disassembly and assembly	6-21

SECTION 7 ELECTRICAL SYSTEM

Group 1 Component location	7-1
Group 2 Electrical circuit	7-2
Group 3 Component specification	7-13
Group 4 Connector destination	7-14
Group 5 Troubleshooting	7-17

SECTION 8 MAST

Group 1 Structure	8-1
Group 2 Operational checks and troubleshooting	8-5
Group 3 Adjustment	8-8
Group 4 Removal and installation	8-10

GROUP 1 SAFETY HINTS

Careless performing of the easy work may cause injuries.

Take care to always perform work safely, at least observing the following.

- Oil is a dangerous substance. Never handle oil, grease or oily clothes in places where there is any fire or flame.

As preparation in case of fire, always know the location and directions for use of fire extinguishers and other fire fighting equipment.

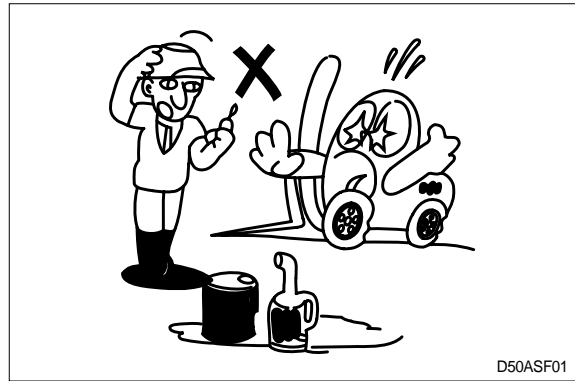

D50ASF01

- Wear well-fitting helmet, safety shoes and working clothes. When drilling, grinding or hammering, always wear protective goggles. Always do up safety clothes properly so that they do not catch on protruding parts of machines. Do not wear oily clothes. When checking, always release battery plug.

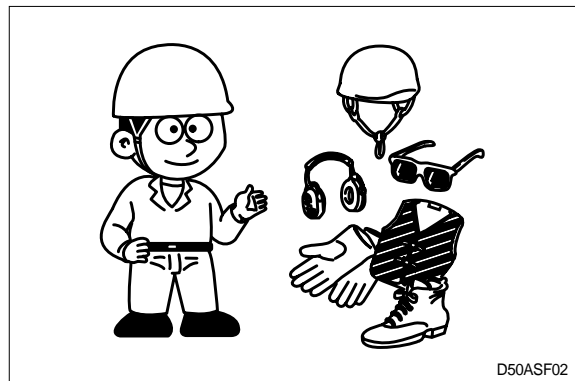

D50ASF02

- Flames should never be used instead of lamps. Never use a naked flame to check leaks or the level of oil or electrolyte.

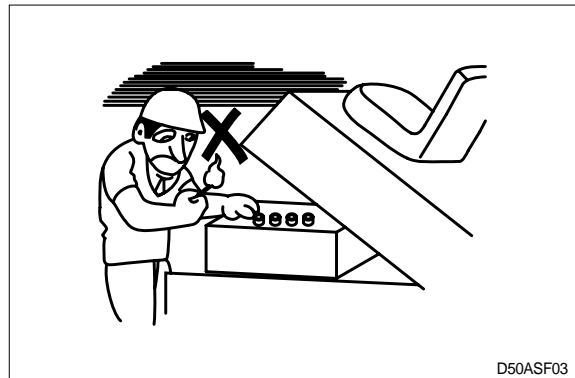

D50ASF03

- Exhaust gas is dangerous. Provide adequate ventilation when working a closed space.

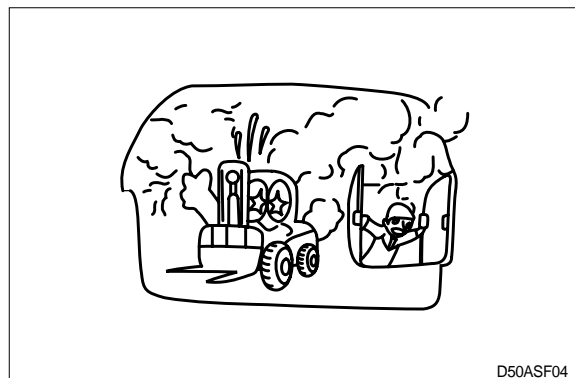

D50ASF04

⚠ Be particularly careful when removing the radiator cap and the hydraulic oil tank filler cap, if this is done immediately after using the machine, there is a danger that boiled oil may spurt out.

- The procedure for releasing the hydraulic pressure is as follows : lower the fork to the ground, and stop the engine(Motor), move the control levers to each position two or three times.

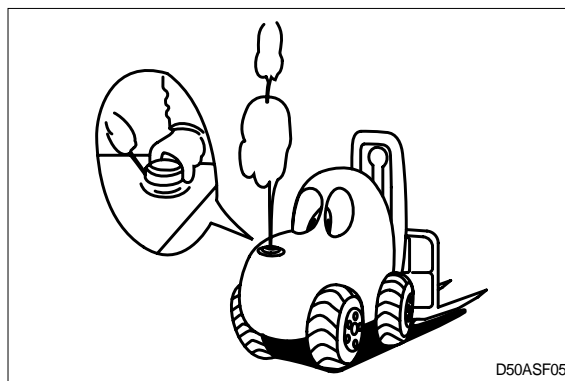

- When working on top of the machine, be careful not to lose your balance and fall.



- Hand a caution sign in the operator's compartment (For example **Do not start** or **Maintenance in progress**).

This will prevent anyone from starting or moving the machine by mistake.

⚠ It is extremely dangerous to try to check the fan belt tension while the engine is running.

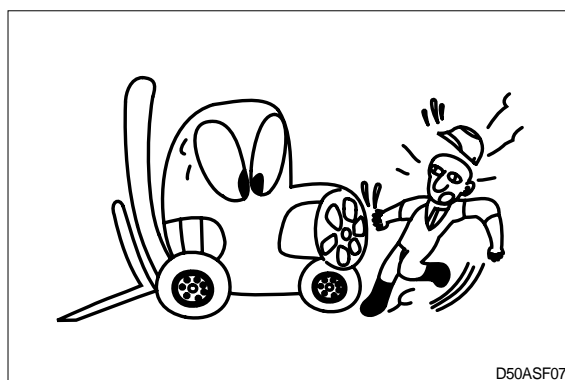

When inspecting the engine is running parts, or near such parts, always stop the engine first.

Before checking or servicing accumulator or piping, depress brake pedal repeatedly to release pressure.

- Park the machine on firm, flat ground.
Lower the fork to the ground and stop the engine.
Return each lever to **NEUTRAL** and apply the brake lock.

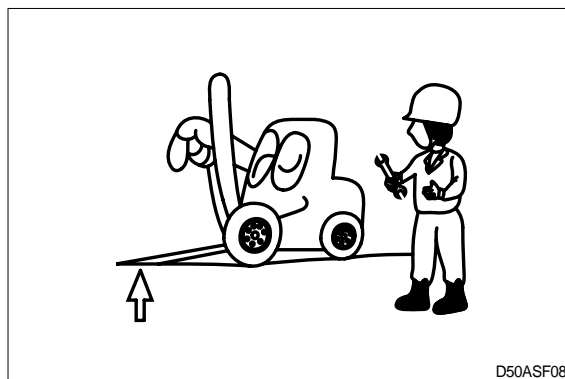

- Immediately remove any oil or grease on the floor of the operator's compartment, or on the handrail. It is very dangerous if someone slips while on the machine.

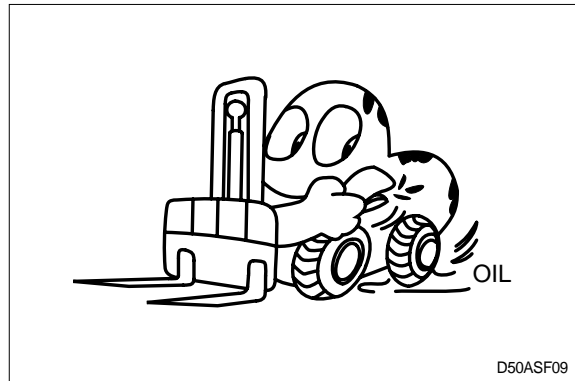

- When working with others, choose a group leader and work according to his instructions. Do not perform any maintenance beyond the agreed work.

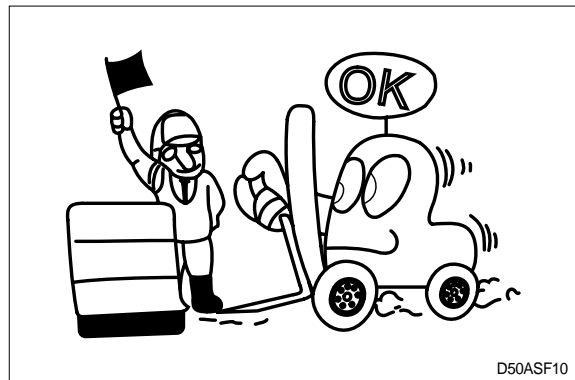

- Unless you have special instructions to the contrary, maintenance should always be carried out with the engine stopped. If maintenance is carried out with the engine running, there must be two men present : one sitting in the operator's seat and the other one performing the maintenance. In such a case, never touch any moving part.



- Always remember that the hydraulic oil circuit is under pressure. When feeding or draining the oil or carrying out inspection and maintenance, release the pressure first.

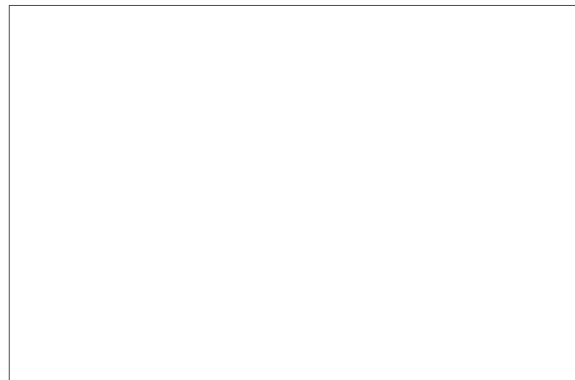

- Thoroughly clean the machine. In particular, be careful to clean the filler caps, grease fittings and the area around the dipsticks. Be careful not to let any dirt or dust into the system.
- Always use HYUNDAI Forklift genuine parts for replacement.
- Always use the grades of grease and oil recommended by HYUNDAI Forklift. Choose the viscosity specified for the ambient temperature.
- Always use pure oil or grease, and be sure to use clean containers.
- When checking or changing the oil, do it in a place free of dust, and prevent any dirt from getting into the oil.
- Before draining the oil, warm it up to a temperature of 30 to 40°C.
- After replacing oil, filter element or strainer, bleed the air from circuit.
- When the strainer is located in the oil filler, the strainer must not be removed while adding oil.
- When changing the oil filter, check the drained oil and filter for any signs of excessive metal particles or other foreign materials.
- When removing parts containing O-ring, gaskets or seals, clean the mounting surface and replace with new sealing parts.
- After injecting grease, always wipe off the oil grease that was forced out.
- Do not handle electrical equipment while wearing wet places, as this can cause electric shock.
- During maintenance, do not allow any unauthorized person to stand near the machine.
- Be sure you fully understand the contents of the operation. It is important to prepare necessary tools and parts and to keep the operating area clean.
- When checking an open gear case, there is a risk of dropping things in. Before removing the covers to inspect such cases, empty everything from your pockets. Be particularly careful to remove wrenches and nuts.
- Way to use dipstick
Push the dipstick fully into the guide, and then pull out.

Carrying out other difficult maintenance work carelessly can cause unexpected accidents. If you consider the maintenance is too difficult, always request the HYUNDAI Forklift distributor to carry out it.

GROUP 2 SPECIFICATIONS

1. MAJOR COMPONENTS

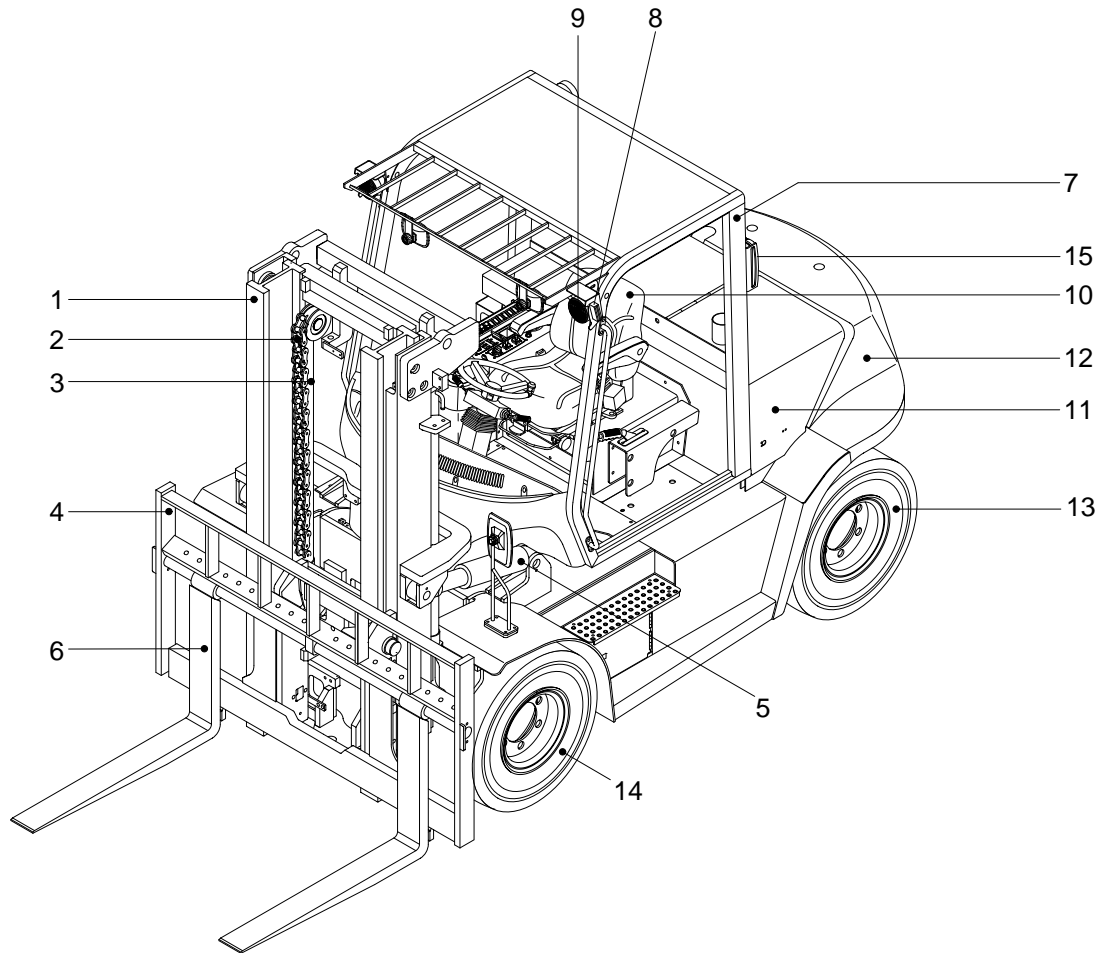

50DEOM54

- | | | |
|-----------------|--------------------|--------------------------|
| 1 Mast | 6 Forks | 11 Bonnet |
| 2 Lift chain | 7 Overhead guard | 12 Counterweight |
| 3 Lift cylinder | 8 Turn signal lamp | 13 Rear wheel |
| 4 Backrest | 9 Head lamp | 14 Front wheel |
| 5 Tilt cylinder | 10 Operator's seat | 15 Rear combination lamp |

2. SPECIFICATIONS

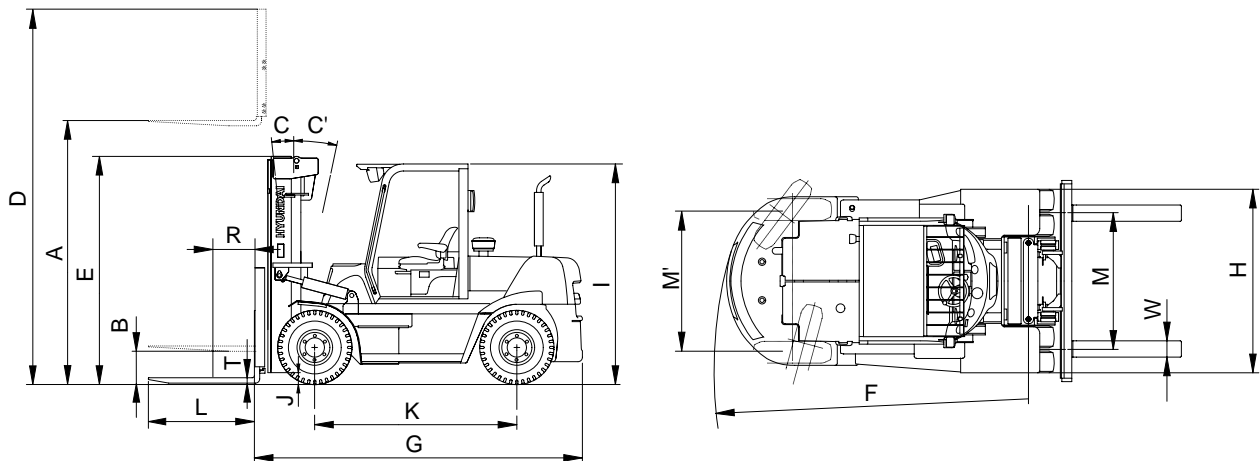

50DESP01

Model		Unit	50D-7E	60D-7E	70D-7E	80D-7E		
Capacity		kg	5000	6000	7000	8000		
Load center		R	mm	←	←	←		
Weight(Unloaded)		kg	8440	9218	9839	11046		
Fork	Lifting height	A	mm	3000	3030	3000	←	
	Free lift	B	mm	140	←	←	145	
	Lifting speed(Unload/Load)		mm/sec	460/440	460/430	450/400	480/420	
	Lowering speed(Unload/Load)		mm/sec	450/500	←	←	←	
	L × W × T	L,W,T	mm	1200 × 150 × 60	1200 × 180 × 60	←	1200 × 180 × 70	
Mast	Tilt angle (forward/backward)		C/C'	degree	15/10	←	←	←
	Max height		D	mm	4275	←	←	4375
	Min height		E	mm	2515	←	←	2675
Body	Travel speed			km/h	35.1	34.9	33.6	34.5
	Gradeability			degree	20.6	18.1	18.8	18.2
	Min turning radius(Outside)		F	mm	3270	3315	3270	3600
ETC	Max hydraulic pressure			kgf/cm ²	188	←	←	←
	Hydraulic oil tank			l	133	←	←	100
	Fuel tank			l	165	←	←	185
Overall length		G	mm	3500	3565	3670	3900	
Overall width		H	mm	2087	←	←	2277	
Overhead guard height		I	mm	2500	←	←	2603	
Ground clearance		J	mm	190	195	←	250	
Wheel base		K	mm	2300	←	←	2500	
Wheel tread front/rear		M, M'	mm	1580/1604	←	←	1632/1700	

3. SPECIFICATION FOR MAJOR COMPONENTS

1) 50D/60D/70D-7E

(1) ENGINE

Item	Unit	Specification
Model	-	HYUNDAI D4DD-C7
Type	-	4 cycle turbocharged diesel type
Cooling Method	-	Water cooling
Number of cylinders and arrangement	-	4 cylinders, In-line
Firing order	-	1-3-4-2
Combustion chamber type	-	Direct injection
Cylinder bore X stroke	mm(in)	104 × 115(4.1 × 4.5)
Piston displacement	cc(cu in)	3907(238)
Compression ratio	-	17.5 : 1
Rated gross horse power	ps/rpm	100/2300
Maximum gross torque at rpm	kgf · m/rpm	38/1600
Engine oil quantity	l (U.S.gal)	8.5(2.2)
Dry weight	kg(lb)	350(772)
High idling speed	rpm	2510 ± 20
Low idling speed	rpm	800 ± 50
Rated fuel consumption	g/ps.hr	140.2(at 1700rpm)
Starting motor	V-kW	24-5
Alternator	V-A	24-50
Battery	V-AH	24-75
Fan belt deflection	mm(in)	10~15(0.39~0.59)

(2) MAIN PUMP

Item	Unit	Specification
Type	-	Fixed displacement gear pump
Capacity	cc/rev	35.6+33+7.6
Maximum operating pressure	bar	210
Rated speed (Max/Min)	rpm	3000/600

(3) MAIN CONTROL VALVE

Item	Unit	Specification
Type	-	Sectional
Operating method	-	Mechanical
Main relief valve pressure	bar	188/153
Flow capacity	lpm	163

(4) POWER TRAIN DEVICES

Item		Specification		
Torque converter	Model	F&S 300*16/4/-1(ZF SACH)		
	Type	3 Element, 1 stage, 2 phase		
	Stall ratio	2.5 : 1		
Transmission	Type	Full auto, Power shift		
	Gear shift(FWD/REV)	3/3		
	Control	Electrical single lever type		
	Overhaul ratio	FWD	1st : 4.578	2nd : 2.396
REV		1st : 4.593	2nd : 2.404	3rd : 0.996
Axle	Type	Front-wheel drive type, fixed location		
	Gear ratio	10.545		
Wheels	Q'ty(FR/RR)	Double : 4/2		
	Front(drive)	8.25-15-14 PR		
	Rear(steer)	8.25-15-14 PR		
Brakes	Travel	Front wheel, Duo-servo/dry, wet disc brake/wet		
	Parking	Ratchet, internal expanding mechanical type		
Steering	Type	Full hydraulic, power steering		
	Steering angle	75.87° to both right and left angle, respectively		

2) 80D-7E
(1) ENGINE

Item	Unit	Specification
Model	-	HYUNDAI D4DD-C7
Type	-	4 cycle turbocharged diesel type
Cooling Method	-	Water cooling
Number of cylinders and arrangement	-	4 cylinders, In-line
Firing order	-	1-3-4-2
Combustion chamber type	-	Direct injection
Cylinder bore X stroke	mm(in)	104 × 115(4.1 × 4.5)
Piston displacement	cc(cu in)	3907(238)
Compression ratio	-	17.5 : 1
Rated gross horse power	ps/rpm	100/2300
Maximum gross torque at rpm	kgf · m/rpm	38/1600
Engine oil quantity	l (U.S.gal)	8.5(2.2)
Dry weight	kg(lb)	350(772)
High idling speed	rpm	2510 ± 20
Low idling speed	rpm	800 ± 50
Rated fuel consumption	g/ps.hr	140.2(at 1700rpm)
Starting motor	V-kW	24-5
Alternator	V-A	24-50
Battery	V-AH	24-75
Fan belt deflection	mm(in)	10~15(0.39~0.59)

(2) MAIN PUMP

Item	Unit	Specification
Type	-	Fixed displacement gear pump
Capacity	cc/rev	35.6+33+7.6
Maximum operating pressure	bar	210
Rated speed (Max/Min)	rpm	3000/600

(3) MAIN CONTROL VALVE

Item	Unit	Specification
Type	-	Sectional
Operating method	-	Mechanical
Main relief valve pressure	bar	188/153
Flow capacity	lpm	163

(4) POWER TRAIN DEVICES

Item		Specification		
Torque converter	Model	F&S 300*16/4/-1(ZF SACH)		
	Type	3 Element, 1 stage, 2 phase		
	Stall ratio	2.5 : 1		
Transmission	Type	Full auto, Power shift		
	Gear shift(FWD/REV)	3/3		
	Control	Electrical single lever type		
	Overhaul ratio	FWD	1st : 4.578	2nd : 2.396
REV		1st : 4.593	2nd : 2.404	3rd : 0.996
Axle	Type	Front-wheel drive type, fixed location		
	Gear ratio	12.4		
Wheels	Q'ty(FR/RR)	Double : 4/2		
	Front(drive)	8.25-15-14 PR		
	Rear(steer)	8.25-15-14 PR		
Brakes	Travel	Front wheel, Duo-servo/dry, wet disc brake/wet		
	Parking	Ratchet, internal expanding mechanical type		
Steering	Type	Full hydraulic, power steering		
	Steering angle	75.87° to both right and left angle, respectively		

4. TIGHTENING TORQUE FOR MAJOR COMPONENTS

NO	ITEMS		SIZE	kgf · m	lbf · ft
1	Engine	Engine mounting bolt, nut	M16 × 2.0	7.5	54
2		Radiator mounting bolt, nut	M10 × 1.5	6.9 ± 1.4	50 ± 10
3		Torque converter mounting bolt	M10 × 1.5	6.9 ± 1.4	50 ± 10
4	Hydraulic system	MCV mounting bolt, nut	M12 × 1.75	12.8 ± 3.0	93 ± 22
5		Steering unit mounting bolt	M10 × 1.5	6.9 ± 1.4	50 ± 10
6	Power train system	Transmission mounting bolt, nut	M16 × 2.0	7.5	54
7		Drive axle mounting bolt, nut	M24 × 3.0	100 ± 15	723 ± 108
8		Steering axle mounting bolt, nut	M18 × 2.5	41.3 ± 6.2	300 ± 45
9		Front wheel mounting nut	M22 × 1.5	61.2 ± 9.2	448 ± 67
10		Rear wheel mounting nut	M22 × 1.5	61.2 ± 9.2	448 ± 67
11	Others	Counterweight mounting bolt	M30 × 3.5	120 ± 15	1555 ± 239
12		Operator's seat mounting nut	M 8 × 1.25	2.5 ± 0.5	18.1 ± 3.6
13		Head guard mounting bolt	M12 × 1.75	12.8 ± 3.0	93 ± 22

5. TORQUE CHART

Use following table for unspecified torque.

1) BOLT AND NUT

(1) Coarse thread

Bolt size	8T		10T	
	kgf · m	lbf · ft	kgf · m	lbf · ft
M 6 × 1.0	0.85 ~ 1.25	6.15 ~ 9.04	1.14 ~ 1.74	8.2 ~ 12.6
M 8 × 1.25	2.0 ~ 3.0	14.5 ~ 21.7	2.7 ~ 4.1	19.5 ~ 29.7
M10 × 1.5	4.0 ~ 6.0	28.9 ~ 43.4	5.5 ~ 8.3	39.8 ~ 60.0
M12 × 1.75	7.4 ~ 11.2	53.5 ~ 81.0	9.8 ~ 15.8	70.9 ~ 114
M14 × 2.0	12.2 ~ 16.6	88.2 ~ 120	16.7 ~ 22.5	121 ~ 163
M16 × 2.0	18.6 ~ 25.2	135 ~ 182	25.2 ~ 34.2	182 ~ 247
M18 × 2.0	25.8 ~ 35.0	187 ~ 253	35.1 ~ 47.5	254 ~ 344
M20 × 2.5	36.2 ~ 49.0	262 ~ 354	49.2 ~ 66.6	356 ~ 482
M22 × 2.5	48.3 ~ 63.3	349 ~ 458	65.8 ~ 98.0	476 ~ 709
M24 × 3.0	62.5 ~ 84.5	452 ~ 611	85.0 ~ 115	615 ~ 832
M30 × 3.0	124 ~ 168	898 ~ 1214	169 ~ 229	1223 ~ 1656
M36 × 4.0	174 ~ 236	1261 ~ 1704	250 ~ 310	1808 ~ 2242

(2) Fine thread

Bolt size	8T		10T	
	kgf · m	lbf · ft	kgf · m	lbf · ft
M 8 × 1.0	2.2 ~ 3.4	15.9 ~ 24.6	3.0 ~ 4.4	21.7 ~ 31.8
M10 × 1.2	4.5 ~ 6.7	32.5 ~ 48.5	5.9 ~ 8.9	42.7 ~ 64.4
M12 × 1.25	7.8 ~ 11.6	56.4 ~ 83.9	10.6 ~ 16.0	76.7 ~ 116
M14 × 1.5	13.3 ~ 18.1	96.2 ~ 131	17.9 ~ 24.1	130 ~ 174
M16 × 1.5	19.9 ~ 26.9	144 ~ 195	26.6 ~ 36.0	192 ~ 260
M18 × 1.5	28.6 ~ 43.6	207 ~ 315	38.4 ~ 52.0	278 ~ 376
M20 × 1.5	40.0 ~ 54.0	289 ~ 391	53.4 ~ 72.2	386 ~ 522
M22 × 1.5	52.7 ~ 71.3	381 ~ 516	70.7 ~ 95.7	511 ~ 692
M24 × 2.0	67.9 ~ 91.9	491 ~ 665	90.9 ~ 123	658 ~ 890
M30 × 2.0	137 ~ 185	990 ~ 1339	182 ~ 248	1314 ~ 1796
M36 × 3.0	192 ~ 260	1390 ~ 1880	262 ~ 354	1894 ~ 2562

2) PIPE AND HOSE(FLARE TYPE)

Thread size(PF)	Width across flat(mm)	kgf · m	lbf · ft
1/4"	19	4	28.9
3/8"	22	5	36.2
1/2"	27	9.5	68.7
3/4"	36	18	130
1"	41	21	152
1-1/4"	50	35	253

3) PIPE AND HOSE(ORFS TYPE)

Thread size(UNF)	Width across flat(mm)	kgf · m	lbf · ft
9/16-18	19	4	28.9
11/16-16	22	5	36.2
13/16-16	27	9.5	68.7
1-3/16-12	36	18	130
1-7/16-12	41	21	152
1-11/16-12	50	35	253

4) FITTING

Thread size(PF)	Width across flat(mm)	kgf · m	lbf · ft
1/4"	19	4	28.9
3/8"	22	5	36.2
1/2"	27	9.5	68.7
3/4"	36	18	130
1"	41	21	152
1-1/4"	50	35	253

6. RECOMMENDED LUBRICANTS

Use only oils listed below or equivalent.

Do not mix different brand oil.

Service point	Kind of fluid	Capacity l (U.S.gal)	Ambient temperature °C (°F)						
			-20 (-4)	-10 (14)	0 (32)	10 (50)	20 (68)	30 (86)	40 (104)
Engine oil pan	Engine oil	8.5 (2.2)	SAE 30						
			SAE 10W						
			SAE 10W-30						
			SAE 15W-40						
Torque converter transmission	T/M oil	18 (4.8)	ATF DEXRON III						
Axle	Gear oil	12.5 (3.3)	SAE 80W-90/API GL-5(DRY), MOBILFLUID 424(WET)						
Hydraulic tank	Hydraulic oil	105 (27.7)	ISO VG32						
			ISO VG46						
			ISO VG68						
Fuel tank	Diesel fuel	150 (39.6)	ASTM D975 No.1						
			ASTM D975 No.2						
Fitting (Grease nipple)	Grease	-	NLGI No.1						
			NLGI No.2						
Brake reservoir tank	Hyd oil	-	DOT 3(DRY), AZOLA ZS10(Hydraulic oil SAE 10W : WET)						
Radiator	Antifreeze:Water 50:50	17 (4.5)	Ethylene glycol base permanent type						

NOTES :

- ① SAE numbers given to engine oil should be selected according to ambient temperature.
- ② For engine oil used in engine oil pan, use SAE 10W oil when the temperature at the time of engine start up is below 0°C, even if the ambient temperature in daytime is expected to rise to 10°C or more.
- ③ If any engine oil of API service class CF is used instead of class CH4 engine oil, the frequency of oil change must be doubled.

GROUP 3 PERIODIC REPLACEMENT

For operation safety, never fail to perform periodic maintenance or make periodic replacement of the consumable parts listed in the following.

These parts may deteriorate in time and are susceptible to wear. It is difficult to estimate the degree of wear at time of periodic maintenance; therefore, even if no apparent wear is found, always replace with new parts within the prescribed period of replacement(Or earlier if trouble is found).

Note that periodic replacement has nothing to do with guarantee service.

No.	Description	Period of replacement
1	Master cylinder and wheel cylinder caps, dust seals	Every 1 year
2	Brake hose or tube	Every 1 or 2 years
3	Brake reservoir tank and tube	Every 2 to 4 years
4	Power steering hose	Every 2 years
5	Stop lamp switch(Oil pressure type)	Every 2 years
6	Fuel hose	Every 2 to 4 years
7	Rubber parts of power steering	Every 2 to 4 years
8	Lift chain	Every 2 to 4 years
9	Hose of load handling	Every 1 or 2 years

GROUP 1 STRUCTURE

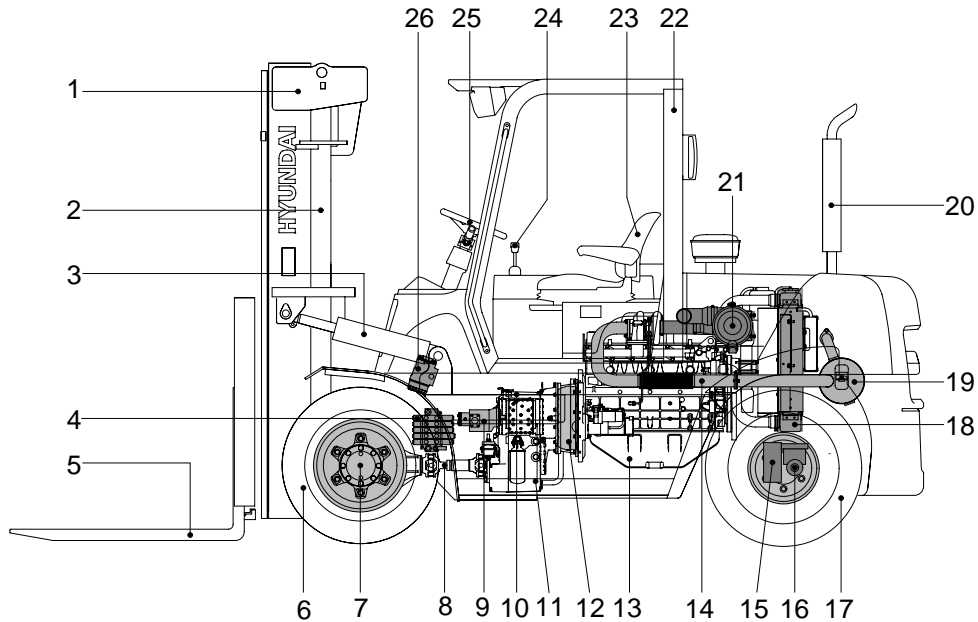

50DEOM21

- | | | |
|-------------------|----------------------|-------------------|
| 1 Mast | 10 Priority valve | 19 Muffler |
| 2 Lift cylinder | 11 Transmission | 20 Silencer |
| 3 Tilt cylinder | 12 Torque converter | 21 Air cleaner |
| 4 Control valve | 13 Engine | 22 Overhead guard |
| 5 Fork | 14 Exhaust pipe | 23 Seat |
| 6 Front wheel | 15 Steering axle | 24 Steering wheel |
| 7 Drive axle | 16 Steering cylinder | 25 Control lever |
| 8 Propeller shaft | 17 Rear wheel | 26 Steering unit |
| 9 Hydraulic pump | 18 Radiator | |

GROUP 2 REMOVAL AND INSTALLATION OF UNIT

Remove and install following units as explained in the flow chart.

1. MAST

1) REMOVAL

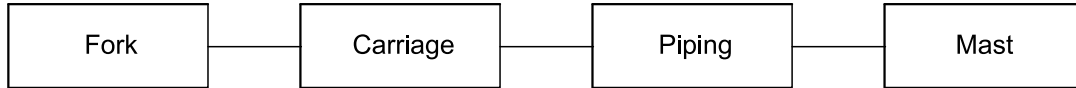

(1) SHAFT TYPE FORKS

- ① Lower the fork carriage until the forks are approximately 25mm(1in) from the floor.
 - ② Release fork retainer and remove cover.
 - ③ Slide one hanger bar at a time out of carriage assembly.
 - ④ Remove only one fork at a time.
- ※ On larger forks it may be necessary to use a block of wood.

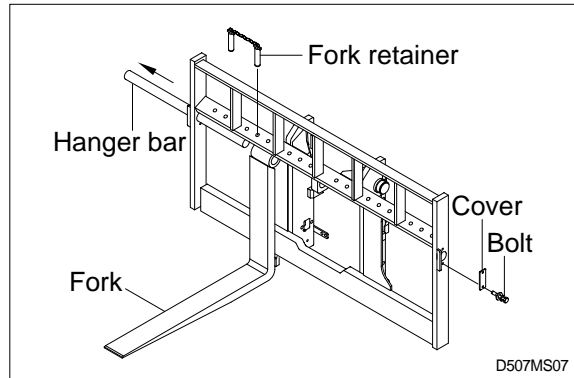

(2) HOOK ON TYPE FORKS(OPTION)

- ① Lower the fork carriage until the forks are approximately 25mm(1in) from the floor.
 - ② Release fork anchor pins and slide one fork at a time toward the center of the carriage where a notch has been cut in the bottom plate for easy fork removal.
 - ③ Remove only one fork at a time.
- ※ On larger forks it may be necessary to use a block of wood.

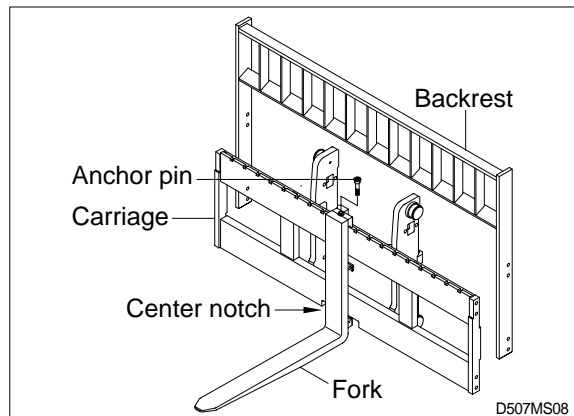

(3) BACKREST(HOOK ON TYPE)

- ① Remove bolts securing backrest to fork carriage lift backrest straight up and remove it from carriage.

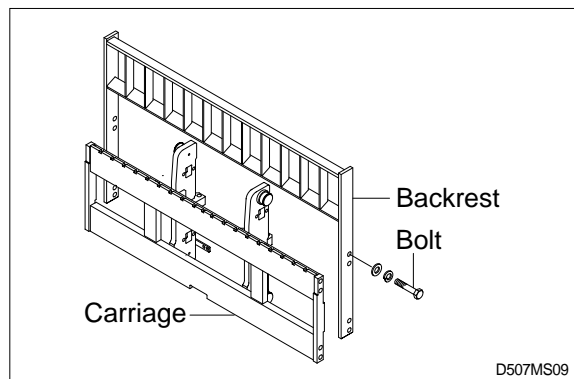

(4) CARRIAGE

- ① With the mast vertical, raise the carriage high enough to place blocks under the load forks. This is done to create slack in the load chains when the carriage is lowered. Lower the carriage all the way down to the floor. Make sure the carriage is level, this will prevent any binding when the mast is raised.

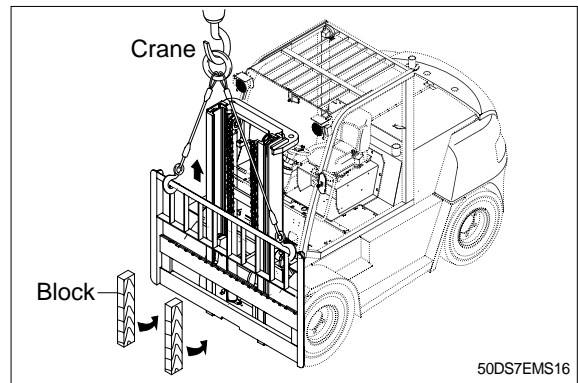

- ② While supporting lift chains, remove the split pin and nuts from the chain anchor bolts of stationary upright.

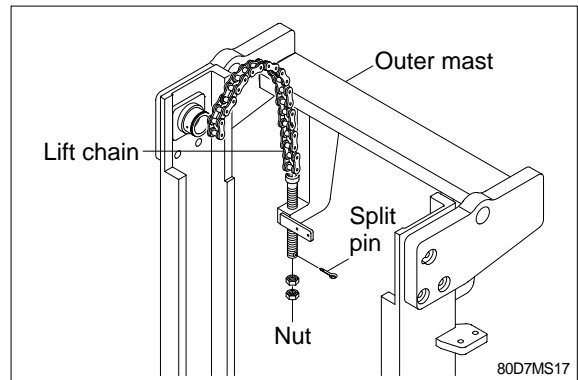

- ③ Pull the chains out of the sheaves and drape them over the front of the carriage.

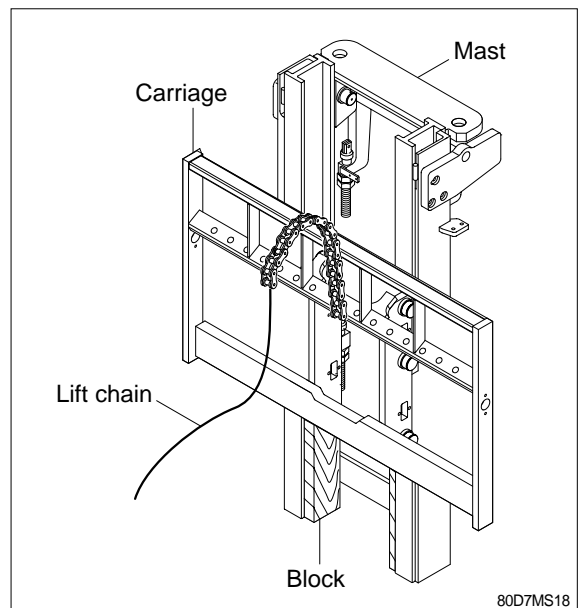

- ④ Slowly raise inner mast upright until mast clears top of fork carriage. Move carriage to work area and lower the mast.

▲ Make sure that carriage remains on floor and does not bind while mast is being raised.

- ※ Inspect all parts for wear or damage. Replace all worn or damaged parts.

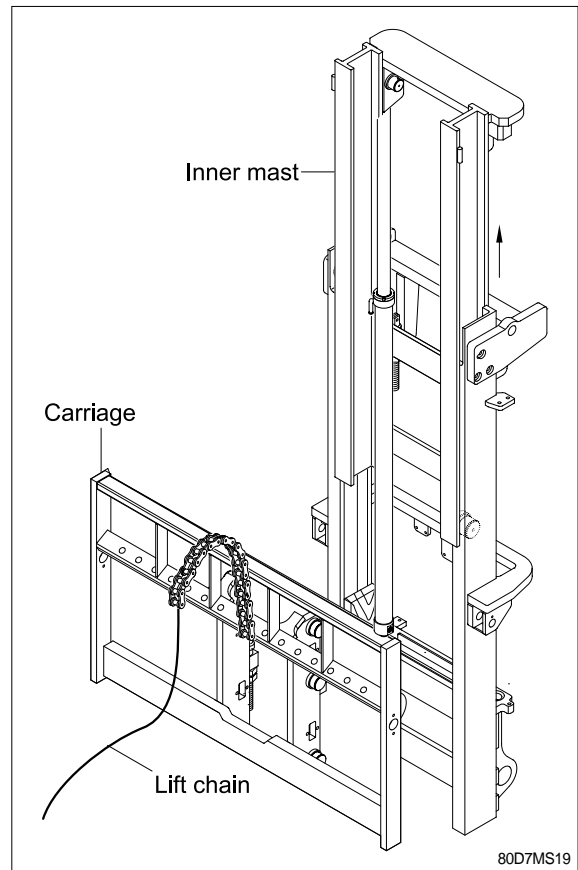

(5) PIPING

- ① Remove the bulk hoses and clamps attached to the cylinder.
- ② Remove the return hose from the down control valve.

- ※ Put blind plugs in the piping immediately after removing hoses.

This prevents the hydraulic oil from flowing out and also prevents dust and dirt from getting in.

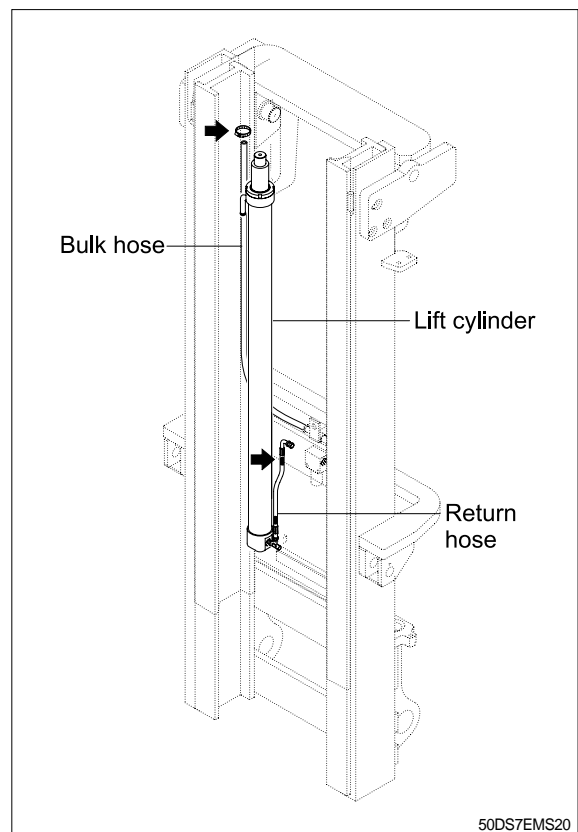

(6) LIFT CYLINDER

- ① Loosen and remove hexagon bolts and washers securing lift cylinders to inner mast.
- ② Bind the lift cylinder with overhead hoist rope and pull up so that the rope has no slack or binding.

▲ Make sure the lift cylinder be tightened firmly for safety.

- ③ Loosen and remove hexagon bolts and nuts securing lift cylinders to outer mast.
- ④ Using an overhead hoist, slowly raise the inner mast high enough to clear lift cylinder.
- ⑤ Using an overhead hoist, draw out lift cylinder carefully and put down on the work floor.

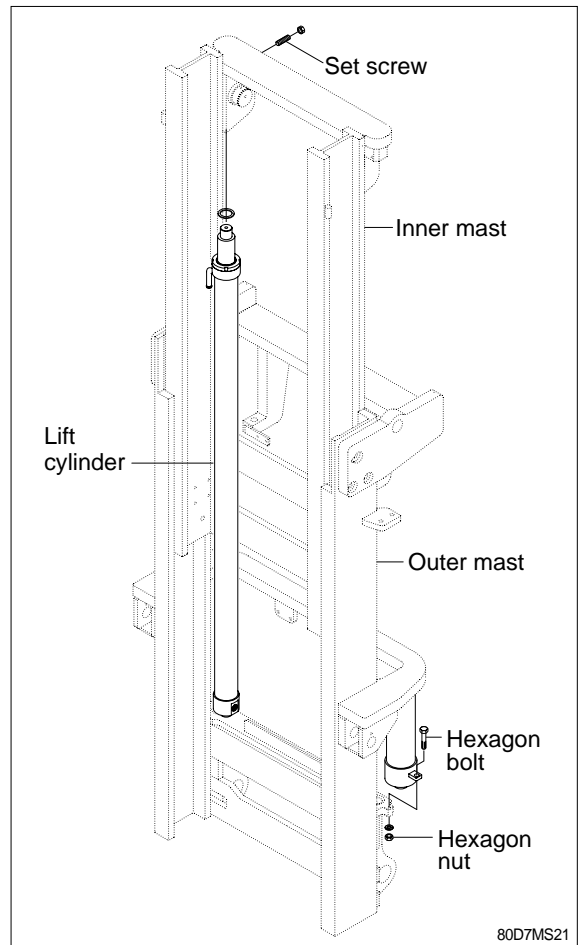

(7) INNER MAST

- ① Using an overhead hoist, raise the inner mast straight and carefully draw out of outer mast section.

▲ Be careful the mast not to swing or fall.

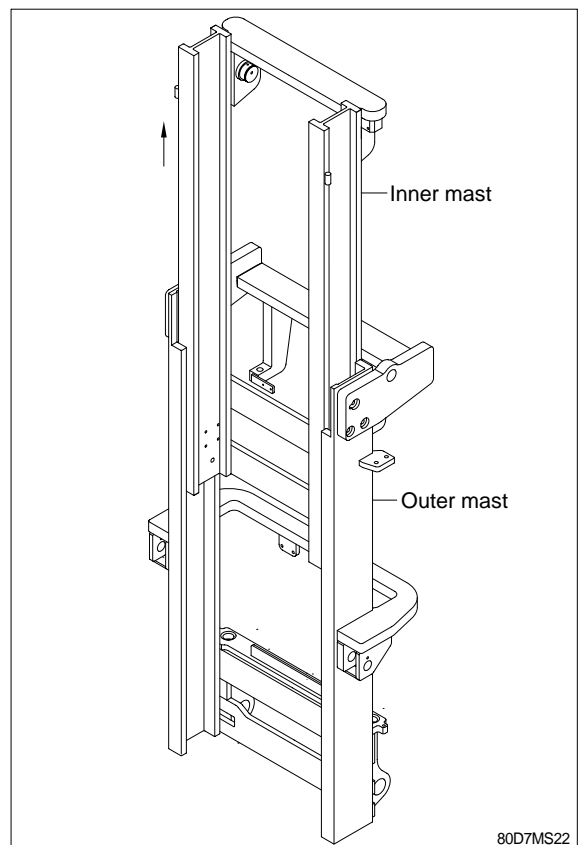

(8) TILT CYLINDER PIN

(9) MAST SUPPORT PIN

Attach a crane to the stay at the top of the outer mast, and raise it.

Remove the mounting bolts and pins from drive axle, then slowly raise outer mast.

- ※ This operation is carried out under the machine, so use a pit, or if there is no pit, jack up the machine and loosen with an impact wrench.

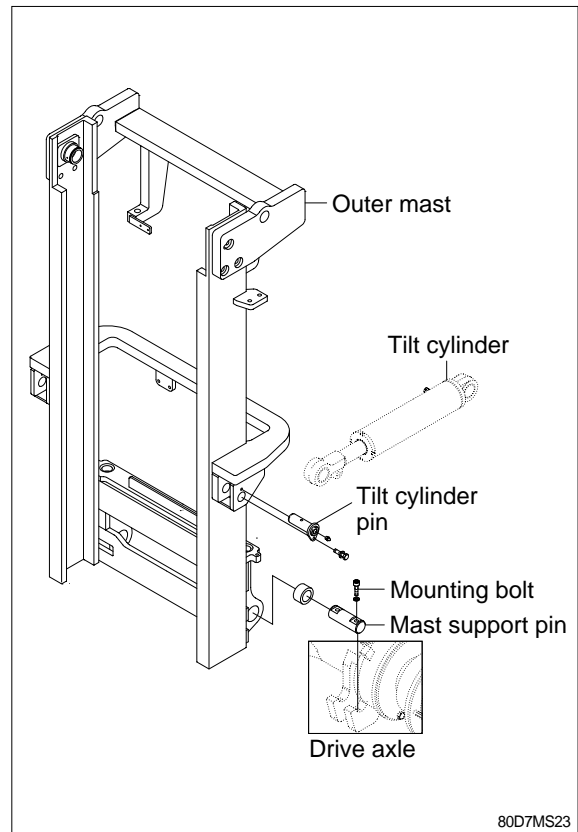

2) INSTALLATION

After assembling mast components totally without piping connections, install mast assembly to the equipment.

※ Installation procedure for each of mast component is the reverse of the removal procedure.

(1) MAST SUPPORT PIN

- ① Check the mast support pins for wear, then install pins into the mast support bracket and drive axle.
- ② Jack up the machine so that the front is raised and then using an overhead hoist assemble outer mast to drive axle unit.
- ③ Tighten mounting socket bolts to drive axle unit.
 - Tightening torque : 49.2~66.6kgf · m(355~481lbf · ft)

(2) TILT CYLINDER PIN

Hold the mast with a crane, operate the tilt control lever and align the holes, then knock the pin.

(3) LIFT CYLINDER INSTALLATION AND ADJUSTMENT

- ① Assemble the lift cylinder inside the outer mast, then tighten the stopper bolt. If the cylinder assembly has been replaced, adjust as follows so that the left and right cylinders are synchronized at the maximum lifting height.
 - ② Assemble the cylinder rod to the inner mast, and check the left-to-right play of the mast at the maximum lifting height.
- ※ If play is to LEFT, install adjustment shim to LEFT cylinder.
- ※ If play is to RIGHT, install adjustment shim to RIGHT cylinder.
- Shim thickness : 1.0mm(0.04in)

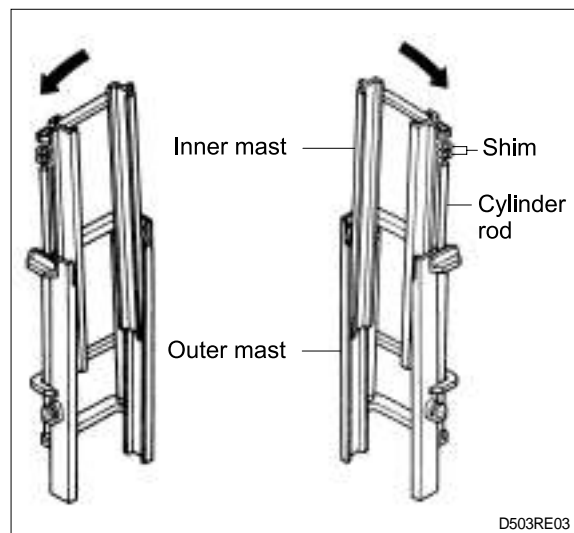

D503RE03

2. POWER TRAIN ASSEMBLY

1) REMOVAL

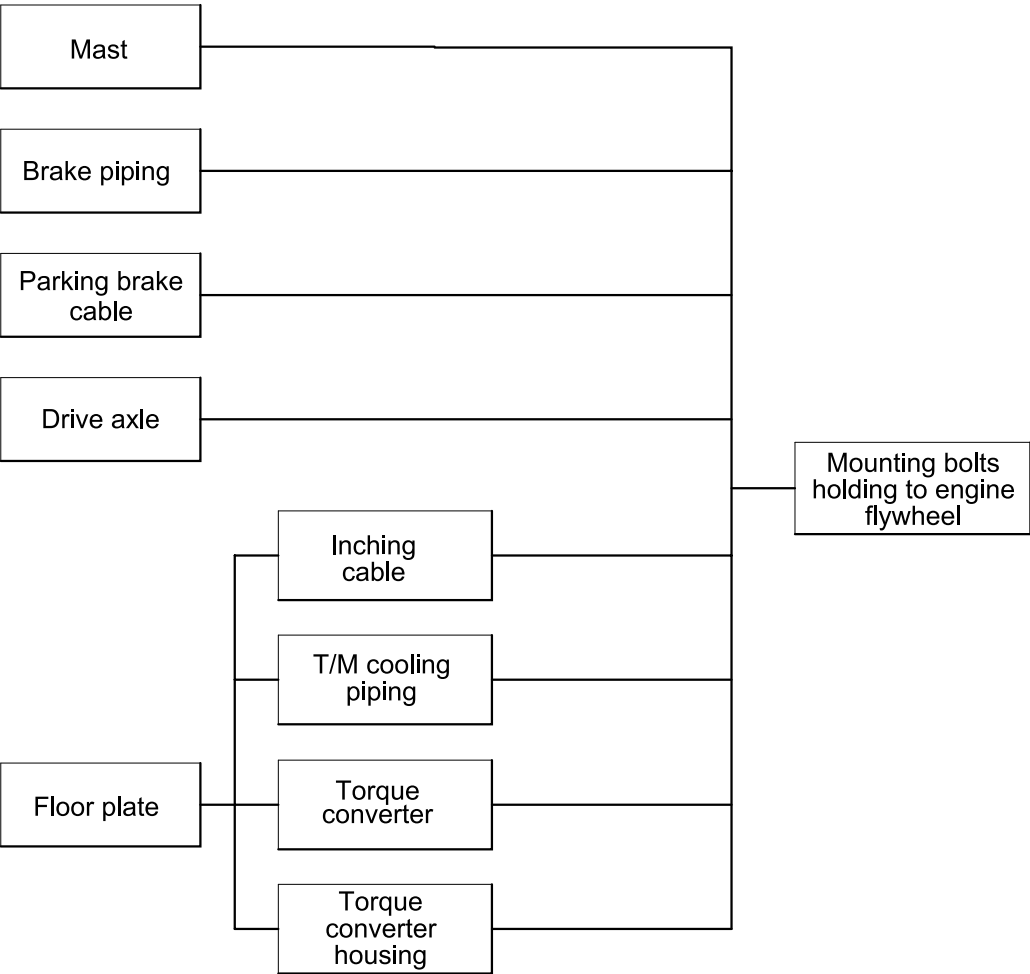

D503RE04

(1) Mast

Refer to section on mast(Page 2-2)

(2) Brake piping

Disconnect the brake piping from the wheel cylinder end.

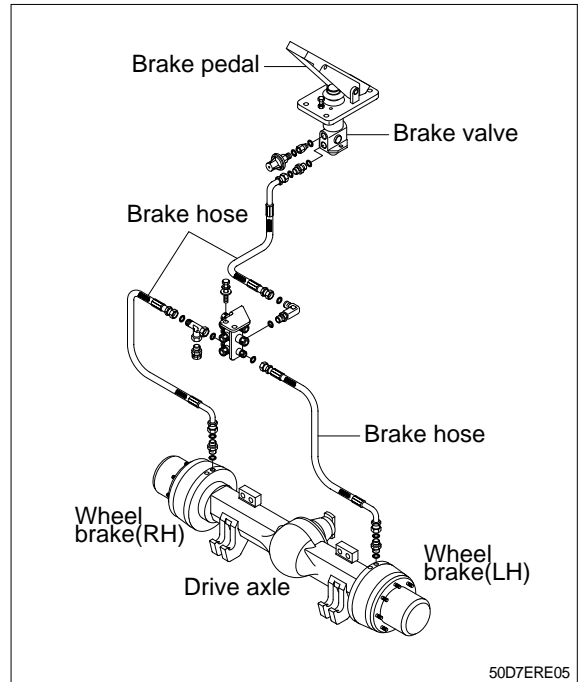

(3) Parking brake cable

Disconnect parking brake cable from the wheel brake assembly.

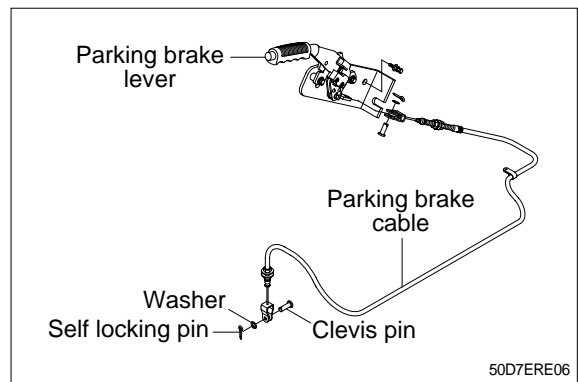

(4) Drive axle

※ Before removing the drive axle unit, drain all of the oil from the axle.

- ① Attach a crane to the tilt cylinder notches on the dashboard and raise the machine.
- ② Loosen hexagonal bolts connecting drive axle to propeller shaft.
- ③ Put the block under the front axle and support under the drive axle with a truck.

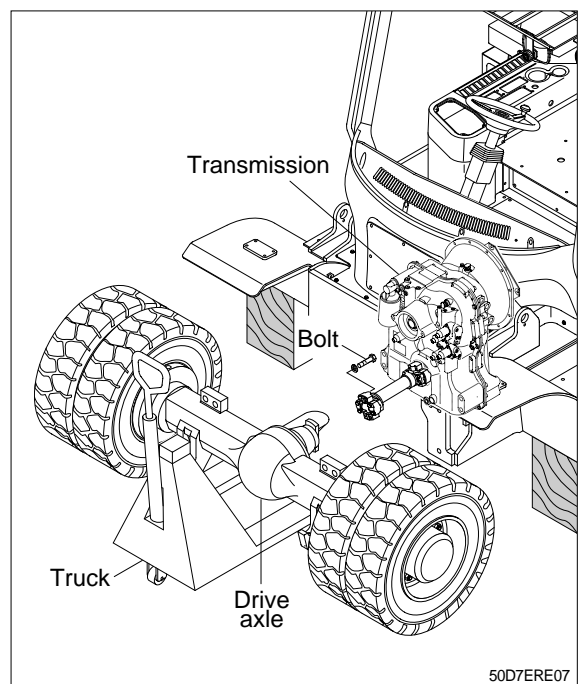

- ④ Remove drive axle mounting bolts from the frame and then slowly pull out the truck with drive axle to the front.

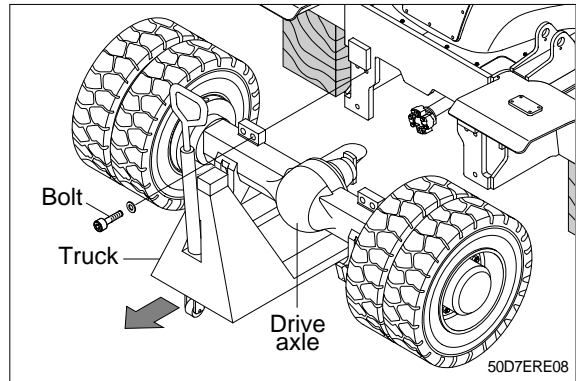

- ⑤ Remove propeller shaft from the transmission by loosening the mounting bolts.

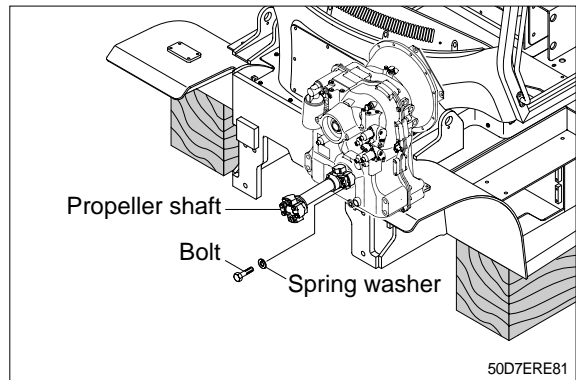

(5) Inching linkage

Remove the nut, clevis pins and self locking pin.

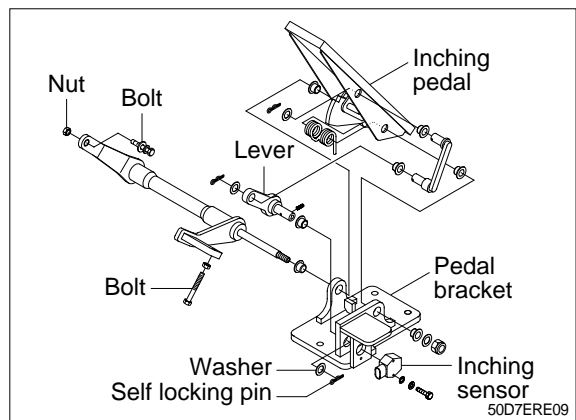

(6) Transmission cooling piping

- ① Disconnect cooling hose and connector from the transmission.
- ※ Make sure that the coolant be drained from the hose.

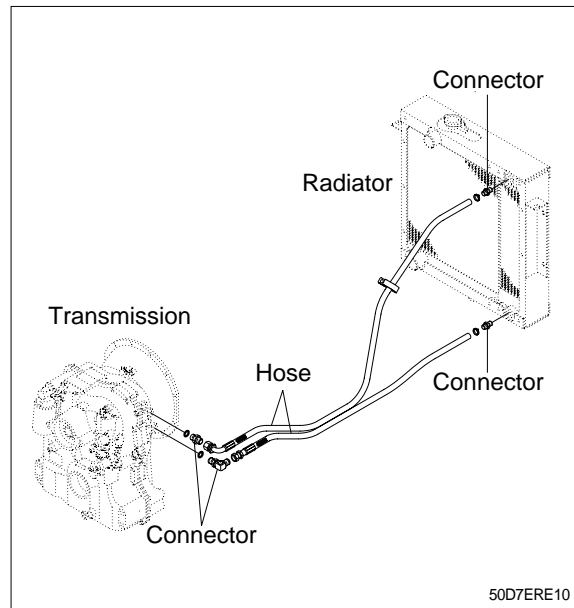

(7) Torque converter

- ① Remove the cover on bottom face of the torque converter housing then remove the 4 mounting bolts installed on the engine flywheel. To rotate the flywheel, remove 1 mounting bolt, then insert a turning tool in the mounting hole. One man must turn the engine fan by hand while the other turns the flywheel.

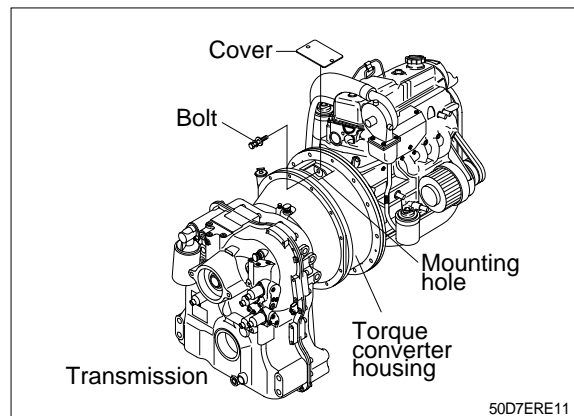

(8) Mounting bolts holding to flywheel housing

- ① Remove the transmission assembly from the torque converter housing by loosening the mounting bolts. Remove torque converter housing from the engine flywheel by loosening the mounting bolts and pins.

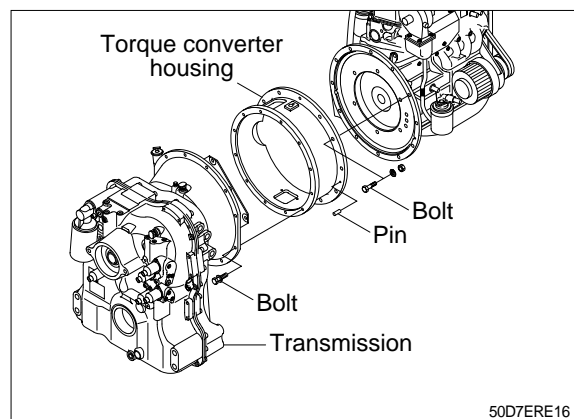

- ② Using a moving truck slowly, pull out transmission assembly to the front.

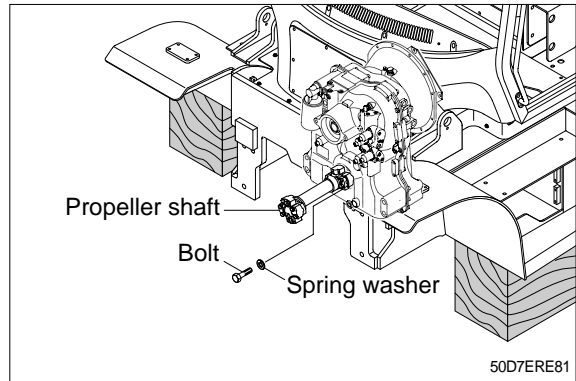

2) INSTALLATION

Installation is the reverse order to removal, but be careful of the following points.

- (1) Tightening torque of mounting bolt for torque converter housing.
- 5.8~8.3kgf · m (42.0~60.0lbf · ft)

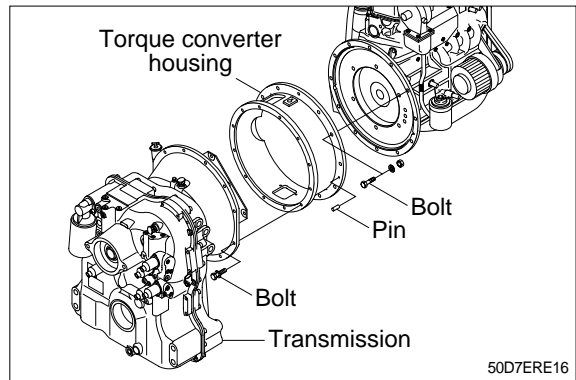

- (2) Tightening torque of mounting bolt for drive axle.
- 85~115kgf · m (615~832lbf · ft)

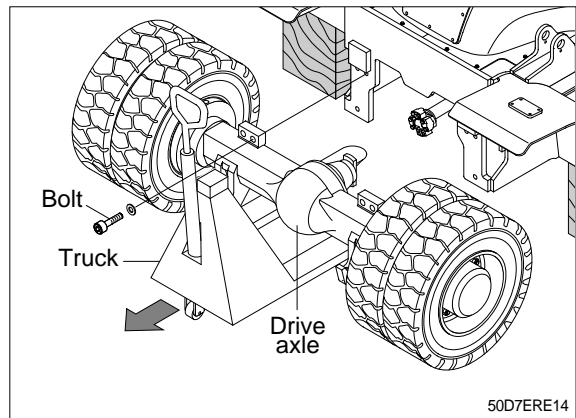

- (3) Tightening torque of mounting bolt for transmission and propeller shaft.
· 6.3~7.7kgf · m (45.6~55.6lbf · ft)

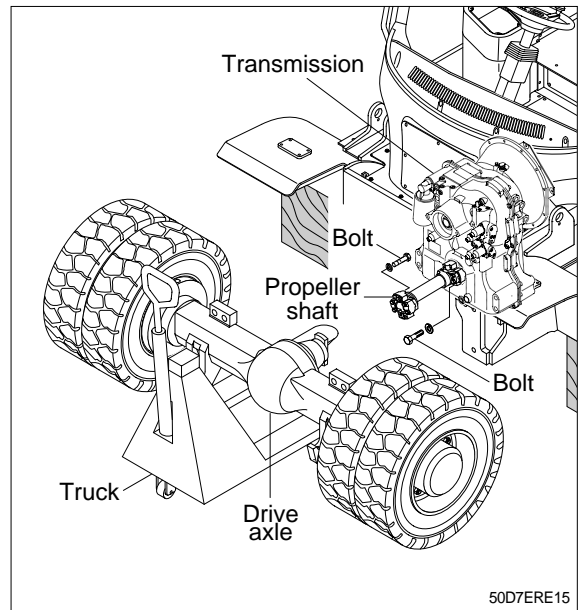

3. ENGINE

Lever the torque converter, transmission and front axle inside the frame, then remove the engine assembly.

1) REMOVAL

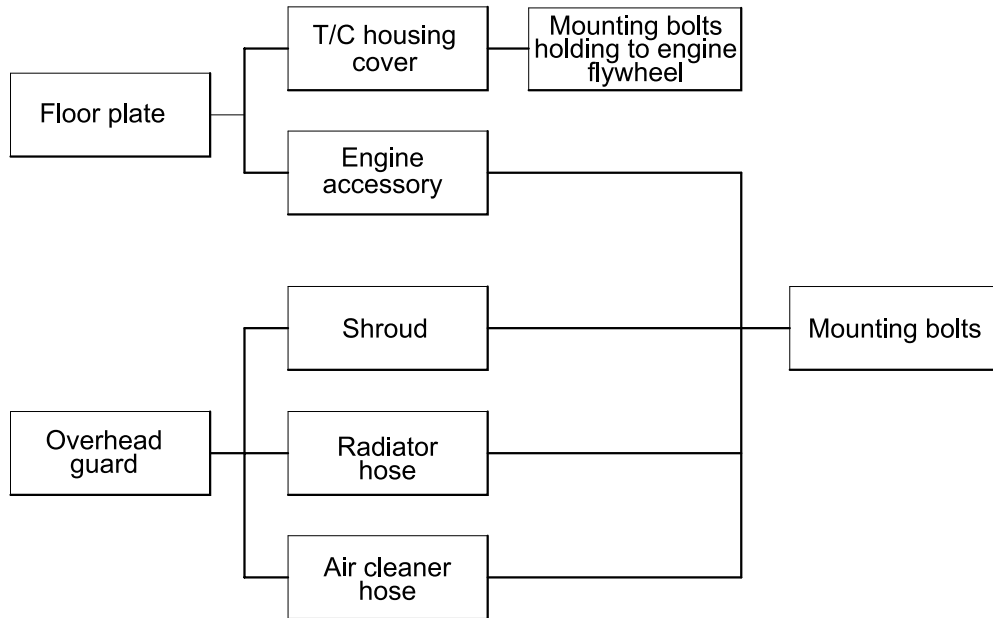

D503RE25

(1) Overhead guard

Tilt the overhead guard.

※ Refer to page 7-26 for operator's manual.

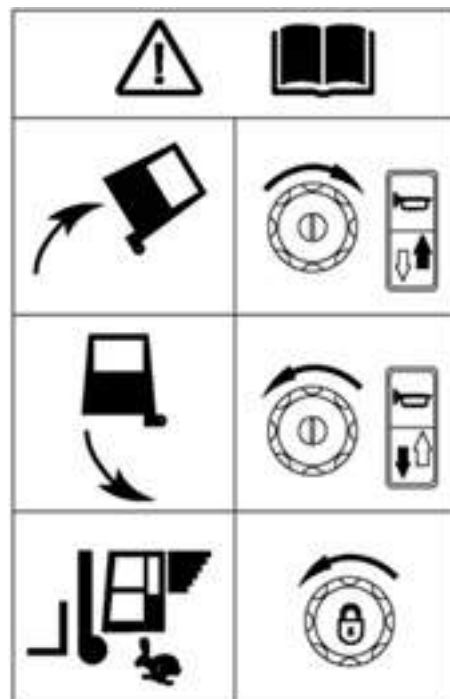

50DEM166

- (2) Remove the torque converter housing cover and mounting bolts installed to flywheel housing.

For details, see page 2-12.

(3) Engine accessory

Remove all wiring harnesses, cables and hoses around the engine, dashboard and frame.

- ① Wiring harness to alternator and starter.
- ② Wiring harness for oil pressure and engine water temperature gauges.
- ③ Cables for meters, buttons and accelerator pedal.
- ④ Hoses to fuel tank and air cleaner.
- ⑤ Exhaust pipe.

(4) Radiator hose

Open the drain valve of the radiator and drain the cooling water, then remove the radiator hose.

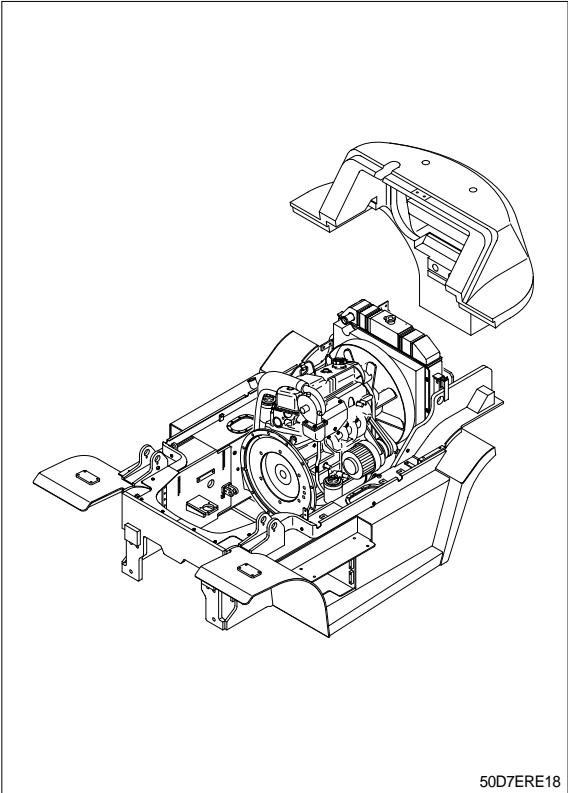

(5) Mounting bolt

Attach a crane to the engine hook and raise, then remove mounting bolts. Raise the engine slightly, slide towards the radiator, then lift up.

- ※ When sliding the engine, be careful of the collision engine and radiator.

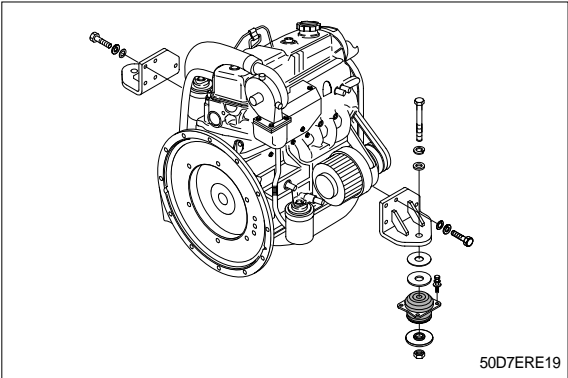

2) INSTALLATION

Installation is the reverse order of removal, but be careful of the following points.

- (1) Tighten the engine mounting bolts and nuts.
- (2) Tighten the engine mounting bracket bolts.
 - ※ Do not remove the bolts unless necessary. Loctite is coated over the threads of bolt. So, once the bolts were removed, coat them with loctite(#243) when installing.
 - ※ Before installing the bolts, loctite in the holes should be removed by a tap.

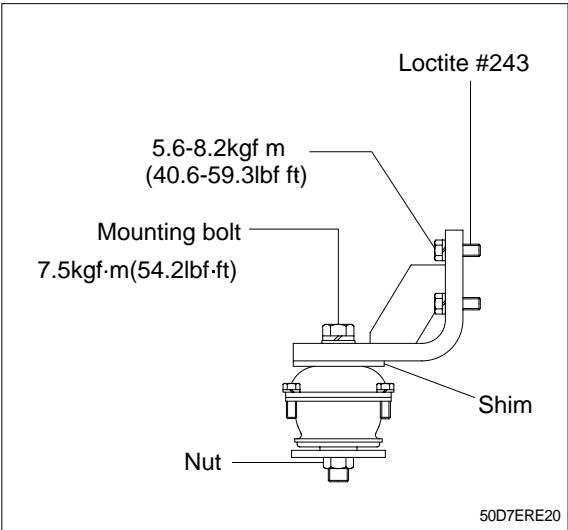

(3) Tightening torque of mounting bolt installing to torque converter housing.
· 5.5~8.3kgf · m(39.8~60.0lbf · ft)

(4) Radiator hoses

· Distance to insert hose : 60mm(2.36in)

(5) Air cleaner hose

Insert the air cleaner hose securely and fit a clamp.

Distance to insert hose

- Air cleaner hose : 100mm(3.94in)
- Engine end(MHI) : 70mm(2.7in)

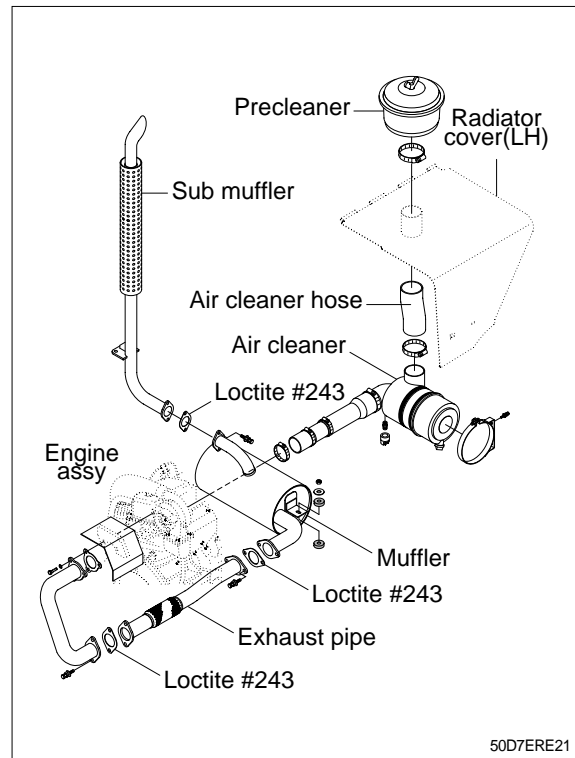

4. STEERING AXLE

1) REMOVAL

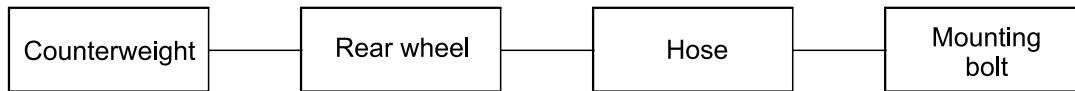

D503RE35

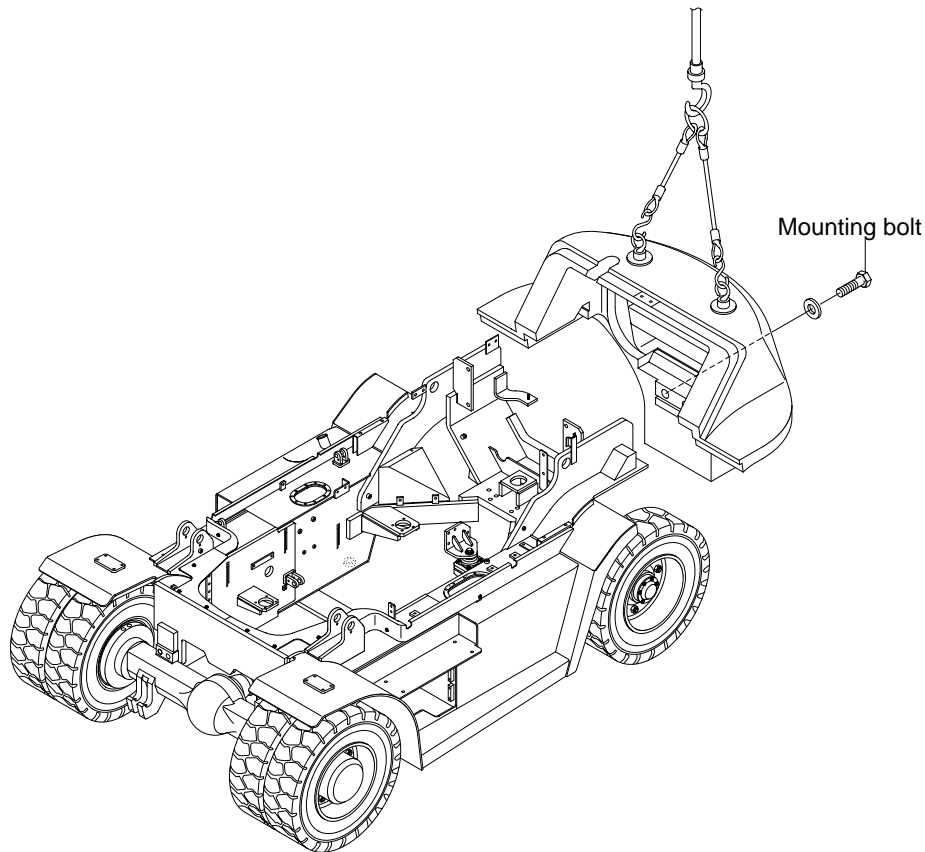

50D7ERE30

(1) Counterweight

Hold the counterweight with hoist bars, and raise it with a crane.

Remove the mounting bolts, raise slightly and move it slowly to rear side.

· Weight of counterweight(standard)

50D-7E : 1,825kg(4,020lb)

60D-7E : 2,490kg(5,490lb)

70D-7E : 3,640kg(8,020lb)

80D-7E : 3,640kg(8,020lb)

(2) Rear wheel

Remove mounting bolt and hub nut with socket wrench and then carefully take out the tire assembly.

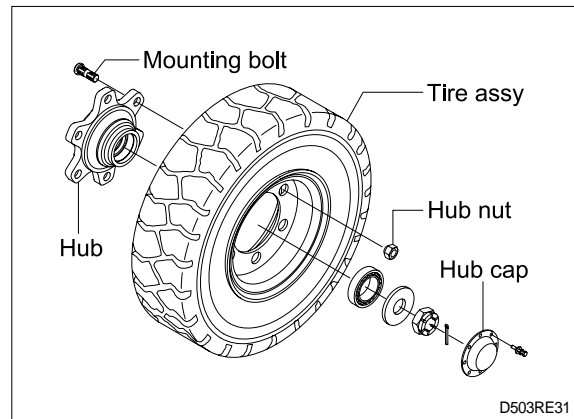

(3) Hose

Disconnect the hoses from steering axle and then drain out oil.

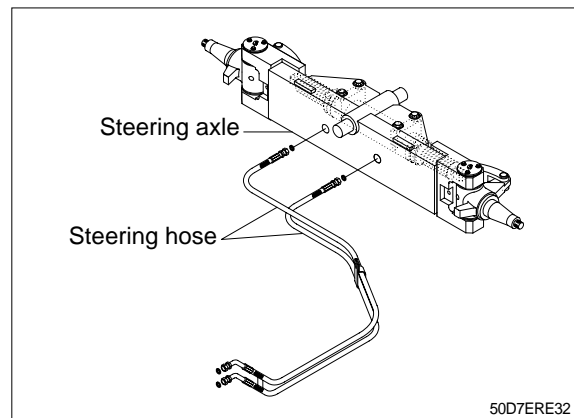

(4) Mounting bolt

Put a block under the steering axle, support on a truck, and raise the frame with a crane. Remove the mounting bolts installing to the frame, and pull out to the rear.

There are shims between the support and steering axle to prevent play.

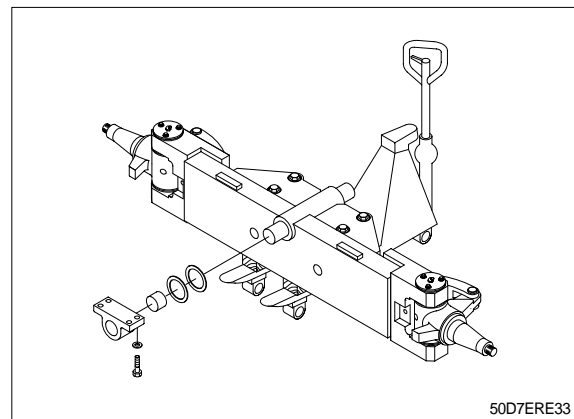

SECTION 3 POWER TRAIN SYSTEM

GROUP 1 STRUCTURE AND OPERATION

1. POWER TRAIN COMPONENT OVERVIEW

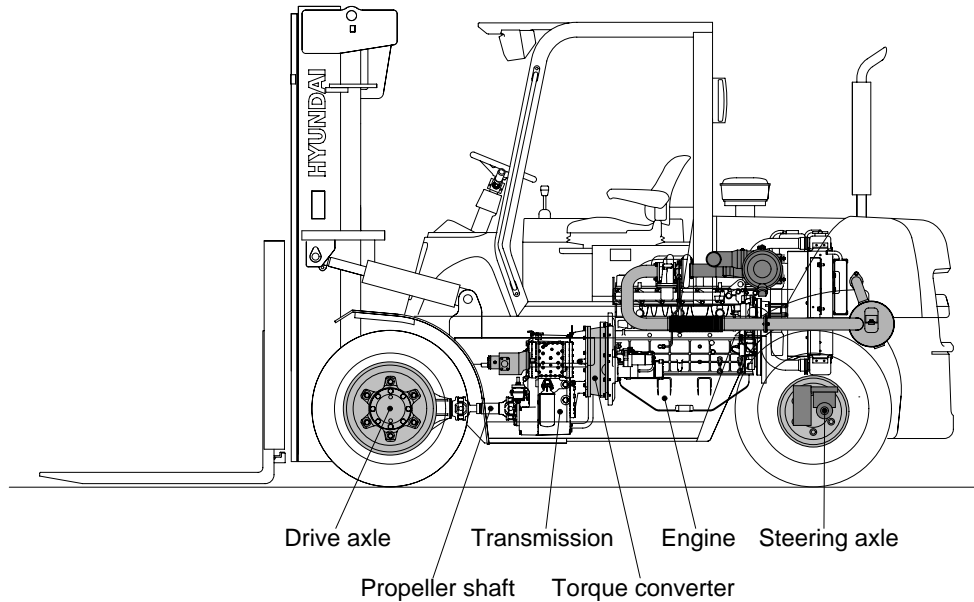

50D7EPT01

The power train consists of the following components :

- Torque converter
- Transmission
- Propeller shaft
- Drive axle

Engine power is transmitted to the transmission through the torque converter.

The transmission is a hydraulically engaged three speed forward, three speed reverse power shift type transmission.

The transmission outputs through universal joints to drive axle assembly.

The power transmitted to front axle drives front wheels.

2. TORQUE CONVERTER

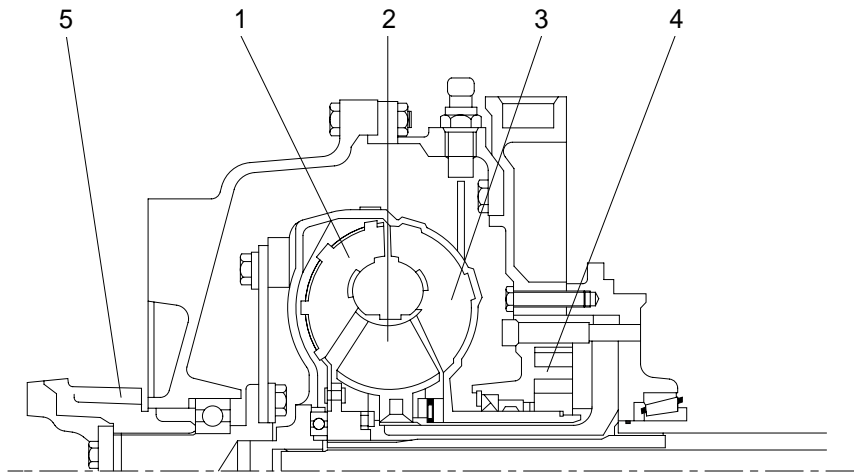

D503TM01

- | | | | | | |
|---|---------|---|-------------------|---|-------------|
| 1 | Turbine | 3 | Pump | 5 | Input shaft |
| 2 | Stator | 4 | Transmission pump | | |

The converter is working according to the Trilok-system, i.e. it assumes at high turbine speed the characteristics, and with it the favorable efficiency of a fluid clutch.

The converter will be defined according to the engine power so that the most favorable operating conditions for each installation case are given.

The Torque converter is composed of 3 main components :
Pump wheel - turbine wheel - stator(Reaction member)

These 3 impeller wheels are arranged in such a ring-shape system that the fluid is streaming through the circuit components in the indicated order.

Pressure oil is constantly streaming out of the transmission pump through the converter. In this way, the converter can fulfill its task to multiply the torque of the engine, and at the same time, the heat created in the converter is dissipated through the escaping oil.

The oil, escaping out of the pump wheel, enters the turbine wheel and is there inverted in the direction of flow.

According to the rate of inversion, the turbine wheel and with it also the output shaft, receive a more or less high reaction moment. The stator(Reaction member), following the turbine, has the task to invert again the oil which is escaping out of the turbine and to deliver it under the suitable discharge direction to the pump wheel.

Due to the inversion, the stator receives a reaction moment.

The relation turbine moment/pump moment is called torque conversion. This is the higher the greater the speed difference of pump wheel and turbine wheel will be.

Therefore, the maximum conversion is created at standing turbine wheel.

With increasing output speed, the torque conversion is decreasing. The adoption of the output speed to a certain required output moment is infinitely variable and automatically achieved by the torque converter.

If the turbine speed is reaching about 80% of the pump speed, the conversion becomes 1.0 i.e. the turbine moment becomes equal to that of the pump moment.

From this point on, the converter is working similar to a fluid clutch.

A stator freewheel serves to improve the efficiency in the upper driving range, it is backing up in the conversion range the moment upon the housing, and is released in the coupling range.

In this way, the stator can rotate freely.

Function of a hydrodynamic torque converter (Schematic view)

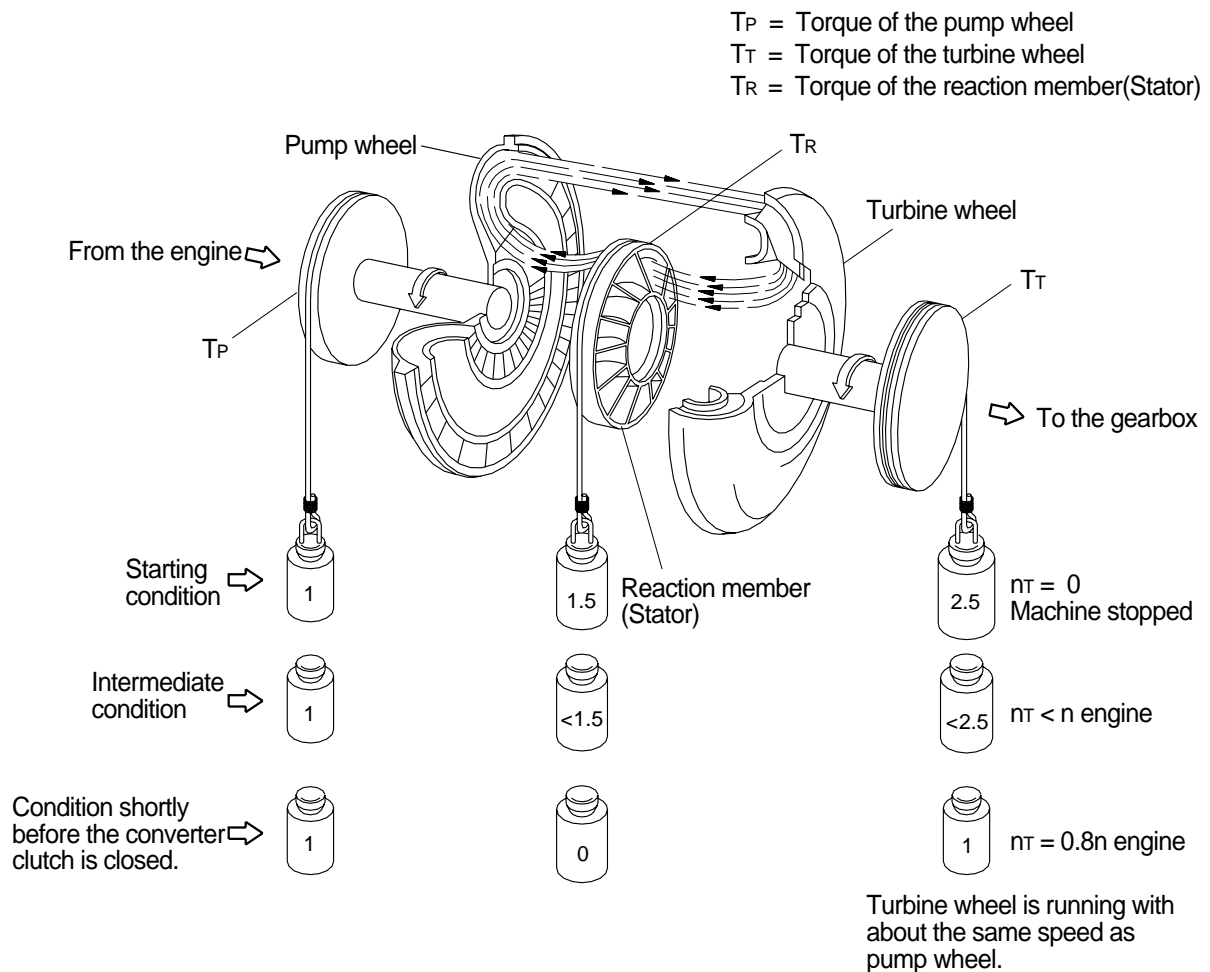

D503TM02

3. TRANSMISSION

1) LAYOUT

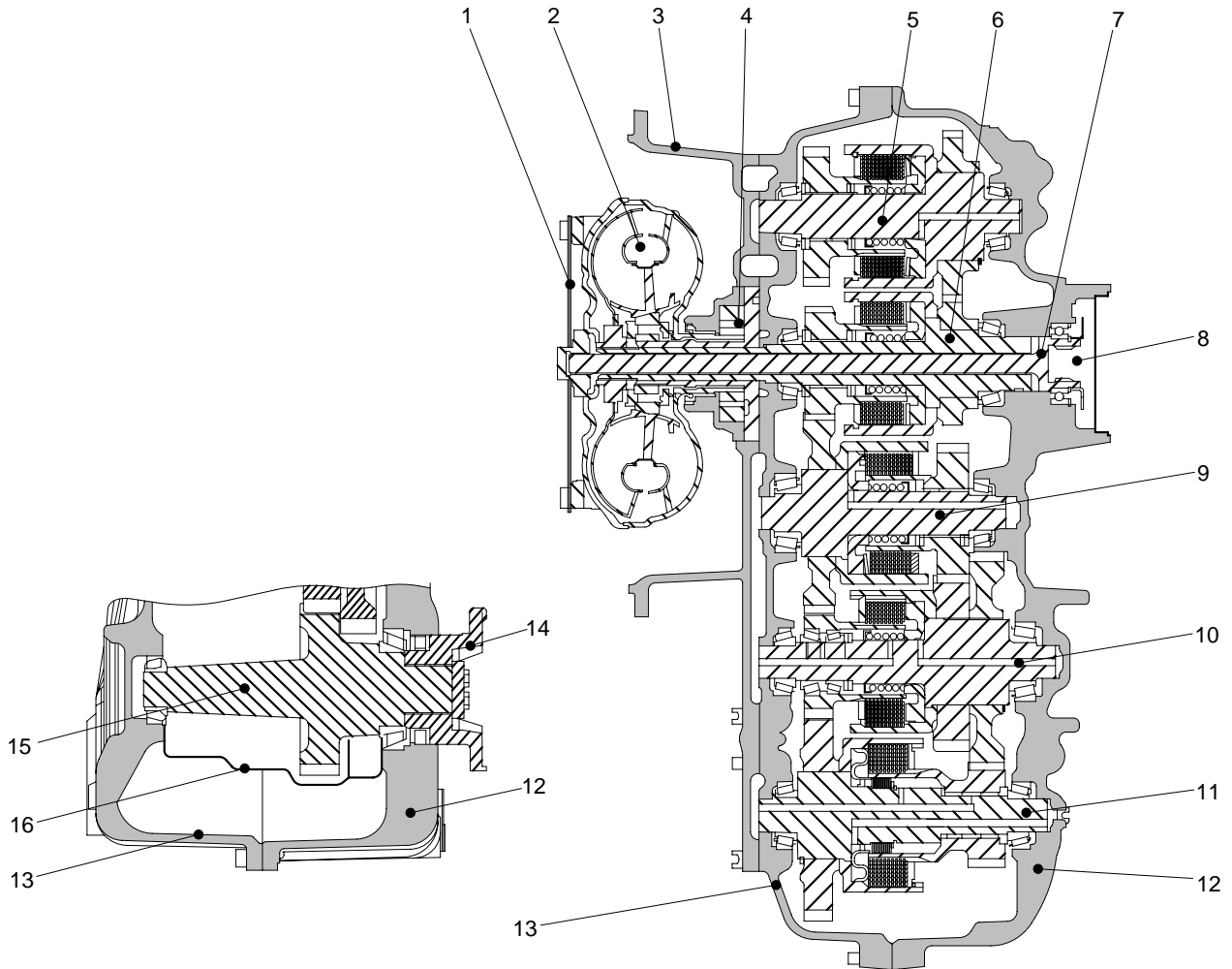

50DS7ETM03

- | | | | | | |
|---|------------------------------|----|--|----|-----------------------------------|
| 1 | Flex plate for direct mount | 7 | Central shaft/input shaft PTO | 12 | Transmission housing - rear part |
| 2 | Converter | 8 | Connection, PTO ; coaxial,
engine-dependent | 13 | Transmission housing - front part |
| 3 | Converter bell housing | 9 | Clutch shaft(KD) | 14 | Output flange |
| 4 | Transmission pump | 10 | Clutch shaft(KE) | 15 | Output shaft |
| 5 | Clutch shaft(KV) | 11 | Clutch shaft(KC) | 16 | Screen sheet |
| 6 | Input shaft/clutch shaft(KR) | | | | |

2) INSTALLATION VIEW

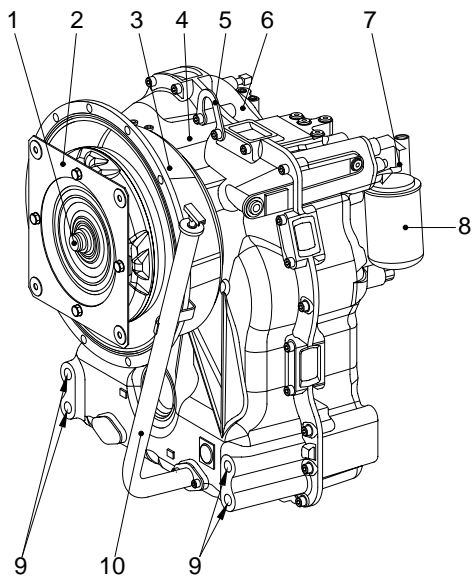

FRONT VIEW

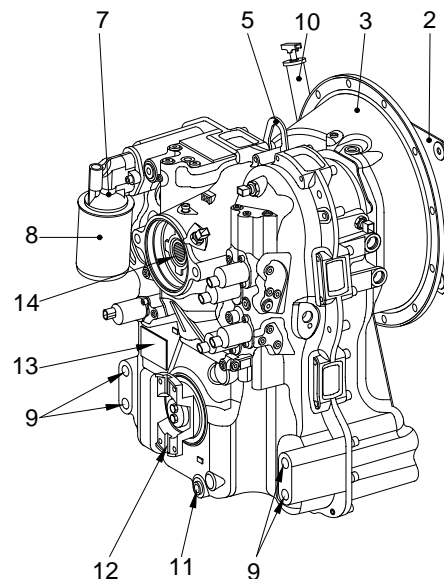

REAR VIEW

50DS7EPT26

- | | | | |
|---|---------------------------------|----|---|
| 1 | Converter | 8 | Filter |
| 2 | Direct mount via flex plate | 9 | Transmission mounting holes M16 × 1.5 |
| 3 | Converter bell housing | 10 | Oil filter tube with oil dipstick |
| 4 | Transmission housing-front part | 11 | Oil drain plug 7/8"14 UNF 2B |
| 5 | Transport bracket | 12 | Output flange MECH 6C |
| 6 | Transmission housing-rear part | 13 | Identification plate |
| 7 | Filter head | 14 | Connection PTO; coaxial, engine-dependent |

3) OPERATION OF TRANSMISSION

(1) Gearbox diagram

The multi-speed reversing transmission in countershaft design is power shiftable by hydraulically actuated multi-disk clutches.

All gears are constantly meshing and carried on antifriction bearings.

The gear wheels, bearings and clutches are cooled and lubricated with oil.

The 3-speed reversing transmission is equipped with 5 multi-disk clutches.

At the shifting, the actual plate pack is compressed by a piston, movable in axial direction, which is pressurized by pressure oil.

A compression spring takes over the pushing task of the piston, thus the release of the plate pack. As to the layout of the transmission as well as the specifications of the closed clutches in the single speeds.

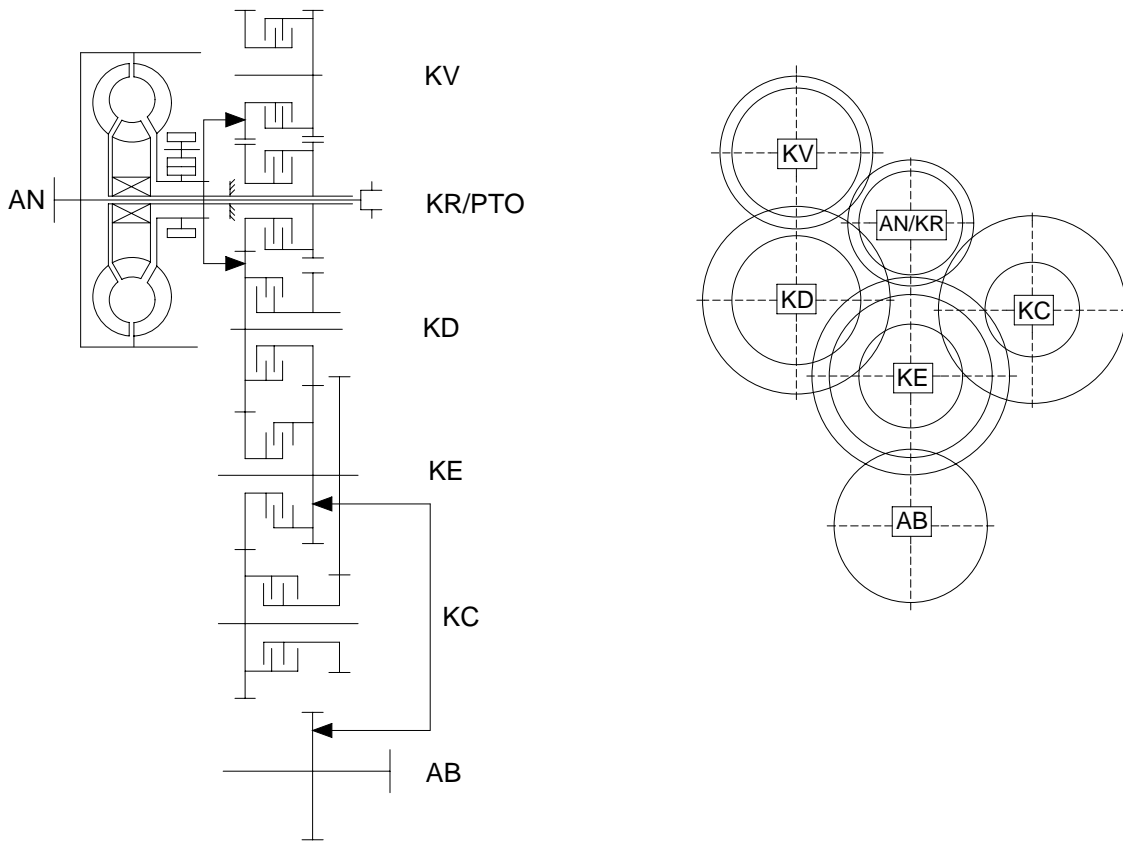

Legend:

- AN = Input
- KV = Clutch forward
- KR = Clutch reverse
- KC = Clutch 1st speed
- KD = Clutch 2nd speed
- KE = Clutch 3rd speed
- PTO = Power take-off
- AB = Output

Diagram Clutches

Driving direction	Speed	Clutch
Forward	1	KV/KC
	2	KV/KD
	3	KV/KE
Reverse	1	KR/KC
	2	KR/KD
	3	KR/KE

50DS7EPT32

(2) Forward

In forward, forward clutch and 1st, 2nd, 3rd clutch are engaged.

Forward clutch and 1st, 2nd, 3rd clutch are actuated by the hydraulic pressure applied to the clutch piston.

Transmission diagram

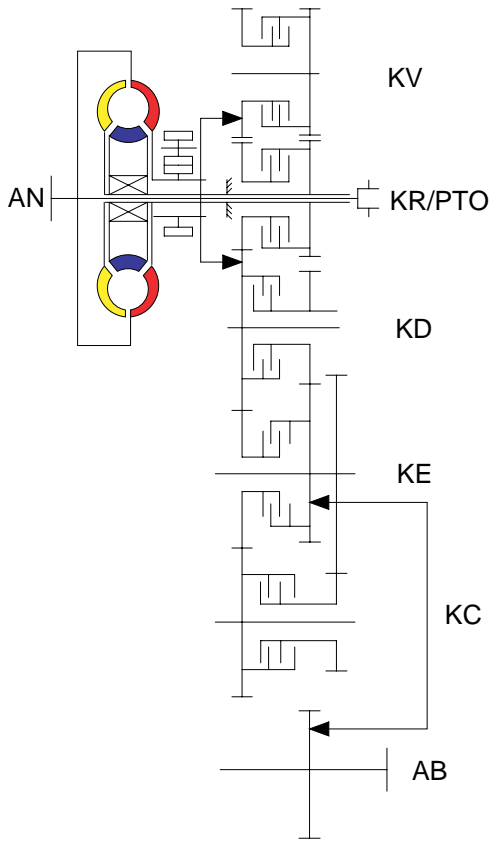

1st gear forward

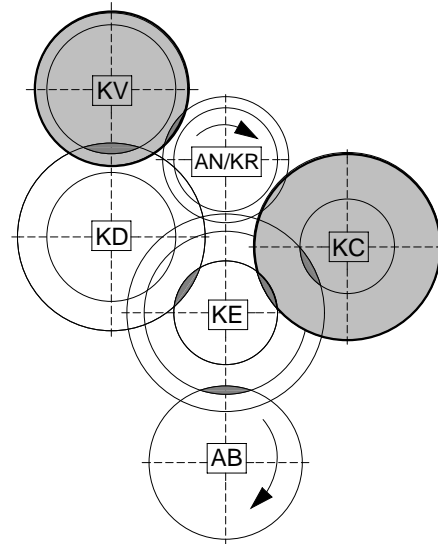

Legend:

- AN = Input
- KV = Clutch forward
- KR = Clutch reverse
- KC = Clutch 1st speed
- KD = Clutch 2nd speed
- KE = Clutch 3rd speed
- PTO = Power take-off
- AB = Output

2nd gear forward

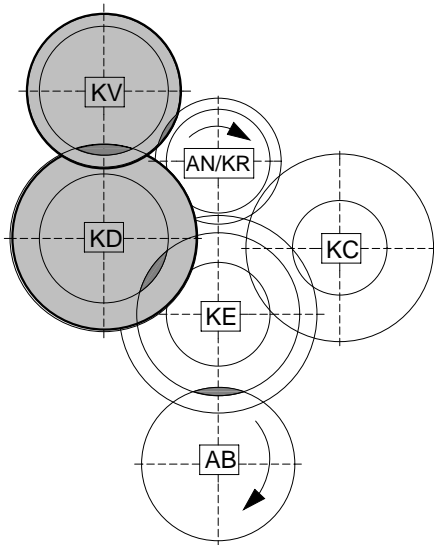

3rd gear forward

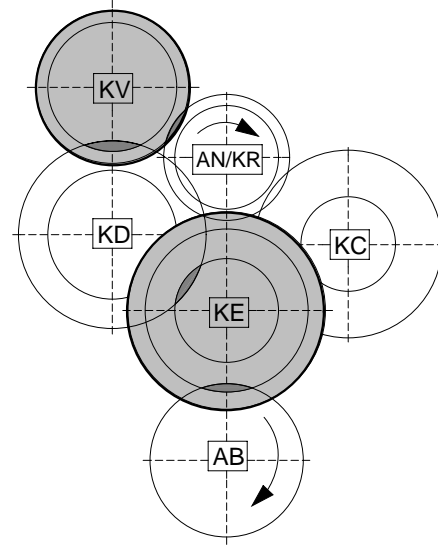

(3) Reverse

In reserve, reserve clutch and 1st, 2nd, 3rd clutch are engaged.

Reverse clutch and 1st, 2nd, 3rd are actuated by the hydraulic pressure applied to the clutch piston.

Transmission diagram

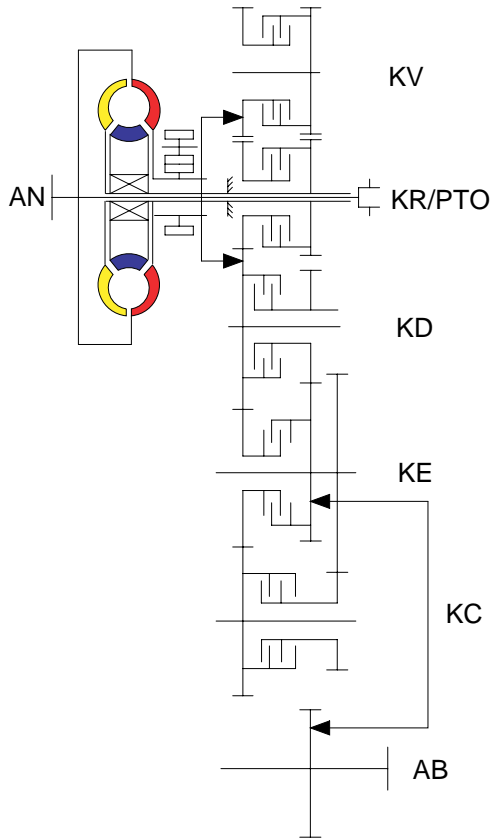

1st gear reverse

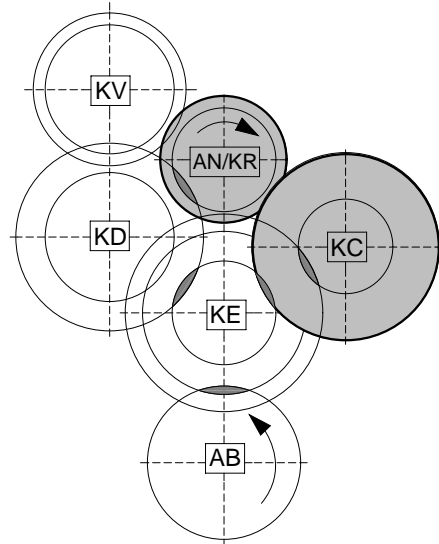

Legend:

- AN = Input
- KV = Clutch forward
- KR = Clutch reverse
- KC = Clutch 1st speed
- KD = Clutch 2nd speed
- KE = Clutch 3rd speed
- PTO = Power take-off
- AB = Output

2nd gear reverse

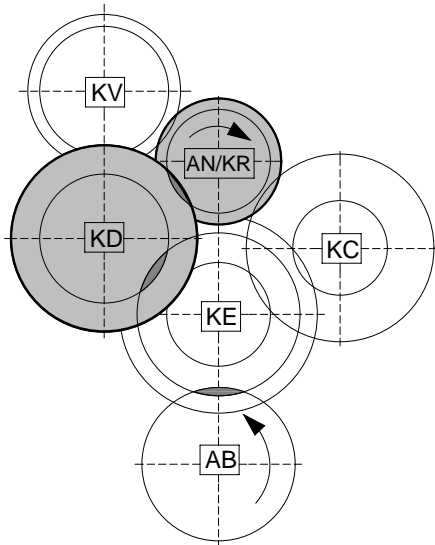

3rd gear reverse

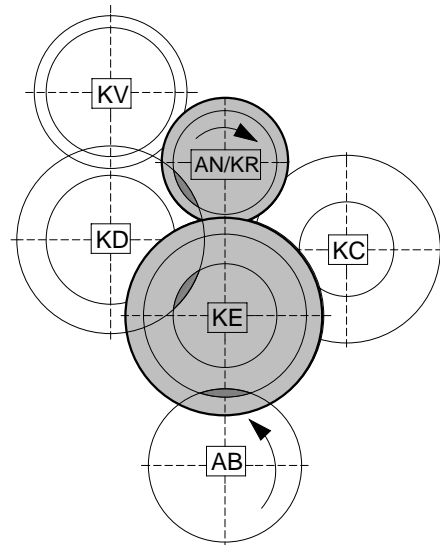

4) TRANSMISSION CONTROL

Transmission control see measuring points and oil circuit diagram see page 3-10.

The transmission pump which is necessary for the oil supply of the converter and for the transmission control is located within the transmission on the engine-dependent input shaft.

The pump feed rate is $Q=45 \text{ l /min}$, at $n_{\text{engine}}=1500\text{min}^{-1}$

This pump is sucking the oil out of the oil sump via the coarse filter, and delivers it to the main pressure valve via the fine filter.

The 5 clutches of the transmission are controlled via the 5 proportional valves Y1 to Y5.

The direct proportional control with separate pressure modulation for each clutch controls the pressures towards the clutches which are involved in the gear change.

This allows a hydraulic overlapping of the clutches to be engaged and disengaged.

The pressure modulation to the respective clutch is controlled by cup springs and proportional valves in the package.

This creates spontaneous shifting without tractive effort interruption.

The following criteria are considered during the shifting operation:

- RPM of engine, turbine, gear chain and output
- Transmission temperature
- Shifting mode(upshifting, downshifting, reverse shifting and gear engagement out of neutral)
- Load condition(full and partial load, drive, coast, including consideration of load reversals during shifting)
- Electronic inching

The main pressure valve limits the max, control pressure to $16+3 \text{ bar}$ and release the main stream towards the converter-and lubrication circuit.

The converter inlet incorporates a converter safety valve which protects the converter from high internal pressure(opening pressure $11+2 \text{ bar}$).

Within the converter, the oil serves for transmitting the power according to the well-known hydrodynamic principle(see Chapter torque converter page 3-2)

To avoid cavitation, the converter must always be completely filled with oil.

• Hydraulic circuit

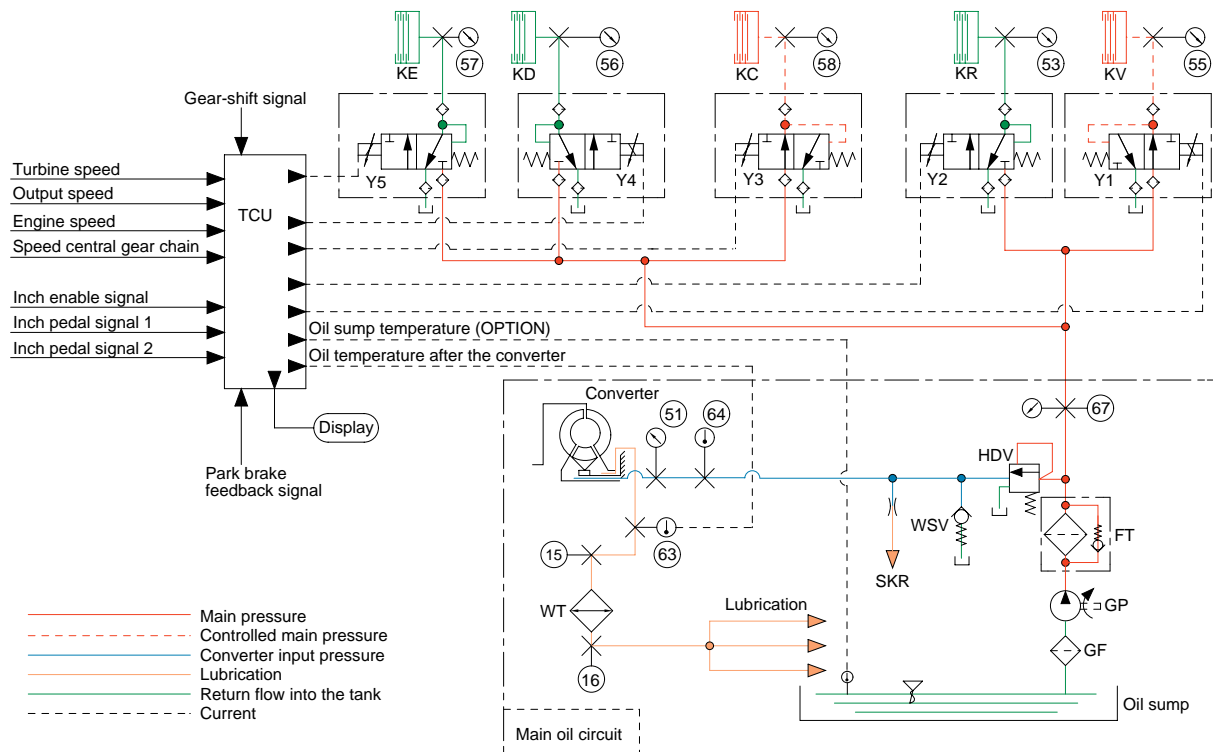

50DS7EPT31

Driving direction	Gear	Proportional valve under current						Engaged clutches	
		Y1	Y2	Y3	Y4	Y5	N		
Forward	1	●		●				KV	KC
	2	●			●			KV	KD
	3	●				●		KV	KE
Reverse	1		●	●				KR	KC
	2		●		●			KR	KD
	3		●			●		KR	KE
Engaged clutch		KV	KR	KC	KD	KE			
Curr. No. of meas. points		55	53	58	56	57			

- GF Coarse filter
- GP Transmission pump
- FT Filter
- HVD Main pressure valve, 16+3bar
- WSV Converter safety valve, 11+2bar
- SKR Lubrication of KR clutch
- WT Heat exchanger
- Y1 Proportional valve, clutch KV
- Y2 Proportional valve, clutch KR
- Y3 Proportional valve, clutch KC
- Y4 Proportional valve, clutch KD
- Y5 Proportional valve, clutch KE
- KV KV clutch, forward
- KR KR clutch, reverse
- KC KC clutch, 1st gear
- KD KD clutch, 2nd gear
- KE KE clutch, 3rd gear
- TCU Transmission control unit

5) GEAR SELECTOR(DW-3)

The gear selector is designed for the mounting on the steering column left side. By a rotative motion, the positions(speeds) 1 to 3 are selected by tilting the lever, the driving direction(Forward (F) - Neutral(N) - Reverse(R)).

For the protection from unintended start off, a neutral interlock is installed :

Position «N" - Controller lever blocked in this position

Position «D" - Driving

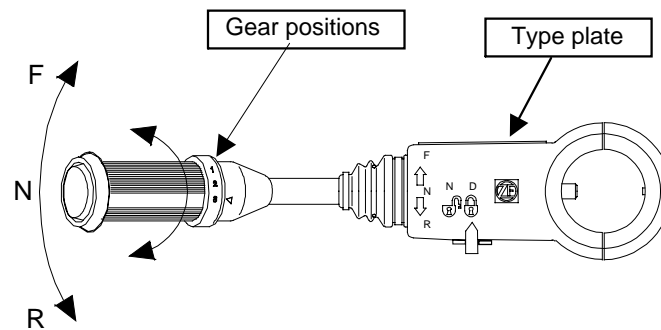

D507PT12

Gear selector(DW-3)

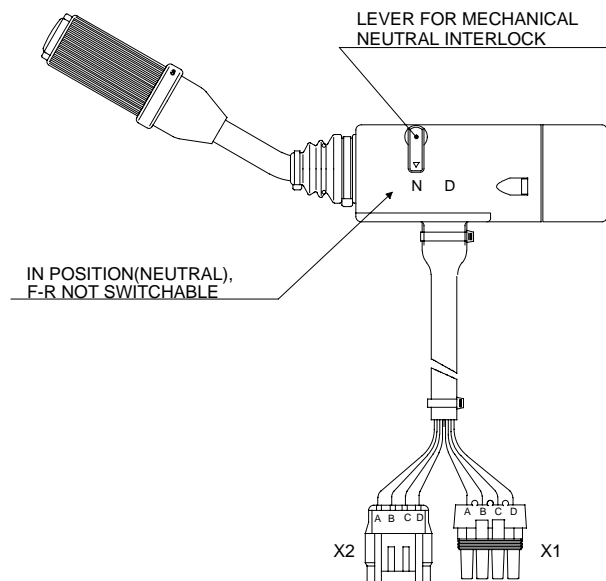

CODING GEAR SELECTOR

SPEED		OUTPUT									KD	
		FORWARD			REVERSE			NEUTRAL				
		1	2	3	1	2	3	1	2	3		
AD1	B1	●			●			●				
AD2	B2			●			●				●	
AD3	B3	●	●	●	●	●	●	●	●	●		
AD4	V	●	●	●								
AD5	R				●	●	●					
AD6	AS							●	●	●		
AD7												●

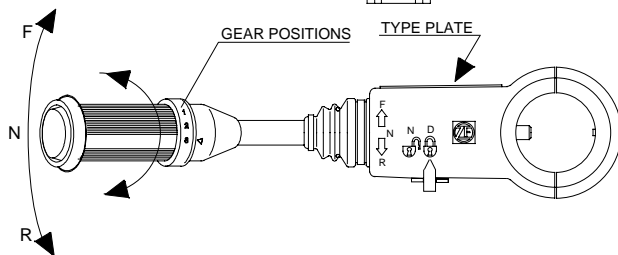

- F = Forward
- N = Neutral
- R = Reverse
- D = Mechanical neutral interlock
- 1 = 1st speed
- 2 = 2nd speed
- 3 = 3rd speed

CIRCUIT DIAGRAM SELECTOR

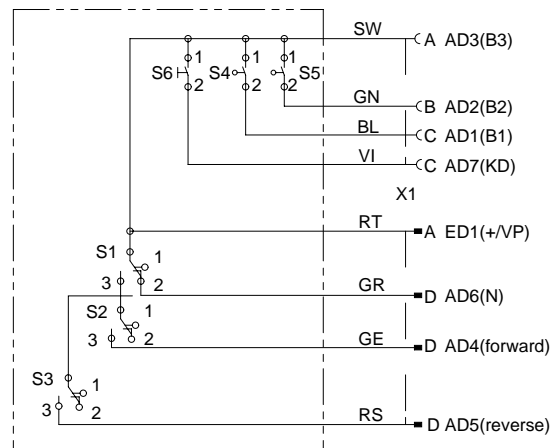

CIRCUIT DIAGRAM SELECTOR

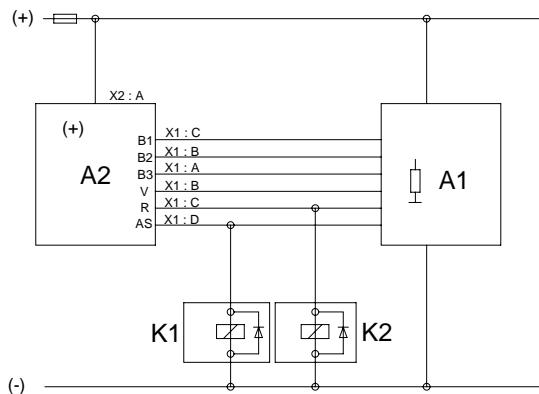

- K1 = Relay starter interlock
- K2 = Relay reverse lights
- A1 = TCU(Transmission Control Unit)
- A2 = Gear selector

6) TRANSMISSION ERROR DISPLAY



(1) Function

The display can be used with the gear selector. It indicates speed and driving direction as well as the activated inching.

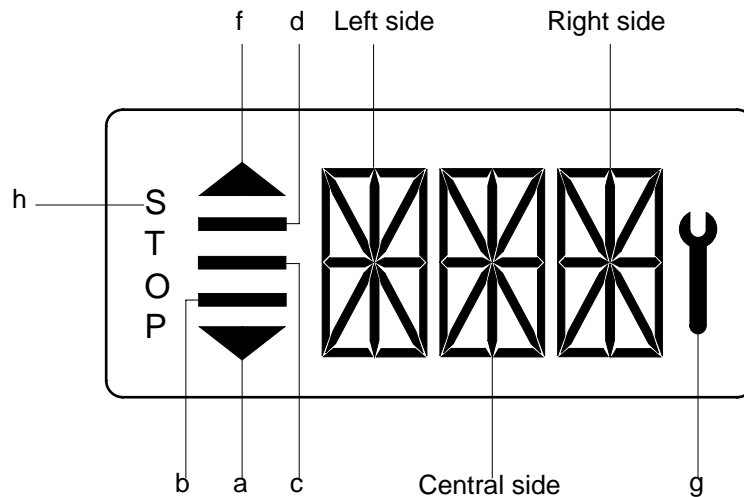
When driving in the automatic mode, a bar indicator gives additionally also information about the selected driving range; The automatic range is symbolized by arrows above and below the bar indicator. In case of possible errors in the system, a wrench appears on the display, combined with indication of the error number. Also sporadically occurring errors can be indicated.

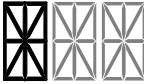

D507CD33

1	Bars	a, f	Automatic range(up and down shifting)
		b, c, d,	Preselected gear
2	Left side		For the moment still without function
3	Central and Right side		On the two alphanumeric 16-segment display, the electric control unit issues the actual state of gear and driving direction. Besides, a two digit error code will be indicated via these two segment
4	Spanner	g	Electronic control unit recognized an error, is flashing
5	Letters STOP	h	Immediate stop is required(At the moment not activated)

(2) Abbreviations

- OC : Open circuit
- SC : Short circuit
- OP mode : Operating mode
- TCU : Transmission control unit
- EEC : Electronic engine controller
- PTO : Power take off

(3) Display during operation

Symbol	Meaning	Remarks
F, N, R 1, 2, 3	Actual gear and direction Central side shows actual gear Right side shows actual direction	
NN (Central and right side)	Not neutral, waiting for neutral after power up or a reverse fault	To engage a gear, first move shift selector to neutral position and again to F to R position
1 bar	Manual mode 1st gear	
2 bar	Manual mode 2nd gear	
3 bar	Manual mode 3rd gear	
3bars and 2 arrows	Automatic mode	a, f
□ □	Transmission neutral	Cold start phase
Spanner flashing	At least on fault active	Select neutral to get fault code displayed
WT	Warning torque converter temperature	Changes between actual gear/direction while driving, in neutral only displayed if no fault is detected(spanner)
WS	Warning sump temperature	Changes between actual gear/direction while driving, in neutral only displayed if no fault is detected(spanner)
WE	Warning high engine speed	Changes between actual gear/direction while driving, in neutral only displayed if no fault is detected(spanner)
PN	Direction F or R selected while parking brake engaged	Transmission in neutral until parking brake is released. ※ Machine starts to move after release of parking brake.
F or R flashing	Direction F or R selected while turbine speed is to high	※ Gear will engage when turbine speed drops
EE flashing (central and right side)	No communication with display	

(4) Display during AEB-Mode

Symbol	Meaning	Remarks
PL	AEB-Starter is plugged at the diagnostic plug	
ST	AEB-Starter-button is pressed	
KA.....KE KV, KR	Calibrating clutch KC..KE, KV or KR resp.	KC, KD for 2 gear transmission KC, KD, KE for 3 gear transmission
_and Kx	Wait for start, initialization of clutch Kx, x : C, D, E, V, R	
≡and Kx	Fast fill time determination of clutch Kx	
=and Kx	Compensating pressure determination of clutch Kx	
OK	Calibration for all clutches finished	Transmission stays in neutral, you have to restart the TCU(ignition off/on) after removing AEB-Starter
STOP	AEB canceled(activation stopped)	Transmission stays in neutral, you have to restart the TCU(ignition off/on)
STOP and Kx	AEB stopped, clutch Kx can't be calibrated	Transmission stays in neutral, you have to restart the TCU(ignition off/on)
Spanner and Kx	Kx couldn't be calibrated, AEB finished	Transmission stays in neutral, you have to restart the TCU(ignition off/on)
△ E	Engine speed too low → raise engine speed	
▽ E	Engine speed too high → lower engine speed	
△ T	Transmission oil temperature too low→heat up transmission	
▽ T	Transmission oil temperature too high→cool down transmission	
FT	Transmission temperature not in defined range during calibration	Transmission stays in neutral, you have to restart the TCU(ignition off/on)
FB	Operating mode not NORMAL or transmission temperature sensor defective or storing of Calibrated values to EEPROM-has failed.	Transmission stays in neutral, you have to restart the TCU(ignition off/on)
FO	Outputspeed_not_zero	Transmission stays in neutral, you have to restart the TCU(ignition off/on)
FN	Shift lever not in Neutral position	Transmission stays in neutral, you have to restart the TCU(ignition off/on)
FP	Parkbrake_not_applied	Transmission stays in neutral, you have to restart the TCU(ignition off/on)
STOP	AEB-Starter was used incorrect or is defective. Wrong device or wrong cable used.	Transmission stays in neutral, you have to restart the TCU(ignition off/on)

(5) Definition of the error codes

① Introduction

The error codes consists of two hexadecimal numbers.

The first number shows the type of signal, the second number shows signal and the type of the error.

② Description of error codes

First No.	Meaning of number
1 hex	Digital input signals
2 hex	Analog input signals
3 hex	Speed signals
4 hex	Speed signals
7 hex	Analog current output signals
8 hex	Analog current output signals
9 hex	Digital output signals
A hex	Digital output signals
B hex	Clutch errors
D hex	Power supply
E hex	High speed signals
F hex	General errors

③ List of error codes

Number	Meaning of error code
11 hex	Logical error at gear range signal
12 hex	Logical error at direction select signal
21 hex	Short circuit to battery voltage at clutch cutoff input
22 hex	Short circuit to ground or open circuit at clutch cutoff input
25 hex	Short circuit to battery voltage or open circuit at temperature sensor input
26 hex	Short circuit to ground at temperature sensor input
31 hex	Short circuit to battery voltage at engine speed input
32 hex	Short circuit to ground or open circuit at engine speed input
33 hex	Logical error at engine speed input
34 hex	Short circuit to battery voltage at turbine speed input
35 hex	Short circuit to ground or open circuit at turbine speed input
36 hex	Logical error at turbine speed input
37 hex	Short circuit to battery voltage at internal speed input
38 hex	Short circuit to ground or open circuit at internal speed input
39 hex	Logical error at internal speed input

Number	Meaning of error code
3A hex	Short circuit to battery voltage or open circuit at output speed input
3B hex	Short circuit to ground or open circuit at output speed input
3C hex	Logical error at output speed input
71 hex	Short circuit to battery voltage at clutch KC
72 hex	Short circuit to ground at clutch KC
73 hex	Open circuit at clutch KC
74 hex	Short circuit to battery voltage at clutch KD
75 hex	Short circuit to ground at clutch KD
76 hex	Open circuit at clutch KD
77 hex	Short circuit to battery voltage at clutch KE
78 hex	Short circuit to ground at clutch KE
79 hex	Open circuit at clutch KE
84 hex	Short circuit to battery voltage at clutch KV
85 hex	Short circuit to ground at clutch KV
86 hex	Open circuit at clutch KV
87 hex	Short circuit to battery voltage at clutch KR
88 hex	Short circuit to ground at clutch KR
89 hex	Open circuit at clutch KR
91 hex	Short circuit to ground at relay reverse warning alarm
92 hex	Short circuit to battery voltage at relay reverse warning alarm
93 hex	Open circuit at relay reverse warning alarm
94 hex	Short circuit to ground at relay starter interlock
95 hex	Short circuit to battery voltage at relay starter interlock
96 hex	Open circuit at relay starter interlock
97 hex	Short circuit to ground at park brake solenoid
98 hex	Short circuit to battery voltage at park brake solenoid
99 hex	Open circuit at park brake solenoid

Number	Meaning of error code
B1 hex	Slippage at clutch KC
B2 hex	Slippage at clutch KD
B3 hex	Slippage at clutch KE
B5 hex	Slippage at clutch KV
B6 hex	Slippage at clutch KR
D1 hex	Short circuit to battery voltage at power supply for sensors
D2 hex	Short circuit to ground at power supply for sensors
D3 hex	Low voltage at battery
D4 hex	High voltage at battery
D5 hex	Error at valve power supply 1
D6 hex	Error at valve power supply 2
E5 hex	Communication failure on devicenet
F1 hex	General EEPROM fault
F2 hex	Configuration lost
F3 hex	Application error

6) ELECTRONIC CONTROL FOR POWER TRANSMISSION

(1) Description of the basic functions

The powershift transmission 3 WG-94 EC of series WG-90 is equipped with the electronic transmission control EST-65 specially developed for this purpose.

The system process the driver command according to the following criteria:

- Gear determination depending on driving speed and load condition.
- If required, protection against operating errors is possible via electronic protection (programming)
- Protection against overspeeding(on the basis of engine and turbine speed)
- Pressure cut-off possible(vehicle-specific, only after coordination with ZF)
- Switch-over possibility for automatic / manual operation
- Downshifting functions possible
- Electronic inching

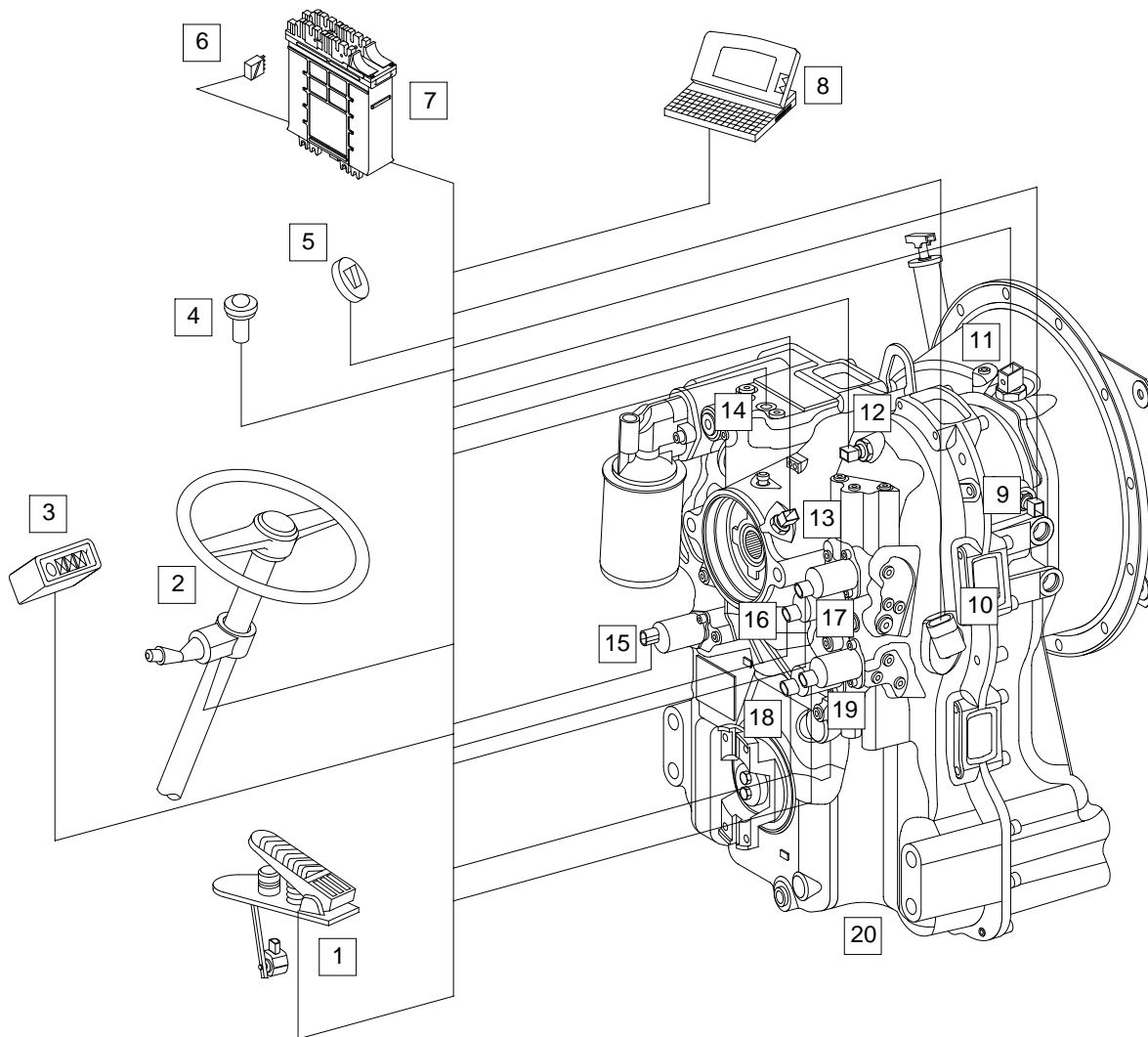

50DS7EPT17

- | | | | |
|----|--|----|--|
| 1 | Inching pedal | 11 | Temperature measuring point after the converter (No. 63) |
| 2 | Gear selector | 12 | Inductive sensor - turbine speed |
| 3 | Display | 13 | Inductive sensor - engine speed |
| 4 | Optical warning | 14 | Temperature measuring point for the converter (No. 64) |
| 5 | Switch for driving program
Manual/Automatic | 15 | Proportional valve Y3 - KC clutch |
| 6 | CAN connection | 16 | Proportional valve Y2 - KR clutch |
| 7 | TCU | 17 | Proportional valve Y1 - KV clutch |
| 8 | Diagnostic Laptop with ZF diagnostic
system Testman/Pro | 18 | Proportional valve Y5 - KE clutch |
| 9 | Inductive sensor - speed of central gear chain | 19 | Proportional valve Y4 - KD clutch |
| 10 | Speed sensor - output | 20 | Ergopower transmission 3 WG-94 EC |

(2) Inching device

This function is especially suitable for lift trucks. Without modifying the engine speed, it allows a continuously variable reduction of the driving speed to such a level that operation at a very low speed is possible. In this way, the driver can move the vehicle to a certain position with high accuracy.

At the same time, a large part of the engine power is available for driving the hydraulic lifting system, due to the high engine speed.

The electrical inching is operated via a separate inching pedal fitted with an angle-of-rotation sensor.

By means of the proportional valve technology, the TCU controls the pressure in the driving direction clutch in such a way that the driving speed is adjusted in accordance with the position of the inching angle-of-rotation sensor. Clutch overloading is prevented by the electronic protection.

- ※ After each readjustment of the inching linkage, the IPK(Inch Pedal Calibration-Inch Sensor Calibration) must be carried out.

During the inching calibration mode, the position of the inching pedal in neutral position and at full actuation is determined by the calibration process and stored in theTCU.

- ※ The inching function does not become active until successful completion of AEB and IPK start.

4. TRANSMISSION MEASURING POINTS AND CONNECTIONS

The measurement have to be carried out with hot transmission(about 80~95° C)

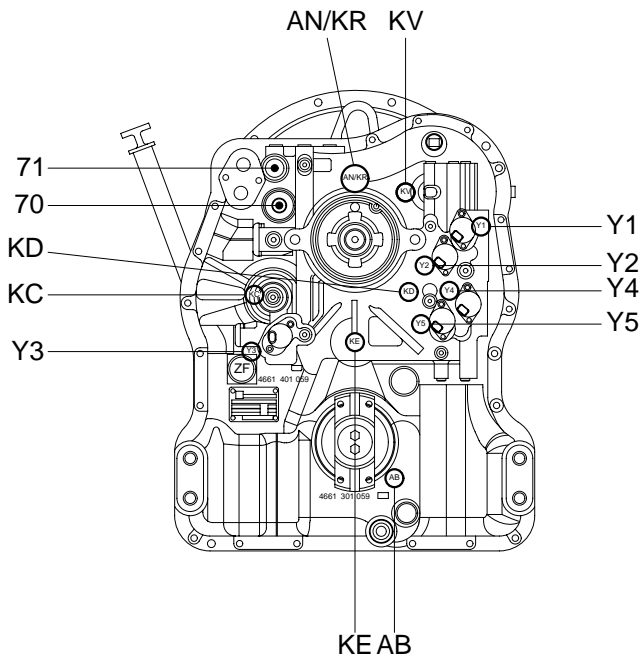
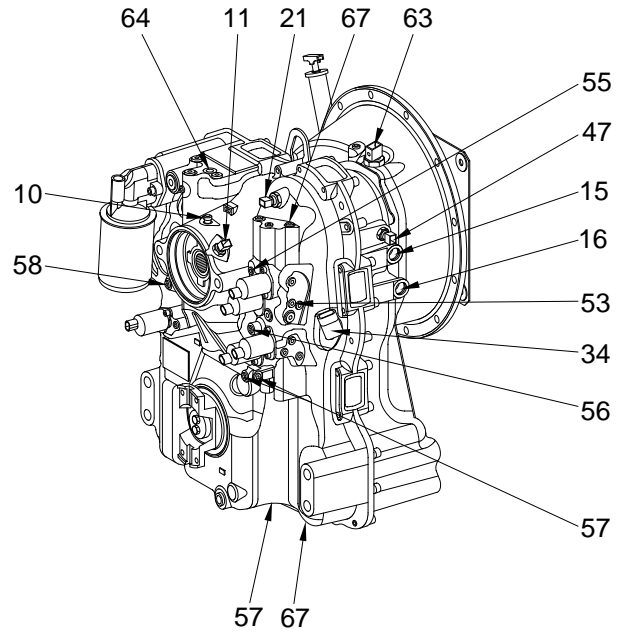
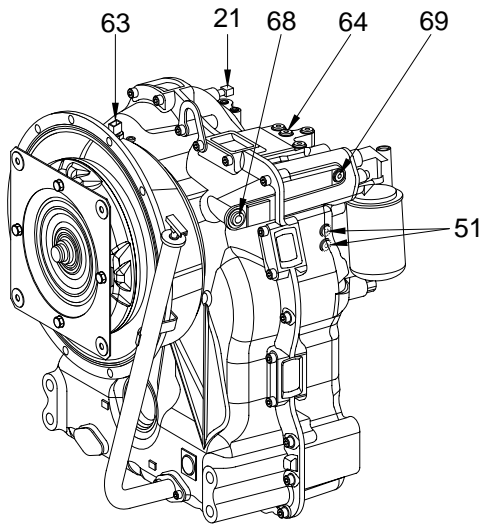

50DS7ETM04

1) Measuring points for pressure oil and temperature

Port	Description	Size
51	Before the converter - opening pressure 11 + 2 bar	M10x1
53	Reverse clutch KR 16 + 3 bar	M10x1
55	Forward clutch KV 16 + 3 bar	M10x1
56	Clutch KD 16 + 3 bar	M10x1
57	Clutch KE 16 + 3 bar	M10x1
58	Clutch KC 16 + 3 bar	M10x1
63	Temperature after the converter 100° C ;short-term 120° C	M14x1.5
64	Temperature sensor	M12x1.5
67	System pressure 16 + 3 bar	M10x1

2) Valves and connections

Port	Description	Size
10	Breather	M10x1
15	Connection towards heat exchange	7/8" 14 UNF
16	Connection from heat exchanger	7/8" 14 UNF
68	Connection after fine filter	9/6-18 UNF-2B
69	Connection before fine filter	7/8" 14 UN 2A
70	Converter safety valve(WSV)	
71	Main pressure valve(HDV)	

3) Inductive transmitters and speed sensor

Port	Description	Size
11	Inductive transmitter n Engine	M18x1.5
21	Inductive transmitter n Turbine	M18x1.5
34	Speed sensor n Output	-
47	Inductive transmitter n Central gear train	M18x1.5

5. DIFFERENTIAL CARRIER ASSEMBLY

1) STRUCTURE

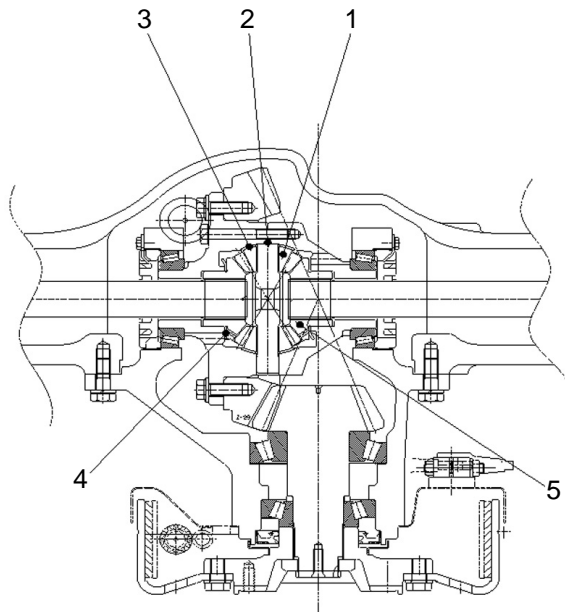

50D7EAX02

No	Item	Unit	Specification
1	Differential pinion gear inner diameter	mm(in)	20.000 - 20.021(0.787~0.788)
2	Spider outer diameter	mm(in)	19.959 - 19.980(0.786~0.787)
3	Pinion gear washer	mm(in)	1.92 - 2.08(0.076~0.082)
4	Side gear washer	mm(in)	1.95 - 2.05(0.077~0.081)
5	Side gear	-	-

2) OPERATION

Differential transmits the power from the transmission to drive wheel.

Differential is composed of 4 pinions(1), 2 side gears(5) and 1 spider(2).

The spider is meshed vertically between 4 pinions(1) and 2 side gear(5), so the engagement become a right angle.

6. DRIVE AXLE

1) STRUCTURE

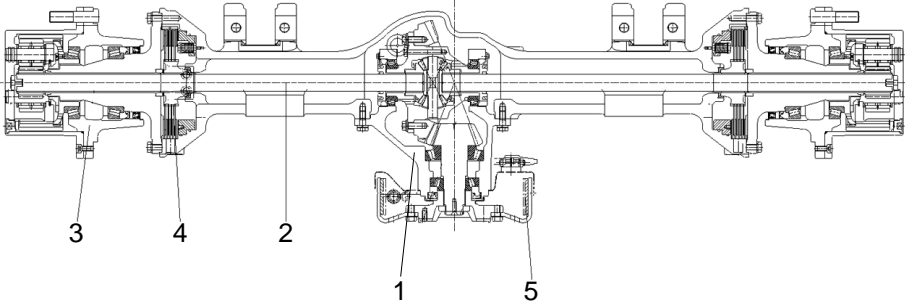

50D7EAX01

- | | | | | | |
|---|----------------------------|---|-------------|---|---------------|
| 1 | Differential carrier ass'y | 3 | Drive wheel | 5 | Parking brake |
| 2 | Drive shaft | 4 | Disc brake | | |

OPERATION

The drive axle is composed of differential carrier ass'y (1), drive shaft (2), and drive wheel (3).

The power is transmitted from the engine fly wheel to the transmission.

The power of transmission is transmitted to the spiral bevel gear through the output gear of the transmission.

Then the power of differential is transmitted to the wheel through the drive shaft.

2) DRIVE AXLE

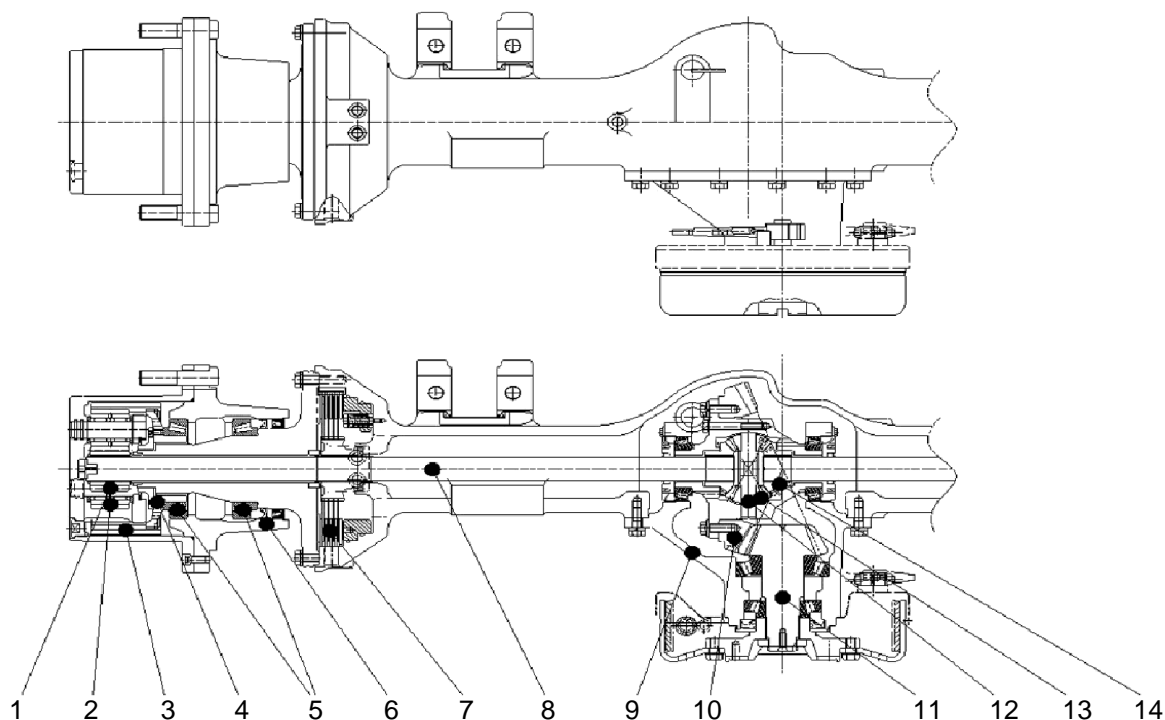

50D7EAX03

- | | | | | | |
|---|--------------------|----|---------------------------|----|--------------------------|
| 1 | Sun gear | 6 | Hub assy | 11 | Pinion shaft |
| 2 | Planetary gear | 7 | Disk brake | 12 | Spider |
| 3 | Inner gear | 8 | Drive shaft | 13 | Differential pinion gear |
| 4 | Inner gear carrier | 9 | Differential carrier assy | 14 | Differential side gear |
| 5 | Tapered bearing | 10 | Ring gear | | |

OPERATION

Drive axle which consists of differential carrier assembly (9), drive shaft (8) and hub assembly (6) transmits the drive force from transmission to the wheels.

Pinion shaft (11) is connected to transmission output through universal joint.

The power of transmission is transmitted to differential which consists of pinion shaft (11) and ring gear (10) and the differential rotates the drive shaft (8).

Side gear (14) and drive shaft (8) are connected with spline and the drive shaft (8) connect to planetary gear (2), inner hub (6) and finally drive wheels.

3) DRIVE AXLE TIGHTENING TORQUE

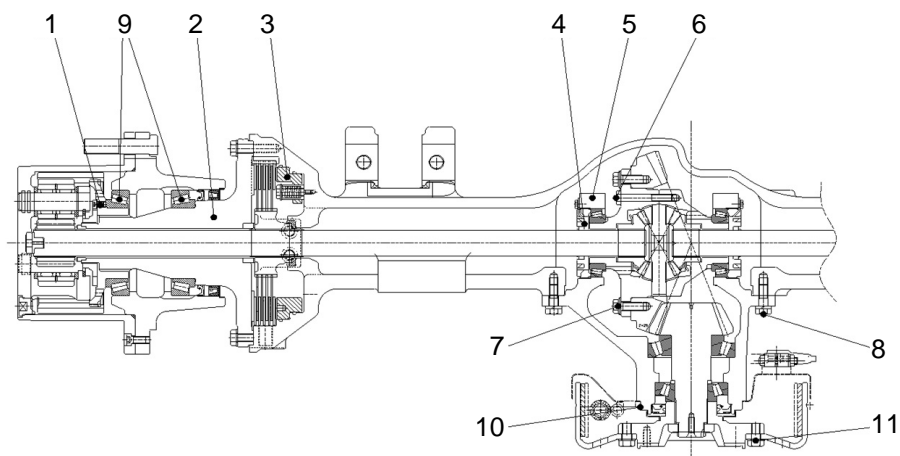

50D7EAX04

No	Item	Specification
1	Inner carrier	$2.2 \pm 0.3 \text{kgf} \cdot \text{m}$ ($15.9 \pm 2.2 \text{lb} \cdot \text{ft}$)
2	Spindle	$12 \pm 0.5 \text{kgf} \cdot \text{m}$ ($86.8 \pm 3.6 \text{lb} \cdot \text{ft}$)
3	Service piston	$1.5 \pm 0.1 \text{kgf} \cdot \text{m}$ ($10.8 \pm 0.7 \text{lb} \cdot \text{ft}$)
4	Adjuster nut	$1.0 \pm 0.2 \text{kgf} \cdot \text{m}$ ($7.2 \pm 1.4 \text{lb} \cdot \text{ft}$)
5	Differential cap	$16 \pm 0.5 \text{kgf} \cdot \text{m}$ ($116 \pm 3.6 \text{lb} \cdot \text{ft}$)
6	Differential case	$6.0 \pm 0.5 \text{kgf} \cdot \text{m}$ ($43.4 \pm 3.6 \text{lb} \cdot \text{ft}$)
7	Ring gear	$13.5 \pm 0.5 \text{kgf} \cdot \text{m}$ ($97.6 \pm 3.6 \text{lb} \cdot \text{ft}$)
8	Differential carrier assembly	$18.0 \pm 0.5 \text{kgf} \cdot \text{m}$ ($130 \pm 3.6 \text{lb} \cdot \text{ft}$)
9	Wheel hub rolling resistant	$3.0 \pm 0.3 \text{kgf} \cdot \text{m}$ ($21.7 \pm 2.2 \text{lb} \cdot \text{ft}$)
10	Parking brake	$20.0 \pm 0.9 \text{kgf} \cdot \text{m}$ ($144.7 \pm 6.5 \text{lb} \cdot \text{ft}$)
11	Brake drum	$12.0 \pm 0.5 \text{kgf} \cdot \text{m}$ ($86.8 \pm 3.6 \text{lb} \cdot \text{ft}$)

4) DISK BRAKE

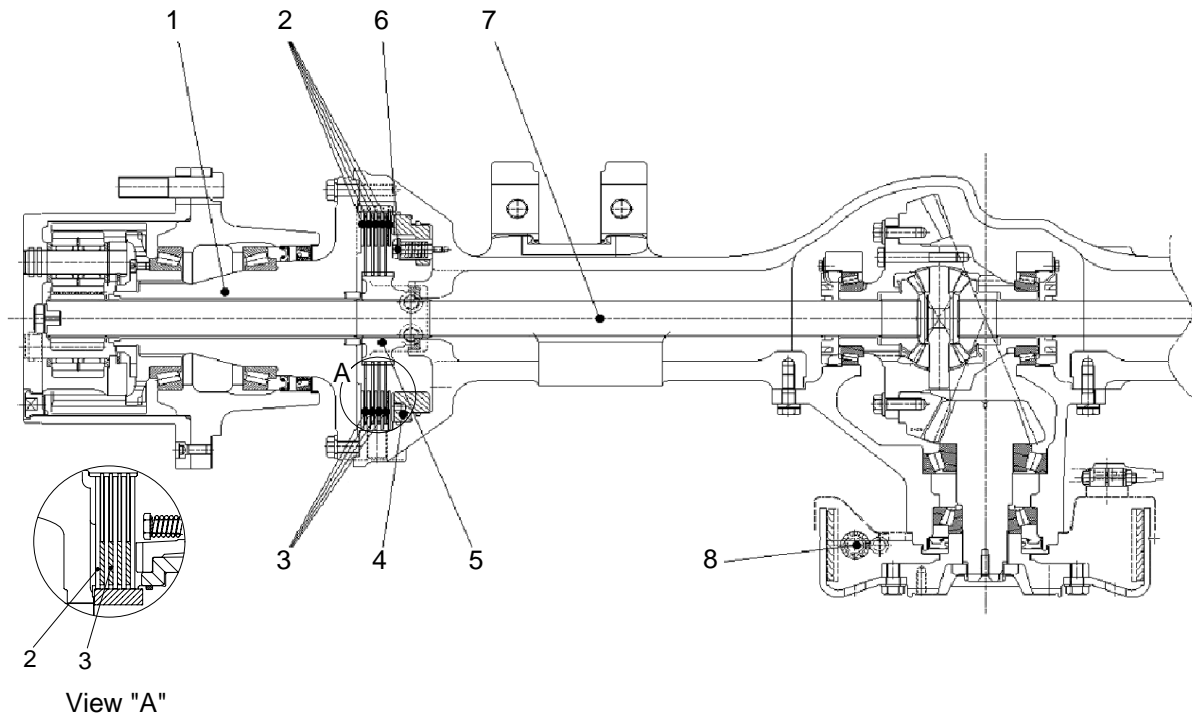

50D7EAX05

- | | | |
|---------------|------------------------------|-----------------|
| 1 Spindle | 4 Service piston | 7 Drive shaft |
| 2 Steel plate | 5 Service collar | 8 Parking brake |
| 3 Disk plate | 6 Service piston adjust bolt | |

OPERATION

Sealed up structure of hydraulic multi-disk brake system secures good brake performance even in the high humid or dusty area.

Because it is possible to use the brake semi-permanently, there is no need to maintain its lining as drum type brake do. Also with self-adjust of friction plate clearance, it's easy to prevent the brake performance drop due to friction material wear.

Major components are 3 disk plates (3), 4 steel plates (2), service piston (4) and 4 piston adjust bolts (5). Braking take places when the discs and plates are pressed each other which make rotation resistance to the collar (6) and the drive shaft (7).

7. TIRE AND WHEEL

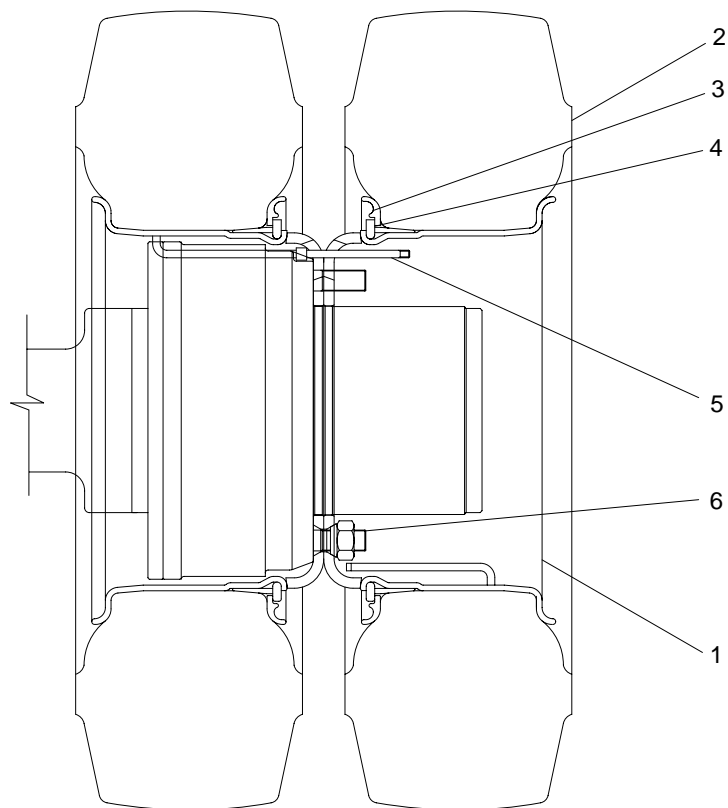

B507AX68

- | | | | | | |
|---|-----------|---|-----------|---|----------------|
| 1 | Wheel rim | 3 | Lock ring | 5 | Valve assembly |
| 2 | Tire | 4 | Side ring | 6 | Wheel nut |

- 1) The tire acts to absorb the shock from the ground surface to the machine, and at the same time they must rotate in contact with the ground to gain the power which drives the machine.
- 2) Various types of tires are available to suit the purpose. Therefore it is very important to select the correct tires for the type of work.

GROUP 2 OPERATION AND MAINTENANCE

1. OPERATION

1) DRIVING PREPARATION AND MAINTENANCE

Prior to the commissioning of the transmission, take care that the prescribed oil grade will be filled in with the correct quantity. At the initial filling of the transmission has to be considered that the oil cooler, the pressure filters as well as the pipes must get filled with oil.

According to these cavities, the quantity of oil to be filled in, is greater than at the later oil fillings in the course of the usual maintenance service.

- ※ Because the converter and the oil cooler, installed in the vehicle, as well as the pipes can empty at standstill into the transmission, the **oil level check must be carried out at engine idling speed and operation temperature of the transmission.**

▲ At the oil level check, the vehicle has to be secured against rolling by blocks, articulated vehicles additionally against unintended turning-in.

2) DRIVING AND SHIFTING

(1) Neutral position

Neutral position will be selected via the gear selector.

After the ignition is switched on, the electronics remains in the waiting state. By the position NEUTRAL of the gear selector, the TCU becomes ready for operation.

A gear can be engaged.

(2) Starting

The starting of the engine has always to be carried out in the NEUTRAL POSITION of the gear selector.

For safety reasons it is to recommend to brake the vehicle securely in position with the parking brake prior to start the engine.

After the starting of the engine and the preselection of the driving direction and the gear, the vehicle can be set in motion by acceleration.

At the start off, the converter takes over the function of a master clutch.

On a level road it is possible to start off also in higher gears.

- Upshifting under load.

Upshifting under load will be then realized if the vehicle can continue to accelerate by it.

- Downshifting under load.

Downshifting under load will be then realized if more traction force is needed.

- Upshifting in overrunning condition.

In the overrunning mode, the upshifting will be suppressed by accelerator pedal idling position, if the speed of the vehicle on a downgrade should not be further increased.

- Downshifting in overrunning condition.

Downshifting in overrunning mode will be then carried out if the vehicle should be related.

If the vehicle will be stopped and is standing with running engine and engaged transmission, the engine cannot be stalled. On a level and horizontal roadway it is possible that the vehicle begins to crawl, because the engine is creating at idling speed a slight drag torque via the converter.

It is convenient to brake the vehicle at very stop securely in position with the parking brake. At longer stops, the controller has to be shifted to the NEUTRAL POSITION.

At the start off, the parking brake has to be released. We know from experience that at a converter transmission it might not immediately be noted to have forgotten this quite normal operating step because a converter, due to its high ratio, can easily overcome the braking torque of the parking brake.

Temperature increases in the converter oil as well as overheated brakes will be the consequences to be find out later.

Neutral position of the selector switch at higher vehicle speed(above stepping speed) is not admissible.

Either a suitable gear is to be shifted immediately, or vehicle must be stopped at once.

3) COLD START

At an oil temperature in the shifting circuit $<-12^{\circ}\text{C}$, the transmission must be warmed-up for some minutes.

This must be carried out in neutral with an increased engine speed(about 1500min^{-1}).

Until this oil temperature is reached, the electronics remains in neutral, and the symbol of the cold start phase will be indicated on the display.

Indication on the display: **

After the indication on the display is extinguished, the full driving program can be utilized out of "NEUTRAL".

4) OIL TEMPERATURE

The oil temperature in the transmission sump is in the electrohydraulic control unit.

The service temperature in the sump of $60\text{--}90^{\circ}\text{C}$ must not be exceeded.

By overstepping results by 105°C notice "WS" on the display.

At a trouble-free unit and an adequate driving mode, a higher temperature will not occur.

The notice "WS" results at the display, the vehicle has to be stopped and controlled for external oil loss and the engine must run with a speed of $1200\text{--}1500\text{min}^{-1}$ at NEUTRAL POSITION of the transmission.

Now, the temperature must drop quickly(in about 2-3minutes) to normal values. If this is not the case, there is a trouble pending, which must be eliminated prior to continue working.

The monitoring of the oil temperature(behind the converter) is additionally on the temperature gauge which is located on the dashboard.

Operating temperature behind the converter at least 65° C and 100° C in continuous operation, a short-time increase up to max. 120° C is permitted.

The temperature is measured on the measuring point "63" (see schedule of measuring points-3-22)

2. MAINTENANCE

1) TRANSMISSION

(1) Oil level check

▲ At the oil level check, the vehicle has to be secured against rolling with blocks.

The oil level check must be carried out as follows :

- Oil level check(weekly)
- At horizontally standing vehicle
- Transmission in neutral position "N"
- In the cold start phase, the engine must be running about 2-3minutes at idling speed, and the marking on the oil dipstick must then be lying above the cold start mark "COLD"
- At operating temperature of the transmission(about 80~90° C)
- At engine idling speed
- Loosen oil dipstick by counterclock rotation, remove and clean it
- Insert oil dipstick slowly into the oil level tube until contact is obtained, and pull it out again.
- On the oil dipstick, the oil level must be lying in the zone "HOT"
- Insert the oil dipstick again, and tighten it by clockwise rotation

If the oil level has dropped in operating temperature condition below the "HOT" zone, it is absolutely necessary to replenish oil.

An oil level above the "HOT" marking, is leading to a too high oil temperature.

(2) Oil change and filter replacement intervals

※ **First oil change after 100 operating hours in service.**

Every further oil change after 1000 operating hours in service, however at least once a year.

At every oil change, the fine filter has to be replaced.

① Oil change and oil filling capacity

The oil change has to be carried out as follows. At operating temperature of the transmission, horizontally standing vehicle open the oil drain plug and drain the used oil.

- Clean oil drain plug with magnetic insert and surface on the housing and install again along with O-ring.

- Fill in oil (about 24 liters).

(Sump capacity, external oil capacities e. g. in the heat exchanger, in the lines etc. are depended on the vehicle).

The indicated value is a guide value.

※ **It is imperative to pay attention to absolute cleanliness of oil and filter.**

Binding is in any case the making on the oil dipstick.

- Start the engine-idling speed

- Transmission in neutral position "N"

- Top up oil up to the marking "COLD"

- Brake the vehicle securely in position and warm up the transmission

- Shift all controller positions through

- Check the oil level once more and top up oil once more if necessary

- On the oil dipstick, the oil level must be lying in the zone "HOT"

- Insert the oil dipstick again and tighten it by clockwise rotation

※ At the initial filling of the transmission has to be considered that the heat exchanger, the pressure filter as well as the pipes must get filled with oil.

According to these cavities, the oil capacity to be filled in is greater than at the later oil fillings in the course of the usual maintenance service.

② Filter replacement

At the replacement of the filter in the main oil steam, pay attention that no dirt or oil sludge can penetrate into the circuit.

At the mounting of the filter, any exertion of force has to be avoided.

※ Treat the filter carefully at the installation, the transport and the storage.

Damaged filters must no more be installed.

The mounting of the filter must be carried out as follows:

- Cover the gasket with a small amount of oil.

- Screw the filter in until contact with the sealing surface is obtained and tighten it now by hand about 1/3 to 1/2 turn.

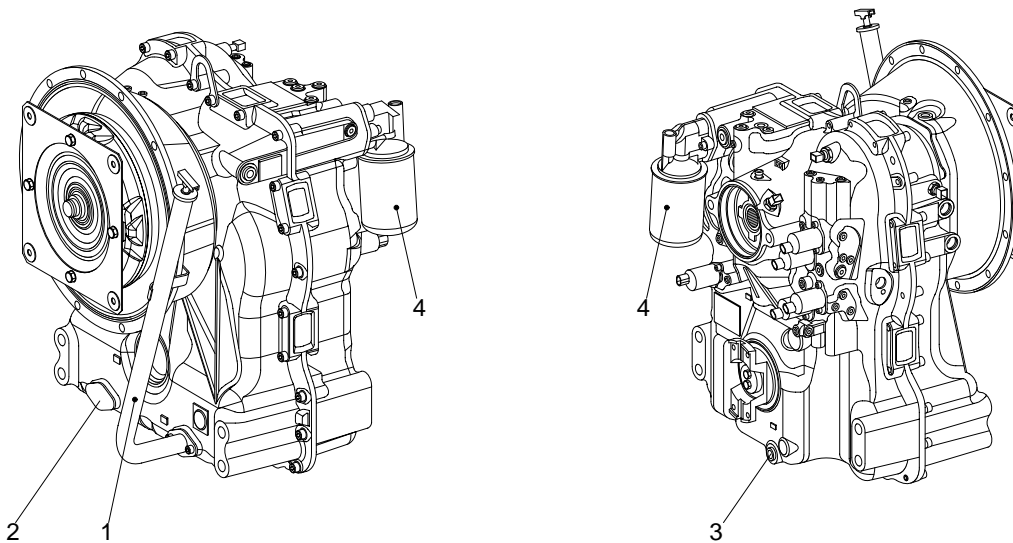

50DS7EPT19

Legend:

- 1 = Oil filler tube with oil dipstick
- 2 = Mounting provision for oil filler tube with oil dipstick(option)
- 3 = Oil drag plug 7/8" 14 UNF 2B
- 4 = Fine filter

Oil dipstick

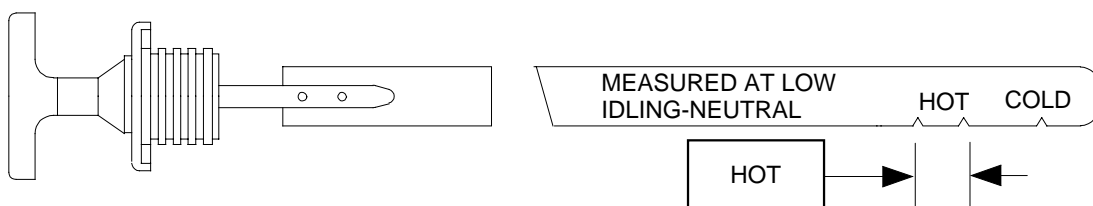

D507PT20

2) DRIVE AXLE

(1) General information

Drive axles generate small metal wear particles at a fairly steady rate, especially during the break-in period. If these fine, but hard particles are allowed to circulate in the lubricant, along with external moisture and dirt, internal components will wear at a much faster rate than normal.

(2) Magnets and magnetic drain plugs

Planetary axles are equipped with magnetic drain plug that have a minimum pick-up capacity of 0.57kg(20 ounces) of low carbon steel. The drain plug must be checked for metal particles at every oil change interval.

※ Hyundai recommends replacing the magnetic drain plug each time the oil is changed.

Use the correct part. Pipe plugs will leak if used as a drain plug.

The magnetic drain plug can be reused if, after cleaning, the plug has a minimum pick-up capacity of 0.57kg(20 ounces) of low carbon steel.

(3) Breather

▲ Cover the breather when steam cleaning the housing. If the breather is not covered, water can enter the housing and contaminate the oil.

Breathers release pressure and vacuum condensation to minimize premature oil and component failure.

(4) Oil level

▲ Check and adjust oil

▲ To prevent serious eye injury, always wear safe eye protection when you perform vehicle maintenance or service.

※ Fill and drain plugs are located in both brake housing and the main housing.

① Make sure the vehicle is on a level surface.

※ For axles with a common oil level that have drain and fill plugs only in the axle assembly, proceed to step ③.

② Rotate the wheels so that the "Oil level lines" on the wheel ends are parallel to the ground.

③ Clean the area around the fill/level plug.

Remove the fill/level plug from the wheel ends and the axle housing bowl. The oil level must be even with the bottom of the hole of the fill/level plug.

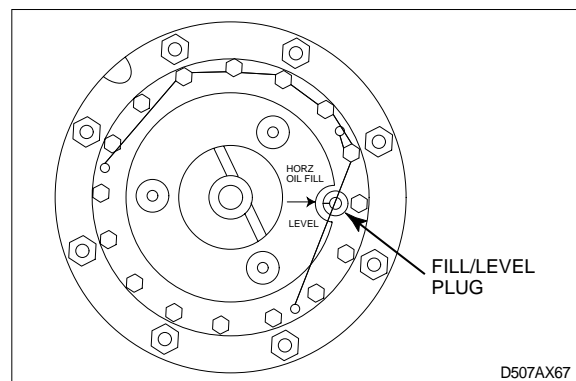

- ④ **If oil flows from the hole when you loosen the plug** : The oil level is high. Let the oil drain to the correct level.
 ※ Do not fill only through the axle housing bowl.
- ⑤ **If the oil level is below the bottom of the hole of the fill/level plug** : Fill the axle at each wheel end and the axle housing bowl to the bottom of the fill plug hole with the specified oil. Wait and allow the oil to flow through the axle.
 Check the oil level again and fill to the specified level if necessary.
- ⑥ Install the fill/level plugs. Apply thread compound and tighten. Refer to the "Torque table".

(5) Oil change

▲ Park the vehicle on a level surface. Block the wheels to prevent the vehicle from moving. Support the vehicle with safety stands. Do not work under a vehicle supported only by jacks. Jacks can slip and fall over. Serious personal injury can result.

- ① Make sure the vehicle is on a level surface.
 Put large containers under the axle and wheel ends.
- ② Raise the vehicle so that the wheels are off the ground. Support the vehicle with safety stands.
- ③ Rotate the wheels so that the "fill/level" plugs in the wheel ends are toward the ground.
- ④ Remove the drain plugs from both brake housing and the main housing. Drain and discard the oil properly. Clean the plug.
- ⑤ Install the drain plugs in both brake housings and the main housing. Apply thread compound and tighten. Refer to the "torque table".
- ⑥ Rotate the wheels so that the " oil level lines" on the wheel ends are parallel to the ground.
 Lower the vehicle.
- ⑦ Clean the area around the fill/level plug.
 Remove the fill/level plug from the wheel ends and the axle housing bowl.
 ※ Do not fill only through the axle housing bowl.
- ⑧ Fill the axle at each wheel end and the axle housing bowl to the bottom of the fill plugs hole with the specified oil. Wait and allow the oil to flow through the axle. Check the oil level again and fill to the specified level if necessary.
- ⑨ Install the fill/level plugs. Apply thread compound and tighten. Refer to the "torque table".

(6) Oil change intervals and specifications

Off-highway operation intervals*				Oil specification	Remarks
Recommended initial oil change	Check oil level	Petroleum oil change	Synthetic oil change	Transmission oil	Initial use or refill
100 operating hours	250 operating hours*	1,000 operating hours or twice a year (whichever comes first)	-	Transmission oil	OK to use only for refill

* The checking interval depends on individual operating conditions, speeds and loads, severe operating conditions may require more frequent checks.

3. TROUBLESHOOTING

1) DRIVE AXLE

(1) BRAKE LEAKS ACTUATION FLUID

Condition	Possible cause	Correction
Internal leak : Fluid bypasses seals into axle and fills axle with fluid and blows out breather or empties brake fluid reservoir.	<ol style="list-style-type: none">1. Worn or damaged piston seal.2. Melted or extruded piston seals.3. Corrosion, pitting, wear or other damage, marks, scratches to piston and/or brake housing bore in area of seal/sealing lips.	<ol style="list-style-type: none">1. Replace piston seals.2. Correct cause of overheating and replace seals.3. Clean, smooth, rework or replace affected parts.
External leak	<ol style="list-style-type: none">1. Loose bleeder screw.2. Loose inlet fitting or plugs.3. Damaged inlet fitting or plugs or damaged seats.	<ol style="list-style-type: none">1. Tighten bleeder screw to 2.0~2.7kgf·m(15-20lb-ft)2. Tighten inlet fitting to 3.4~4.8kgf·m(25-35 lb-ft)3. Replace inlet fitting or plug and O-ring if used.

(2) BRAKE NOISE AND VIBRATION

Condition	Possible cause	Correction
Brakes product noise, chatter, vibration.	Incorrect axle fluid and/or friction material used.	<ol style="list-style-type: none">1. Use only approved materials.2. Drain and flush fluid from axle. Replace with approved fluid.3. Replace all friction discs. Thoroughly clean or replace stationary discs.

(3) BRAKE OVERHEATS

Condition	Possible cause	Correction
Overheating due to excessive duty cycle.	Inadequate coolant flow or heat exchange.	<ol style="list-style-type: none"> 1. Install brake cooling system if not already installed on vehicle. 2. Re-analyze and re-size brake cooling system if necessary.
Inadequate coolant flow	Low pump output, blocked filter or coolant lines.	Check pump output at different operating modes. Replace filter and check lines.
Low or no coolant.	<ol style="list-style-type: none"> 1. Improper fill or leaks. 2. Leaking face seal. 3. Loose or damaged plugs. 4. Deteriorated or inadequate sealant used at joint. 	<ol style="list-style-type: none"> 1. Check for proper fill level. 2. Replace or reinstall face seal assembly. 3. Tighten drain, fill or forced cooling plug. Replace if damaged. 4. Disassemble, clean, re-seal and re-assemble brake housing joint.
Brake drags.	<ol style="list-style-type: none"> 1. More than 1.4bar(20psi) pressure applies when brakes released. 2. Damaged piston return spring assembly. 3. Piston not returning. 4. Wrong cooling and/or actuation fluid used. 5. Tight or damaged splines(eg. friction disc-to-hub driver). 	<ol style="list-style-type: none"> 1. Repair hydraulic system so pressure is less than 1.4bar(20psi) when brakes released and while machine is operating in any mode. 2. Repair or replace piston return spring assembly. 3. Check piston seals and seal separator. 4. Check piston seals and seal separator for swelling or damaged. Replace as necessary. Purge system and use correct fluid. 5. Repair or replace parts.

(4) BRAKE DOES NOT APPLY

Condition	Possible cause	Correction
Low or no pressure to brake	<ol style="list-style-type: none"> 1. Empty fluid reservoir. 2. Damaged hydraulic system. 3. Leaked of brake actuation fluid. 4. Parking brake not adjusted properly. 	<ol style="list-style-type: none"> 1. Fill reservoir to correct level with specified fluid. 2. Repair hydraulic system. 3. Refer to "Brake leaks actuation fluid" in this section. 4. Adjust parking brake lever as described in assembly of this manual.

(5) BRAKE DOES NOT RELEASE

Condition	Possible cause	Correction
Vehicle does not move	Damaged hydraulic system.	Repair hydraulic system.
Brakes dragging	<ol style="list-style-type: none"> 1. More than 1.4bar(20psi) pressure applied when brakes released. 2. Damaged piston return spring assembly. 3. Piston not returning. 4. Wrong cooling and/or actuation fluid used. 5. Parking brake not adjusted properly. 	<ol style="list-style-type: none"> 1. Repair hydraulic system so pressure is less than 1.4bar(20psi) when brakes released and while machine is operating in any mode. 2. Repair or replace piston return spring assembly. 3. Check piston seals for swelling or damage. Replace as necessary. 4. Check piston seals for swelling or damage. Purge system and use specified fluid. 5. Adjust parking brake lever as described in assembly of this manual.

(6) BRAKING PERFORMANCE

Condition	Possible cause	Correction
Noticeable change or decrease in stopping performance.	<ol style="list-style-type: none"> 1. Inadequate actuation fluid supply to brakes. 2. Inadequate pressure to apply brakes. 3. Worn or damaged discs. 4. Overheated seals and/or discs. 5. Dirty or contaminated cooling fluid. 	<ol style="list-style-type: none"> 1. Replenish fluid in brake system. Check for leakage and correct cause. 2. Check brakes apply system. Check for leakage in brake system or brakes, and correct cause. 3. Inspect and replace discs if necessary. ※ As disc wear occurs, make sure brake system can supply adequate fluid to fully apply brakes. 4. Inspect and replace discs and seals if necessary. 5. Drain and flush cooling fluid from brakes and entire brake system. Replace with approved fluid. In some cases, it may necessary to replace discs. Clean or replace filter.
Brake does not fully apply.	<ol style="list-style-type: none"> 1. Empty fluid reservoir. 2. Damaged hydraulic system. 3. Leakage of brake actuation fluid. 	<ol style="list-style-type: none"> 1. Fill reservoir to correct level with specified fluid. 2. Repair hydraulic system. 3. Refer to "Brake leaks actuation fluid" in this section.
Brakes fell spongy/soft.	Brakes or brake system not properly bled.	Bleed brakes and brake system.

(7) DIFFERENTIAL

No	Problem	Cause	Remedy
1	Constant noise in differential.	<ol style="list-style-type: none"> 1. Oil is not enough. (Replace interval : 50 hrs first, then every 500 hrs) 2. Wrong kind of oil. 3. Wheel bearings out of adjustment or have a defect. 4. Drive gear and pinion not in adjustment for correct tooth contact. 5. Teeth of drive gear and pinion have been damaged or worn. 6. Gear backlash is too much or too little. 7. Loose or worn on pinion bearings. 8. Loose or worn on side earing. 	<ul style="list-style-type: none"> • Refueling lubricating oil. • Change lubricating oil. • Change bearing. • Re-assemble. • Change damaged gear. • Change differential gear set. • Change bearing. • Change bearing.
2	Noise at different intervals.	<ol style="list-style-type: none"> 1. Ring gear does not run even. (1) Bolts on drive gear are not tightened correctly. (2) Drive gear has a defect (warped) 2. Loose or broken differential bearings. 	<ul style="list-style-type: none"> • Tighten bolts. • Change differential pinion gear or spider. • Change bearing.
3	Noise on turns only.	<ol style="list-style-type: none"> 1. Differential pinion gears are tight on the spider. 2. Side gears are tight in differential case. 3. Differential pinion or side gears have a defect. 4. Thrust washers worn or have a damage. 5. Too much clearance (backlash) between side gears and pinions. 	<ul style="list-style-type: none"> • Change differential pinion gear or spider. • Change differential side gear. • Change differential gear set. • Change differential washer. • Change differential gear set.
4	Leakage of the oil.	<ol style="list-style-type: none"> 1. Leakage through axle hub carrier. (1) Too much oil. (2) Wrong kind of oil. (3) Much restriction on air eather. 2. Leakage around pinion shaft. (1) Too much oil. (2) Wrong kind of oil. (3) Much restriction on air eather. (4) Oil seal worn or not installed correctly. 	<ul style="list-style-type: none"> • Adjust oil level • Change lubricating oil. • Change air breather. • Adjust oil level. • Change lubricating oil. • Change air breather. • Change oil seal.
5	Drive wheels do not rotate.	<ol style="list-style-type: none"> 1. Broken axle shaft. (1) Loose wheel bearings. (2) Axle shaft too short. (3) Loose flange studs or nuts. 2. Drive gear teeth have been damaged. 3. Side gear on differential damaged. 4. Differential pinion shaft or spider broken. 	<ul style="list-style-type: none"> • Re-assemble wheel bearings. • Replace drive shaft. • Tighten studs or nuts. • Change damaged drive gear set. • Change damaged gear. • Change damaged gear.

2) TRANSMISSION

(1) GENERAL INSPECTION WHILE DRIVING

No	Problem	Cause
1	Failure at the specific gear stage	1. Low oil pressure or no pressure. <ul style="list-style-type: none"> 1) No oil, low level or high oil viscosity. 2) Loose inching control valve connection, incorrect adjustment or damage. 3) Inching valve spool stuck or open. 4) Oil pump damage or defect. 5) T/C pump gear side bolt breakage or gear not meshing with pump. 6) Main regulator valve stuck or open. 7) Oil circuit clogged or strainer contaminated. 8) T/M inside leakage. <ul style="list-style-type: none"> Control valve gasket damage. - Clutch shaft metal sealing wear or damage. - Clutch piston seal damage or wear. 9) Control valve gasket wear cause oil leakage. 2. Abnormal connection of outer line of cooler. 3. Mechanical defect inside the T/M
2	Gear shift failure	1. Low oil pressure. 2. Main regulator valve does not move. 3. Malfunctioning of solenoid or relative electric components.
3	T/M overheating	1. Clogged cooling line. 2. Oil level is too high or too low. 3. Low pump pressure, pump wear or defect. 4. Partial clutch wear or slip 5. Air mixed with oil, air leakage at the pump input port. 6. Insufficient oil flow through the T/C. 7. Overload on the machine. 8. Too excessive inching operation. 9. Too excessive stall operation of T/C. 10. Cooler bypass valve stick or open. Oil flow insufficient through oil cooler.

No	Problem	Cause
4	Slow clutch meshing or failure	1. Low oil pressure. 2. Low converter oil pressure. 3. Air mixed with oil 1) Air mixed through the pump input port. 2) Low oil level 4. Abnormal adjustment of inching valve linkage.
5	Reverse gear shift failure	1. Excessive wear of disk and plate at reverse clutch. 2. Oil leakage from seal. 3. Reverse clutch components defect. 1) Metal sealing wear or defect. 2) Clutch piston seal wear or defect. 3) Another components damaged. 4. Malfunction of solenoid or related electric parts.
6	Forward gear shift failure	1. Excessive wear of disk and plate at forward clutch. 2. Oil leakage from seal. 3. Forward clutch components defect. 1) Metal sealing wear or defect. 2) Clutch piston seal wear or defect. 3) Another components damaged. 4. Malfunction of solenoid or related electric parts.
7	Low stall speed	1. Incorrect engine performance. 2. Torque converter stator failure.
8	High stall speed at all of gear stage	1. Low oil level. 2. Air mixed with oil. 3. Clutch slip. 4. T/C malfunctioning.
9	High stall speed at partial direction or speed	1. Clutch line leakage. 2. Clutch defect.
10	Slow clutch meshing and rough gear shift	1. Incorrect adjustment of inching valve. 2. Inching valve not closed or clogged orifice. 3. Low main pressure. 4. Low pressure of direction clutch. 5. Oil leakage. 6. Valve spool spring weakened or damaged.
11	Abnormal movement to the specified direction at neutral	1. Clutch defect, clutch disk and plate damaged. 2. Valve spool defect or spool stucked.

(2) ABNORMAL NOISE CHECK LIST

No	Problem	Cause
1	Noise only at neutral	<ol style="list-style-type: none">1. Gear or bearing wear inside the pump.2. Torque converter stator wear.3. Low oil level.4. Gear parts of engine and T/M pump's misalignment with that of converter housing and pump.
2	Pump noise	<ol style="list-style-type: none">1. Loud noise irregularly repeats if there's contaminants in the T/M hydraulic components.2. Regular noise means pump defect.
3	T/M noise	<ol style="list-style-type: none">1. Converter housing and pump gear misalignment with engine or T/M2. T/M components wear or damage.<ol style="list-style-type: none">1) Gear damage.2) Clutch plate and disk slip noise.3) Thrust washer defect.4) Another components wear or damage.
4	Control valve noise	<ol style="list-style-type: none">1. Air mixed into hydraulic system.<ol style="list-style-type: none">1) Air leakage from the pump input port.2. Clogged oil passage.3. Abnormal spool movement.

(3) PRESSURE TEST CHECK LIST

No	Problem	Cause
1	FR/RR clutch low pressure	Incorrect adjustment of inching valve linkage
		Inching spool stucked and open.
		Clutch and piston oil leakage.
		Regulator spring defect.
		Low oil pressure.
		Incorrect connection of cooler external line.
2	High clutch and main pressure	Pressure regulation valve does not move smoothly.
		Clogged hydraulic line.
3	Low clutch pressure	Oil leakage due to incorrect assembly of clutch piston seal.
		Damage or wear of clutch piston seal and shaft seal.
		Valve contact surface not flat or gasket damage.
4	Low main pressure	Low oil quantity
		Pressure regulation valve does not move smoothly.
		Pump wear
		Internal leakage
		Low oil pressure
5	High converter pressure	Main regulation valve stucked and open, oil overflow to converter.
		Clogged internal passage of converter assembly.
		Clogged oil line.
6	Low converter pressure	Clogged main regulator valve.
7	Low converter output pressure, cooler input pressure.	Low oil pressure
		Cooler bypass valve stucked and open.
8	High converter output pressure, cooler input pressure	Clogged or restricted cooler line.

(4) Transmission fault codes

Fault code (Hex)	Meaning of the fault code possible reason for fault detection	Reaction of the TCU	Possible steps to repair
11	<p>Logical error at gear range signal TCU detected a wrong signal combination for the gear range</p> <ul style="list-style-type: none"> · Cable from shift lever to TCU is broken · Cable is defective and is contacted to battery voltage or vehicle ground · Shift lever is defective 	<p>TCU shifts transmission to neutral OP-mode : Transmission shutdown</p>	<ul style="list-style-type: none"> · Check the cables from TCU to shift lever · Check signal combinations of shift lever positions for gear range ※ Failure cannot be detected in systems with DW2/DW3 shift lever. Fault is taken back if TCU detects a valid signal for the position
12	<p>Logical error at direction select signal TCU detected a wrong signal combination for the direction</p> <ul style="list-style-type: none"> · Cable from shift lever to TCU is broken · Cable is defective and is contacted to battery voltage or vehicle ground · Shift lever is defective 	<p>TCU shifts transmission to neutral OP-Mode : Transmission shutdown</p>	<ul style="list-style-type: none"> · Check the cables from TCU to shift lever · Check signal combinations of shift lever positions F-N-R ※ Fault is taken back if TCU detects a valid signal for the direction at the shift lever
25	<p>S.C. to battery voltage or O.C. at transmission sump temperature sensor input The measured voltage is too high:</p> <ul style="list-style-type: none"> · Cable is defective and is contacted to battery voltage · Cable has no connection to TCU · Temperature sensor has an internal defect · Connector pin is contacted to battery voltage or is broken 	<p>No reaction, TCU use default temperature OP mode : Normal</p>	<ul style="list-style-type: none"> · Check the cable from TCU to the sensor · Check the connectors · Check the temperature sensor
26	<p>S.C. to ground at transmission sump temperature sensor input The measured voltage is too low:</p> <ul style="list-style-type: none"> · Cable is defective and is contacted to vehicle ground · Temperature sensor has an internal defect · Connector pin is contacted to vehicle ground 	<p>No reaction, TCU uses default temperature OP mode : Normal</p>	<ul style="list-style-type: none"> · Check the cable from TCU to the sensor · Check the connectors · Check the temperature sensor
27	<p>S.C. to battery voltage or O.C. at retarder/torque converter temperature sensor input The measured voltage is too high:</p> <ul style="list-style-type: none"> · Cable is defective and is contacted to battery voltage · Cable has no connection to TCU · Temperature sensor has an internal defect · Connector pin is contacted to battery voltage or is broken 	<p>No reaction, TCU uses default temperature OP mode : Normal</p>	<ul style="list-style-type: none"> · Check the cable from TCU to the sensor · Check the connectors · Check the temperature sensor

Fault code (Hex)	Meaning of the fault code possible reason for fault detection	Reaction of the TCU	Possible steps to repair
28	<p>S.C. to ground at retarder/torque converter temperature sensor input The measured voltage is too low:</p> <ul style="list-style-type: none"> · Cable is defective and is contacted to vehicle ground · Temperature sensor has an internal defect · Connector pin is contacted to vehicle ground 	No reaction, TCU uses default temperature OP mode : Normal	<ul style="list-style-type: none"> · Check the cable from TCU to the sensor · Check the connectors · Check the temperature sensor
2B	<p>Inch sensor-signal mismatch the measured voltage from CCO and CCO2 signal don't match :</p> <ul style="list-style-type: none"> · Cable is defective · Sensor has an internal defect 	During inching mode : TCU shifts to neutral While not inching : no change OP-Mode : normal	<ul style="list-style-type: none"> · Check the cable from TCU to the sensor · Check the connectors · Check the sensor
31	<p>S.C. to battery voltage or O.C. at engine speed input TCU measures a voltage higher than 7.00V at speed input pin</p> <ul style="list-style-type: none"> · Cable is defective and is contacted to battery voltage · Cable has no connection to TCU · Speed sensor has an internal defect · Connector pin is contacted to battery voltage or has no contact 	OP mode : Substitute clutch control	<ul style="list-style-type: none"> · Check the cable from TCU to the sensor · Check the connectors · Check the speed sensor
32	<p>S.C. to ground at engine speed input TCU measures a voltage less than 0.45V at speed input pin</p> <ul style="list-style-type: none"> · Cable/connector is defective and is contacted to vehicle ground · Speed sensor has an internal defect 	OP mode : Substitute clutch control	<ul style="list-style-type: none"> · Check the cable from TCU to the sensor · Check the connectors · Check the speed sensor
33	<p>Logical error at engine speed input TCU measures a engine speed over a threshold and the next moment the measured speed is zero</p> <ul style="list-style-type: none"> · Cable/connector is defective and has bad contact · Speed sensor has an internal defect · Sensor gap has the wrong size 	OP mode : Substitute clutch control	<ul style="list-style-type: none"> · Check the cable from TCU to the sensor · Check the connectors · Check the speed sensor · Check the sensor gap <p>※ This fault is reset after power up of TCU</p>
34	<p>S.C. to battery voltage or O.C. at turbine speed input TCU measures a voltage higher than 7.00V at speed input pin</p> <ul style="list-style-type: none"> · Cable is defective and is contacted to vehicle battery voltage · Cable has no connection to TCU · Speed sensor has an internal defect · Connector pin is contacted to battery voltage or has no contact 	OP mode : Substitute clutch control If a failure is existing at output speed, TCU shifts to neutral OP mode : Limp home	<ul style="list-style-type: none"> · Check the cable from TCU to the sensor · Check the connectors · Check the speed sensor

Fault code (Hex)	Meaning of the fault code possible reason for fault detection	Reaction of the TCU	Possible steps to repair
35	<p>S.C. to ground at turbine speed input TCU measures a voltage less than 0.45V at speed input pin</p> <ul style="list-style-type: none"> · Cable/connector is defective and is contacted to vehicle ground · Speed sensor has an internal defect 	<p>OP mode : Substitute clutch control</p> <p>If a failure is existing at output speed, TCU shifts to neutral OP mode : Limp home</p>	<ul style="list-style-type: none"> · Check the cable from TCU to the sensor · Check the connectors · Check the speed sensor <p>※ This fault is reset after power up of TCU</p>
36	<p>Logical error at turbine speed input TCU measures a turbine speed over a threshold and at the next moment the measured speed is zero</p> <ul style="list-style-type: none"> · Cable/connector is defective and has bad contact · Speed sensor has an internal defect · Sensor gap has the wrong size 	<p>OP mode : Substitute clutch control</p> <p>If a failure is existing at output speed, TCU shifts to neutral OP mode : Limp home</p>	<ul style="list-style-type: none"> · Check the cable from TCU to the sensor · Check the connectors · Check the speed sensor · Check the sensor gap
37	<p>S.C. to battery voltage or O.C. at internal speed input TCU measures a voltage higher than 7.00V at speed input pin</p> <ul style="list-style-type: none"> · Cable is defective and is contacted to vehicle battery voltage · Cable has no connection to TCU · Speed sensor has an internal defect · Connector pin is contacted to battery voltage or has no contact 	<p>OP mode : Substitute clutch control</p>	<ul style="list-style-type: none"> · Check the cable from TCU to the sensor · Check the connectors · Check the speed sensor
38	<p>S.C. to ground at internal speed input TCU measures a voltage less than 0.45V at speed input pin</p> <ul style="list-style-type: none"> · Cable/connector is defective and is contacted to vehicle ground · Speed sensor has an internal defect 	<p>OP mode : Substitute clutch control</p>	<ul style="list-style-type: none"> · Check the cable from TCU to the sensor · Check the connectors · Check the speed sensor
39	<p>Logical error at internal speed input TCU measures a internal speed over a threshold and at the next moment the measured speed is zero</p> <ul style="list-style-type: none"> · Cable/connector is defective and has bad contact · Speed sensor has an internal defect · Sensor gap has the wrong size 	<p>OP mode : Substitute clutch control</p>	<ul style="list-style-type: none"> · Check the cable from TCU to the sensor · Check the connectors · Check the speed sensor · Check the sensor gap <p>※ This fault is reset after power up of TCU</p>
3A	<p>S.C. to battery voltage or O.C. at output speed input TCU measures a voltage higher than 12.5V at speed input pin</p> <ul style="list-style-type: none"> · Cable is defective and is contacted to battery voltage · Cable has no connection to TCU · Speed sensor has an internal defect · Connector pin is contacted to battery voltage or has no contact 	<p>Special mode for gear selection OP mode : Substitute clutch control</p> <p>If a failure is existing at turbine speed, TCU shifts to neutral OP mode : lamp home</p>	<ul style="list-style-type: none"> · Check the cable from TCU to the sensor · Check the connectors · Check the speed sensor

Fault code (Hex)	Meaning of the fault code possible reason for fault detection	Reaction of the TCU	Possible steps to repair
3B	S.C. to ground at output speed input TCU measures a voltage less than 1.00V at speed input pin · Cable/connector is defective and is contacted to vehicle ground · Speed sensor has an internal defect	Special mode for gear selection OP mode : Substitute clutch control If a failure is existing at turbine speed, TCU shifts to neutral OP mode : lamp home	<ul style="list-style-type: none"> · Check the cable from TCU to the sensor · Check the connectors · Check the speed sensor
3C	Logical error at output speed input TCU measures a turbine speed over a threshold and at the next moment the measured speed is zero · Cable/connector is defective and has bad contact · Speed sensor has an internal defect · Sensor gap has the wrong size	Special mode for gear selection OP mode : Substitute clutch control If a failure is existing at turbine speed, TCU shifts to neutral OP mode : lamp home	<ul style="list-style-type: none"> · Check the cable from TCU to the sensor · Check the connectors · Check the speed sensor · Check the sensor gap <p>※ This fault is reset after power up of TCU</p>
3E	Output speed zero doesn't fit to other speed signals If transmission is not neutral and the shifting has finished, TCU measures output speed zero and turbine speed or internal speed not equal to zero. · Speed sensor has an internal defect · Sensor gap has the wrong size	Special mode for gear selection OP mode : Substitute clutch control If a failure is existing at turbine speed, TCU shifts to neutral OP mode : lamp home	<ul style="list-style-type: none"> · Check the sensor signal of output speed sensor · Check the sensor gap of output speed sensor · Check the cable from TCU to the sensor <p>※ This fault is reset after power up of TCU</p>
54	Vehicle1 timeout Time of CAN-message Vehicle1 from display computer · Interference on CAN-Bus · CAN wire/connector is broken · CAN wire/connector is defective and has contact to vehicle ground or battery voltage	TCU shifts to neutral NN(because of shifting lever)	<ul style="list-style-type: none"> · Check vehicle controller · Check wire of CAN-Bus · Check cable to vehicle controller
57	EEC1 timeout Timeout of CAN-message EEC1 from EEC controller · Interference on CAN-Bus · CAN wire/connector is broken · CAN wire/connector is defective and has contact to vehicle ground or battery voltage	OP-Mode : substitute clutch control	<ul style="list-style-type: none"> · Check EEC controller · Check wire of CAN-Bus · Check cable to EEC controller
71	S.C. to battery voltage at clutch KC The measured resistance value of the valve is out of limit, the voltage at KC valve is too high · Cable/connector is defective and has contact to battery voltage · Regulator has an internal defect	TCU shifts to neutral OP mode : Limp home If failure at another clutch is pending TCU shifts to neutral OP mode : TCU shutdown	<ul style="list-style-type: none"> · Check the cable from TCU to the gearbox · Check the connectors from TCU to the gearbox · Check the regulator resistance* · Check internal wire harness of the gearbox <p>* See page 3-56</p>

Fault code (Hex)	Meaning of the fault code possible reason for fault detection	Reaction of the TCU	Possible steps to repair
72	<p>S.C. to ground at clutch KC The measured resistance value of the valve is out of limit, the voltage at KC valve is too low</p> <ul style="list-style-type: none"> · Cable/connector is defective and has contact to vehicle ground · Cable/connector is defective and has contact to another regulator output of the TCU · Regulator has an internal defect 	<p>TCU shifts to neutral OP mode : Limp home If failure at another clutch is pending TCU shifts to neutral OP mode : TCU shutdown</p>	<ul style="list-style-type: none"> · Check the cable from TCU to the gearbox · Check the connectors from gearbox to TCU · Check the regulator resistance* · Check internal wire harness of the gearbox <p>* See page 3-56</p>
73	<p>O.C. at clutch KC The measured resistance value of the valve is out of limit</p> <ul style="list-style-type: none"> · Cable/connector is defective and has no contact to TCU · Regulator has an internal defect 	<p>TCU shifts to neutral OP mode : Limp home If failure at another clutch is pending TCU shifts to neutral OP mode : TCU shutdown</p>	<ul style="list-style-type: none"> · Check the cable from TCU to the gearbox · Check the connectors from gearbox to TCU · Check the regulator resistance* · Check internal wire harness of the gearbox <p>* See page 3-56</p>
74	<p>S.C. to battery voltage at clutch KD The measured resistance value of the valve is out of limit, the voltage at KD valve is too high</p> <ul style="list-style-type: none"> · Cable/connector is defective and has contact to battery voltage · Regulator has an internal defect 	<p>TCU shifts to neutral OP mode : Limp home If failure at another clutch is pending TCU shifts to neutral OP mode : TCU shutdown</p>	<ul style="list-style-type: none"> · Check the cable from TCU to the gearbox · Check the connectors from gearbox to TCU · Check the regulator resistance* · Check internal wire harness of the gearbox <p>* See page 3-56</p>
75	<p>S.C. to ground at clutch KD The measured resistance value of the valve is out of limit, the voltage at KD valve is too low</p> <ul style="list-style-type: none"> · Cable/connector is defective and has contact to vehicle ground · Cable/connector is defective and has contact to another regulator output of the TCU · Regulator has an internal defect 	<p>TCU shifts to neutral OP mode : Limp home If failure at another clutch is pending TCU shifts to neutral OP mode : TCU shutdown</p>	<ul style="list-style-type: none"> · Check the cable from TCU to the gearbox · Check the connectors from gearbox to TCU · Check the regulator resistance* · Check internal wire harness of the gearbox <p>* See page 3-56</p>
76	<p>O.C. at clutch KD The measured resistance value of the valve is out of limit</p> <ul style="list-style-type: none"> · Cable/connector is defective and has no contact to TCU · Regulator has an internal defect 	<p>TCU shifts to neutral OP mode : Limp home If failure at another clutch is pending TCU shifts to neutral OP mode : TCU shutdown</p>	<ul style="list-style-type: none"> · Check the cable from TCU to the gearbox · Check the connectors from gearbox to TCU · Check the regulator resistance* · Check internal wire harness of the gearbox <p>* See page 3-56</p>
77	<p>S.C. to battery voltage at clutch KE The measured resistance value of the valve is out of limit, the voltage at KE valve is too high</p> <ul style="list-style-type: none"> · Cable/connector is defective and has contact to battery voltage · Regulator has an internal defect 	<p>TCU shifts to neutral OP mode : Limp home If failure at another clutch is pending TCU shifts to neutral OP mode : TCU shutdown</p>	<ul style="list-style-type: none"> · Check the cable from TCU to the gearbox · Check the connectors from gearbox to TCU · Check the regulator resistance* · Check internal wire harness of the gearbox <p>* See page 3-56</p>

Fault code (Hex)	Meaning of the fault code possible reason for fault detection	Reaction of the TCU	Possible steps to repair
78	<p>S.C. to ground at clutch KE The measured resistance value of the valve is out of limit, the voltage at KE valve is too low</p> <ul style="list-style-type: none"> • Cable/connector is defective and has contact to vehicle ground • Cable/connector is defective and has contact to another regulator output of the TCU • Regulator has an internal defect 	<p>TCU shifts to neutral OP mode : Limp home If failure at another clutch is pending TCU shifts to neutral OP mode : TCU shutdown</p>	<ul style="list-style-type: none"> • Check the cable from TCU to the gearbox • Check the connectors from gearbox to TCU • Check the regulator resistance* • Check internal wire harness of the gearbox <p>* See page 3-56</p>
79	<p>O.C. at clutch KE The measured resistance value of the valve is out of limit</p> <ul style="list-style-type: none"> • Cable/connector is defective and has no contact to TCU • Regulator has an internal defect 	<p>TCU shifts to neutral OP mode : Limp home If failure at another clutch is pending TCU shifts to neutral OP mode : TCU shutdown</p>	<ul style="list-style-type: none"> • Check the cable from TCU to the gearbox • Check the connectors from gearbox to TCU • Check the regulator resistance* • Check internal wire harness of the gearbox <p>* See page 3-56</p>
84	<p>S.C. to battery voltage at clutch KV The measured resistance value of the valve is out of limit, the voltage at KV valve is too high</p> <ul style="list-style-type: none"> • Cable/connector is defective and has contact to battery voltage • Regulator has an internal defect 	<p>TCU shifts to neutral OP mode : Limp home If failure at another clutch is pending TCU shifts to neutral OP mode : TCU shutdown</p>	<ul style="list-style-type: none"> • Check the cable from TCU to the gearbox • Check the connectors from gearbox to TCU • Check the regulator resistance* • Check internal wire harness of the gearbox <p>* See page 3-56</p>
85	<p>S.C. to ground at clutch KV The measured resistance value of the valve is out of limit, the voltage at KV valve is too low</p> <ul style="list-style-type: none"> • Cable/connector is defective and has contact to vehicle ground • Cable/connector is defective and has contact to another regulator output of the TCU • Regulator has an internal defect 	<p>TCU shifts to neutral OP mode : Limp home If failure at another clutch is pending TCU shifts to neutral OP mode : TCU shutdown</p>	<ul style="list-style-type: none"> • Check the cable from TCU to the gearbox • Check the connectors from gearbox to TCU • Check the regulator resistance* • Check internal wire harness of the gearbox <p>* See page 3-56</p>
86	<p>O.C. at clutch KV The measured resistance value of the valve is out of limit</p> <ul style="list-style-type: none"> • Cable/connector is defective and has contact to TCU • Regulator has an internal defect 	<p>TCU shifts to neutral OP mode : Limp home If failure at another clutch is pending TCU shifts to neutral OP mode : TCU shutdown</p>	<ul style="list-style-type: none"> • Check the cable from TCU to the gearbox • Check the connectors from gearbox to TCU • Check the regulator resistance* • Check internal wire harness of the gearbox <p>* See page 3-56</p>
87	<p>S.C. to battery voltage at clutch KR The measured resistance value of the valve is out of limit, the voltage at KR valve is too high</p> <ul style="list-style-type: none"> • Cable/connector is defective and has contact to battery voltage • Regulator has an internal defect 	<p>TCU shifts to neutral OP mode : Limp home If failure at another clutch is pending TCU shifts to neutral OP mode : TCU shutdown</p>	<ul style="list-style-type: none"> • Check the cable from TCU to the gearbox • Check the connectors from gearbox to TCU • Check the regulator resistance* • Check internal wire harness of the gearbox <p>* See page 3-56</p>

Fault code (Hex)	Meaning of the fault code possible reason for fault detection	Reaction of the TCU	Possible steps to repair
88	<p>S.C. to ground at clutch KR The measured resistance value of the valve is out of limit, the voltage at KR valve is too low</p> <ul style="list-style-type: none"> • Cable/connector is defective and has contact to vehicle ground • Cable/connector is defective and has contact to another regulator output of the TCU • Regulator has an internal defect 	<p>TCU shifts to neutral OP mode : Limp home If failure at another clutch is pending TCU shifts to neutral OP mode : TCU shutdown</p>	<ul style="list-style-type: none"> • Check the cable from TCU to the gearbox • Check the connectors from gearbox to TCU • Check the regulator resistance* • Check internal wire harness of the gearbox <p>* See page 3-56</p>
89	<p>O.C. at clutch KR The measured resistance value of the valve is out of limit</p> <ul style="list-style-type: none"> • Cable/connector is defective and has no contact to TCU • Regulator has an internal defect 	<p>TCU shifts to neutral OP mode : Limp home If failure at another clutch is pending TCU shifts to neutral OP mode : TCU shutdown</p>	<ul style="list-style-type: none"> • Check the cable from TCU to the gearbox • Check the connectors from gearbox to TCU • Check the regulator resistance* • Check internal wire harness of the gearbox <p>* See page 3-56</p>
B1	<p>Slippage at clutch KC TCU calculates a differential speed at closed clutch KC. If this calculated value is out of range, TCU interprets this as slipping clutch</p> <ul style="list-style-type: none"> • Low pressure at clutch KC • Low main pressure • Wrong signal at internal speed sensor • Wrong signal at output speed sensor • Wrong size of the sensor gap • Clutch is defective 	<p>TCU shifts to neutral OP mode : Limp home If failure at another clutch is pending TCU shifts to neutral OP mode : TCU shutdown</p>	<p>Check pressure at clutch KC Check main pressure in the system Check sensor gap at internal speed sensor Check sensor gap at output speed sensor Check signal at internal speed sensor Check signal at output speed sensor Replace clutch</p>
B2	<p>Slippage at clutch KD TCU calculates a differential speed at closed clutch KD. If this calculated value is out of range, TCU interprets this as slipping clutch</p> <ul style="list-style-type: none"> • Low pressure at clutch KD • Low main pressure • Wrong signal at internal speed sensor • Wrong signal at output speed sensor • Wrong size of the sensor gap • Clutch is defective 	<p>TCU shifts to neutral OP mode : Limp home If failure at another clutch is pending TCU shifts to neutral OP mode : TCU shutdown</p>	<p>Check pressure at clutch KD Check main pressure in the system Check sensor gap at internal speed sensor Check sensor gap at output speed sensor Check signal at internal speed sensor Check signal at output speed sensor Replace clutch</p>

Fault code (Hex)	Meaning of the fault code possible reason for fault detection	Reaction of the TCU	Possible steps to repair
B3	<p>Slippage at clutch KE TCU calculates a differential speed at closed clutch KE. If this calculated value is out of range, TCU interprets this as slipping clutch</p> <ul style="list-style-type: none"> • Low pressure at clutch KE • Low main pressure • Wrong signal at internal speed sensor • Wrong signal at output speed sensor • Wrong size of the sensor gap • Clutch is defective 	<p>TCU shifts to neutral OP mode : Limp home If failure at another clutch is pending TCU shifts to neutral OP mode : TCU shutdown</p>	<ul style="list-style-type: none"> • Check pressure at clutch KE • Check main pressure in the system • Check sensor gap at internal speed sensor • Check sensor gap at output speed sensor • Check signal at internal speed sensor • Check signal at output speed sensor • Replace clutch
B5	<p>Slippage at clutch KV TCU calculates a differential speed at closed clutch KV. If this calculated value is out of range, TCU interprets this as slipping clutch</p> <ul style="list-style-type: none"> • Low pressure at clutch KV • Low main pressure • Wrong signal at internal speed sensor • Wrong signal at turbine speed sensor • Wrong size of the sensor gap • Clutch is defective 	<p>TCU shifts to neutral OP mode : Limp home If failure at another clutch is pending TCU shifts to neutral OP mode : TCU shutdown</p>	<ul style="list-style-type: none"> • Check pressure at clutch KV • Check main pressure in the system • Check sensor gap at internal speed sensor • Check sensor gap at turbine speed sensor • Check signal at internal speed sensor • Check signal at turbine speed sensor • Replace clutch
B6	<p>Slippage at clutch KR TCU calculates a differential speed at closed clutch KR. If this calculated value is out of range, TCU interprets this as slipping clutch</p> <ul style="list-style-type: none"> • Low pressure at clutch KR • Low main pressure • Wrong signal at internal speed sensor • Wrong signal at turbine speed sensor • Wrong size of the sensor gap • Clutch is defective 	<p>TCU shifts to neutral OP mode : Limp home If failure at another clutch is pending TCU shifts to neutral OP mode : TCU shutdown</p>	<ul style="list-style-type: none"> • Check pressure at clutch KR • Check main pressure in the system • Check sensor gap at internal speed sensor • Check sensor gap at turbine speed sensor • Check signal at internal speed sensor • Check signal at turbine speed sensor • Replace clutch
B7	<p>Overtemp sump TCU measured a temperature in the oil sump that is over the allowed threshold.</p>	<p>No reaction OP mode : Normal</p>	<ul style="list-style-type: none"> • Cool down machine • Check oil level • Check temperature sensor
B8	<p>Overtemp converter TCU measured a temperature in the retarder oil that is over the allowed threshold</p>	<p>No reaction OP mode : Normal</p>	<ul style="list-style-type: none"> • Cool down machine • Check oil level • Check temperature sensor
B9	<p>Overspend engine</p>	<p>Retarder applies OP mode : Normal</p>	-
BC	<p>Overtemp converter TCU measured a transmission output speed above the define threshold</p>	<p>No reaction OP mode : Normal</p>	
C0	<p>Engine torque or engine power overload TCU calculates an engine torque or engine power above the defined thresholds</p>	<p>OP mode : Normal</p>	

Fault code (Hex)	Meaning of the fault code possible reason for fault detection	Reaction of the TCU	Possible steps to repair
C1	Transmission output torque overload TCU calculates an transmission output torque above the defined threshold	OP mode : Normal	
C2	Transmission input torque overload TCU calculates an transmission output torque above the defined threshold	programmable : No reaction or shift to neutral OP mode : Normal	
C3	Overtemp converter output TCU measured a oil temperature at the converter output that is the allowed threshold	No reaction OP mode : Normal	<ul style="list-style-type: none"> · Cool down machine · Check oil level · Check temperature sensor
D1	S.C. to battery voltage at power supply for sensors TCU measures more than 6V at the pin AU1 (5V sensor supply)	See fault codes No.21 to 2C	<p>Check cables and connectors to sensors, which are supplied from AU1</p> <p>Check the power supply at the pin AU1(Should be appx. 5V)</p> <p>Fault codes No.21 to No.2C may be reaction of this fault</p>
D2	S.C. to ground at power supply for sensors TCU measures less than 4V at the pin AU1 (5V sensor supply)	See fault codes No.21 to 2C	<p>Check cables and connectors to sensors, which are supplied from AU1</p> <p>Check the power supply at the pin AU1(Should be appx. 5V)</p> <p>Fault codes No.21 to No.2C may be reaction of this fault</p>
D3	Low voltage at battery Measured voltage at power supply is lower than 18V(24V device)	Shift to neutral OP mode : TCU shutdown	<p>Check power supply battery</p> <p>Check cables from batteries to TCU</p> <p>Check connectors from batteries to TCU</p>
D4	High voltage at battery Measured voltage at power supply is higher than 32.5V(24V device)	Shift to neutral OP mode : TCU shutdown	<p>Check power supply battery</p> <p>Check cables from batteries to TCU</p> <p>Check connectors from batteries to TCU</p>
D5	Error at valve power supply VPS1 TCU switched on VPS1 and measured VPS1 is off or TCU switched off VPS1 and measured VPS1 is still on <ul style="list-style-type: none"> · Cable or connectors are defect and are contacted to battery voltage · Cable or connectors are defect and are contacted to vehicle ground · Permanent power supply KL30 missing · TCU has an internal defect 	Shift to neutral OP mode : TCU shutdown	<p>Check fuse</p> <p>Check cables from gearbox to TCU</p> <p>Check connectors from gearbox to TCU</p> <p>Replace TCU</p>
D6	Error at valve power supply VPS2 TCU switched on VPS2 and measured VPS2 is off or TCU switched off VPS2 and measured VPS2 is still on <ul style="list-style-type: none"> · Cable or connectors are defect and are contacted to battery voltage · Cable or connectors are defect and are contacted to vehicle ground · Permanent power supply KL30 missing · TCU has an internal defect 	Shift to neutral OP mode : TCU shutdown	<p>Check fuse</p> <p>Check cables from gearbox to TCU</p> <p>Check connectors from gearbox to TCU</p> <p>Replace TCU</p>

Fault code (Hex)	Meaning of the fault code possible reason for fault detection	Reaction of the TCU	Possible steps to repair
E3	S.C. to battery voltage at display output TCU sends data to the display and measures always a high voltage level on the connector <ul style="list-style-type: none"> · Cable or connectors are defective and are contacted to battery voltage · Display has an internal defect 	No reaction OP mode : Normal	<ul style="list-style-type: none"> · Check the cable from TCU to the display · Check the connectors at the display · Change display
E4	S.C. to ground at display output TCU sends data to the display and measures always a high voltage level on the connector <ul style="list-style-type: none"> · Cable or connectors are defective and are contacted to battery voltage · Display has an internal defect 	No reaction OP mode : Normal	<ul style="list-style-type: none"> · Check the cable from TCU to the display · Check the connectors at the display · Change display
F1	General EEPROM fault TCU can't read non volatile memory <ul style="list-style-type: none"> · TCU is defective 	No reaction OP mode : Normal	<ul style="list-style-type: none"> · Replace TCU ※ Often shown together with fault code F2
F2	Configuration lost TCU has lost the correct configuration and can't control the transmission <ul style="list-style-type: none"> · Interference during saving data on non volatile memory · TCU is brand new or from another vehicle 	Transmission stay neutral OP mode : TCU shutdown	<ul style="list-style-type: none"> · Reprogram the correct configuration for the vehicle (e.g. with cluster controller,...)
F3	Application error Something of this application is wrong	Transmission stay neutral OP mode : TCU shutdown	<ul style="list-style-type: none"> · Replace TCU ※ This fault occurs only if an test engineer did something wrong in the application of the vehicle
F5	Clutch failure AEB was not able to adjust clutch filling parameters <ul style="list-style-type: none"> · One of the AEB-Values is out of limit 	Transmission stay neutral OP mode : TCU shutdown	<ul style="list-style-type: none"> · Check clutch ※ TCU shows also the affected clutch on the display
F6	Clutch adjustment data lost or Inch pedal calibration data lost TCU was not able to read correct clutch adjustment parameters <ul style="list-style-type: none"> · Interference during saving data on non volatile memory · TCU is brand new 	No reaction, Default values : 0 for AEB Offsets used OP mode : Normal	<ul style="list-style-type: none"> · Execute AEB

(5) Measuring of resistance at actuator/sensor and cable

① Actuator

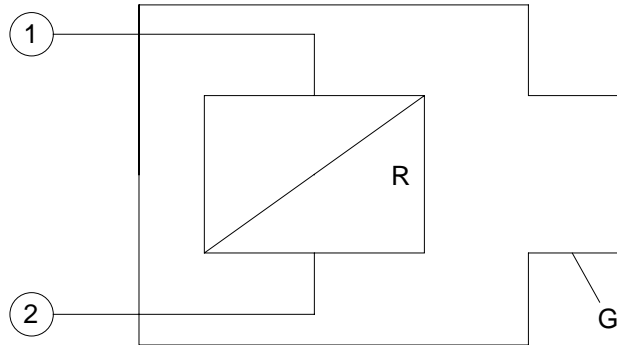

76043PT19

Open circuit	$R_{12} = R_{1G} = R_{2G} = \infty$
Short cut to ground	$R_{12} = R$; $R_{1G} = 0, R_{2G} = R$ or $R_{1G} = R, R_{2G} = 0$ (For S.C. to ground, G is connected to vehicle ground)
Short cut to battery	$R_{12} = R$; $R_{1G} = 0, R_{2G} = R$ or $R_{1G} = R, R_{2G} = 0$ (For S.C. to battery, G is connected to battery voltage)

② Cable

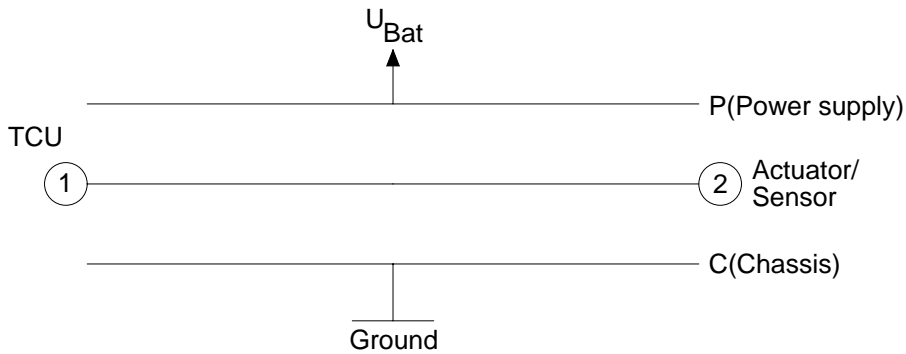

76043PT20

Open circuit	$R_{12} = R_{1P} = R_{1C} = R_{2P} = R_{2C} = \infty$
Short cut to ground	$R_{12} = 0$; $R_{1C} = R_{2C} = 0, R_{1P} = R_{2P} = \infty$
Short cut to battery	$R_{12} = 0$; $R_{1C} = R_{2C} = 0, R_{1P} = R_{2P} = 0$

GROUP 3 DISASSEMBLY AND ASSEMBLY

1. TRANSMISSION DISASSEMBLY

1) DISASSEMBLY

Transmission 3 WG-94 EC

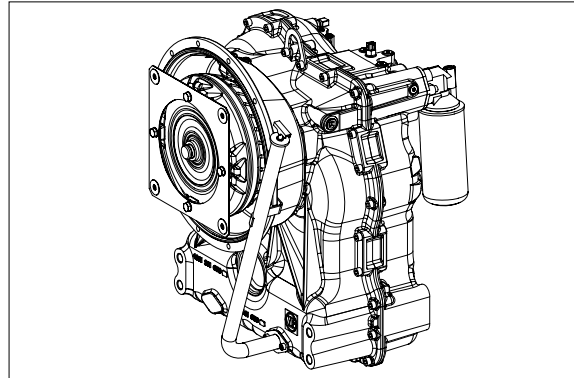

50DS7ETM11

- ① Attach transmission to the assembly truck by means of clamping angles(1) and holding fixtures(2).

(S) Assembly truck	5870 350 000
(S) Holding fixtures	5870 350 063
(S) Clamping angles	5870 350 124

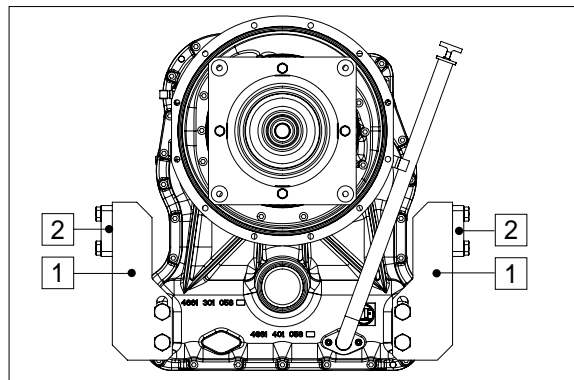

50DS7ETM12

(1) Removal of the filter

※ Drain oil prior to starting disassembly.

- ① Remove screw plug(1).

▲ Disposal of oil according to legal requirements.

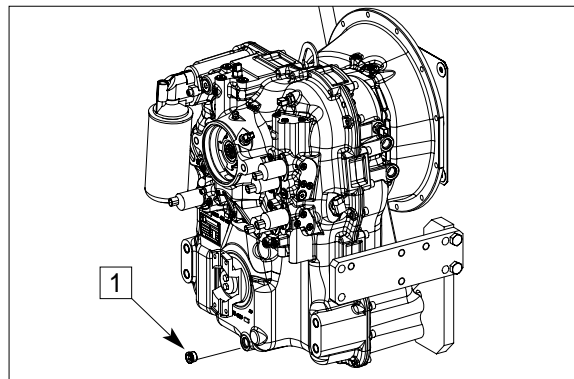

50DS7ETM13

- ② Loosen the cylindrical screws(1) and remove the oil filler tube with the oil dipstick(2).

※ Remove the O-ring(3) from the oil filler tube.

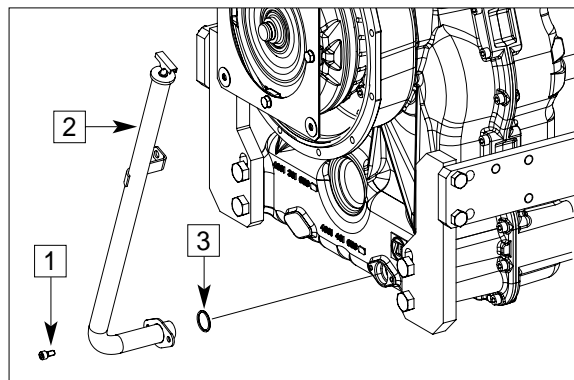

50DS7ETM14

- ③ Separate the fine filter(1) from the filter head by means of belt wrench.

(S) Belt wrench 5870 105 005

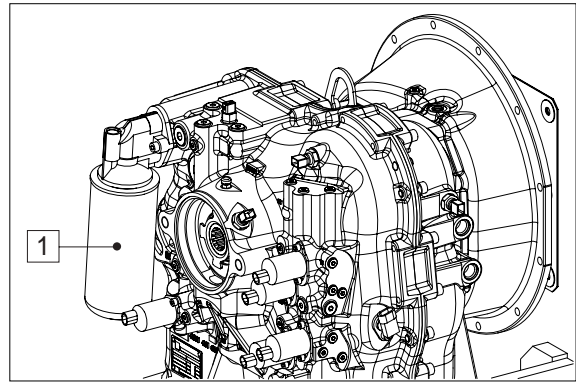

50DS7ETM15

- ④ Loosen the cylindrical screws(2) and separate the filter head(1) from the transmission housing.

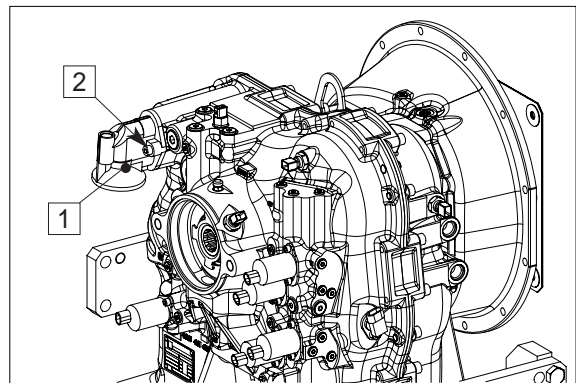

50DS7ETM16

- ⑤ Remove both O-rings(1) out of the annular groove of the filter head.

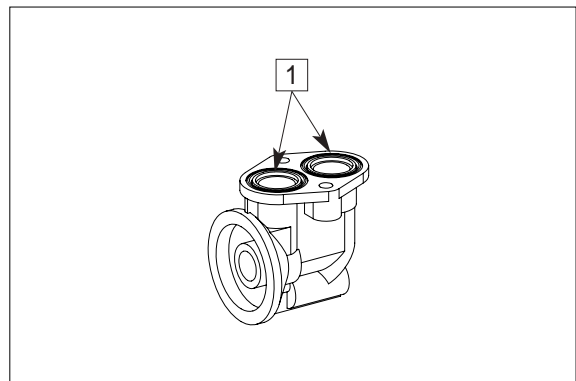

50DS7ETM17

2) DISASSEMBLY PRESSURE CONTROLLER (PROPORTIONAL VALVES), INDUCTIVE SENSOR, SPEED SENSOR(HALL SENSOR), TEMPERATURE SENSOR, BREATHER AND SCREW PLUGS

① Remove all screw plugs with O-ring(1 and 2).

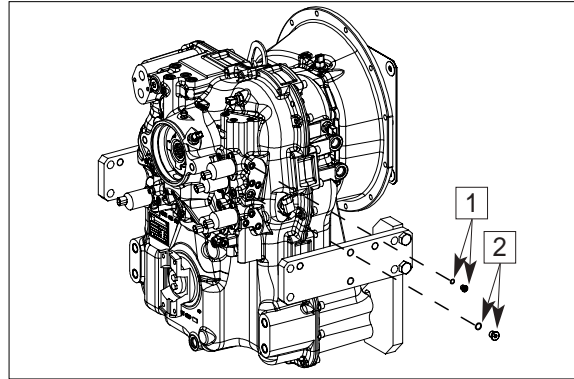

50DS7ETM18

② Loosen cylindrical screws(1) and remove pressure controller(proportional valves, 2).

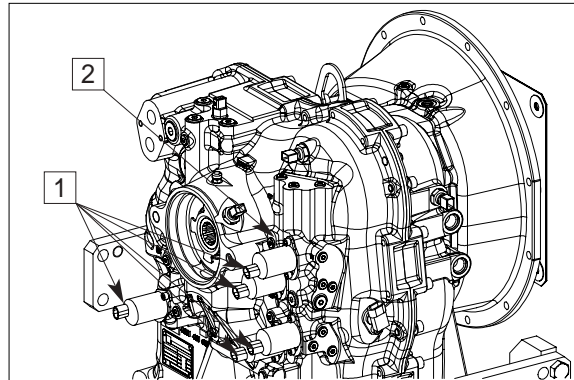

50DS7ETM19

③ Remove positioned parts.

- 1 = Inductive sensor-n turbine
- 2 = Inductive sensor-n central gear chain
- 3 = Temperature sensor, measuring point "63" after converter
- 4 = Inductive sensor

※ Remove O-rings.

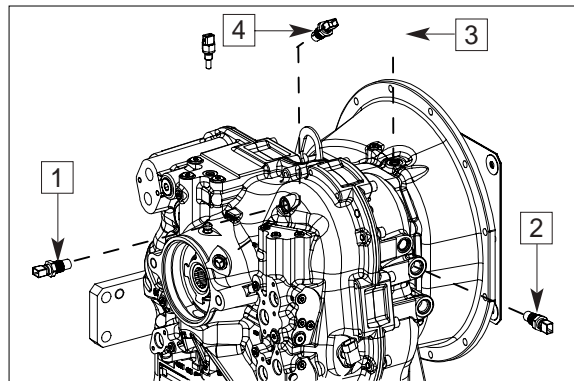

50DS7ETM20

④ Loosen cylindrical screw(1) and remove speed sensor(2).

2 = Speed sensor-n output(Hall sensor)

※ Remove O-rings.

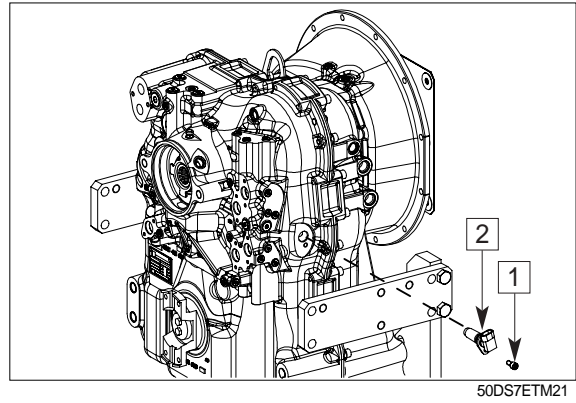

⑤ Remove breather (1).

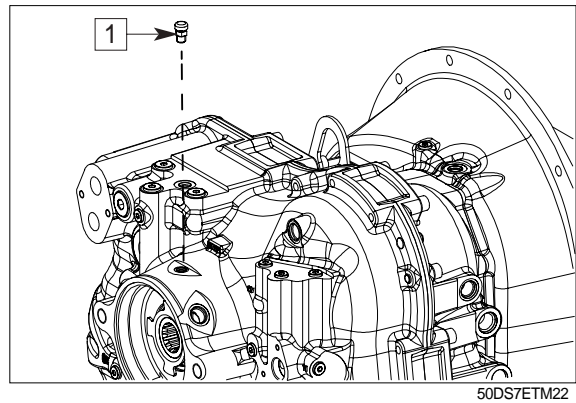

3) DISASSEMBLY CONVERTER AND CENTRAL SHAFT(PTO SHAFT)

- ① Loosen cylindrical screws(1) and separate the flexplate(2) from the converter(3).

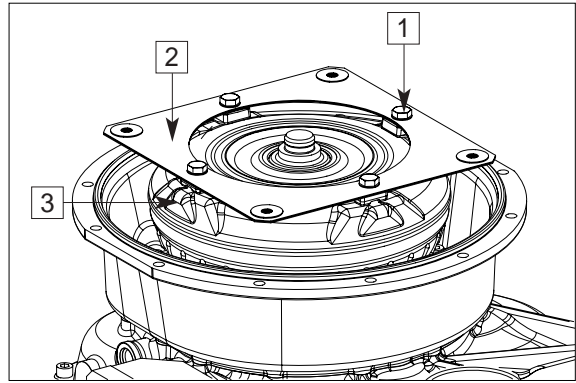

50DS7ETM23

- ② Pull off converter(1) by hand.

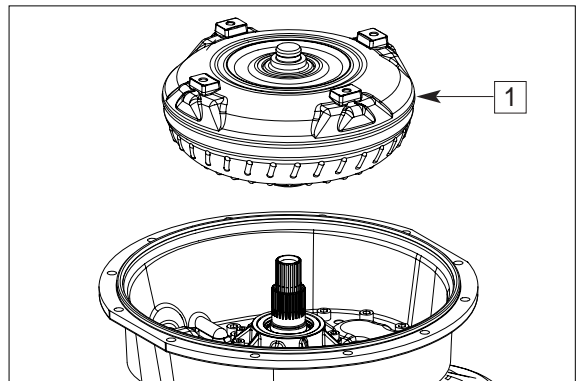

50DS7ETM24

- ③ Disengage the retaining ring(see arrow).

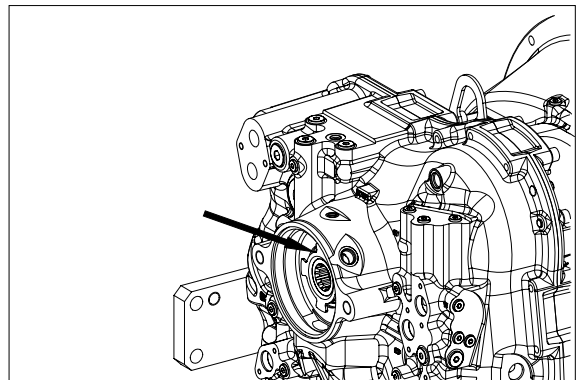

50DS7ETM25

- ④ Pull the central shaft assy out of the housing hole.

- 1 = Central shaft
- 2 = Retaining ring
- 3 = Ball bearing
- 4 = Toothed disk

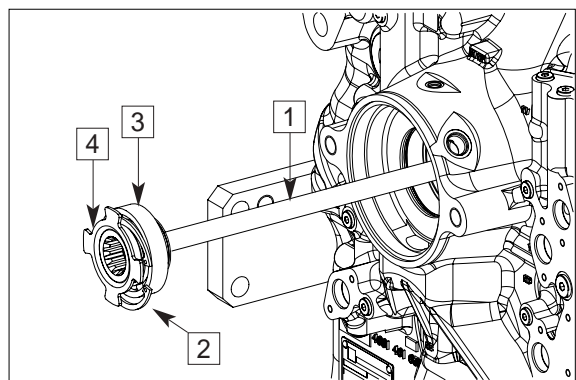

50DS7ETM26

- ⑤ Pull the toothed disk(1) from the central shaft.

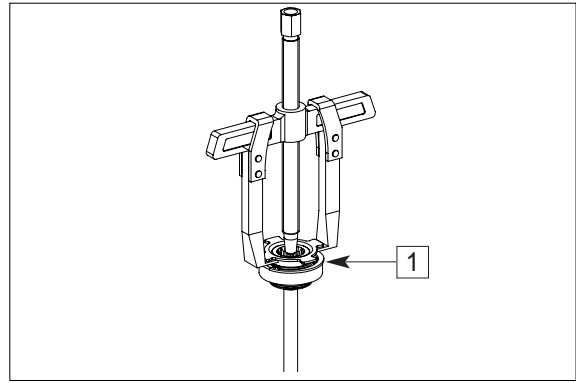

50DS7ETM27

- ⑥ Press the ball bearing(1) from the central shaft(2).

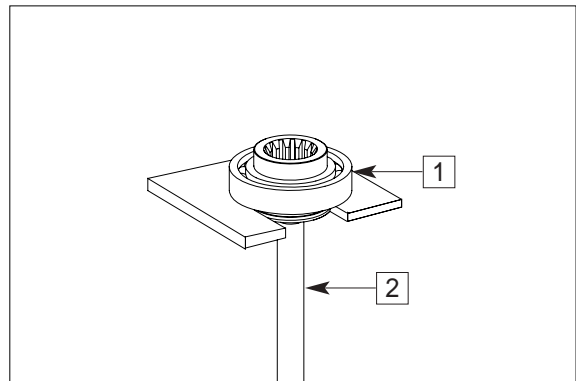

50DS7ETM28

4) DISASSEMBLY OF OUTPUT FLANGE

- ① Loosen the hexagon screws(1) and remove disk and O-ring(2 and 3).

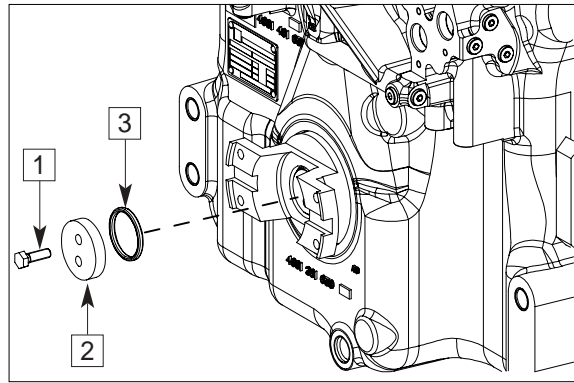

- ② Pull output flange(1) off the output shaft by means of two-armed puller.

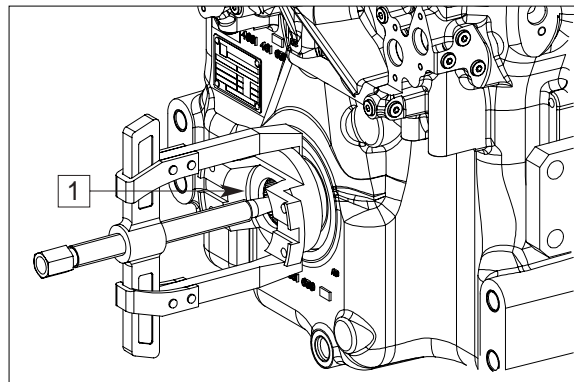

- ③ Remove shaft seal(see arrow) from the housing hole by means of assembly lever.

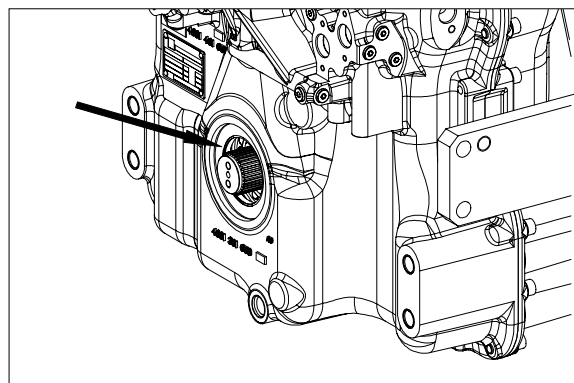

5) DISASSEMBLY OF MAIN PRESSURE VALVE AND CONVERTER SAFETY VALVE

- ① Loosen screw plug(1) and remove main pressure valve(control pressure valve):

Main pressure valve consists of:

- 1 = Screw plug with O-ring
- 2 = Piston
- 3 = Spacer rings
- 4 = Compression spring

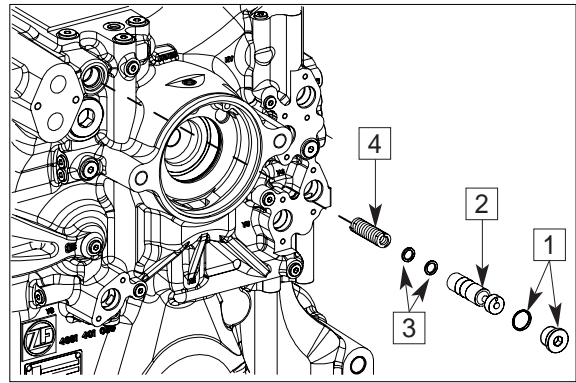

- ② Loosen screw plug(1) and remove converter safety valve.

Converter safety valve consists of :

- 1 = Screw plug with O-ring
- 2 = Pressure valves
- = Valve assy is installed in the housing- not visible-(functional check of valve see below ③).

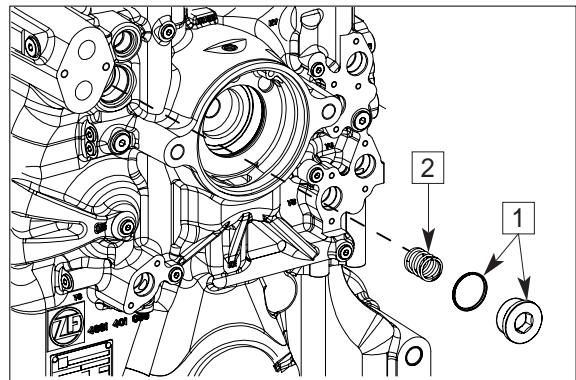

- ③ **Functional check of valve.**

- ※ Use a screwdriver to check the movability of the ball in the valve.

If the valve is o.k., it does not need to be removed.

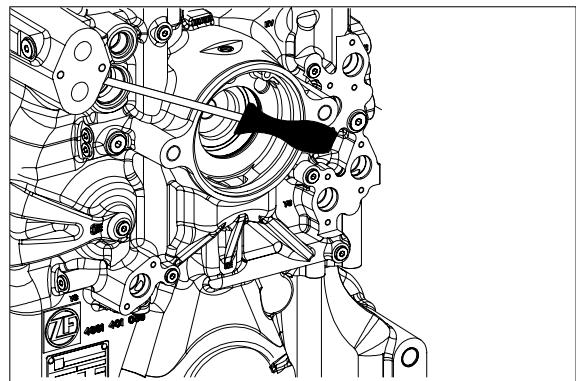

6) REMOVAL OF CLUTCHES AND DISASSEMBLY OF OIL PRESSURE PUMP

- ① Force out cylindrical pins(1).
 - ② Loosen bolted connection(2) of housing front and rear part.
- ▲ Make sure to leave 2 cylindrical screws crosswise in the bolted connection(2). Transmission rear part is not fixed to the clamping angle and could get loose when turning.

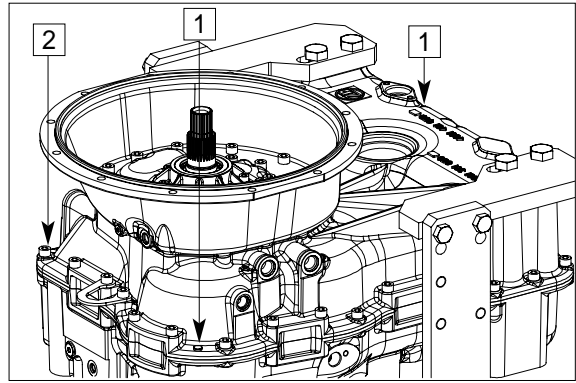

50DS7ETM35

- ③ Rotate transmission housing 180°, loosen the last 2 cylindrical screws from the bolted connection housing front and rear part and separate housing rear part by means of lifting device.

※ Support by means of assembly lever.

(S) Assembly lever 5870 345 036

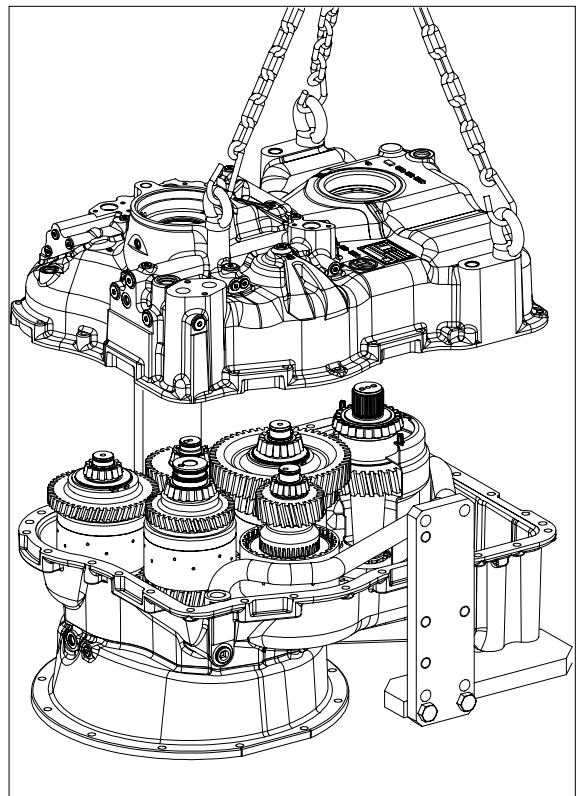

50DS7ETM36

- ④ Lift the clutches out of the housing in the following sequence:

- 1 = Clutch KE (Clutch-3rd gear)
- 2 = Clutch KV (Clutch-forward)
- 3 = Clutch KR (Clutch-reverse and input)
- 4 = Clutch KD (Clutch-2nd gear)
- 5 = Clutch KC (Clutch-1st gear)
- 6 = Output with screen sheet

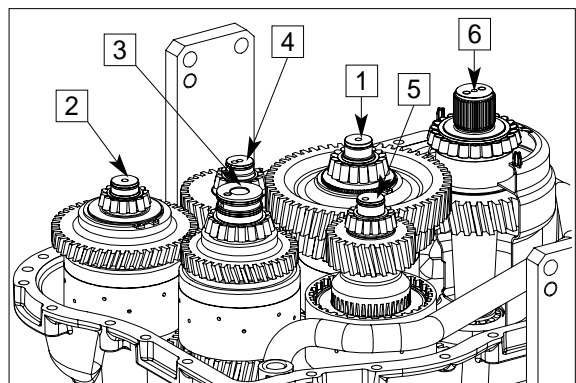

50DS7ETM37

⑤ Use assembly lever to remove all bearing outer rings from the housing front part.

※ If, contrary to the ZF recommendation, the tapered roller bearings of clutches and output are not replaced, it is imperative to ensure the previous pairing (bearing outer ring/bearing inner ring).

※ Bearing outer ring and bearing inner ring must be marked.

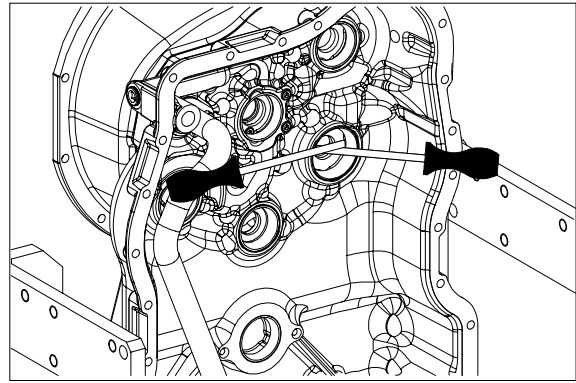

50DS7ETM38

⑥ Use assembly lever to remove all bearing outer rings from the housing rear part.

※ If, contrary to the ZF recommendation, the tapered roller bearings of clutches and output are not replaced, it is imperative to ensure the previous pairing (bearing outer ring/bearing inner ring).

※ Bearing outer ring and bearing inner ring must be marked.

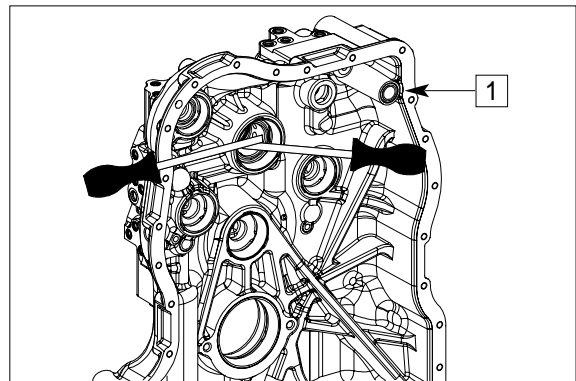

50DS7ETM39

⑦ Remove O-ring(1).

⑧ Loosen cylindrical screws(1) and remove suction tube(2).

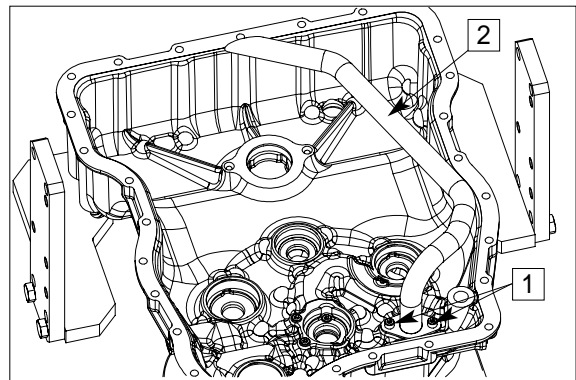

50DS7ETM40

⑨ Loosen cylindrical screws (1).

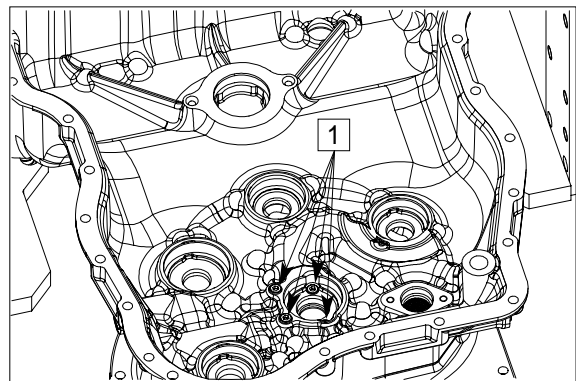

50DS7ETM41

- ⑩ Loosen bolted connection between converter bellhousing/transmission housing(1) and pressure oil pump/transmission housing(2).

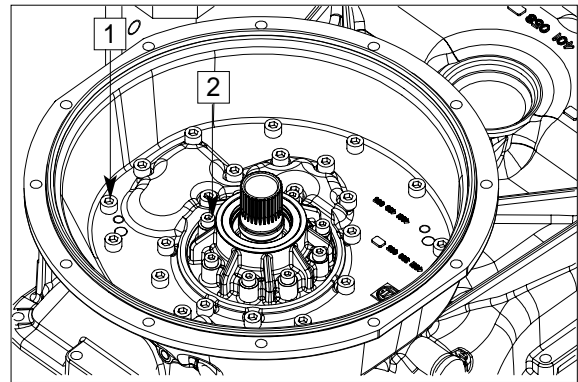

50DS7ETM42

- ⑪ Press converter bellhousing off the housing equally by means of hexagon screws M10(1).

※ Difficult disassembly due to fixing by cylindrical pins.

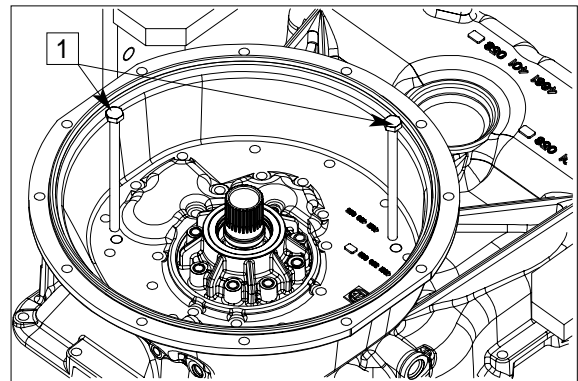

50DS7ETM43

- ⑫ If required, remove both cylindrical pins (1).

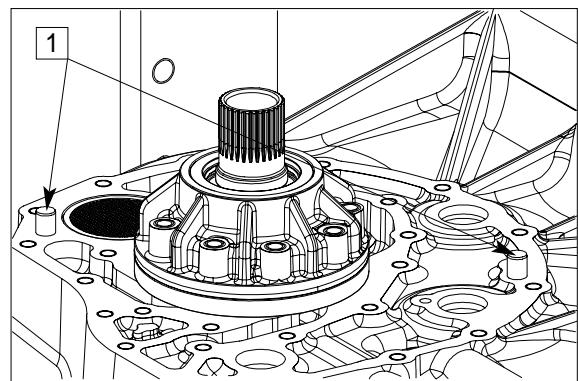

50DS7ETM44

- ⑬ Remove oil pressure pump(1).

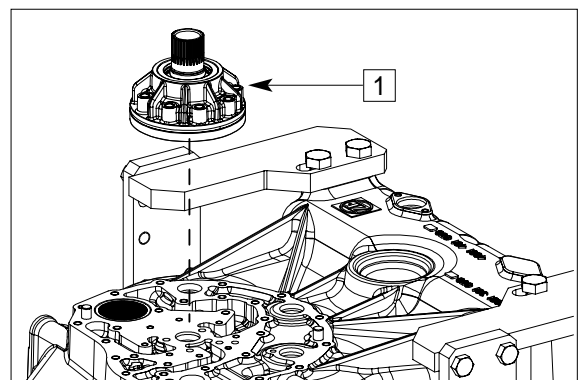

50DS7ETM45

⑭ Remove filter(1).

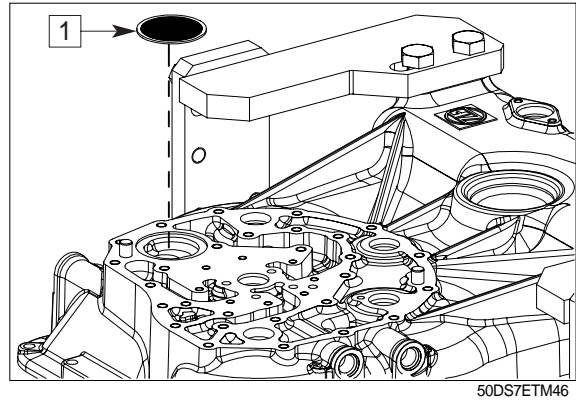

⑮ Remove O-ring(1).

⑯ Loosen cylindrical screws(2).

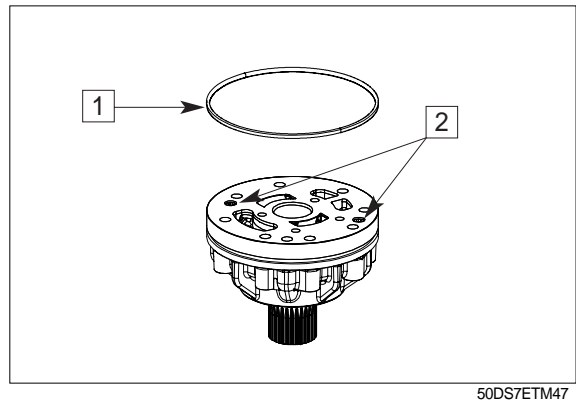

※ Check oil pressure pump :

In case of wear marks in the pump housing, stator hollow shaft or on the inner and outer rotor, the complete oil pressure pump is to be replaced.

1 = Stator hollow shaft

2 = Inner rotor

3 = Outer rotor

4 = Pump housing

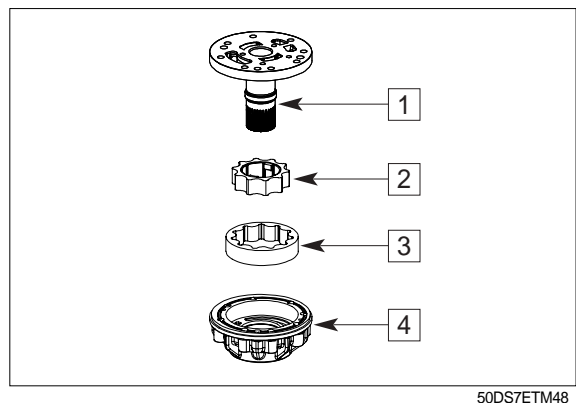

⑰ Remove shaft seal(1) from the pump housing(2).

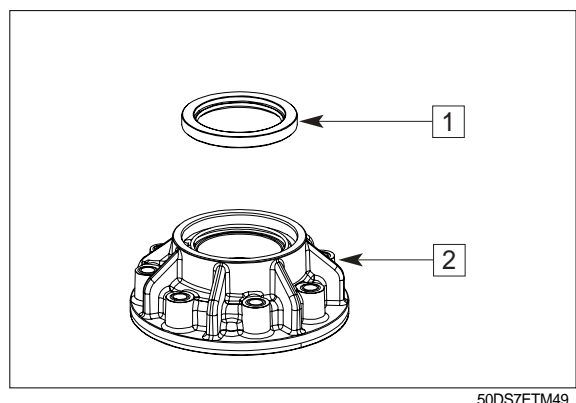

7) DISASSEMBLY CLUTCHES :

- 1 = Clutch KV(Clutch-forward)
- 2 = Clutch KR(Clutch-reverse and input)
- 3 = Clutch KD(Clutch-2nd gear)
- 4 = Clutch KE(Clutch-3rd gear)
- 5 = Clutch KC(Clutch-1st gear)
- 6 = Output

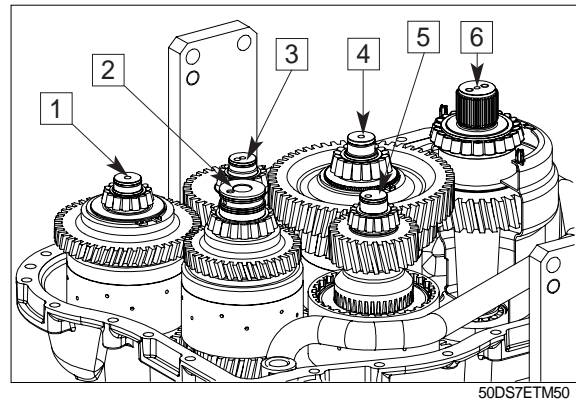

(1) Clutch KR/input

- ① Disengage rectangular ring(1).

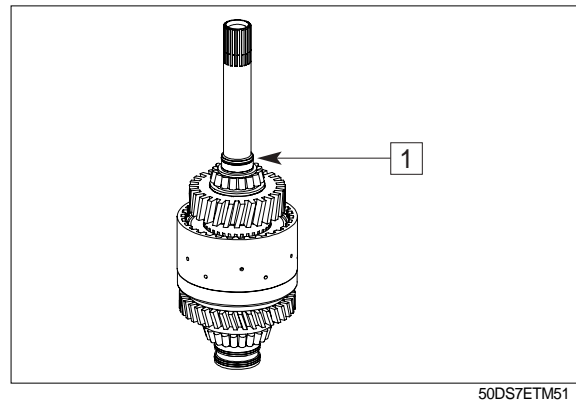

- ② Pull off bearing inner ring with inner disk carrier(1).

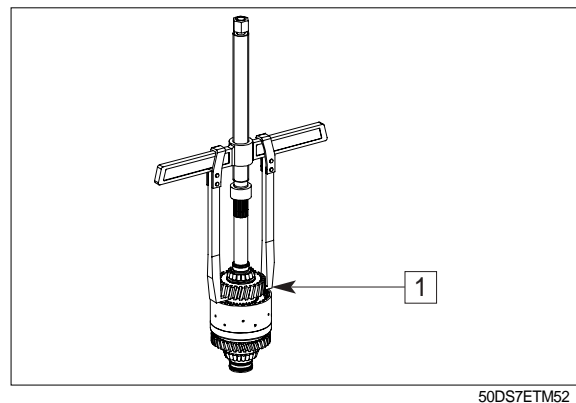

- ③ Remove bearing inner ring(1), axial bearing assy(2) and inner disk carrier (3).

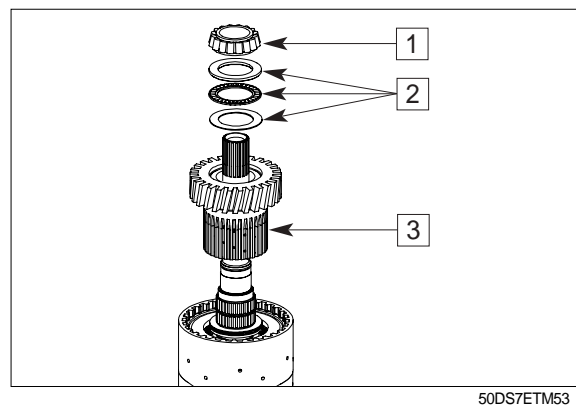

④ Remove needle cage(1).

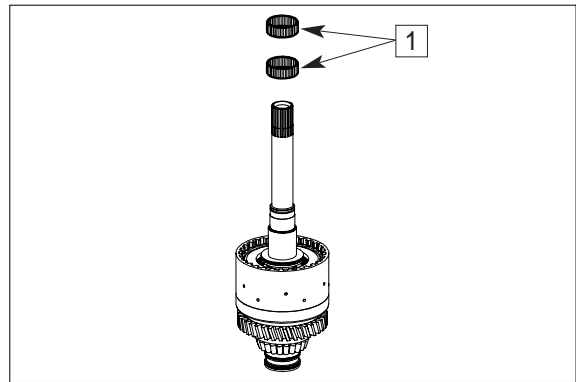

50DS7ETM54

⑤ Remove axial bearing assy(1).

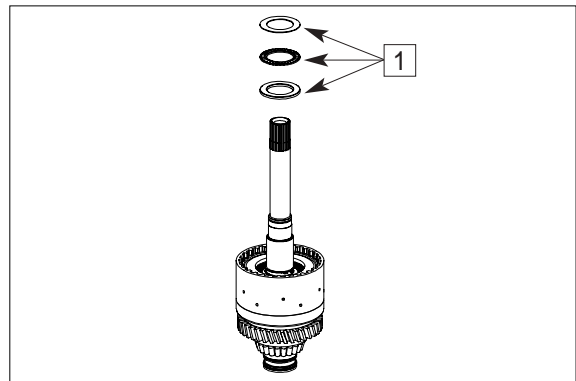

50DS7ETM55

⑥ Disengage snap ring(1).

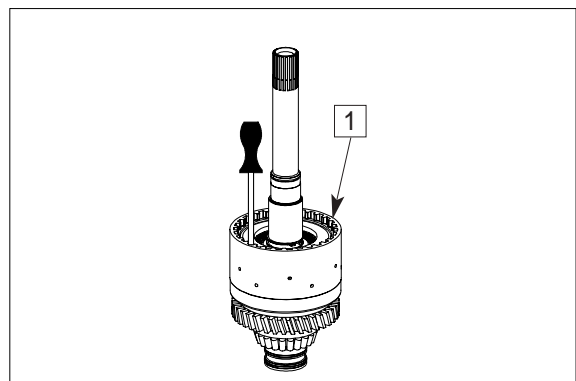

50DS7ETM56

⑦ Remove end plate(1), disk package(2) and plate with cup springs(3) from the disk carrier.

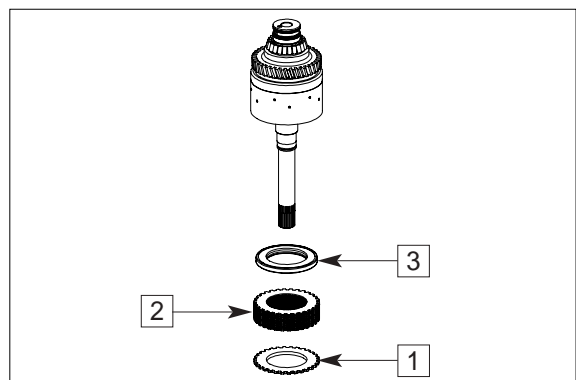

50DS7ETM57

- ⑧ Remove retaining ring-contact position of axial bearing(1).

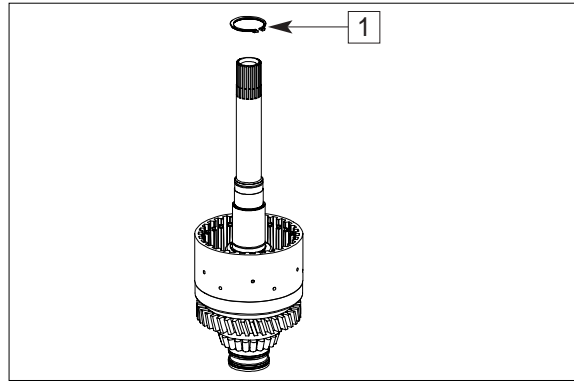

50DS7ETM58

- ⑨ Preload compression spring and disengage retaining ring(1).

(S) Assembly aid 5870 345 114

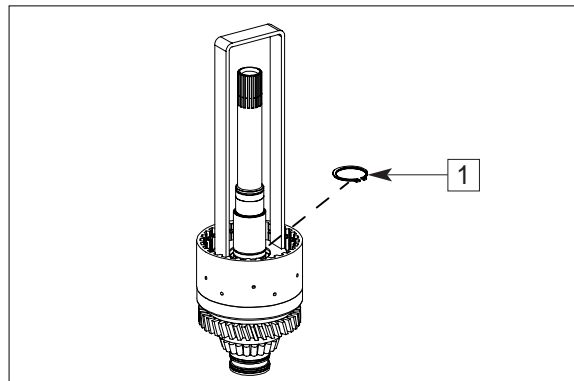

50DS7ETM59

- ⑩ Remove cup spring(1) and compression spring(2).

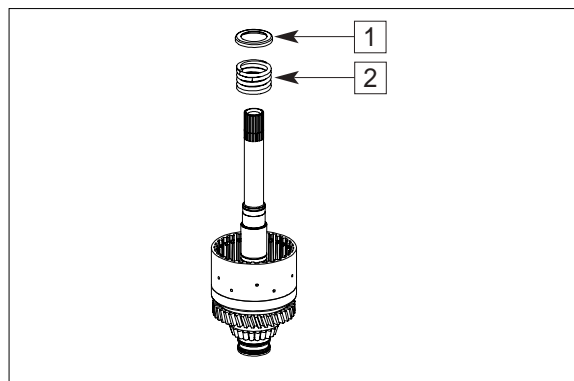

50DS7ETM60

- ⑪ By means of compressed air(see arrow), press piston(1) off the shaft/disk carrier (see arrow) and remove it.

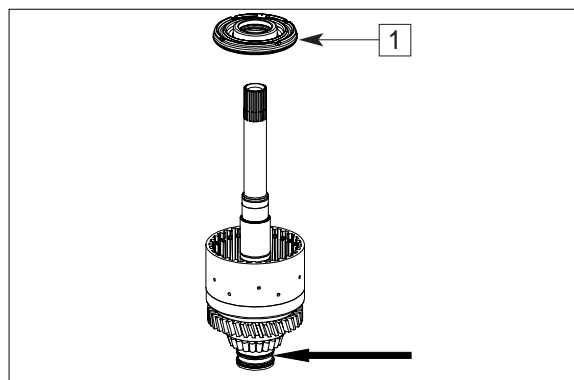

50DS7ETM61

⑫ Remove both O-rings(1 and 2).

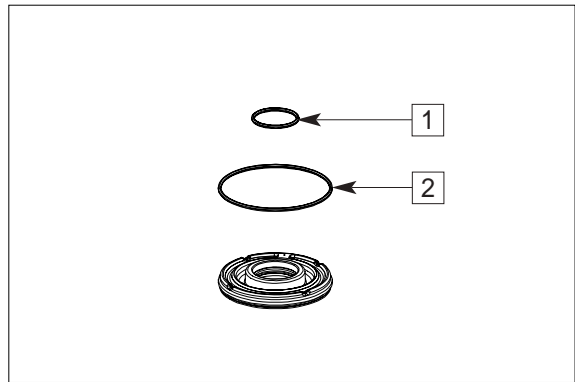

50DS7ETM62

⑬ Disengage rectangular rings(1).

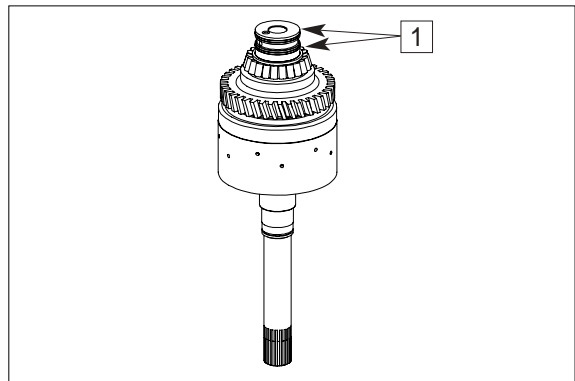

50DS7ETM63

⑭ Pull tapered roller bearing(inner ring) off the shaft.

(S) Grab sleeve 5873 001 026

(S) Basic tool 5873 001 000

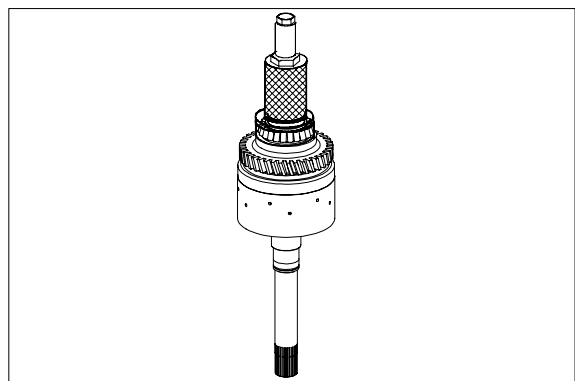

50DS7ETM64

※ The clutch(1) cannot be disassembled.
It is supplied by the spare parts service only as a complete assy which consists of :

1A = Ball

1B = Helical gear

1C = Disk carrier

1D = Input shaft

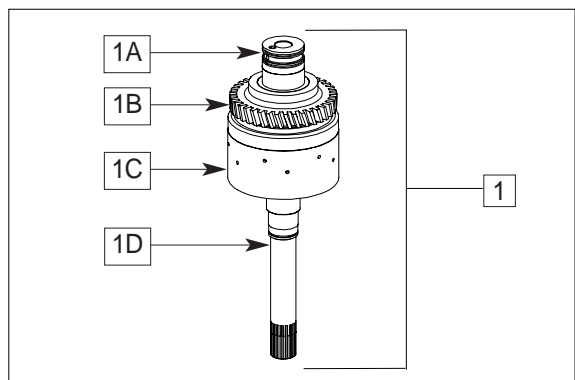

50DS7ETM65

(2) Clutch KV

① Snap out rectangular ring(1).

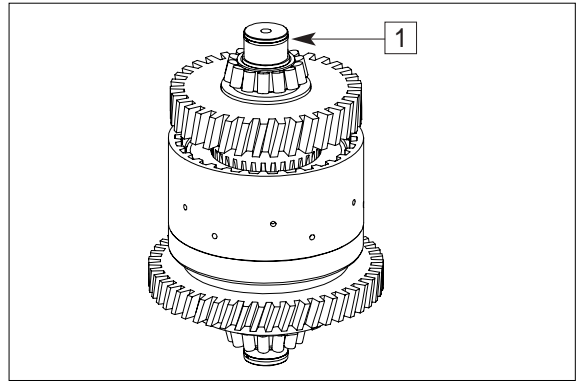

② Pull off bearing inner ring with inner disk carrier(1).

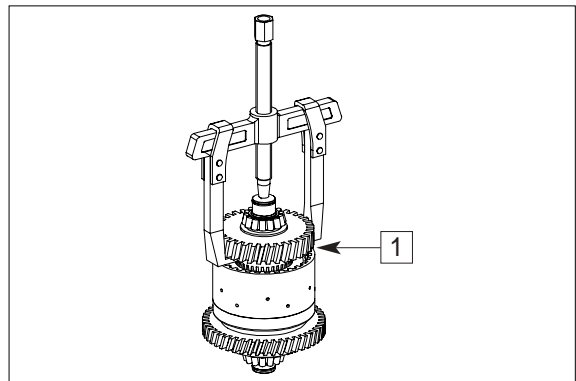

③ Remove bearing inner ring(1), axial bearing assy(2) and inner disk carrier(3).

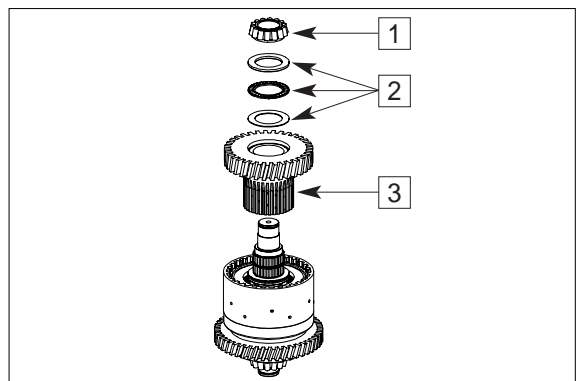

④ Remove needle cage(1).

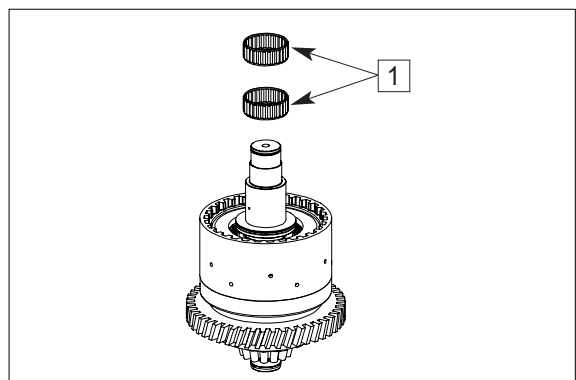

⑤ Remove axial bearing assy(1).

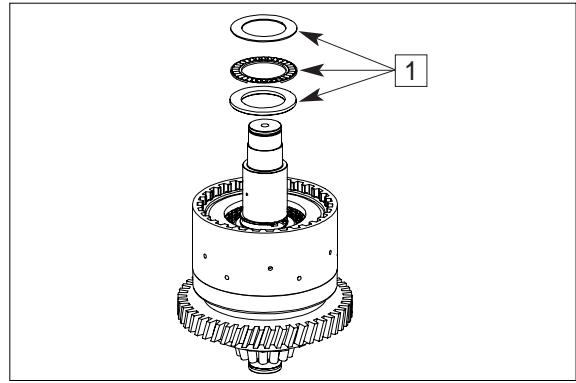

50DS7ETM70

⑥ Remove snap ring(1).

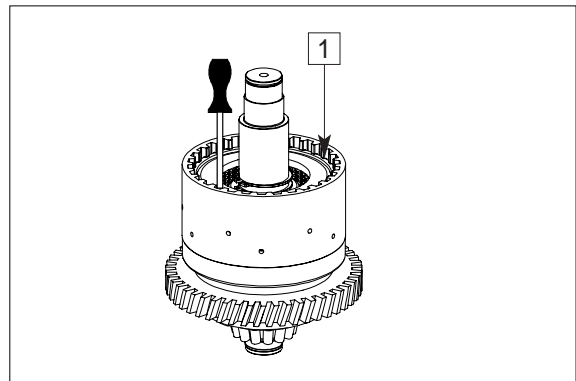

50DS7ETM71

⑦ Remove end plate(1), disk package(2) and plate(3) from the disk carrier.

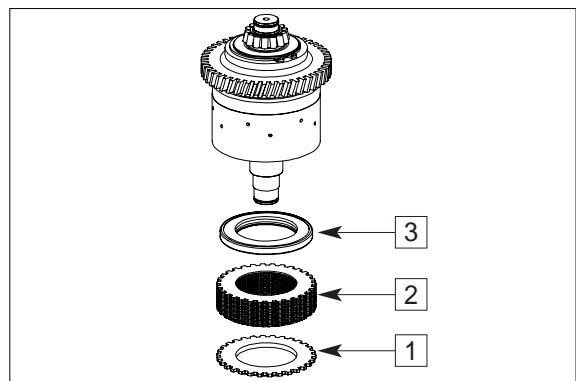

50DS7ETM72

⑧ Remove retaining ring-contact position of axial bearing(1).

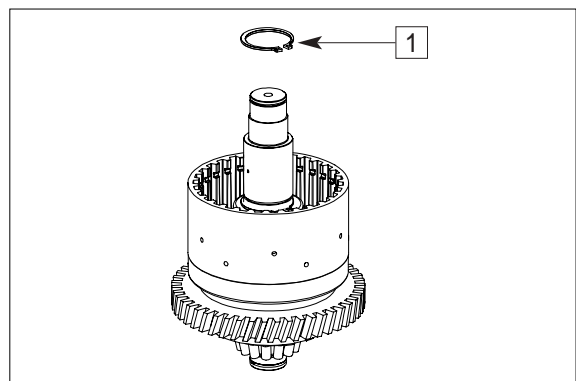

50DS7ETM73

- ⑨ Preload compression spring and remove retaining ring(1).

(S) Assembly aid 5870 345 114

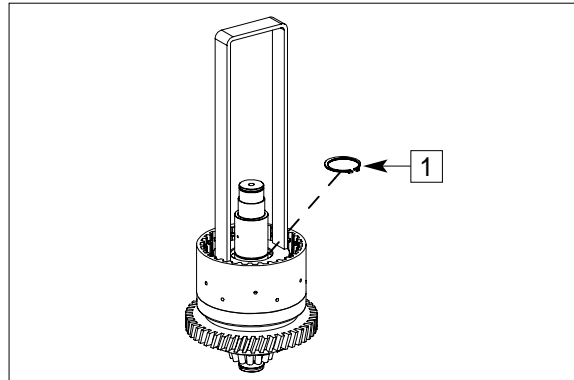

50DS7ETM74

- ⑩ Remove cup spring(1) and compression spring(2).

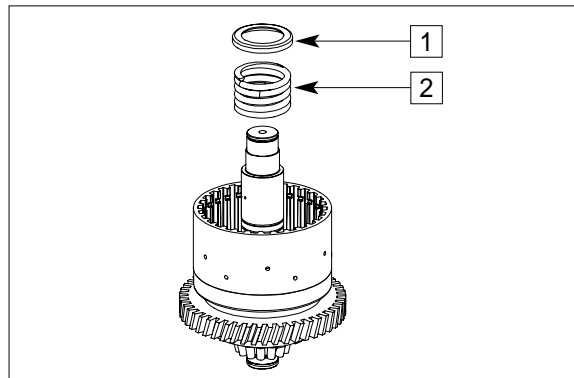

50DS7ETM75

- ⑪ By means of compressed air(see arrow), press piston(1) off the shaft/disk carrier and remove it.

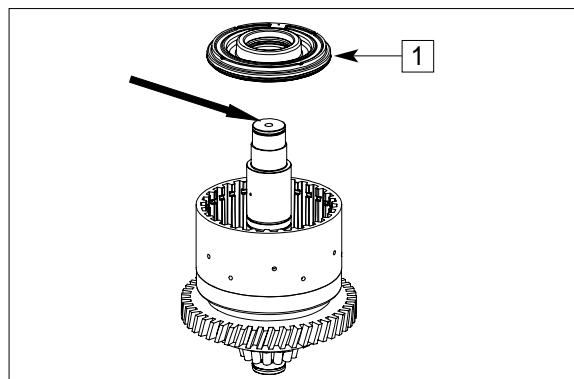

50DS7ETM76

- ⑫ Remove both O-rings(1 and 2).

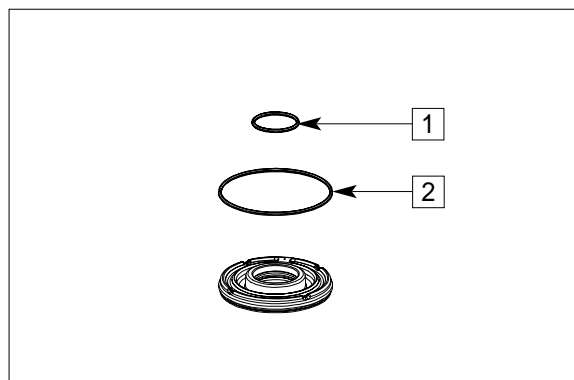

50DS7ETM62

⑬ Snap out rectangular ring(1).

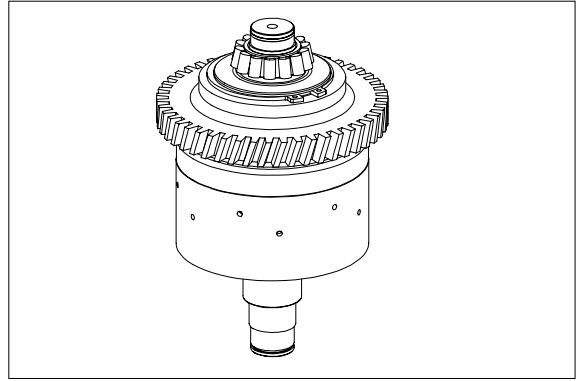

50DS7ETM78

⑭ Pull tapered roller bearing(inner ring) off the shaft.

(S) Grab sleeve 5873 000 029

(S) Basic tool 5873 000 000

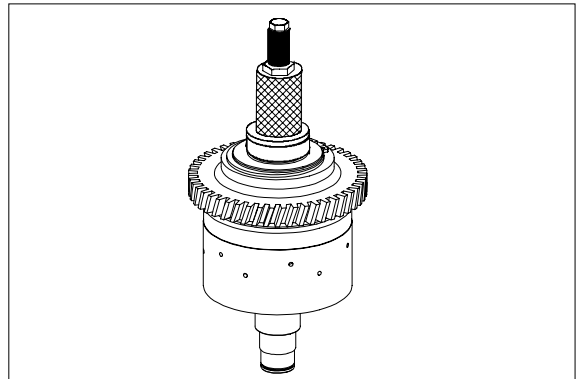

50DS7ETM79

※ The clutch(1) cannot be disassembled.
It is supplied by the spare parts service only as a complete assy which consists of :

1A = Retaining ring

1B = Helical gear

1C = Disk carrier

1D = Shaft

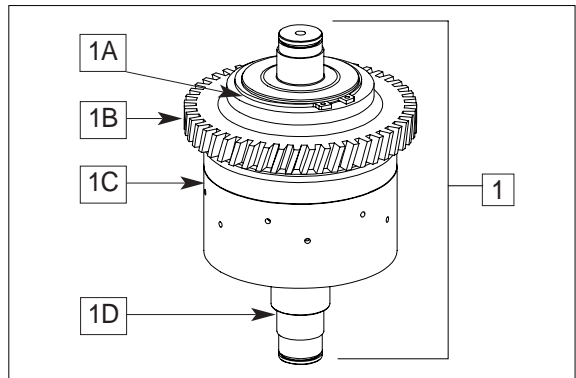

50DS7ETM80

(3) Clutch KD

① Snap out rectangular ring(1).

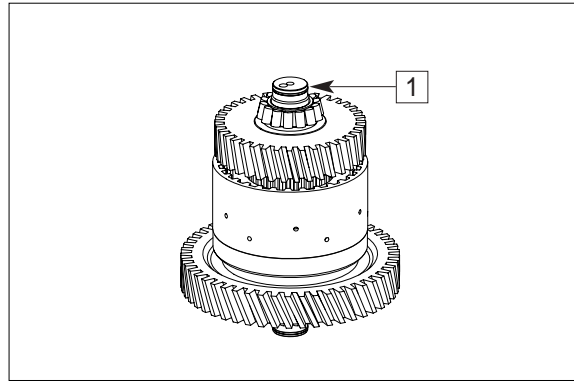

50DS7ETM81

② Pull tapered roller bearing(inner ring) off the shaft.

(S) Grab sleeve 5873 000 029

(S) Basic tool 5873 000 000

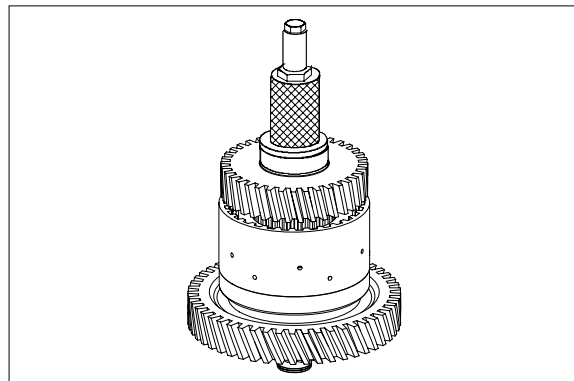

50DS7ETM82

③ Remove axial bearing assy(1) and inner disk carrier.

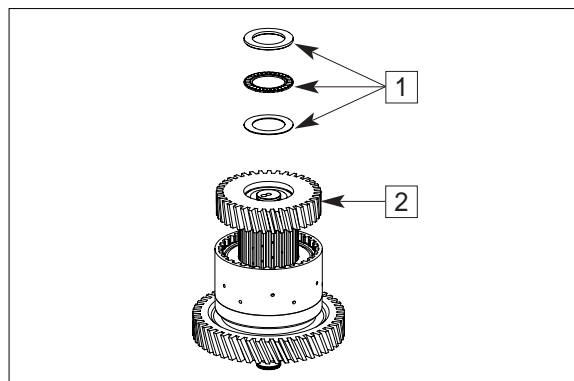

50DS7ETM83

④ Remove needle cage(1).

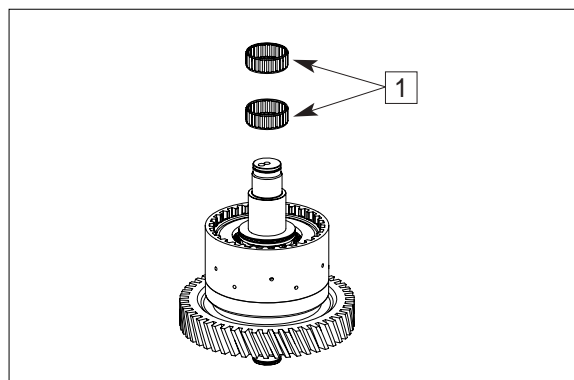

50DS7ETM84

⑤ Remove axial bearing assy(1).

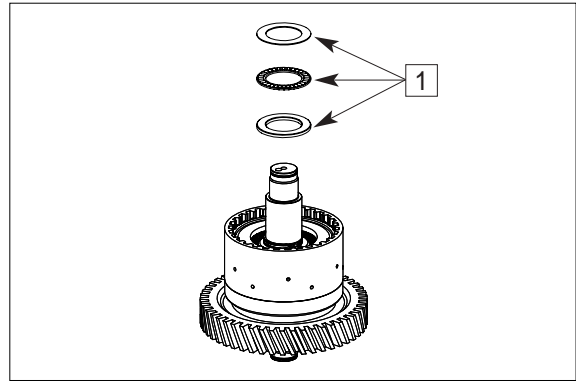

⑥ Remove snap ring(1).

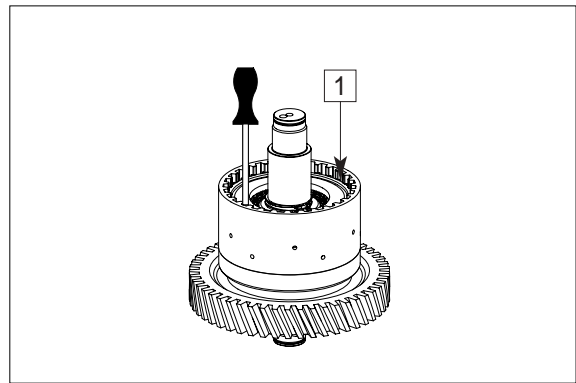

⑦ Remove end plate(1), disk package(2) and cup spring(3) from the disk carrier.

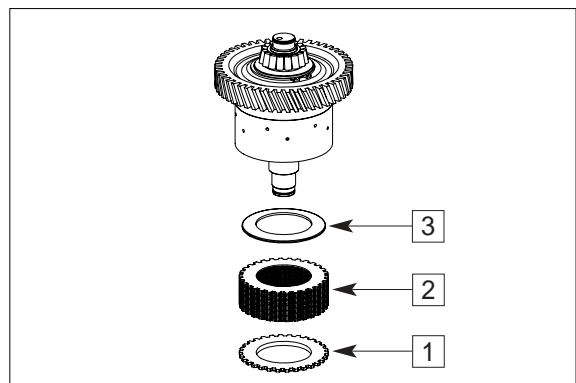

⑧ Remove retaining ring-contact position of axial bearing(1).

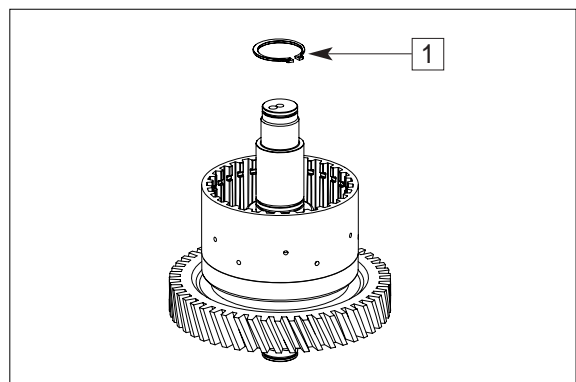

- ⑨ Preload compression spring and remove snap ring(1).

(S) Assembly aid 5870 345 114

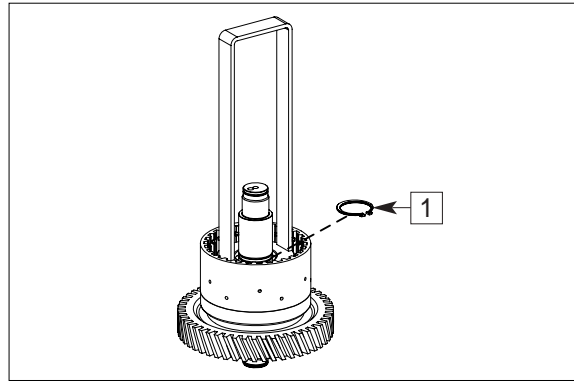

50DS7ETM89

- ⑩ Remove spring cup(1) and compression spring(2).

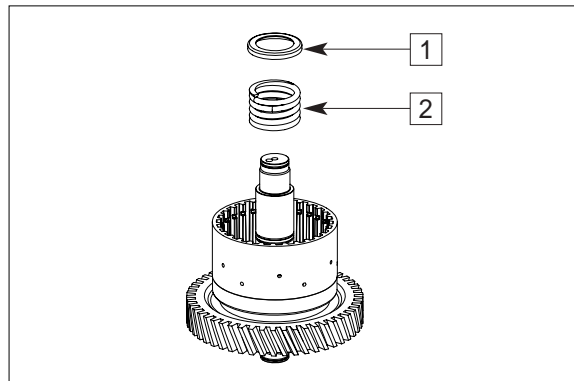

50DS7ETM90

- ⑪ By means of compressed air(see arrow), press piston(1) off the shaft/disk carrier and remove it.

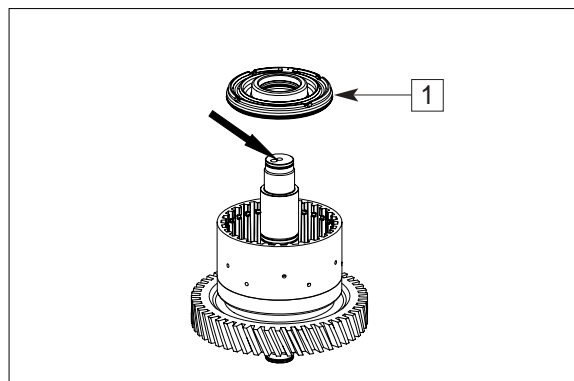

50DS7ETM91

- ⑫ Remove both O-rings(1 and 2).

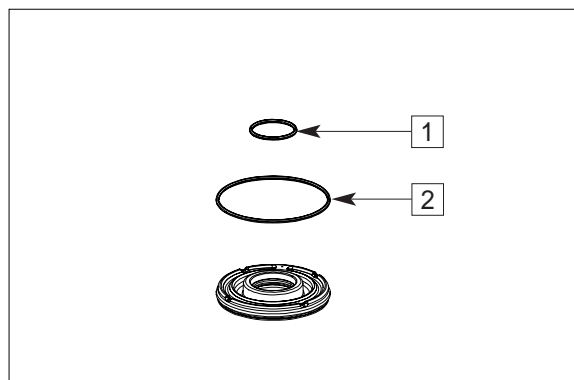

50DS7ETM62

⑬ Snap out rectangular ring(1).

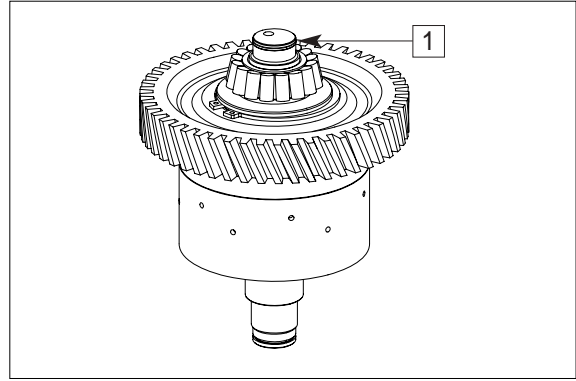

50DS7ETM93

⑭ Pull tapered roller bearing(inner ring) off the shaft.

(S) Rapid grip 5873 011 011

(S) Extractor set 5870 026 100

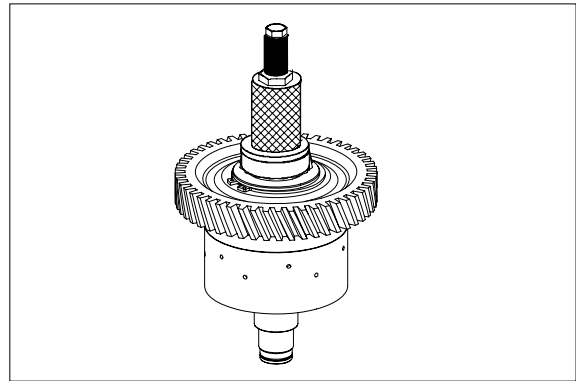

50DS7ETM94

※ The clutch(1) cannot be disassembled.
It is supplied by the spare parts service only as a complete assy which consists of :

1A = Retaining ring

1B = Helical gear

1C = Disk carrier

1D = Shaft

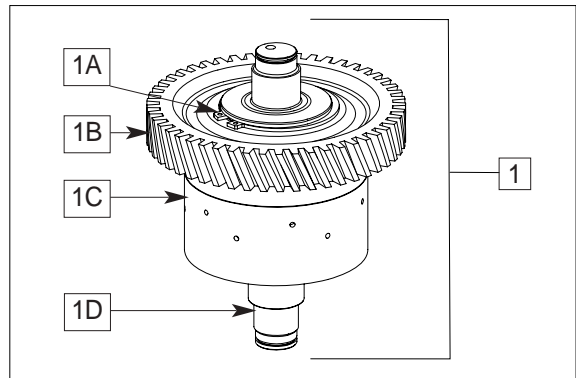

50DS7ETM95

(4) Clutch KE

① Snap out rectangular ring(1).

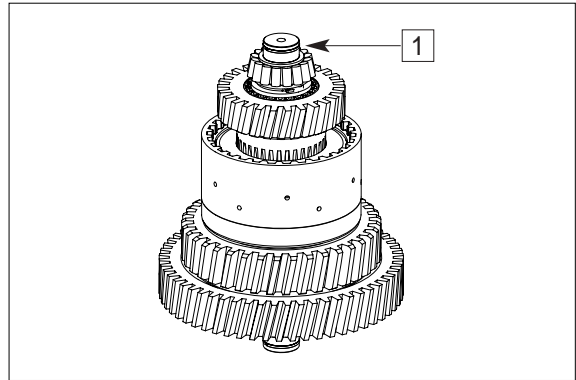

50DS7ETM96

② Pull tapered roller bearing(inner ring) off the shaft.

(S) Grab sleeve 5873 000 029

(S) Basic tool 5873 001 000

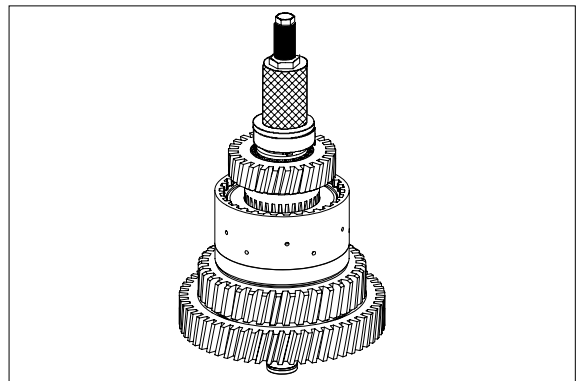

50DS7ETM97

③ Remove retaining ring(1).

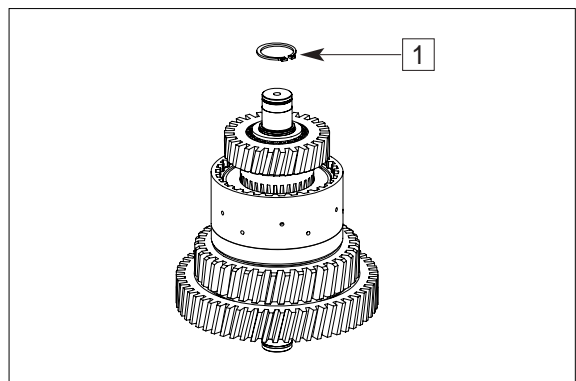

50DS7ETM98

④ Remove bearing inner ring(1) and inner disk carrier(2).

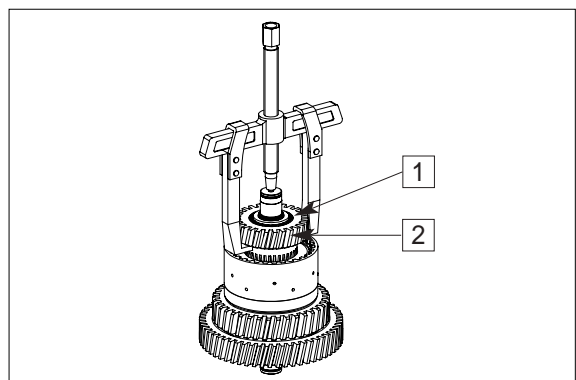

50DS7ETM99

- ⑤ Remove tapered roller bearing(1) and inner disk carrier(2).

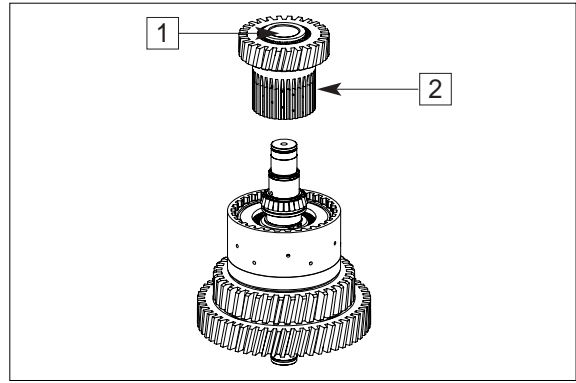

50DS7ETM100

- ⑥ Pull off bearing inner ring(1) and running disk(2).

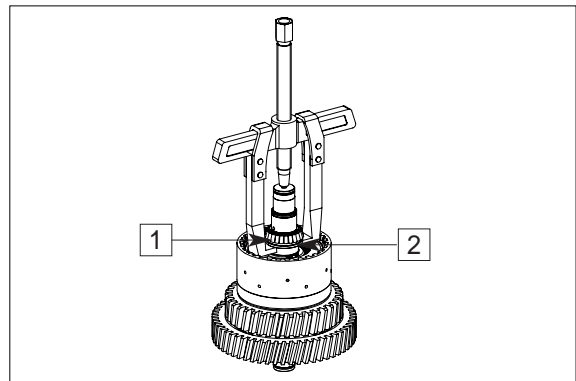

50DS7ETM101

- ⑦ Remove bearing inner ring(1) and running disk(2).

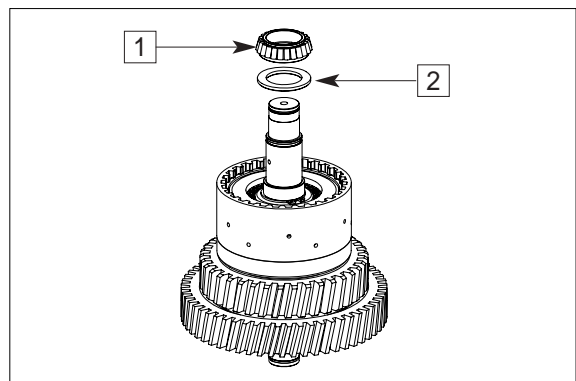

50DS7ETM102

- ⑧ Disengage snap ring(1).

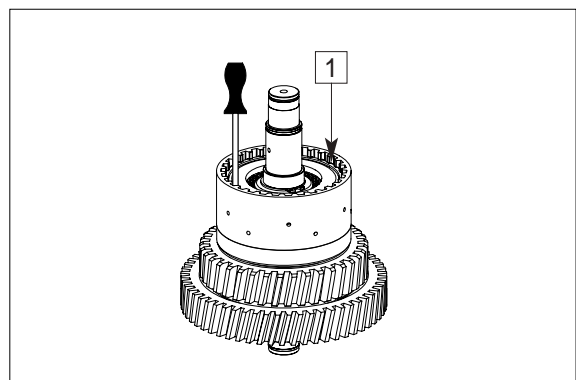

50DS7ETM103

- ⑨ Remove end plate(1), disk package(2) and cup spring(3) from the disk carrier.

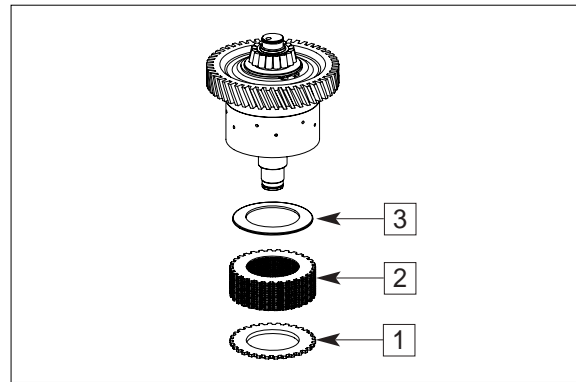

50DS7ETM104

- ⑩ Preload compression spring and remove snap ring(1).

(S) Assembly aid 5870 345 114

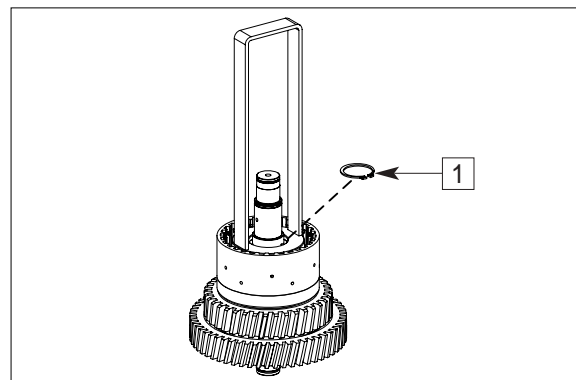

50DS7ETM105

- ⑪ Remove spring cup(1) and compression spring(2).

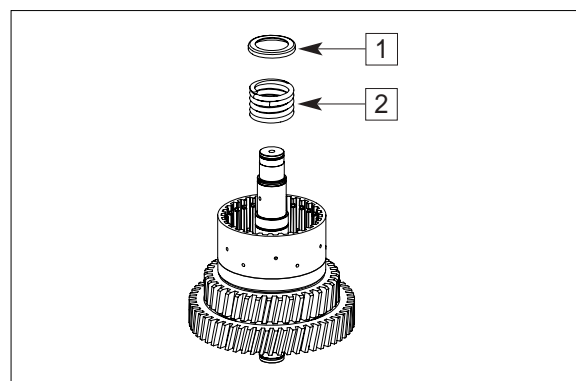

50DS7ETM106

- ⑫ By means of compressed air(see arrow), press piston(1) off the shaft/disk carrier and remove it.

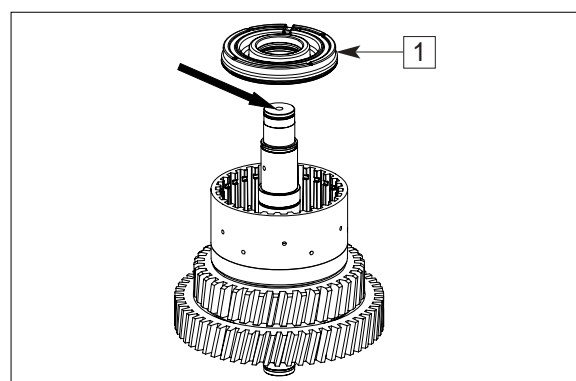

50DS7ETM107

⑬ Remove both O-rings(1 and 2).

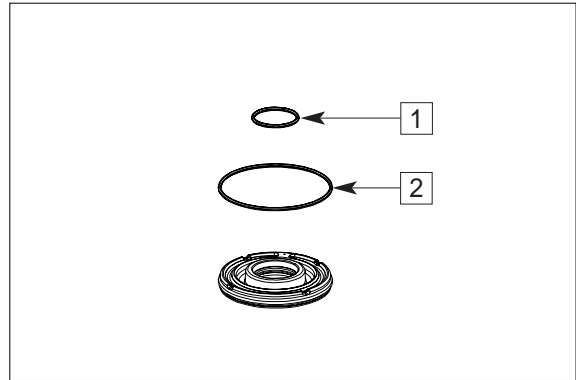

50DS7ETM62

⑭ Snap out rectangular ring(1).

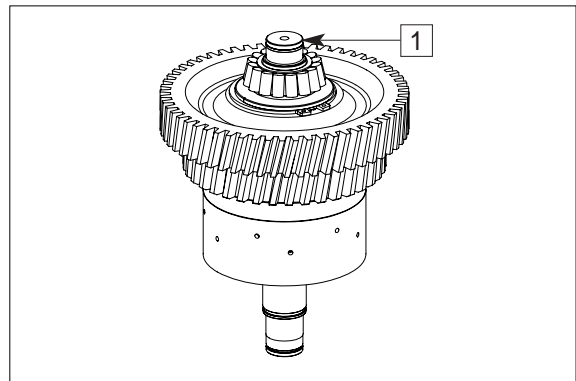

50DS7ETM109

⑮ Pull tapered roller bearing(inner ring) off the shaft.

(S) Rapid grip 5873 011 011
 (S) Basic tool 5873 001 000

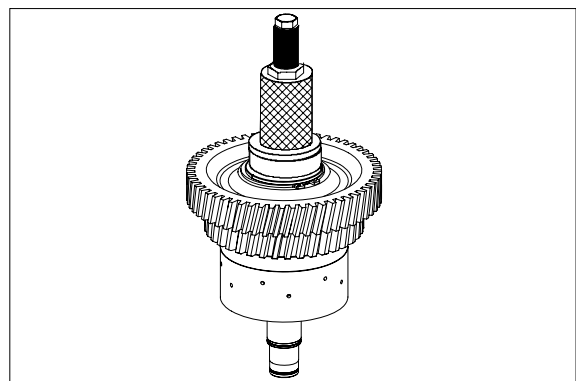

50DS7ETM110

※ The clutch(1) cannot be disassembled.
 It is supplied by the spare parts service only as a complete assy which consists of :

1A = Retaining ring
 1B = Helical gears
 1C = Disk carrier
 1D = Shaft

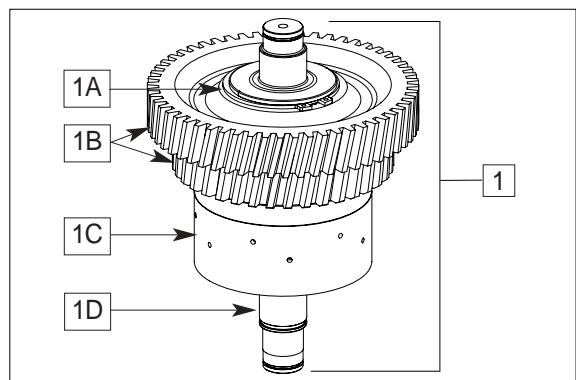

50DS7ETM111

(5) Clutch KC

① Snap out rectangular ring(1).

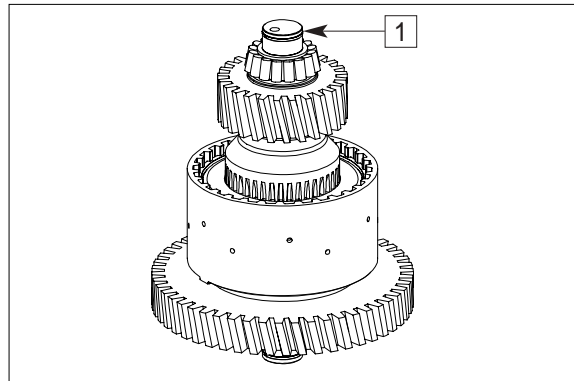

50DS7ETM112

② Pull off bearing inner ring with inner disk carrier(1).

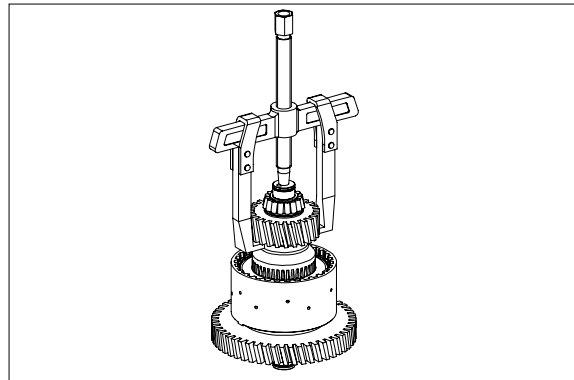

50DS7ETM113

③ Remove bearing inner ring(1), axial bearing assy(2) and inner disk carrier (3).

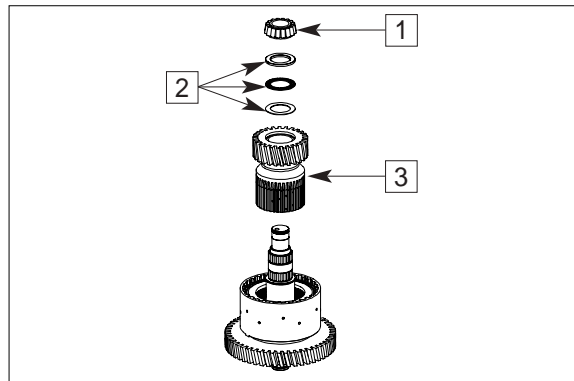

50DS7ETM114

④ Remove needle cage(1) and bush(2).

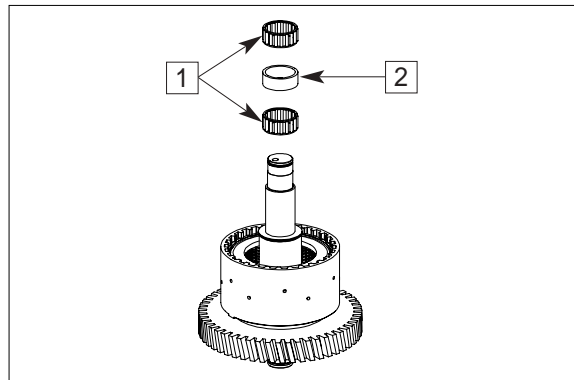

50DS7ETM115

- ⑤ Remove axial disk(1) and axial needle cage(2).

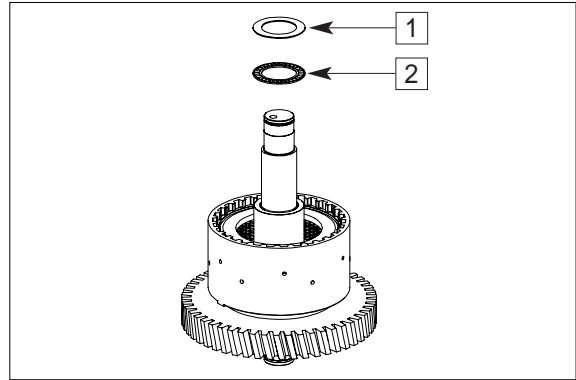

50DS7ETM116

- ⑥ Disengage snap ring(1).

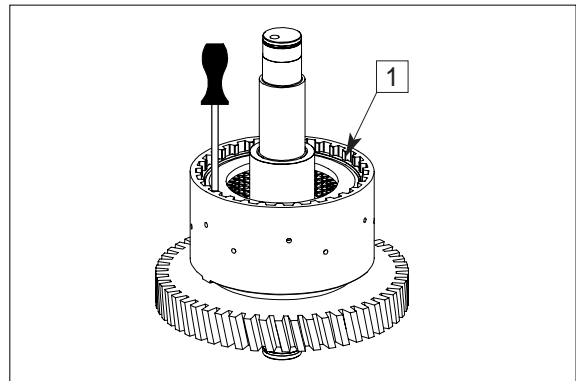

50DS7ETM117

- ⑦ Remove end plate(1) and disk package (2) from the disk carrier.

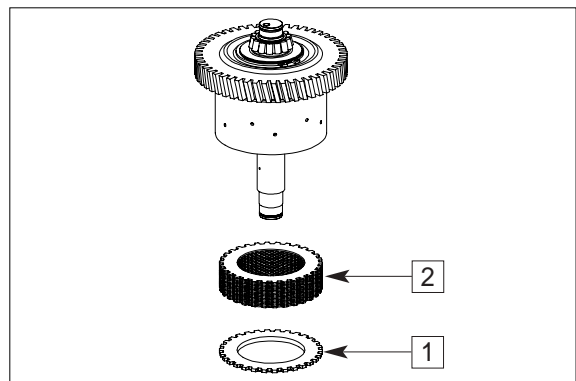

50DS7ETM118

- ⑧ Preload compression springs and remove snap ring(1).

(S) Assembly aid

5870 506 128

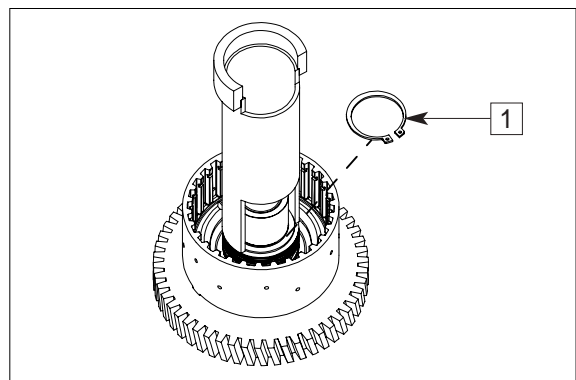

50DS7ETM119

⑨ Remove disk(1) and cup springs(2).

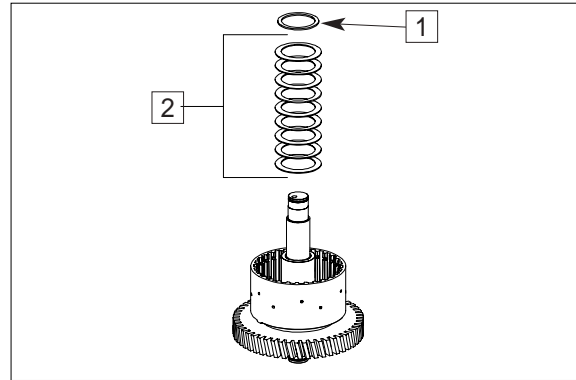

⑩ By means of compressed air(see arrow), press piston(1) off the shaft/disk carrier and remove it.

Remove both O-rings.

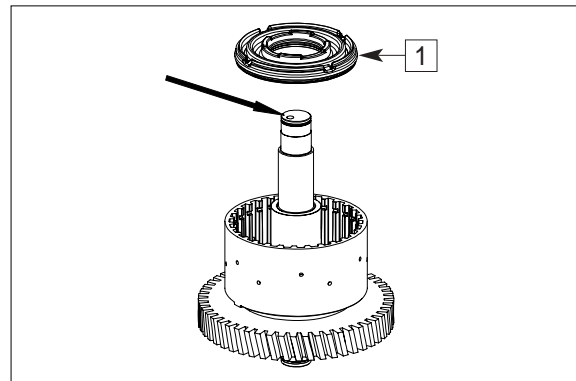

⑪ Snap out rectangular ring(1).

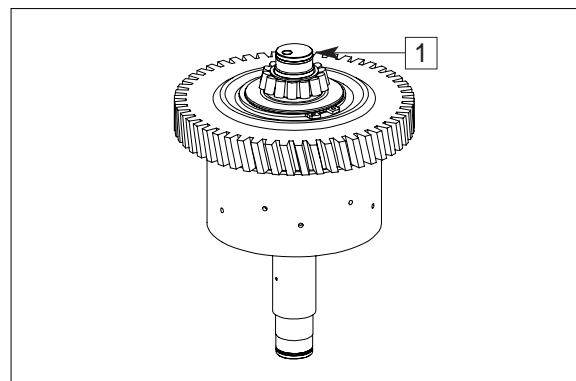

⑫ Pull tapered roller bearing(inner ring) off the shaft.

(S) Grab sleeve 5873 002 029

(S) Basic tool 5873 000 001

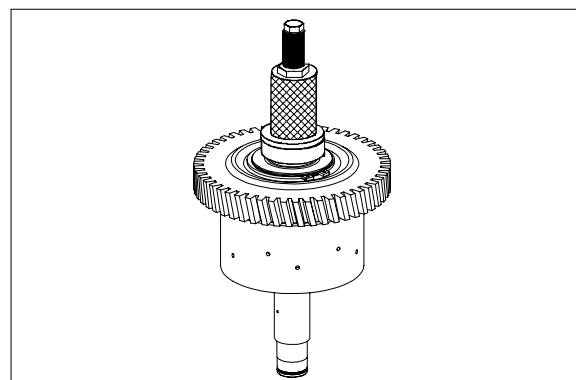

※ The clutch(1) cannot be disassembled.
It is supplied by the spare parts service only as a complete assy which consists of:

1A = Retaining ring

1B = Helical gear

1C = Disk carrier

1D = Shaft

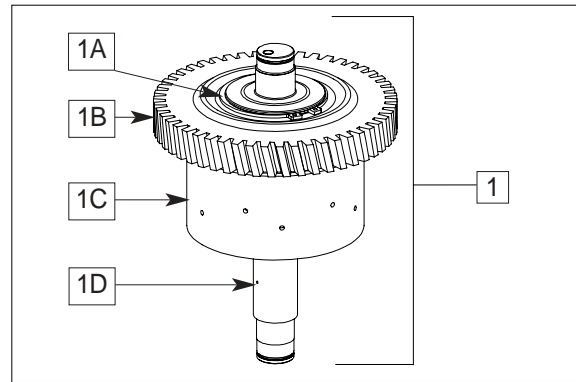

50DS7ETM124

(6) Output shaft

- ① Pull the bearing inner ring off the output shaft.

(S) Grab sleeve 5873 000 029
(S) Basic tool 5873 000 001

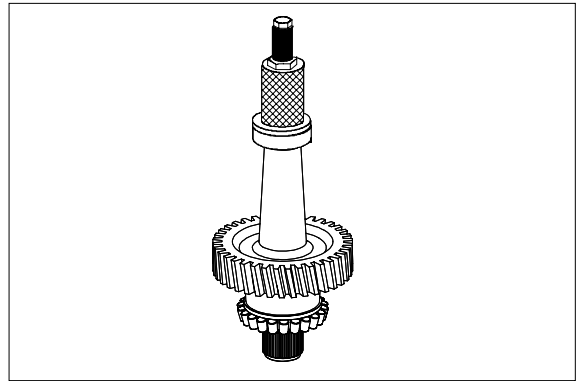

50DS7ETM125

- ② Rotate output shaft 180° and pull off bearing inner ring.

(S) Grab sleeve 5873 002 035
or
(S) Rapid grip 5873 012 011
(S) Basic tool 5873 002 000

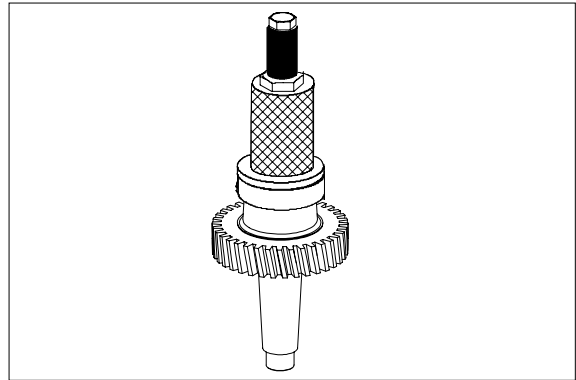

50DS7ETM126

2. TRANSMISSION ASSEMBLY

1) REASSEMBLY OF CLUTCHES :

(1) Clutch KR/input

※ The clutch(1) is supplied by the spare parts service only as a complete assy which consists of:

1A = Ball

1B = Helical gear

1C = Disk carrier

1D = Input shaft

- ① Heat up bearing inner ring(approx. 120°C).

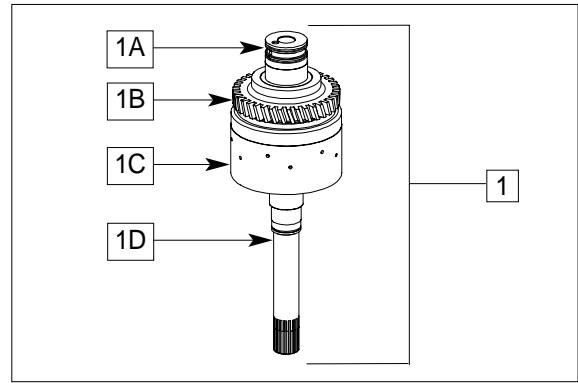

50DS7ETM65

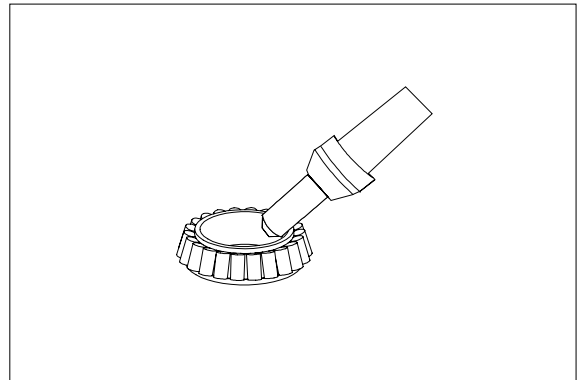

50DS7ETM128

- ② Mount bearing inner ring(1) until contact is obtained.

Fit rectangular rings 50×2.5(2).

▲ Wear protective gloves.

※ Adjust bearing inner ring after cooling-down.

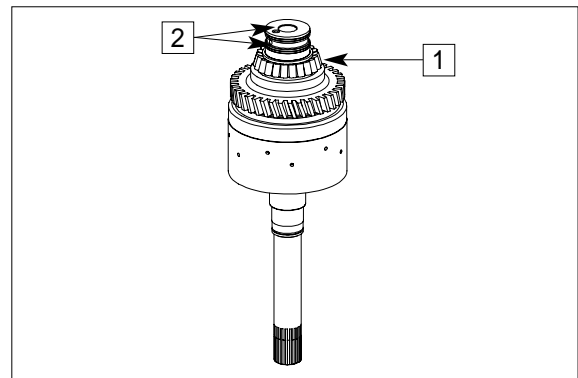

50DS7ETM129

- ③ Insert both O-rings(1 and 2) into the piston grooves and oil them.

1 = 40×3

2 = 104.5×3

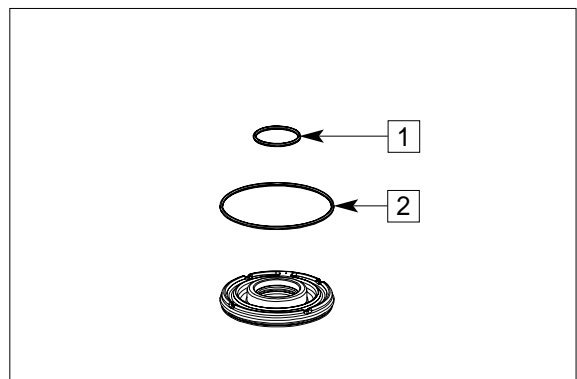

50DS7ETM62

④ Insert piston(1) into the disk carrier.

※ Pay attention to the installation position, see Figure.

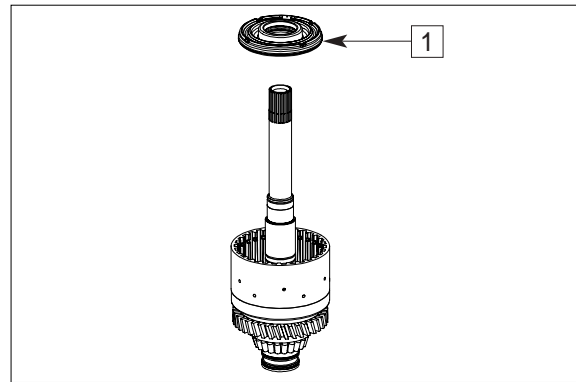

50DS7ETM131

⑤ Use a hand-operated press to place piston into the disk carrier by means of the assembly aid.

(S) Assembly aid 5870 345 114

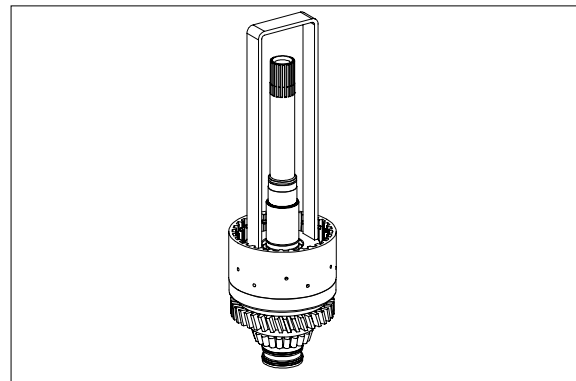

50DS7ETM132

⑥ Mount compression spring(1) and cup spring(2).

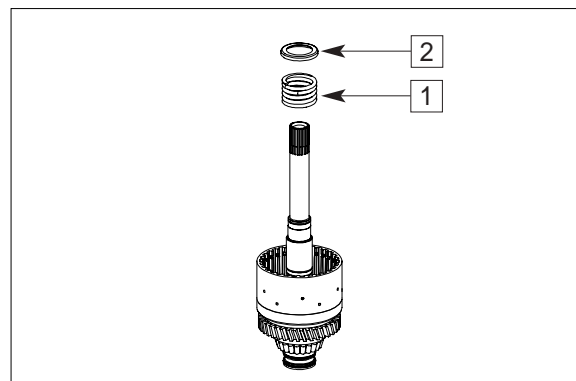

50DS7ETM60

⑦ By means of the assembly aid, preload compression spring under a hand-operated press until the retaining ring 40 × 1.75(1) can be snapped in.

(S) Assembly aid 5870 345 114

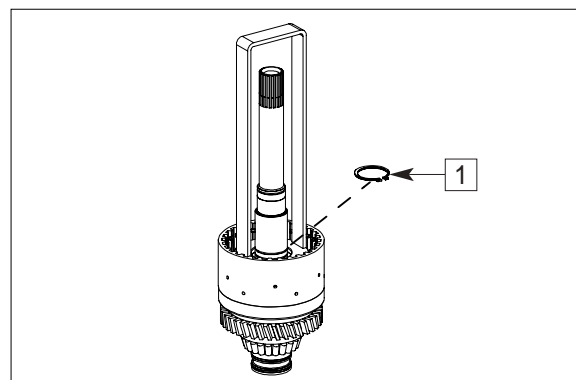

50DS7ETM59

- ⑧ Mount plate assy with cup springs(1), with the open side showing towards the piston(see arrow).

※ Installation position plate-see below figure.

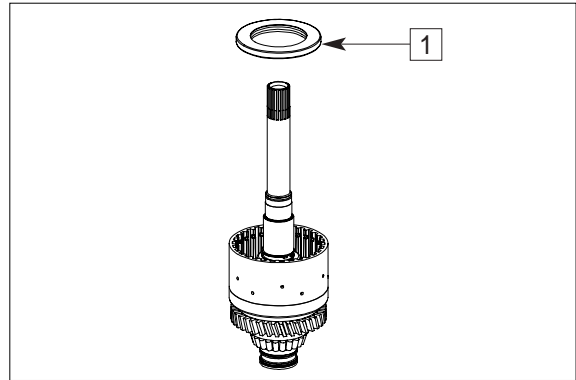

50DS7ETM135

- ⑨ Fit plate(1) according to sketch(see arrow).

- 1 = Plate with cup springs
- 2 = Compression spring with spring cup and retaining ring
- 3 = Piston with O-rings
- 4 = Clutch assy

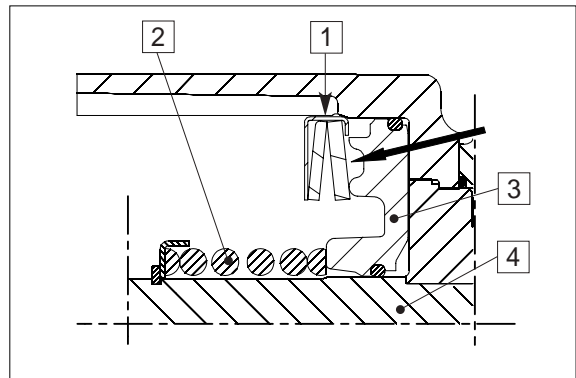

50DS7ETM136

- ⑩ Install outer and inner disks alternately into the disk carrier(3) as shown in figure.

Starting with an outer disk and ending with an inner disk.

- 1 = Outer disks(10 pcs)
- 2 = Inner disks(10 pcs)
- 3 = Clutch assy

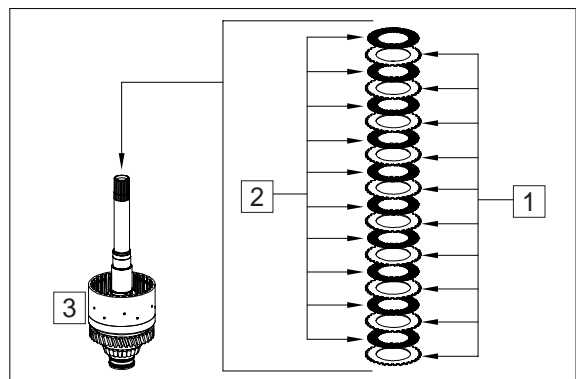

50DS7ETM137

- ⑪ Mount end plate(1) with the flat side showing towards the disk package and fix it by means of snap ring(2)(e.g. thickness=2.5mm/recommended value).

※ Pay attention to the installation position of the end plate.

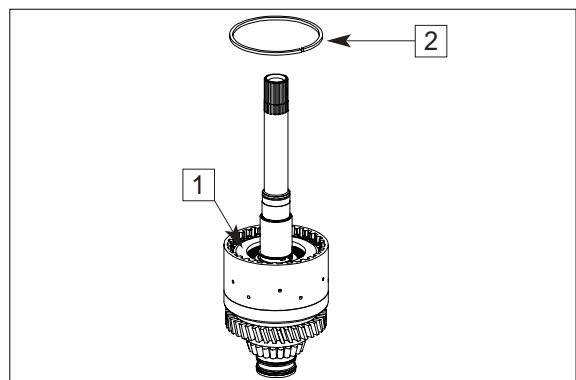

50DS7ETM138

- ⑫ Equally press on end plate with F (approx. 100N = 10kg) and set dial indicator to "zero".

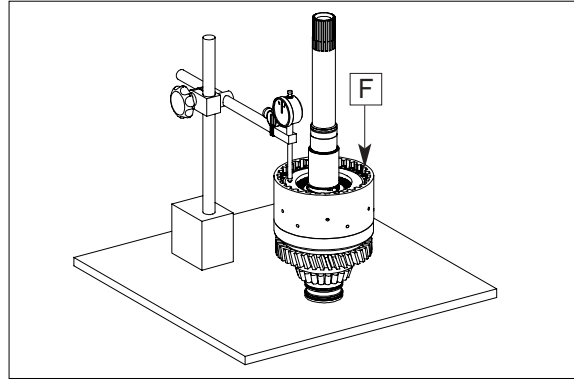

50DS7ETM139

- ⑬ Then press end plate against the snap ring (upwards) and read the disk clearance.

※ Disk clearance : 2.2 to 2.6mm

※ In case of deviations, the disk clearance must be corrected with an appropriate snap ring (optional thickness = 2.0 3.5mm/available in steps of 0.25mm).

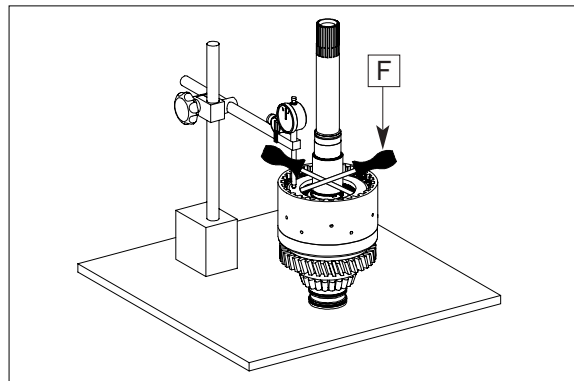

50DS7ETM140

- ⑭ Snap retaining ring $40 \times 1.75(1)$ into the groove.

※ Contact for axial bearing - see below figure.

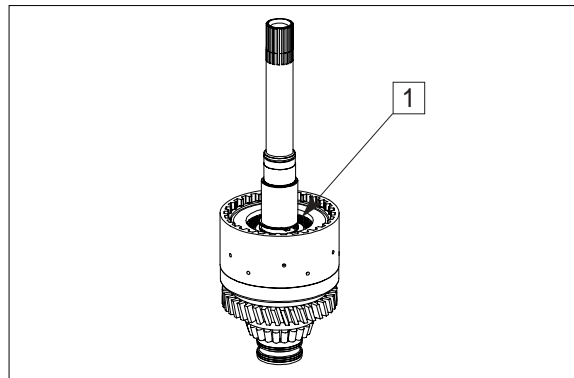

50DS7ETM141

- ⑮ Mount running disk $40 \times 60 \times 3.5(1)$, axial needle cage $40 \times 60 \times 3(2)$ and axial washer $40 \times 60 \times 1(3)$ and oil them.

※ Fit running disk (1), with the chamfer showing towards the retaining ring.

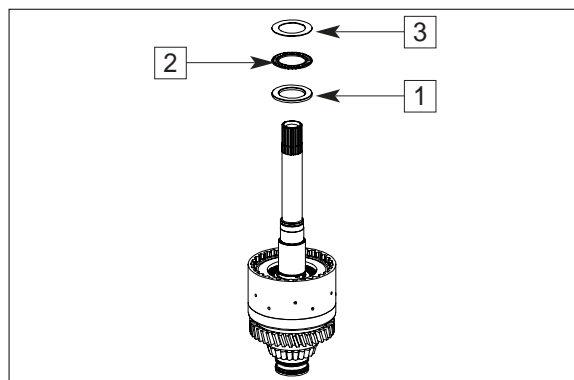

50DS7ETM142

- ⑯ Mount needle cage $40 \times 45 \times 17(1)$ and oil it.

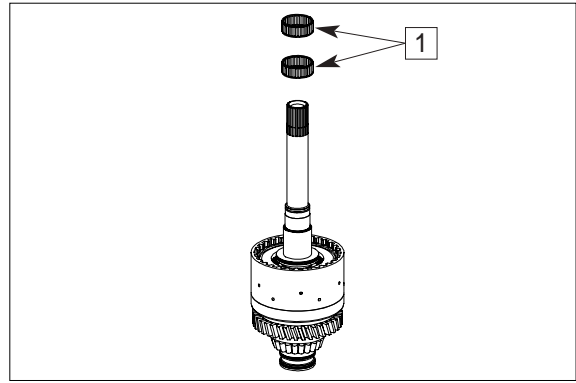

50DS7ETM143

- ⑰ Mount inner disk carrier until contact is obtained.

Install inner disks by short ccw/cw rotations of the inner disk carrier(1).

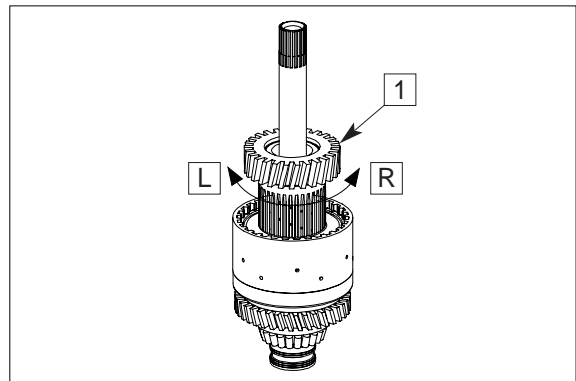

50DS7ETM144

- ⑱ Mount axial washer $40 \times 60 \times 1(1)$, axial needle cage $40 \times 60 \times 3(2)$ and running disk(3) $40 \times 60 \times 3.5$ and oil them.

※ Fit running disk(3), with the chamfer showing towards the tapered roller bearing.

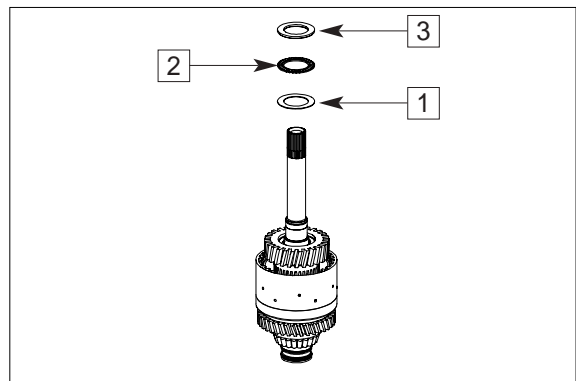

50DS7ETM145

- ⑲ Heat up bearing inner ring(approx. 120°C).

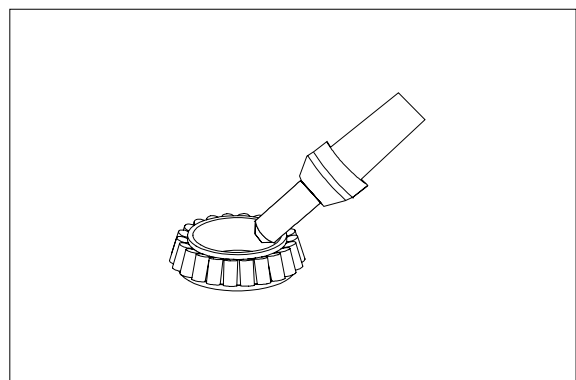

50DS7ETM128

② Mount bearing inner ring(1) until contact is obtained.

Fit rectangular ring 30 × 2(2).

⚠ Wear protective gloves.

※ Adjust bearing inner ring after cooling-down.

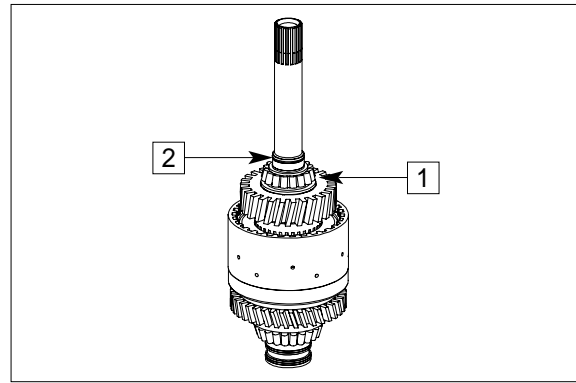

50DS7ETM147

※ Check closing and opening of the clutch by means of compressed air at the hole(see arrow).

Closing and opening of the clutch must be clearly audible.

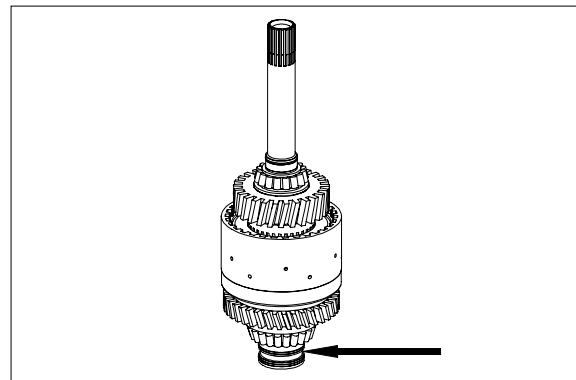

50DS7ETM148

(2) Clutch KV

The clutch(1) is supplied by the spare parts service only as a complete assy which consists of :

- 1A = Retaining ring
- 1B = Helical gear
- 1C = Disk carrier
- 1D = Shaft

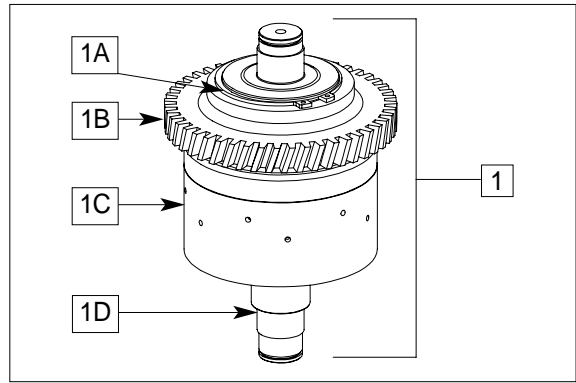

- ① Heat up bearing inner ring(approx. 120°C).

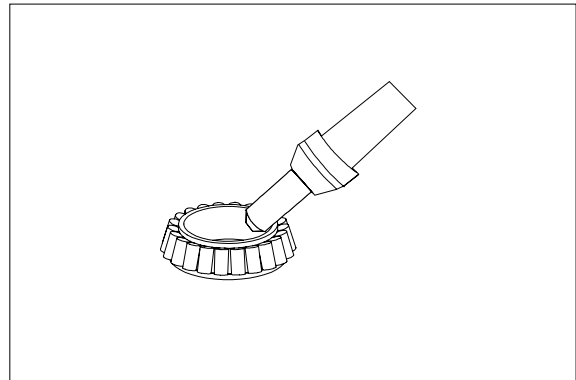

- ② Mount bearing inner ring(1) until contact is obtained.

Fit rectangular rings 30 × 2(2).

⚠ Wear protective gloves.

※ Adjust bearing inner ring after cooling-down.

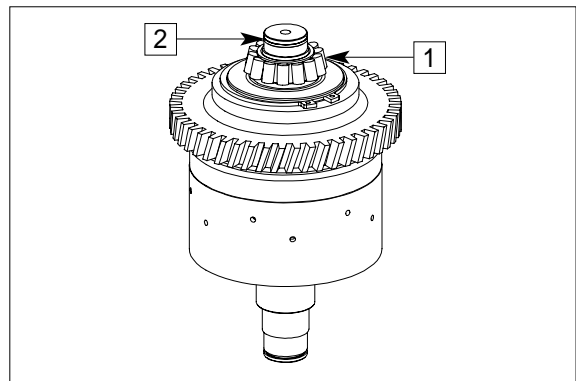

- ③ Insert both O-rings(1 and 2) into the piston grooves and oil them.

1 = 40 × 3

2 = 104.5 × 3

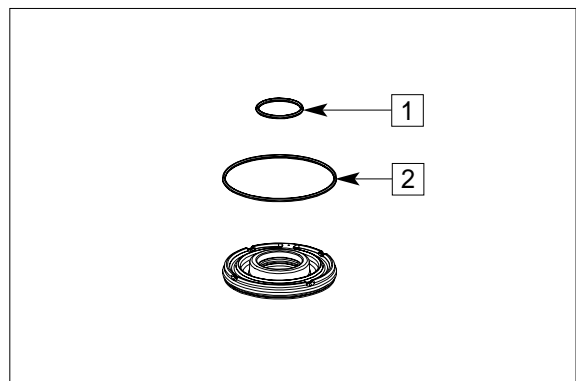

④ Insert piston(1) into the disk carrier.

※ Pay attention to the installation position, see figure.

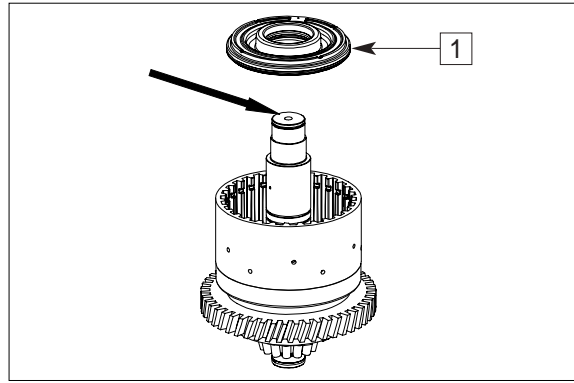

50DS7ETM76

⑤ Use a hand-operated press to place piston into the disk carrier by means of the assembly aid.

(S) Assembly aid 5870 345 114

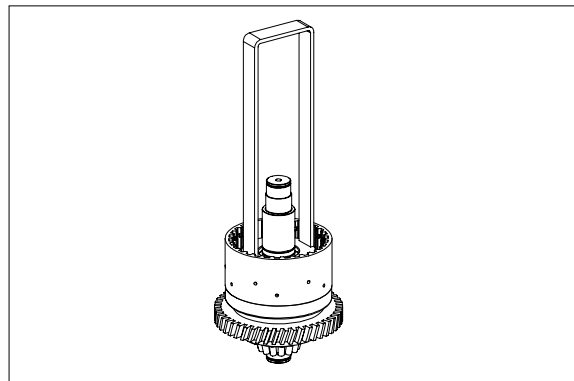

50DS7ETM154

⑥ Mount compression spring(1) and spring cup(2).

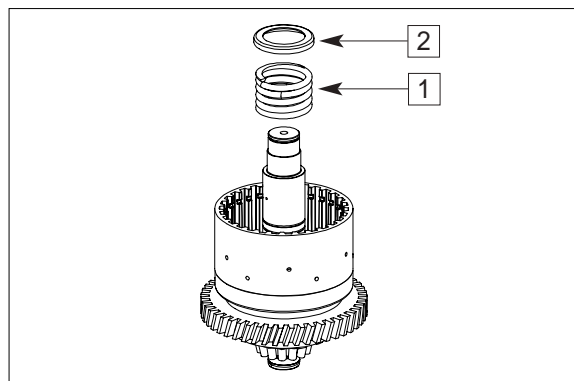

50DS7ETM75

⑦ By means of the assembly aid, preload compression spring under a hand-operated press until the retaining ring 40 × 1.75(1) can be snapped in.

(S) Assembly aid 5870 345 114

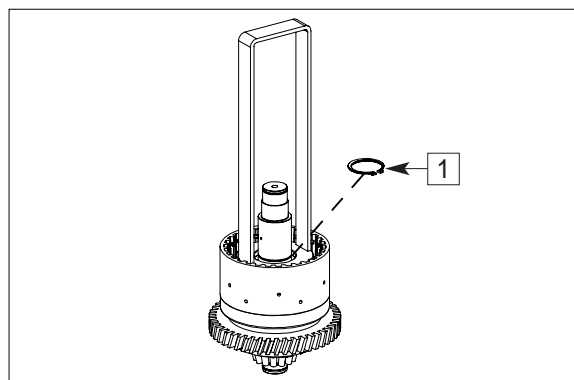

50DS7ETM74

- ⑧ Mount plate assy with cup springs(1), with the open side showing towards the piston(see arrow).

※ Installation position plate-see below figure.

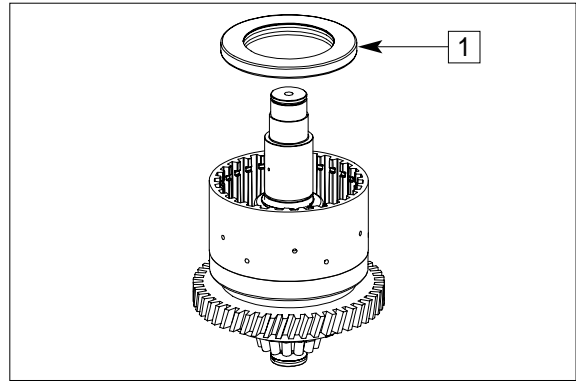

50DS7ETM157

- ⑨ Fit plate (1) according to sketch(see arrow).

- 1 = Plate with cup springs
- 2 = Compression spring with cup spring and retaining ring
- 3 = Piston with O-rings
- 4 = Clutch assy

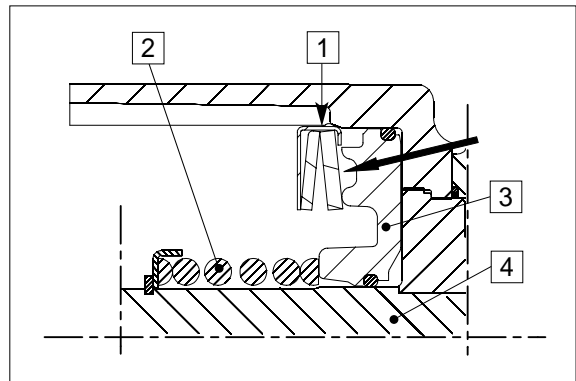

50DS7ETM158

- ⑩ Install outer and inner disks alternately into the disk carrier(3) as shown in figure.

Starting with an outer disk and ending with an inner disk.

- 1 = Outer disks(10 pcs)
- 2 = Inner disks(10 pcs)
- 3 = Clutch assy

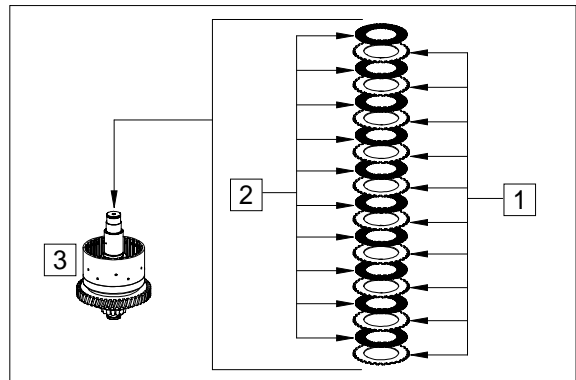

50DS7ETM159

- ⑪ Mount end plate(1) with the flat side showing towards the disk package and fix it by means of snap ring(2)(e.g. thickness=2.5mm/recommended value).

※ Pay attention to the installation position of the end plate.

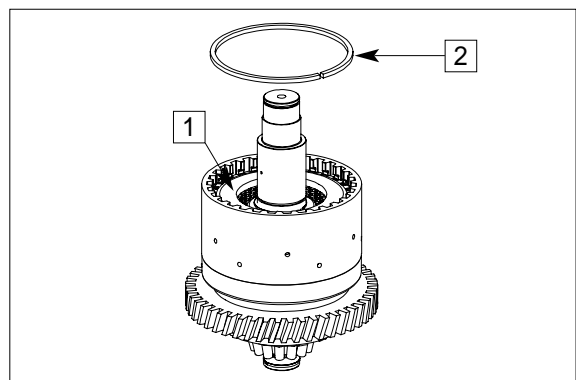

50DS7ETM160

- ⑫ Equally press on end plate with F (approx. 100N = 10kg) and set dial indicator to "zero".

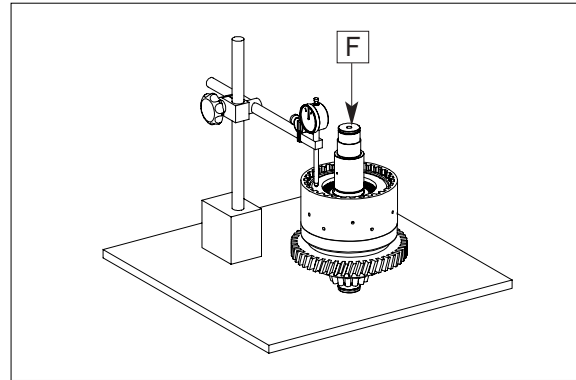

50DS7ETM161

- ⑬ Then press end plate against the snap ring (upwards) and read the disk clearance.

※ Disk clearance : 2.2 to 2.6mm

※ In case of deviations, the disk clearance must be corrected with an appropriate snap ring (optional thickness = 2.0~3.5mm/available in steps of 0.25mm).

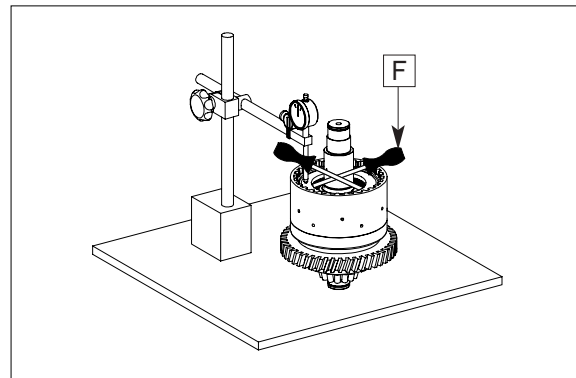

50DS7ETM162

- ⑭ Snap retaining ring 40 × 1.75(1) into the groove.

※ Contact for axial bearing—see below figure.

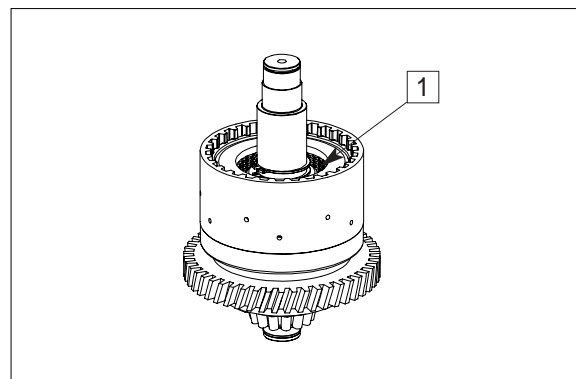

50DS7ETM163

- ⑮ Mount running disk 40 × 60 × 3.5(1), axial needle cage 40 × 60 × 3(2) and axial washer 40 × 60 × 1(3) and oil them.

※ Fit running disk(1), with the chamfer showing towards the retaining ring.

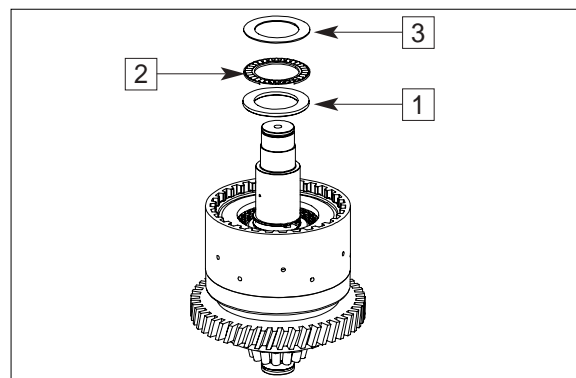

50DS7ETM164

- ⑩ Mount needle cage $40 \times 45 \times 17(1)$ and oil it.

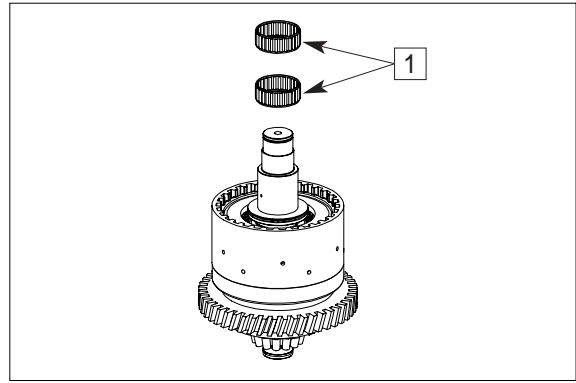

50DS7ETM69

- ⑪ Mount inner disk carrier until contact is obtained.

Install inner disks by short ccw/cw rotations of the inner disk carrier(1).

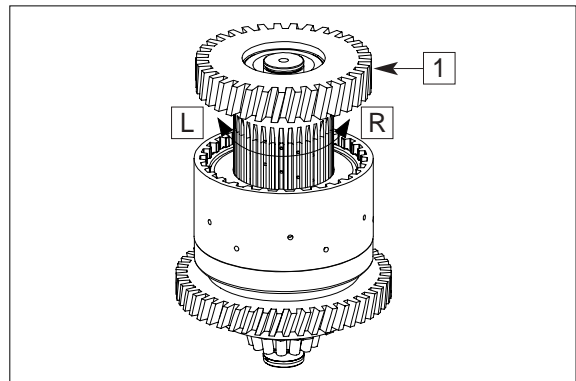

50DS7ETM166

- ⑫ Mount axial washer $40 \times 60 \times 1(1)$, axial needle cage $40 \times 60 \times 3(2)$ and running disk(3) $40 \times 60 \times 3.5$ and oil them.

※ Fit running disk(3), with the chamfer showing towards the tapered roller bearing.

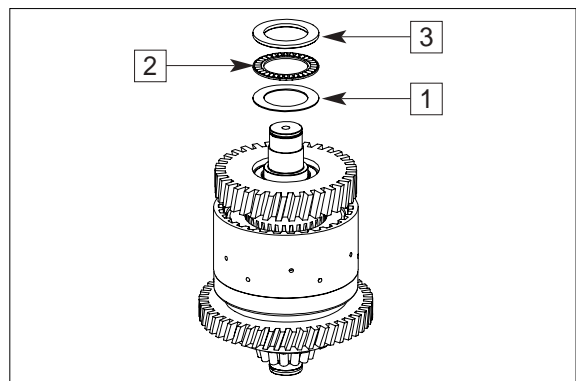

50DS7ETM167

- ⑬ Heat up bearing inner ring(approx. 120°C).

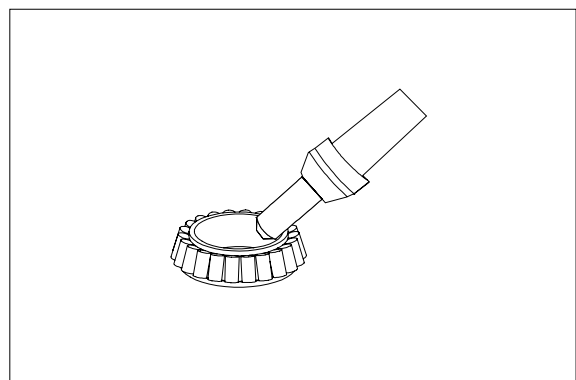

50DS7ETM128

② Mount bearing inner ring(1) until contact is obtained.

Fit rectangular ring $30 \times 2(2)$.

⚠ Wear protective gloves.

※ Adjust bearing inner ring after cooling-down.

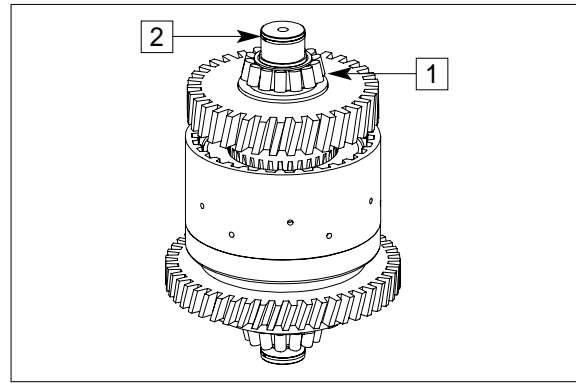

50DS7ETM169

※ Check closing and opening of the clutch by means of compressed air at the hole(see arrow).

Closing and opening of the clutch must be clearly audible.

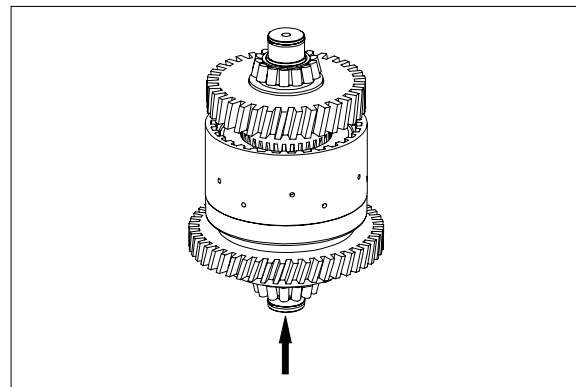

50DS7ETM170

(3) Clutch KD

※ The clutch(1) is supplied by the spare parts service only as a complete assy which consists of :

1A = Retaining ring

1B = Helical gear

1C = Disk carrier

1D = Shaft

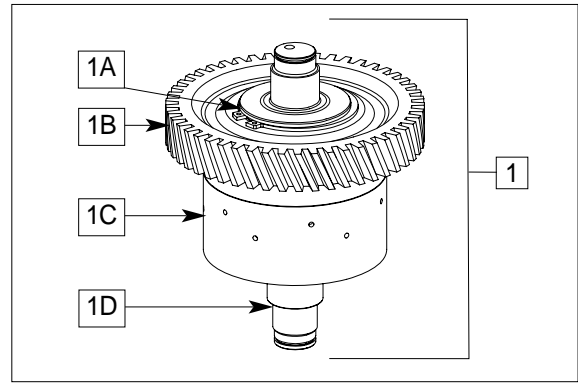

50DS7ETM95

① Heat up bearing inner ring(approx. 120°C).

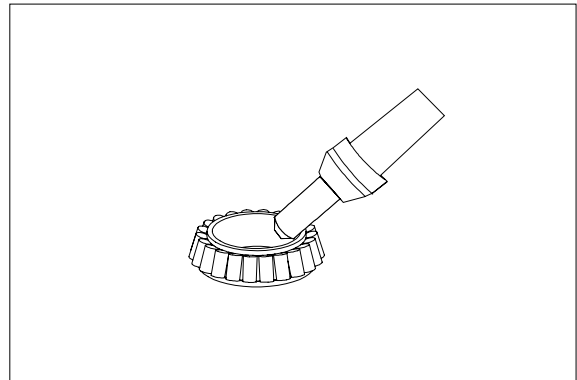

50DS7ETM128

② Mount bearing inner ring(1) until contact is obtained.

Fit rectangular rings 30 × 2(2).

▲ Wear protective gloves.

※ Adjust bearing inner ring after cooling-down.

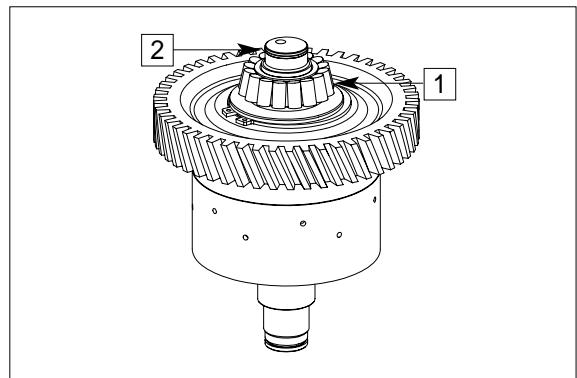

50DS7ETM171

③ Piston(1) with drain valve.

※ Check function of the drain valve (2). There must be no jamming of the ball(see arrow).

※ The piston(1) is supplied by the spare parts service only as a complete assy.

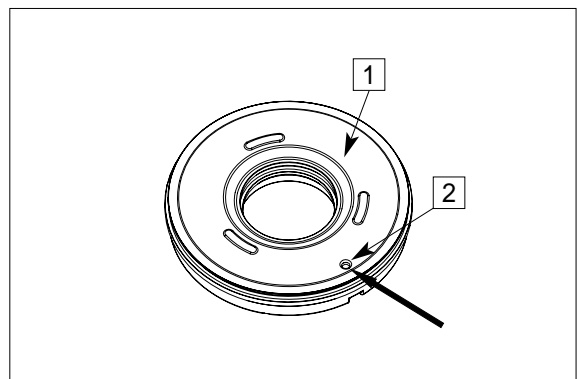

50DS7ETM172

- ④ Insert both O-rings(1 and 2) into the piston grooves and oil them.

1 = 40×3

2 = 104.5×3

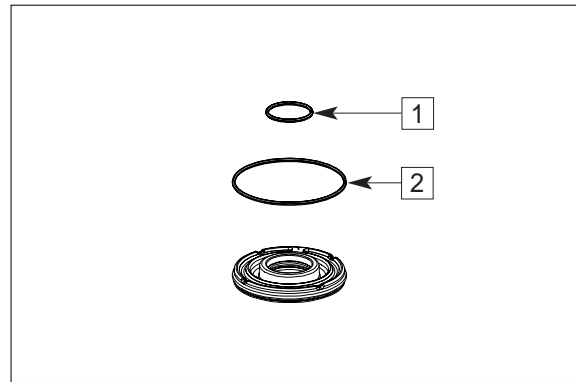

50DS7ETM62

- ⑤ Insert piston(1) into the disk carrier.

※ Pay attention to the installation position, see figure.

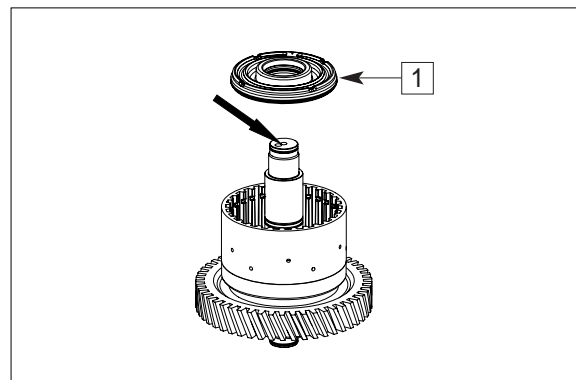

50DS7ETM91

- ⑥ Use a hand-operated press to place piston into the disk carrier by means of the assembly aid.

(S) Assembly aid

5870 345 114

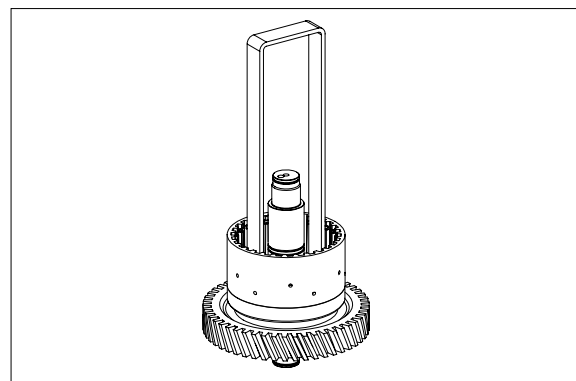

50DS7ETM173

- ⑦ Mount compression spring(1) and spring cup(2).

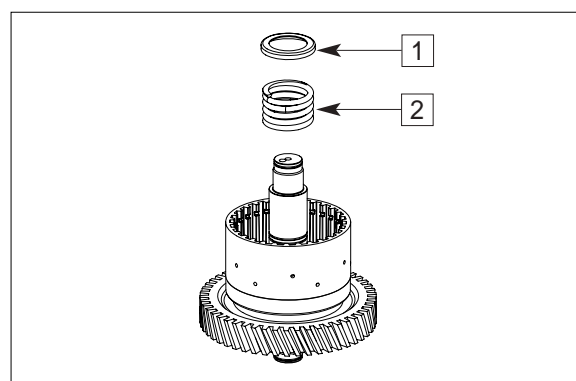

50DS7ETM90

- ⑧ By means of the assembly aid, preload compression spring under a hand-operated press until the retaining ring $40 \times 1.75(1)$ can be snapped in.

(S) Assembly aid 5870 345 114

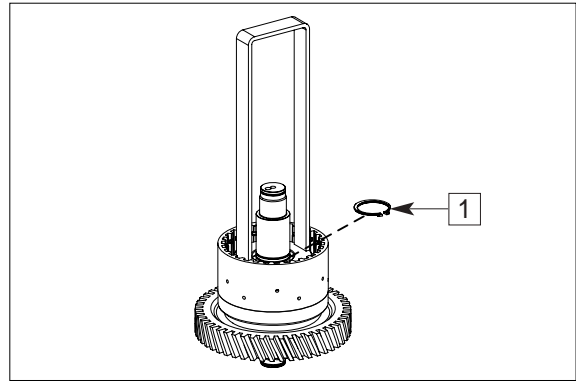

50DS7ETM89

- ⑨ Cup spring(1) into the disk carrier.

※ Pay attention to the installation position, see next page TM177.

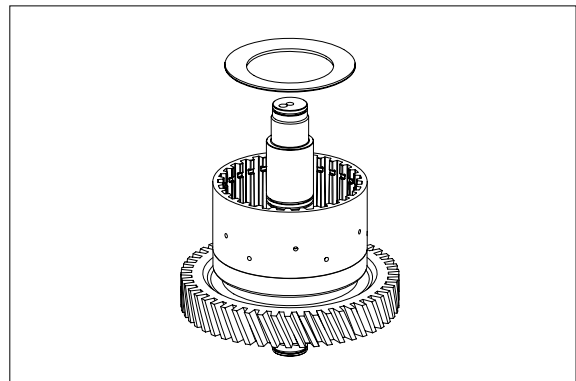

50DS7ETM174

- ⑩ Install outer and inner disks alternately into the disk carrier(3) as shown in figure.

Starting with an outer disk and ending with an inner disk.

1 = Outer disks(12 pcs)

2 = Inner disks(12 pcs)

3 = Clutch assy

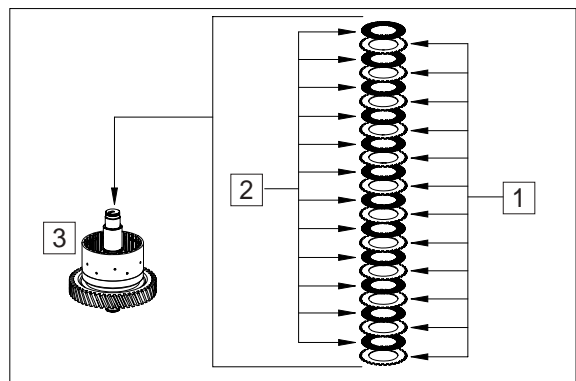

50DS7ETM175

- ⑪ Mount end plate(1) with the flat side showing towards the disk package and fix it by means of snap ring(2) (e.g. thickness = 2.5mm/recommended value).

※ Pay attention to the installation position of the end plate, see next page TM177.

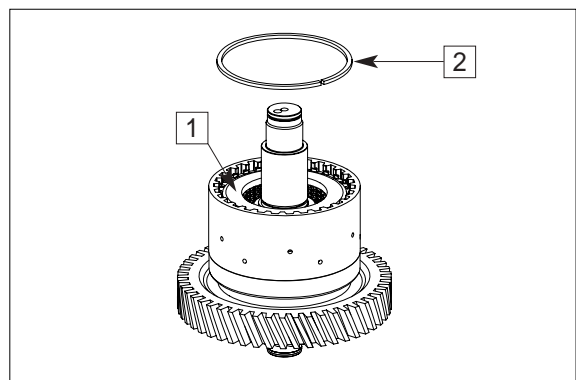

50DS7ETM176

⑫ Cap spring(1) according to sketch(see arrow).

- 1 = Cup spring
- 2 = Compression spring with spring cup and retaining ring
- 3 = Inner clutch- and outer clutch disc
- 4 = End shim
- 5 = Piston with O-rings
- 6 = Clutch assy.

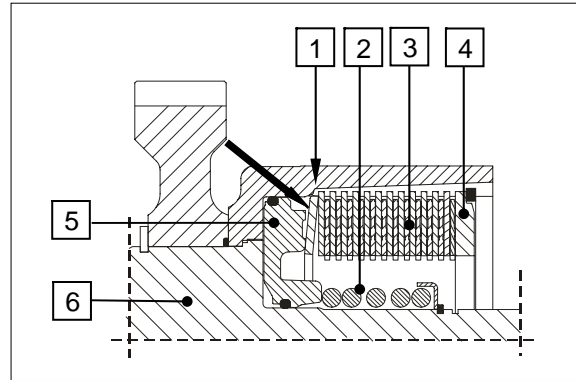

50DS7ETM177

⑬ Equally press on end plate with F (approx. 100N = 10kg) and set dial indicator to "zero".

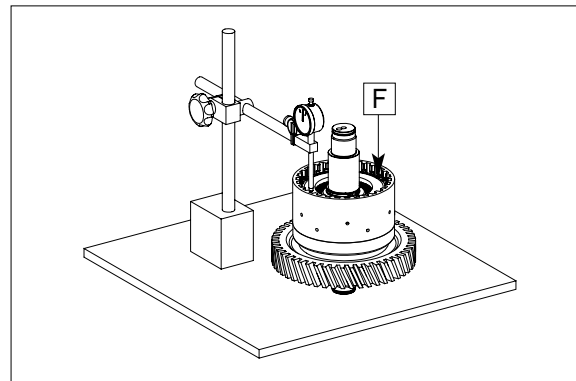

50DS7ETM178

⑭ Then press end plate against the snap ring(upwards) and read the disk clearance.

- ※ Disk clearance : 2.6 to 3.1mm.
- ※ In case of deviations, the disk clearance must be corrected with an appropriate snap ring(optional thickness = 2.0~3.5mm/available in steps of 0.25mm).

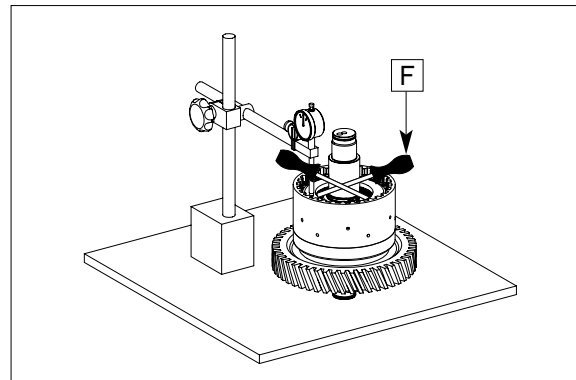

50DS7ETM179

⑮ Snap retaining ring 40 × 1.75(1) into the groove.

- ※ Contact for axial bearing - see next page TM181.

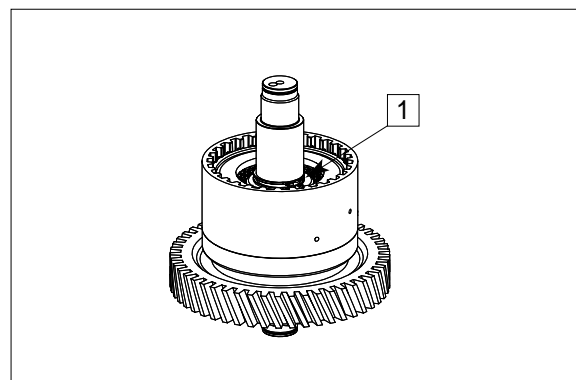

50DS7ETM180

- ⑯ Mount running disk $40 \times 60 \times 3.5$ (1), axial needle cage $40 \times 60 \times 3$ (2) and axial washer $40 \times 60 \times 1$ (3) and oil them.

※ Fit running disk(1), with the chamfer showing towards the retaining ring.

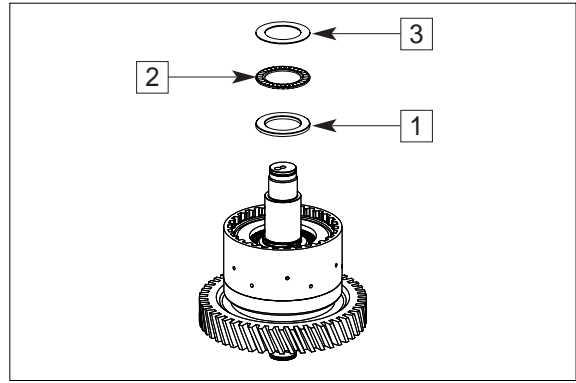

50DS7ETM181

- ⑰ Mount needle cage $40 \times 45 \times 17$ (1) and oil it.

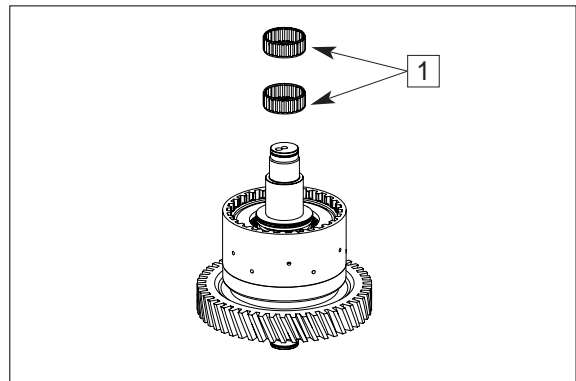

50DS7ETM84

- ⑱ Mount inner disk carrier until contact is obtained.

Install inner disks by short ccw/cw rotations of the inner disk carrier(1).

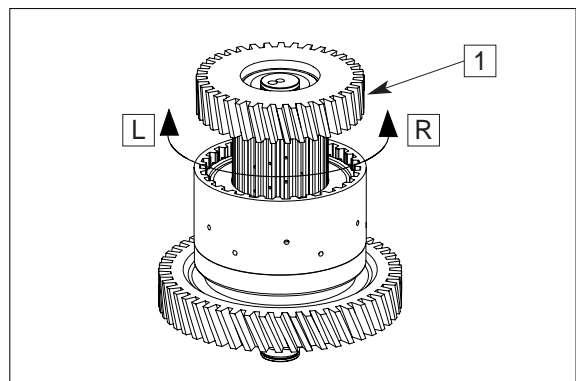

50DS7ETM182

- ⑲ Mount axial washer $40 \times 60 \times 1$ (1), axial needle cage $40 \times 60 \times 3$ (2) and running disk(3) $40 \times 60 \times 3.5$ and oil them.

※ Fit running disk(3), with the chamfer showing towards the tapered roller bearing.

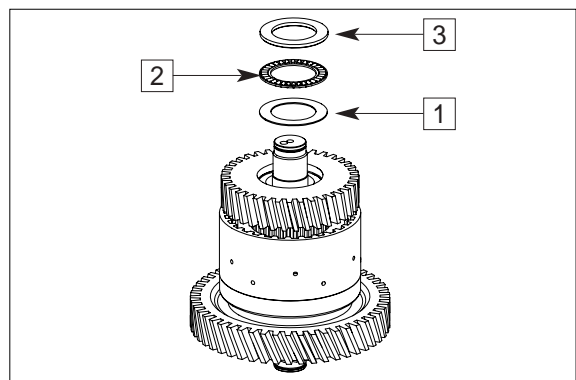

50DS7ETM183

- ① Heat up bearing inner ring (approx. 120°C).

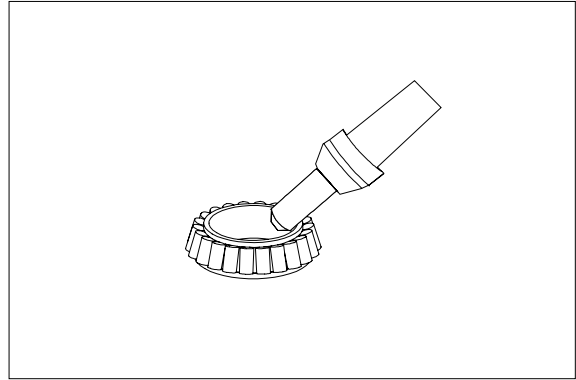

50DS7ETM128

- ② Mount bearing inner ring (1) until contact is obtained.

Fit rectangular ring 30 × 2 (2).

⚠ Wear protective gloves.

- ※ Adjust bearing inner ring after cooling-down.

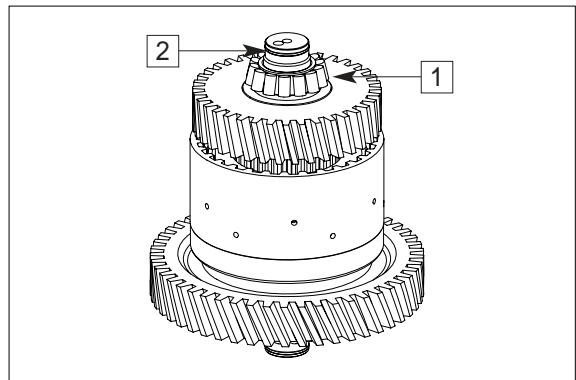

50DS7ETM184

- ※ Check closing and opening of the clutch by means of compressed air at the hole (see arrow). Closing and opening of the clutch must be clearly audible.

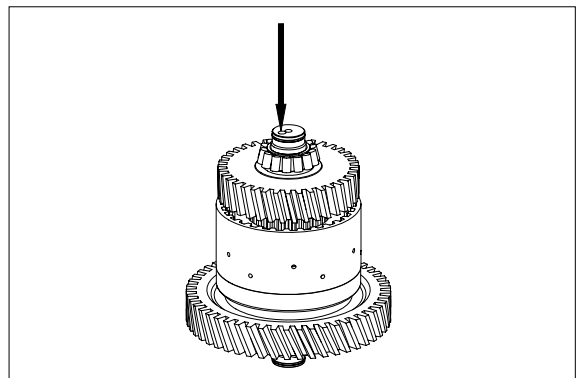

50DS7ETM185

(4) Clutch KE

※ The clutch(1) is supplied by the spare parts service only as a complete assy which consists of :

1A = Retaining ring

1B = Helical gear

1C = Disk carrier

1D = Shaft

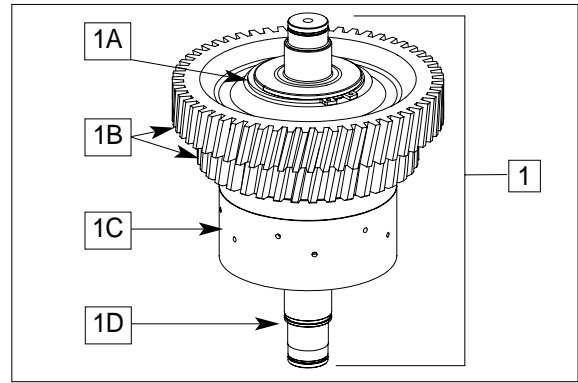

50DS7ETM111

① Heat up bearing inner ring(approx. 120°C).

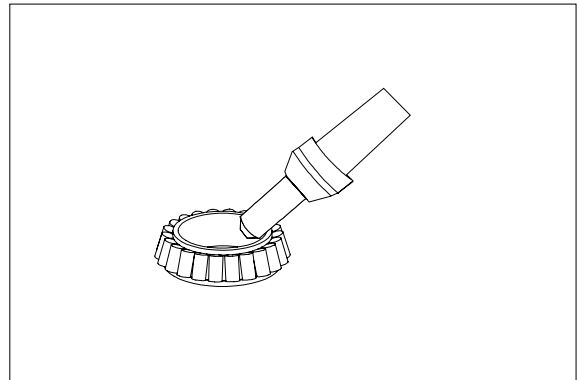

50DS7ETM128

② Mount bearing inner ring(1) until contact is obtained.

Fit rectangular ring 30 × 2(2).

▲ Wear protective gloves.

※ Adjust bearing inner ring after cooling-down.

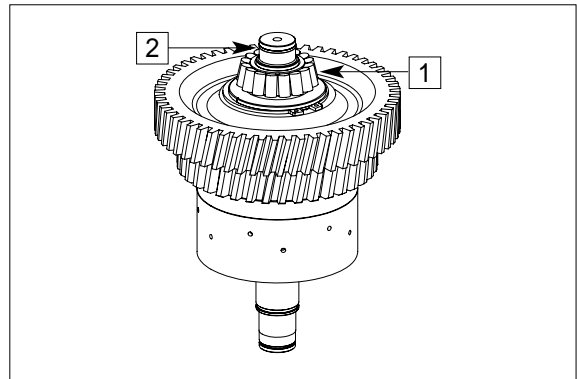

50DS7ETM186

③ Piston(1) with drain valve.

※ Check function of the drain valve(2). There must be no jamming of the ball(see arrow).

※ The piston(1) is supplied by the spare parts service only as a complete assy.

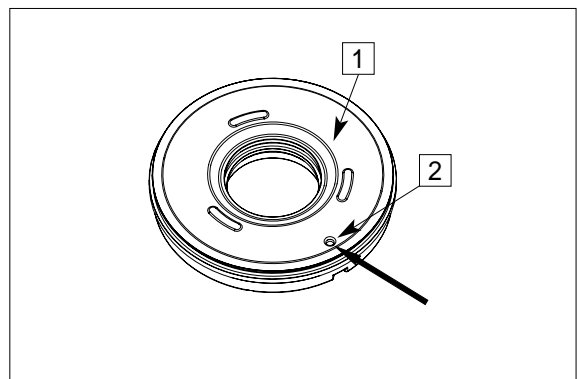

50DS7ETM187

- ④ Insert both O-rings(1 and 2) into the piston grooves and oil them.

1 = 40×3

2 = 104.5×3

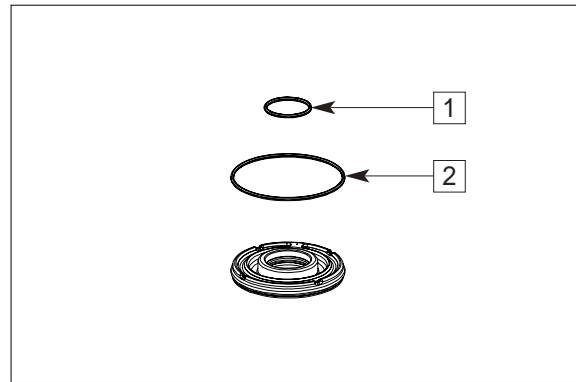

50DS7ETM62

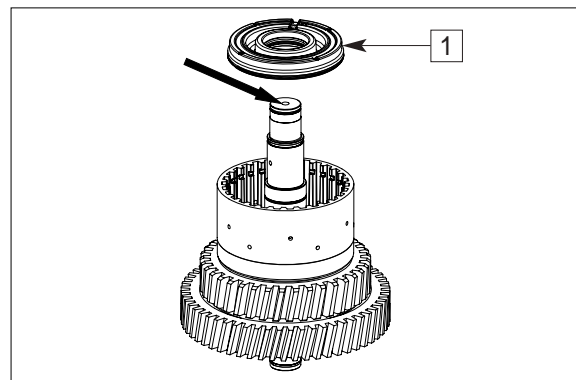

50DS7ETM107

- ⑤ Use a hand-operated press to place piston into the disk carrier by means of the assembly aid.

(S) Assembly aid

5870 345 114

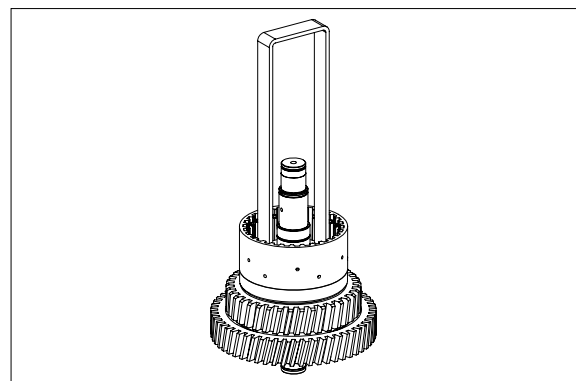

50DS7ETM188

- ⑥ Mount compression spring(1) and spring cup(2).

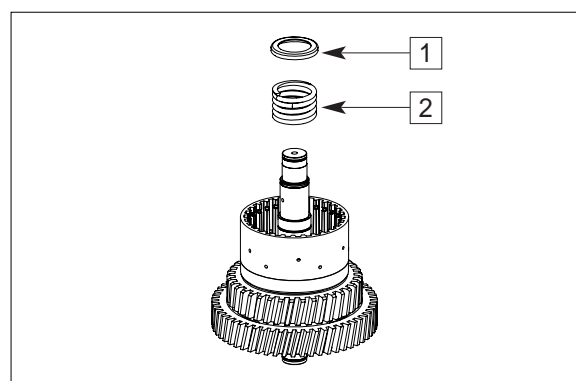

50DS7ETM106

- ⑦ By means of the assembly aid, preload compression spring under a hand-operated press until the retaining ring $40 \times 1.75(1)$ can be snapped in.

(S) Assembly aid 5870 345 114

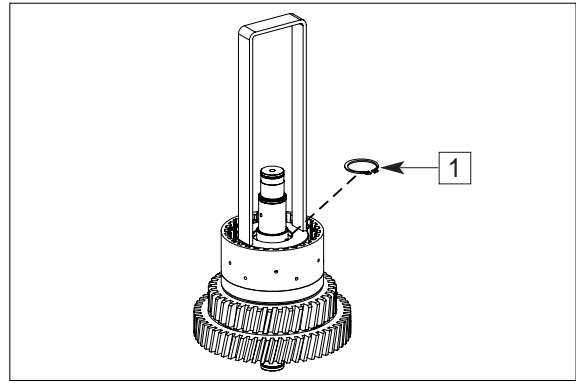

50DS7ETM105

- ⑧ Cup spring(1) into the disk carrier.

※ Pay attention to the installation position, see next page TM192.

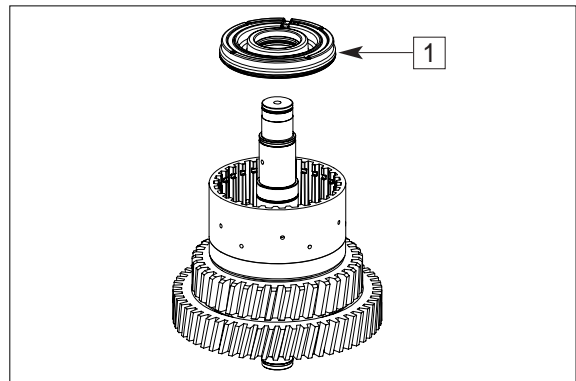

50DS7ETM189

- ⑨ Install outer and inner disks alternately into the disk carrier(3) as shown in figure.

Starting with an outer disk and ending with an inner disk.

1 = Outer disks(10 pcs)

2 = Inner disks(10 pcs)

3 = Clutch assy

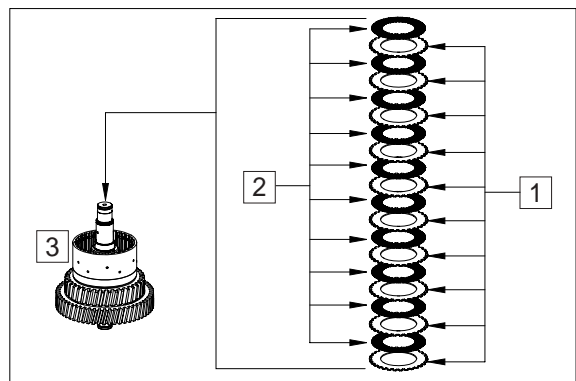

50DS7ETM190

- ⑩ Mount end plate(1) with the flat side showing towards the disk package and fix it by means of snap ring(2) (e.g. thickness=2.5mm/recommended value).

※ Pay attention to the installation position of the end plate, see next page TM192.

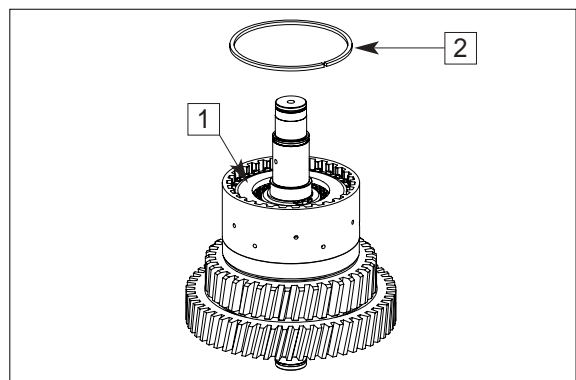

50DS7ETM191

⑪ Cap spring(1) according to sketch(see arrow).

1 = Cup spring

2 = Compression spring with spring cup and retaining ring

3 = Inner clutch-and outer clutch disc

4 = End shim

5 = Piston with O-rings

6 = Clutch assy

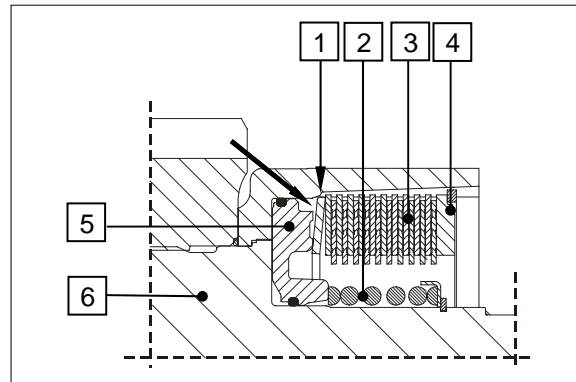

50DS7ETM192

⑫ Equally press on end plate with F (approx. 100 N = 10kg) and set dial indicator to "zero".

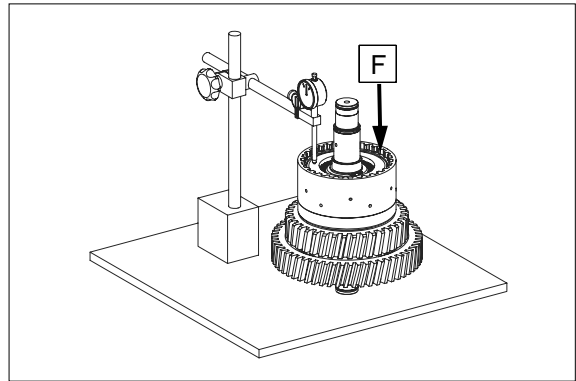

50DS7ETM193

⑬ Then press end plate against the snap ring (upwards) and read the disk clearance.

※ Disk clearance : 2.2 to 2.6mm.

※ In case of deviations, the disk clearance must be corrected with an appropriate snap ring (optional thickness=2.0~3.5mm/available in steps of 0.25mm).

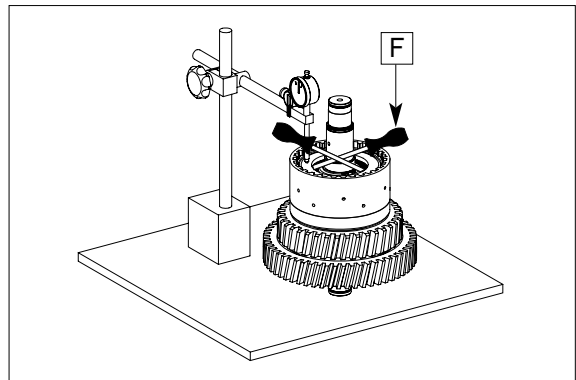

50DS7ETM194

⑭ Mount running disk 35 × 52 × 3.5(1).

※ Fit running disk(1), with the chamfer showing towards the retaining ring.

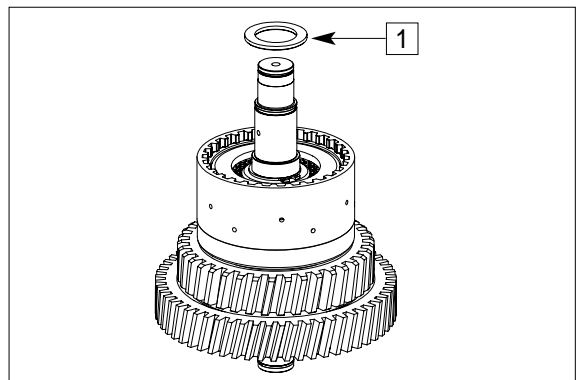

50DS7ETM195

- ⑮ Press in both bearing outer rings into the inner disk carrier(1) until contact is obtained.

Then mount the bearing inner rings.

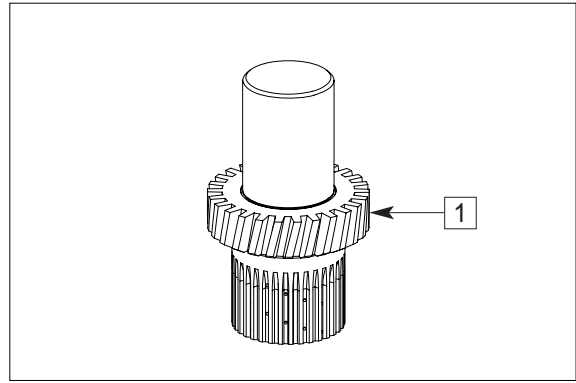

50DS7ETM196

- ※ Setting of axial play of the inner disk carrier bearing $\pm 0.05\text{mm}$ (see TM197 to TM202) :

- ⑯ Determine dimension "X2" of the inner disk carrier → see below figure.

Calculation example :

Dimension A	-----	97.00mm
Dimension B	-----	- 57.00mm
Dimension X2	-----	= 40.00mm

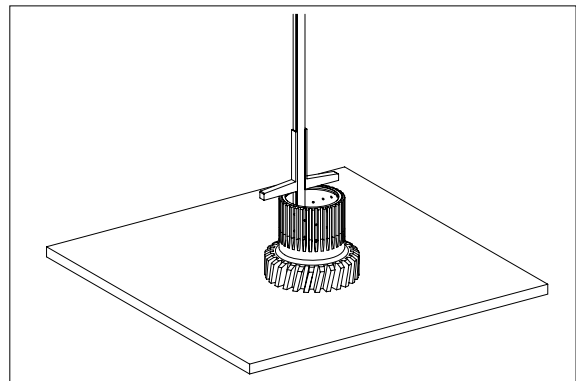

50DS7ETM197

- ⑰ Legend :

- 1 = Inner disk carrier
 2 = Tapered roller bearing $59 \times 35 \times 16$
 3 = Tapered roller bearing $62 \times 35 \times 18$

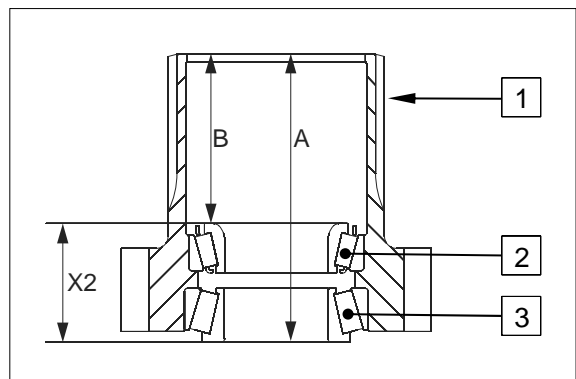

50DS7ETM198

- ⑱ Mount the retaining ring e.g. $35 \times 2.0(1)$ and bring it into contact position by means of a two-armed puller.

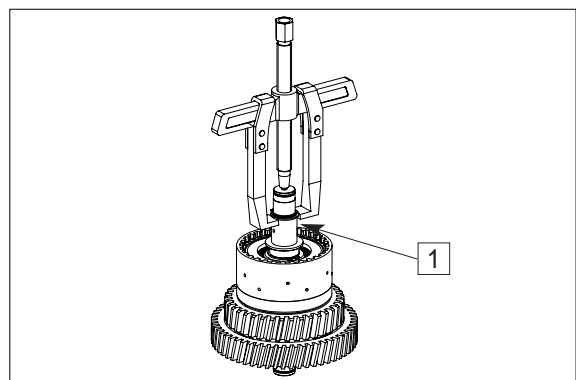

50DS7ETM199

- ⑱ Determine dimension "X1" from retaining ring(1) to running disk(2).
→ see below figure.

Dimension X1 = 42.1mm

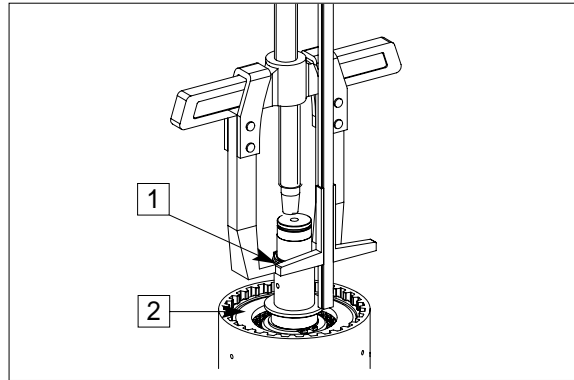

50DS7ETM200

- ㉑ Legend :

- 1 = Retaining ring 35 × 2.0
- 2 = Running disk 35 × 52 × 3.5
- 3 = Compression spring with cup spring and retaining ring
- 4 = Disk package with end plate and snap ring
- 5 = Piston with O-rings
- 6 = Clutch assy
- 7 = Tapered roller bearing

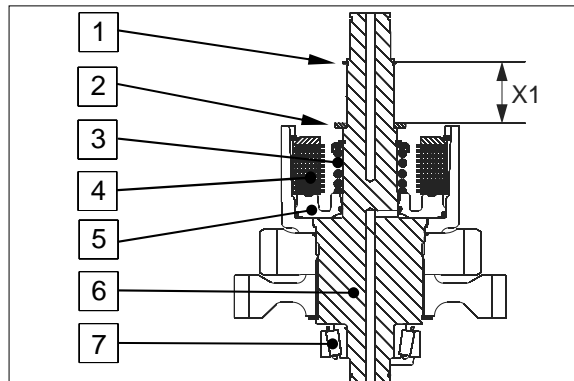

50DS7ETM201

- ㉒ Axial play of inner disk carrier bearing ±0.05

Calculation example :

Dimension X1 -----	42.10mm
Dimension X2 -----	- 40.00mm
Dimension S(retaining ring) ---	= 2.10mm

- ※ Determined retaining ring S = 2.10mm
- ※ Axial play must be set with the retaining ring (optional thickness = 1.8~2.7mm/available in steps of 0.10mm).

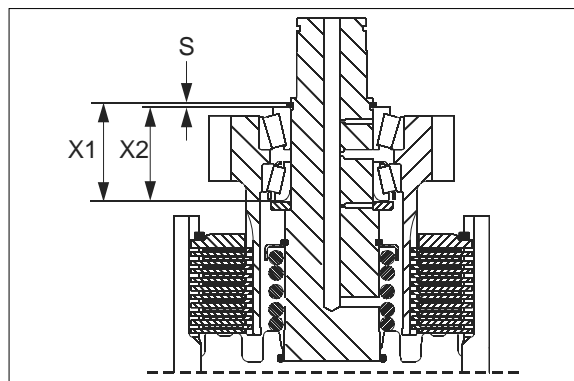

50DS7ETM202

- ㉓ Heat up bearing inner ring (approx. 120° C).

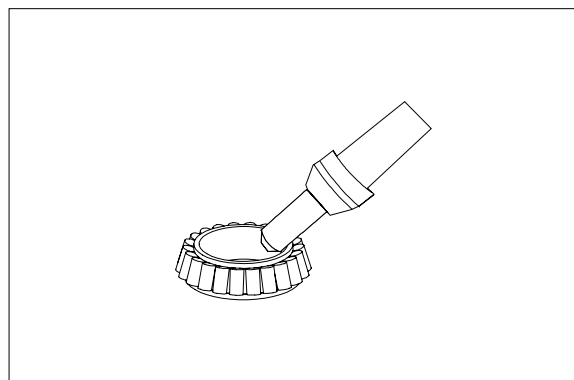

50DS7ETM128

㉓ Mount bearing inner ring(1) until contact is obtained.

※ Different bearing sizes → see page 3-124 TM198.

▲ Wear protective gloves.

※ Adjust bearing inner ring after cooling-down.

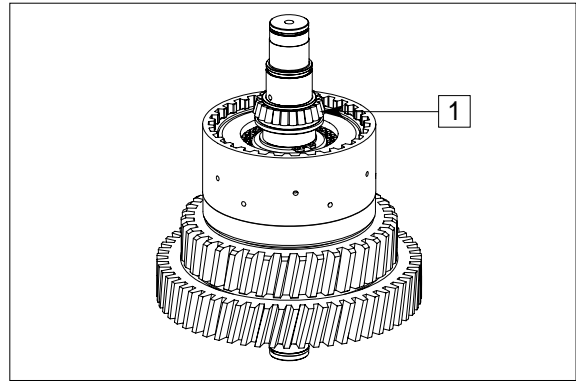

50DS7ETM203

㉔ Mount inner disk carrier until contact is obtained.

Install inner disks by short ccw/cw rotations of the inner disk carrier(1).

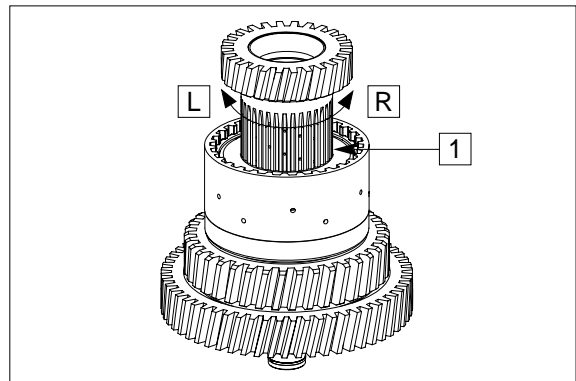

50DS7ETM204

㉕ Heat up bearing inner ring(approx. 120° C).

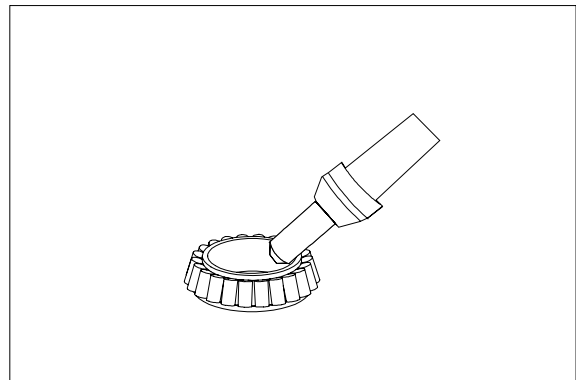

50DS7ETM128

㉖ Mount bearing inner ring(1) until contact is obtained.

▲ Wear protective gloves.

※ Adjust bearing inner ring after cooling-down.

Snap in retaining ring 35 × 2.1(2).

※ Pay attention to an exact contact of the retaining ring in the groove.

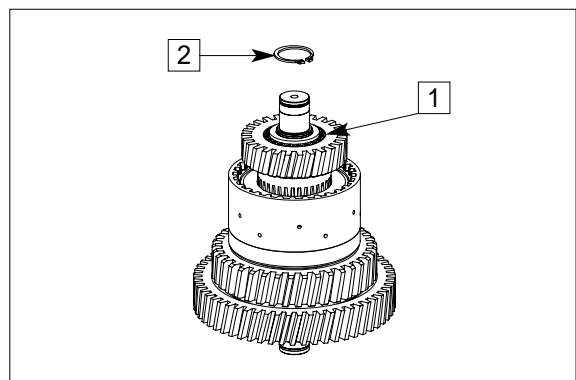

50DS7ETM205

- ⑳ Heat up bearing inner ring (approx. 120° C).

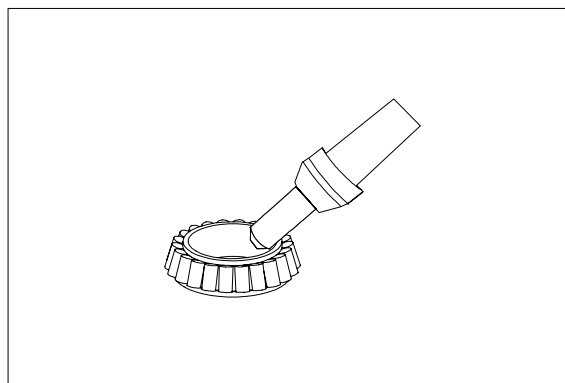

50DS7ETM128

- ㉑ Mount bearing inner ring (1) until contact is obtained.
Fit rectangular ring 30 × 2 (2).

⚠ Wear protective gloves.

※ Adjust bearing inner ring after cooling-down.

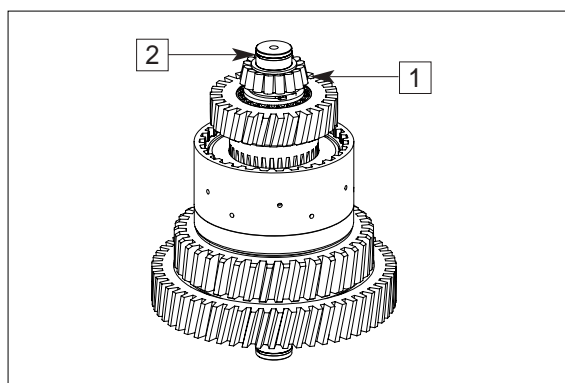

50DS7ETM206

- ※ Check closing and opening of the clutch by means of compressed air at the hole (see arrow).
Closing and opening of the clutch must be clearly audible.

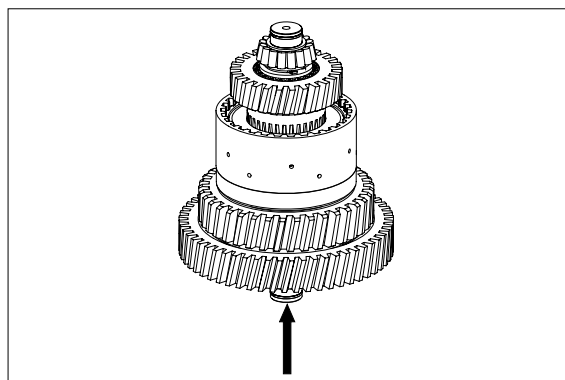

50DS7ETM207

(5) Clutch KC

※ The clutch(1) cannot be disassembled.
It is supplied by the spare parts service
only as a complete assy which consists of :

1A = Retaining ring

1B = Helical gear

1C = Disk carrier

1D = Shaft

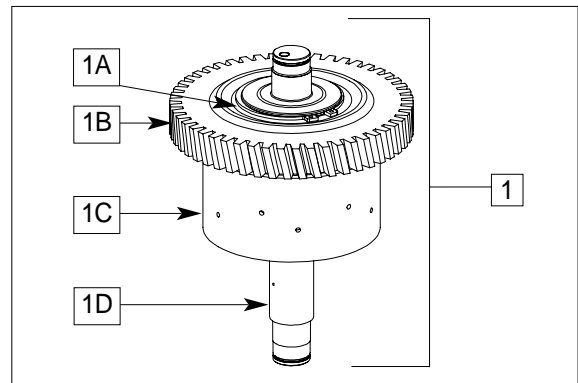

50DS7ETM124

① Heat up bearing inner ring(approx.
120°C).

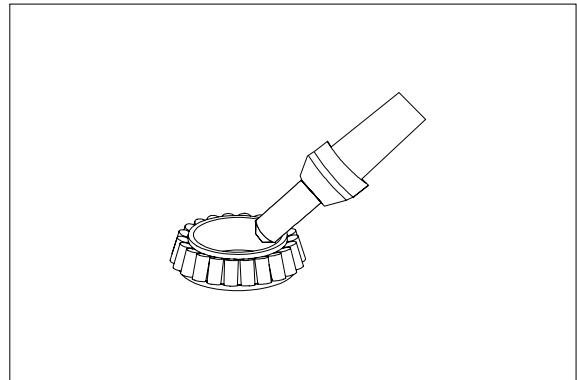

50DS7ETM128

② Mount bearing inner ring(1) until contact
is obtained.

Fit rectangular rings 30×2(2).

▲ Wear protective gloves.

※ Adjust bearing inner ring after cooling-down.

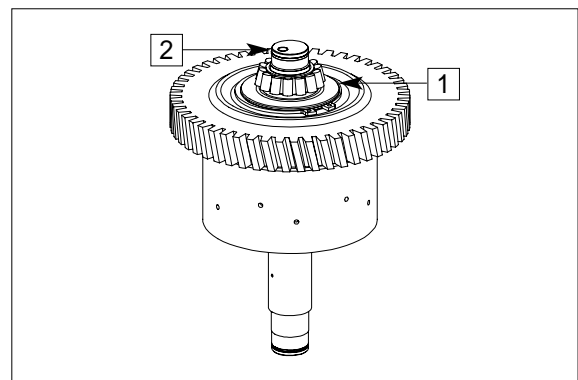

50DS7ETM208

③ Insert both O-rings(1 and 2) into the
piston(3) grooves and oil them.

1 = 115×3

2 = 52×3

Insert piston(3) into the disk carrier.

※ Pay attention to the installation posi-
tion, see next page TM211.

※ Check function of the drain valve (see
arrow) - There must be no jamming of
the ball.

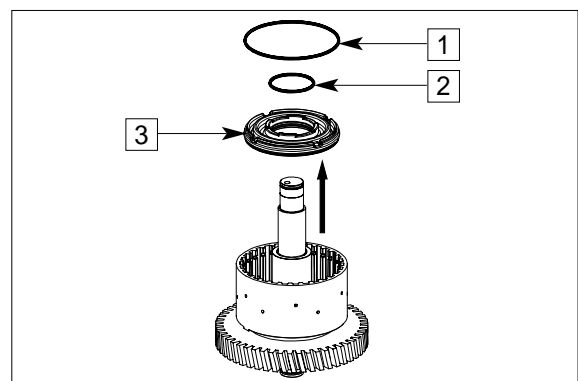

50DS7ETM209

- ④ Use a hand-operated press to place piston into the disk carrier by means of the assembly aid.

(S) Assembly aid 5870 345 114

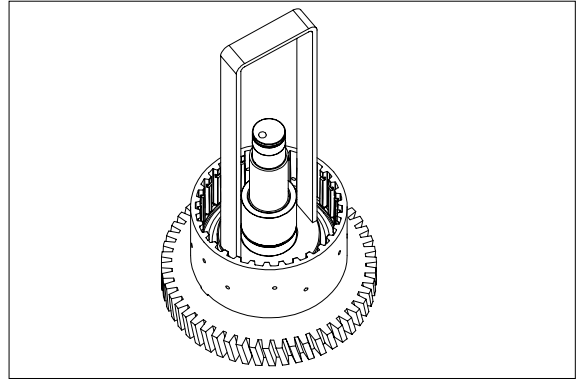

50DS7ETM210

- ⑤ Mount cup spring package(1) and disk (2).

※ Installation position of the cup springs, see below figure.

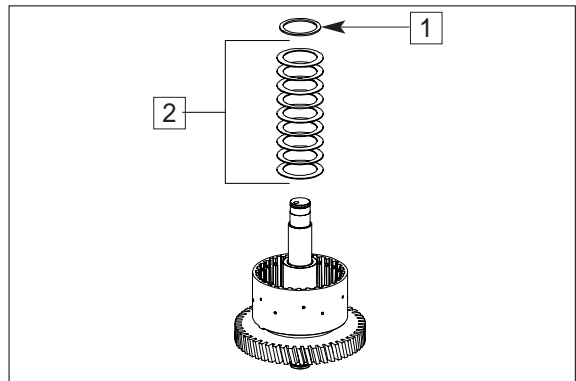

50DS7ETM120

- ⑥ Install cup springs according to the sketch.

1 = Clutch
 2 = Cup springs(9 pcs)
 3 = Disk
 4 = Retaining ring(50×2)
 5 = Drain valve(piston)
 6 = Piston with O-Rings

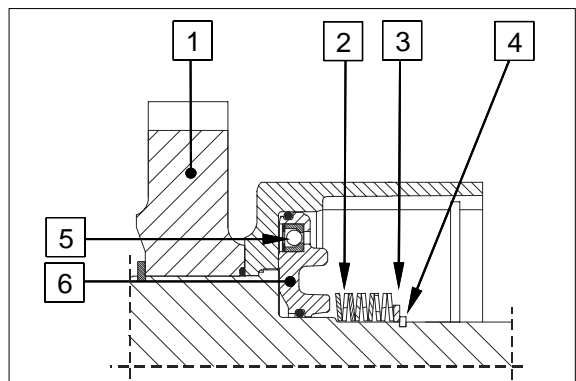

50DS7ETM211

- ⑦ By means of the assembly aid, preload cup springs under a handoperated press until the retaining ring 50×2(1) can be snapped in.

(S) Assembly aid 5870 506 128

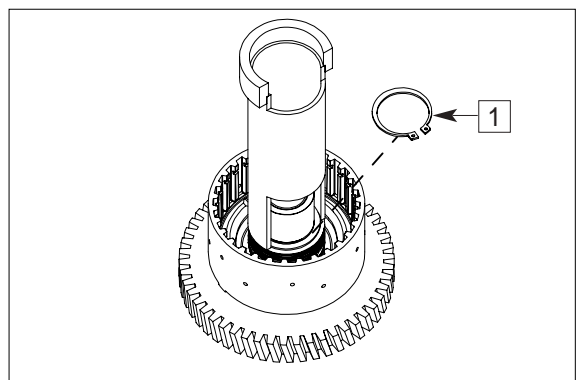

50DS7ETM119

- ⑧ Install outer and inner disks alternately into the disk carrier(3) as shown in figure.

Starting with an outer disk and ending with an inner disk.

- 1 = Outer disks(10 pcs)
- 2 = Inner disks(10 pcs)
- 3 = Clutch assy

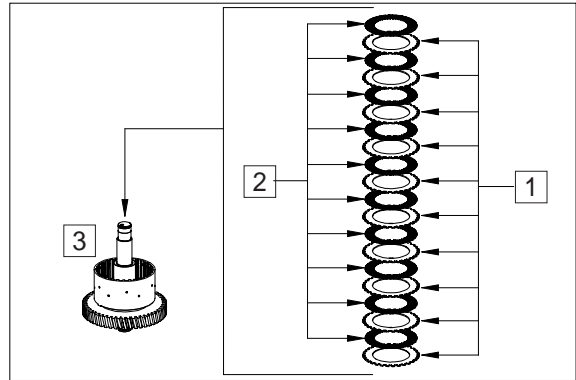

50DS7ETM212

- ⑨ Mount end plate(1) with the flat side showing towards the disk package and fix it by means of snap ring(2)(e.g. thickness=2.5mm/recommended value).

- ※ Pay attention to the installation position of the end plate.

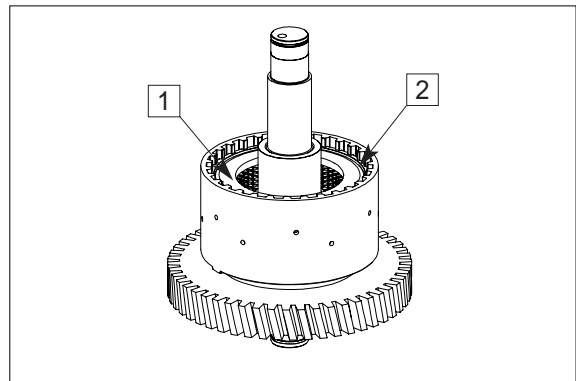

50DS7ETM213

- ⑩ Equally press on end plate with F (approx. 18 N to 20 N = 1.8 to 2.0kg) and set dial indicator to "zero".

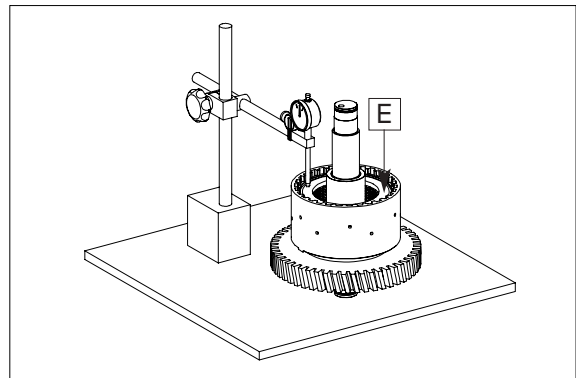

50DS7ETM214

- ⑪ Then press end plate against the snap ring(upwards) and read the disk clearance.

- ※ Disk clearance : 2.0 to 3.0mm.
- ※ In case of deviations, the disk clearance must be corrected with an appropriate snap ring(optional thickness s=2.0~4.0mm/available in steps 0.25mm).

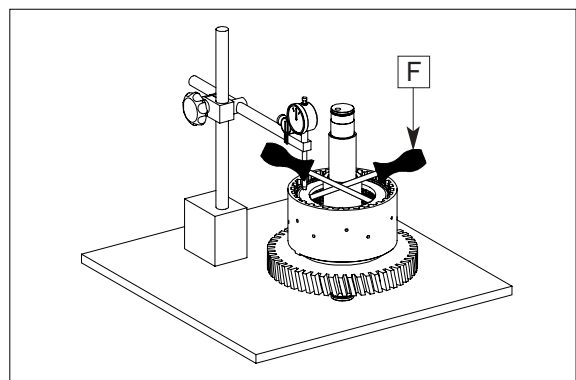

50DS7ETM215

- ⑫ Mount axial needle cage $35 \times 52 \times 2$ (1) and axial disk $35 \times 52 \times 1$ (1) and oil them.

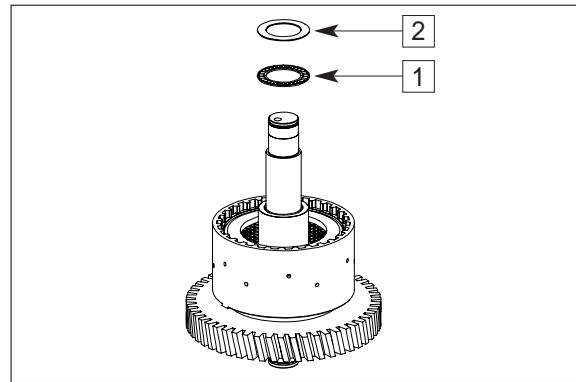

50DS7ETM116

- ⑬ Mount needle cage $35 \times 42 \times 18$ (1) and bush (2) and oil it.

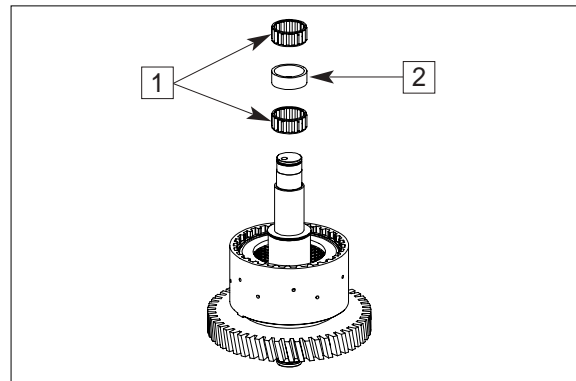

50DS7ETM115

- ⑭ Mount inner disk carrier until contact is obtained.

Install inner disks by short ccw/cw rotations of the inner disk carrier (1).

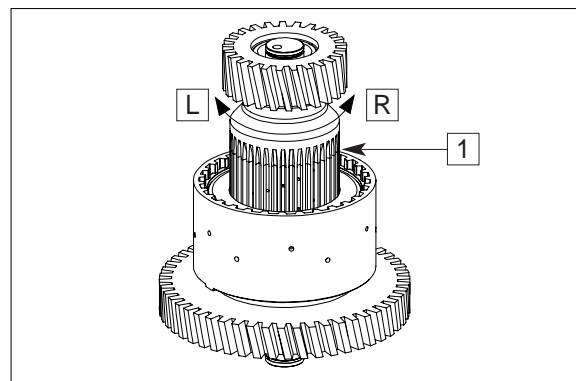

50DS7ETM216

- ⑮ Mount axial washer $35 \times 60 \times 1$ (1), axial needle cage $40 \times 60 \times 3$ (2) and running disk (3) $40 \times 60 \times 3.5$ and oil them.

※ Fit running disk (3), with the chamfer showing towards the tapered roller bearing.

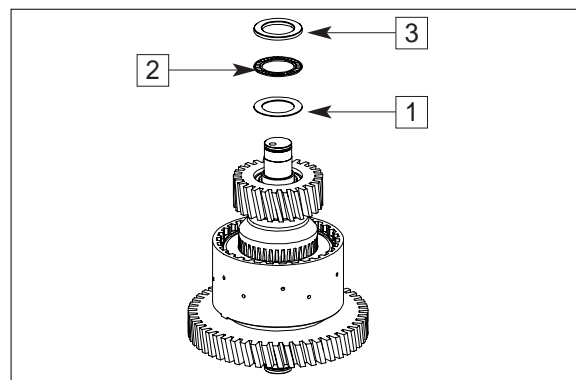

50DS7ETM217

- ⑩ Heat up bearing inner ring (approx. 120°C).

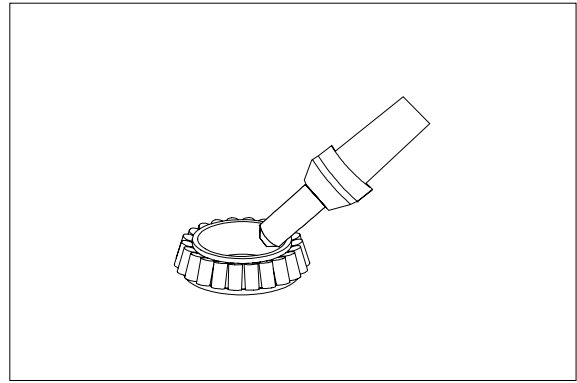

50DS7ETM128

- ⑪ Mount bearing inner ring (1) until contact is obtained.

Fit rectangular ring 30 × 2 (2).

⚠ Wear protective gloves.

※ Adjust bearing inner ring after cooling-down.

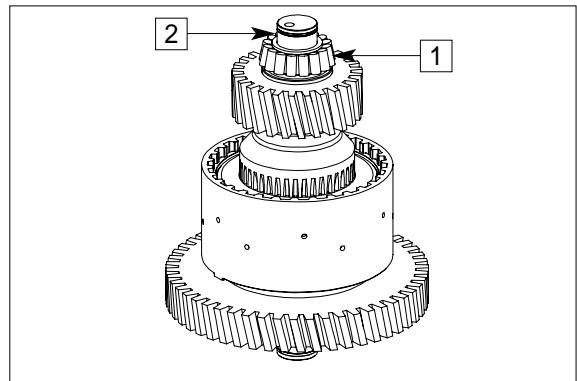

50DS7ETM218

※ Check closing and opening of the clutch by means of compressed air at the hole (see arrow). Closing and opening of the clutch must be clearly audible.

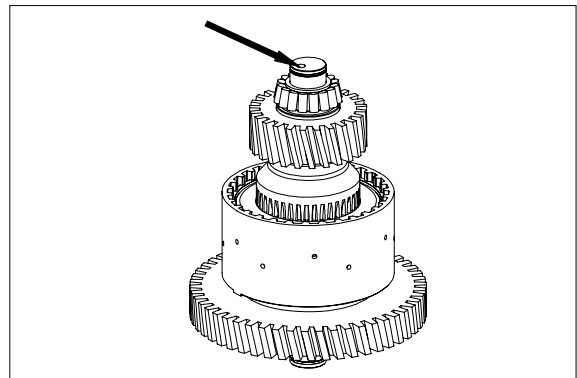

50DS7ETM219

(6) Output

- ① Heat up bearing inner ring (approx. 120°C).

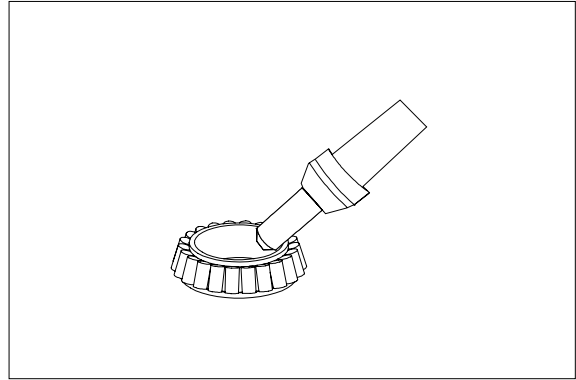

50DS7ETM128

- ② Mount bearing inner ring (1) until contact is obtained.

⚠ Wear protective gloves.

※ Adjust bearing inner ring after cooling-down.

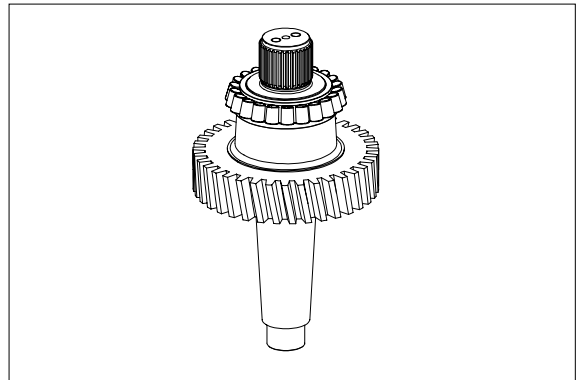

50DS7ETM220

- ③ Heat up bearing inner ring (approx. 120°C).

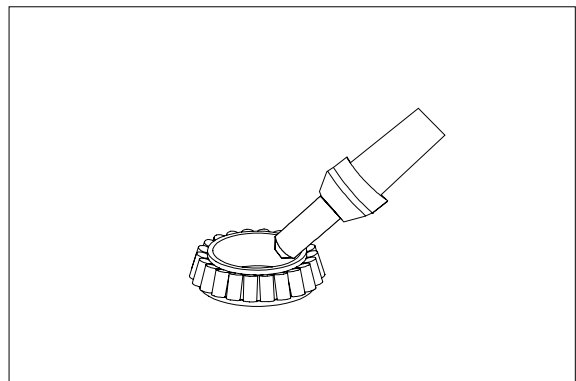

50DS7ETM128

- ④ Mount bearing inner ring (1) until contact is obtained.

⚠ Wear protective gloves.

※ Adjust bearing inner ring after cooling-down.

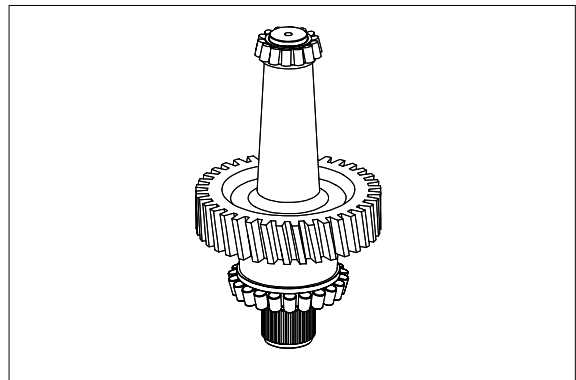

50DS7ETM221

2) REASSEMBLY OF OIL PRESSURE PUMP AND REINSTALLATION OF CLUTCHES

(1) Reassembly of oil pressure pump

※ In case of wear marks in the pump housing, stator hollow shaft, inner rotor, outer rotor and on the sliding bearing, the pump assy must be replaced.

1 = Stator hollow shaft

2 = Inner rotor

3 = Outer rotor

4 = Pump housing with sliding bearing

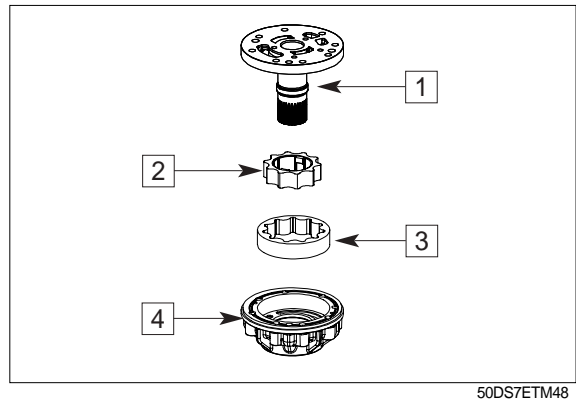

① With the sealing lip showing downwards, carefully insert the shaft seal 55×75×8 (1) into the pump housing(2) until contact is obtained.

※ Apply sealing agent(Loctite no. 574) to the outer diameter.

(S) Driver tool

5870 048 219

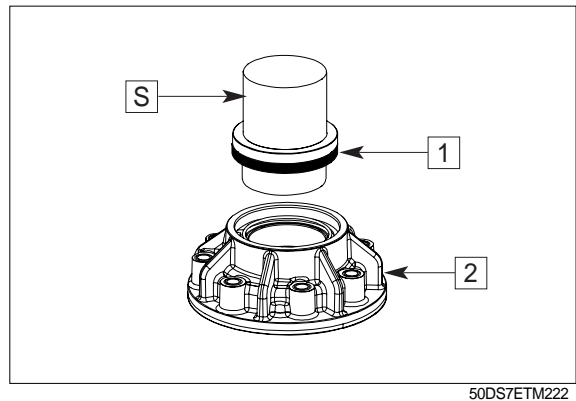

② Mount outer rotor(1) and inner rotor(2).

※ The driver pins of the inner rotor (see arrows) are to be fitted in upward direction.

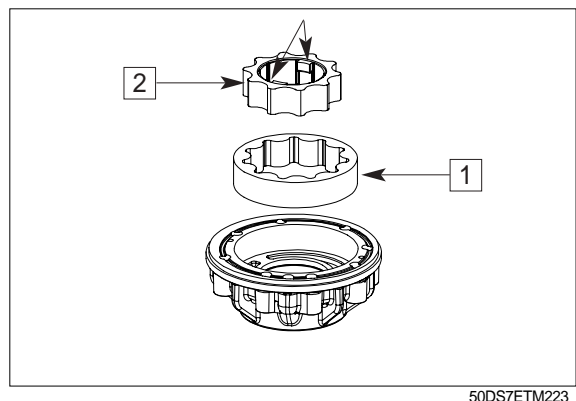

③ Fit stator hollow shaft(1).

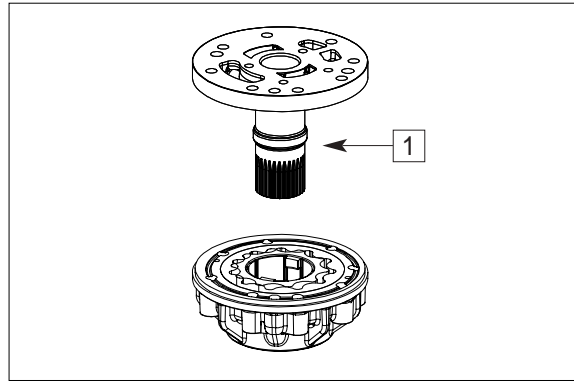

50DS7ETM224

④ Fix stator hollow shaft radially with two cylindrical screws(1).

※ Do not tighten the cylindrical screws - just turn them in until contact is obtained and then turn them back by approx. $\frac{1}{2}$ rotation.

Place O-ring(2) 135×3 into the annular groove and grease it.

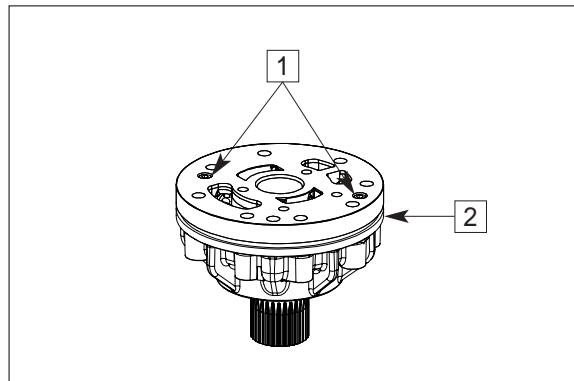

50DS7ETM225

⑤ Insert filter(1).

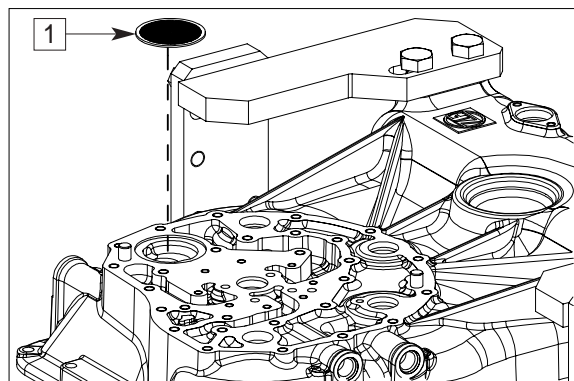

50DS7ETM226

⑥ Wet mounting face bell housing with Loctite(type no. 574).

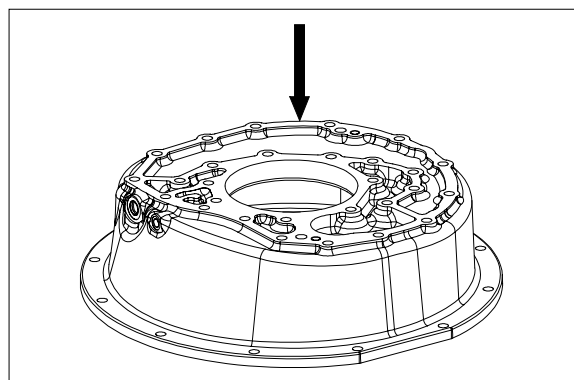

50DS7ETM227

- ⑦ Fit two adjusting screws(S) and position converter bellhousing(1) equally until contact is obtained.

※ Pay attention to the hole pattern.

(S) Adjusting screws(M10) 5870 204 007

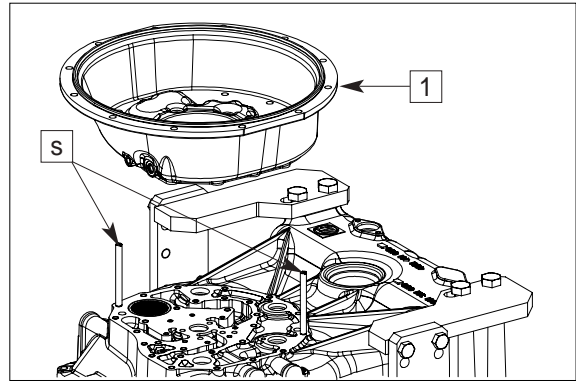

50DS7ETM228

- ⑧ Force the cylindrical pins 12×24(1) into the holes(blind holes) until contact is obtained.

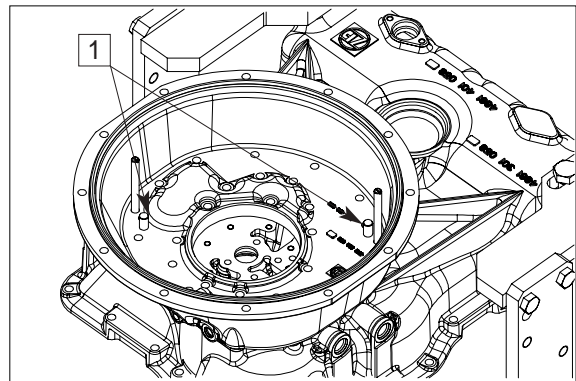

50DS7ETM229

- ⑨ Fix converter bell housing(1) with cylindrical screws M10×30(2).

Tightening torque(M10/8.8×30)
 $M_A = 46\text{Nm}$

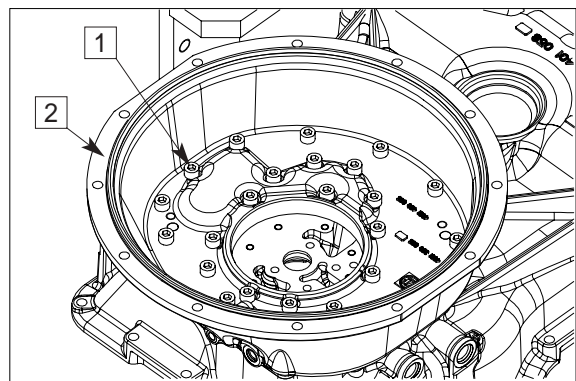

50DS7ETM230

- ⑩ Fit two adjusting screws(S) and mount preassembled pump(1).

※ Pay attention to the hole pattern.

(S) Adjusting screws(M8) 5870 204 011

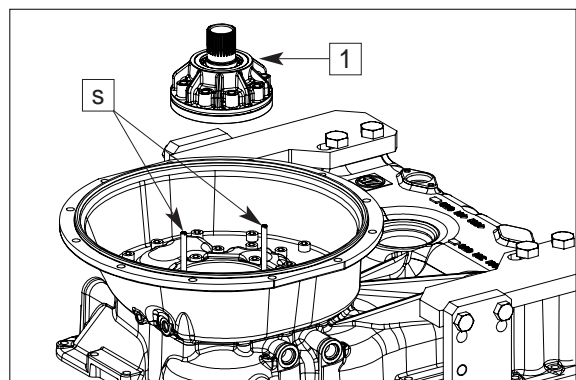

50DS7ETM231

- ⑪ Position transmission pump with 3 cylindrical screws(1) M8 × 60(3 × 120° offset position) equally until contact is obtained.

※ Do not damage(shear off) the O-ring.

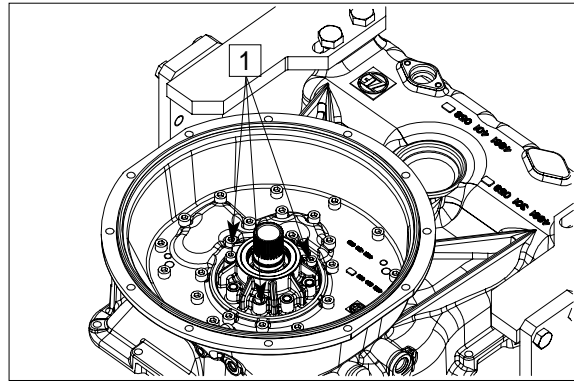

50DS7ETM232

- ⑫ Fix transmission pump with cylindrical screws M8 × 60(1).

Tightening torque (M8/8.8 × 60) $M_A = 23\text{Nm}$

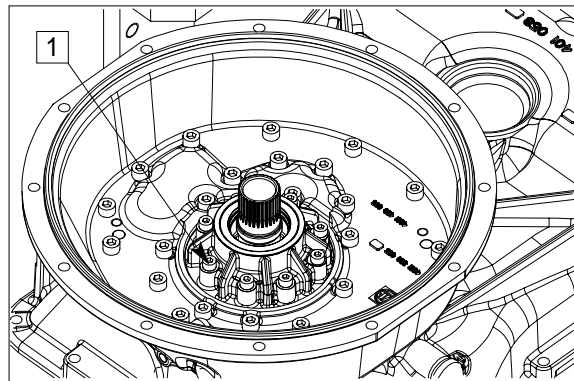

50DS7ETM233

- ⑬ Fix pump with cylindrical screws(1 and 2).

1 = M8 × 16

2 = M8 × 35

Tightening torque M8/8.8 × 16 ----- $M_A = 23\text{Nm}$

Tightening torque M8/8.8 × 35 ----- $M_A = 23\text{Nm}$

※ New cylindrical screws are to be fitted on a general basis.

※ These cylindrical screws are already provided with adhesive (microcapsule).

The microcapsule bursts when the screw is turned in, wets screw and nut thread and hardens.

Mount O-ring 30 × 3(1) onto the suction tube(2) and grease it.

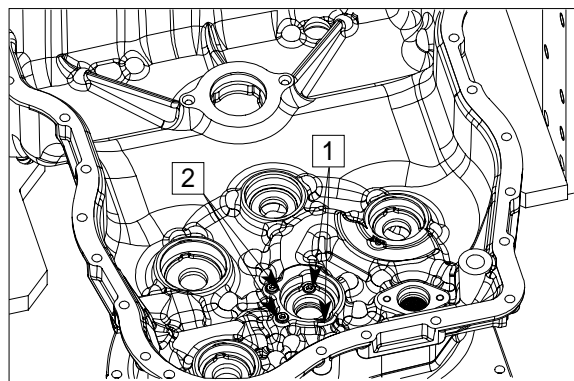

50DS7ETM234

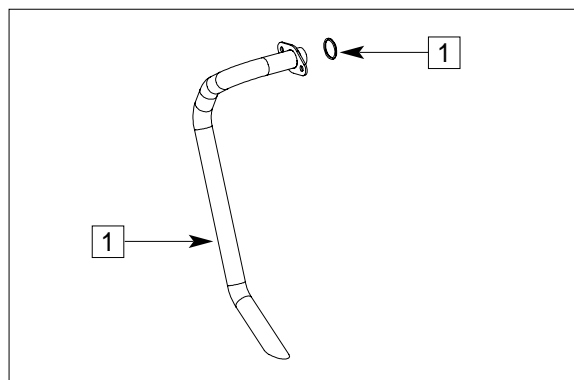

50DS7ETM235

- ⑭ Fix suction tube(1) with cylindrical screws $M8 \times 16(2)$.

Tightening torque $M8/8.8 \times 16$ ----- $M_A = 23Nm$

- ※ When reusing the cylindrical screws, they must be secured with Loctite no. 243.
- ※ New cylindrical screws are already provided with adhesive (microcapsule). The microcapsule bursts when the screw is turned in, wets screw and nut thread and hardens.

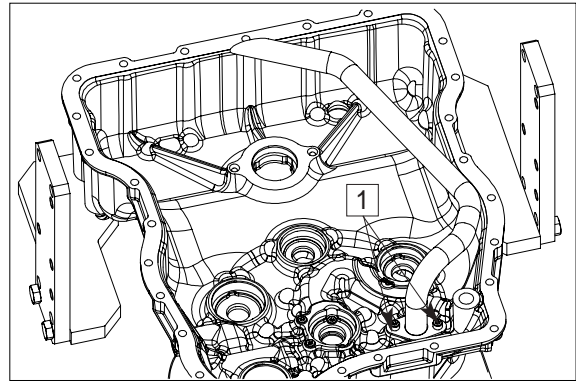

50DS7ETM236

- ⑮ Insert all bearing outer rings into the bearing holes of both housing parts(see figure TM236 and TM237).

1 = KV clutch - forward
 2 = KR clutch - reverse and input
 3 = KD clutch - 2nd gear
 4 = KC clutch - 1st gear
 5 = KE clutch - 3rd gear
 6 = Output

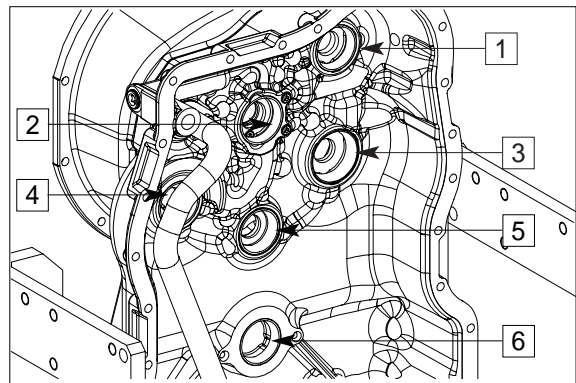

50DS7ETM237

- ※ Place bearing outer rings into the bearing holes using assembly grease.

- ※ If, contrary to the ZF recommendation, the tapered roller bearings of clutches and input are not replaced, it is imperative to ensure the previous pairing(bearing inner ring/bearing outer ring) - see page 3-78 TM40 and TM41.

- ⑯ Insert O-ring $24 \times 2.5(7)$ into the hole and grease it.

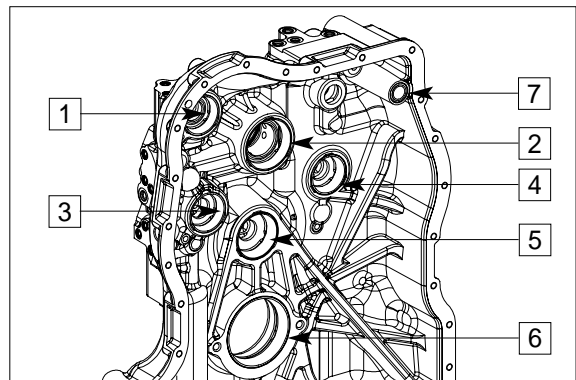

50DS7ETM238

(2) Reinstallation of clutches

- ① Align and grease rectangular ring 30×2 (1).

Position clutch KC(2).

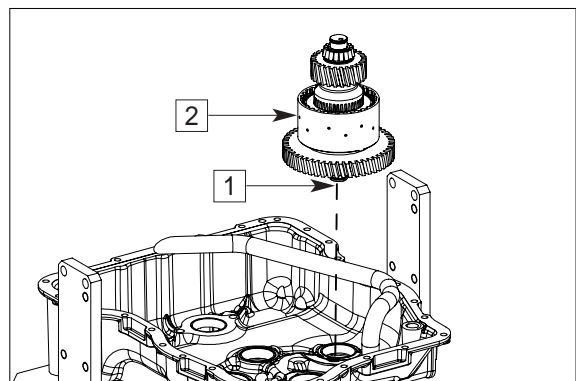

50DS7ETM239

- ② Align and grease rectangular ring 30×2 (1).

Position clutch KD(2).

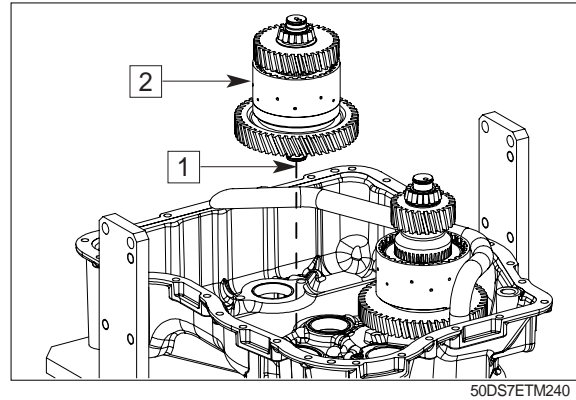

- ③ Align and grease rectangular rings 50×2.5 (1).

Position clutch KR- input(2).

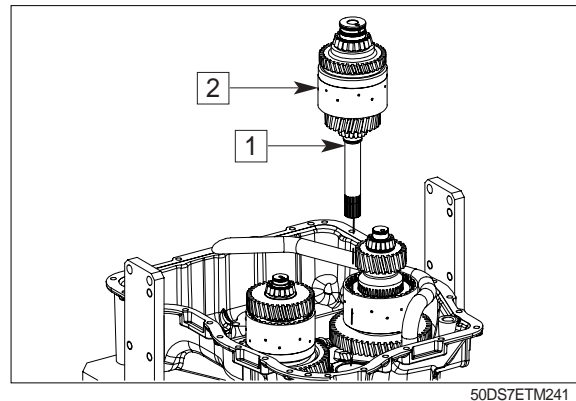

- ④ Align and grease rectangular ring 30×2 (1).

Position clutch KV(2).

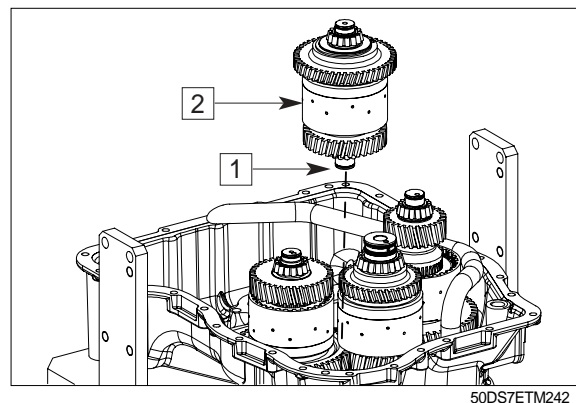

- ⑤ Position output shaft(1) together with screen sheet(2).

※ Bolts(3) of screen sheet must be fixed into the pilot holes.

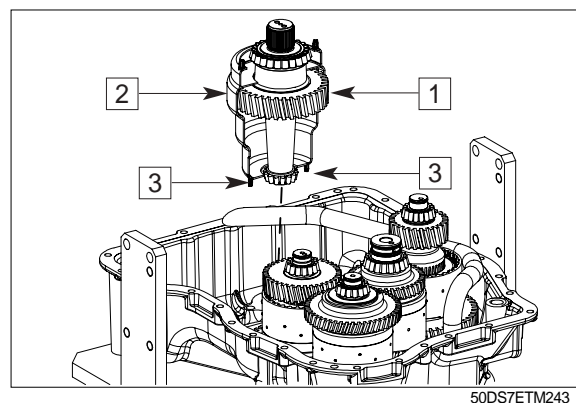

⑥ Align and grease rectangular ring 30×2 (1).

Position clutch KE(2).

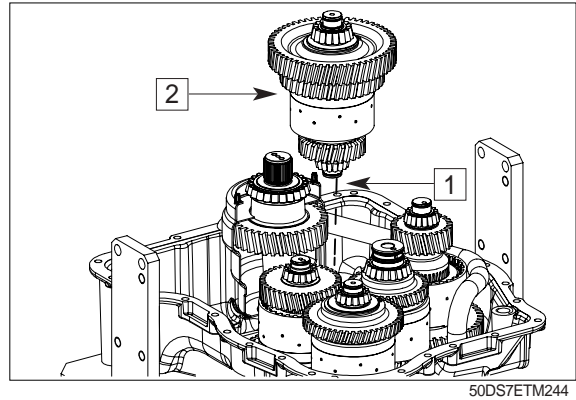

⑦ Align and grease rectangular rings(1).

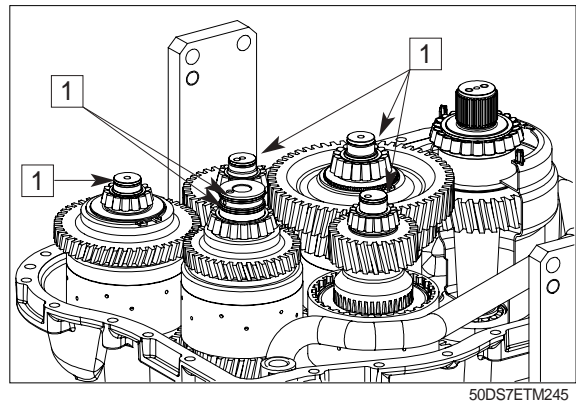

⑧ Use the lifting device to carefully bring the transmission housing rear part into contact position.

※ Bolts(1) of screen sheet must be fixed into the pilot holes.

※ Wet mounting face with Loctite (type no. 574).

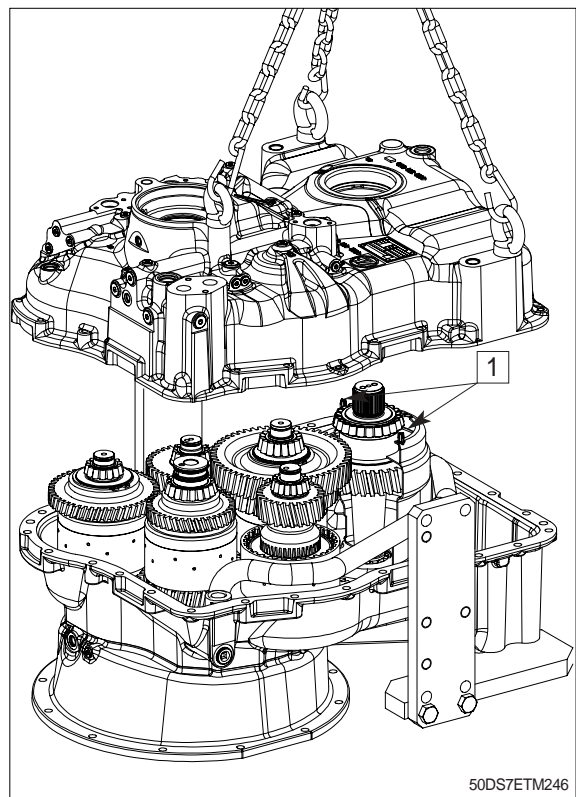

- ⑨ Hand-tighten the transmission housings crosswise with 2 cylindrical screws(1).

Fit cylindrical pins 12×24 (2) centrally to the mounting face.

Tighten the transmission housing front and rear part crosswise with 4 cylindrical screws M10(1).

Tightening torque ----- $M_A = 46\text{Nm}$

- ▲ Transmission rear part is not fixed to the holding fixture and could get loose after turning.

Secure the connection with cylindrical screws.

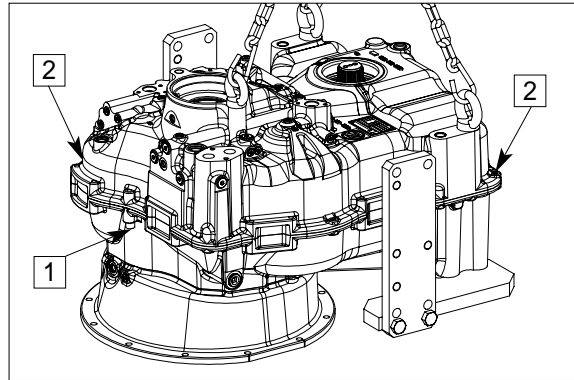

50DS7ETM247

- ⑩ Fix transmission housing front and rear part by means of cylindrical screws(1 and 2).

Fit bracket(3).

Cylindrical screws(1) M10 \times 30(11EA)

Cylindrical screws(1) M10 \times 50(17EA)

Tightening torque(M10/8.8 \times 30) $M_A = 46\text{Nm}$

Tightening torque(M10/8.8 \times 50) $M_A = 46\text{Nm}$

4 = cylindrical pin 12×24

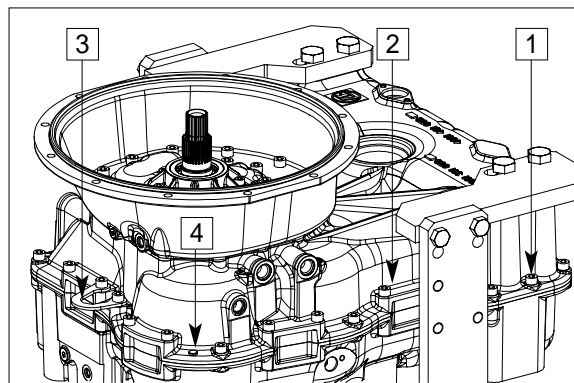

50DS7ETM248

3) REASSEMBLY OF OUTPUT FLANGE

- ① Use driver tool to fit the shaft seal 70 × 100 × 10(1) until contact position, with the sealing lip showing towards the oil sump.

(S) Driver tool 5870 048 057

- ※ Fill space between sealing lip and dust lip with grease.
- ※ Wet outer diameter with spirit.

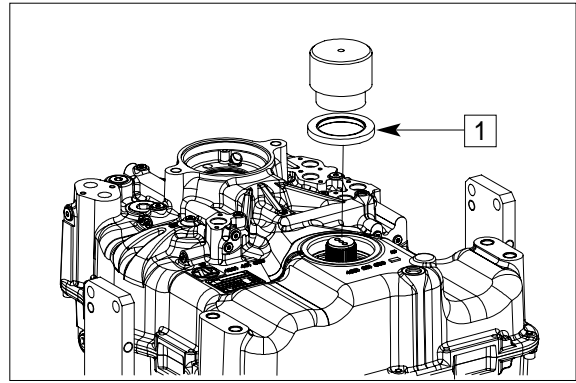

50DS7ETM249

- ② Heat up output flange (approx. 120°C).

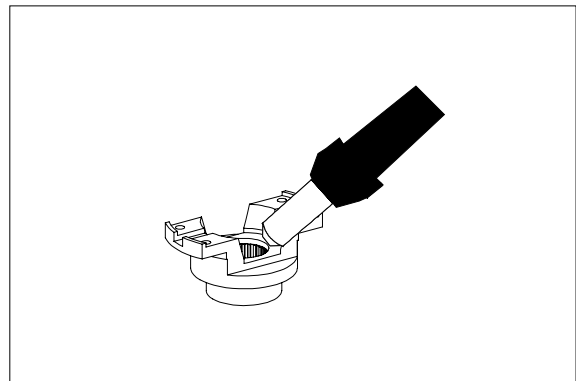

50DS7ETM250

- ③ Mount output flange (1) until contact is obtained.

⚠ Wear protective gloves.

- ※ Adjust output flange after cooling down.

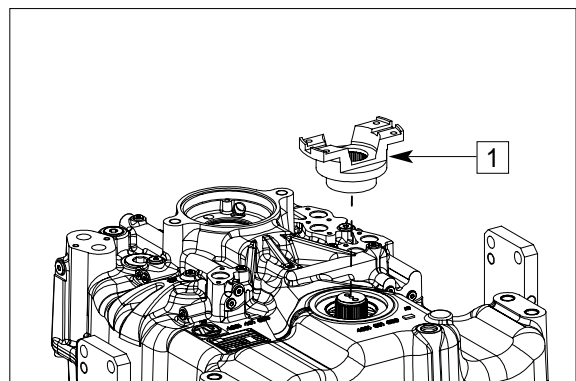

50DS7ETM251

- ④ Insert O-ring 38 × 4 into the space between output flange and shaft.

Fix output flange by means of washer (1) and hexagon screws 10 × 25 (2).

Tightening torque (M8/10.9 × 25) $M_A = 34\text{Nm}$

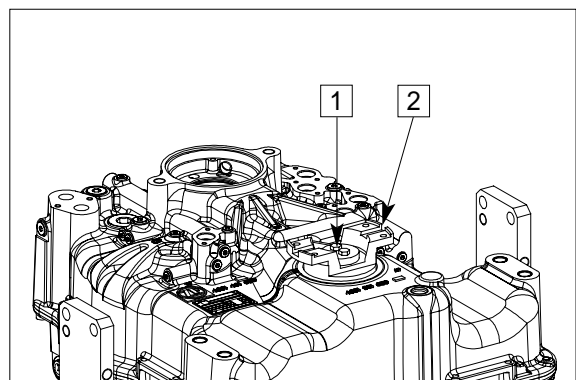

50DS7ETM252

4) REASSEMBLY OF CONVERTER SAFETY VALVE AND MAIN PRESSURE VALVE

(1) Reassembly of converter safety valve

- ① Insert valve(1) with drift(S) into the housing until contact is obtained.

(S) Drift 5870 705 012

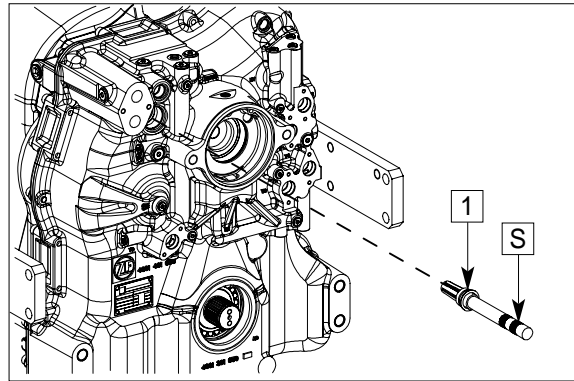

50DS7ETM253

- ② Place compression spring(1) into the transmission hole and fit screw plug M38 × 1.5(2) with O-ring 35 × 2(3).

Tightening torque $M_A = 46\text{Nm}$

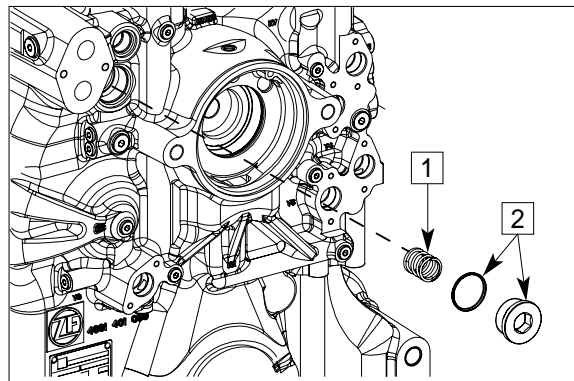

50DS7ETM33

(2) Reassembly of main pressure valve (control pressure valve)

- ① Main pressure valve consists of :
- 1 = Screw plug M22 × 1.5 with O-ring 19 × 2
 - 2 = Piston
 - 3 = Spacer ring(2 pcs)
Recommended value 5mm
 - 4 = Compression spring

※ The main pressure 16+3 bar is determined by means of the spacer rings.
Gradation of available spacer rings see parts manual.

Tightening torque $M_A = 60\text{Nm}$

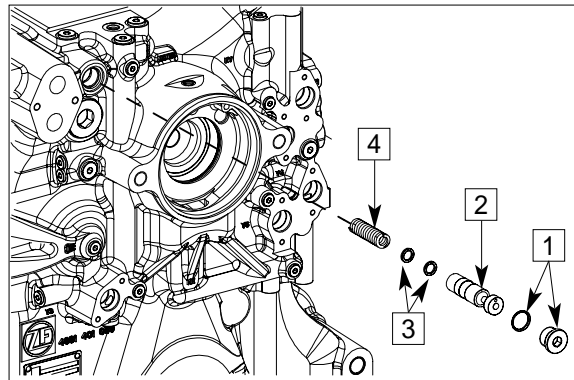

50DS7ETM32

5) REASSEMBLY OF CENTRAL SHAFT (PTO) AND CONVERTER

- ① Press tapered bearing(1) onto the central shaft(2) until contact is obtained.

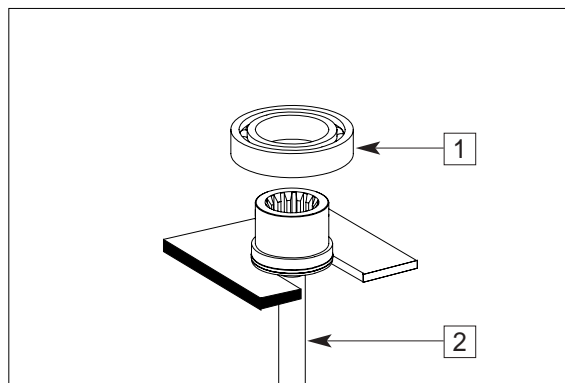

50DS7ETM254

- ② Press the toothed disk(1) onto the pump shaft until contact is obtained.

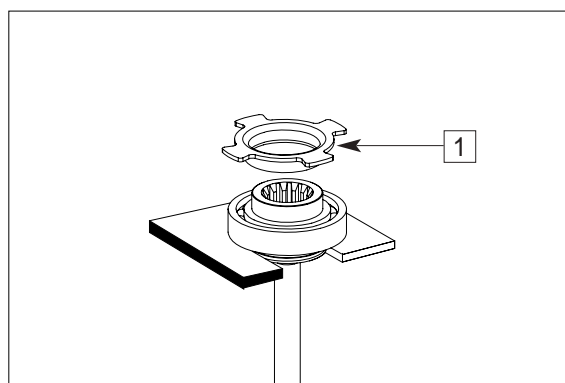

50DS7ETM255

- ③ Mount rectangular ring 50×2.5(1).

Grease and centrally align rectangular ring.

Mount retaining ring 75×2.5(2).

Mount central shaft(3) until contact is obtained.

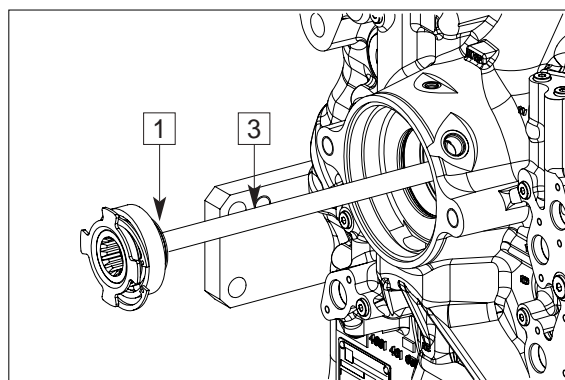

50DS7ETM256

- ④ Fix central shaft with retaining ring 75×2.5(1).

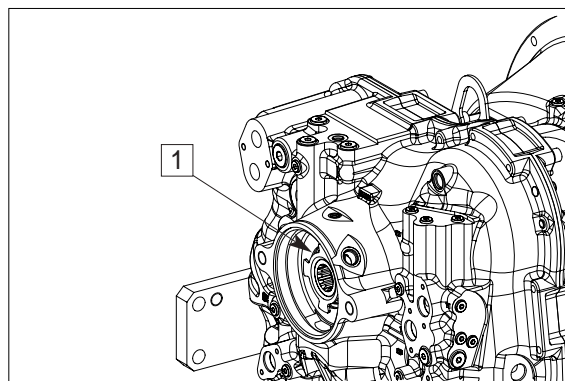

50DS7ETM257

- ⑤ Mount converter(1) until contact is obtained.

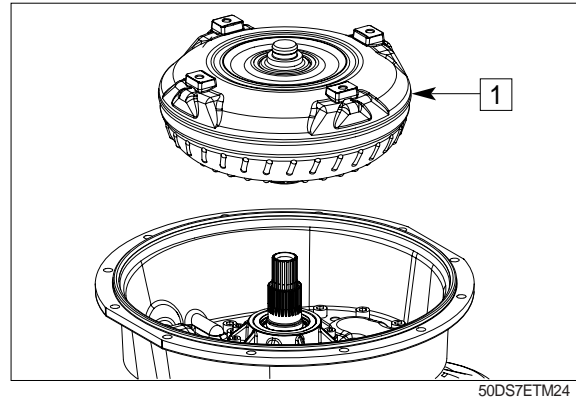

- ⑥ Position 1 washer(each/thickness= 1.0mm (4EA) (1) onto the flexplate mounting webs(4EA).

Place flexplates(2).

- ※ Pay attention to the installation position. Spot-welded reinforcing disks of the flexplate to be arranged towards the outside-see arrows.

Mount washer(3) to the hexagon screw M10×16(4) and fix the flexplates.

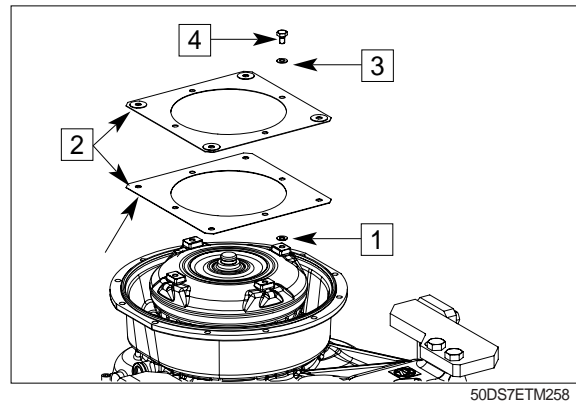

- ⑦ Tighten hexagon screws M10×16(1).

Tightening torque(M10/8.8×16) $M_A = 46\text{Nm}$

- ※ When reusing the hexagon screws they must be secured with Loctite 243.
- ※ New hexagon screws are already provided with adhesive (microcapsule). The microcapsule bursts when the screw is turned in, wets screw and nut thread and hardens.

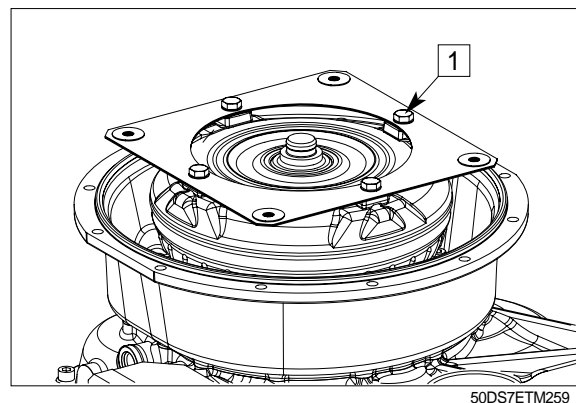

- ▲ Fix converter axially.
Risk of injury.

6) REASSEMBLY OF PRESSURE CONTROLLER (PROPORTIONAL VALVES), INDUCTIVE SENSOR, SPEED SENSOR(HALL SENSOR), TEMPERATURE SENSOR, BREATHER AND SCREW PLUGS

① Mount breather (1).

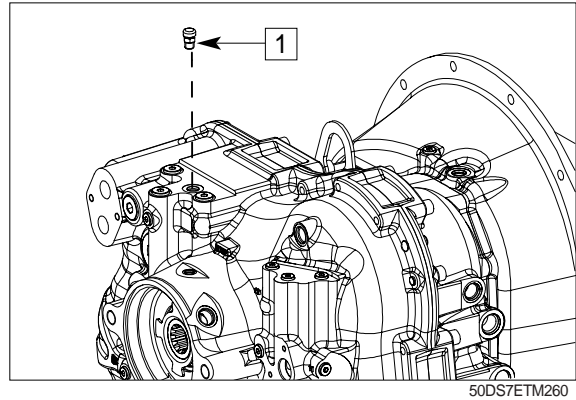

② Mount output Hall sensor-(1) onto the speed sensor, install O-ring 15.5×2.6(2) and fix it with cylindrical screws M8×16 (3).

Tightening torque(M8/8.8x16) $M_A = 23\text{Nm}$

- ※ When reusing the cylindrical screw, it must be secured with Loctite no. 243.
- ※ New cylindrical screw is already provided with adhesive(microcapsule). The microcapsule bursts when the screw is turned in, wets screw and nut thread and hardens.

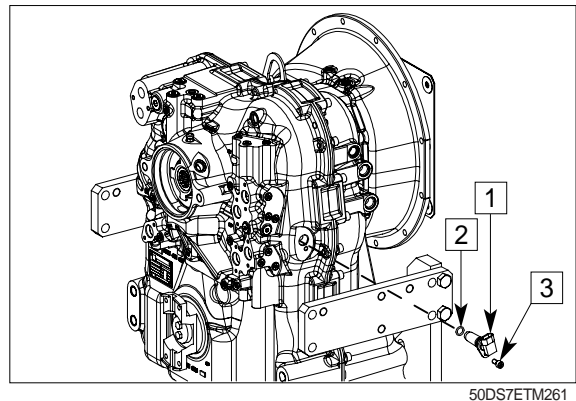

③ Fit positioned parts.

1 = Inductive sensor with O-ring 15×2
- n turbine

2 = Inductive sensor with O-ring 15×2
- n central gear chain

3 = Inductive sensor with O-ring 15×2
- n engine

Tightening torque $M_A = 30\text{ Nm}$

4 = Temperature sensor with O-ring 11×2
Measuring point "63" after the converter

Tightening torque $M_A = 25\text{Nm}$

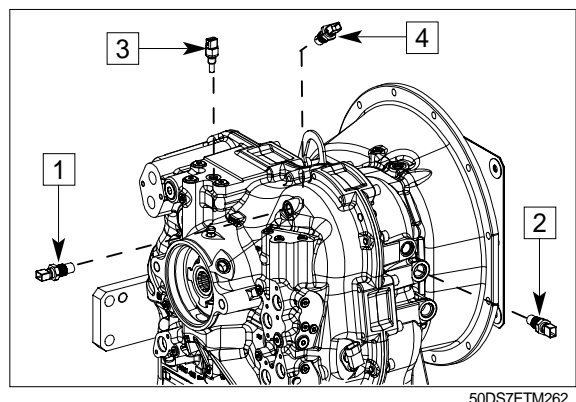

- ④ Fix pressure controller-proportional valves-(1) with the cylindrical screws M6x12(2).

Tightening torque(M6/8.8×12) $M_A = 9.5\text{Nm}$

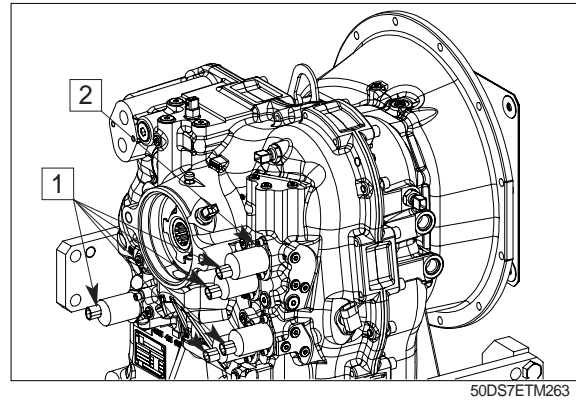

50DS7ETM263

- ⑤ Mount all screw plugs(1 and 2) with O-rings.

1 = Screw plug M10x1 with O-ring
8×1.5(24EA)

Tightening torque(M10×1) $M_A = 6\text{Nm}$

2 = Screw plug 9/16-18 UNF with O-ring
11.9×2(7EA)

Tightening torque(9/16-18 UNF) .. $M_A = 15\text{Nm}$

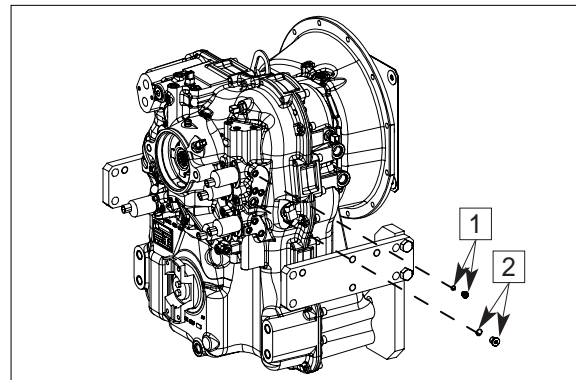

50DS7ETM264

7) REASSEMBLY OF FILTER, CLOSING COMPONENTS, OIL FILLER TUBE WITH OIL DIPSTICK AND OIL DRAIN PLUG

- ① Place O-rings 34.2×3(1) into the holes and grease them.

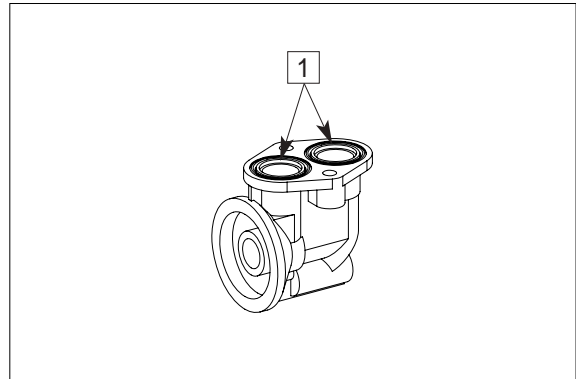

50DS7ETM265

- ② Attach filter head(1) with cylindrical screws M8x30 (2).

Tightening torque(M8/8.8×30) $M_A = 23\text{Nm}$

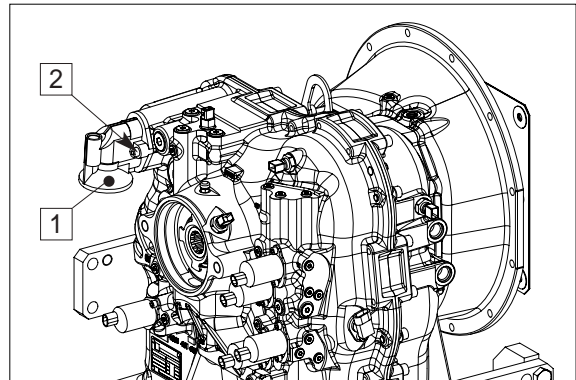

50DS7ETM266

- ※ The fine filter(1) has to be fitted as follows :

- Slightly oil the seal
- Turn in the filter until contact with the sealing surface is obtained, and then tighten it by hand with approx. 1/3 to 1/2 rotation.

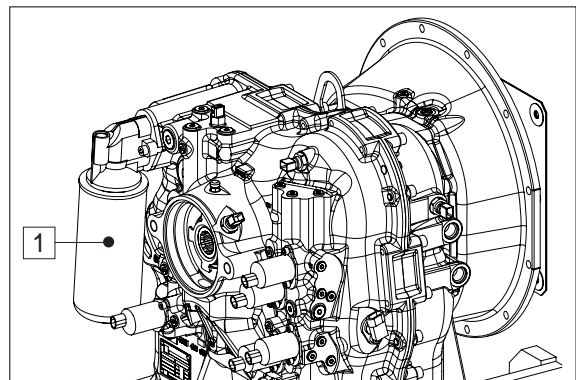

50DS7ETM267

- ③ Install O-ring 30×3(1) onto the oil suction tube(2), grease it and fix it with cylindrical screws M8×16(3) to the transmission housing.

Mount oil dipstick(4).

Tightening torque (M8/8.8×16) $M_A = 23 \text{ Nm}$

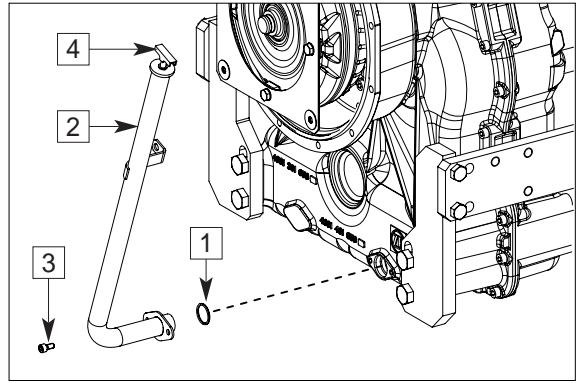

50DS7ETM268

- ④ Fit oil drain plug 7/8-14 UN 2A(1).

Tightening torque(7/8-14 UN 2A) $M_A = 30 \text{ Nm}$

Fix identification plate(2) by means of grooved pins 3×5.

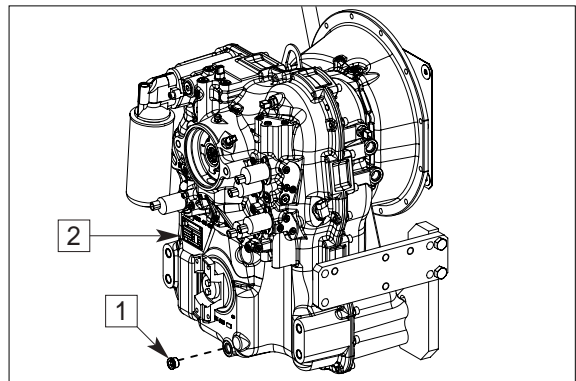

50DS7ETM269

- ※ Before putting the transmission into operation, fill it with oil according to Operator's Manual.

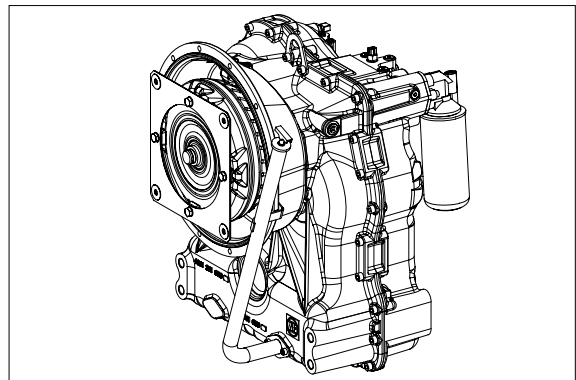

50DS7ETM270

3. DISASSEMBLY OF DRIVE AXLE

1) REMOVAL AND DISASSEMBLY OF WHEEL HUB

- (1) Loosen drain plug with a torque wrench(1) in axle housing and drain oil.



- (2) Loosen oil drain plug in planetary housing and drain oil.



- (3) Loosen 4 socket head bolts and remove the planetary carrier.



- (4) Remove O-ring (4) and snap ring (5) from the housing of planetary.



(5) Remove 3 pins(6) with a plastic hammer.



(6) Remove needle bearing(8), planet gear(7) and thrust washer(9).

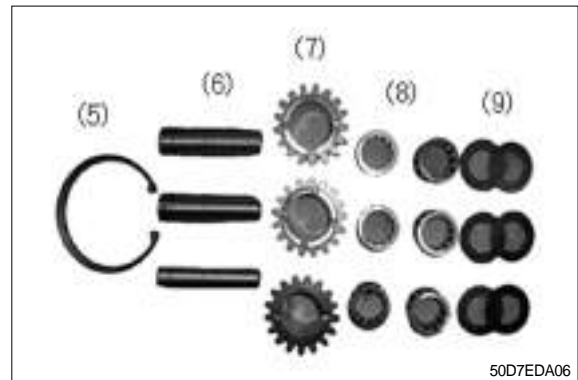

(7) Remove sun gear(10) and drive shaft(11).

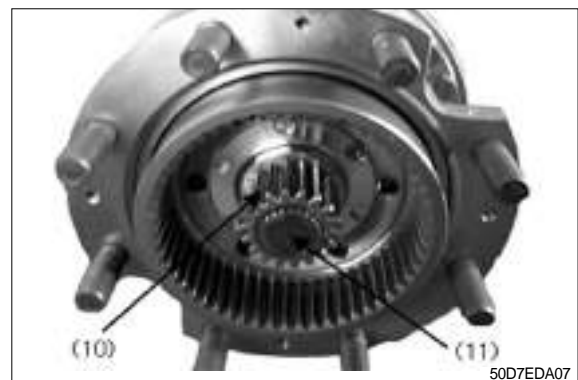

(8) Remove snap ring(12) and then remove sun gear(10) from the shaft(11).

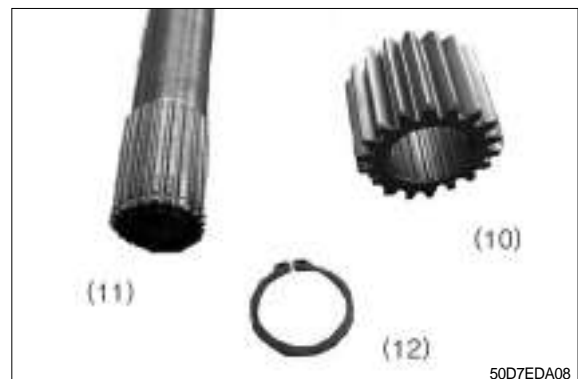

(9) After removing bolt(13), remove ring gear(14) and torque plate assembly(14) from the spindle.

※ **Must measure the rolling resistance of tapered roller bearing.**



(10) Remove C-ring (14) from the ring gear and pull the spindle (15) out of the ring gear.

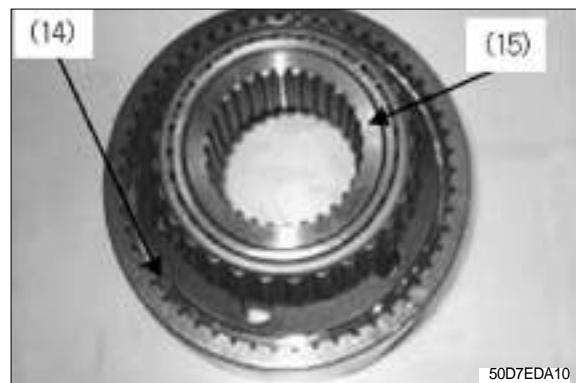

(11) Pull out bearing inner race on flange using 2 × M8 bolts.



(12) Remove wheel hub from the axle housing after loosen 14 bolt and 2 nut.



(13) Disassemble drive shaft and disc & plate assembly.

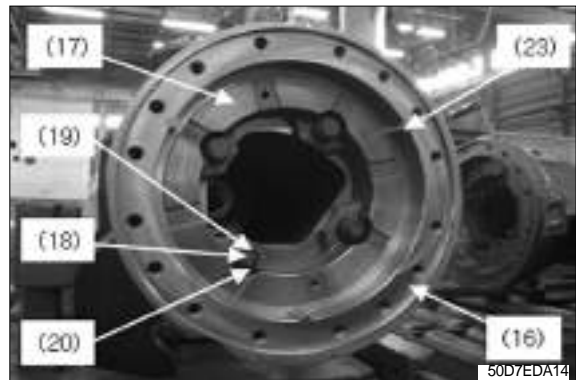

(14) After loosening 4 bolt-self adjust (18), disassemble spring-self adjust (20) from bushing-self adjust (19). Then disassemble piston (17) from axle housing (16). After checking 3 pins (23), then finally remove square ring (21, 22).

※ Do not reuse damaged square ring.

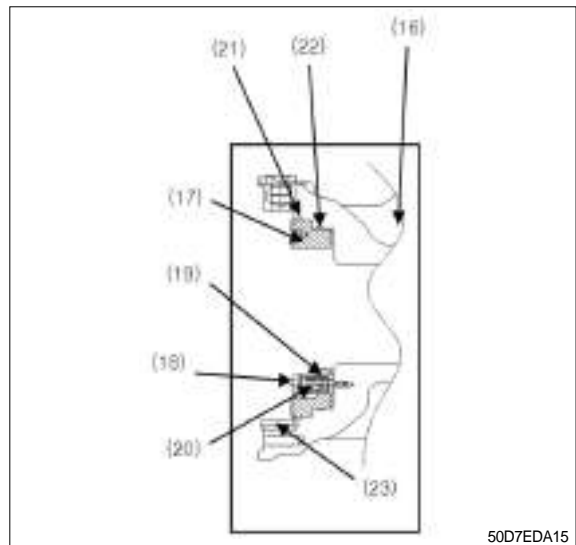

(15) Remove bearing cup from the wheel hub by using jig and hammer. Shaft seal may be damaged.



2) DISASSEMBLY OF THE DIFFERENTIAL CARRIER ASSEMBLY

(1) Loosen 12 bolts(1) and then remove carrier from the housing by using a lifting machine.



(2) For the reassembly, check rolling resistance and record it. After loosen 2 bolts(2) and then remove backing plate (3).

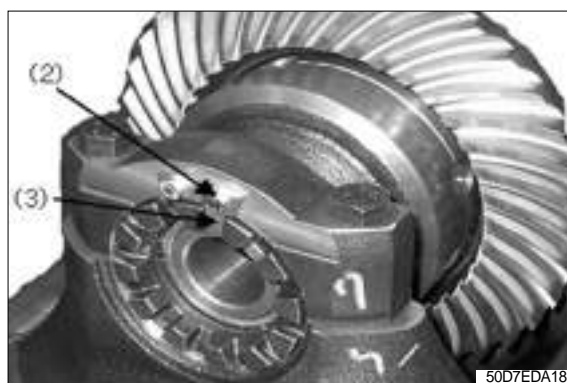

(3) Before removing differential assembly from carrier(4), check the location of cap(5) and mark it for reassembly.

(4) Remove 4 hexagon bolts(6) and cap(5).



(5) Remove differential assembly from the carrier.

(6) Disassemble bearing(6) from the differential housing and remove 12 bolts (7).



(7) After removing 12 mounting bolts(8) from the housing and then disassemble the ring gear.



(8) Check the mark on the housing and separate the housing from the differential. If there is no mark, be sure to mark on the housing. When reassembling, it must be placed at the same position as before.



(8) Remove thrust washer, side gears, pinion gears and spider and then place them on the clean place.



(10) Loosen 4 bolts (10) and then remove the drum from the parking brake.



(11)After removing lock nut(11) and then remove the yoke(12).

(12)Loosen 4 bolts (13) and then remove parking brake (14) from the carrier housing.

(13)Remove the drive bevel pinion shaft (15) carefully using a plastic hammer.

※ **Be careful not to damage bevel pinion shaft.**

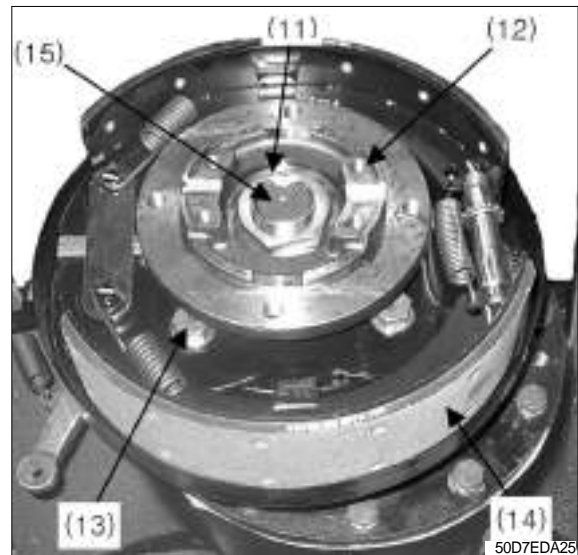

(12)Remove shim(16) and spacer(17) from pinion shaft.

Using a bearing puller, disassemble inner race of taper roller bearing from the pinion shaft.

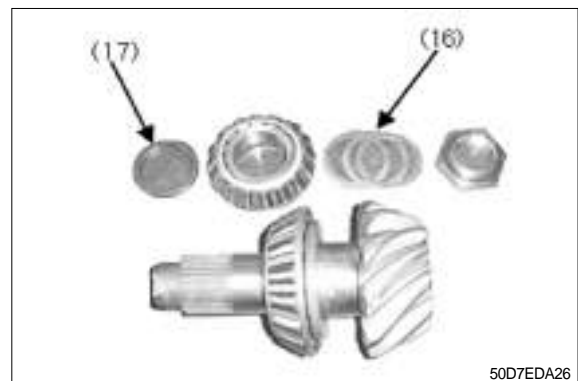

(13)Remove outer race of taper roller bearing and shim from the housing by using a jig and hammer.

※ **Do not reuse damaged shims.**



(14)Remove outer race of taper roller bearing on the opposite side.



4. REASSEMBLY OF DRIVE AXLE

Clean every parts with cleaner and then remove remained loctite.

- ※ **Be careful not to spill cleaner on your body.**
Avoid drinking cleaner or breathing its fumes.
Wear protective clothing, glasses and gloves.
If spilled on the skin, flush your skin with water immediately.
If swallowed, get medical attention immediately.
- Check wear, damage or crack for all the parts and replace if needed.
- If the teeth of gear are damaged, replace it as a set.
- Replace damaged tapered roller bearing.
- Do not reuse deformed shims or worn thrust washers.
- Polish the surface on which seal contacted if needed.

1) ADJUSTMENT OF BEVEL PINION SHAFT

Adjusting shims of bevel pinion shaft.

(1) Adjust shim thickness for the bevel pinion shaft with following method.

- ① Measure "E" distance on the housing.
- ② By the equation " $X = E - B - T \pm C + 0.25$ ", define the shim thickness(1).

B : Mounting dimension of bevel pinion shaft , 131.10mm (5.2 in)

T : Height of bearing.

C : Dimension of carved seal on the pinion. If there's no carved seal **C=0**.

EX) : From the housing

"E" = 162.85mm (6.4in)

B is factory dimension

"B" = 131.10mm (5.2in)

Front the bearing

"T" = 31.75mm (1.5in)

Carved seal on the pinion

"C" = 0.05mm (0.002in)

Shim thickness :

"X" = $162.85 - 131.10 - 31.75 + 0.05$
= 0.45mm (0.022in)

- ※ **If teeth are damaged, replace it as a set (bevel gear and shaft).**
Do not reuse damaged shims and bearings.

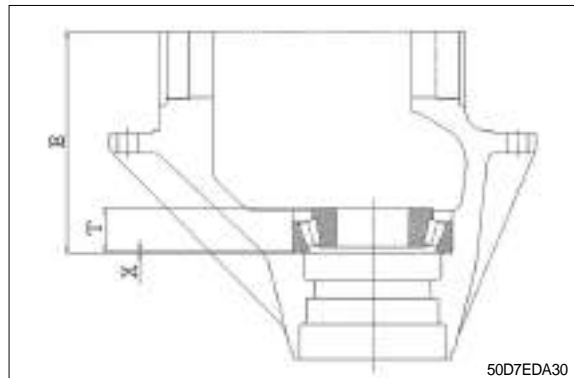

(2) Using different kinds of shims, adjust shim thickness as measured by previous equation. Place shims at the bearing place.

Using a jig, assemble drive bearing so that the outer race contact with the bearing place.



(3) Heat inner race of bearing to max 100°C and then assemble it to the pinion shaft. Also inner race should contact with bearing place.

• **Measuring play of bevel pinion shaft end**
Measure shim thickness by following method.

Dimension "Q" : Distance from bearing outer race surface to spacer surface.

Dimension "S" : Distance from bearing outer race surface to inner race surface.

From the below equation, define required shim thickness Z.

$$" Z = S + Q "$$

EX) : From the bearing

$$S = 2.25\text{mm (0.09in)}$$

From the housing

$$Q = 3.15\text{mm (0.12in)}$$

Needed shim thickness Z :

$$Z = 2.25 + 3.15 = 5.40\text{mm (0.21in)}$$

Unit : mm(in)

P	Q	Z
2.25(0.089)	3.15(0.124)	5.40(0.213)
2.30(0.091)	3.15(0.124)	5.45(0.215)
2.35(0.093)	3.15(0.124)	5.50(0.217)
2.40(0.094)	3.15(0.124)	5.55(0.219)
2.45(0.096)	3.15(0.124)	5.60(0.220)

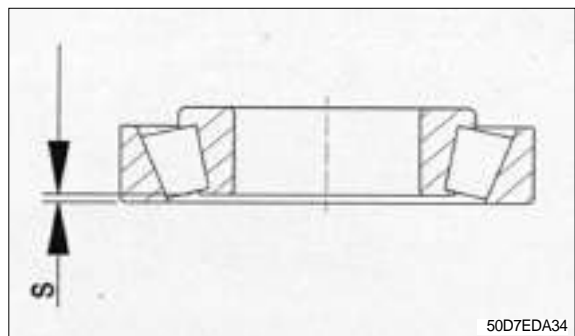
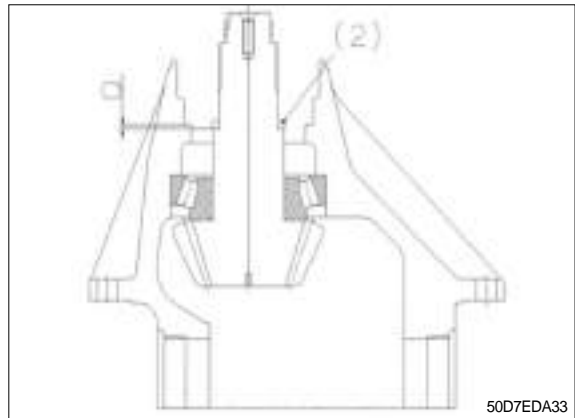

2) ADJUSTMENT OF PINION SHAFT

(1) Assemble bearing cup.

Assemble spacer to the pinion shaft and then install measured shims onto the spacer.



(2) Insert pinion shaft into the carrier.

Assemble bearing cone and lock nut.
Apply grease on the outer bearing.

Apply loctite #271 or #277 on the thread of pinion and then tighten lock nut.

- Tightening torque : 45~51kgf · m
(325~369lbf · ft).

Measure rolling resistance of pinion shaft.

- Rolling resistance : 0.20~0.41kgf · m
(1.4~2.9lbf · ft).

Coke lock nut into the pinion shaft slot.



3) ASSEMBLY OF DIFFERENTIAL ASSEMBLY

- (1) Assemble thrust washer, side gear and spider with gears and then install them to the differential housing.

Apply grease on the bevel gear and thrust washer.



- (2) Assemble differential housing.

※ **Check marks on the housing.**
Match two marks at the same position.



- (3) Tighten 12 bolts(1) to the differential housing.

Apply loctite #271 or #277 on the thread of bolt.

- Tightening torque : 5.0~7.5kgf · m
(36~54lbf · ft)



- (4) Assemble ring gear by tightening 12 bolts(2).

Apply loctite #271 or #277 on the thread of bolt.

- Tightening torque : 12.5~14.5kgf · m
(90~105lbf · ft)



- (5) Install differential assembly into the carrier.
Place the bearing cup and screw into the housing. At this moment, using a screw adjust rotation backlash.
Install the dial gauge on the gear tooth and measure the backlash while rotating bevel gear.

- Rotation backlash : 0.18~0.23mm
(0.007~0.009in)



- (6) Assemble bearing cap.

※ **Fix bearing cap with hexagon bolt.**

- Tightening torque : 15.0~17.0kgf · m
(108~123lbf · ft)

Measure rolling resistance of tapered roller bearing.

The following table shows the relation between preload(P) of bevel pinion shaft and rolling resistance(Z).
(calculated at adjustment of pinion shaft ②).

Unit : kgf · m (lbf · ft)

P	Z
0.20(1.45)	0.30~0.36(2.17~2.60)
0.25(1.81)	0.35~0.41(2.53~2.97)
0.30(2.17)	0.40~0.46(2.89~3.33)
0.35(2.53)	0.45~0.49(3.25~3.54)

- (7) Confirm that the screw contacts to the bearing.
- (8) After complete assembly of bearing, measure rotation backlash once more and readjust with a screw if needed.
- (9) Apply loctite #271 to the thread of bearing cap bolt and then assemble it with tightening torque of 15.0~17.0kgf · m(108~123lbf · ft).
- (10) Assemble plate with hexagon bolts. Apply loctite #271 or #277 to the tapped side of bolt and then assemble it with tightening torque of 0.80~1.20 kgf · m(5.8~8.7lbf · ft).
- ※ **Assemble opposite side with the same methods.**
- (11) Apply marking liquid on 3~4 teeth of the ring gear and then rotate pinion gear to check gear contact. Check out the contacted shape.

4) ASSEMBLING CARRIER

- (1) Assemble carrier assembly into the axle housing.
- (2) Fix the carrier assembly with hexagon bolt (1). Apply loctite #271 or #277 to thread of bolt and then assemble it with tightening torque of 11~13kgf · m(79.6~94.0lbf · ft).



- (3) Assemble brake drum to yoke with tightening 4 bolts (2).
Apply loctite #271 or #277 to thread of bolt and then assemble it with tightening torque of 11~13kgf · m(79.6~94.0lbf · ft).
- (4) Close hole (3) with rubber plug.

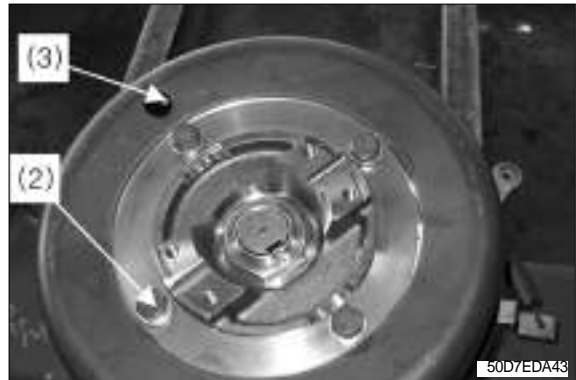

5) ADJUSTMENT OF PARKING BRAKE

- (1) The following procedures should be applied for brake shoe adjustment.
 - ① Open rubber plug on (2).
 - ② Adjuster should be turned according to arrow direction until occurring drum drag.
 - ③ Adjuster should be turned opposite direction of the arrow sign by four click.
At that case, lining clearance is 0.1~0.25 mm.
 - ④ Check drum drag after operating lever several times.
(Repeat from beginning if drag is occurred)

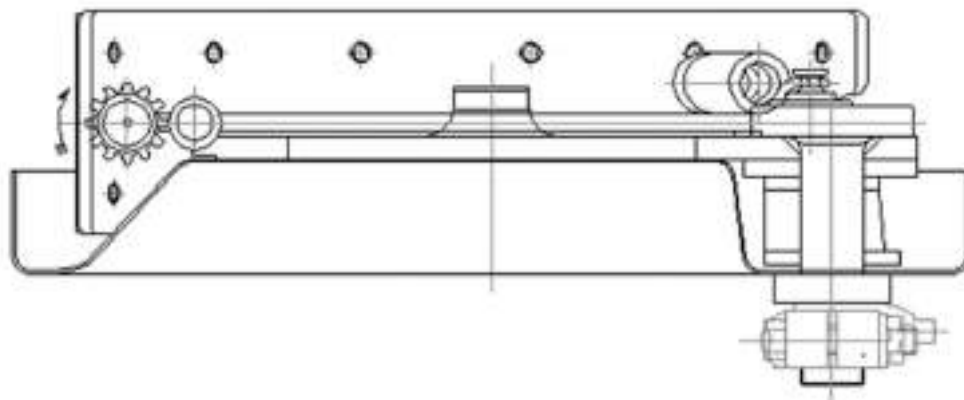

50D7EDA44

6) ASSEMBLING WHEEL HUB ASS'Y

(1) Insert bearing into wheel hub.

- ※ Apply grease or oil to shaft seal and then assemble it with proper direction (outer side of wheel hub).



(2) Install wheel hub assembly to the spindle completely.



(3) Insert the spindle into ring gear and secure with circlip.



(4) Place heated tapered roller bearing inner race into the spindle until contact take places. Install it on the wheel hub after cooling down.



- (5) Install the torque plate to fix the spindle.
Apply loctite #5127 to axle housing surface which contact to the spindle.



- (6) Assemble square ring(2), (3) to the axle housing(1) then apply the oil (Mobilfluid #424). Assemble bushing(5) to piston (2) and then assemble piston (2) to axle housing after applying oil sufficiently and then assemble the spring (6) to the bushing (5).

Also, apply loctite #271 to 4 bolts(7) then assemble them with tightening torque 14~16kgf · m(101.3~115.7lbf · ft).

Assemble 3 brake pins(8) to axle housing.

- ※ Check the status of square ring and replace if damaged.

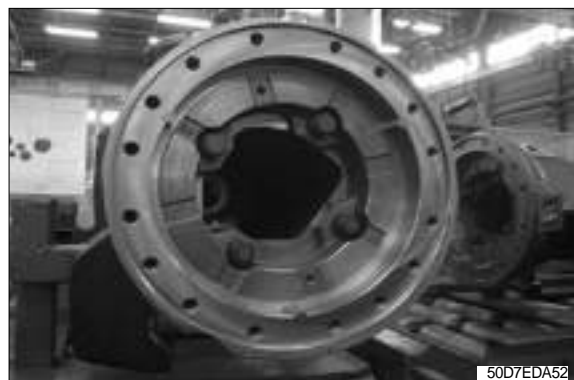
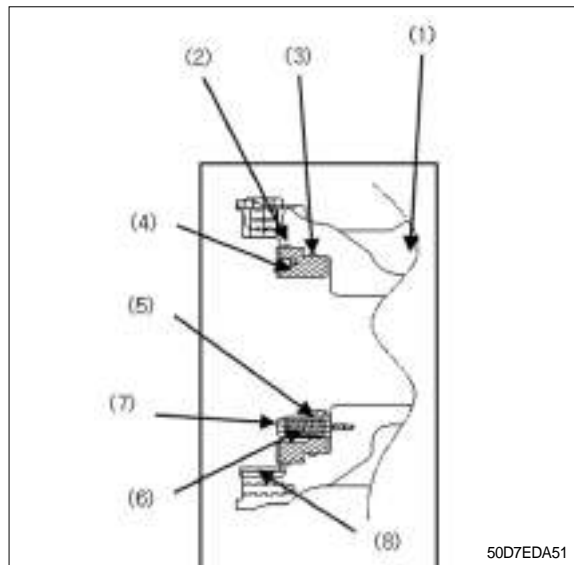

Assembling plate and inspection

- ① Assemble 5 plates(9) and 4 disks(10) with spline collar(11) and then lock with snap ring (12).
 - Disc must be assembled after the oil immersion during 12 hours. (Mobilfluid #424)
- ② Install assembled spline collar to the axle housing with the drive shaft.
 - Before assembling, clean all of the parts completely and remove burrs.
- ③ After assembling, confirm that the clearance between the outer plate and the axle housing surface is 2.1~2.6mm (0.08~0.10in).

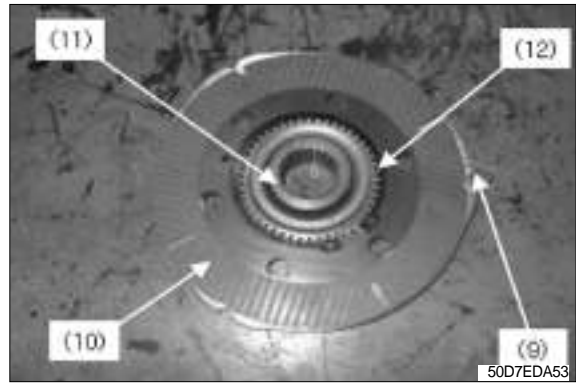

- (7) Push pre-assembled wheel hub to the axle housing until contact take places.



- (8) Tighten the torque plate until the wheel hub assembly has the same rolling resistance as before.
Apply loctite #271 or #277 to thread of bolt (13) and then assemble it with tightening torque of 18~22kgf · m(130.2~159.1lbf · ft).



- (9) After assemble sun gear to axle shaft and fix it with a snap ring.
Apply grease on the shaft where bushing contacts.
Apply grease on teeth of the planetary gear.



- (10) Assemble internal components of planetary carrier with the reverse order of disassembly.

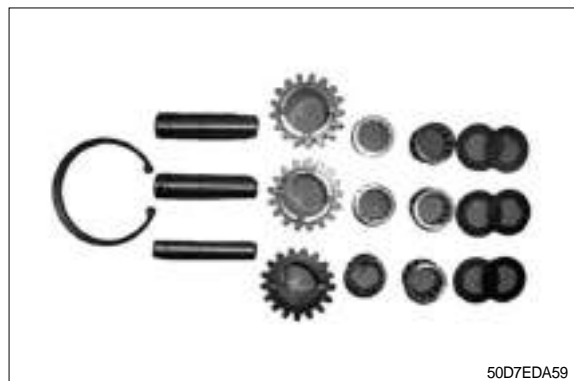

- (11) Install planetary carrier assembly to wheel hub and tighten bolt (2).
· Tightening torque : 25~40kgf · m
(180.9~289.3lbf · ft).



(12) Assemble wheel hub and tighten plug(14).

- Tightening torque : 35~60kgf · m
(253.2~434.0lbf · ft).

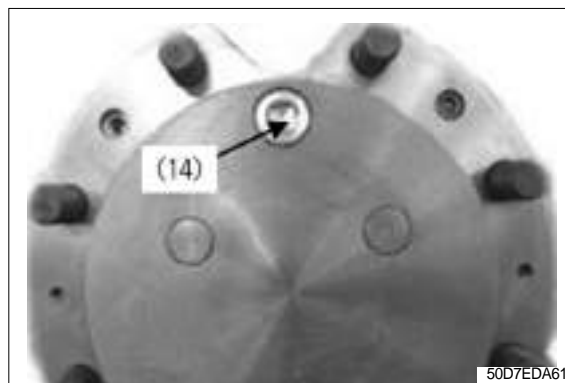

GROUP 4 ADJUSTMENT

1.CHECKING THE RING GEAR BACKFACE RUNOUT

Runout specification : 0.20mm(0.008-inch)
maximum

- 1) Attach a dial indicator on the mounting flange of the carrier.
- 2) Adjust the dial indicator so that the plunger or pointer is against the back surface of the ring gear.
- 3) Set the dial indicator to zero(0).
- 4) Rotate the ring gear and read the dial indicator. The runout must not exceed 0.20mm(0.008inch).

If runout exceeds specification, remove the differential and ring gear assembly from the carrier. Refer to "Disassembling the differential carrier assembly".

- 5) Check the differential parts, including the carrier, for problems that may cause the ring gear runout to exceed specifications. Repair or replace parts.
- 6) Re-install the differential and ring gear into the carrier. Refer to "Assembling the differential case".
- 7) Repeat the preload adjustment of the differential bearings.

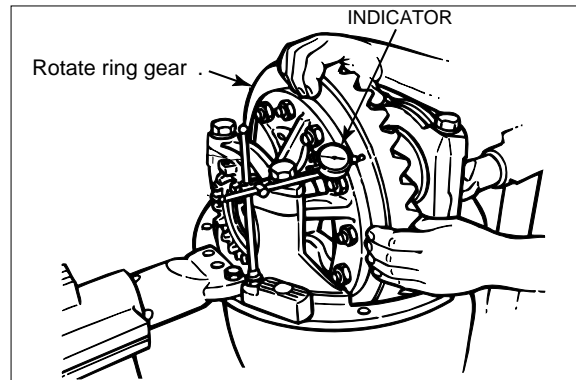

D507AX53

2. ADJUSTING THE GEARSET BACKLASH

Backlash specification : 0.13~0.18mm
(0.005-0.007inch)

If the old gearset is installed, adjust the backlash to the setting that was measured before the carrier was disassembled.

If a new gearset is installed, adjust the backlash to the correct specification for new gear sets.

- 1) Attach a dial indicator on the mounting flange of the carrier.
- 2) Adjust the dial indicator so that the plunger or pointer is against the tooth surface, near the heel end of the gear tooth. Set the indicator dial to zero(0).
- 3) Hold the drive pinion in position.
- 4) Read the dial indicator, while rotating the ring gear a small amount in both directions, against the drive pinion teeth.
 - ※ When you adjust backlash, move the ring gear ONLY. DO NOT move the drive pinion.
- 5) If the backlash reading is within specification, continue checking tooth contact patterns. Otherwise, adjust backlash. Refer to step 6), and check, following steps 1)-4).
 - ※ Backlash is increased by moving the ring gear away from the drive pinion. Backlash is decreased by moving the ring gear toward the drive pinion.
- 6) Loosen one bearing adjusting ring one notch, then tighten the opposite ring the same amount.

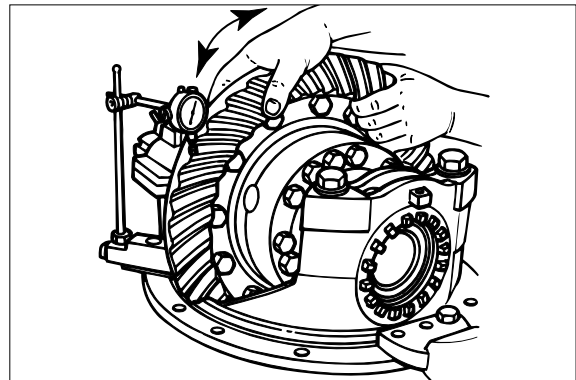

D507AX54

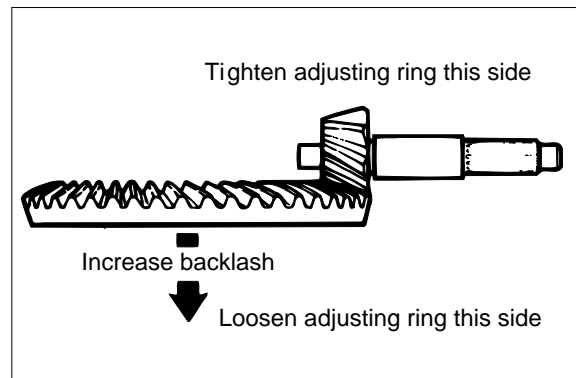

D507AX55

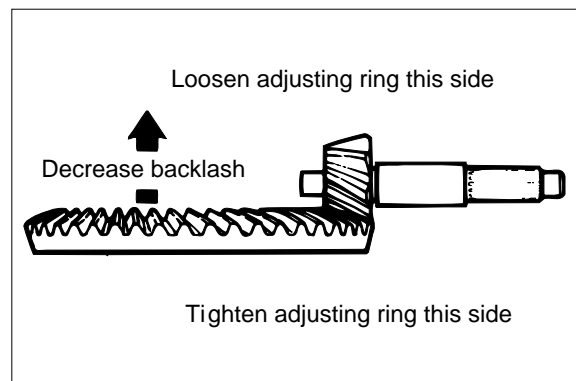

D507AX56

3.ADJUSTING TOOTH CONTACT PATTERN OF THE GEARSET

Always check tooth contact pattern on the drive side of the gear teeth.

- 1) Apply marking compound to approximately 12 teeth of the ring gear.

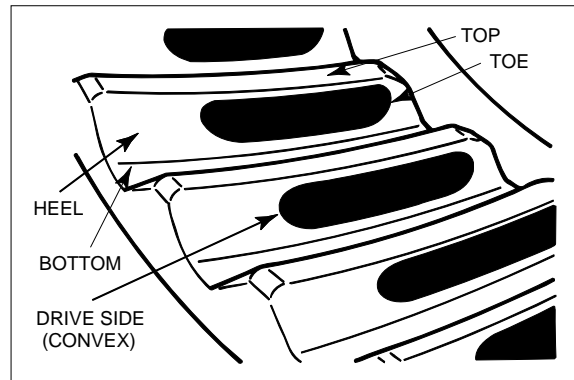

D507AX57

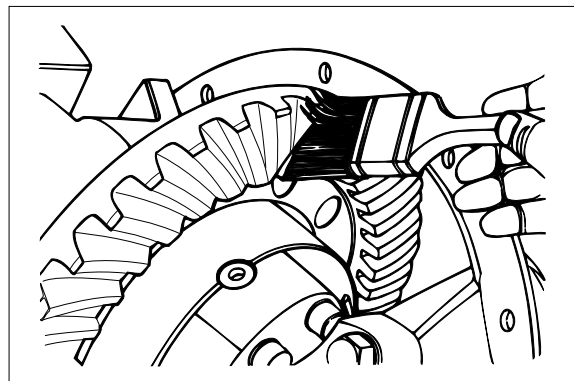

D507AX58

- 2) Rotate ring gear forward and backward so that the 12 marked teeth go past the drive pinion six times to get a good contact pattern.

- 3) Compare the contact patterns.

In new gearsets, a good contact pattern is toward the toe of the tooth, and centered between the top and bottom of the tooth.

In used gearsets, a good contact pattern fills approximately the full length of the tooth. The top of the pattern is near the top of the tooth. The location should match the wear pattern on the tooth.

If the contact patterns require adjustment along the width of tooth(top/bottom), follow steps 4)-5).

If the contact patterns requires adjustment along the length of tooth(toe/heel), follow step 6)-7).

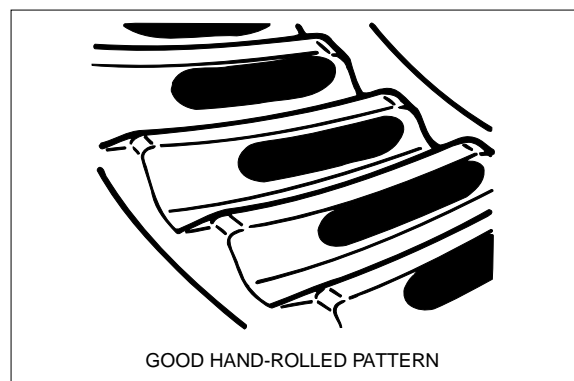

D507AX59

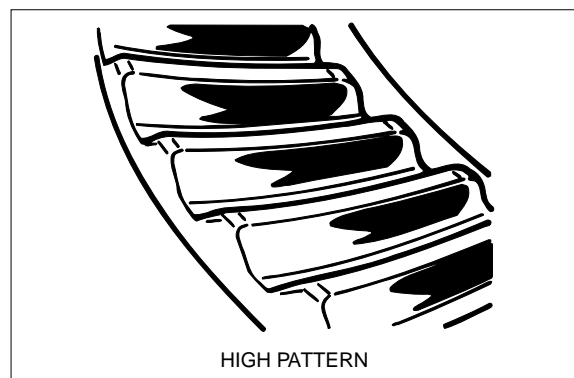

D507AX60

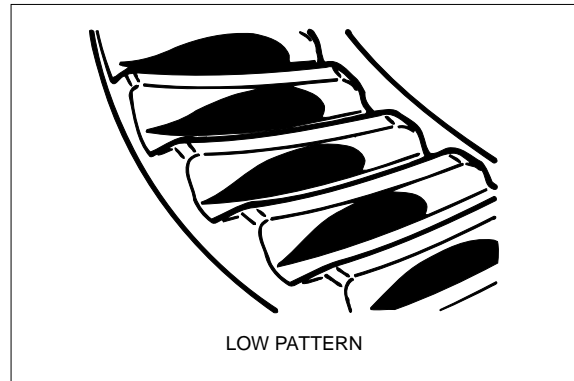

D507AX61



D507AX62

4) **High pattern** : A high contact pattern indicates that the pinion was installed too shallow into the carrier.

To correct, move the pinion toward the ring gear by decreasing the shim pack between pinion spigot and inner bearing cone. Refer to "Assembling the pinion bearing cage".

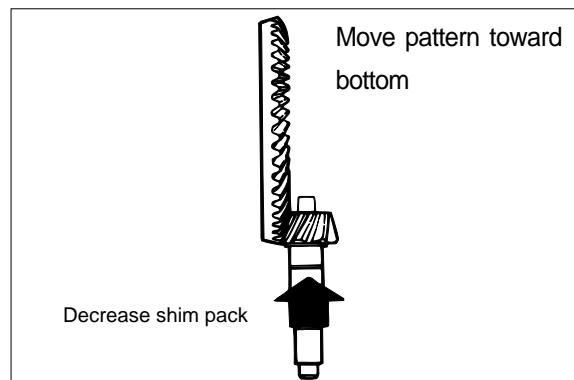

D507AX63

5) **Low pattern** : A low contact pattern indicates that the pinion was installed too deep into the carrier.

To correct, move the pinion away from the ring gear by increasing the shim pack between pinion spigot and inner bearing cone. Refer to "Assembling the pinion bearing cage".

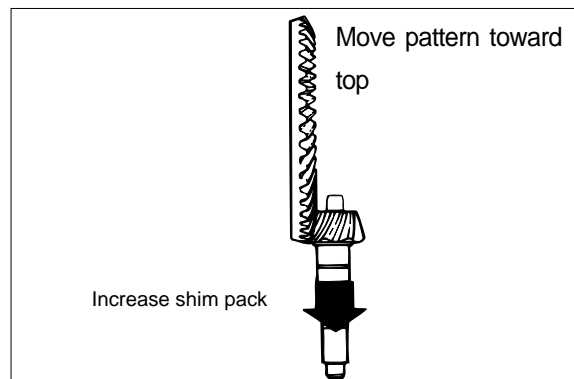

D507AX64

6) **Heel pattern** : Decrease the gearset backlash (within specified range) to move contact pattern toward toe and away from heel.

Refer to "Adjusting the gearset backlash".

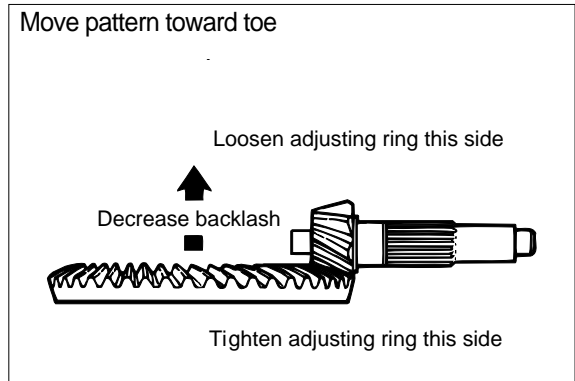

7) **Toe pattern** : Increase the gearset backlash (within specified range) to move contact pattern toward heel and away from toe.

Refer to "Adjusting the gearset backlash".

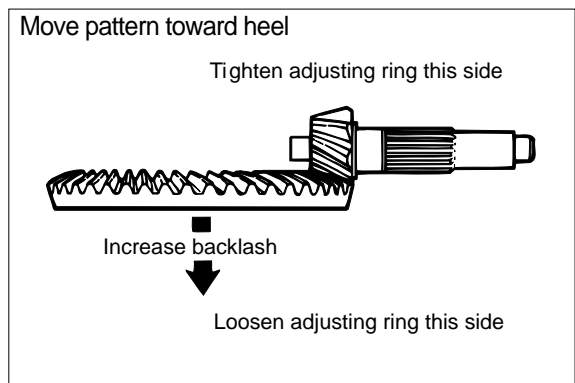

SECTION 4 BRAKE SYSTEM

GROUP 1 STRUCTURE AND FUNCTION

1. OUTLINE

- ※ The brakes are operated by a pressure compensated, closed center hydraulic system.
Flow is supplied by a fixed displacement, gear type brake pump.

BRAKE SYSTEM

The fixed displacement brake pump supplies flow to the cut-off valve for service brake circuit. It flows to two accumulator. The accumulator has a gas precharge and an inlet check valve to maintain a pressurized volume of oil for reserve brake applications.

Oil through the accumulator flows to the brake valves. The brake valve is a closed center design, dual circuit operated by a pedal.

The brake system contains the following components:

- Hyd pump
- Cut-off valve
- Brake valve
- Accumulators
- Pressure switches

PARKING SYSTEM

In the hand (parking) brake system, the brake shoes are expanded by operating the brake lever. Force from the lever is transmitted to the brake shoes through the hand brake cable and lever arm in drum brake assembly on the drive axle.

FULL POWER HYDRAULIC BRAKE SYSTEM

ADVANTAGES - The full power hydraulic brake system has several advantages over traditional brake actuation systems. These systems are capable of supplying fluid to a range of very small and large volume service brakes with actuation that is faster than air brake systems. Figure represents a time comparison between a typical air/hydraulic and full power hydraulic brake actuation system.

Full power systems can supply significantly higher brake pressures with relatively low reactive pedal forces. The reactive pedal force felt by the operator will be proportional to the brake line pressure being generated. This is referred to as brake pressure modulation.

Another key design feature of full power systems is the ability to control maximum brake line pressure. In addition, because these systems operate with hydraulic oil, filtration can be utilized to provide long component life and low maintenance operation.

Because these systems are closed center, by using a properly sized accumulator, emergency power-off braking that is identical to power-on braking can be achieved. These systems can be either dedicated, where the brake system pump supplies only the demands of the brake system or non-dedicated, where the pump supplies the demands of the brake system as well as some secondary down stream hydraulic device.

Another important note is that all seals within these system must be compatible with the fluid medium being used.

**Response time
Full power brake actuation VS
Air/Hydraulic brake actuation**

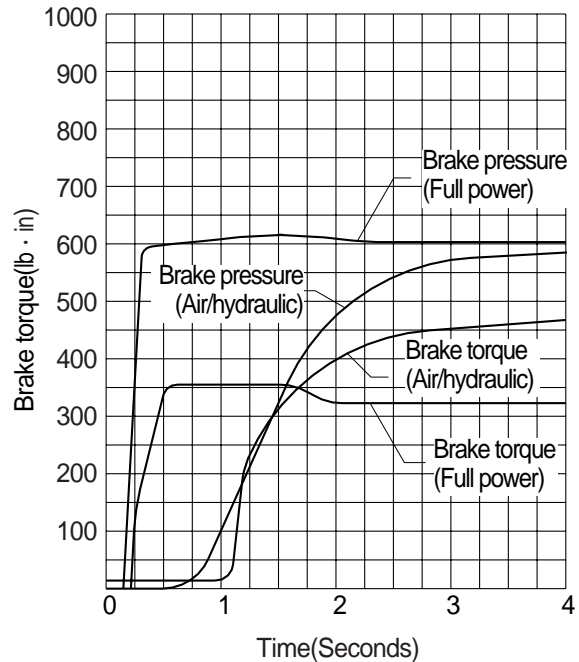

2. HYDRAULIC CIRCUIT

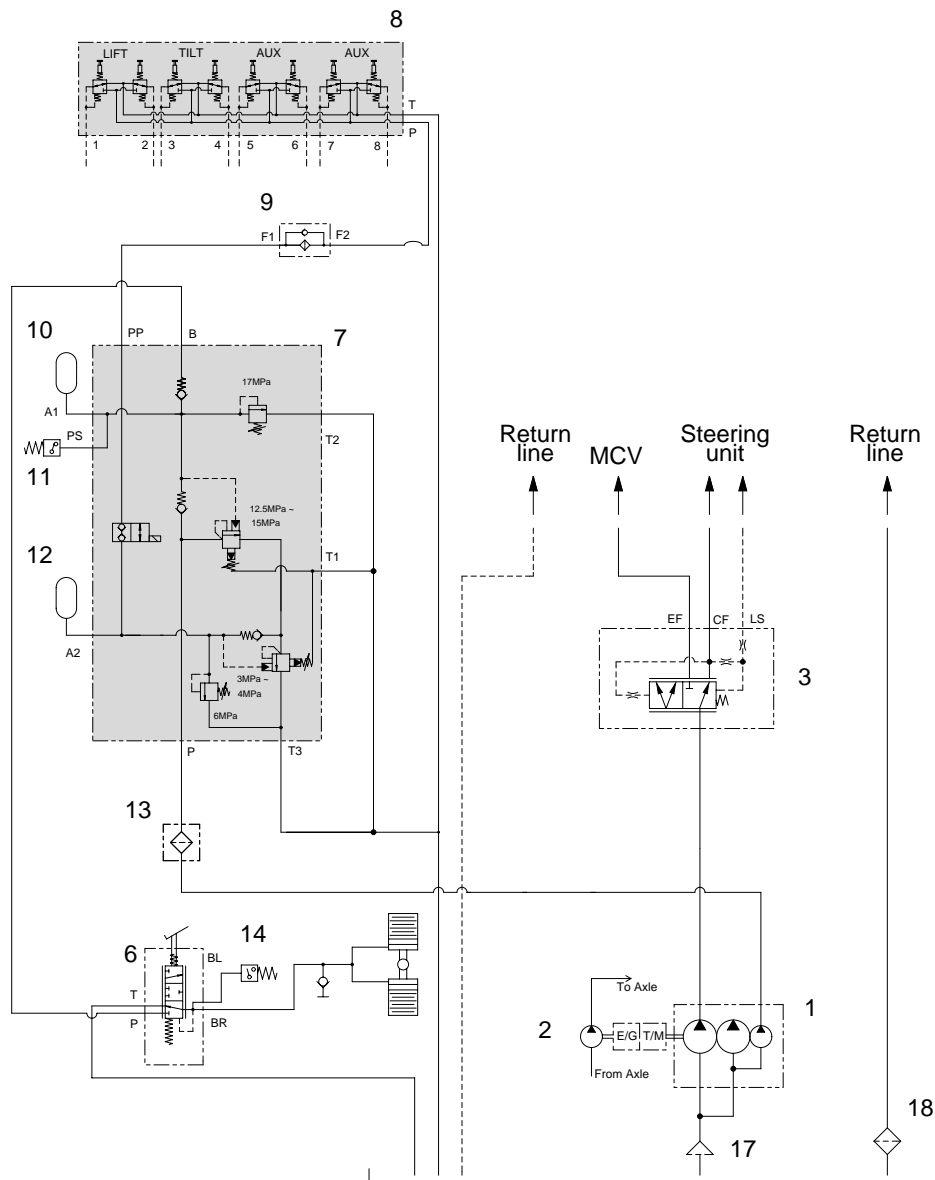

50D7EBS01

- | | | | | | |
|---|----------------|----|-----------------|----|-----------------|
| 1 | Main pump | 8 | RCV | 13 | Line filter |
| 2 | Brake pump | 9 | Line filter | 14 | Pressure switch |
| 3 | Priority valve | 10 | Accumulator | 17 | Strainer |
| 6 | Brake valve | 11 | Pressure switch | 18 | Return filter |
| 7 | Cut-off valve | 12 | Accumulator | | |

1) SERVICE BRAKE RELEASED

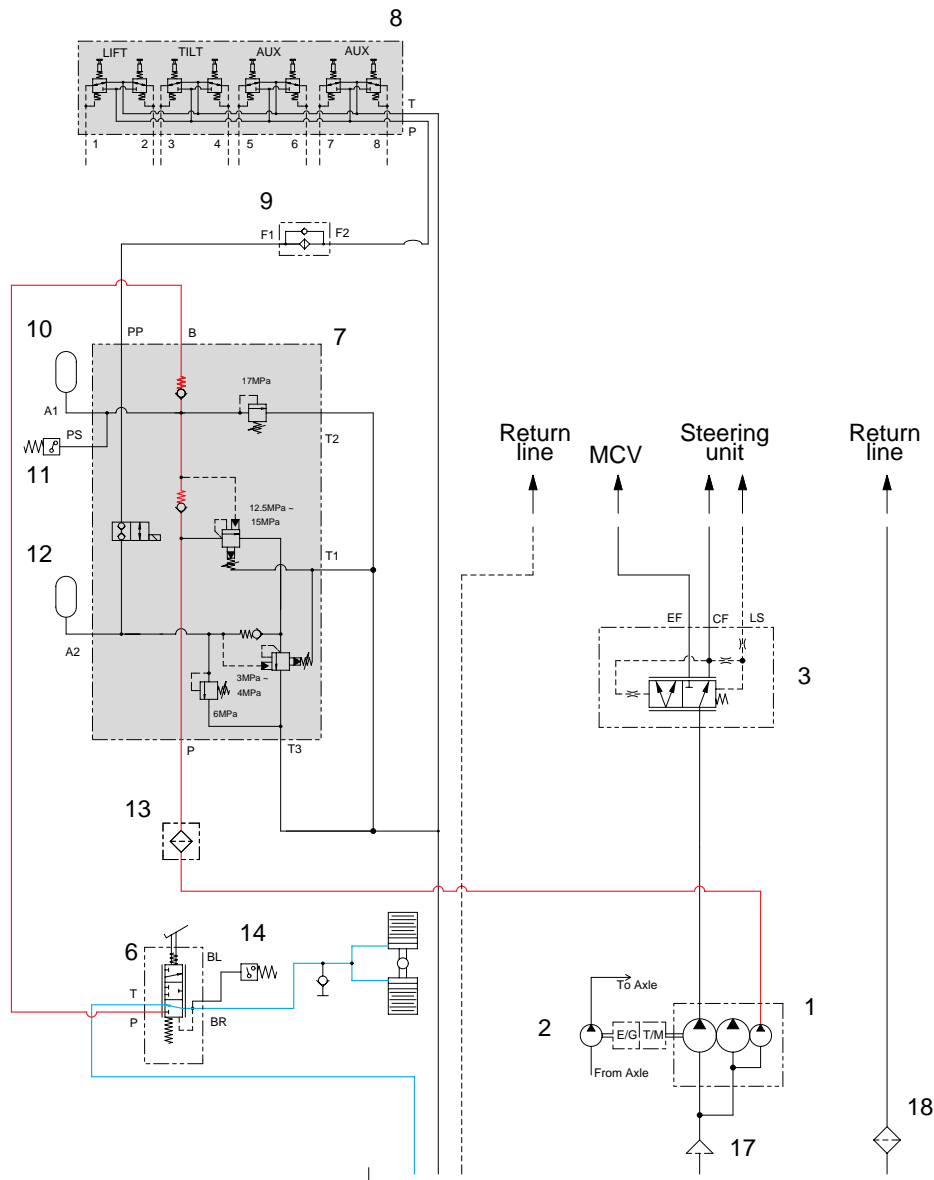

50D7EBS02

When the pedal of brake valve(6) is released, the operating force is eliminated by the force of the spring, and the spool is returned.

When the spool removes up, the drain port is opened and the hydraulic oil in the piston of axles return to the tank.

Therefore, the service brake is kept released.

2) SERVICE BRAKE OPERATED

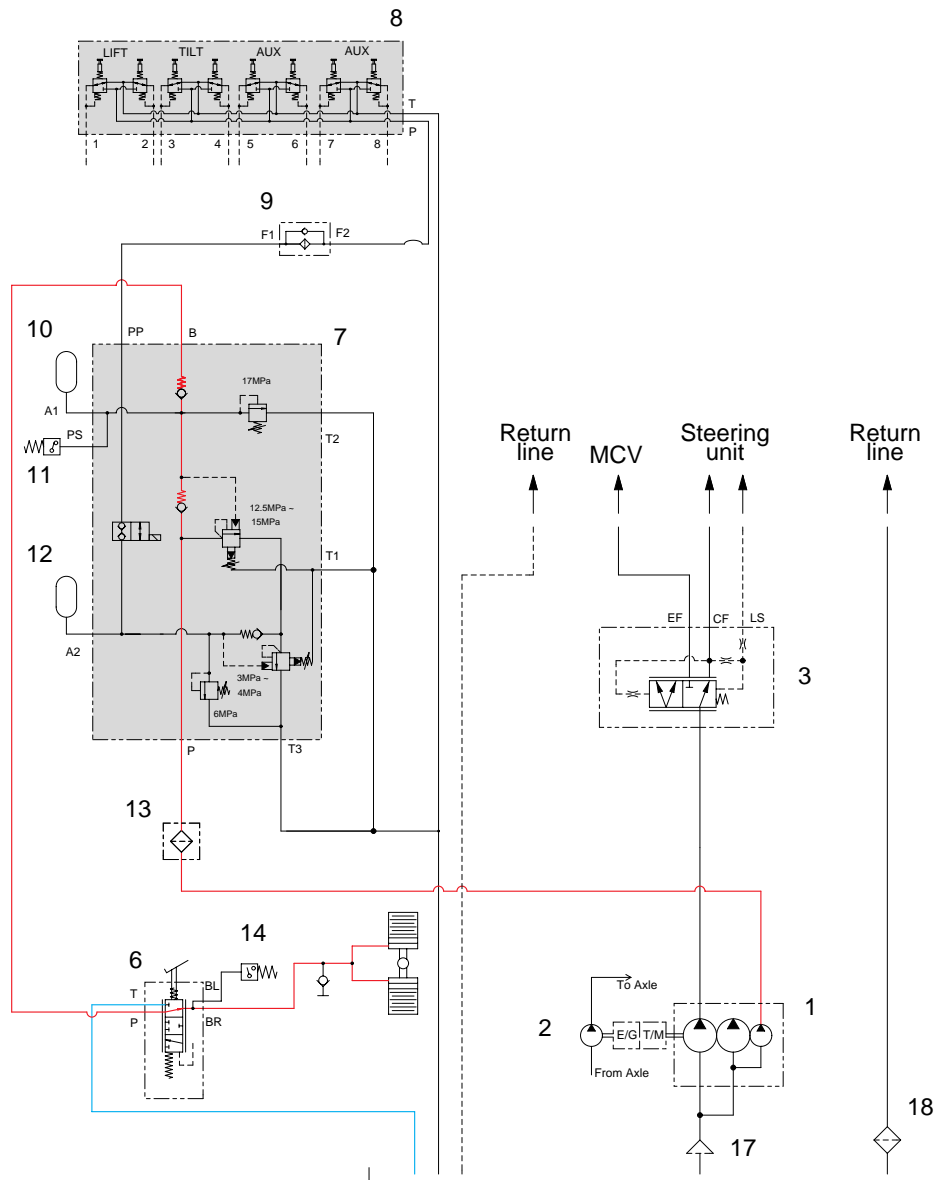

50D7EBS03

When the pedal of brake valve(6) is depressed, the operating force overcomes the force of the spring, and is transmitted to the spool. When the spool moves down, the inlet port is opened, and at the same time the hydraulic oil controlled the pressure level by the cut-off valve(7) enters the piston in the front and rear axles. Therefore, the service brake is applied.

3) DO AEB WORK

- (1) Start engine after parking the machine on flat floor and blocking wheels.
 - (2) Release parking brake.
 - (3) With stepping on the service brake, operate T/M STALL(3 stage).
(To avoid defect of clutch pack, repeat 10 sec of operation and 10 sec of placing neutral)
 - (4) When the T/M oil temperature reaches 75~80° C, lock the parking brake and then shift gear to neutral position to keep the machine at LOW RPM.
 - (5) Connect the AEB STARTER to T/M controller.
 - (6) Push AEB STARTER over 3 seconds.
 - (7) Confirm the status of AEB from the DISPLAY.
 - Normal operation shows "ST, KR, KV, KC, KD, KE" orderly for 3~5minutes.
 - After the successful completion, it displays " OK".
 - With a new controller, it may display "F6" error code before AEB, but after AEB, it will disappear.
 - (8) In case of abnormal running, it may display "STOP" with the appropriate error code.
 - (9) After troubleshooting, start the machine again to repeat above.
- ※ As the STALL operation has to be done, the SERVICE BRAKE must be locked perfectly to avoid the fatal accident.

3. INCHING PEDAL AND LINKAGE

The brake pedal serves to actuate the hydraulic brakes on the front axle. At the beginning of the pedal stroke, the inching spool of the transmission control valve is actuated to shift the hydraulic clutch to neutral and turn off the driving force. By treading the pedal further, the brake is applied.

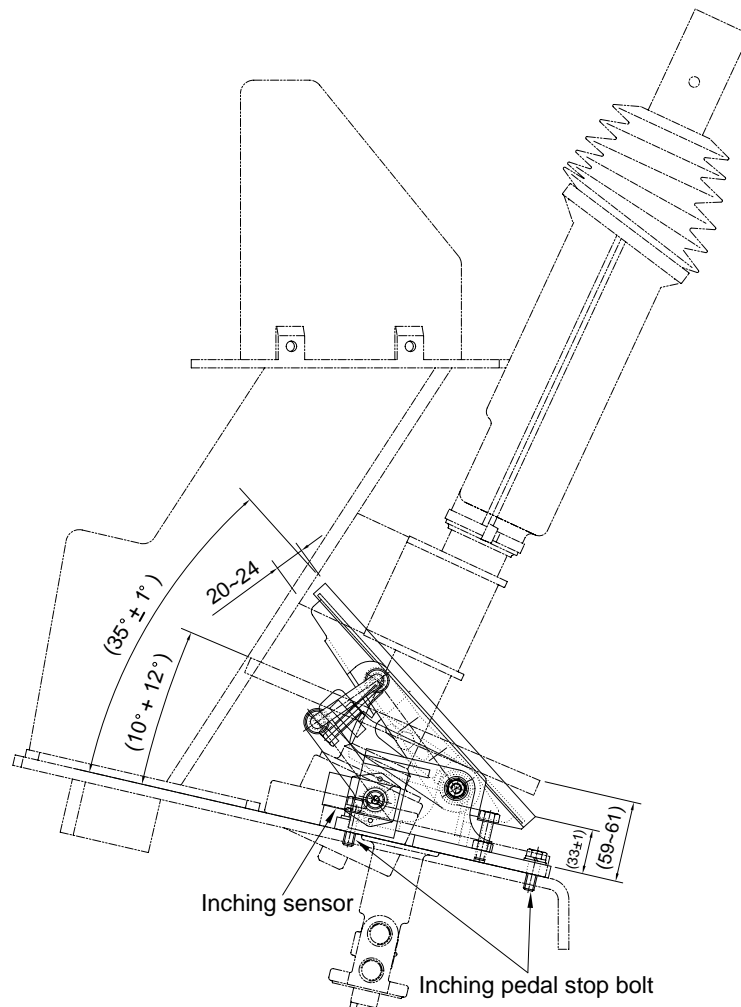

50D7EBS04

1) INITIALIZING THE INCHING SENSOR

- (1) Start engine after parking the machine on flat floor and blocking wheels.
 - (2) Release parking brake and keep neutral gear shift.
 - (3) Adjust the inching sensor linkage so that the regular voltage is supplied to inching sensor when operating the pedal.
(Regular voltage ; Before pedal operation($1 \pm 0.1V$),
After pedal operation($3.5 \pm 0.1V$))
 - (4) Stop the engine and then just KEY ON.(Release parking brake, keep neutral gear)
 - (5) Connect the AEB STARTER to the T/M controller.
 - (6) Push AEB STARTER over 3 seconds.
 - (7) If display shows "▼IP", Step on the pedal fully.
 - (8) If display shows "▲IP", release "OK"
 - (9) After the successful completion, it displays "OK".
 - (10) In case of abnormal running, it may display "STOP" with the appropriate error code.
 - (11) After troubleshooting, start the machine again to repeat above.
- ※ Above works are to be done with the parking brake released, so machine's wheels must be blocked for safety.

4. DISK BRAKE

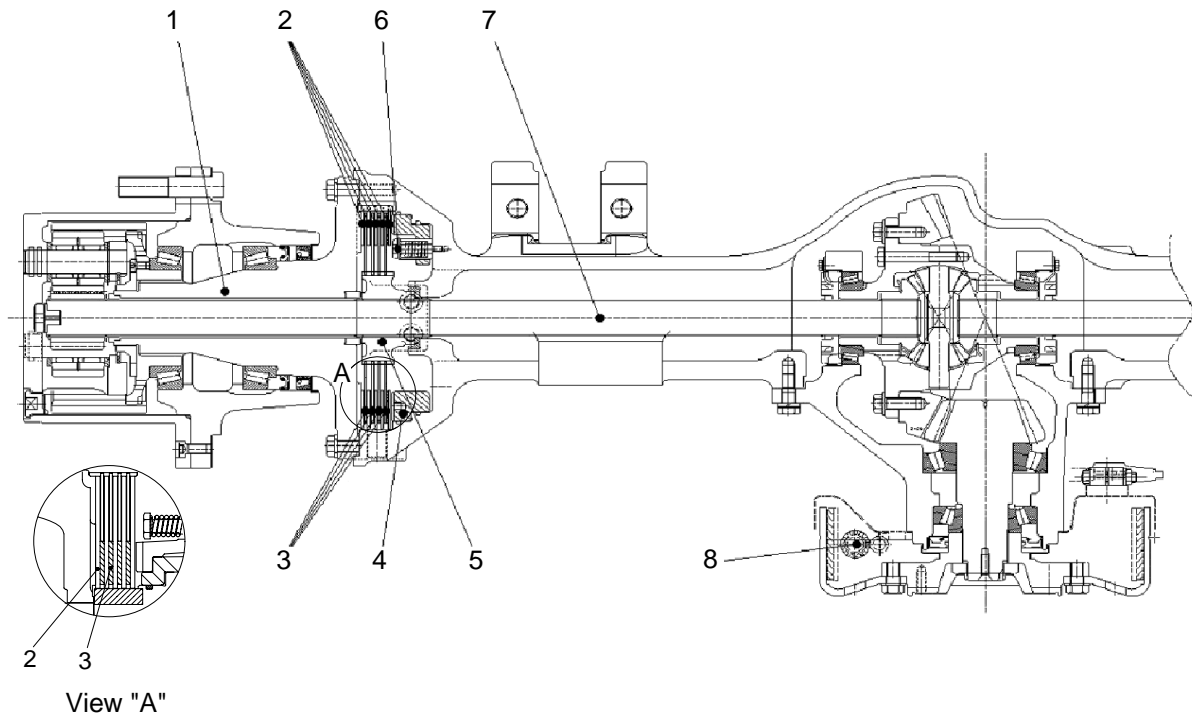

50D7EAX05

- | | | |
|---------------|------------------------------|-----------------|
| 1 Spindle | 4 Service piston | 7 Drive shaft |
| 2 Steel plate | 5 Service collar | 8 Parking brake |
| 3 Disk plate | 6 Service piston adjust bolt | |

OPERATION

Sealed up structure of hydraulic multi-disk brake system secures good brake performance even in the high humid or dusty area.

Because it is possible to use the brake semi-permanently, there is no need to maintain its lining as drum type brake do. Also with self-adjust of friction plate clearance, it's easy to prevent the brake performance drop due to friction material wear.

Major components are 4 disk plates(3), 5 steel plates(2), service piston(4) and 4 piston adjust bolts (5). Braking take places when the discs and plates are pressed each other which make rotation resistance to the collar (6) and the drive shaft (7).

5. BRAKE VALVE

1) STRUCTURE

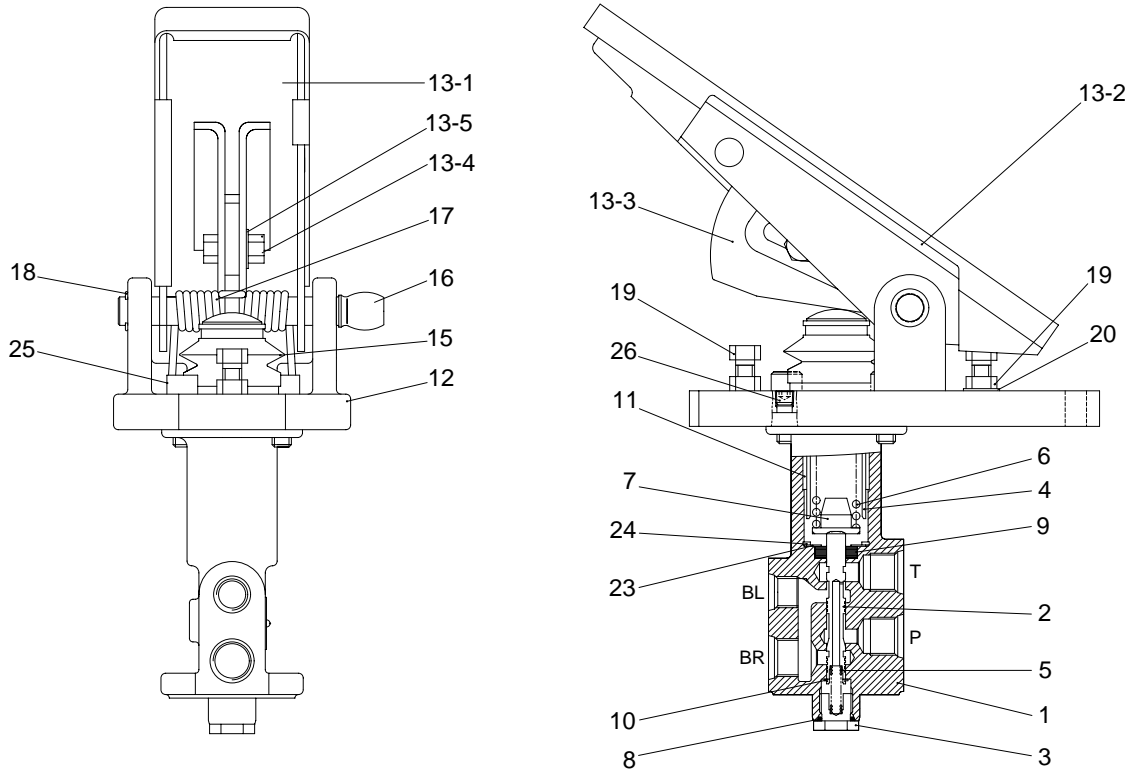

110D7EBS07

- | | | | | | |
|----|-----------------|------|----------------|----|----------------|
| 1 | Body | 11 | Du bushing | 17 | Torsion spring |
| 2 | Spool | 12 | Pedal plate | 18 | Snap ring |
| 3 | Plug | 13 | Pedal assembly | 19 | Hexagon bolt |
| 4 | Holder(piston) | 13-1 | Pedal | 20 | Hexagon nut |
| 5 | Lower spring | 13-2 | Rubber | 23 | Plain washer |
| 6 | Main spring | 13-3 | Lock plate | 24 | Snap ring |
| 7 | Spring retainer | 13-4 | Hexagon bolt | 25 | Bolt |
| 8 | O-ring | 13-5 | Plate washer | 26 | Taper plug |
| 9 | Oil seal | | | | |
| 10 | Snap ring | 15 | Bellows | | |
| | | 16 | Lock pin 1 | | |

2) OPERATION

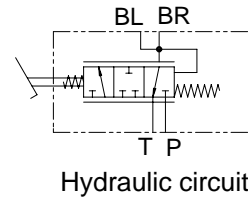
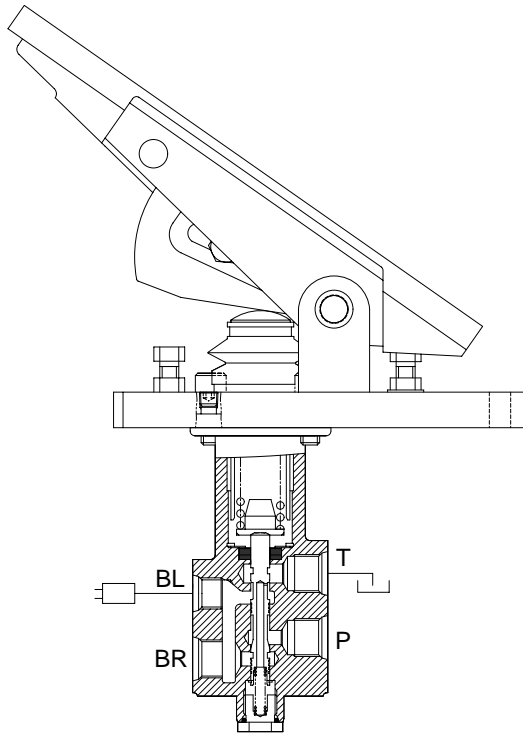

Port	Port name	Port size
P	Main pressure port	PF3/8
T	Drain port	PF3/8
BR	Brake cylinder port	PF3/8
BL	Pressure switch port	PF1/4

110D7EBS08

(1) Purpose

The purpose of the brake valve is to sensitively increase and decrease the braking pressure when the brake pedal is actuated.

(2) Ready position

A connection is established between ports(BR) and ports(T) so that the wheel brakes ports(BR) are pressureless via the returns ports(T).

(3) Partial braking

When the brake valve is actuated, an amount of hydraulic pressure is output as a ratio of the foot force applied.

The main spring(6) beneath pedal plate(12) is designed in such a way that the braking pressure changes depending on the angle. In the lower braking pressure range, the machine can be slowed sensitively.

When the braking process is commenced, the spool(2) is mechanically actuated via main spring (6). As spool(2) move downward, they will first close returns(T) via the control edges, thus establishing a connection between accumulator ports(P) and ports(BR) for the wheel brake cylinders. The foot force applied now determines the output braking pressure. The control spool(2) is held in the control position by the force applied(Spring assembly above the spool).

After output of the braking pressure, spool(2) is in a partial braking position, causing ports(P) and ports(T) to close and holding the pressure in ports(BR).

(4) Full braking position

When pedal is fully actuated, end position of the brakes is reached and a connection established between accumulator ports(P) and brake cylinder ports(BR). Returns(T) are closed at this point.

When the braking process is ended, a connection is once again established between brake cylinder ports(BR) and return ports(T), closing accumulator ports(P).

(5) Limiting the braking pressure

Pedal restriction bolt(19) on base plate below pedal is used to limit the braking pressure.

(6) Installation requirements

Return lines(T) must be connected directly to the tank.

The connecting lines must be installed in such a way as to permit proper bleeding.

(7) Maintenance of the brake valve

No special maintenance beyond the legal requirements is necessary.

When using high-pressure cleaners on the machine, please make sure that the water jet is not aimed directly at the brake valve(To prevent damaging the bellows).

△ **For safety reasons the whole of the brake valve must be replaced if parts other than those listed above are damaged.**

(8) Repair work

- △ When working on the braking system, always make sure that there is absolutely no pressure in the system. Even when the engine is switched off there will be some residual pressure in the system.
- ※ When doing repair work, make sure your environment is very clean.
Immediately close all open ports on the components and on pipes using plugs.

(9) Replacing the pedal cover

Pedal cover(13-2) is simply pulled off by hand. The new pedal cover is pushed over pedal(13-1) and tightened manually. Fasten the bellows with the strap retainers.

(10) Replacing the complete actuating mechanism

Carefully clamp the unit vertically in a fixture. The actuating mechanism can be removed by taking out the four bolts. Make sure that main spring (6) does not fall out. When installing the new actuating mechanism, make sure that main spring (6) is fitted in the right order.

(11) Replacing the bellows

To change bellows(15) it is advisable to remove pedal(13). For this purpose, loosen retaining ring (18) and knock out pin 1(16) using a mandrill. When knocking out the bolt, make sure that the mandrill is applied to the side of the bolt without a knurl. Remove pedal(13) and bellows(15).

Now fit the new bellows and proceed in reverse order as described above. The upper portion of bellows is fastened to piston(4), its lower portion to pedal plate(12) secure the bellows using clamps.

6. CUT-OFF VALVE

1) STRUCTURE

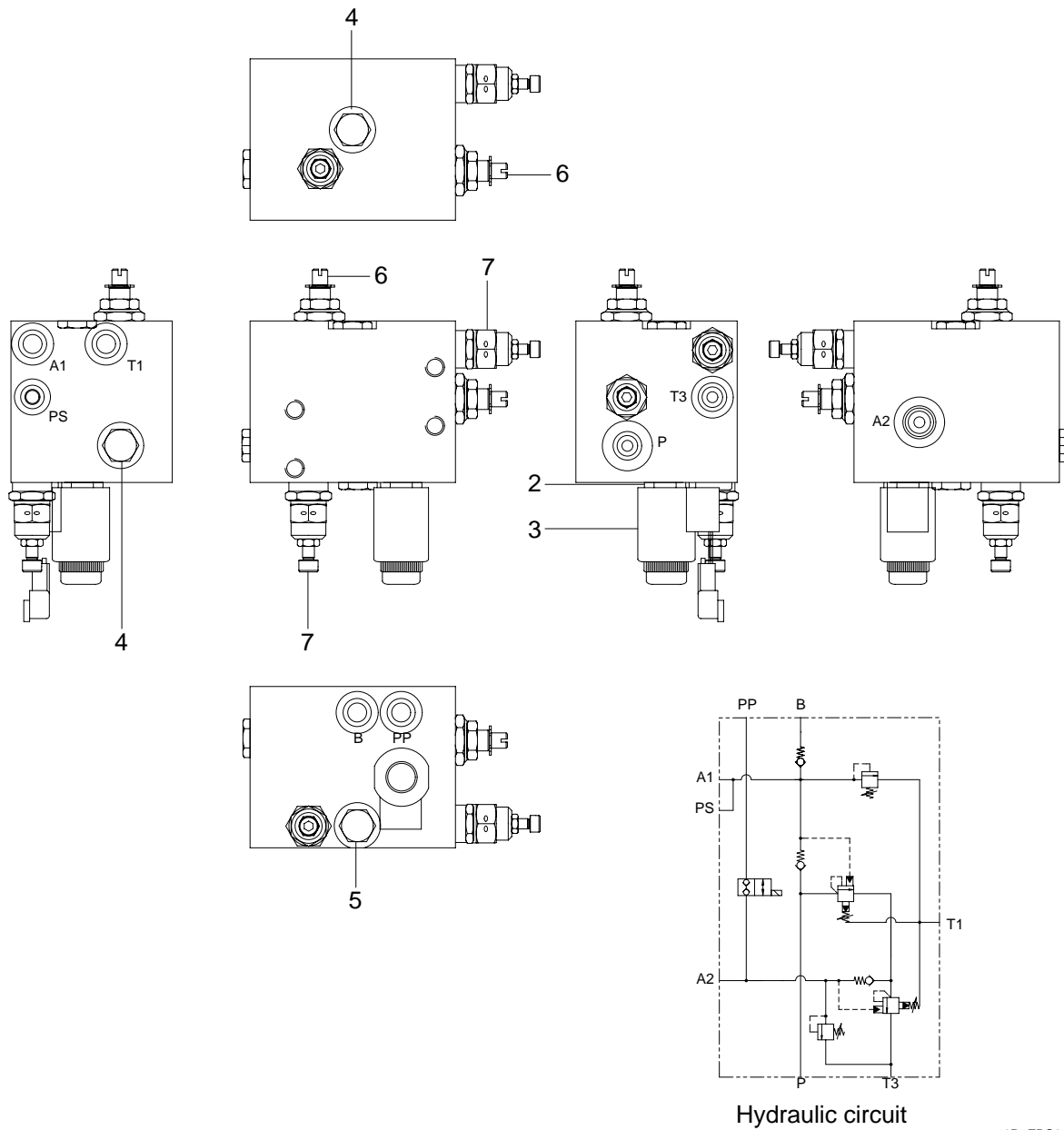

- | | | | |
|---|----------------|---|---------------|
| 1 | Manifold | 5 | Check valve |
| 2 | Solenoid valve | 6 | Cut-off valve |
| 3 | Coil | 7 | Relief valve |
| 4 | Check valve | | |

2) OPERATION

When the pump works, the oil under the pressure flows into P port.

The oil in P port is stored in the accumulator on A3 port.

As the pressure on P line rises to 150bar, the cut off valve(1) starts cut-offting and the oil in the P port is unloaded. The pressure on P line goes down 120bar by the minute leakage from valve and other factors.

At this pressure, the cut-off valve starts cutting.

This process is repeated in the regular period of 30~40 seconds.

50D7EBS35-1

7. BRAKE ACCUMULATOR

1) STRUCTURE

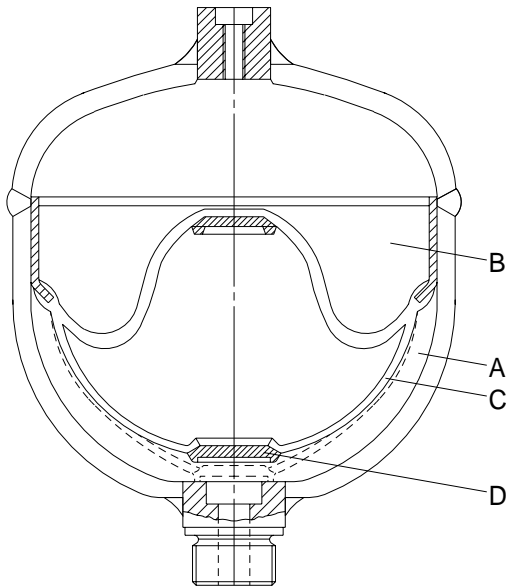

Item	81L1-0004
Diameter	110mm
Mounting height	164mm
Nominal volume	0.7 l
Priming pressure	50kgf/cm ²
Operating medium	Oil
Operating pressure	Max 150kgf/cm ²
Thread	M18×1.5
Priming gas	Nitrogen

A Fluid portion C Diaphragm
B Gas portion D Valve disk

(770-3ATM) 4-22

2) OPERATION

(1) Purpose

Fluids are practically incompressible and are thus incapable of accumulating pressure energy. In hydropneumatic accumulators, the compressibility of a gas is utilized to accumulate fluid. The compressible medium used in the accumulators is nitrogen.

In braking systems, the purpose of the accumulators is to store the energy supplied by the hydraulic pump. They are also used as an energy reserve when the pump is not working, as a compensator for any losses through leakage, and as oscillation dampers.

(2) Operation

The accumulator consists of a fluid portion (A) and a gas portion (B) with a diaphragm (C) as a gas-tight dividing element. The fluid portion (A) is connected to the hydraulic circuit, causing the diaphragm accumulator to be filled and the gas volume to be compressed as the pressure rises.

When the pressure falls, the compressed gas volume will expand, thus displacing the accumulated pressure fluid into the circuit.

The diaphragm bottom contains a valve disk (D) which, if the diaphragm accumulator is completely empty, closes the hydraulic outlet, thus preventing damage to the diaphragm.

(3) Installation requirements

The accumulators can be fitted in the hydraulic circuit, directly on a component or in blocks on suitable consoles.

They should be fitted in as cool a location as possible.

Installation can be in any position.

(4) Maintenance of the accumulator

No special maintenance beyond the legal requirements is necessary.

The accumulator should be checked annually. It should be replaced if the initial gas pressure has fallen by more than 30% (Please refer to **Performance testing and checking of the accumulator**).

(5) Disposal of the accumulator

Before the accumulator is scrapped, its gas filling pressure must be reduced. For this purpose, drill a hole through gas chamber (B) using a drill approx. 3mm in diameter. The gas chamber is located on the side opposite the threaded port above the welding seam around the center of the accumulator.

※ Wear safety goggles when doing this job.

(6) Performance testing and checking of the accumulator

The accumulator is gradually pressurized via the test pump; until the initial gas pressure is reached, the hydraulic pressure in the accumulator will rise abruptly. This is apparent from gauge **M**. If the initial gas pressure is more than 30% below the prescribed value, the accumulator needs to be replaced. If the measuring process needs to be repeated, wait for intervals of 3 minutes between the individual tests. Any accumulator whose initial gas pressure is insufficient must be scrapped following the instructions under **Disposal of the accumulator**.

The amount of initial gas pressure can also be checked from the vehicle. Start the vehicle's engine. The pump will now supply oil to the accumulators. Until the initial gas pressure is reached, the hydraulic pressure in the accumulator will rise abruptly. This is apparent from the gauge in the cab. If the initial gas pressure is more than 30% below the prescribed value, that initial pressure lies outside the permissible range for **at least one** of the accumulators fitted in the vehicle. This accumulator can be traced only by using the method described above, i.e. all accumulators have to be individually tested. The accumulator whose initial gas pressure is insufficient must be replaced and scrapped following the instruction under **Disposal of the accumulator**.

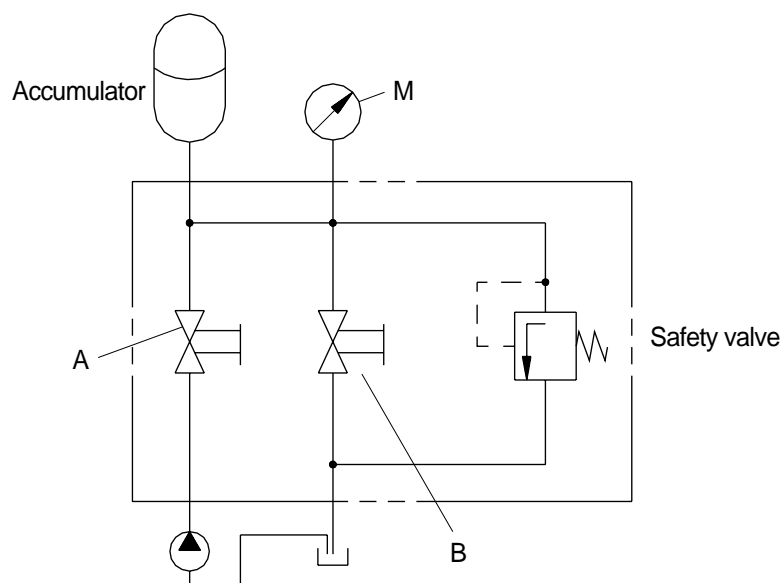

(770-3ATM) 4-23

(7) Repair work

- △ **When working on the braking system, always make sure that there is absolutely no pressure in the system. Even when the engine is switched off there will be some residual pressure in the system.**
- ※ **When doing repair work, make sure your environment is very clean.
Immediately close all open ports on the components and on pipes using plugs.**
- △ **For safety reasons the accumulators need to be replaced as a whole if damaged.**

8. PRESSURE SWITCHES

1) STRUCTURE

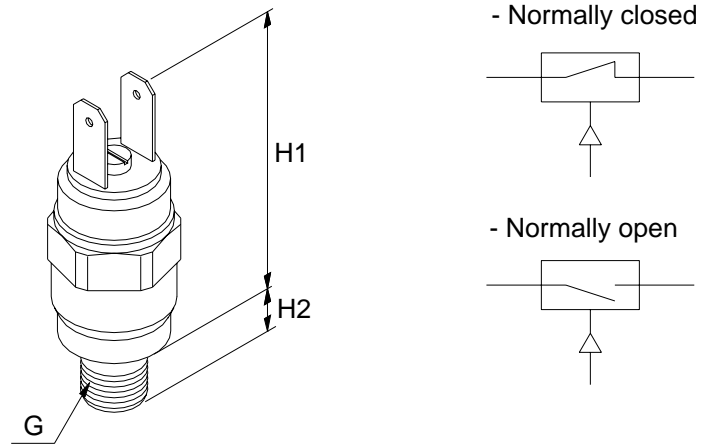

7407ABS20

• Technical data

Item	Type	Medium	G	H1 mm	H2 mm	Adjusting range kgf/cm ²	Adjusting pressure kgf/cm ²	Voltage V
Parking	NC	Oil	M12 × 1.5	46	9	50 ~ 150	95 ± 5	Max 42
Charging	NC	Oil	M12 × 1.5	46	9	50 ~ 150	95 ± 5	Max 42
Brake stop	NO	Oil	M12 × 1.5	46	9	1~10	5 ± 1	Max 42

NC : Normally closed

NO : Normally open

2) OPERATION

(1) Purpose

The pressure switches are used to visually or audibly warn the driver of the pressure within the system.

(2) Make contact / circuit closer

The pressure switch can be fitted in the braking system or directly on one of its components.

The system pressure acts on an absorption area within the switch, making an electrical contact as the pressure on that area is increased. The resulting current is used to activate a warning facility, for instance.

(3) Break contact / circuit breaker

The pressure switch can be fitted in the braking system or directly on one of its components.

The system pressure acts on a absorption area within the switch, breaking an electrical contact as the pressure on that area is increased. The current is now broken, e.g. to deactivate a warning facility.

(4) Installation requirements

No special measures need to be taken.

(5) Maintenance of the pressure switch

No special maintenance beyond the legal requirements is necessary.

When using high-pressure cleaners on the vehicle, please make sure that the water jet is not directed at the pressure switch (Corrosion of contacts).

(6) Repair work

△ **When working on the braking system, always make sure that there is absolutely no pressure in the system. Even when the engine is switched off there will be some residual pressure in the system.**

※ When doing repair work, make sure your environment is very clean.

Immediately close all open ports on the components and on pipes using plugs.

※ For safety reasons the pressure switch needs to be replaced as a whole if damaged.

(7) Adjusting and testing pressure switch

The adjusting screw located between the two contact plugs can be set to the desired value within a certain range. For adjusting range, please refer to the table **Technical data** on the previous page.

After making the adjustment, the adjusting screw should be secured using wax or a similar material.

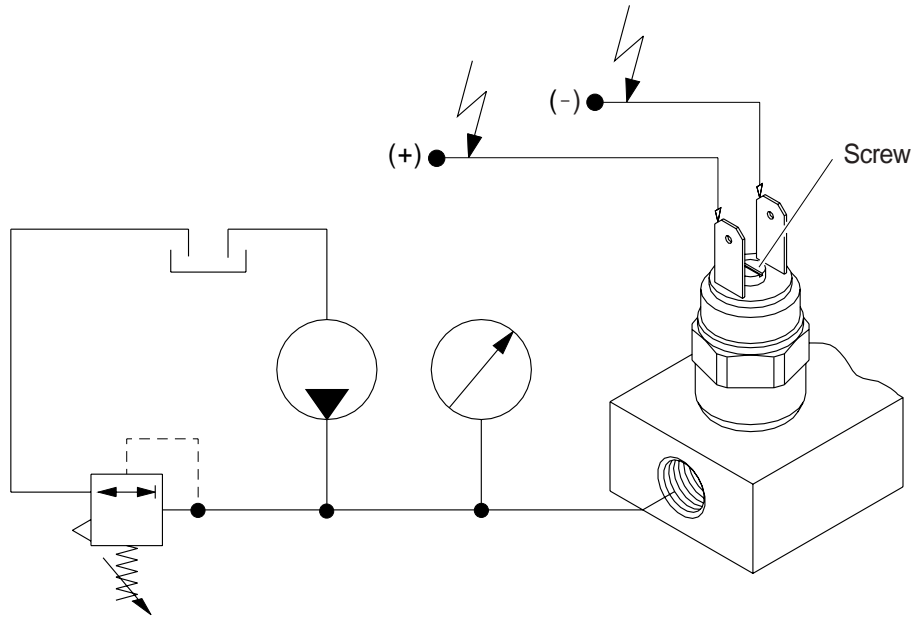

(770-3ATM) 4-25

GROUP 2 OPERATIONAL CHECKS AND TROUBLESHOOTING

1. OPERATIONAL CHECKS

1) BRAKE PIPING

- (1) Check pipes, hoses and joints for damage, oil leakage or interference.
- (2) Operate brake pedal and check operating force when pedal is depressed. Check also change in operating force, and change in position of pedal when pedal is kept depressed.

2) PARKING BRAKE

- (1) Operating force of parking lever is 35 - 40 kgf · m (253 - 290 lbf · ft).
- (2) Check that parking brake can hold machine in position when loaded on 20% slope. If there is no slope available, travel at low speed and check braking effect of parking brake.

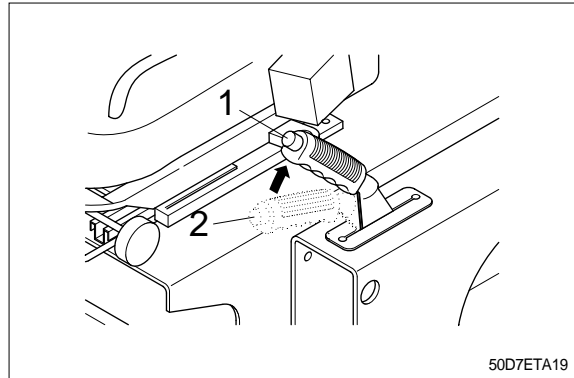

2. TROUBLESHOOTING

Problem	cause	Remedy
Insufficient braking force	<ul style="list-style-type: none"> • Hydraulic system leaks oil. • Hydraulic system leaks air. • Disk worn. • Brake valve malfunctioning. • Hydraulic system clogged. 	<ul style="list-style-type: none"> • Repair and add oil. • Bleed air. • Replace. • Repair or replace. • Clean.
Brake acting unevenly. (Machine is turned to one side during braking.)	<ul style="list-style-type: none"> • Tires unequally inflated. • Brake out of adjustment. • Disk surface roughened. • Wheel bearing out of adjustment. • Hydraulic system clogged. 	<ul style="list-style-type: none"> • Adjust tire pressure. • Adjust. • Repair by polishing or replace. • Adjust or replace. • Clean.
Brake trailing.	<ul style="list-style-type: none"> • Pedal has no play. • Piston cup faulty. • Brake valve return port clogged. • Hydraulic system clogged. • Wheel bearing out of adjustment. 	<ul style="list-style-type: none"> • Adjust. • Replace. • Clean. • Clean. • Adjust or replace.
Brake chirps	<ul style="list-style-type: none"> • Brake trailing. • Piston fails to return. • Disk worn. • Disk surface roughened. 	<ul style="list-style-type: none"> • See above. Brake trailing. • Replace. • Replace. • Repair by polishing or replace.
Brake squeaks	<ul style="list-style-type: none"> • Disk surface roughened. • Disk worn. • Excessively large friction between disk plate. 	<ul style="list-style-type: none"> • Repair by polishing or replace. • Replace. • Clean and apply brake grease.
Large pedal stroke	<ul style="list-style-type: none"> • Brake out of adjustment. • Hydraulic line sucking air. • Oil leaks from hydraulic line, or lack of oil. • Disk worn. 	<ul style="list-style-type: none"> • Adjust. • Bleed air. • Check and repair or add oil. • Replace.
Pedal dragging.	<ul style="list-style-type: none"> • Twisted push rod caused by improperly fitted brake valve. • Brake valve seal faulty. 	<ul style="list-style-type: none"> • Adjust. • Replace.

GROUP 3 TESTS AND ADJUSTMENTS

- 1) Air bleeding should be performed by two persons :
One rides on truck for depressing and releasing brake pedal : the other person is on the ground and removes cap from air vent plug on wheel cylinder.
- 2) Block the front wheel securely and apply parking brake.
- 3) Start the engine.
- 4) Attach a vinyl tube to air vent plug and immerse other end of tube into a vessel filled with hydraulic oil.
- 5) Loosen air vent plug by turning it 3/4 with a wrench. Depress brake pedal to drain oil mixed with air bubbles from plug hole.
- 6) Depress brake pedal until no air bubbles come out of air vent plug hole.
- 7) After completion of air bleeding, securely tighten air vent plug. Install cap on plug.
- 8) Same way for the opposite side.

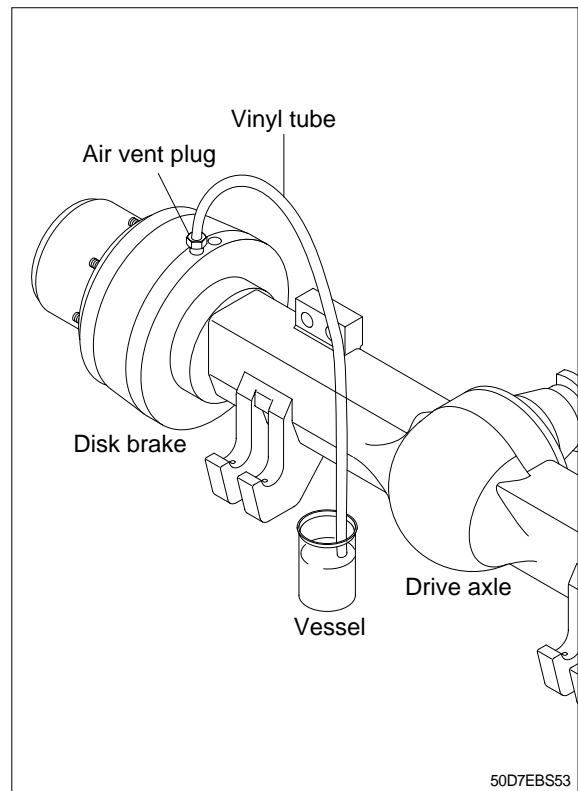

3. ADJUSTMENT OF PEDAL

1) BRAKE PEDAL

(1) Micro switch for parking brake(if equipped)

- ① After assembling parking brake and parking cable, put the parking brake lever released.
- ② Loosen the nut for parking brake plate to play up and down.
- ③ Move up the plate so that the stopper can be contacted with the pin and then reassemble nut.
 - Micro switch stroke when parking brake is applied : 2~3mm(0.08 ~ 0.1in)

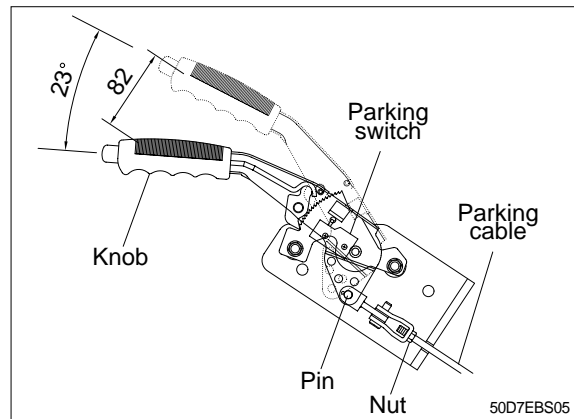

2) INCHING PEDAL

- (1) The angle stroke of the inching pedal :
23~25°
- (2) The adjusting dimension of the adjusting stopper bolt should be set with 12mm.

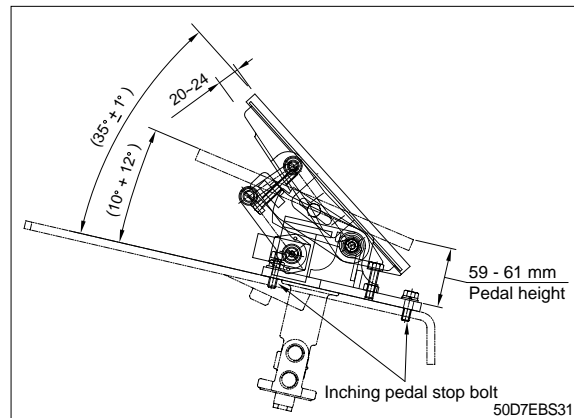

GROUP 4 DISASSEMBLY AND ASSEMBLY

1. BRAKE VALVE

1) STRUCTURE

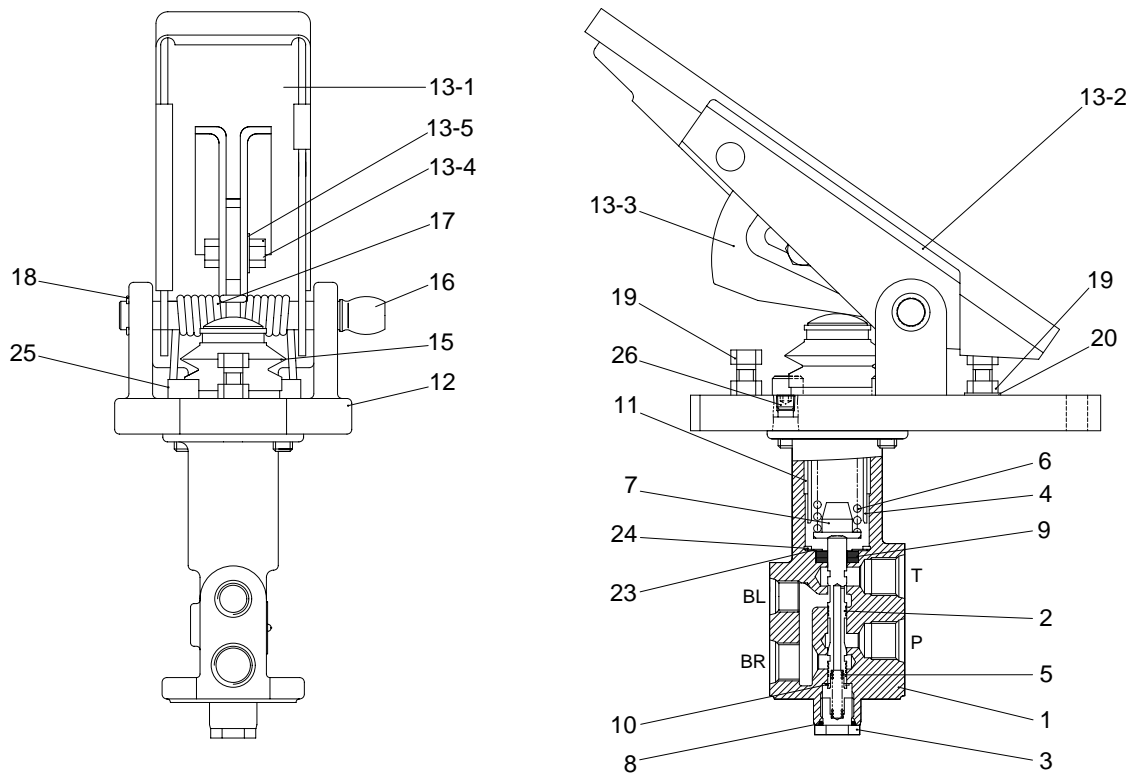

110D7EBS07

1	Body	11	Du bushing	17	Torsion spring
2	Spool	12	Pedal plate	18	Snap ring
3	Plug	13	Pedal assembly	19	Hexagon bolt
4	Holder(piston)	13-1	Pedal	20	Hexagon nut
5	Lower spring	13-2	Rubber	23	Plain washer
6	Main spring	13-3	Lock plate	24	Snap ring
7	Spring retainer	13-4	Hexagon bolt	25	Bolt
8	O-ring	13-5	Plate washer	26	Taper plug
9	Oil seal	15	Bellows		
10	Snap ring	16	Lock pin 1		

2) REASSEMBLY

(1) Body assembly

- 1 Body
- 2 Spool
- 3 Plug
- 4 Holder
- 5 Spring
- 6 Main spring
- 7 Spring retainer
- 9 Oil seal
- 11 DU bushing
- 15 Rubber cover
- 23 Plain washer
- 24 Stop ring

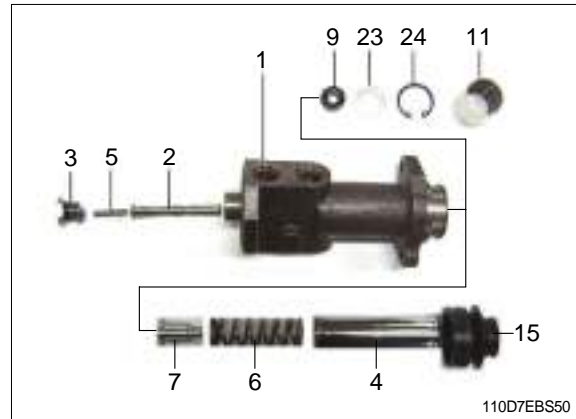

- ① Install oil seal(9), plain washer(23), stop ring(24), DU bushing(11).
- Tool : Jig for dry bearing, snap ring plier.



- ② Install spool(2) into body(1).



- ③ Tighten plug(3)
- Tool : 19mm spanner
- Tightening torque : 14.0~16.5kgf · m

▲ Press-in the DU bushing(11) with a exclusive jig.

▲ Be careful of dust and scrap after washing the parts.



- ④ Spring retainer(7), main spring(6) and holder(4).



- ⑤ Holder(4)→Body(1)

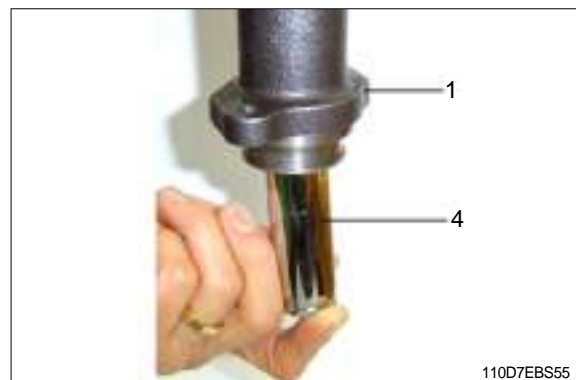

- ⑥ Rubber cover(15)



(2) Pedal plate assembly

- 12 Pedal plate
- 13-1 Pedal
- 13-2 Pedal cover
- 13-3 Lock plate
- 16 Lock pin(pedal)
- 17 Torsion spring
- 18 Stop ring
- 19 Hexagon bolt

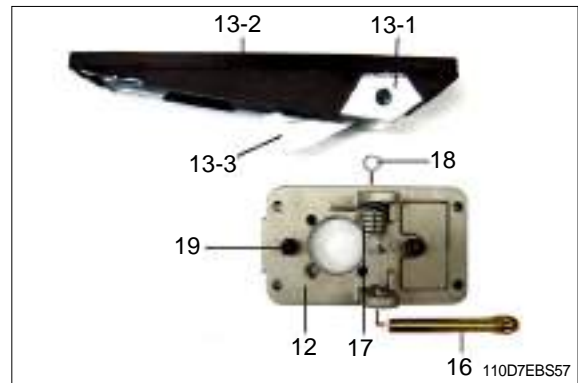

① Pedal plate(12) assembly

- Tool : 6mm torque wrench
- Tightening torque : 2.5~3.0kgf · m



② Pre-assemble pedal assembly(13-1, 13-3) and torsion spring(17) on the pedal plate(12) with a bar of $\varnothing 12$ and then push the bar with a plastic hammer.

- Tool : $\varnothing 12$ bar, plastic hammer.

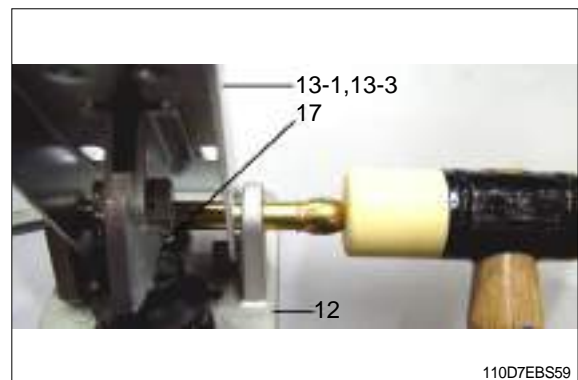

③ Lock pin(pedal)(16), stop ring(18).

- Tool : Snap ring plier for axis.

▲ To prevent pedal plate from being damaged stop ring(18) must be removed before removing lock pin(16).

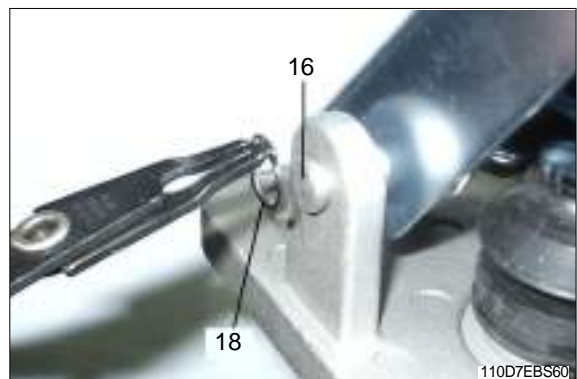

④ Rubber cover(13-2)



⑤ Hexagon bolt(19)

- Tool : 13mm spanner
- Tightening torque : 2.0kgf · m



▲ Never remove the hexagon bolt.
(Pressure setting valve deviation occurs)

SECTION 5 STEERING SYSTEM

GROUP 1 STRUCTURE AND FUNCTION

1. OUTLINE

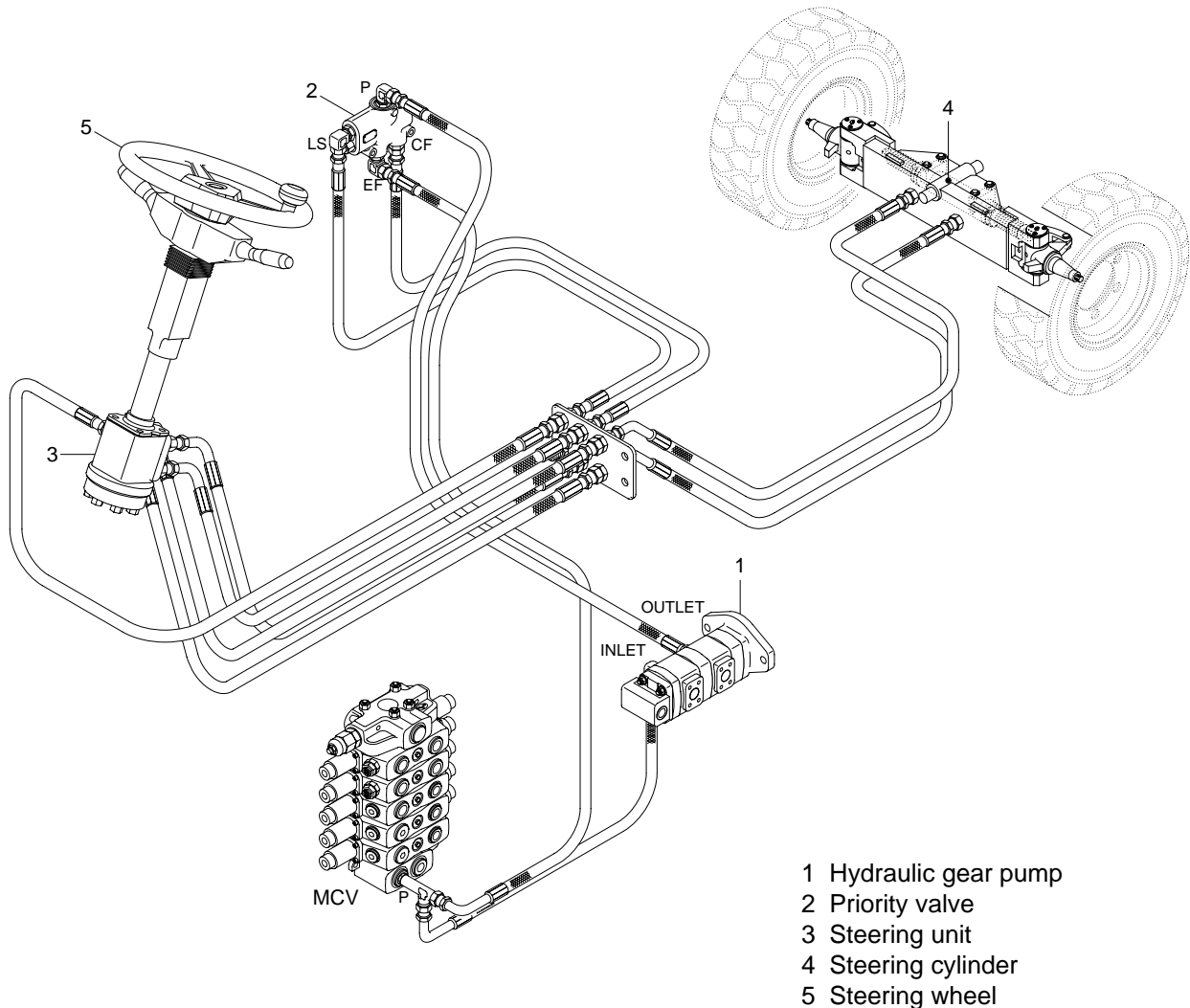

- 1 Hydraulic gear pump
- 2 Priority valve
- 3 Steering unit
- 4 Steering cylinder
- 5 Steering wheel

50D7ESE00

The steering system for this machine is composed of steering wheel assembly, steering unit, steering cylinder, trail axle and piping. The steering force given to the steering wheel enters the steering unit through the steering column. The required oil flow is sensed by the function of the control section of the unit, and pressurized oil delivered from the hydraulic pump is fed to the steering cylinder. The force produced by the steering cylinder moves the knuckle of steering tires through the intermediate link. The axle body is unit structure having steering knuckles installed to its both ends by means of kingpins. Hub and wheel are mounted through bearing to spindle of knuckle.

2. HYDRAULIC CIRCUIT

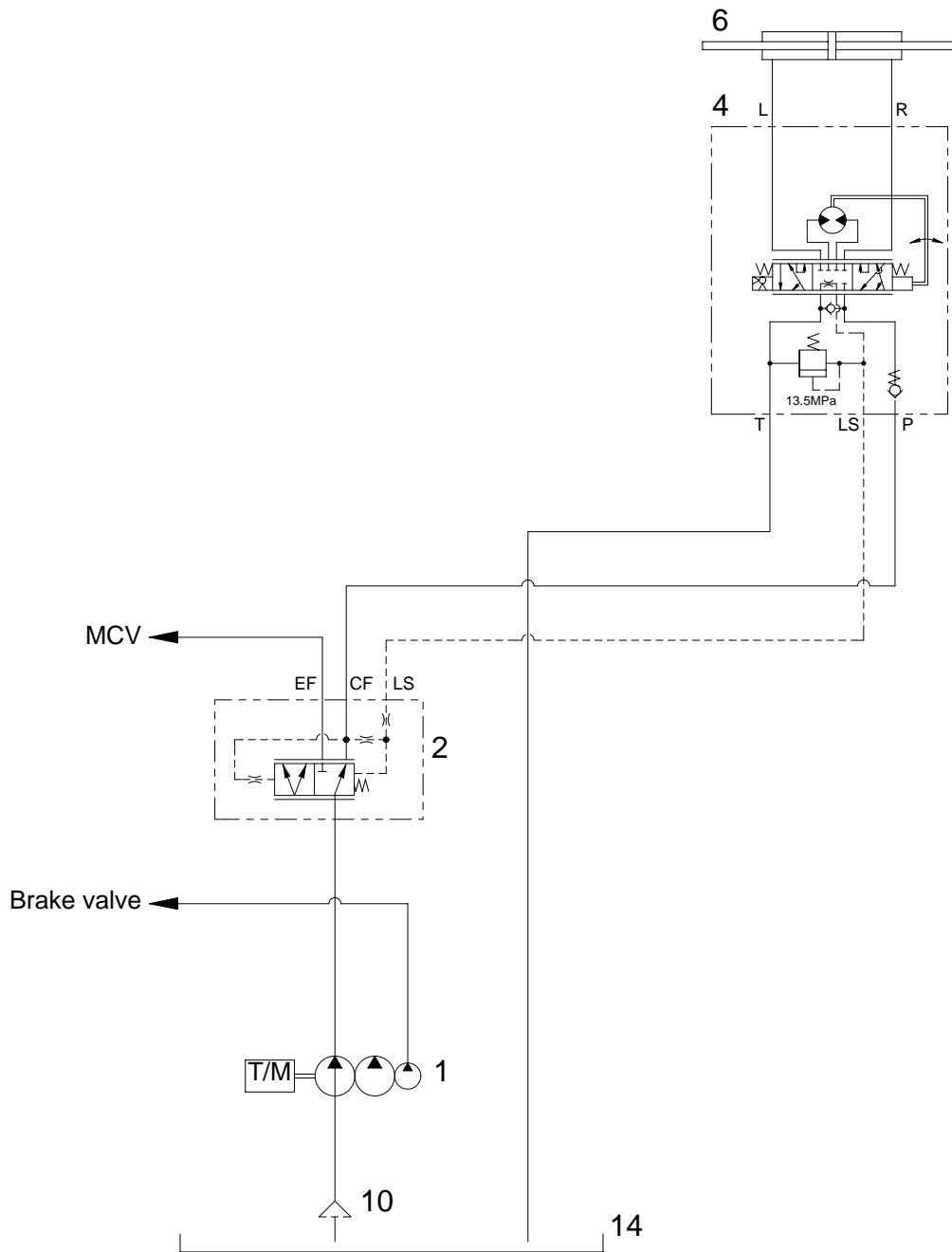

50D7ESE01

- | | | | |
|---|---------------------|----|-------------------|
| 1 | Hydraulic gear pump | 6 | Steering cylinder |
| 2 | Priority valve | 10 | Suction filter |
| 4 | Steering unit | 14 | Hydraulic tank |

1) NEUTRAL

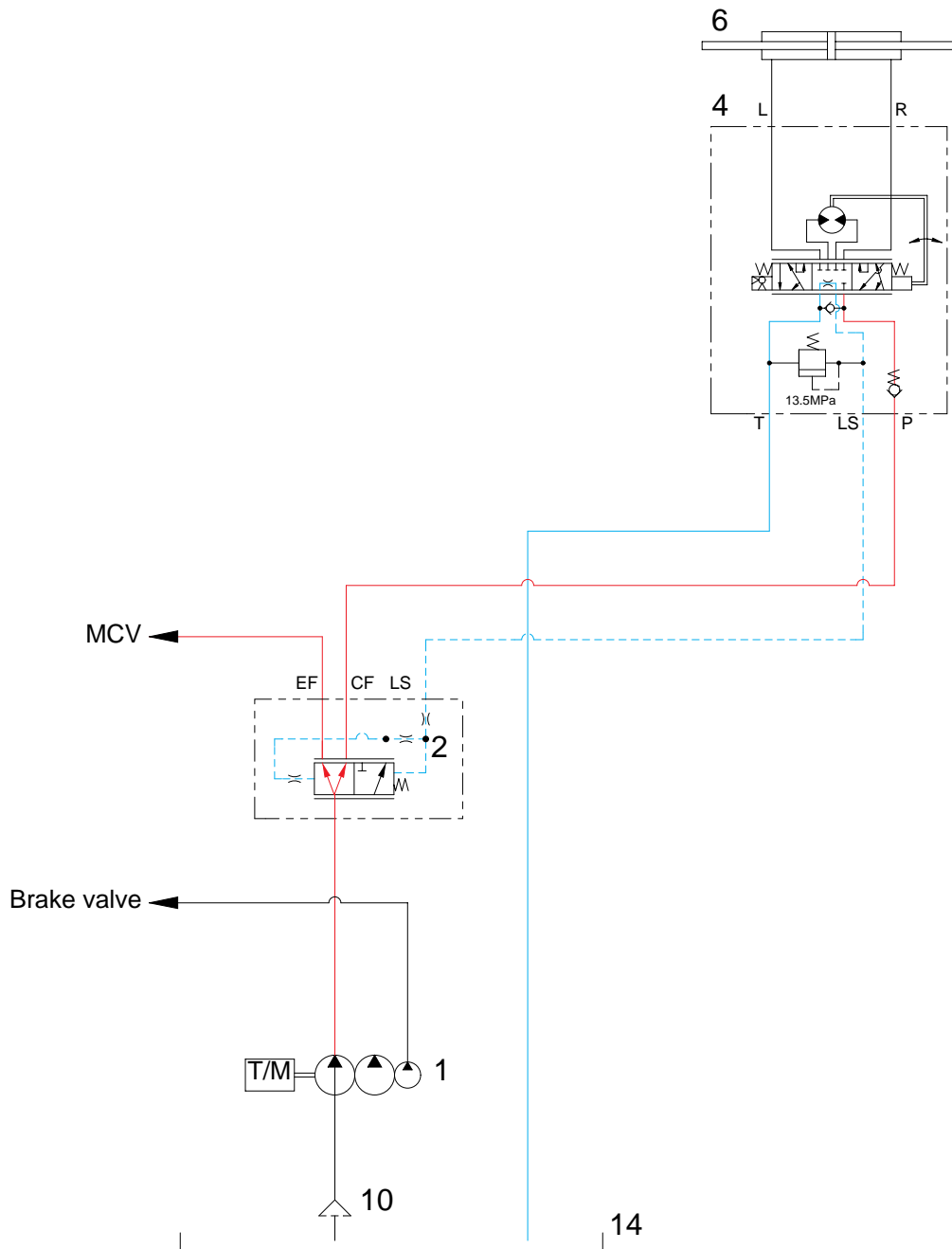

50D7ESE02

The steering wheel is not being operated, so control spool(G) does not move.

The oil from hydraulic gear pump(1) enters the port P of priority valve(3) and the inlet pressure oil moves the spool(D) to the left.

Oil flow into LS port to the hydraulic tank(14), so the pump flow is routed to the main control valve through the EF port.

2) LEFT TURN

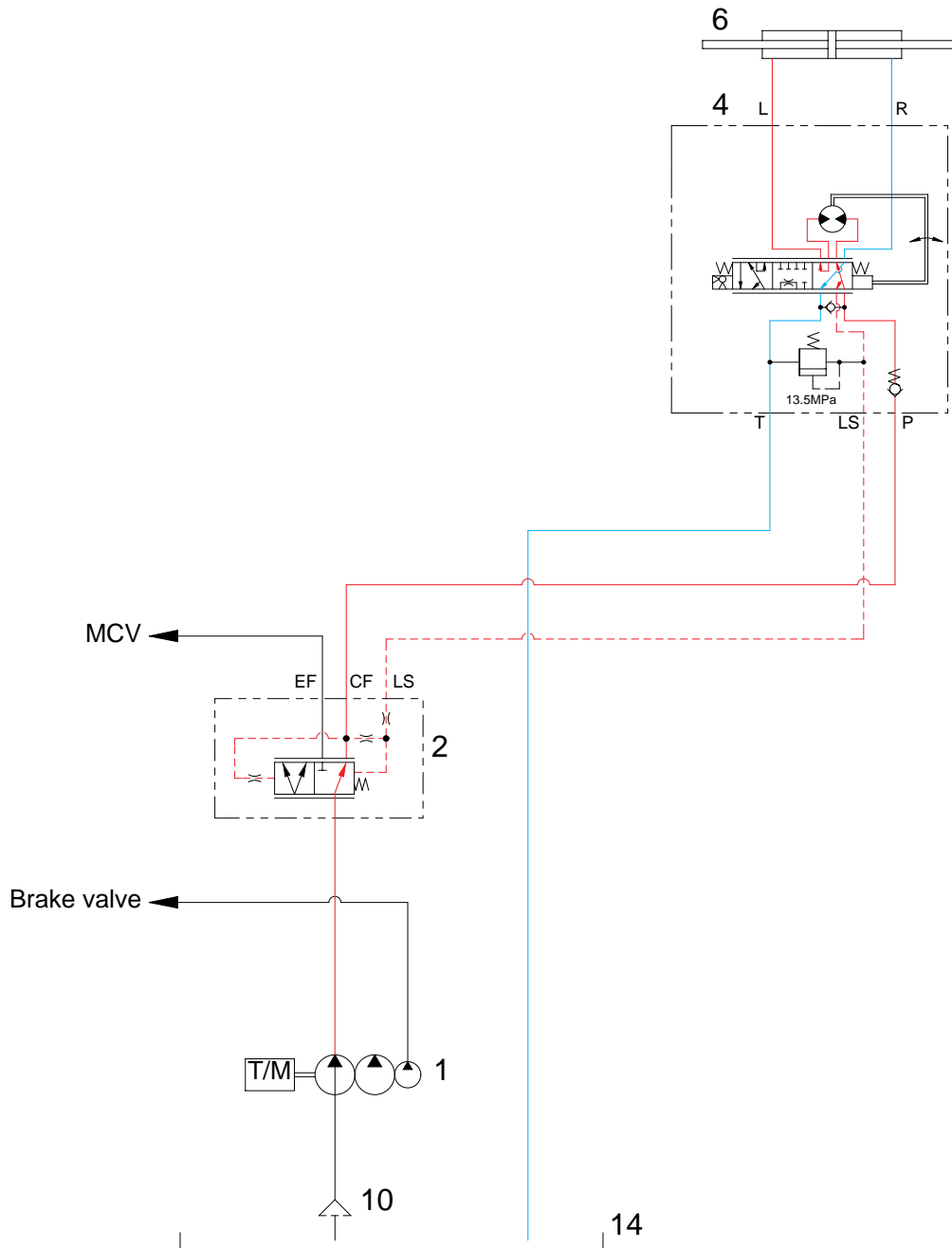

50D7ESE03

When the steering wheel is turned to the left, the spool(G) within the steering unit(4) connected with steering column turns in left hand direction.

At this time, the oil discharged from the pump flows into the spool(G) the steering unit through the spool(D) of priority valve and flows the gerotor(H).

Oil flow from the gerotor flows back into the spool(G) where it is directed out the left work port(L).

Oil returned from cylinder returns to hydraulic tank(14).

When the above operation is completed, the machine turns to the left.

3) RIGHT TURN

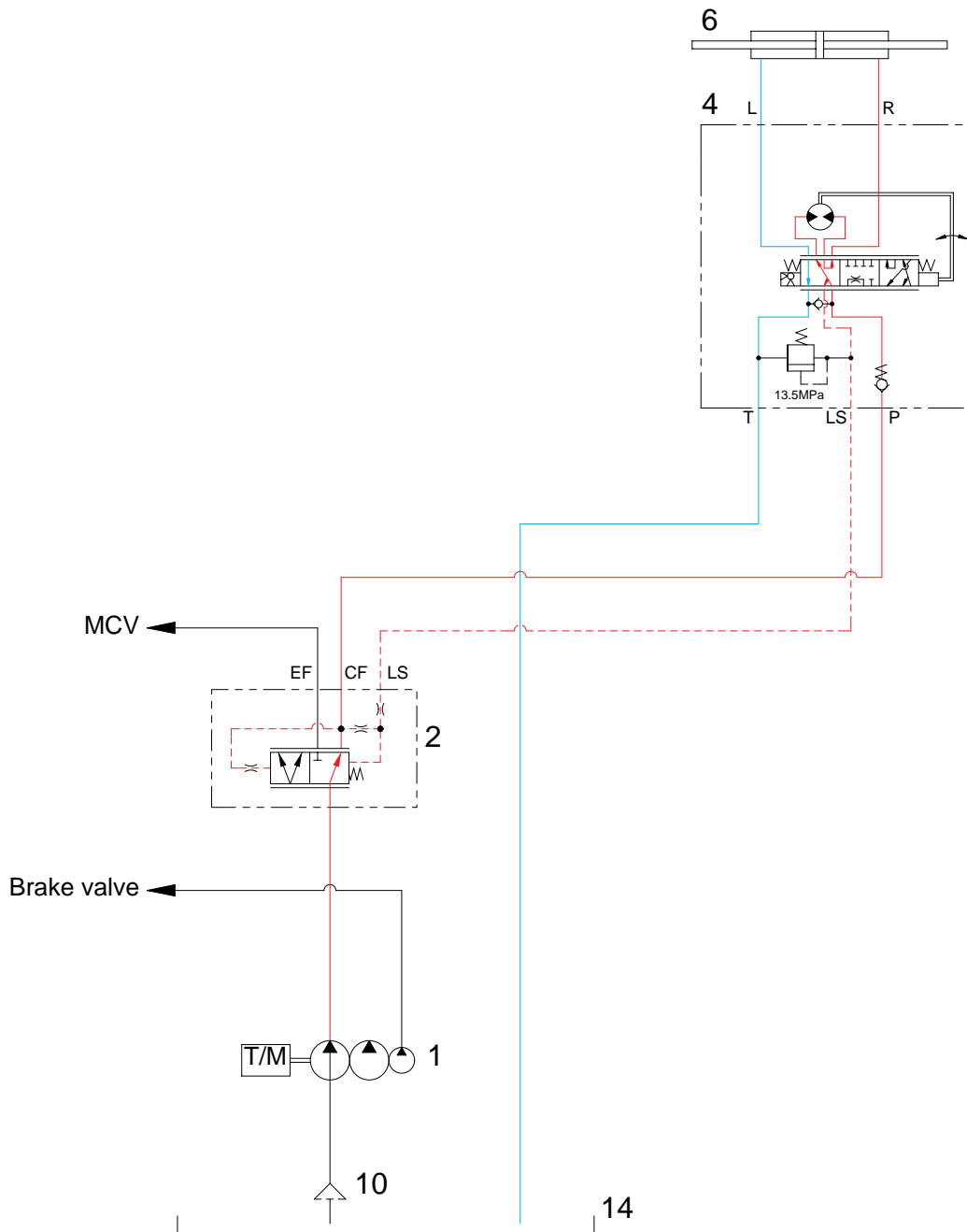

50D7ESE04

When the steering wheel is turned to the right, the spool(G) within the steering unit(4) connected with steering column turns in right hand direction.

At this time, the oil discharged from the pump flows into the spool(G) the steering unit through the spool(D) of priority valve and flows the gerotor(H).

Oil flow from the gerotor flows back into the spool(G) where it is directed out the right work port(R).

Oil returned from cylinder returns to hydraulic tank(14).

When the above operation is completed, the machine turns to the right.

3. STEERING UNIT

1) STRUCTURE

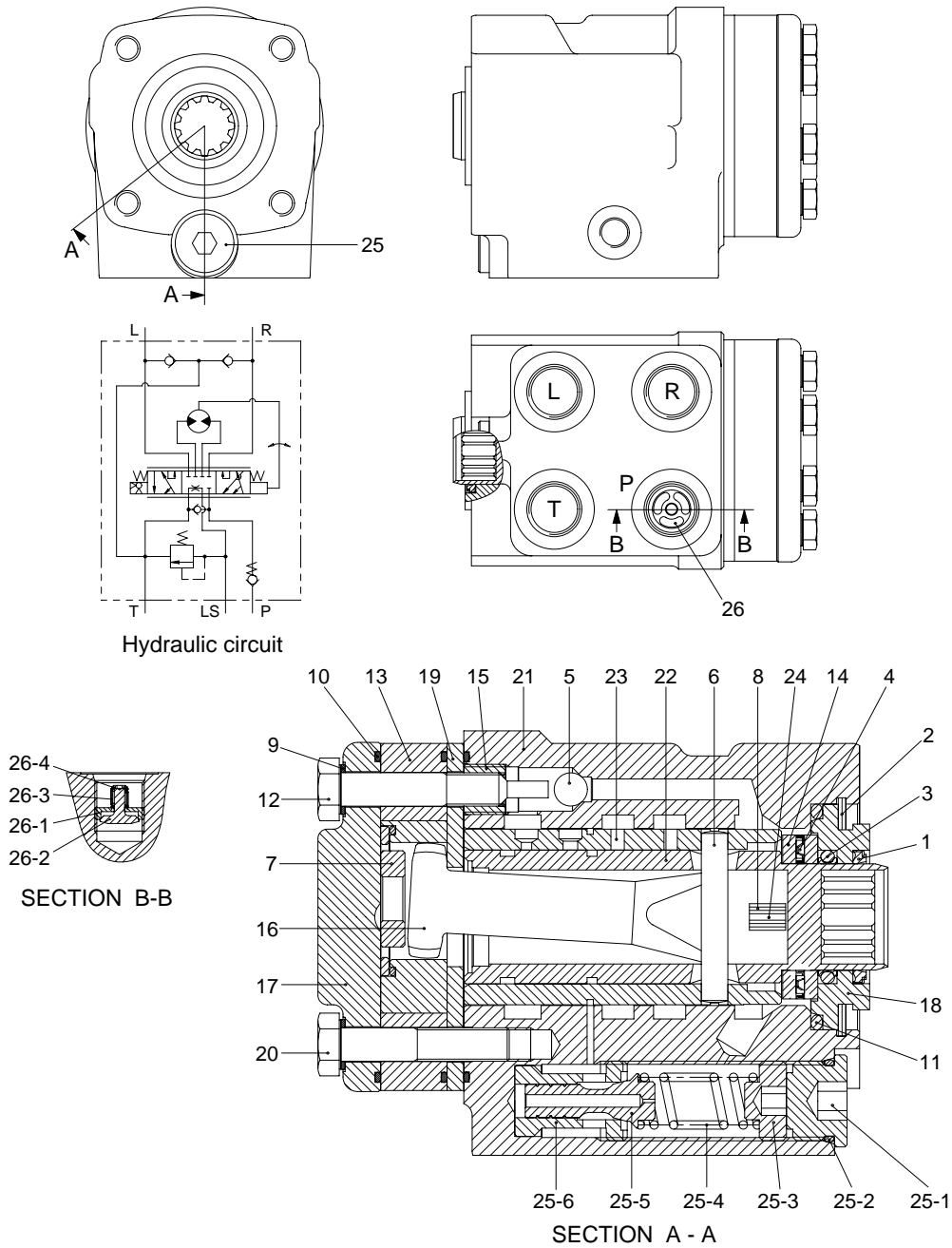

D507SE32

1	Dust seal	10	O-ring	19	Plate	25-3	Spring seat
2	Retaining ring	11	O-ring	20	Cap screw	25-4	Spring
3	Cap seal	12	Roller screw	21	Housing	25-5	Spool
4	Thrust bearing	13	Gerotor set	22	Spool	25-6	Bushing
5	Ball	14	Bearing race	23	Sleeve	26	Check valve
6	Pin	15	Bore screw	24	Plate spring	26-1	Guide
7	Spacer	16	Drive shaft	25	Relief valve	26-2	Shim
8	Center spring	17	End cap	25-1	Plug	26-3	Spring
9	Washer	18	Bushing	25-2	O-ring	26-4	Washer

2) OPERATION

The steering unit is composed of the control valve (rotary valve) and the metering device. The control valve controls the flow of oil from the pump in the interior of the unit depending on the condition of the steering wheel. The metering device is a kind of hydraulic motor composed of a stator and a rotor. It meters the required oil volume, feeds the metered oil to the power cylinder and detects cylinder's motion value, that is, cylinder's motion rate.

When the steering wheel is turned, the spool turns, the oil path is switched and the oil is fed into the metering device. As a result, the rotor is caused to run by oil pressure, and the sleeve is caused to run through the drive shaft and cross pin. Therefore, when the spool is turned, the spool turns by the same value in such a manner that it follows the motion of the spool. Steering motion can be accomplished when this operation is performed in a continuous state.

▲ If the hoses of the steering system are incorrectly connected, the steering wheel can turn very rapidly when the engine is started. Keep clear of the steering wheel when starting the engine.

The centering spring for the spool and sleeve is provided to cause the valve to return to the neutral position. It is therefore possible to obtain a constant steering feeling, which is transmitted to the hands of the driver. Return to the center position occurs when the steering wheel is released.

4. PRIORITY VALVE

1) STRUCTURE

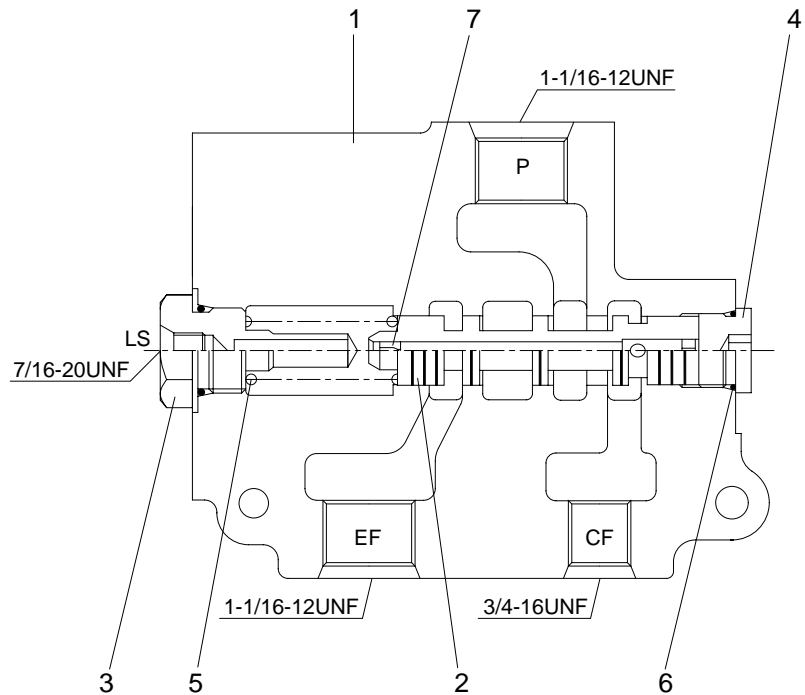
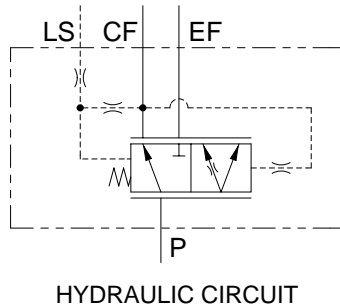

50DS7ESE06

- | | | | | | |
|---|-------------|---|----------|---|---------|
| 1 | Body | 4 | End plug | 7 | Orifice |
| 2 | Spool | 5 | Spring | | |
| 3 | Spring plug | 6 | O-ring | | |

2) OPERATION

The oil from the hydraulic gear pump flows to the priority valve.

The priority valve supplies a flow of oil to the steering system and lift, tilt system.

The steering flow is controlled by the steering unit to operate the steering cylinder.

The remainder of the oil flow from the pump flows to the main control valve.

5. STEERING AXLE

1) STRUCTURE

※ Do not remove the stopper bolt unless necessary.

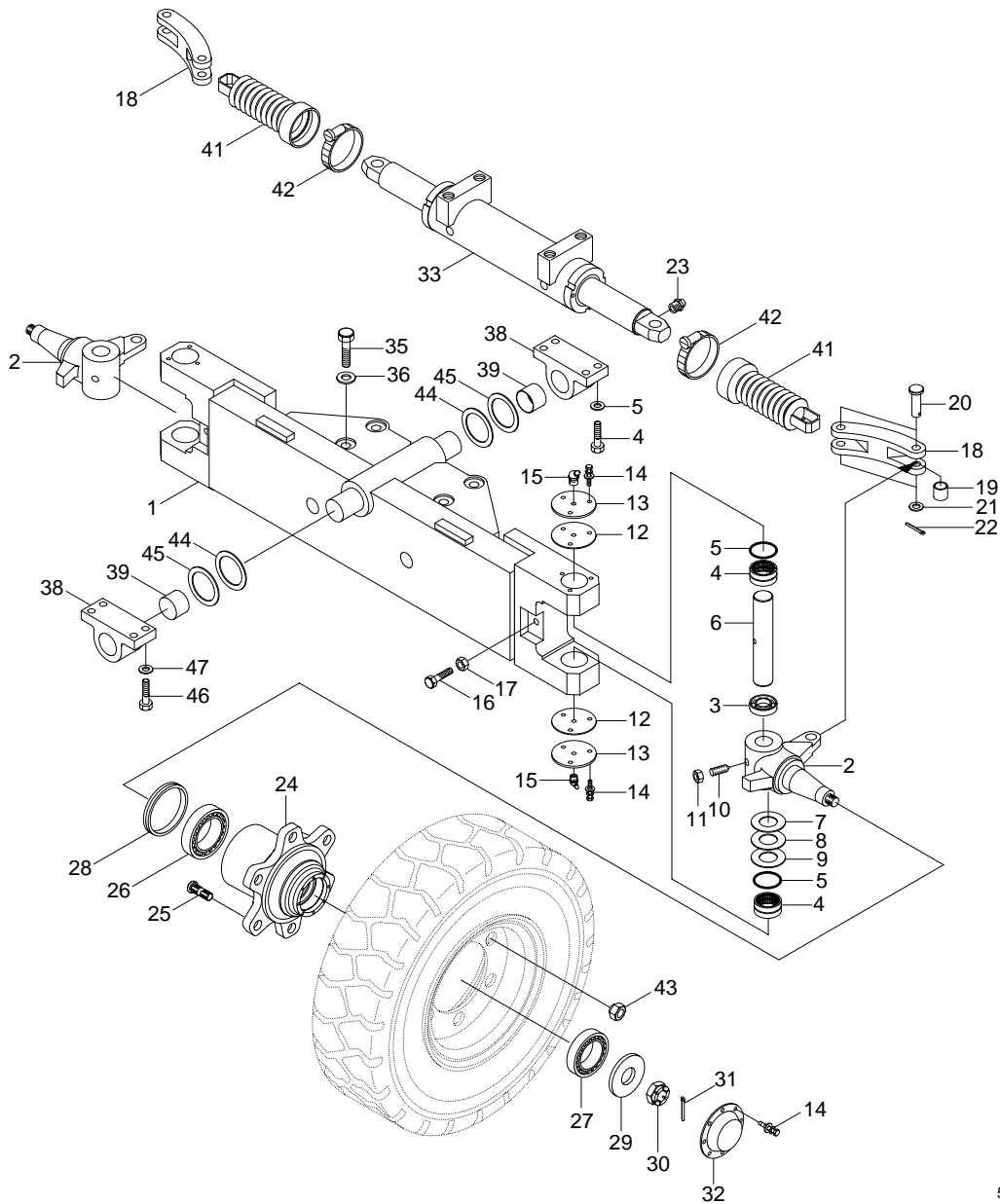

50DS7ESE24

1	Steering axle	12	Gasket	23	Grease nipple	35	Cover
2	Knuckle	13	Cover	24	Hub	36	Hexagon bolt
3	Thrust bearing	14	Bolt w/washer	25	Hub bolt	38	Support
4	Needle bearing	15	Grease nipple	26	Taper roller bearing	39	Bushing
5	Oil seal	16	Hexagon bolt	27	Taper roller bearing	41	Steer cylinder boot
6	King pin	17	Hexagon nut	28	Oil seal	42	Clamp
7	Thrust washer	18	Link	29	Special washer	43	Hub nut
8	Shim washer	19	Inner race bushing	30	Lock nut	44	Shim(1.0t)
9	Shim washer	20	Link pin	31	Split pin	45	Shim(0.5t)
10	Set screw	21	Special washer	32	Hub cap	46	Hexagon bolt
11	Hexagon nut	22	Split pin	33	Steering cylinder	47	Hardened washer

2) TIGHTENING TORQUE AND SPECIFICATION

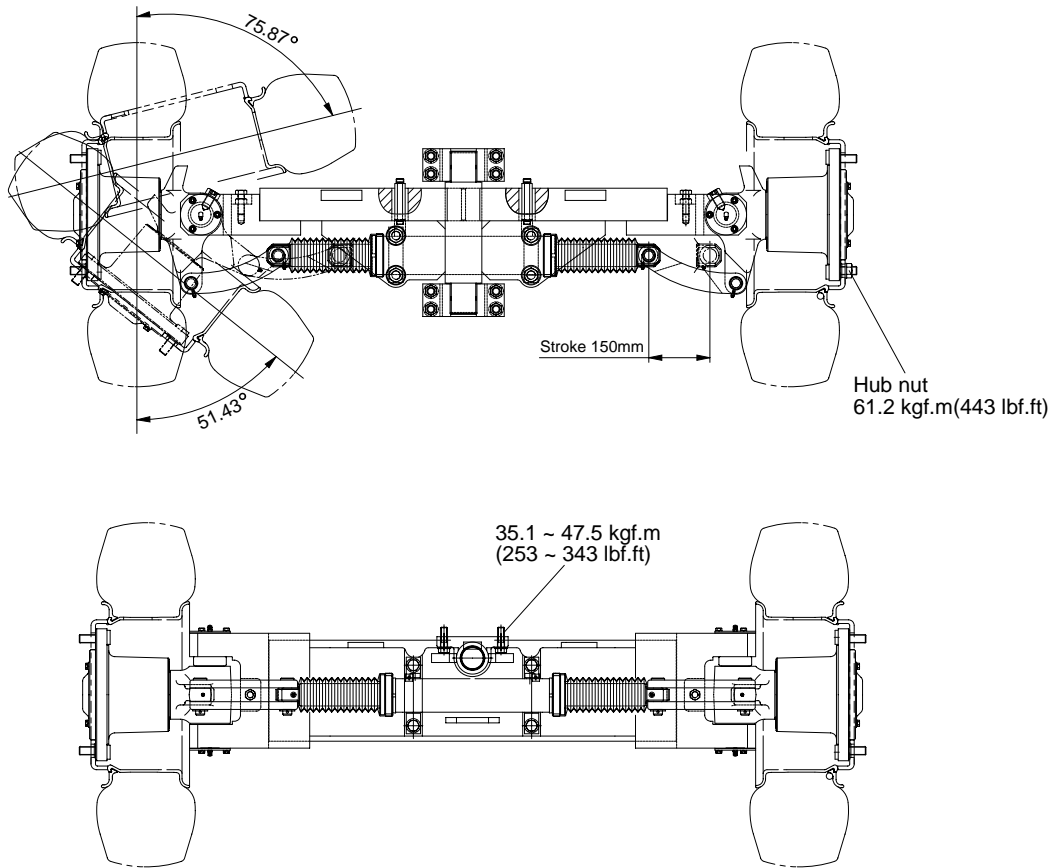

50DS7ESE07

Type	Unit	Center pin support single shaft
Structure of knuckle	-	Elliott type
Toe-in	degree	0
Camber	degree	0
Caster	degree	0
King pin angle	degree	0
Max steering angle of wheels(Inside/Outside)	degree	75.87/ 51.43
Tread	mm(in)	1604(63.1)

GROUP 2 OPERATIONAL CHECKS AND TROUBLESHOOTING

1. OPERATIONAL CHECKS

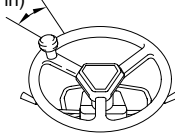
Check item	Checking procedure								
<p>Steering wheel</p> <p>30-60mm (1.2-2.4 in)</p> 	<ul style="list-style-type: none"> • Set rear wheels facing straight forward, then turn steering wheel to left and right. Measure range of steering wheel movement before rear wheel starts to move. Range should be 30~60mm at rim of steering wheel. If play is too large, adjust at gear box. • Test steering wheel play with engine at idling. 								
<p>Knuckle</p>	<ul style="list-style-type: none"> • Check knuckle visually or use crack detection method. If the knuckle is bent, the tire wear is uneven, so check tire wear. 								
<p>Steering axle</p>	<ul style="list-style-type: none"> • Put camber gauge in contact with hub and measure camber. If camber is not within $0 \pm 0.5^\circ$; rear axle is bent. • Ask assistant to drive machine at minimum turning radius. • Fit bar and a piece of chalk at outside edge of counterweight to mark line of turning radius. • If minimum turning radius is not within $\pm 100\text{mm}$ ($\pm 4\text{in}$) of specified value, adjust turning angle stopper bolt. <p>Min turning radius(Outside)</p> <table border="1" style="margin-left: 20px; border-collapse: collapse; text-align: center;"> <tbody> <tr> <td style="padding: 2px 10px;">50D-7E</td> <td style="padding: 2px 10px;">3270mm(128in)</td> </tr> <tr> <td style="padding: 2px 10px;">60D-7E</td> <td style="padding: 2px 10px;">3315mm(130in)</td> </tr> <tr> <td style="padding: 2px 10px;">70D-7E</td> <td style="padding: 2px 10px;">3270mm(128in)</td> </tr> <tr> <td style="padding: 2px 10px;">80D-7E</td> <td style="padding: 2px 10px;">3600mm(141in)</td> </tr> </tbody> </table>	50D-7E	3270mm(128in)	60D-7E	3315mm(130in)	70D-7E	3270mm(128in)	80D-7E	3600mm(141in)
50D-7E	3270mm(128in)								
60D-7E	3315mm(130in)								
70D-7E	3270mm(128in)								
80D-7E	3600mm(141in)								
<p>Hydraulic pressure of power steering</p>	<p>Remove plug from outlet port of flow divider and install oil pressure gauge. Turn steering wheel fully and check oil pressure.</p> <p>※ Oil pressure : 135 ~ 140 kgf/cm² (132 ~ 137bar)</p>								

2. TROUBLESHOOTING

Problem	cause	Remedy
<p>Steering wheel drags.</p>	<ul style="list-style-type: none"> • Low oil pressure. • Bearing faulty. • Spring spool faulty. • Reaction plunger faulty. • Ball-and-screw assembly faulty. • Sector shaft adjusting screw excessively tight. • Gears poorly meshing. • Flow divider coil spring fatigued. 	<ul style="list-style-type: none"> • Check lockout. Repair. • Clean or replace. • Clean or replace. • Replace. • Clean or replace. • Adjust. • Check and correct meshing. • Replace.
<p>Steering wheel fails to return smoothly.</p>	<ul style="list-style-type: none"> • Bearing faulty. • Reaction plunger faulty. • Ball-and-screw assy faulty • Gears poorly meshing. 	<ul style="list-style-type: none"> • Clean or replace. • Replace. • Clean or replace. • Check and correct meshing.

Problem	cause	Remedy
Steering wheel turns unsteadily. Steering system makes abnormal sound or vibration.	<ul style="list-style-type: none"> • Lockout loosening. • Metal spring deteriorated. • Gear backlash out of adjustment. • Lockout loosening. • Air in oil circuit. 	<ul style="list-style-type: none"> • Retighten. • Replace. • Adjust. • Retighten. • Bleed air.
Abnormal sound heard when steering wheel is turned fully	<p>Valve</p> <ul style="list-style-type: none"> • Faulty. (Valve fails to open.) <p>Piping</p> <ul style="list-style-type: none"> • Pipe(from pump to power steering cylinder) dented or clogged. 	<ul style="list-style-type: none"> • Adjust valve set pressure and check for specified oil pressure. • Repair or replace.
Piping makes abnormal sounds.	<p>Oil pump</p> <ul style="list-style-type: none"> • Lack of oil. • Oil inlet pipe sucks air. • Insufficient air bleeding. 	<ul style="list-style-type: none"> • Add oil. • Repair. • Bleed air completely.
Valve or valve unit makes abnormal sounds.	<p>Oil pump</p> <ul style="list-style-type: none"> • Oil inlet pipe sucks air. <p>Valve</p> <ul style="list-style-type: none"> • Faulty. (Unbalance oil pressure) <p>Piping</p> <ul style="list-style-type: none"> • Pipe(from pump to power steering) dented or clogged. • Insufficient air bleeding. 	<ul style="list-style-type: none"> • Repair or replace. • Adjust valve set pressure and check specified oil pressure. • Repair or replace. • Bleed air completely.
Insufficient or variable oil flow.	<ul style="list-style-type: none"> • Flow control valve orifice clogged. 	<ul style="list-style-type: none"> • Clean
Insufficient or variable discharge pressure.	<p>Piping</p> <ul style="list-style-type: none"> • Pipe(from tank to pipe) dented or clogged. 	<ul style="list-style-type: none"> • Repair or replace.
Steering cylinder head leakage (Piston rod)	<ul style="list-style-type: none"> • Packing foreign material. • Piston rod damage. • Rod seal damage and distortion. • Chrome gilding damage. 	<ul style="list-style-type: none"> • Replace • Grind surface with oil stone. • Replace • Grind
Steering cylinder head thread (A little bit leak is no problem)	<ul style="list-style-type: none"> • O-ring damage. 	<ul style="list-style-type: none"> • Replace
Welding leakage	<ul style="list-style-type: none"> • Cylinder tube damage. 	<ul style="list-style-type: none"> • Tube replace.
Rod	<ul style="list-style-type: none"> • Tube inside damage. • Piston seal damage and distortion 	<ul style="list-style-type: none"> • Grind surface with oil store. • Replace
Piston rod bushing inner diameter excessive gap	<ul style="list-style-type: none"> • Bushing wear. 	<ul style="list-style-type: none"> • Replace

GROUP 3 DISASSEMBLY AND ASSEMBLY

1. STEERING UNIT

1) STRUCTURE

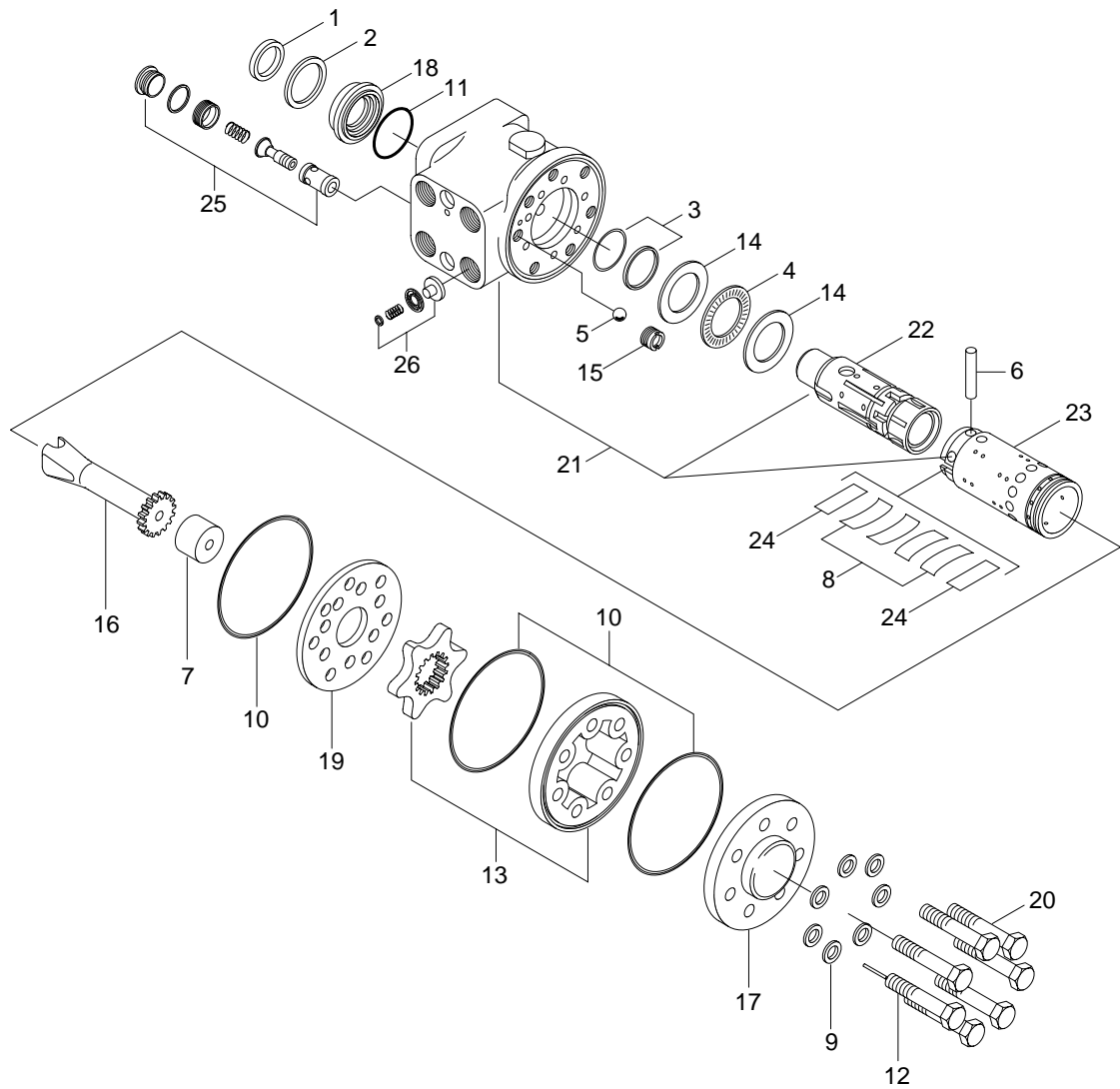

50DS7ESE05

- | | | | | | |
|---|----------------|----|--------------|----|--------------|
| 1 | Dust seal | 10 | O-ring | 19 | Plate |
| 2 | Retaining ring | 11 | O-ring | 20 | Cap screw |
| 3 | Cap seal | 12 | Rolled screw | 21 | Housing |
| 4 | Thrust bearing | 13 | Gerotor set | 22 | Spool |
| 5 | Ball | 14 | Bearing race | 23 | Sleeve |
| 6 | Pin | 15 | Bore screw | 24 | Plate spring |
| 7 | Spacer | 16 | Drive shaft | 25 | Relief valve |
| 8 | Center spring | 17 | End cap | 26 | Check valve |
| 9 | Washer | 18 | Bushing | | |

2) TOOLS

(1) Holding tool.

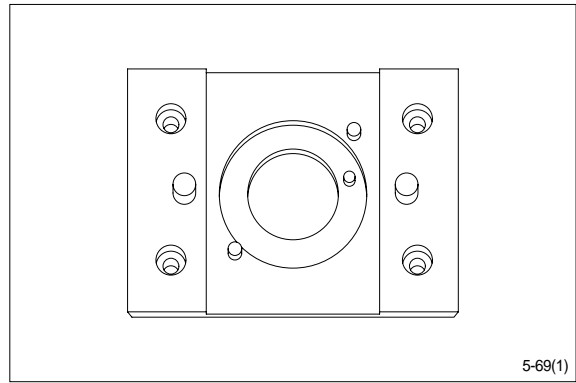

(2) Assembly tool for O-ring and kin-ring.

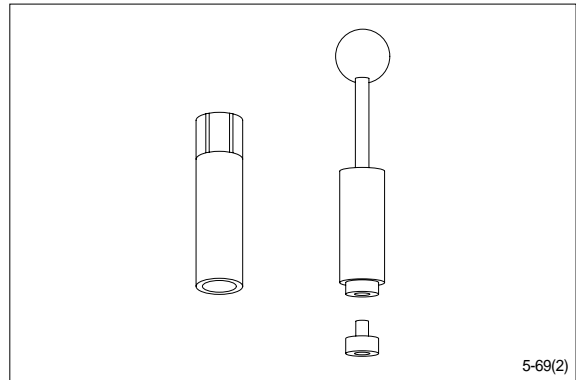

(3) Assembly tool for lip seal.

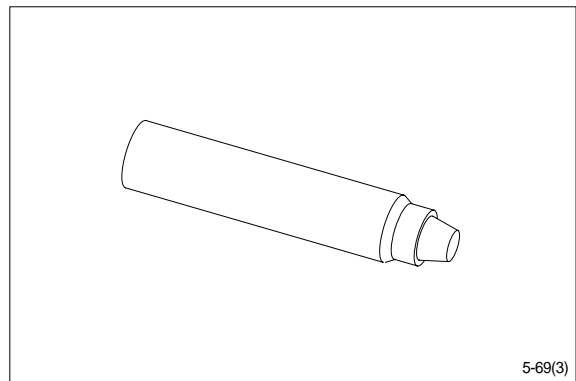

(4) Assembly tool for cardan shaft.

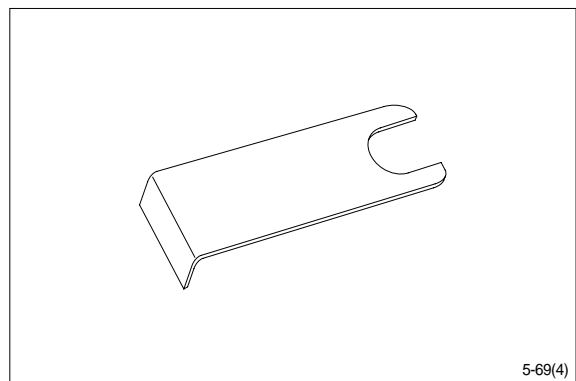

(5) Assembly tool for dust seal.

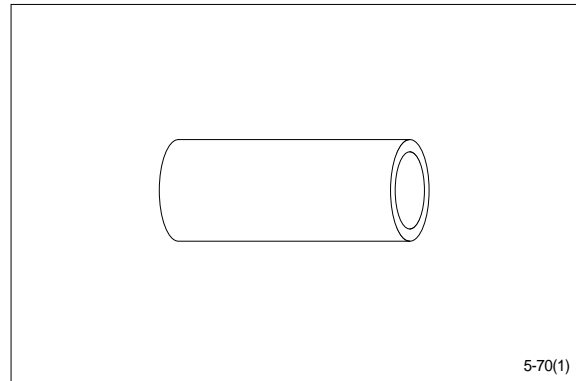

5-70(1)

- (6) Torque wrench 0~7.1kgf · m
(0~54.4lbf · ft)
- 13mm socket spanner
- 6, 8mm and 12mm hexagon sockets
- 12mm screwdriver
- 2mm screwdriver
- 13mm ring spanner
- 6, 8 and 12mm hexagon socket spanners
- Plastic hammer
- Tweezers

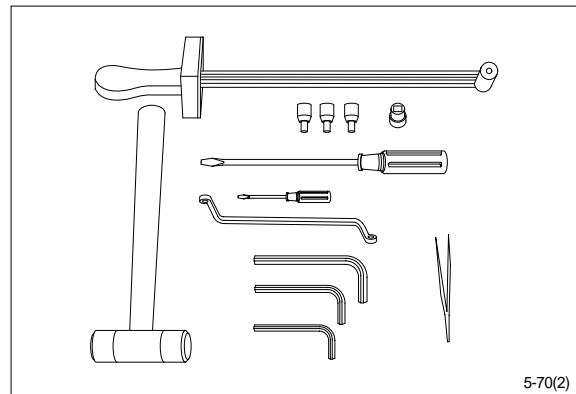

5-70(2)

3) TIGHTENING TORQUE

- L : Left port
- R : Right port
- T : Tank
- P : Pump

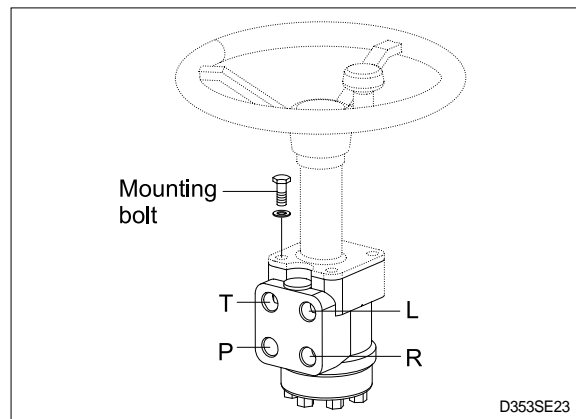

D353SE23

Port	Size	Torque [kgf · m(lbf · ft)]
L	3/4 - 16UNF	6.1±0.6 (44±4.3)
R	3/4 - 16UNF	6.1±0.6 (44±4.3)
T	3/4 - 16UNF	6.1±0.6 (44±4.3)
P	3/4 - 16UNF	6.1±0.6 (44±4.3)
Mounting bolt	M10×1.5	4.0 ±0.5 (29±3.6)

4) DISASSEMBLY

- (1) Disassemble steering column from steering unit and place the steering unit in the holding tool.
Screw out the screws in the end cover(6-off plus one special screw).

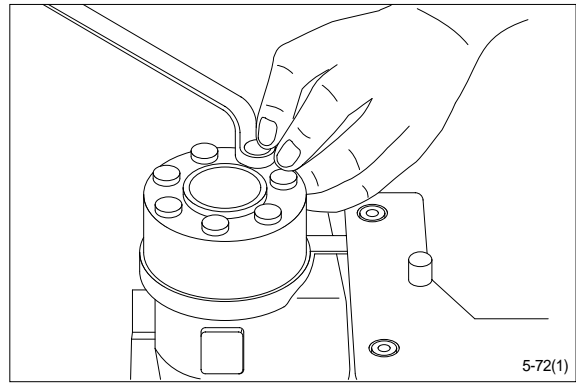

- (2) Remove the end cover, sideways.

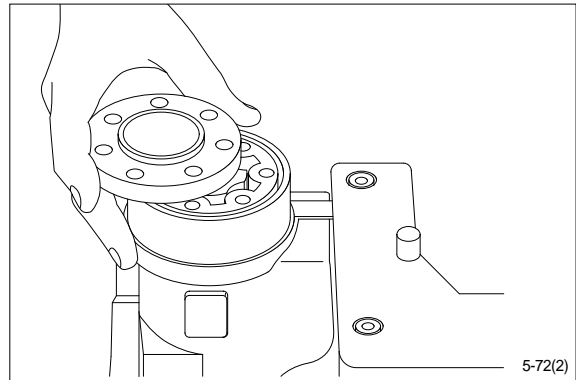

- (3) Lift the gearwheel set(With spacer if fitted) off the unit.
Take out the two O-rings.

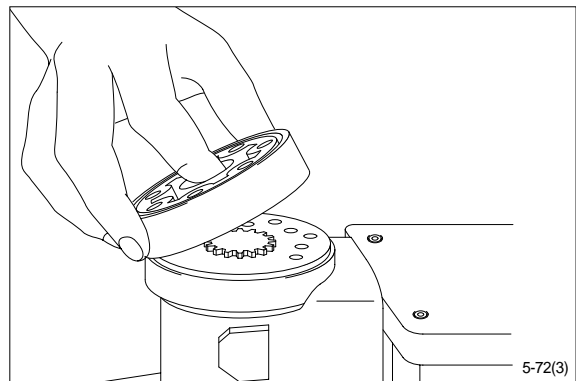

- (4) Remove cardan shaft.

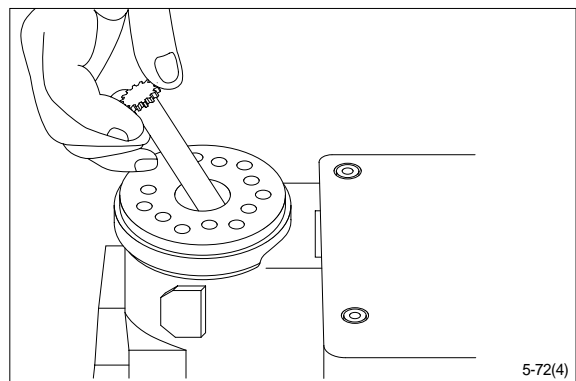

(5) Remove distributor plate.

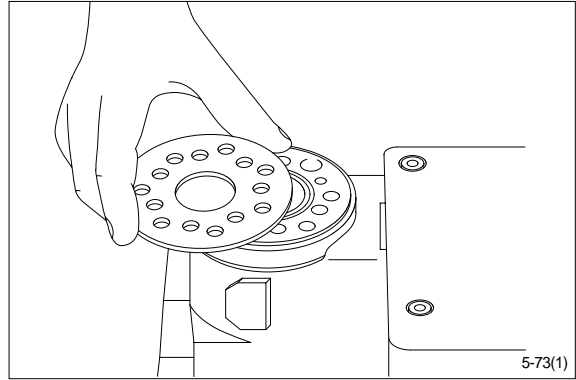

(6) Screw out the threaded bush over the check valve.

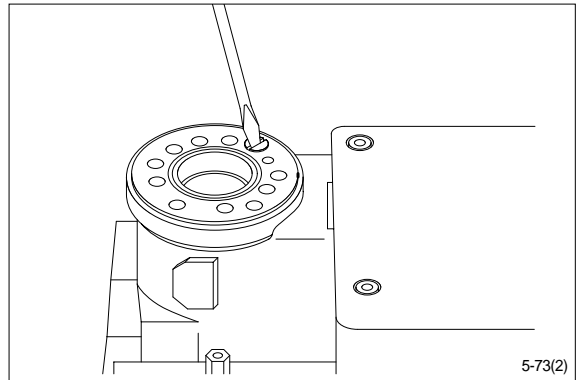

(7) Remove O-ring.

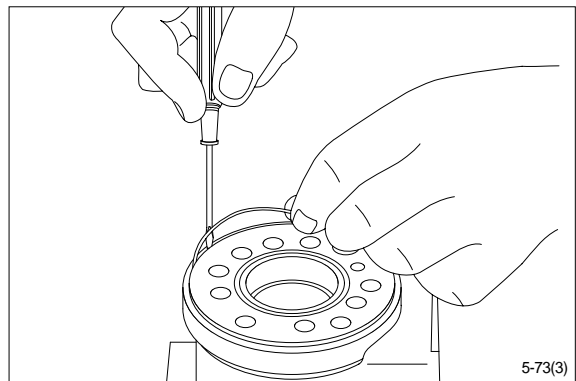

(8) Shake out the check valve ball and suction valve pins and balls.

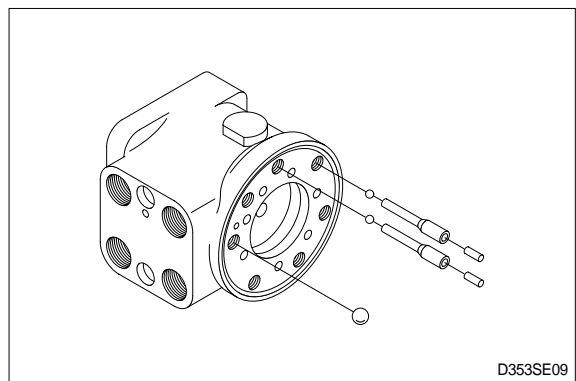

- (9) Take care to keep the cross pin in the sleeve and spool horizontal. The pin can be seen through the open end of the spool. Press the spool inwards and the sleeve, ring, bearing races and thrust bearing will be pushed out of the housing together.

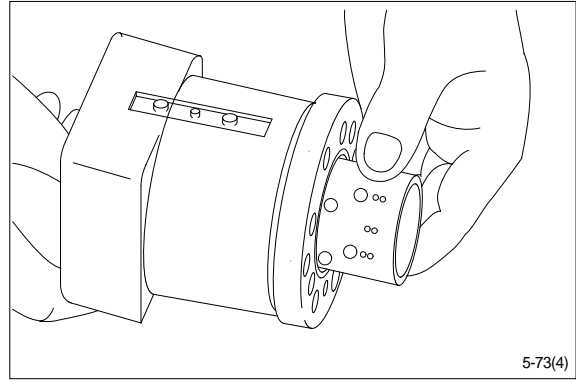

- (10) Take ring, bearing races and thrust bearing from sleeve and spool. The outer (Thin) bearing race can sometimes "stick" in the housing, therefore check that it has come out.

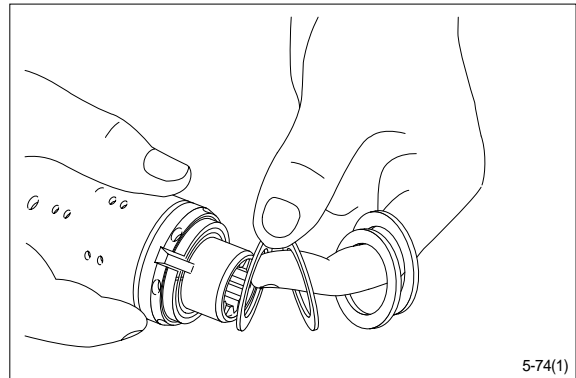

- (11) Press out the cross pin. Use the special screw from the end cover.

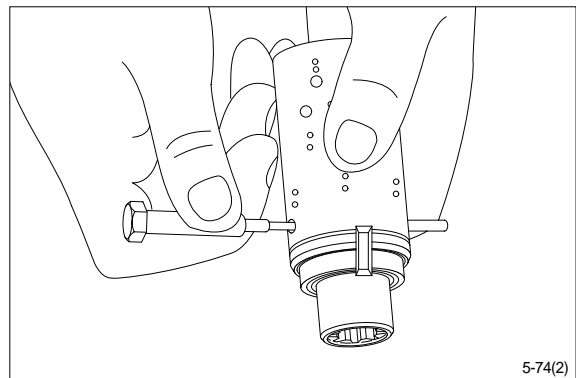

- ※ A small mark has been made with a pumice stone on both spool and sleeve close to one of the slots for the neutral position springs (See drawing). If the mark is not visible, remember to leave a mark of your own on sleeve and spool before the neutral position springs are disassembled.

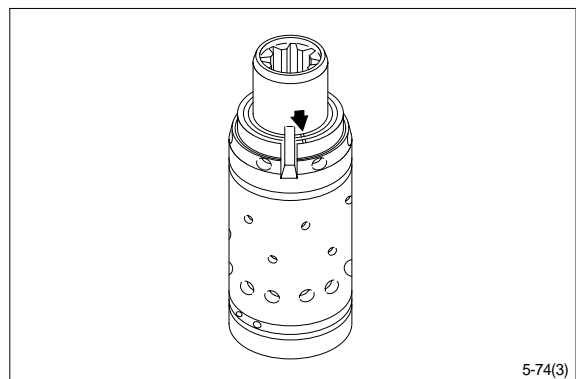

(12) Carefully press the spool out of the sleeve.

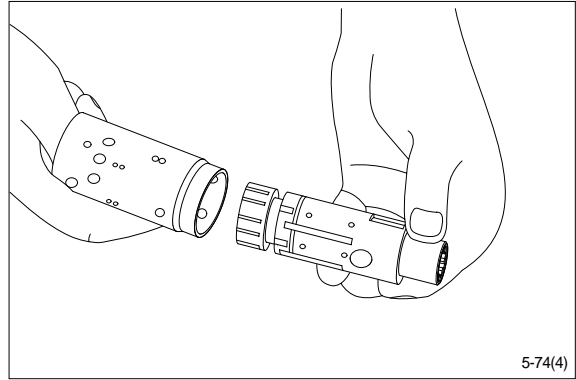

(13) Press the neutral position springs out of their slots in the spool.

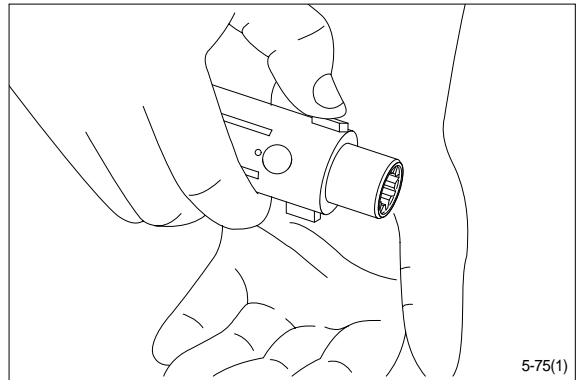

(14) Remove dust seal and O-ring.

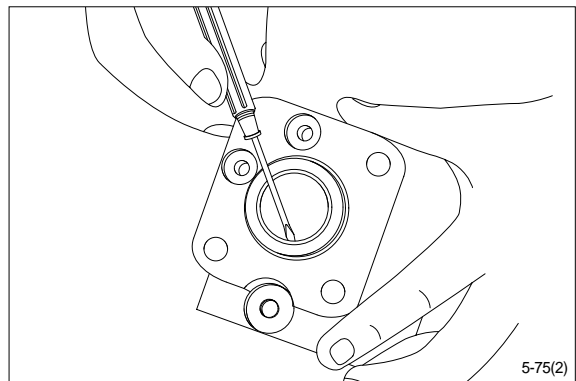

Disassembling the pressure relief valve

(15) Screw out the plug using an 8mm hexagon socket spanner.
Remove seal washers.

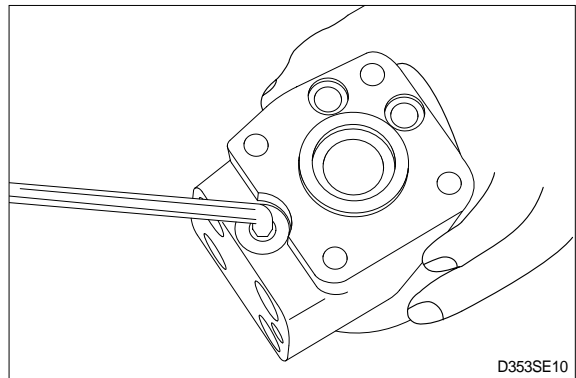

(16) Unscrew the setting screw using an 8mm hexagon socket spanner.

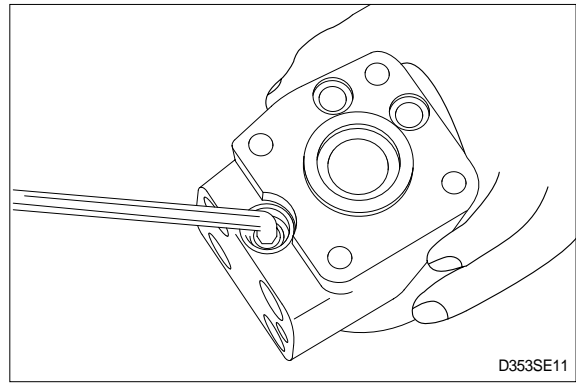

(17) Shake out spring and piston. The valve seat is bonded into the housing and cannot be removed.

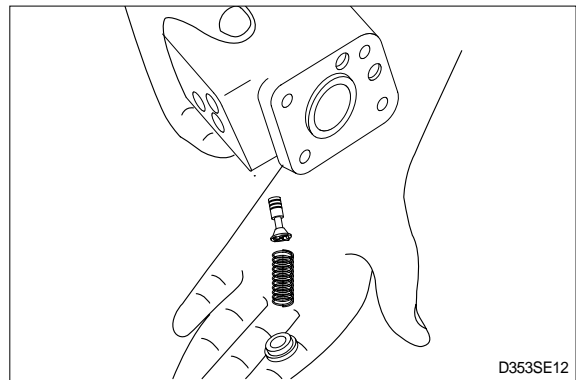

(18) The pressure relief valve is now disassembled.

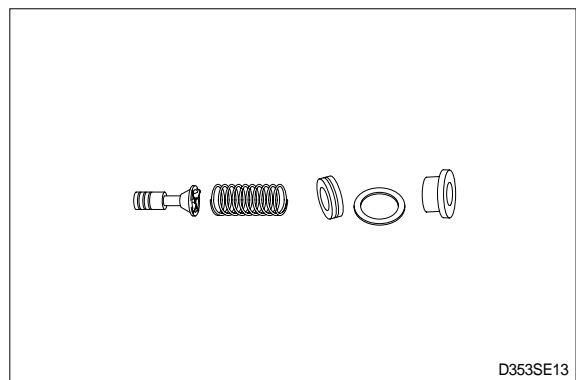

5) ASSEMBLY

(1) Assemble spool and sleeve.

- ※ When assembling spool and sleeve only one of two possible ways of positioning the spring slots is correct. There are three slots in the spool and three holes in the sleeve in the end of the spool / sleeve opposite to the end with spring slots. Place the slots and holes opposite each other so that parts of the holes in the sleeve are visible through the slots in the spool.

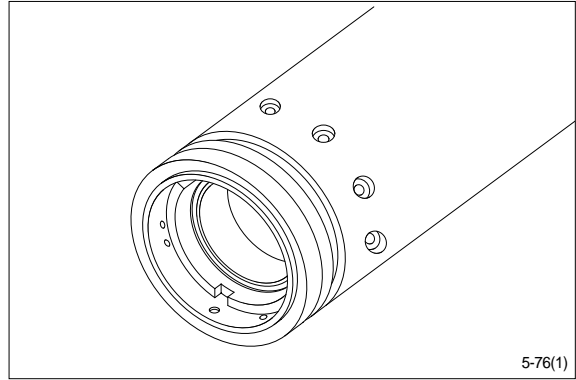

(2) Place the two flat neutral position springs in the slot.

Place the curved springs between the flat ones and press them into place (see assembly pattern).

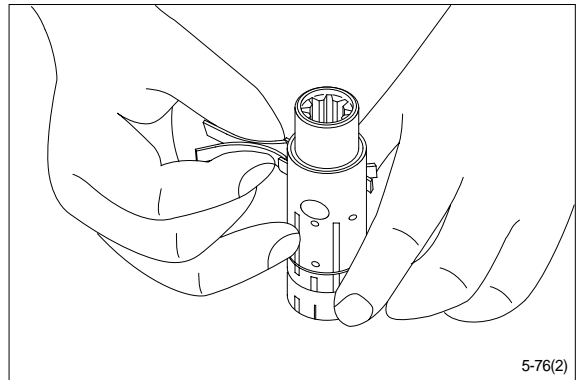

(3) Line up the spring set.

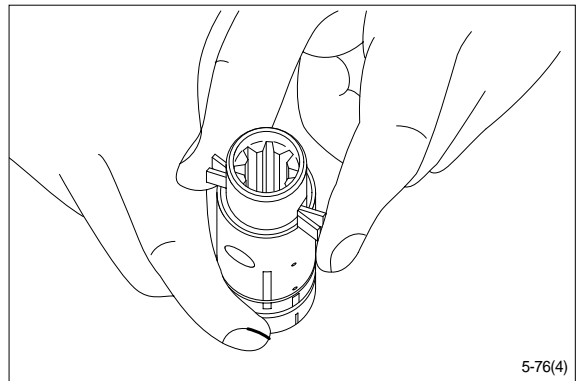

(4) Guide the spool into the sleeve. Make sure that spool and sleeve are placed correctly in relation to each other.

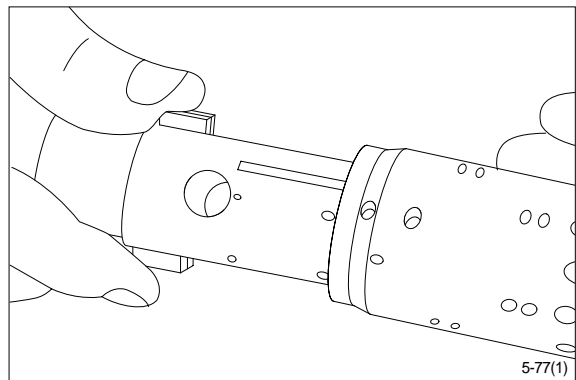

- (5) Press the springs together and push the neutral position springs into place in the sleeve.

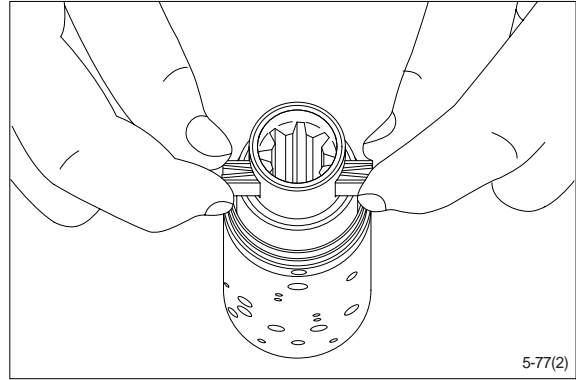

- (6) Line up the springs and center them.

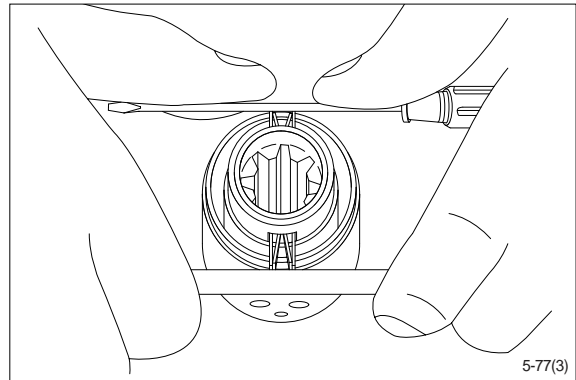

- (7) Guide the ring down over the sleeve.
※ The ring should be able to rotate free of the springs.

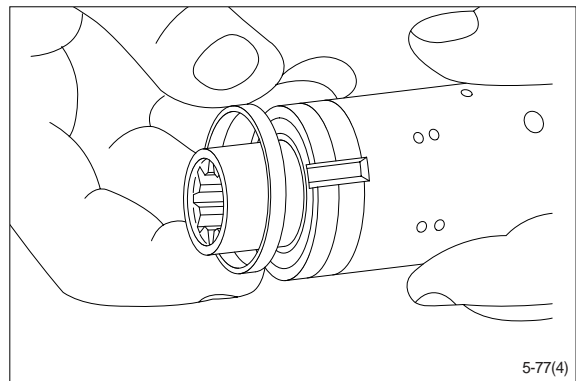

- (8) Fit the cross pin into the spool / sleeve.

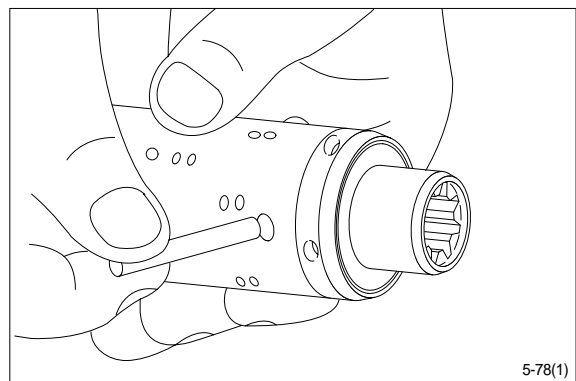

(9) Fit bearing races and needle bearing as shown on below drawing.

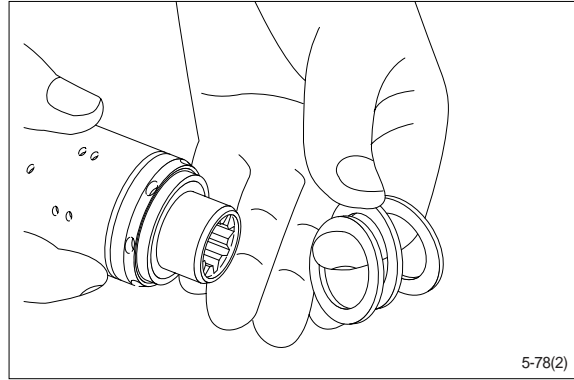

※ **Assembly pattern for standard bearings**

- 1 Outer bearing race
- 2 Thrust bearing
- 3 Inner bearing race
- 4 Spool
- 5 Sleeve

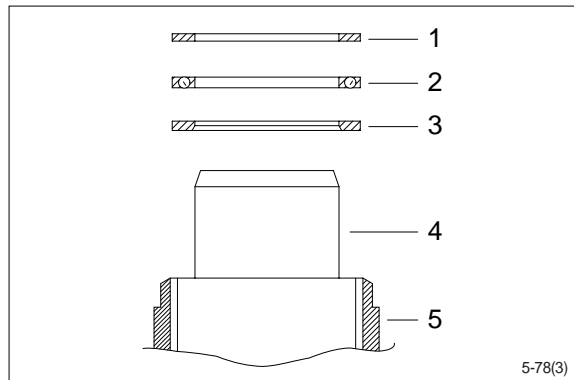

Installation instruction for O-ring

(10) Turn the steering unit until the bore is horizontal. Guide the outer part of the assembly tool into the bore for the spool / sleeve.

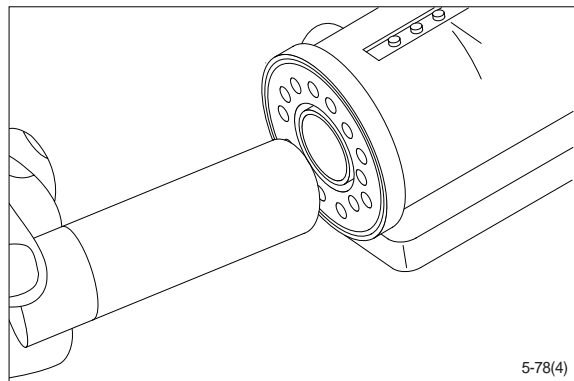

(11) Grease O-ring with hydraulic oil and place them on the tool.

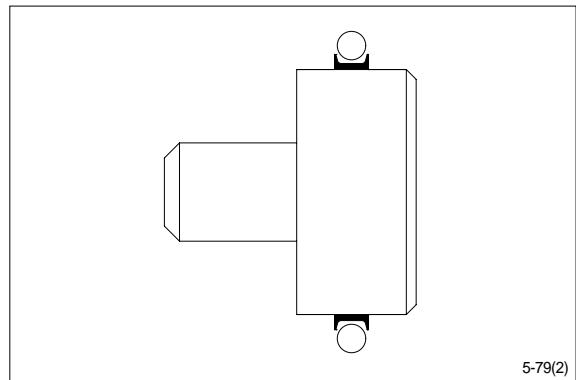
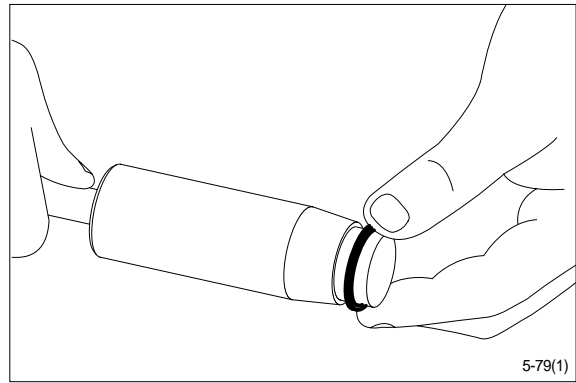

(12) Hold the outer part of the assembly tool in the bottom of the steering unit housing and guide the inner part of the tool right to the bottom.

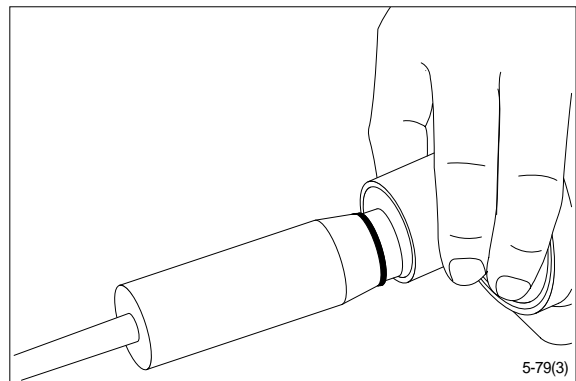

(13) Press and turn the O-ring into position in the housing.

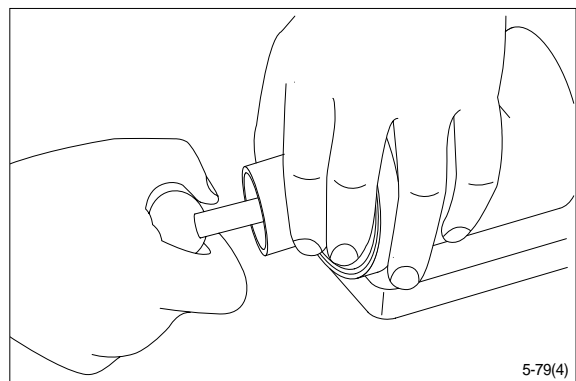

- (14) Draw the inner and outer parts of the assembly tool out of the steering unit bore, leaving the guide from the inner part in the bore.

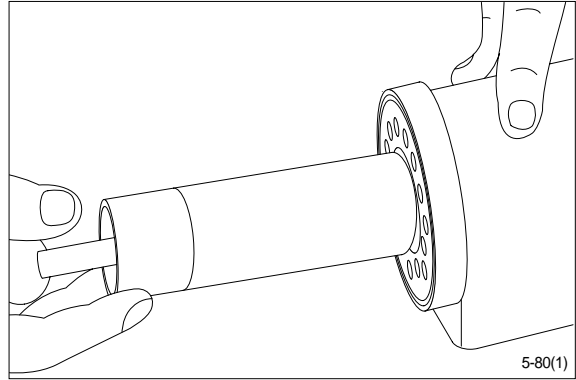

Installation instructions for lip seal

- (15) Lubricate the lip seal with hydraulic oil and place it on the assembly tool.

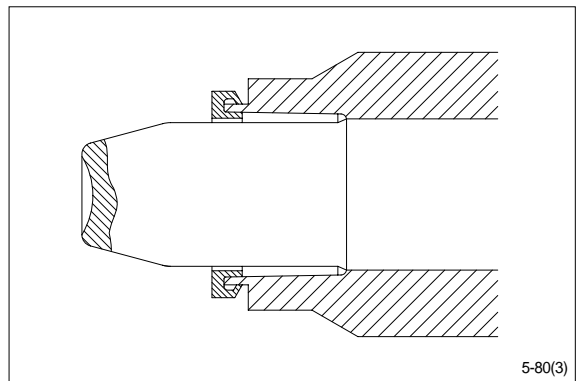
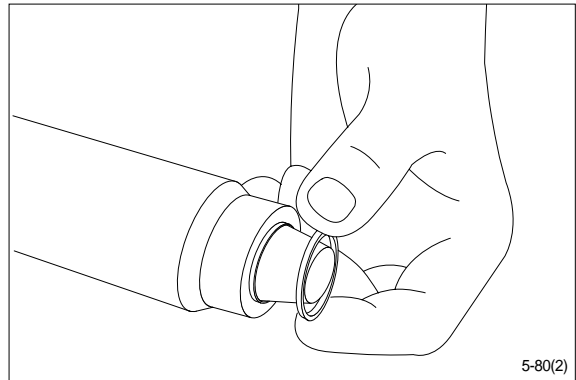

- (16) Guide the assembly tool right to the bottom.

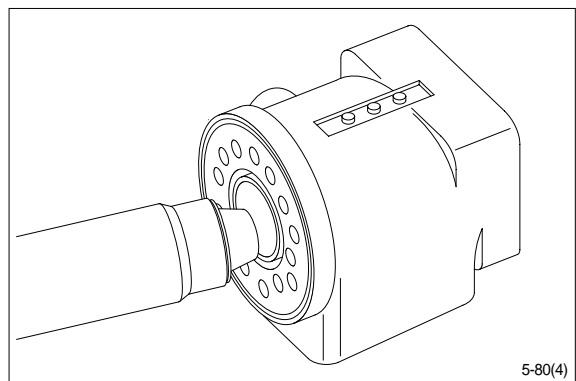

(17) Press and turn the lip seal into place in the housing.

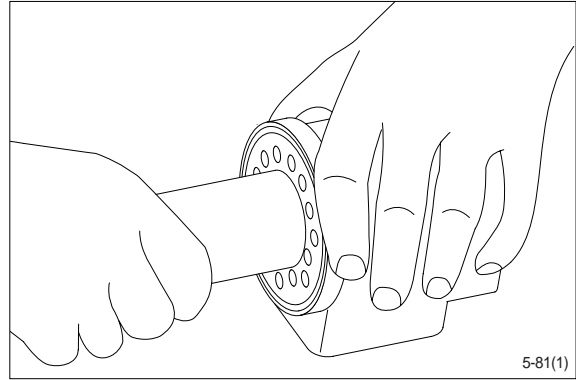

(18) With a light turning movement, guide the spool and sleeve into the bore.
※ Fit the spool set holding the cross pin horizontal.

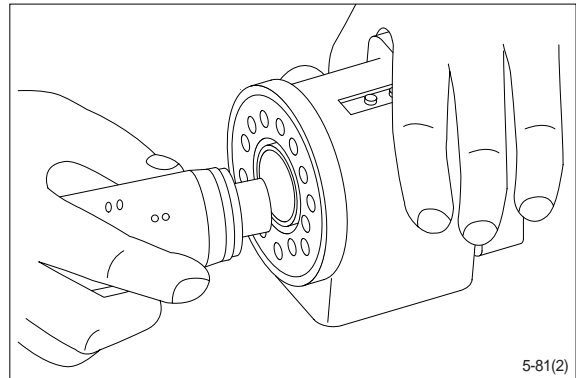

(19) The spool set will push out the assembly tool guide. The O-ring are now in position.

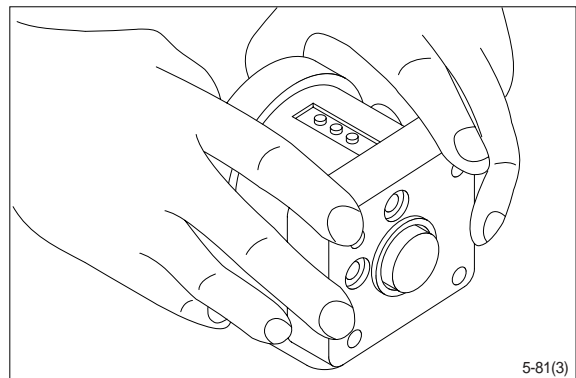

(20) Turn the steering unit until the bore is vertical again. Put the check valve ball into the hole indicated by the arrow.

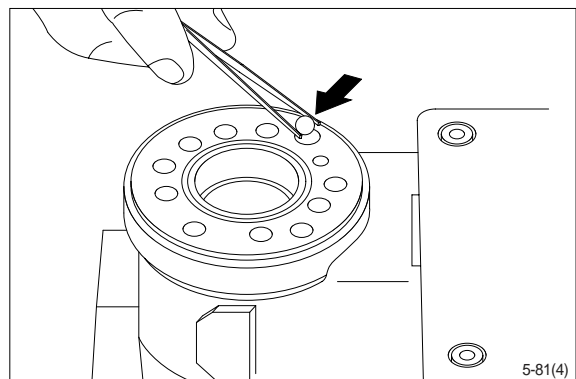

- (21) Screw the threaded bush lightly into the check valve bore. The top of the bush must lie just below the surface of the housing.

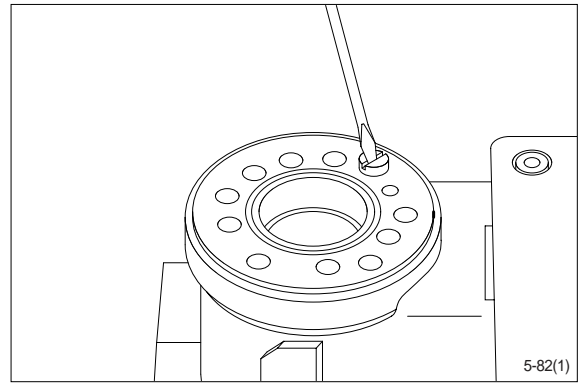

- (22) Grease the O-ring with mineral oil approx. viscosity 500 cSt at 20°C.

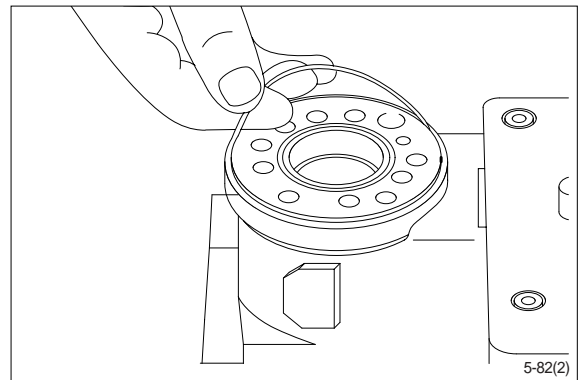

- (23) Place the distributor plate so that the channel holes match the holes in the housing.

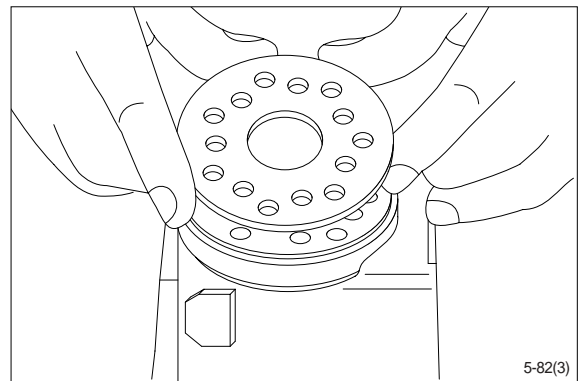

- (24) Guide the cardan shaft down into the bore so that the slot is parallel with the connection flange.

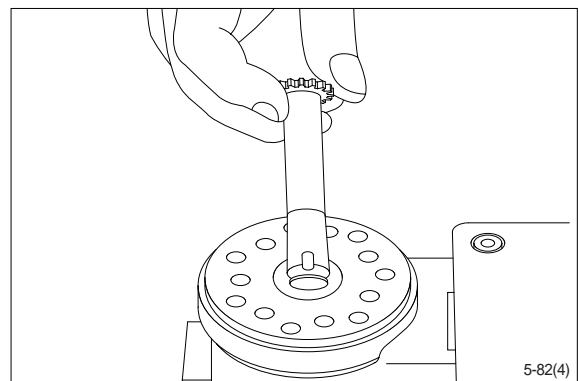

- (25) Place the cardan shaft as shown - so that it is held in position by the mounting fork.

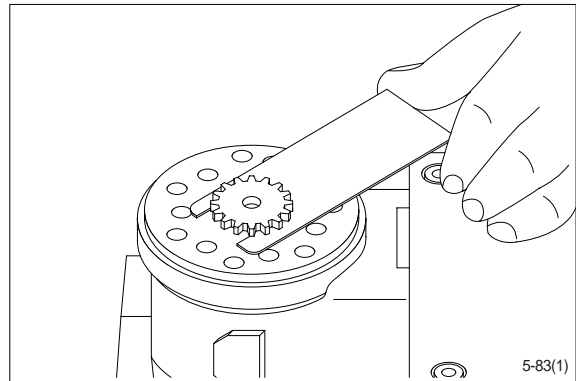

- (26) Grease the two O-rings with mineral oil approx. viscosity 500 cSt at 20°C and place them in the two grooves in the gear rim. Fit the gearwheel and rim on the cardan shaft.

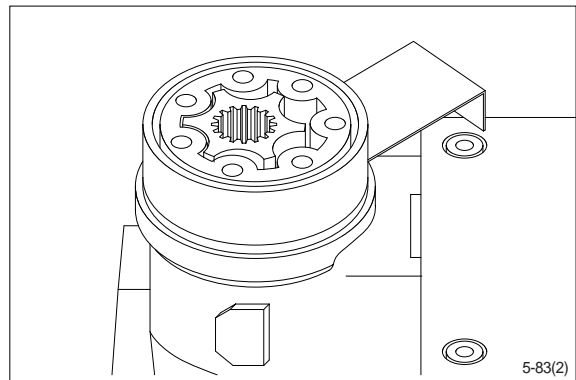

(27) Important

Fit the gearwheel(Rotor) and cardan shaft so that a tooth base in the rotor is positioned in relation to the shaft slot as shown.

Turn the gear rim so that the seven through holes match the holes in the housing.

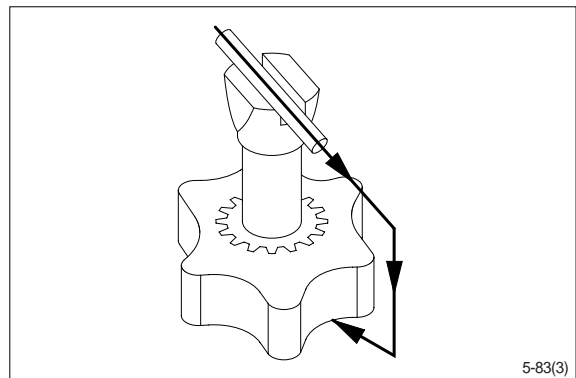

- (28) Fit the spacer, if any.

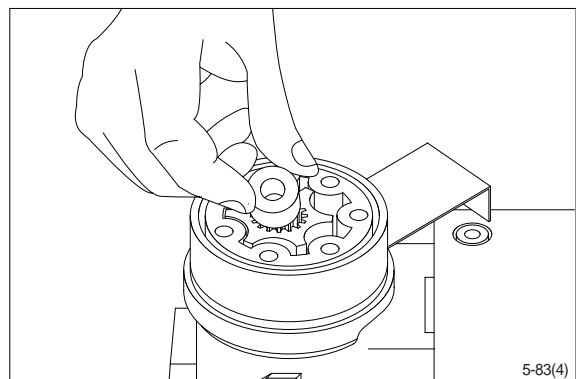

(29) Place the end cover in position.

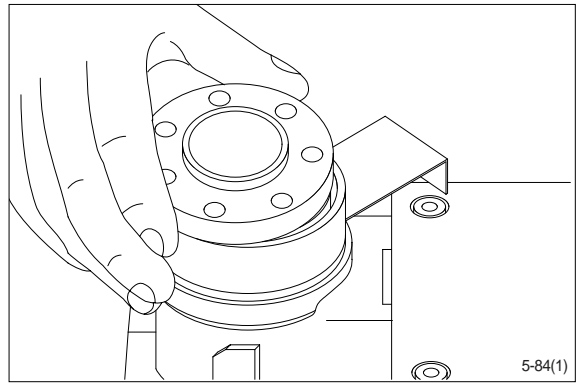

(30) Fit the special screw with washer and place it in the hole shown.

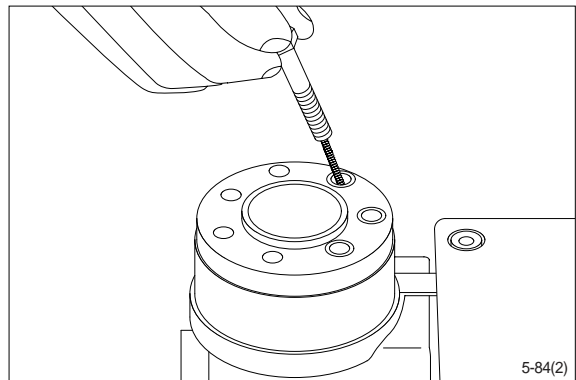

(31) Fit the six screws with washers and insert them. Cross-tighten all the screws and the rolled pin.

- Tightening torque : $4.0 \pm 0.5 \text{kgf} \cdot \text{m}$
($28.9 \pm 3.6 \text{lb} \cdot \text{ft}$)

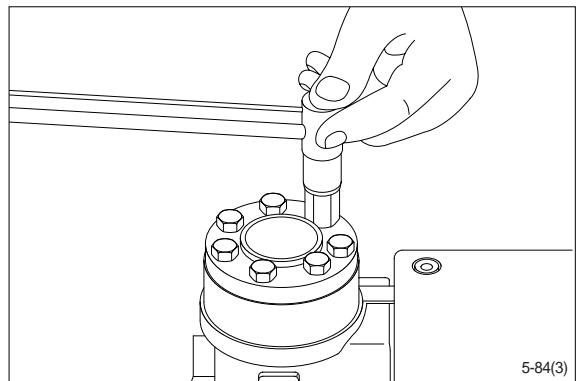

(32) Place the dust seal ring in the housing.

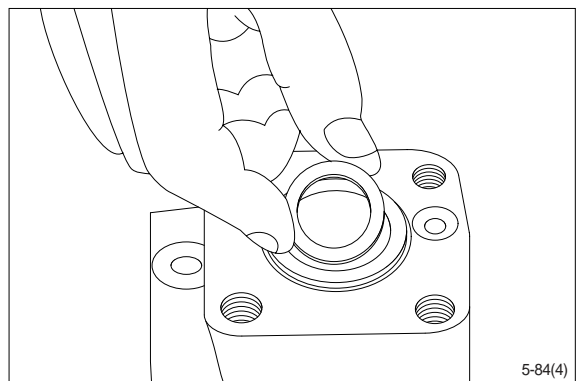

(33) Fit the dust seal ring in the housing.

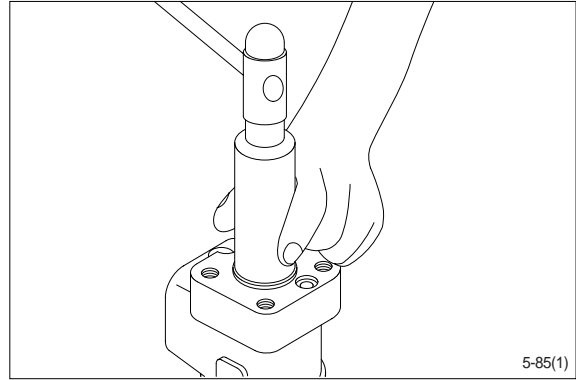

(34) Press the plastic plugs into the connection ports.

※ Do not use a hammer!

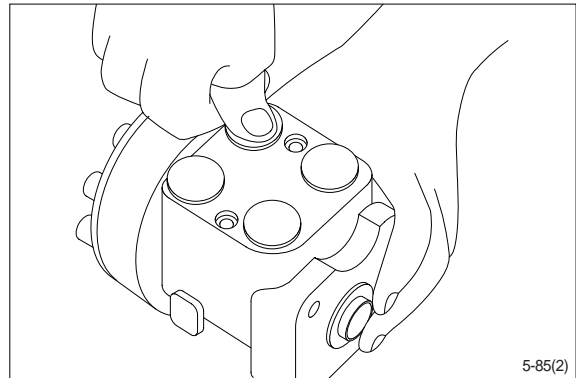

2. PRIORITY VALVE

1) STRUCTURE

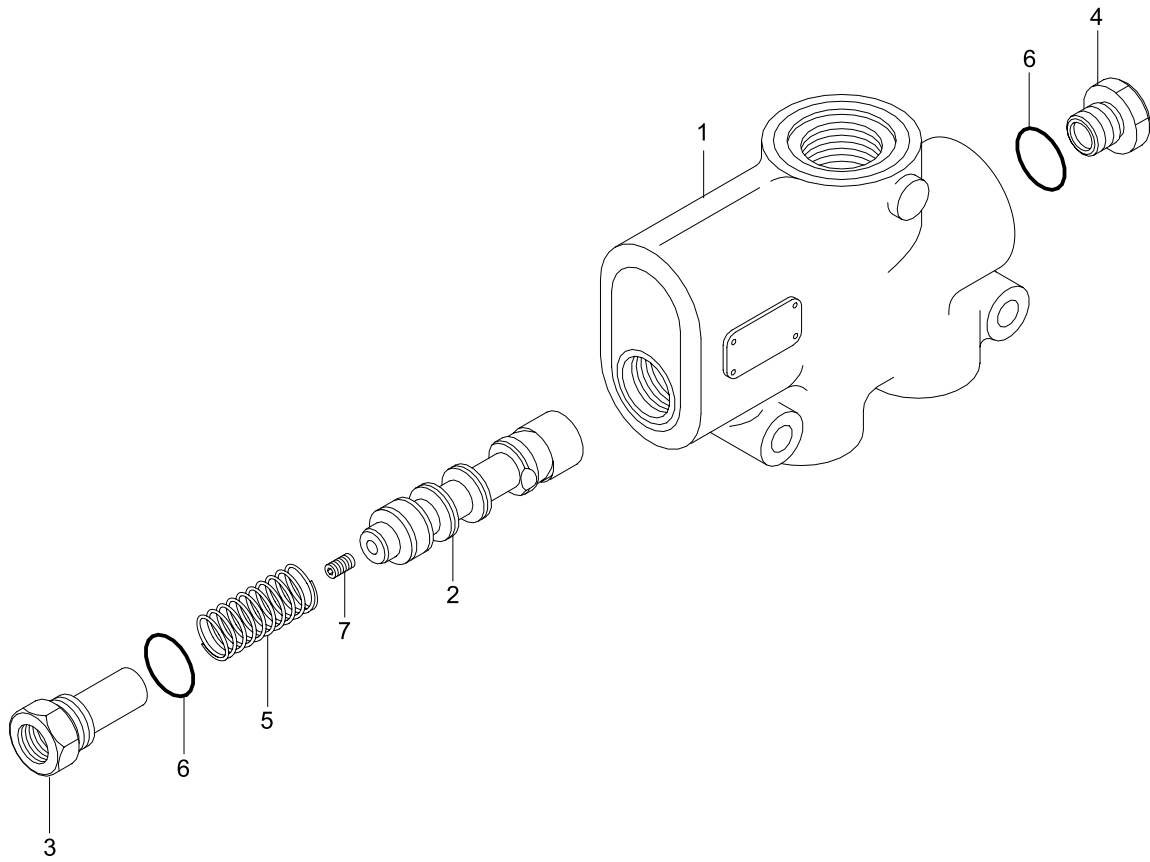

50DS7ESE08

1 Body
2 Spool
3 Spring plug

4 End plug
5 Spring
6 O-ring

7 Orifice

2) DISASSEMBLY

- ※ Cleanliness is the primary means of assuring satisfactory the priority valve life.
Select clean place.
Before removing the piping, clean the surrounding area of valve ports.

- (1) Fix the body(1) in a vise with copper or lead sheets.
Do not over tighten jaws.
- (2) Loosen plug(3) for LS port.

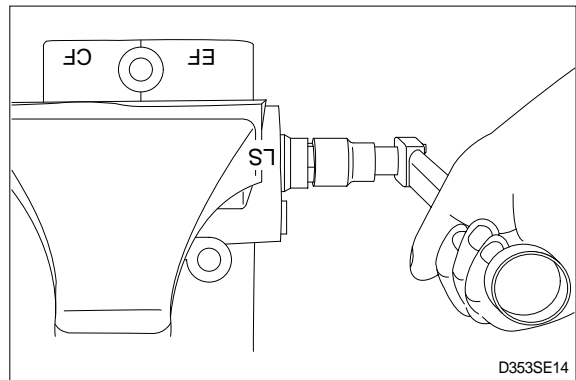

- (3) Remove spring(5).

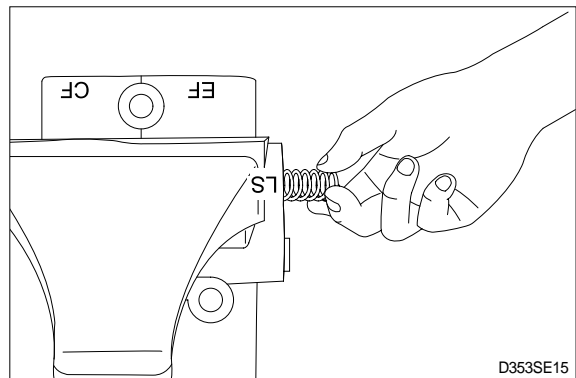

- (4) Remove spool assy(2).
※ Can't remove the orifice(7) from spool(2), because the orifices were locked at the spool.

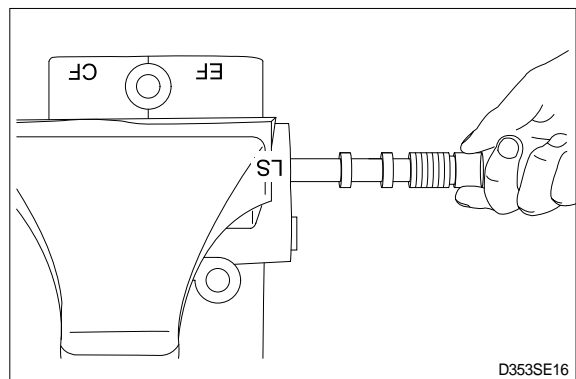

- (5) Remove plug(4) and separate O-ring(6) and plug(3, 4) individually.

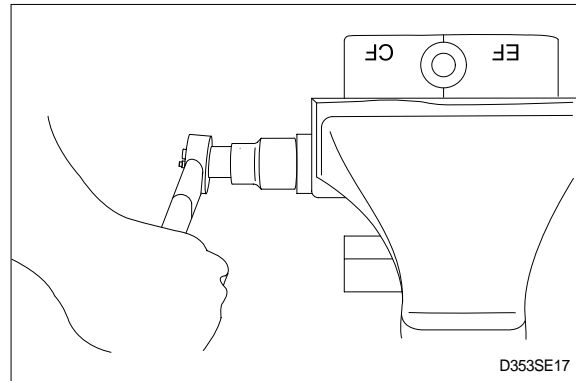

3) ASSEMBLY

- ※ Clean all metal parts in clean solvent and blow dry with air and correct any damage, burrs and rust.
- ※ Do not wipe dry with cloth or paper towel.
- ※ Replace seals such as O-ring with new ones as a rule and coat with grease.

- (1) Fix the body(1) in a vise.

- (2) Insert the spool(2).

- ※ Secure the spool(2) remain in their correct direction.
- ※ Secure the spool(2) to move smoothly by finger.

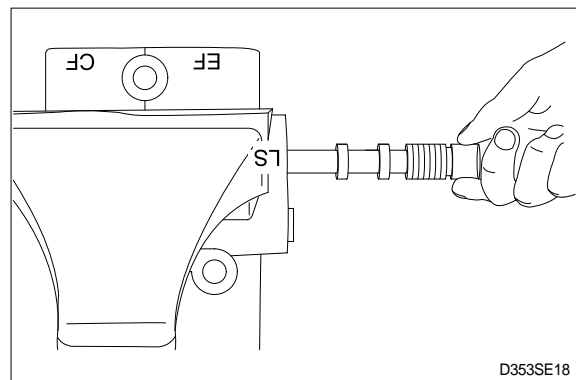

- (3) Insert the spring(5) into the body(1).

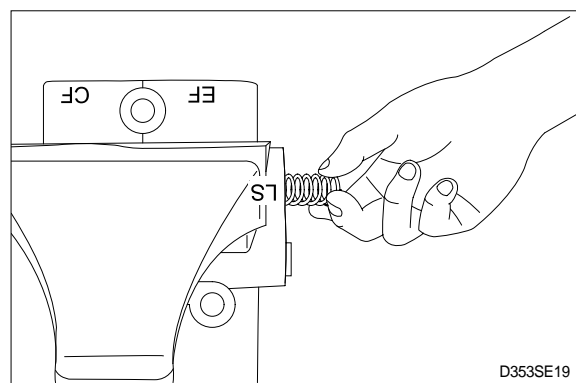

- (4) Install the O-ring(6) onto plug(3, 4) and install the plug(3, 4) into the body(1).
· Tighten torque : 4.5kgf · m(32.5lb · ft)

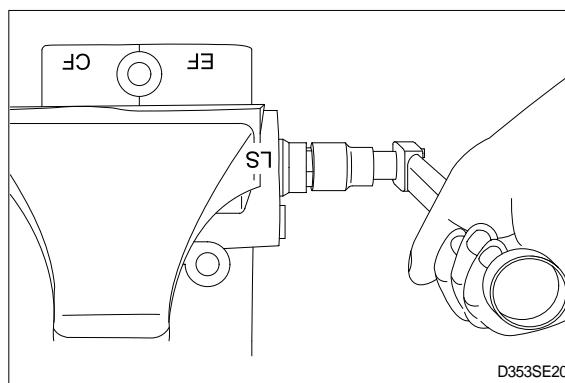

3. STEERING CYLINDER

1) STRUCTURE

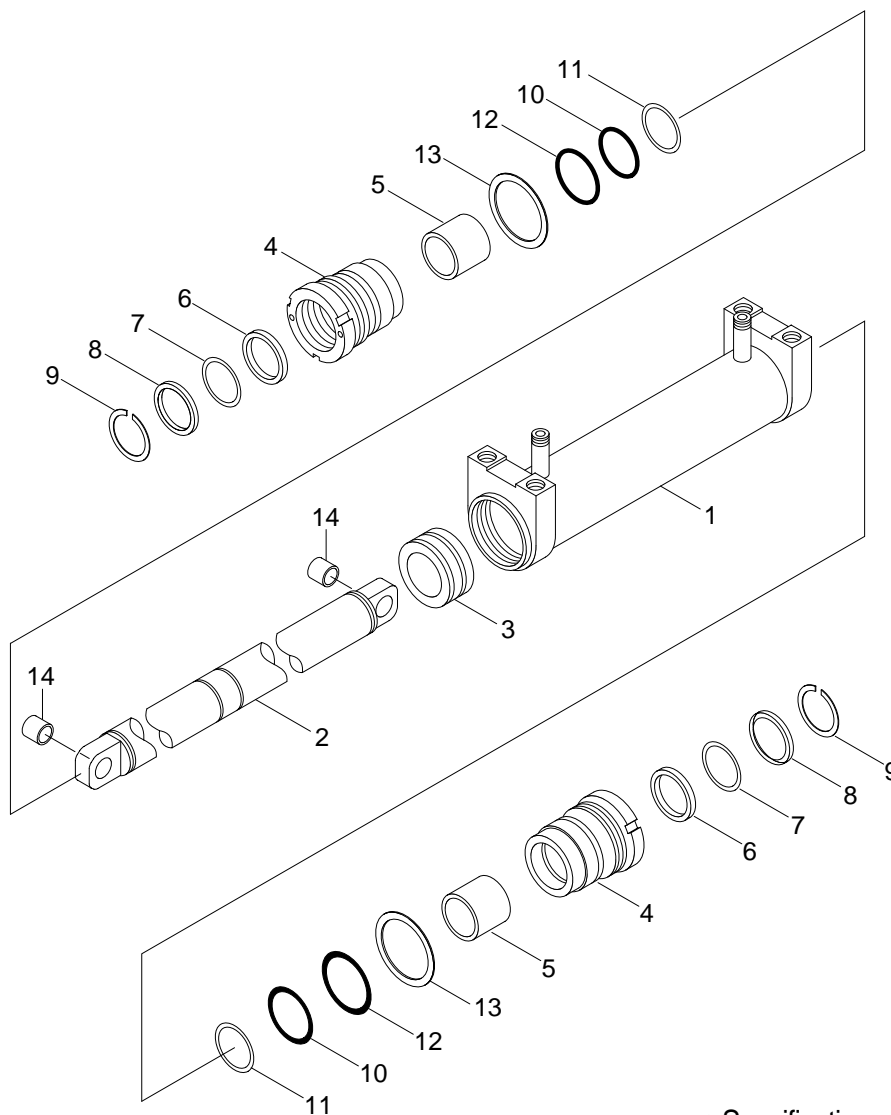

※ Specifications

- Cylinder bore : 80mm
- Outer diameter : 94mm
- Stroke(half) : 150mm
- Rod diameter : 55mm

D507SE21

- | | | | | | |
|---|-------------|----|--------------|----|--------------|
| 1 | Tube assy | 6 | Rod seal | 11 | Back up ring |
| 2 | Rod | 7 | Back up ring | 12 | O-ring |
| 3 | Piston seal | 8 | Dust wiper | 13 | Lock washer |
| 4 | Gland | 9 | Snap ring | 14 | Pin bushing |
| 5 | Bushing | 10 | O-ring | | |

2) DISASSEMBLY

※ Before disassembling steering cylinder, release oil in the cylinder first.

- (1) Put wooden blocks against the cylinder tube, then hold in & vice.
- (2) Remove the cover by hook a wrench in the notch of cylinder head and turn counter-clockwise.
- (3) Remove the cylinder rod and piston from the tube.
- (4) Check wear condition of the sealing parts(O-ring, oil seal, dust seal, U-packing, bush). If there are some damage, replace with new parts.

3) CHECK AND INSPECTION

mm(in)

Check item	Criteria		Remarks
	Standard size	Repair limit	
Clearance between piston & cylinder tube	0.05~0.25 (0.002~0.01)	0.4 (0.02)	Replace piston seal
Clearance between cylinder rod & bushing	0.05~0.18 (0.002~0.007)	0.3 (0.01)	Replace bushing
Seals, O-ring	Damage		Replace
Cylinder rod	Dents		Replace
Cylinder tube	Biting		Replace

4) ASSEMBLY

- (1) Install a new piston seal(3) around the groove on the piston.

※ Be careful not to scratch the seal too much during installation or it could not be seated properly.

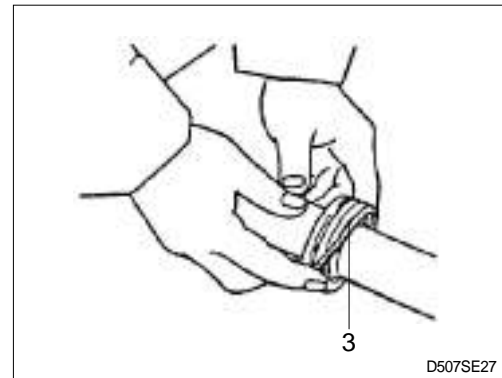

- (2) Install the rod seal(6) to the position in the gland(4) applying a slight coat with grease prior to install.

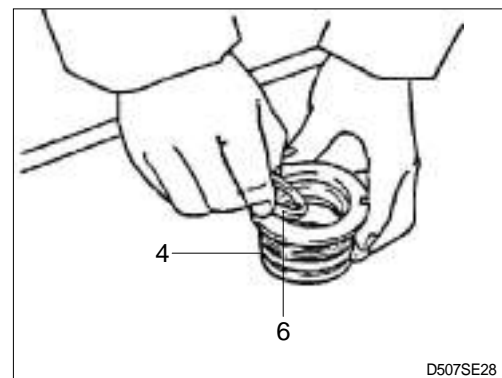

- (3) Install the dust wiper(8) to the gland(4) using a special installing tool. Coat the dust wiper with grease slightly before installing.
- (4) Using a special tool, install gland assembly into the cylinder tube(1).

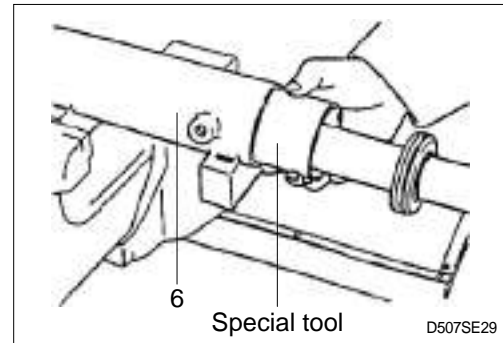

- (5) Using a hook spanner, install the gland(4) assembly, and tighten it with torque $60 \pm 6 \text{ kgf} \cdot \text{m}$ ($434 \pm 43 \text{ lbf} \cdot \text{ft}$).

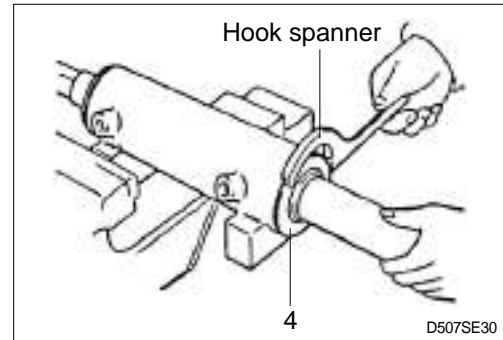

- (6) After the gland(4) assembly was installed to the cylinder tube(1), calk at the tube end into the groove on the gland to prevent screw loosening.
- ※ If it is needed to calk again, never calk on the same place.

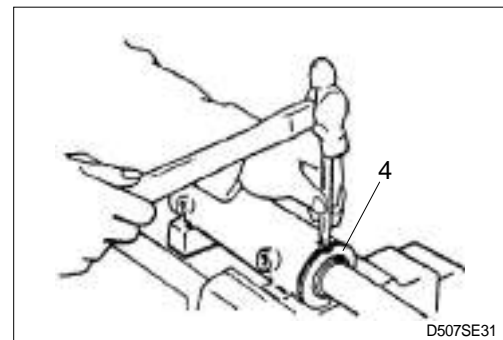

- (7) Move the piston rod back and forth several times for the full distance of its stroke. This helps to seat the ring and seals before applying full hydraulic pressure to the cylinder.
- (8) Install cylinder into trail axle.
- (9) While idling the engine with the rear wheels off the ground, operate the steering wheel left and right alternately.
- ※ Then, repeat the above operation at gradually increasing engine rpm. This releases air from the system and completes preparation for operation.
- (10) Stop the engine, lower the floating rear wheels, and check pump joints for oil leaks and looseness and retighten, them as required.

4. STEERING AXLE

1) STRUCTURE

※ Do not remove the stopper bolt unless necessary.

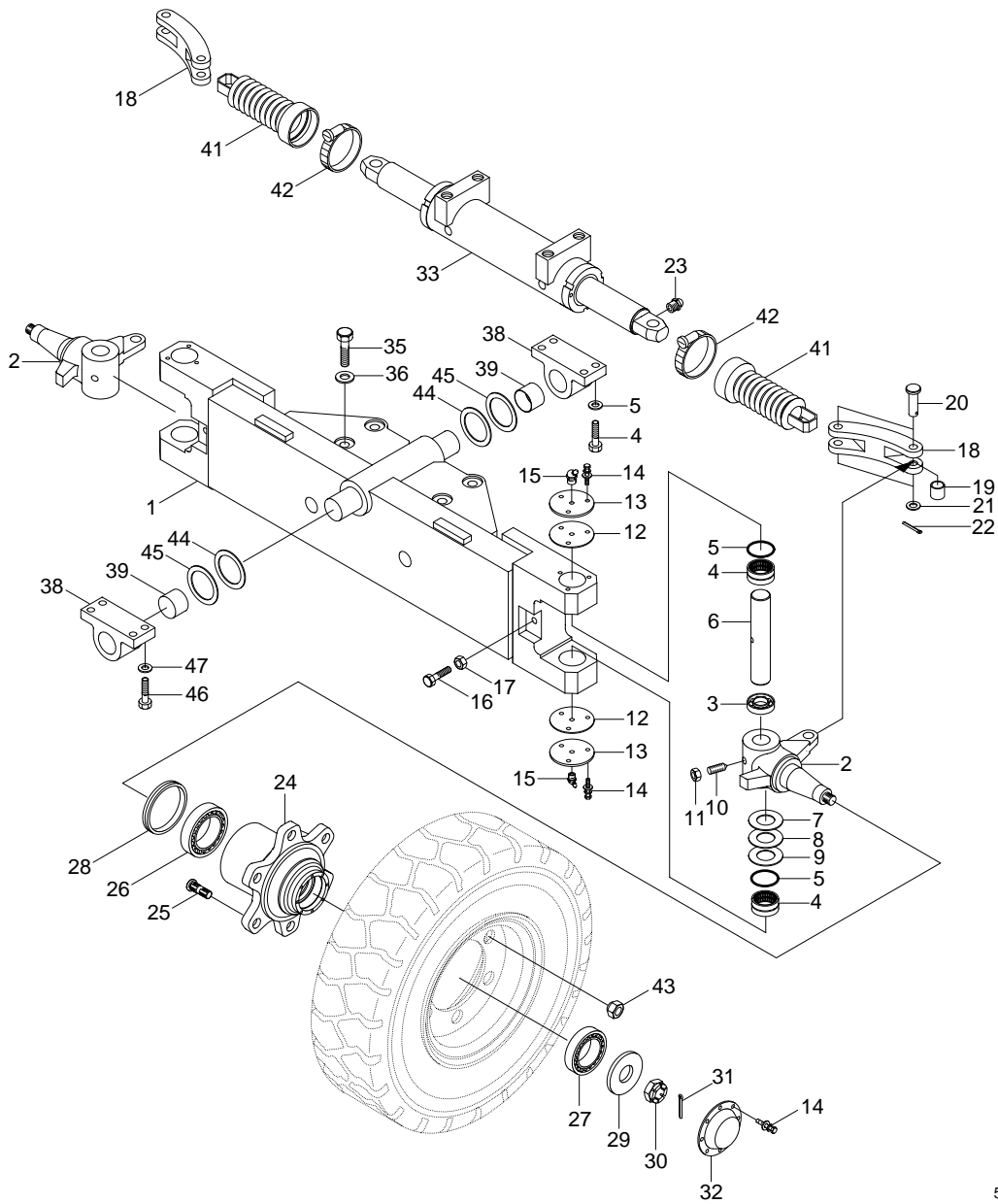

50DS7ESE24

1	Steering axle	12	Gasket	23	Grease nipple	35	Cover
2	Knuckle	13	Cover	24	Hub	36	Hexagon bolt
3	Thrust bearing	14	Bolt w/washer	25	Hub bolt	38	Support
4	Needle bearing	15	Grease nipple	26	Taper roller bearing	39	Bushing
5	Oil seal	16	Hexagon bolt	27	Taper roller bearing	41	Steer cylinder boot
6	King pin	17	Hexagon nut	28	Oil seal	42	Clamp
7	Thrust washer	18	Link	29	Special washer	43	Hub nut
8	Shim washer	19	Inner race bushing	30	Lock nut	44	Shim(1.0t)
9	Shim washer	20	Link pin	31	Split pin	45	Shim(0.5t)
10	Set screw	21	Special washer	32	Hub cap	46	Hexagon bolt
11	Hexagon nut	22	Split pin	33	Steering cylinder	47	Hardened washer

2) CHECK AND INSPECTION

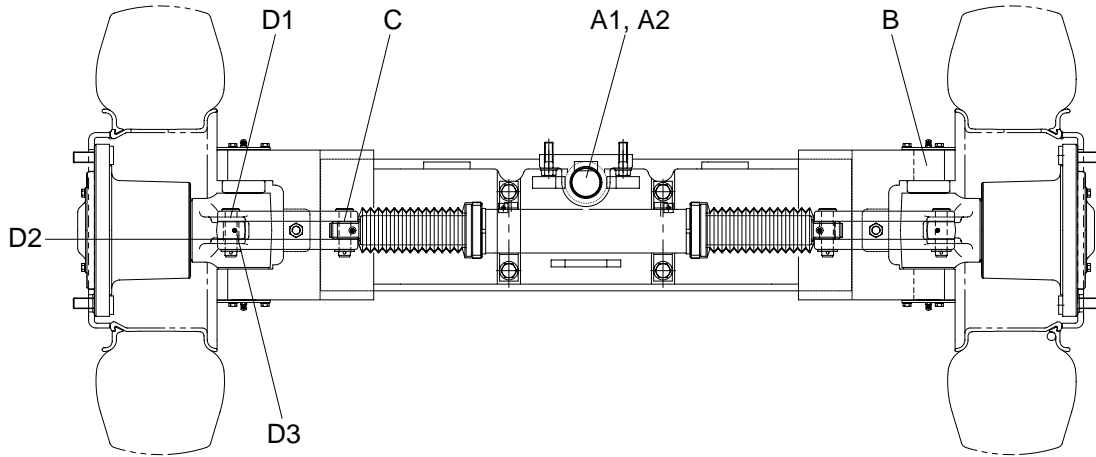

50DS7ESE25

unit : mm(in)

No.	Check item		Criteria		Remarks	
			Standard size	Repair limit		
A	Shaft	A1	OD of shaft	60(2.4)	59.5(2.3)	Replace
		A2	ID of bushing	60(2.4)	59.5(2.3)	
B	OD of king pin		50(2.0)	49.8(2.0)		
C	OD of steering cylinder pin		22(0.9)	21.9(0.9)		
D	Knuckle	D1	OD of pin	22(0.9)	21.9(0.9)	
		D2	Vertical play	-	0.2(0.008)	Adjust shim
		D3	ID of bushing	22(0.9)	22.5(0.9)	Replace

- OD : Outer diameter
- ID : Inner diameter

3) DISASSEMBLY

※ Servicing work on the knuckle part can be carried out without removing the axle assy from chassis.
The work can be done by jacking up the balance weight part of the truck.

- (1) Loosen the hub nut and take off the steering wheel tire.

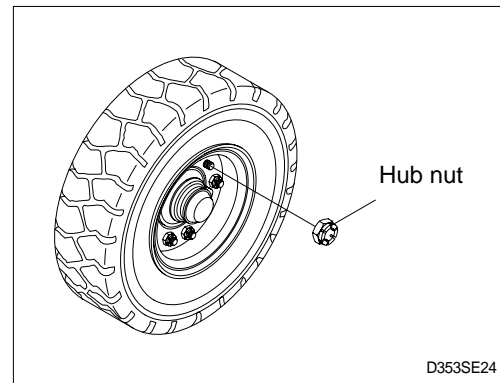

- (2) Remove Hub cap.
- (3) Pull out split pin and remove lock nut, washer.
- (4) Using the puller, take off the hub together with the roller bearing.
※ Be very careful because just before the hub comes off, tapered roller bearing will fall out.
- (5) After hub is removed take off the inner race of roller bearing.
- (6) Pull out oil seal.
※ Don't use same oil seal twice.
- (7) Repeat the same procedure for the other side.
Moreover, when disassembling is completed, part the lock nut in the knuckle to protect the threaded portion.

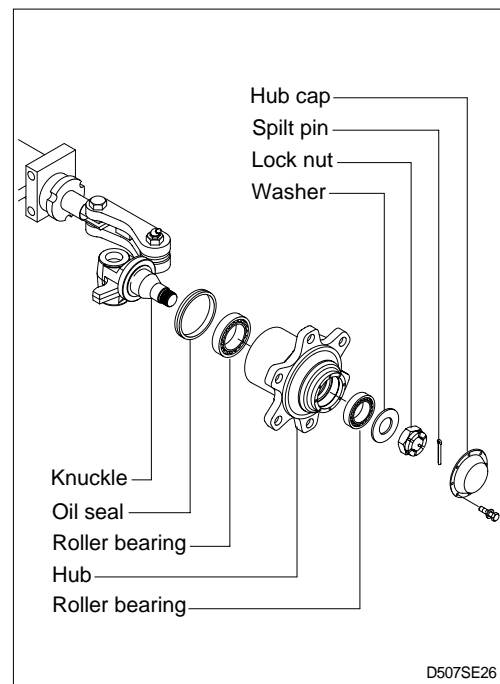

- (8) Loosen set screw(10) and nut(11).
- (9) Loosen with washer bolt(14) and remove cover (13), gasket(12). Remove grease nipple(15).
- (10) Push out the king pin(6) without damaging the knuckle arm(2).
- (11) At the same time the king pin is removed, pull out the oil seal(5).
- (12) If defect is observed in needle bearing(4), pull it out by using extractor.
- (13) Remove spilt pin(22), special washer(21) and link pin(20).

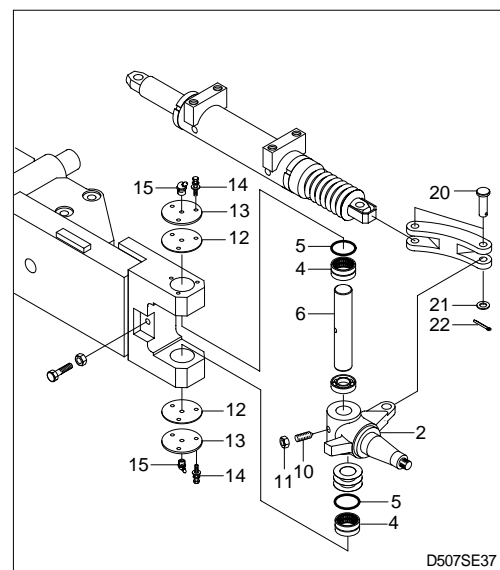

4) ASSEMBLY

※ In reassembling, have all parts washed, grease applied to lubricating parts, and all expendable items such as oil seal and spring washers replaced by new ones.

Perform the disassembly in reverse order.

- (1) Tighten the set screw(10) of king pin(6).
- (2) There is a notch in the middle of the king pin(6), make sure that this notch is on the set screw side.
- (3) Do not hammer to drive in needle bearing(4) because it will break.
Always use drive-in tool. In assembling the thrust bearing(3), be sure that the fixed ring of the bearing is placed in position facing the knuckle(2).

(4) Hub

- ① Mount oil seal(28) and inner race of tapered roller bearing(26) on the knuckle. The bearing should be well greased before assembling.
- ② Install the outer race of the bearing(27) in the wheel center and assemble to the knuckle.
- ③ Put washer(29) in place, tighten with nut(31) and locked with split pin(30). In locking with split pin, locate the hole for the split pin by turning the nut back 1/6 of a turn. Adjust the preload of bearing.
- ④ Mount the hub cap(32).
Bearing should be well greased before assembling.

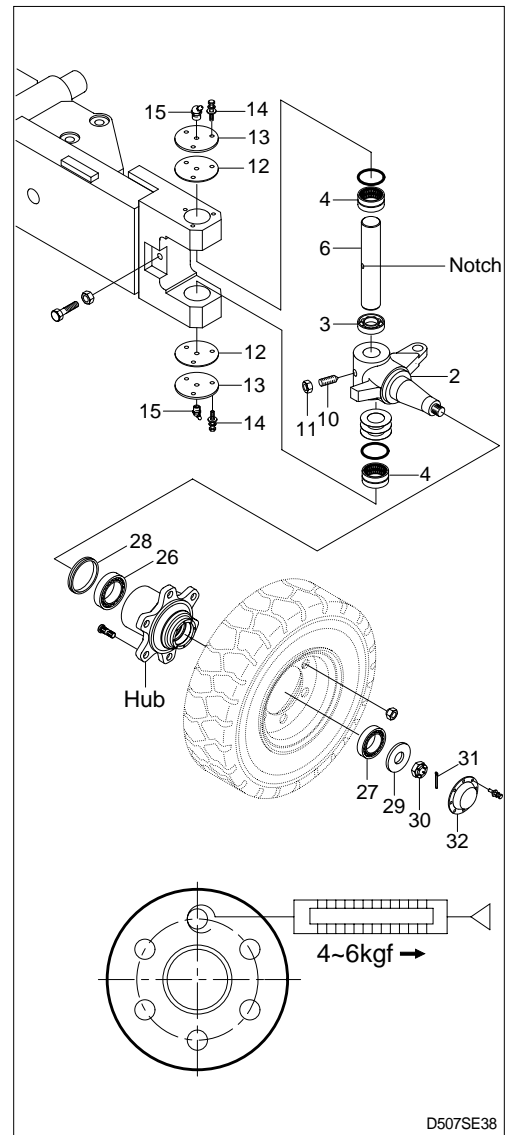

D507SE38

SECTION 6 HYDRAULIC SYSTEM

GROUP 1 STRUCTURE AND FUNCTION

1. HYDRAULIC CIRCUIT

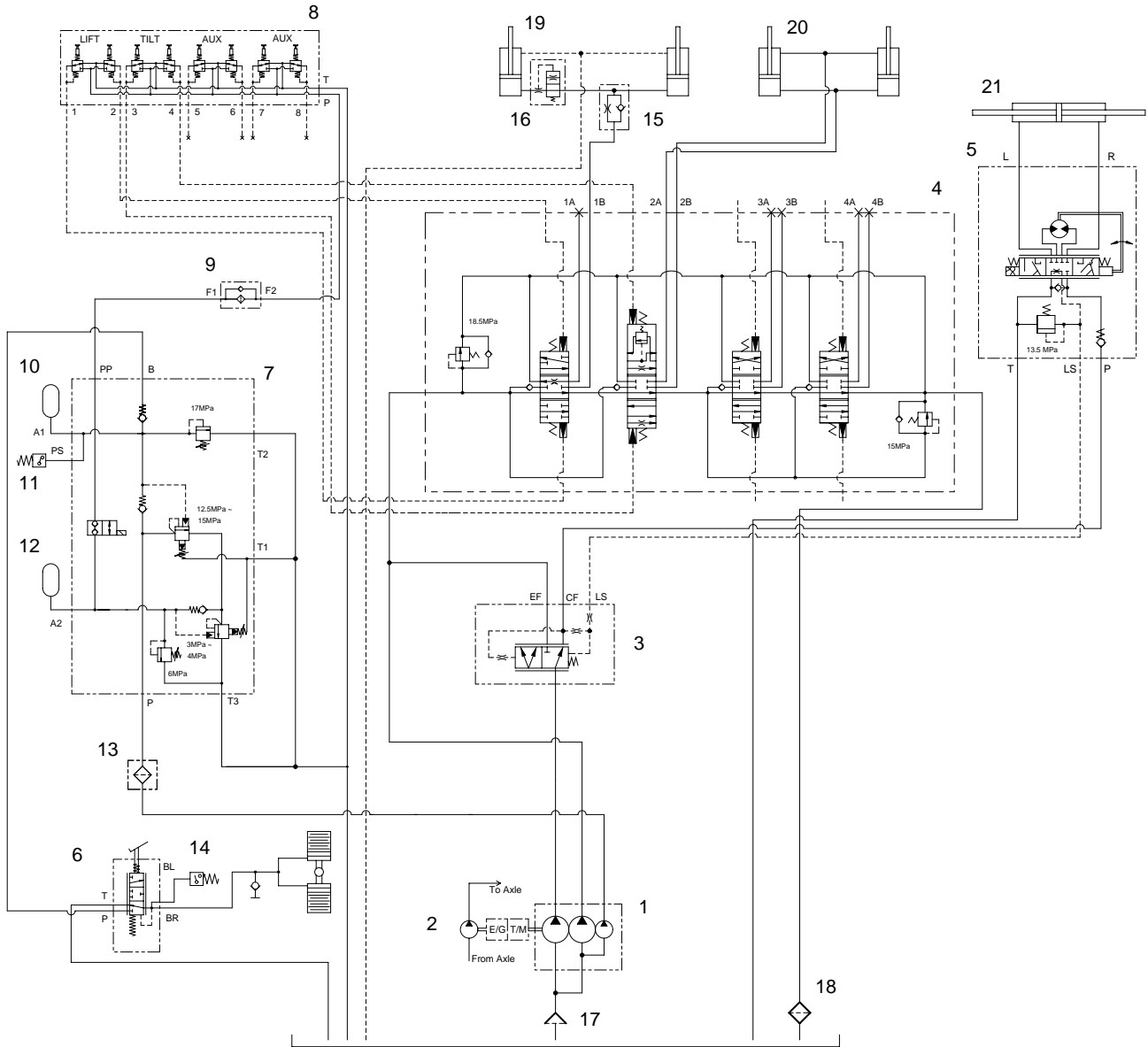

50D7EHS01

- | | | | | | |
|---|---------------------|----|----------------------|----|--------------------|
| 1 | Hydraulic gear pump | 8 | Remote control valve | 15 | Down control valve |
| 2 | Axle cooling pump | 9 | Suction filter | 16 | Down safety valve |
| 3 | Priority valve | 10 | Accumulator | 17 | Strainer |
| 4 | Main control valve | 11 | Pressure switch | 18 | Return filter |
| 5 | Steering unit | 12 | Accumulator | 19 | Lift cylinder |
| 6 | Brake valve | 13 | Line filter | 20 | Tilt cylinder |
| 7 | Cut-off valve | 14 | Pressure switch | 21 | Steering cylinder |

1) WHEN THE LIFT CONTROL LEVER IS IN THE LIFT POSITION

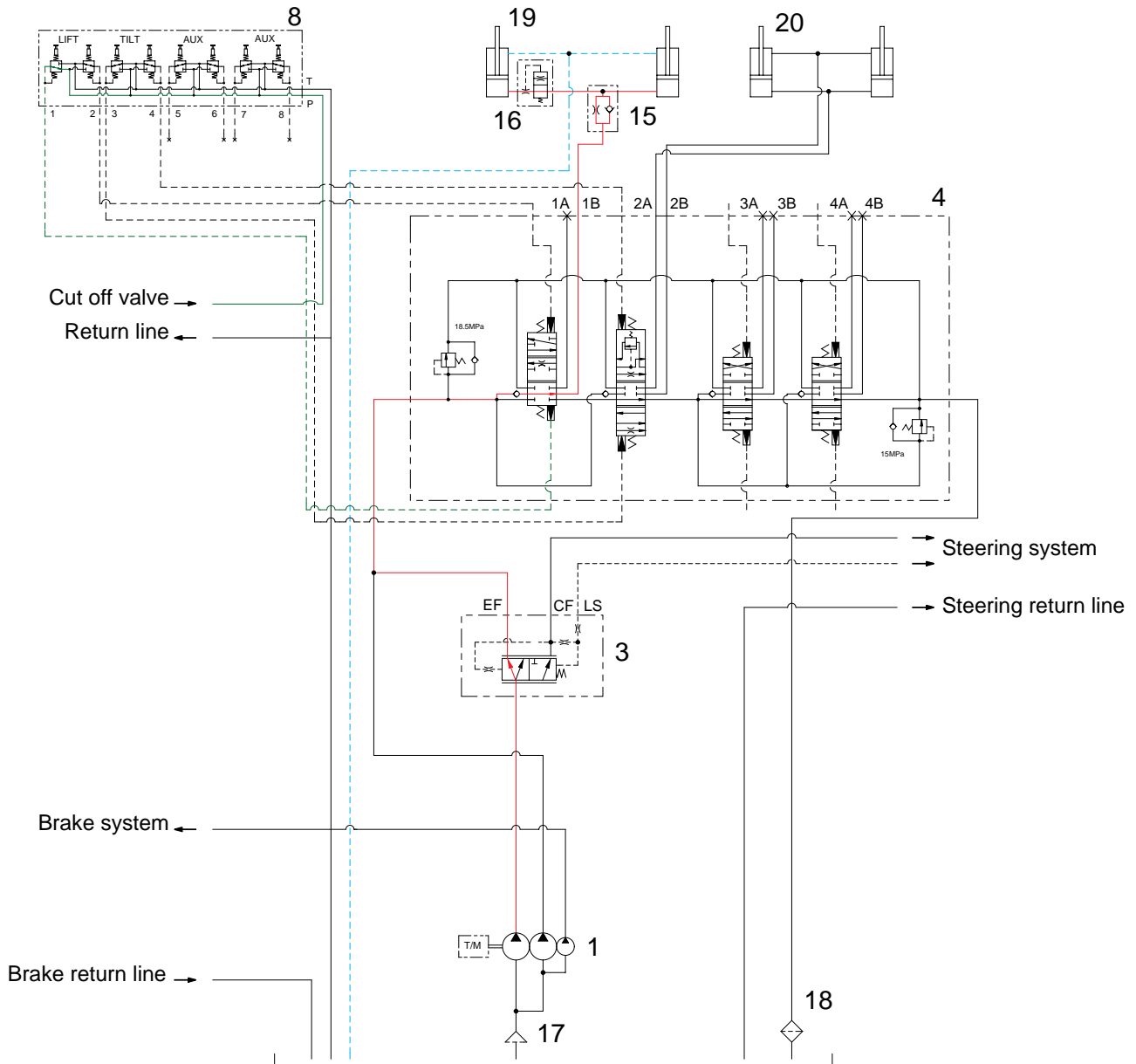

50D7EHS02

When the lift control lever is pulled back, the spool on the first block is moves to lift position. The oil from hydraulic gear pump(1) flows into main control valve(4) and then goes to the large chamber of lift cylinder(19) by pushing the load check valve of the spool. The oil from the small chamber of lift cylinder(19) returns to hydraulic oil tank at the same time. When this happens, the forks go up.

2) WHEN THE LIFT CONTROL LEVER IS IN THE LOWER POSITION

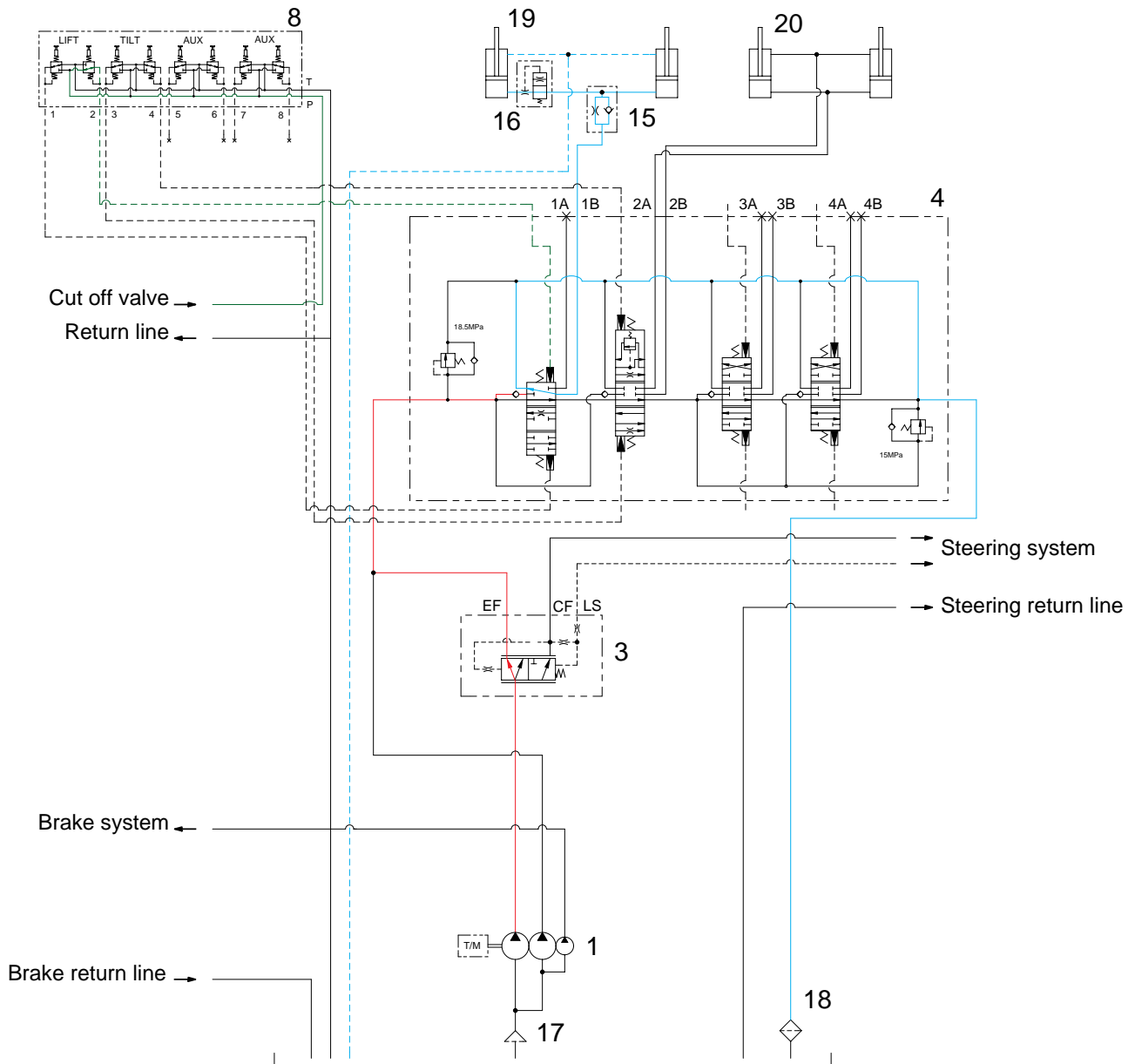

50D7EHS03

When the lift control is pushed forward, the spool on the first block is moved to lower position. The work port(1B) and the small chamber and the large chamber are connected to the return passage, so the lift will be lowered due to its own weight.

3) WHEN THE TILT CONTROL LEVER IS IN THE FORWARD POSITION

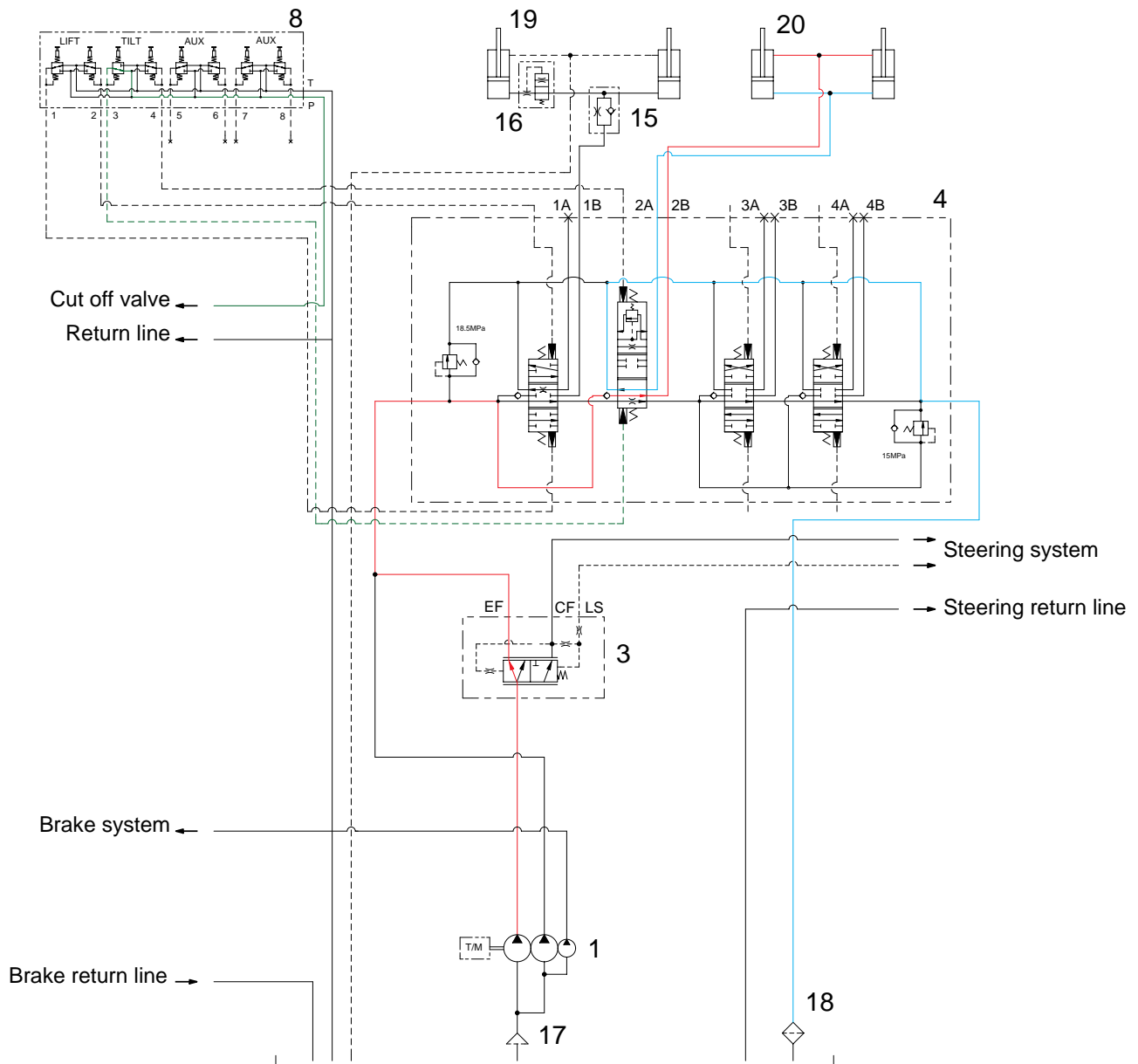

50D7EHS04

When the tilt control lever is pushed forward, the spool on the second block is moved to tilt forward position.

The oil from hydraulic gear pump(1) flows into main control valve(4) and then goes to the large chamber of tilt cylinder(20) by pushing the load check valve of the spool.

The oil at the small chamber of tilt cylinder(20) returns to hydraulic tank at the same time.

When this happens, the mast tilt forward.

4) WHEN THE TILT CONTROL LEVER IS IN THE BACKWARD POSITION

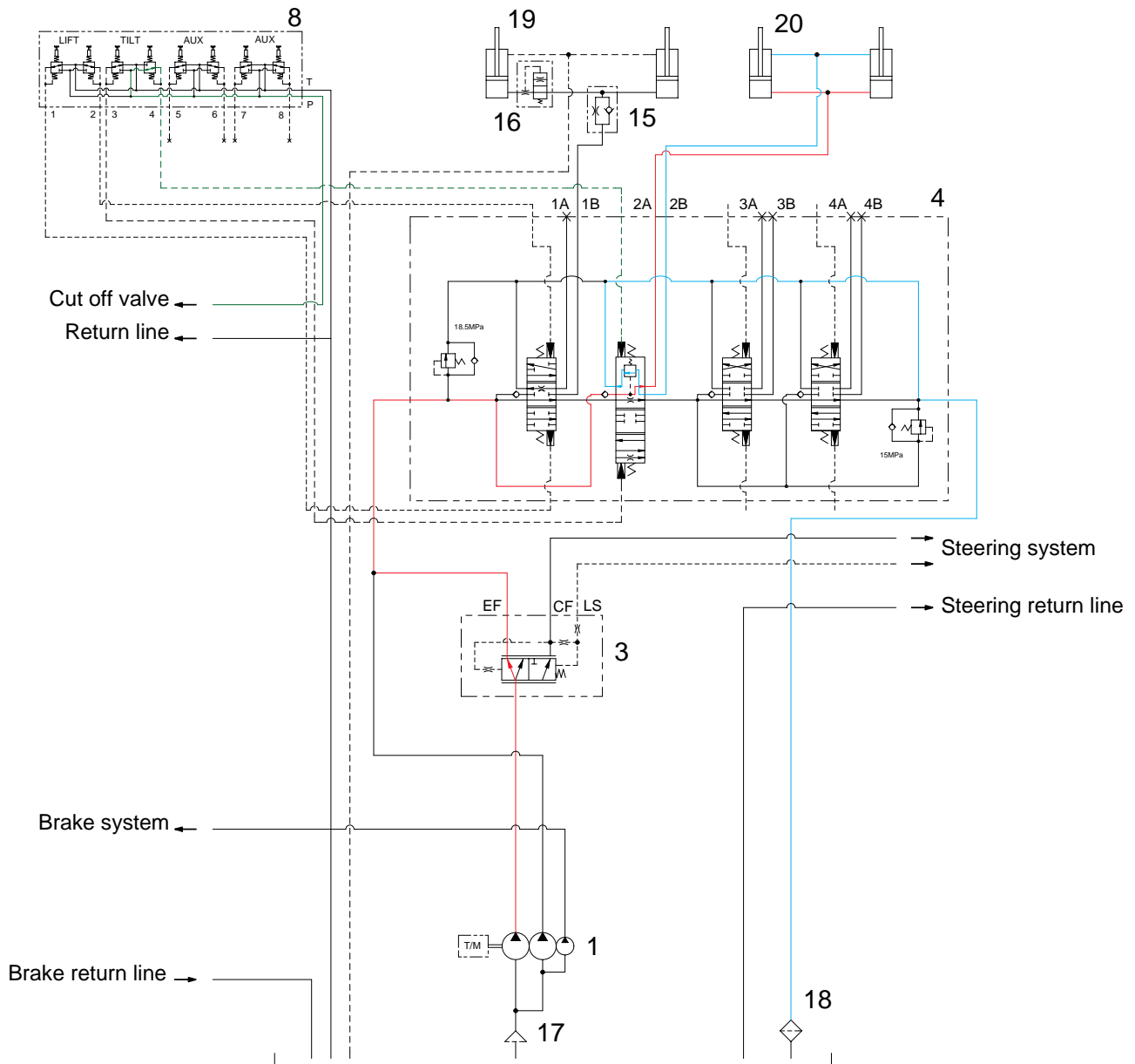

50D7EHS05

When the tilt control lever is pulled back, the spool on the second block is moved to tilt backward position.

The oil from hydraulic gear pump(1) flows into main control valve(4) and then goes to the small chamber of tilt cylinder(20) by pushing the load check valve of spool.

The oil at the large chamber of tilt cylinder(20) returns to hydraulic tank at the same time.

When this happens, the mast tilt backward.

2. HYDRAULIC GEAR PUMP

1) STRUCTURE

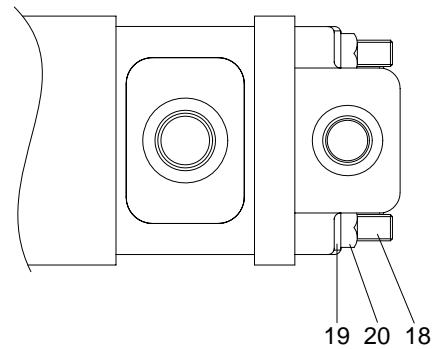
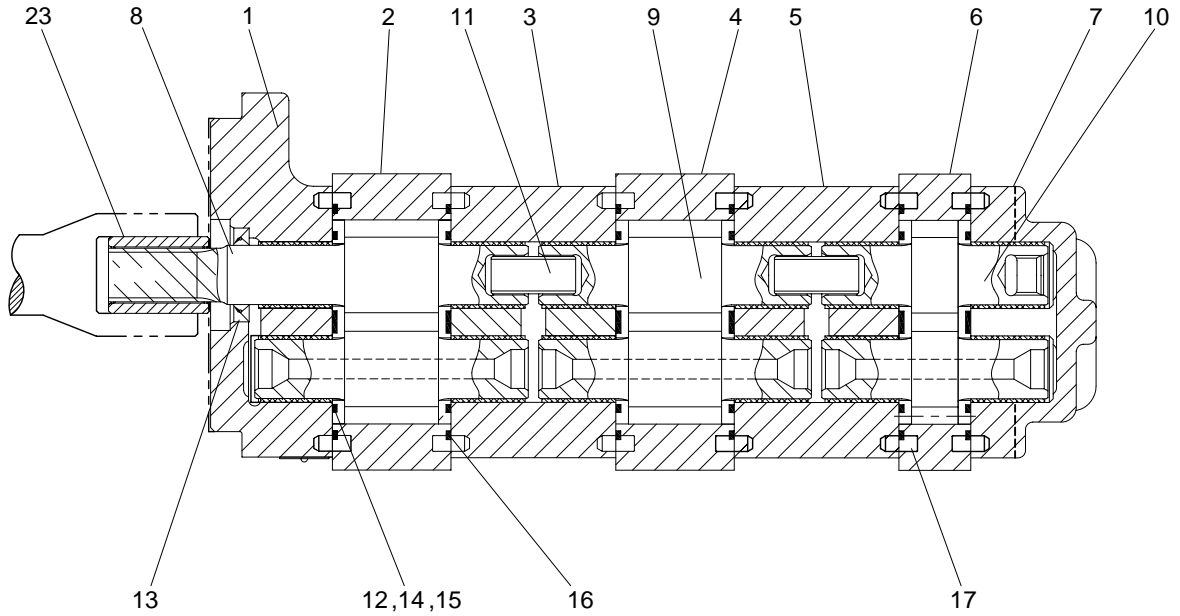

50D7EHS06

1	Cover	8	Shaft gear	15	Seal
2	Gear housing	9	Drive gear	16	Seal
3	Carrier	10	Gear set	17	Dowel pin
4	Gear housing	11	Shaft	18	Stud bolt
5	Carrier	12	Thrust plate	19	Washer
6	Gear housing	13	Seal	20	Hex-nut
7	Cover	14	Seal	23	Shaft

3. MAIN CONTROL VALVE

1) STRUCTURE(5 Spool)

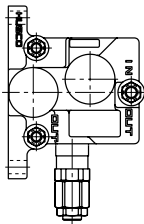
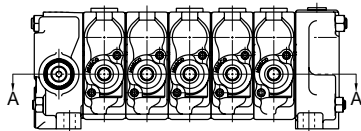
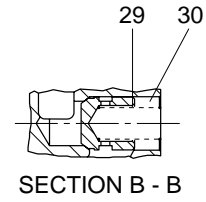
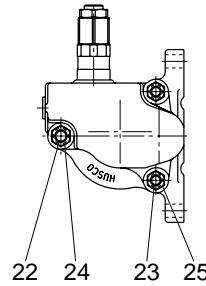
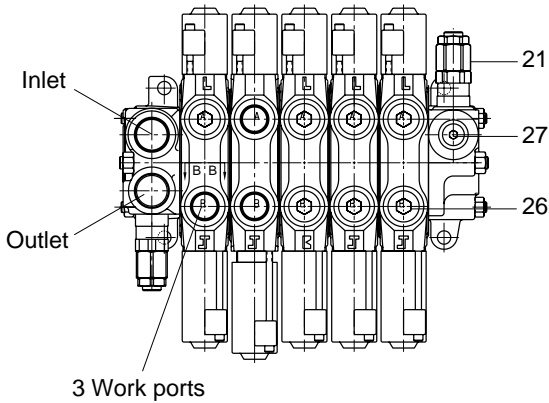

20

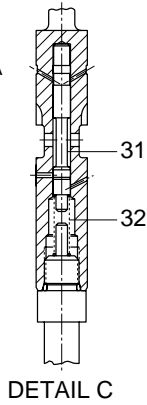

DETAIL C

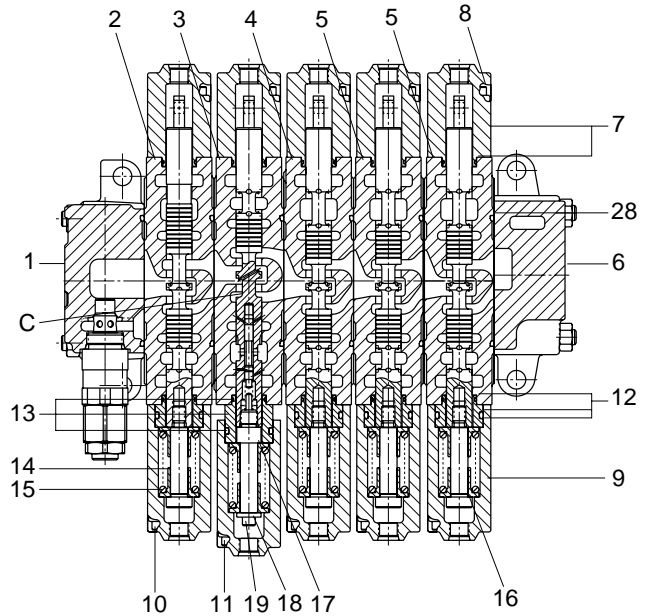

SECTION A - A

Port name	Size
Inlet port	1-5/16-12UNF
Outlet port	1-5/16-12UNF
Gauge port	PF1/4
Work port	1-1/16-12UNF

50D7EHS07

- | | | | | | |
|----|--------------------------|----|------------------------|----|-------------|
| 1 | Inlet section assy | 12 | Retainer | 23 | Tie rod |
| 2 | Spool section assy(Lift) | 13 | Retainer | 24 | Special nut |
| 3 | Spool section assy(Tilt) | 14 | Spring set | 25 | Special nut |
| 4 | Spool section assy(Aux) | 15 | Spring | 26 | Plug |
| 5 | Spool section assy(Aux) | 16 | Screw | 27 | Plug |
| 6 | Outlet section assy | 17 | Spool end | 28 | O-ring |
| 7 | Spool cap | 18 | Washer | 29 | Poppet |
| 8 | Cap screw | 19 | Cap screw | 30 | Spring |
| 9 | Spool cap | 20 | Main relief valve assy | 31 | Piston |
| 10 | Cap screw | 21 | Port relief valve assy | 32 | Spring |
| 11 | Cap screw | 22 | Tie rod | | |

2) LIFT SECTION OPERATION

(1) Lift position

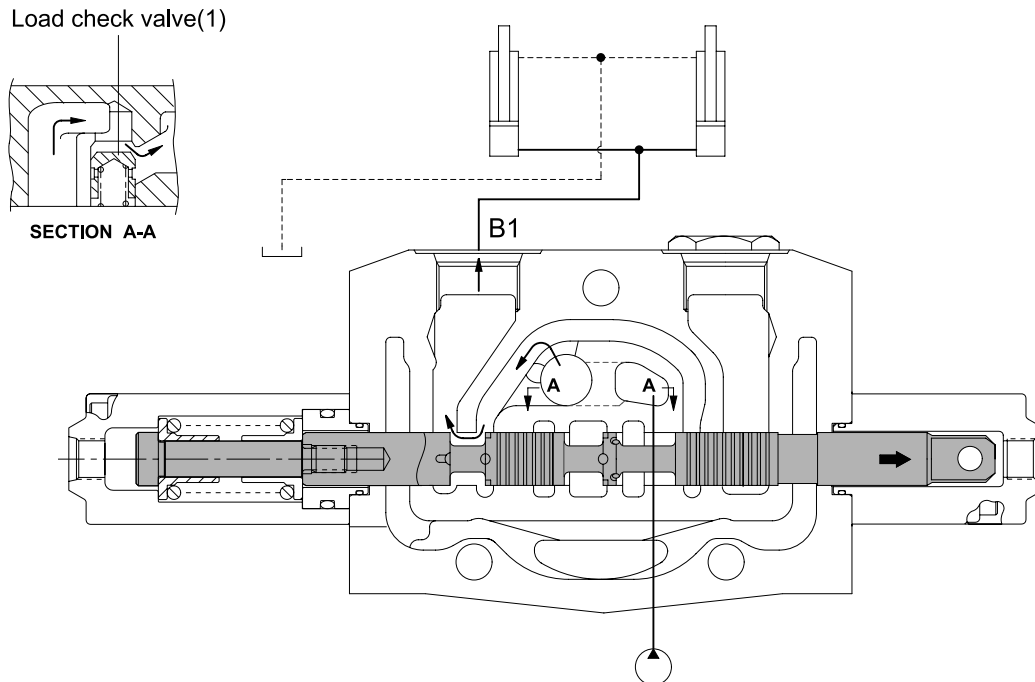

50D7EHS08

When the lift control lever is pulled back, the spool moves to the right and the neutral passage is closed.

The oil supplied from the pump pushes up the load check valve(1) and flow into lift cylinder port(B1). The pump pressure reaches proportionally the load of cylinder and fine control finished by shut off of the neutral passage.

The return oil from cylinder flows into the tank.

(2) Lower position

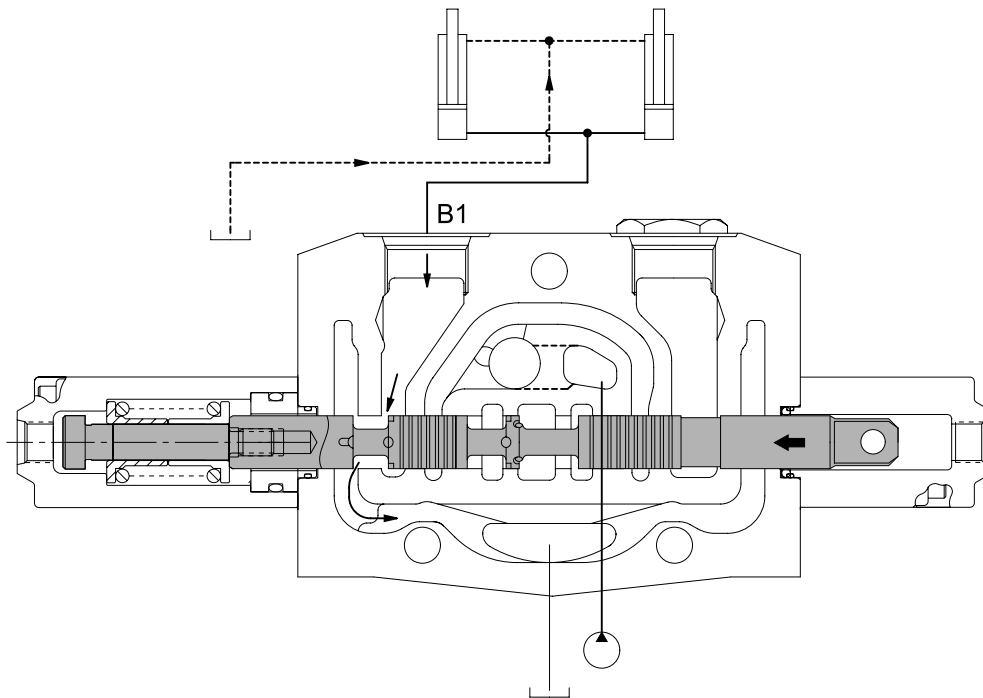

50D7EHS09

When the lift control lever is pushed forward, the spool moves to the left and the neutral passage is closed.

The spool moves to the lift lower position, opening up the neutral passage to tank and (B1)→T.

In lift lower position the fork drops due to its own weight.

3) TILT SECTION OPERATION

(1) Tilt forward position

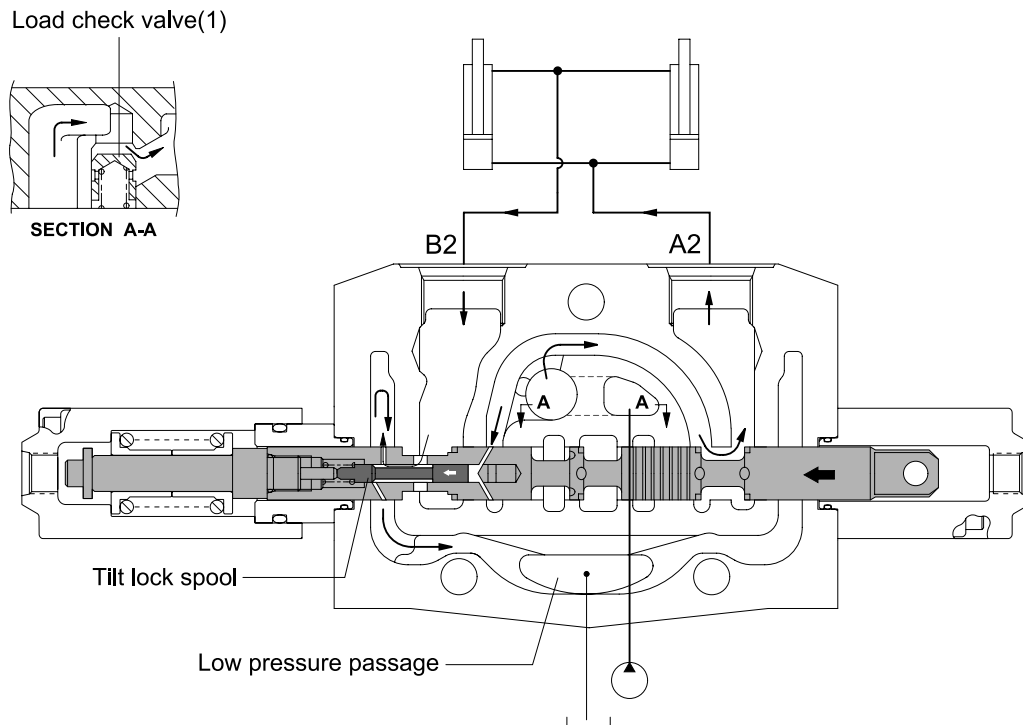

50D7EHS10

When the tilt control lever is pushed forward, the spool moves to the left and the neutral passage is closed.

The oil supplied from the pump pushes up the load check valve(1) and flow into tilt cylinder port(A2). The pump pressure reaches proportionally the load of cylinders and fine control finished by closing the neutral passage.

The return oil from cylinder port(B2) flows into the tank through the hole of the tilt lock spool.

(2) Tilt backward position

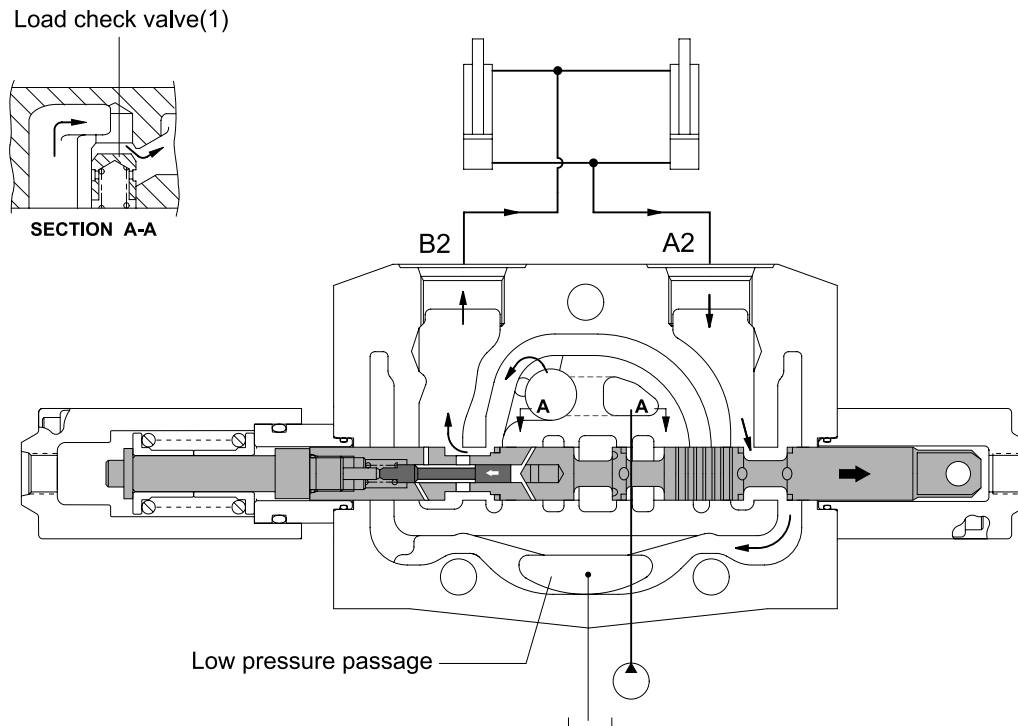

50D7EHS11

When the tilt control lever is pulled back, the spool moves to the right and the neutral passage is closed.

The oil supplied from the pump pushes up the load check valve(1) and flows into tilt cylinder port(B2). The pump pressure reaches proportionally the load of cylinder and fine control finished by shut off of the neutral passage.

The return oil from cylinder port(A2) flows into the tank via the low pressure passage.

4) MAIN RELIEF VALVE

(1) Pressure setting

A good pressure gauge must be installed in the line which is in communication with the work port relief. A load must be applied in a manner to reach the set pressure of the relief unit.

Procedure

- ① Loosen lock nut.
- ② Set adjusting nut to desired pressure setting.
- ③ If desired pressure setting cannot be achieved, add or remove shims as required.
- ④ Tighten lock nut.
- ⑤ Retest in similar manner as above.

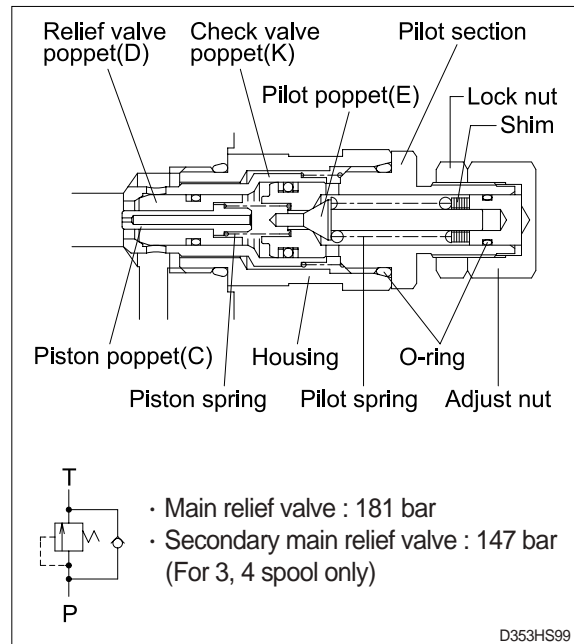

(2) Function

① As work port relief

The relief valve is in communication between the high pressure port HP and low pressure LP. Oil is admitted through the hole in poppet C and because of the differential area between diameters A and B relief valve poppet D and check valve poppet K are tightly seated as shown.

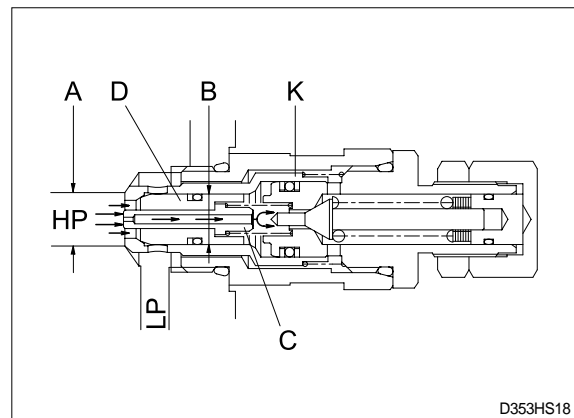

The oil pressure in the high pressure port HP has reached the setting of the pilot poppet spring force and unseats the pilot poppet E and oil flows around the poppet through the cross drilled holes and to the low pressure area LP.

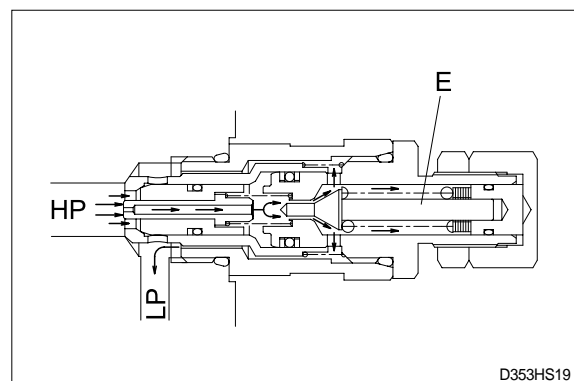

The loss of oil behind poppet C, effected by the opening of pilot poppet E, causes poppet C to move back and seat against pilot poppet E. This shuts off the oil flow to the area behind relief valve poppet D, and causes a low pressure area internally.

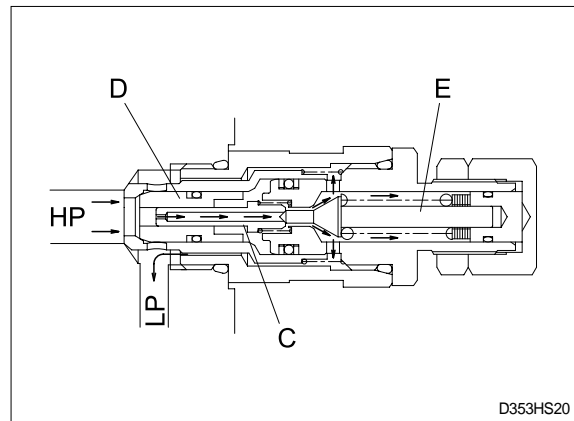

The imbalance of pressure on the inside as compared to that of the high pressure port HP, forces the relief valve poppet D to open and relieve the oil directly to the low pressure chamber LP in the valve.

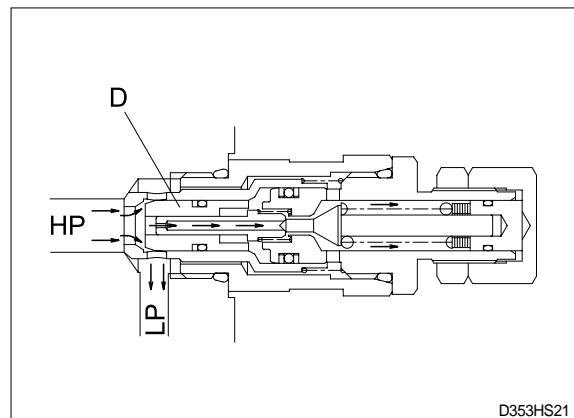

② As anti void

The anti-void unit supplies oil to the high pressure port HP when cavitation has occurred. A lower pressure exists in the port HP compared to the low pressure chamber LP. The difference between the effective area of diameter A and G causes imbalance of the check valve poppet K which unseats, thus allowing oil from the low pressure chamber LP to enter the port HP and fill the void.

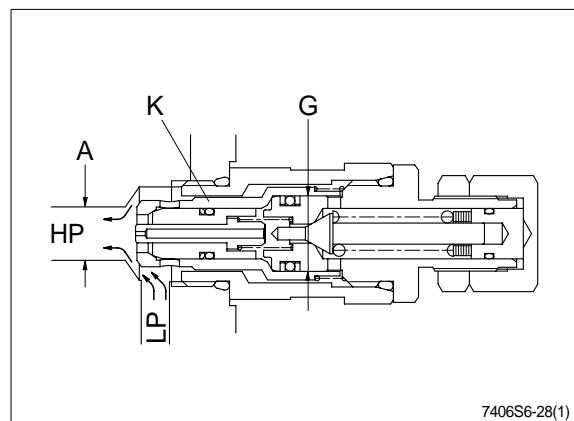

4. REMOTE CONTROL VALVE

1) STRUCTURE

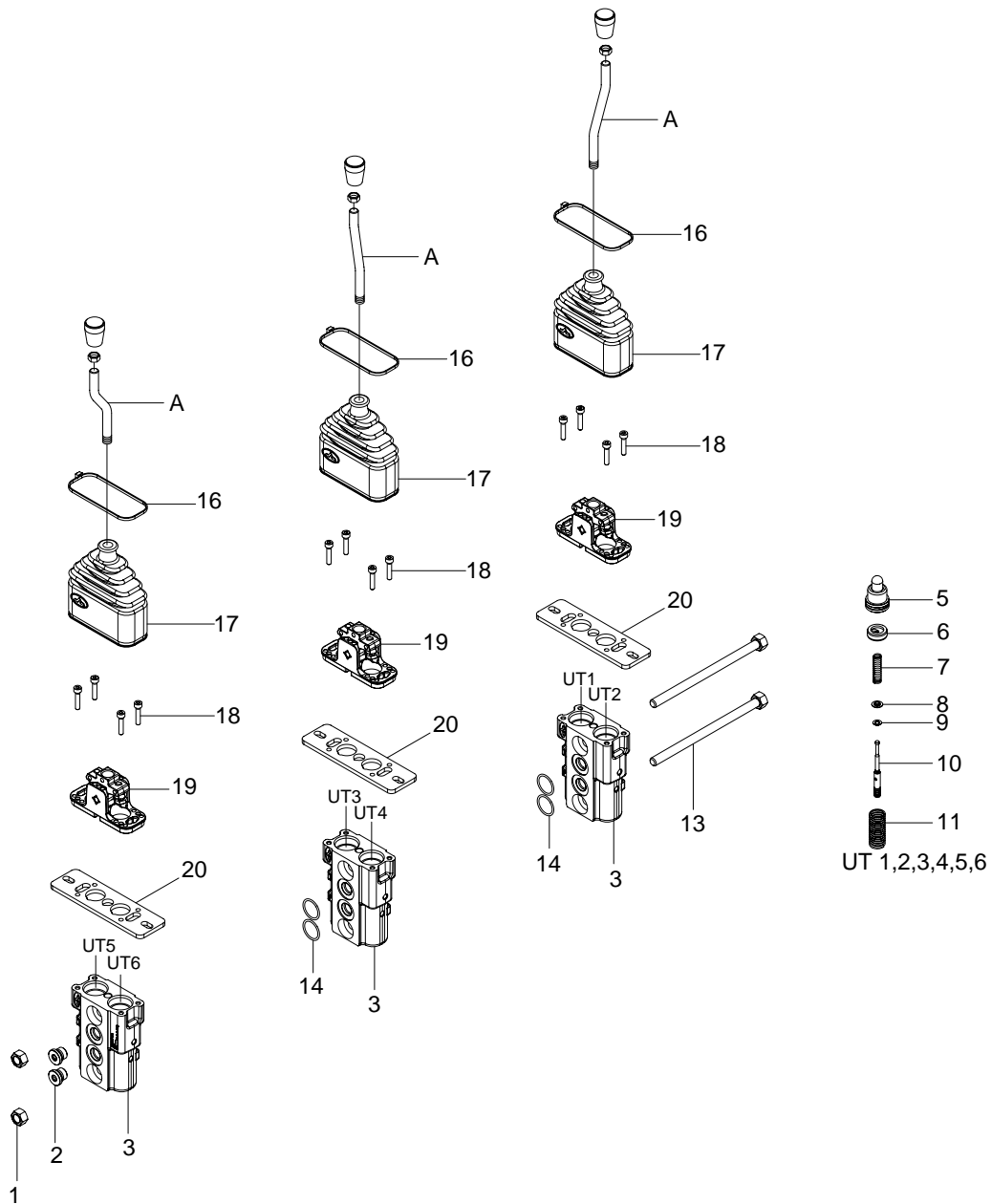

A	Lever	7	Metering spring	14	O-ring
1	Nut	8	Seeger ring	15	Kit 3
2	Plug	9	Seeger ring	16	Clamp
3	Body	10	Docking rod	17	Rubber bellows
4	Kit 1	11	Spring	18	Screw
5	Plunger kit	12	Kit 2	19	Support kit
6	Spring guide	13	Tie rod with nut	20	Flange

100D7RCV00

2) OPERATION

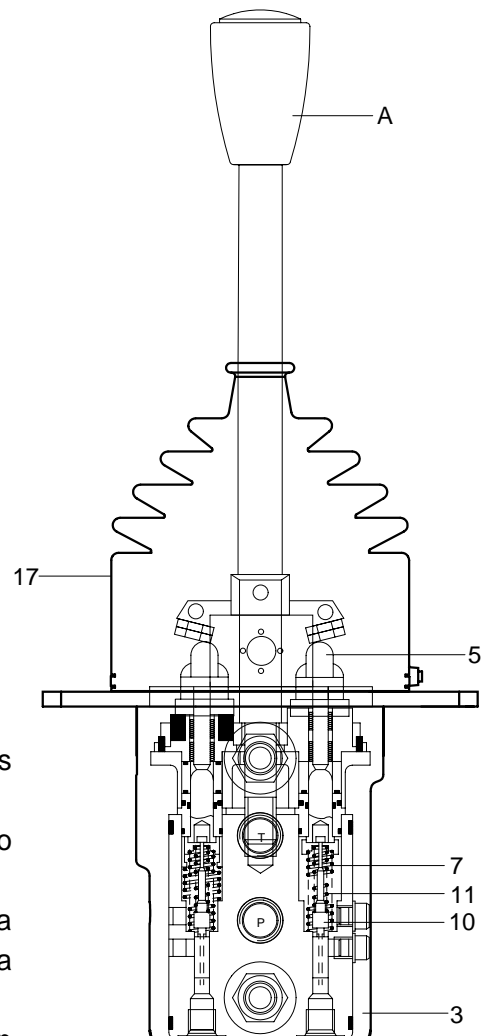
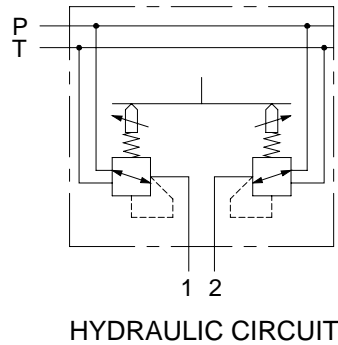

100D7RCV01

(1) Hydraulic functional principle

Pilot devices with end position locks operate as direct operated pressure reducing valves.

They basically comprise of control lever(A), two pressure reducing valves, body(3) and locks.

Each pressure reducing valve comprises of a plunger kit(5), a metering spring(7) and a spring(11).

At rest, control lever(A) is held in its neutral position by return springs(11). Ports(1, 2) are connected to tank port T.

When control lever(A) is deflected, plunger kit(5) is pressed against return spring(11) and metering spring(7).

Metering spring(7) initially moves docking rod(10) downwards and closes the connection between the relevant port and tank port T. At the same time the relevant port is connected to port P. The control phase starts as soon as docking rod(10) finds its balance between the force from metering spring(7) and the force, which results from the hydraulic pressure in the relevant port(ports 1, 2).

Due to the interaction between docking rod(10) and metering spring(7) the pressure in the relevant port is proportional to the stroke of plunger(5) and hence to the position of control lever(A).

This pressure control which is dependent on the position of the control lever and the characteristics of the control spring permits the proportional hydraulic control of the main directional valves and high response valves for hydraulic pumps.

A rubber bellows(17) protects the mechanical components in the housing from contamination.

5. LIFT CYLINDER

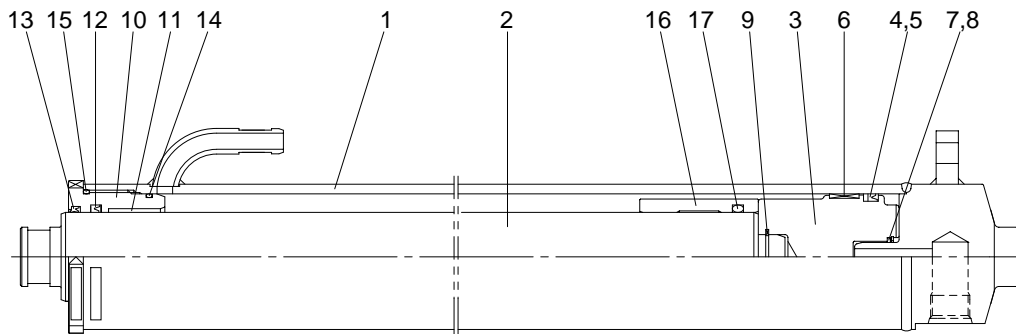

D507HS12

- | | | | | | |
|---|--------------|----|----------------|----|------------|
| 1 | Tube assy | 7 | Cushion seal | 13 | Dust wiper |
| 2 | Rod | 8 | Retaining ring | 14 | O-ring |
| 3 | Piston | 9 | Retaining ring | 15 | O-ring |
| 4 | Piston seal | 10 | Gland | 16 | Spacer |
| 5 | Back up ring | 11 | Du bushing | 17 | O-ring |
| 6 | Wear ring | 12 | Rod seal | | |

6. TILT CYLINDER

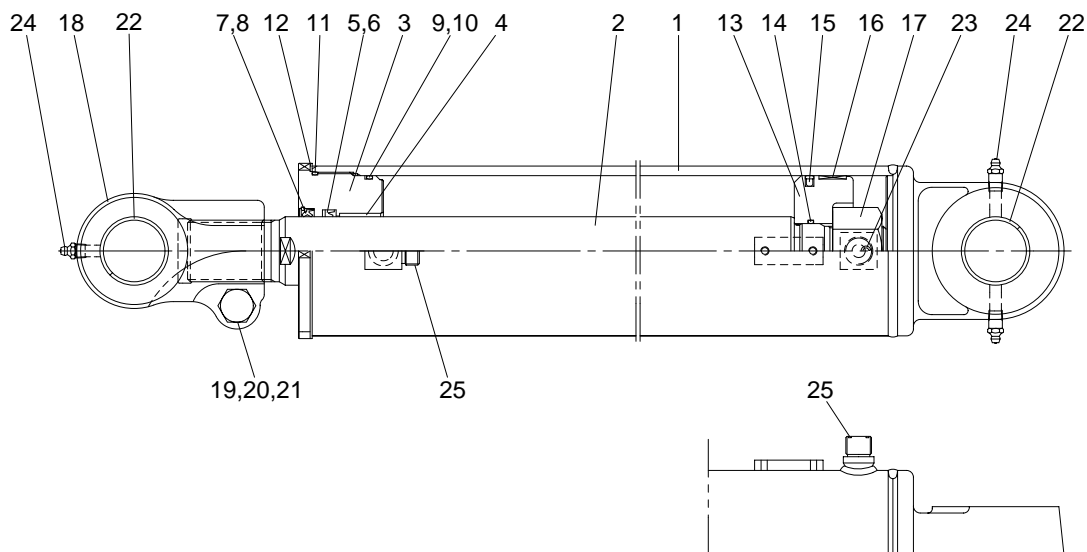

50D7EHS13

- | | | | | | |
|---|--------------|----|--------------|----|---------------|
| 1 | Tube assy | 10 | Back up ring | 19 | Hexagon bolt |
| 2 | Rod | 11 | Lock washer | 20 | Hexagon nut |
| 3 | Gland | 12 | O-ring | 21 | Spring washer |
| 4 | DU bushing | 13 | Piston | 22 | DU bushing |
| 5 | Rod seal | 14 | O-ring | 23 | Spring-pin |
| 6 | Back up ring | 15 | Piston seal | 24 | Grease nipple |
| 7 | Dust wiper | 16 | Wear ring | 25 | O-ring |
| 8 | Snap ring | 17 | Nylon nut | | |
| 9 | O-ring | 18 | Rod eye | | |

GROUP 2 OPERATIONAL CHECKS AND TROUBLESHOOTING

1. OPERATIONAL CHECKS

1) CHECK ITEM

- (1) Check visually for deformation, cracks or damage of rod.
- (2) Load maximum load, set mast vertical and raise 1m from ground. Wait for 10 minutes and measure hydraulic drift (amount forks move down and amount mast tilts forward).

· Hydraulic drift

- Down (Downward movement of forks)
: Within 100mm (3.9in)
- Forward (Extension of tilt cylinder)
: Within 5°

If the hydraulic drift is more than the specified value, replace the control valve or cylinder packing.

- (3) Check that clearance between tilt cylinder bushing and mounting pin is within standard range.

	mm (in)
Standard	Under 0.6 (0.02)

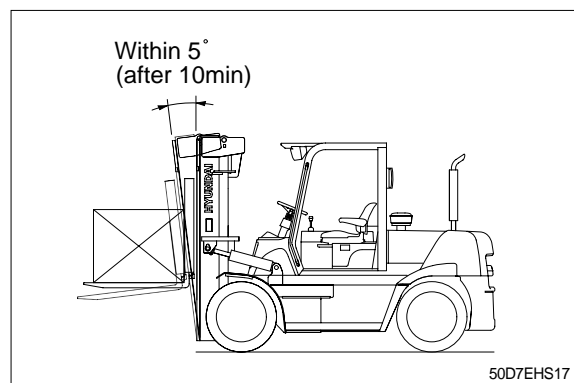
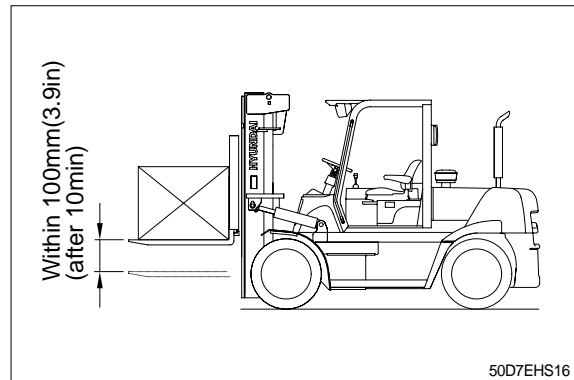

2) HYDRAULIC OIL

- (1) Using dipstick, measure oil level, and oil if necessary.
- (2) When changing hydraulic oil, clean suction strainer (screwed into outlet port pipe) and line filter (screwed into inlet pipe).

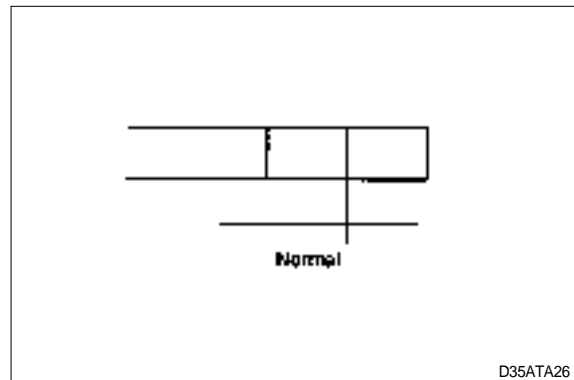

3) CONTROL VALVE

- (1) Raise forks to maximum height and measure oil pressure.

Check that oil pressure is 188kgf/cm².
(2675psi)

2. TROUBLESHOOTING

1) SYSTEM

Problem	cause	Remedy
Large fork lowering speed.	<ul style="list-style-type: none"> Seal inside control valve defective. Oil leaks from joint or hose. Seal inside cylinder defective. 	<ul style="list-style-type: none"> Replace spool or valve body. Replace. Replace packing.
Large spontaneous tilt of mast.	<ul style="list-style-type: none"> Tilting backward : Check valve defective. Tilting forward : tilt lock valve defective. Oil leaks from joint or hose. Seal inside cylinder defective. 	<ul style="list-style-type: none"> Clean or replace. Clean or replace. Replace. Replace seal.
Slow fork lifting or slow mast tilting.	<ul style="list-style-type: none"> Lack of hydraulic oil. Hydraulic oil mixed with air. Oil leaks from joint or hose. Excessive restriction of oil flow on pump suction side. Relief valve fails to keep specified pressure. Poor sealing inside cylinder. High hydraulic oil viscosity. Mast fails to move smoothly. Oil leaks from lift control valve spool. Oil leaks from tilt control valve spool. 	<ul style="list-style-type: none"> Add oil. Bleed air. Replace. Clean filter. Adjust relief valve. Replace packing. Change to SAE10W, class CD engine oil. Adjust roll to rail clearance. Replace spool or valve body. Replace spool or valve body.
Hydraulic system makes abnormal sounds.	<ul style="list-style-type: none"> Excessive restriction of oil flow pump suction side. Gear or bearing in hydraulic pump defective. 	<ul style="list-style-type: none"> Clean filter. Replace gear or bearing.
Control valve lever is locked	<ul style="list-style-type: none"> Foreign matter jammed between spool and valve body. Valve body defective. 	<ul style="list-style-type: none"> Clean. Tighten body mounting bolts uniformly.
High oil temperature.	<ul style="list-style-type: none"> Lack of hydraulic oil. High oil viscosity. Oil filter clogged. 	<ul style="list-style-type: none"> Add oil. Change to SAE10W, class CD engine oil. Clean filter.

2) HYDRAULIC GEAR PUMP

Problem	Cause	Remedy
Pump does not develop full pressure.	<ul style="list-style-type: none"> • System relief valve set too low or leaking. • Oil viscosity too low. • Pump is worn out. 	<ul style="list-style-type: none"> • Check system relief valve for proper setting. • Change to proper viscosity oil. • Repair or replace pump.
Pump will not pump oil.	<ul style="list-style-type: none"> • Reservoir low or empty. • Suction strainer clogged. 	<ul style="list-style-type: none"> • Fill reservoir to proper level. • Clean suction strainer.
Noisy pump caused by cavitation.	<ul style="list-style-type: none"> • Oil too thick. • Oil filter plugged. • Suction line plugged or too small. 	<ul style="list-style-type: none"> • Change to proper viscosity. • Clean filters. • Clean line and check for proper size.
Oil heating.	<ul style="list-style-type: none"> • Oil supply low. • Contaminated oil. • Setting of relief valve too high or too low. • Oil viscosity too low. 	<ul style="list-style-type: none"> • Fill reservoir to proper level. • Drain reservoir and refill with clean oil. • Set to correct pressure. • Drain reservoir and fill with proper viscosity.
Foaming oil.	<ul style="list-style-type: none"> • Low oil level. • Air leaking into suction line. • Wrong kind of oil. 	<ul style="list-style-type: none"> • Fill reservoir to proper level. • Tighten fittings, check condition of line. • Drain reservoir, fill with non-foaming oil.
Shaft seal leakage.	<ul style="list-style-type: none"> • Worn shaft seal. • Worn shaft in seal area. 	<ul style="list-style-type: none"> • Replace shaft seal. • Replace drive shaft and seal.

3) MAIN RELIEF VALVE

Problem	Cause	Remedy
Can't get pressure	<ul style="list-style-type: none"> • Poppet D, E or K stuck open or contamination under seat. 	<ul style="list-style-type: none"> • Check for foreign matter between poppets D, E or K and their mating parts. Parts must slide freely.
Erratic pressure	<ul style="list-style-type: none"> • Pilot poppet seat damaged. • Poppet C sticking in D. 	<ul style="list-style-type: none"> • Replace the relief valve. • Clean and remove surface marks for free movement.
Pressure setting not correct	<ul style="list-style-type: none"> • Normal wear. Lock nut & adjust screw loose. 	<ul style="list-style-type: none"> • See *How to set pressure on work main relief.
Leaks	<ul style="list-style-type: none"> • Damaged seats. • Worn O-rings. • Parts sticking due to contamination. 	<ul style="list-style-type: none"> • Replace the relief valve. • Install seal and spring kit. • Disassemble and clean.

★ A good pressure gauge must be installed in the line which is in communication with the main relief. A load must be applied in a manner to reach the set pressure of the main relief unit.

Then, follow these steps:

- Loosen lock nut.
- Set adjusting nut to desired pressure setting.
- If desired pressure setting cannot be achieved, add or remove shims as required.
- Tighten lock nut.
- Retest in similar manner as above.

4) LIFT CYLINDER

Problem	Cause	Remedy
Oil leaks out from gland through rod.	<ul style="list-style-type: none"> · Foreign matters on packing. · Unallowable score on rod. · Unusual distortion of dust seal. · Chrome plating is striped. 	<ul style="list-style-type: none"> · Replace packing. · Smooth rod surface with an oil stone. · Replace dust seal. · Replace rod.
Oil leaks out from cylinder gland thread.	<ul style="list-style-type: none"> · O-ring damaged. 	<ul style="list-style-type: none"> · Replace O-ring.
Rod spontaneously retract.	<ul style="list-style-type: none"> · Scores on inner surface of tube. · Unallowable score on the inner surface of tube. · Foreign matters in piston seal. 	<ul style="list-style-type: none"> · Smooth rod surface with an oil stone. · Replace cylinder tube. · Replace piston seal.
Wear(clearance between cylinder tube and wear ring)	<ul style="list-style-type: none"> · Excessive clearance between cylinder tube and wear ring. 	<ul style="list-style-type: none"> · Replace wear ring.
Abnormal noise is produced during tilting operation.	<ul style="list-style-type: none"> · Insufficient lubrication of anchor pin or worn bushing and pin. · Bent tilt cylinder rod. 	<ul style="list-style-type: none"> · Lubricate or replace. · Replace.

GROUP 3 DISASSEMBLY AND ASSEMBLY

1. MAIN PUMP

1) STRUCTURE

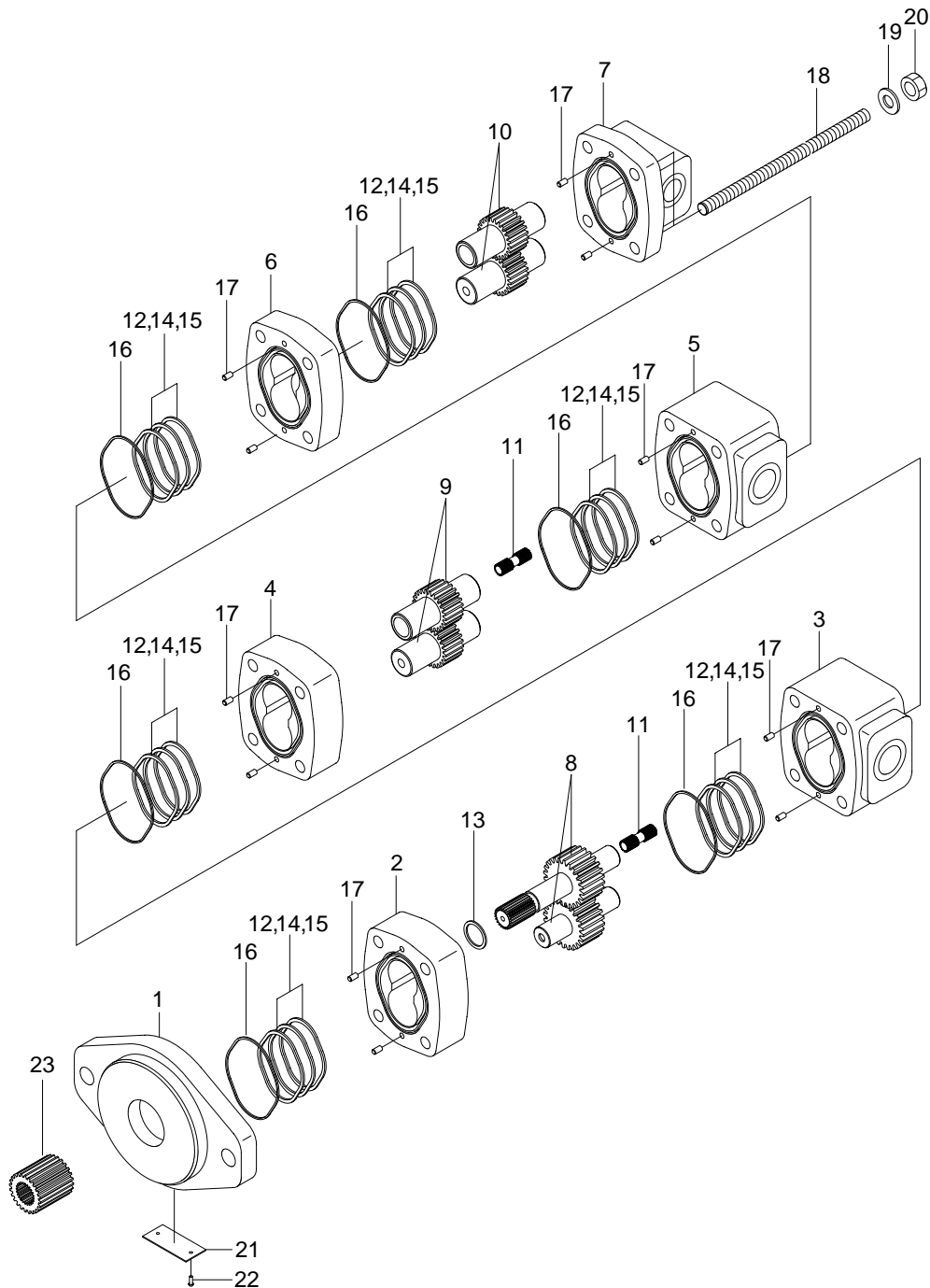

- | | | | | | |
|---|--------------|----|--------------|----|-----------|
| 1 | Cover | 8 | Gear | 15 | Seal |
| 2 | Gear housing | 9 | Gear | 16 | Seal |
| 3 | Carrier | 10 | Gear set | 17 | Dowel-pin |
| 4 | Gear housing | 11 | Shaft | 18 | Stud bolt |
| 5 | Carrier | 12 | Thrust plate | 19 | Washer |
| 6 | Gear housing | 13 | Seal | 20 | Hex-nut |
| 7 | Cover | 14 | Seal | 23 | Shaft |

50D7EHS23

2) GENERAL INSTRUCTION

(1) Cleanliness

① Cleanliness is the primary means of assuring satisfactory hydraulic pump life.

Components such as flanges and covers are best cleaned in soap and hot water, then air dried.

Gears should be washed in solvent, air dried, and oiled immediately.

▲ Certain cleaning solvents are flammable. Do not allow sources of ignition in the area when using cleaning solvents.

② Protect all exposed surfaces and open cavities from damage and foreign material.

※ Gear journals and gear faces are super finished. Take care not to touch these surfaces after oil and solvent.

(2) Lubrication of moving parts

During assembly, all running surfaces(Bearing and wear plate) must be lightly lubricated with a clean oil or aerosol lubricant.

(3) Tools required for assembly

① Socket set(1/2" drive)

② Internal snap ring pliers

③ Shaft seal sleeve or clear tape

④ Torque wrench(200lbf · ft capacity)

⑤ Plastic hammer

⑥ Torque wrench box end adapters

3) DISASSEMBLY

(1) Loosen and remove the nuts and washers from cover.



(2) Remove cover and dowel pin stud bolts from cover.



(3) Remove connection shaft, drive gear and driven gear set from gear housing.

※ When removing the gear housing, keep it as straight as possible during removal so that it can not happen scratch or damage to inner surface by touching gear teeth.



(4) Remove gear housing from carrier.
Remove thrust plate from gear housing.



(5) Remove bearing carrier from gear housing.



(6) Remove connecting shaft from gear set.
Remove thrust plate from gear housing.



(7) After taking out connecting shaft, remove gear housing, drive gear and driven gear set from cover.

- ※ When removing the gear housing, keep it as straight as possible so that it can not happen scratch or damage to inner surface by touching gear teeth.

Inspect scoring or excessive wear of shaft and gear teeth for both drive gear and driven gear set.



(8) Remove lip seal from the cover.

- ※ When remove the lip seal from the cover, take care not to give any scratch or damage on the surface of shaft hole or seal bore.



4) ASSEMBLY

(1) Thoroughly clean seal bore, press the shaft seal in to the seal bore of the cover.

- ※ Uniform pressure must be used to prevent misalignment or damage to the seal.



(2) Assemble shaft to the cover.

- ※ Thoroughly clean mounting surface of the gear housing for the seals.



- (3) Assemble gear housing and thrust plate to the cover.



- (4) Assemble gear set and thrust plate, shaft.
※ Thoroughly clean mounting surface of square seal and insert the seal in the gear housing, thrust plate.



- (5) Assemble gear housing to carrier using dowel pin.



- (6) Assemble gear housing and gear set.



- (7) Assemble carrier to gear housing using dowel pins.
Assemble gear housing to carrier using dowel pins.
- ※ Thoroughly clean mounting surface of seals, and then insert seals and thrust plate.
 - ※ Take care not to happen any damage of the seals.



- (8) Assemble last drive gear and driven gear set to the drive gear and driven gear set using connecting shaft.
Assemble cover to gear housing using dowel pin.
- ※ Thoroughly clean mounting surface of seals and then insert the seals and thrust plate.
 - ※ Take care not to happen any damage of the seals.



- (9) Assemble stud bolts, washers and fasten nuts.
· Tightening torque for nut : 15 kg · m



2. MAIN CONTROL VALVE

1) Lay out valve components on a clean, flat working surface. The inlet assembly will include an O-ring, and the spool section(s) include an O-ring, a load check poppet and a load check spring. Tools required for basic valve assembly include 3/4 and 11/16 open or box end wrenches and a torque wrench with thin wall sockets.

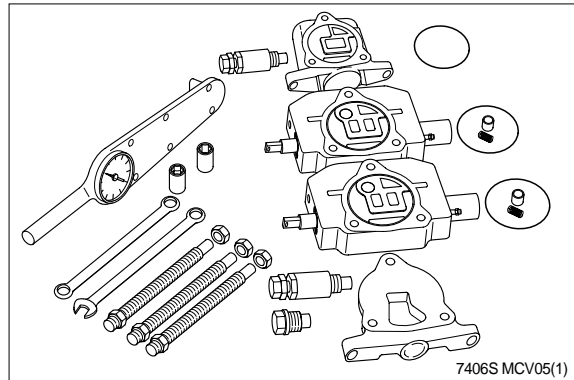

2) Assemble tie rod nuts to one end of each tie rod with one or two threads showing. Insert tie rods through tie rod holes of inlet (Large tie rod at top). Lay inlet on end with tie rods up, place O-ring into position.

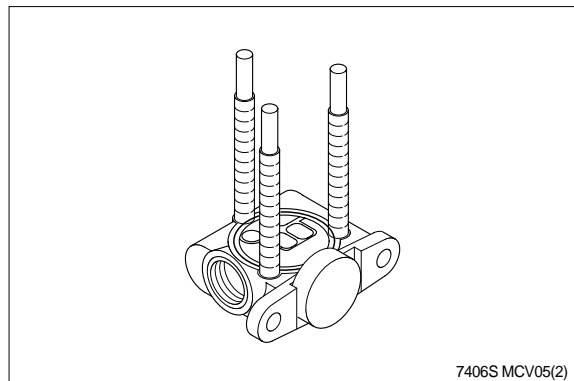

3) Place first spool section (O-ring side up) on inlet section, position O-ring and insert load check poppet (Nose down) and spring (Behind poppet) into load check cavity as shown. Repeat this procedure for each spool section; The load check springs are compressed by the following sections during assembly.

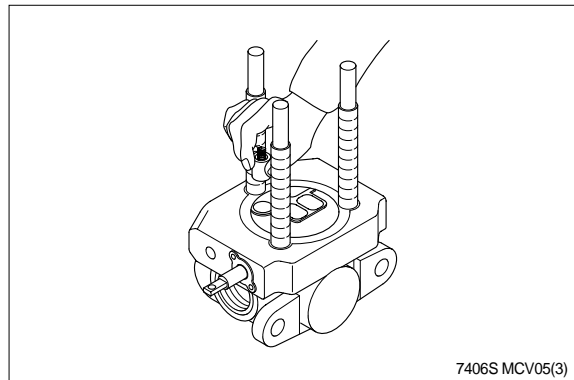

4) Position end section on last spool section as shown and hand tighten tie rod nuts. The end section on picture is a "turn around" section without ports. Universal outlet /power beyond section and power beyond and closed center sections are also used as end sections. These end sections do not have O-ring grooves.

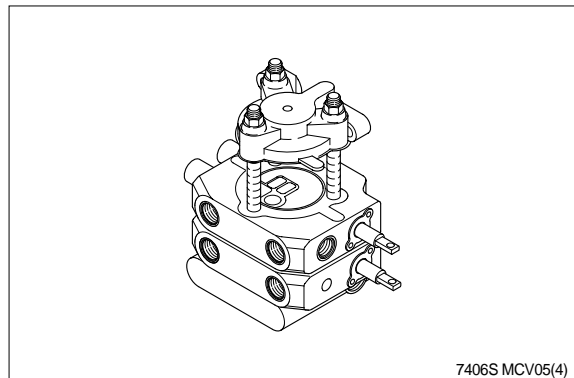

- 5) Position valve assembly with the mounting pads of the end sections on a flat surface. To obtain proper alignment of end sections relative to the spool sections apply downward pressure to the end sections ; Snug tie rod nuts to about 10lbf · ft. Final torque the two 11/16 nuts to 48 ± 5 lbf · ft ; Final torque the 3/4 nut to 74 ± 8 lbf · ft. Check for proper spool movement.

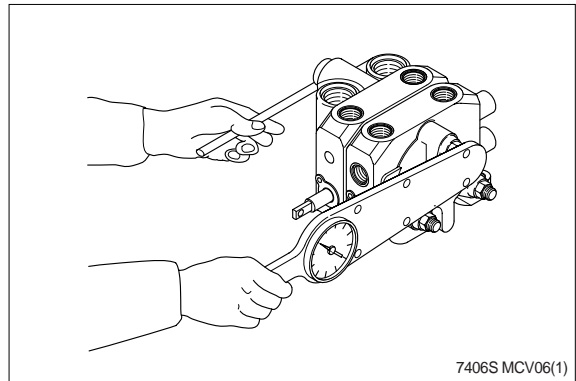

- 6) Install auxiliary valves and plugs and torque to proper specifications.
- ※ **General assembly notes:**
- A. Lever assemblies can be installed on section before or after complete valve assembly.
- B. The load check and spring may be omitted from assembly in certain circuit conditions(i.e., motor spools).

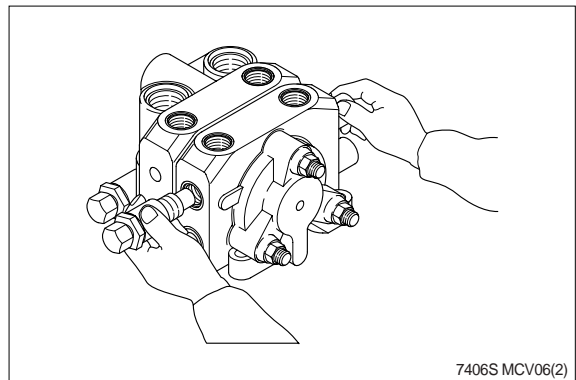

3. LIFT CYLINDER

1) STRUCTURE

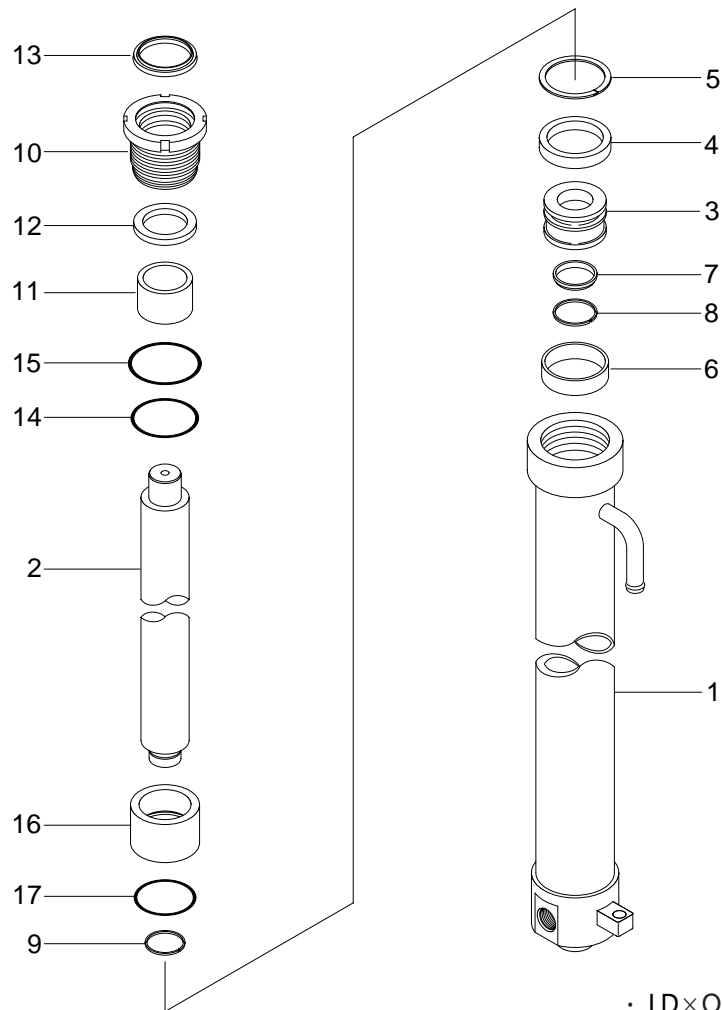

- I.D×O.D×stroke(standard)
85×98×1335mm
(3.3×3.9×52.6in)
- Rod O.D : 60mm(2.4in)

D507HS19

- | | | | |
|---|----------------|----|------------|
| 1 | Tube assy | 10 | Gland |
| 2 | Rod | 11 | Du bushing |
| 3 | Piston | 12 | Rod seal |
| 4 | Piston seal | 13 | Dust wiper |
| 5 | Back up ring | 14 | O-ring |
| 6 | Wear ring | 15 | O-ring |
| 7 | Cushion seal | 16 | Spacer |
| 8 | Retaining ring | 17 | O-ring |
| 9 | Retaining ring | | |

2) DISASSEMBLY

- (1) Hold the cylinder tube in a vice, loosen the cylinder head and remove it.
Remove the spacer from the cylinder tube and knock out the bushing. Hook a wrench in the hole in the retainer at the piston end and turn. Lever up the edge of the guide, then turn the guide in again and the guide can be removed.

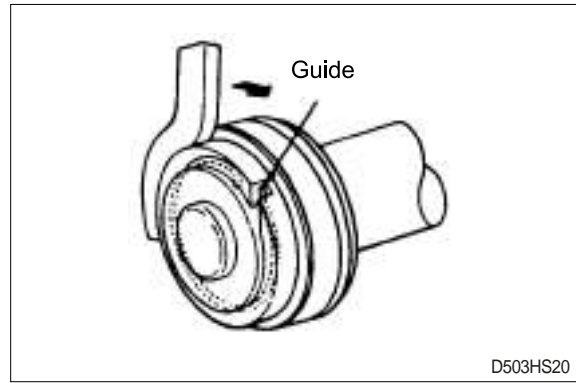

2) CHECK AND INSPECTION

mm(in)

Check item	Standard size	Repair limit	Remedy
Clearance between cylinder rod & bushing	0.05~0.25 (0.002~0.01)	0.4 (0.0015)	Replace bushing
Clearance between piston ring & tube	0.05~0.35 (0.002~0.013)	0.5 (0.02)	Replace piston ring

3) ASSEMBLY

- (1) Soak the piston ring in hydraulic oil at a temperature of 40 to 50°C, expand the inside diameter and assemble on the piston. Install a piston seal.
Bend the edge of the guide and rotate it to install the guide completely.

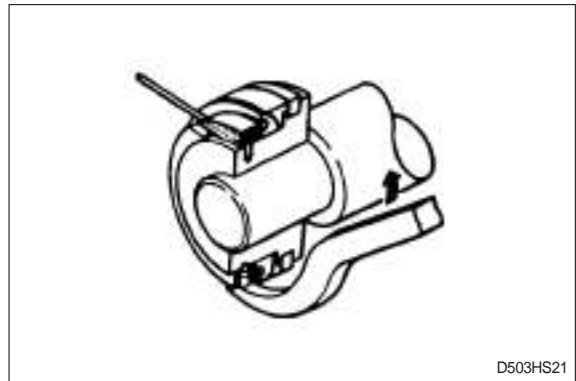

4. TILT CYLINDER

1) STRUCTURE

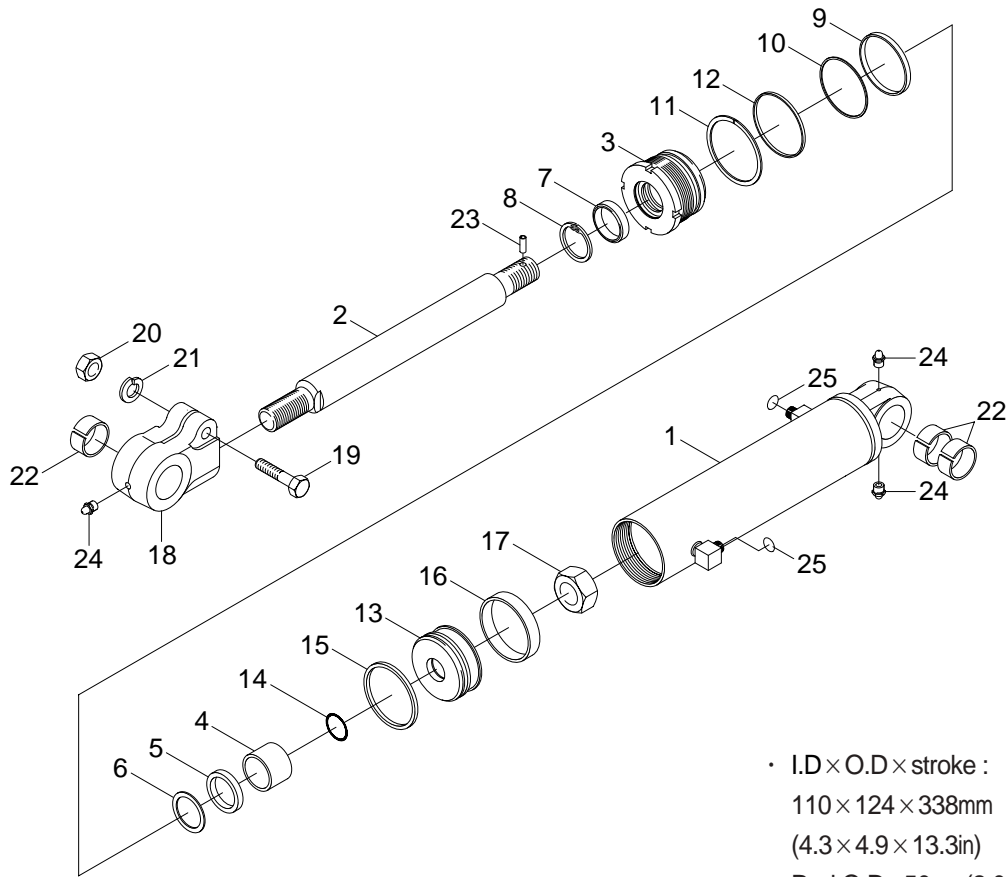

50D7EHS22

1	Tube assy	10	Back up ring	19	Hexagon bolt
2	Rod	11	Lock washer	20	Hexagon nut
3	Gland	12	O-ring	21	Spring washer
4	DU bushing	13	Piston	22	DU bushing
5	Rod seal	14	O-ring	23	Spring pin
6	Back up ring	15	Piston seal	24	Grease nipple
7	Dust wiper	16	Wear ring	25	O-ring
8	Snap ring	17	Nylon nut		
9	O-ring	18	Rod eye		

2) DISASSEMBLY

- (1) Hold the parallel parts of the cylinder tube bottom in a vice and mark the rod head end to show how much it is screwed in, then remove the rod head. Next, hook a wrench into the notch at the cylinder head and remove the cylinder head from cylinder tube.

When doing this, wind tape round the threaded part of the rod and be careful not to damage the dust seal and rod seal inside cylinder head.

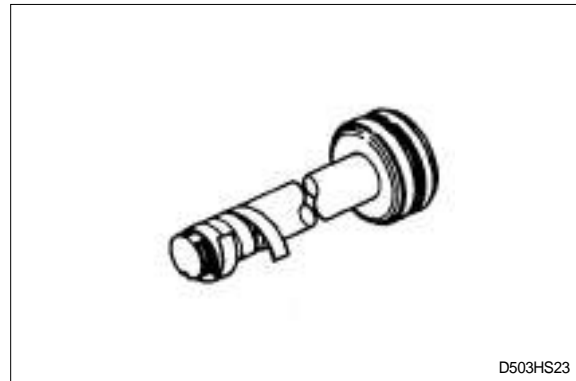

3) CHECK AND INSPECTION

mm(in)

Check item	Standard size	Repair limit	Remedy
Clearance between cylinder rod & bushing	0.072~0.288 (0.003~0.011)	0.5 (0.020)	Replace bushing
Clearance between rod head bushing & pin	0.10~0.35 (0.004~0.014)	0.6 (0.024)	Replace bushing

SECTION 7 ELECTRICAL SYSTEM

GROUP 1 COMPONENT LOCATION

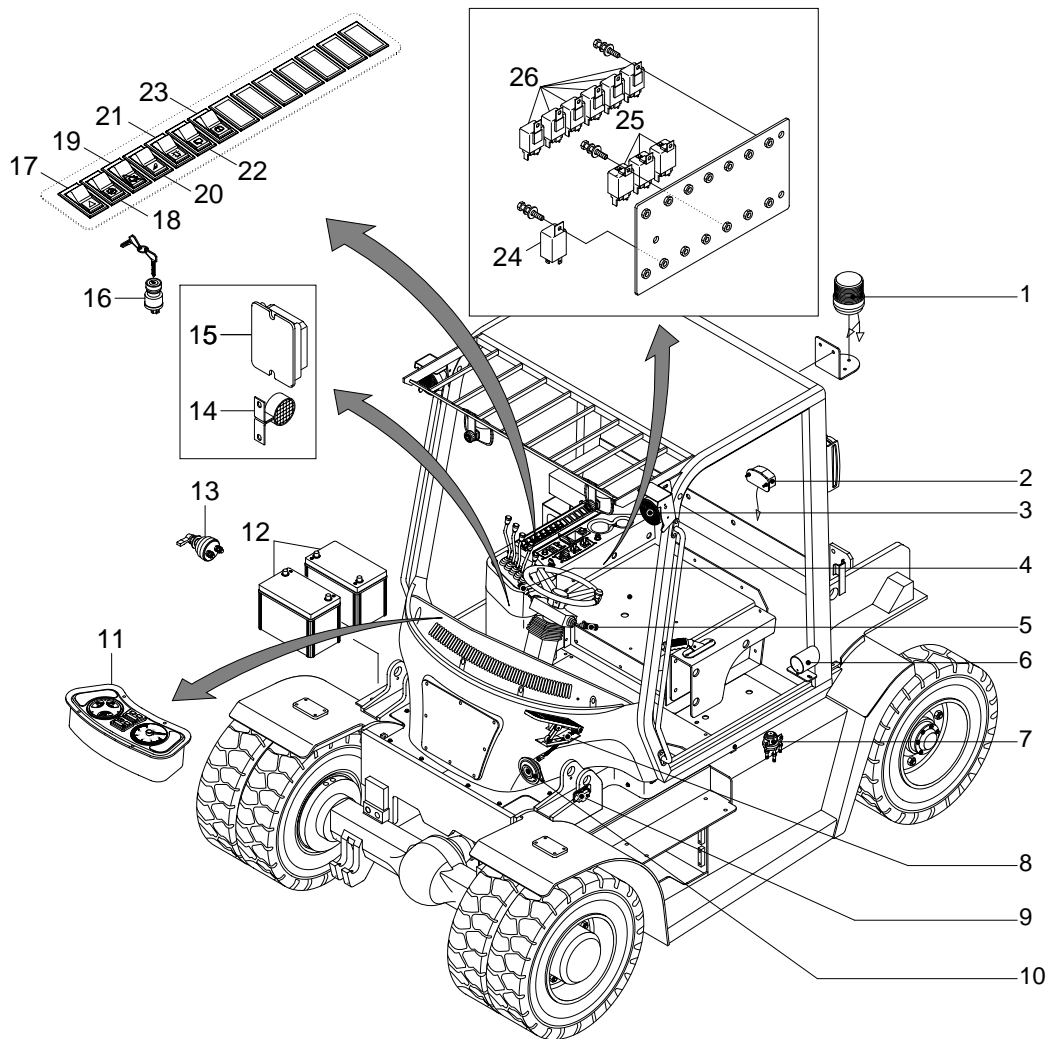

50D7EEL00

- | | | |
|----------------------|--------------------------|--------------------------|
| 1 Beacon lamp | 10 High horn | 19 Full automatic switch |
| 2 License lamp | 11 Cluster | 20 Work lamp switch |
| 3 Work lamp | 12 Battery | 21 Beacon switch |
| 4 Combination switch | 13 Master switch | 22 Wiper switch |
| 5 Gear selector | 14 Buzzer | 23 Washer switch |
| 6 Backup alarm | 15 OPSS unit | 24 Flasher unit |
| 7 Start relay | 16 Start switch | 25 Relay 5P |
| 8 Accelerator pedal | 17 Hazard switch | 26 Relay 4P |
| 9 Micro switch | 18 Clutch cut-off switch | |

GROUP 2 ELECTRICAL CIRCUIT

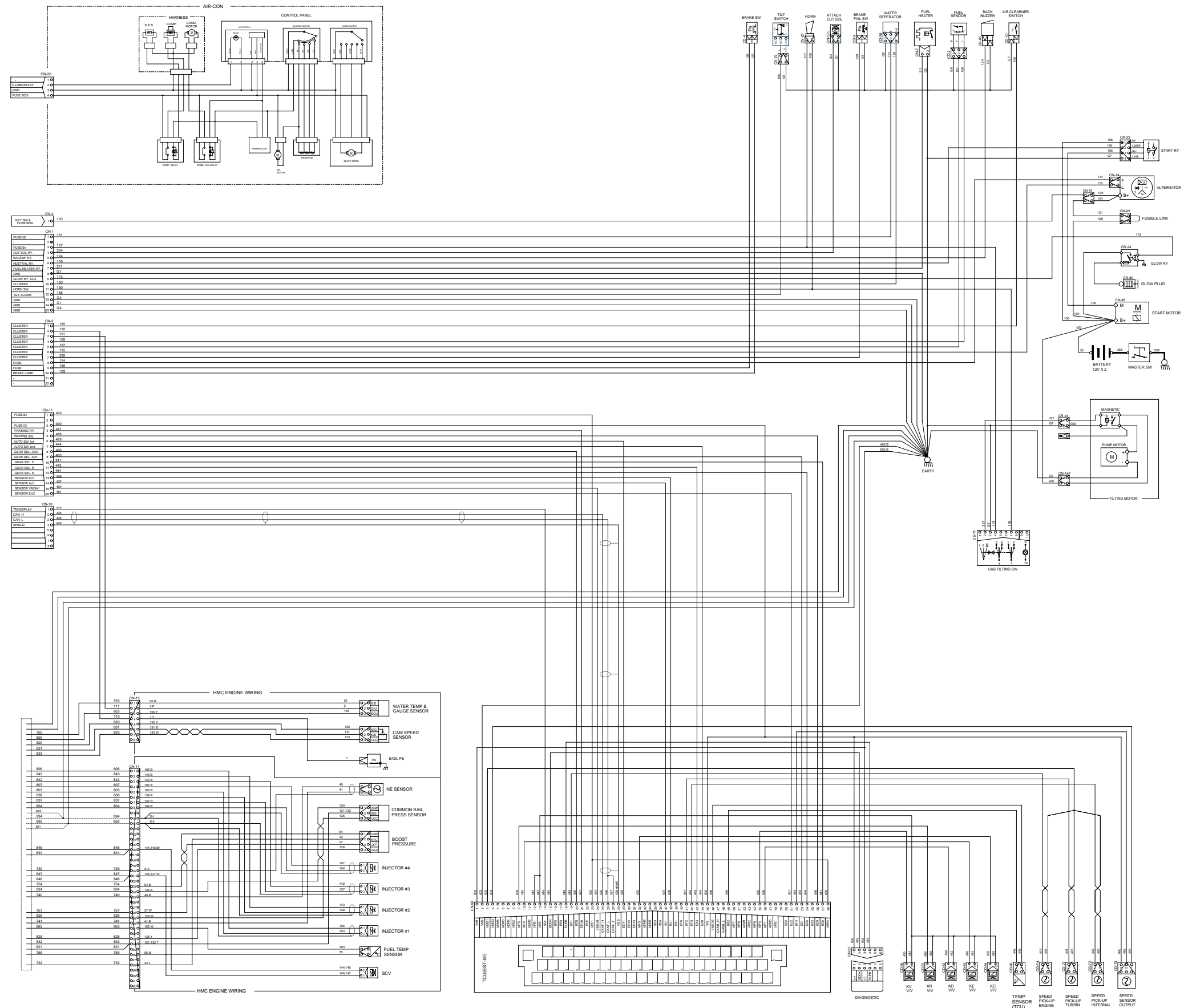



1. POWER CIRCUIT

The negative terminal of the battery is grounded to the machine chassis.

When the start switch is in the off position, the current flows from the positive battery terminal.

1) OPERATING FLOW

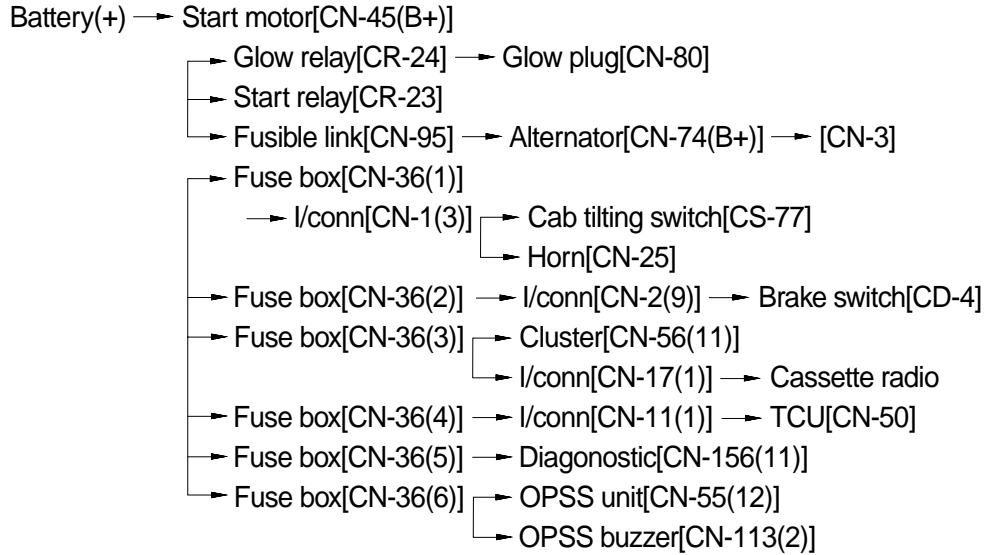

2) CHECK POINT

Engine	Key switch	Check point	Voltage
OFF	OFF	① - GND (Battery(+)) ② - GND (Fusible link) ③ - GND (Fuse No.1) ④ - GND (Fuse No.4) ⑤ - GND (Start key)	24V

※ GND : Ground

POWER CIRCUIT

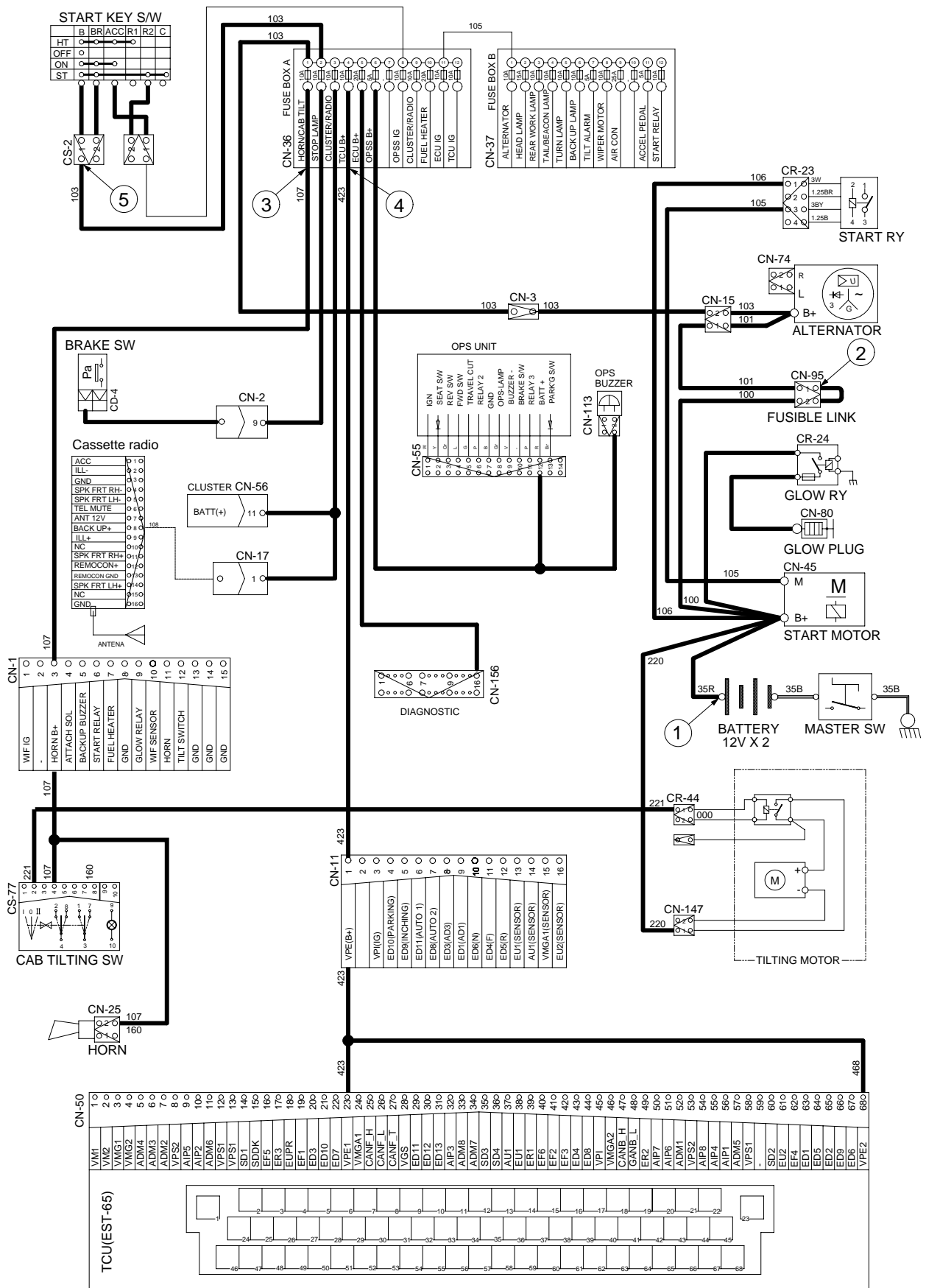

50D7EEL03

2. STARTING CIRCUIT

1) OPERATING FLOW

Battery(+) terminal

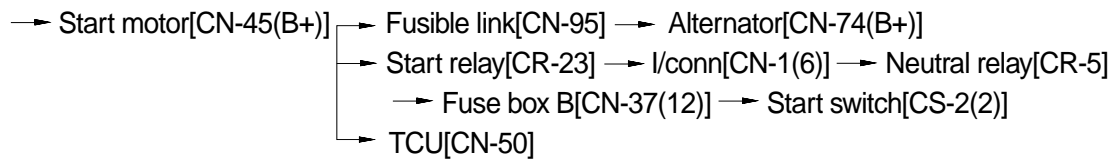

※ The engine can be started only when the gearshift is in neutral position.
The operator should be seated when starting.

(1) When start key switch is in ON position

Start switch ON [CS-2(1)] → Fuse box A[No.2 →12] → Gear selector switch[CS-15(A)]

(2) When start key switch is START position

Start switch START[CS-2(2)] → Fuse box B[No. 12] → Neutral relay[CR-5(2) → (4)]
→ I/conn[CN-1(6)] → Start relay[CR-23]

2) CHECK POINT

Engine	Key switch	Check point	Voltage
Running	ON	① - GND (Battery B+) ② - GND (Fusible link) ③ - GND (Fuse box B No.1, 12) ④ - GND (Start key) ⑤ - GND (Neutral relay)	24V

※ GND : Ground

STARTING CIRCUIT

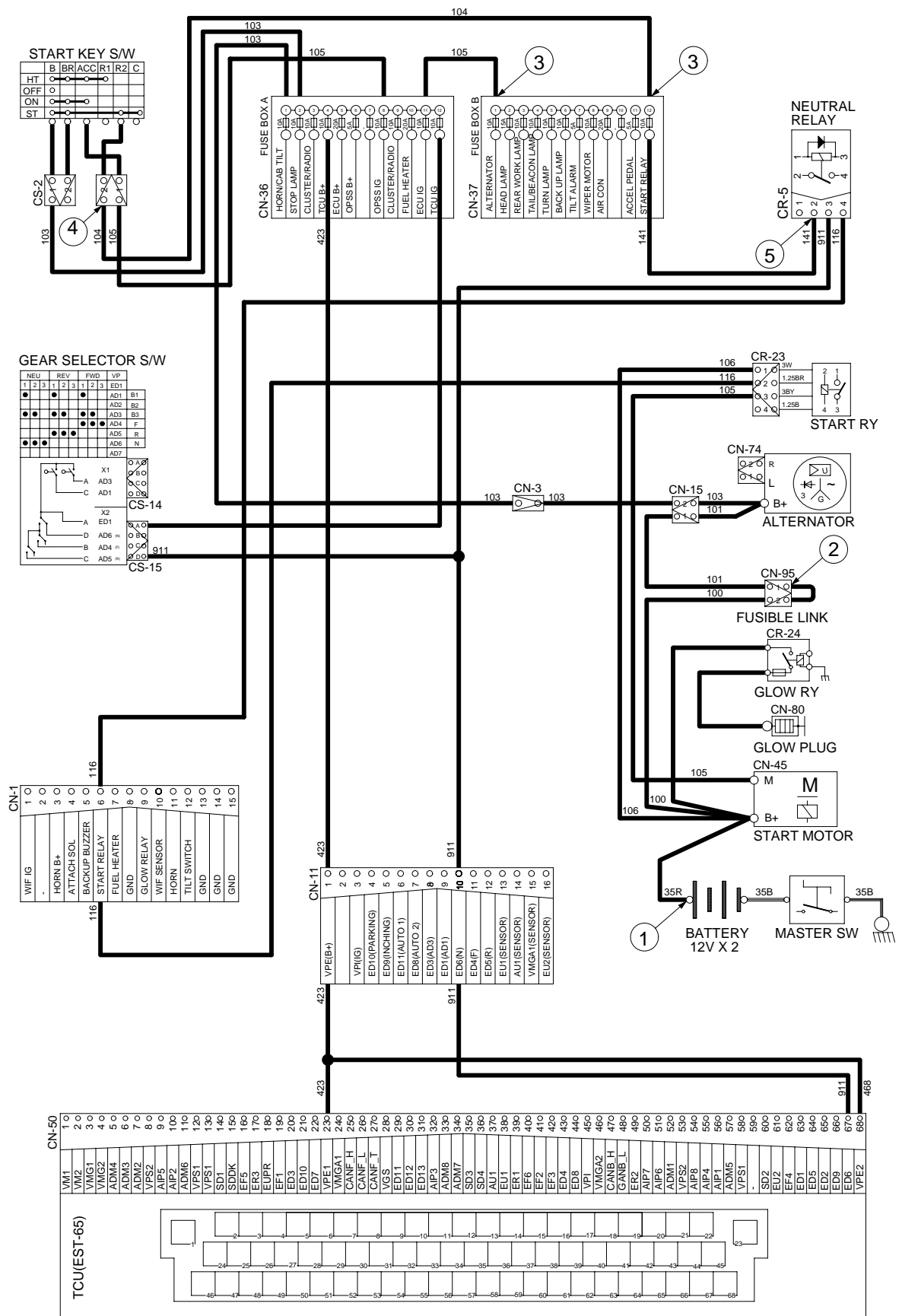

50D7EEL04

3. CHARGING CIRCUIT

When the starter is activated and the engine is started, the operator release the start switch to the ON position. Charging current generated by operating alternator flows into the battery. The current also flows from alternator to each electrical component through the fusible link(CN-60) and the fuse box.

1) OPERATING FLOW

(1) Warning flow

Alternator[CN-74(L)] → I/conn[CN-2(6)] → Cluster charging lamp ON [CN-56(4)]

(2) Charging flow

Alternator[CN-74(B+)] → Fusible link[CN-95] → Starter[CN-45(B+)] → Battery(+) terminal charging
 Alternator[CN-74(B+)] → I/conn[CN-3] → Fuse box

2) CHECK POINT

Engine	Key switch	Check point	Voltage
ON	ON	① - GND (Alternator B+) ② - GND (Start switch) ③ - GND (Cluster)	24V

※ GND : Ground

※ Cautions

1. When using an arc welder, always disconnect the ground lead from the battery to prevent alternator or battery damage.
2. Attach the welding ground clamp as close to the weld area as possible to prevent welding current from damaging the bearings of the alternator.
3. Do not disconnect the battery when the engine is running. The voltage surge can damage the diode and resistors in the electrical system.
4. Do not disconnect an electric wire before the engine is stopped and the switches are OFF.

CHARGING CIRCUIT

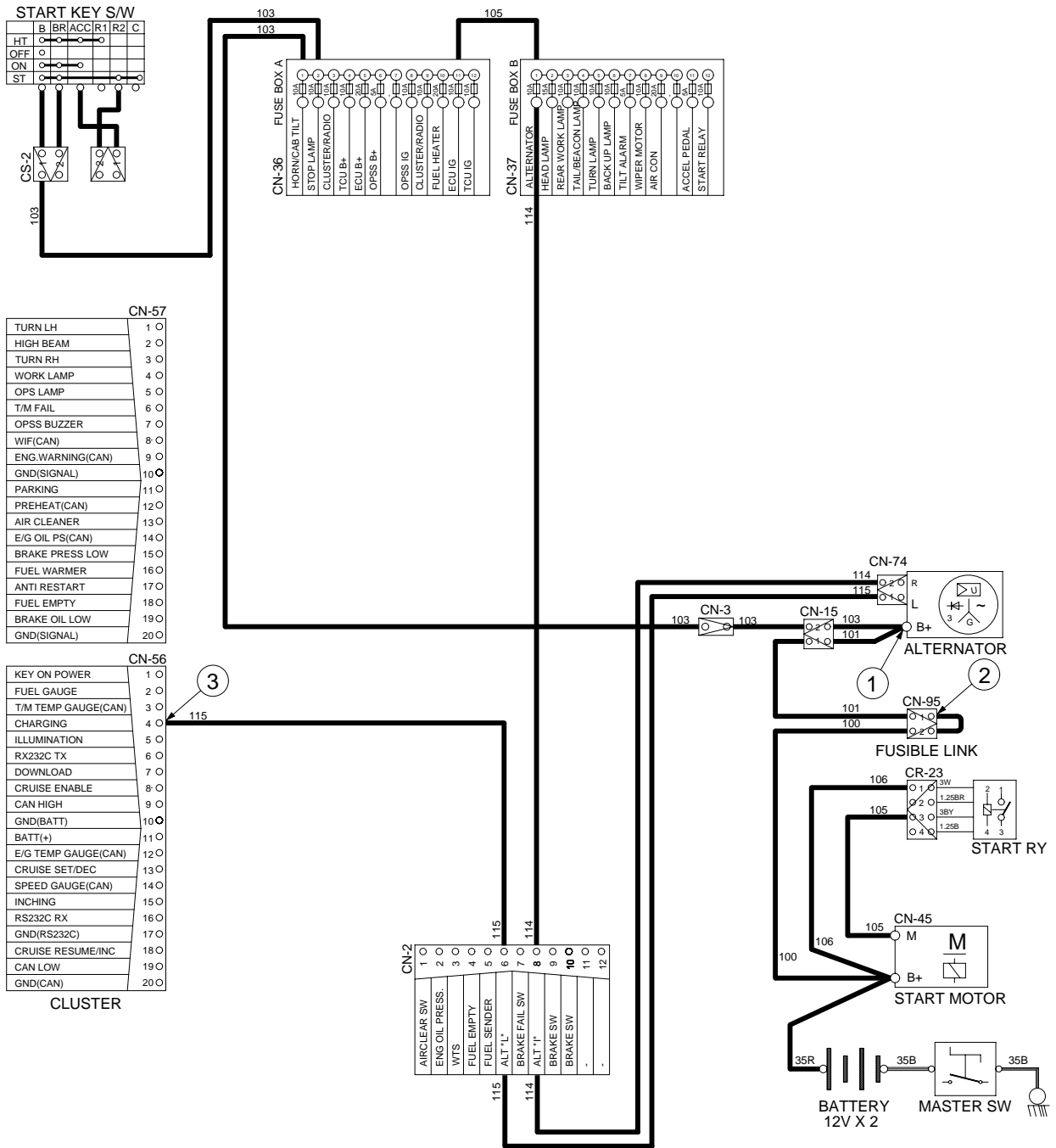

50D7EEL05

4. PREHEATING CIRCUIT

Combustion chamber glow plugs are used in order to give satisfactory starting of low ambient temperatures.

1) OPERATING FLOW

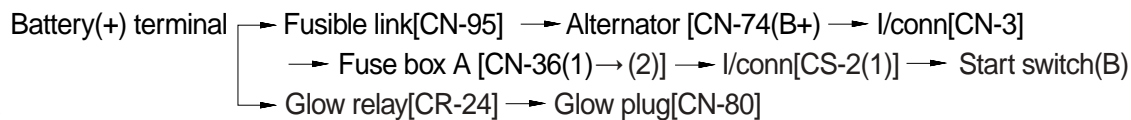

※

When you turn the start switch to the ON position, the glow relay makes the glow plugs operated and the glow lamp of the cluster turned ON.

Start switch ON [CS-2(1)]

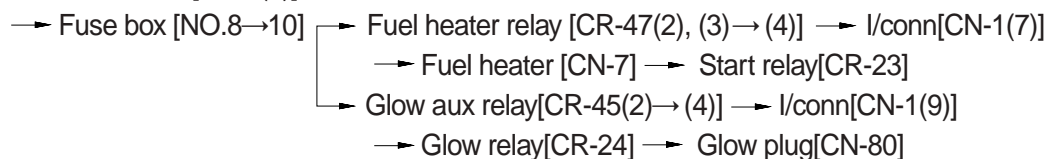

2) CHECK POINT

Engine	Key switch	Check point	Voltage
Stop	HEAT	① - GND (Battery B+) ② - GND (Fusible link) ③ - GND (Glow plug) ④ - GND (Glow relay) ⑤ - GND (Start switch) ⑥ - GND (Glow lamp)	24V

PREHEATING CIRCUIT

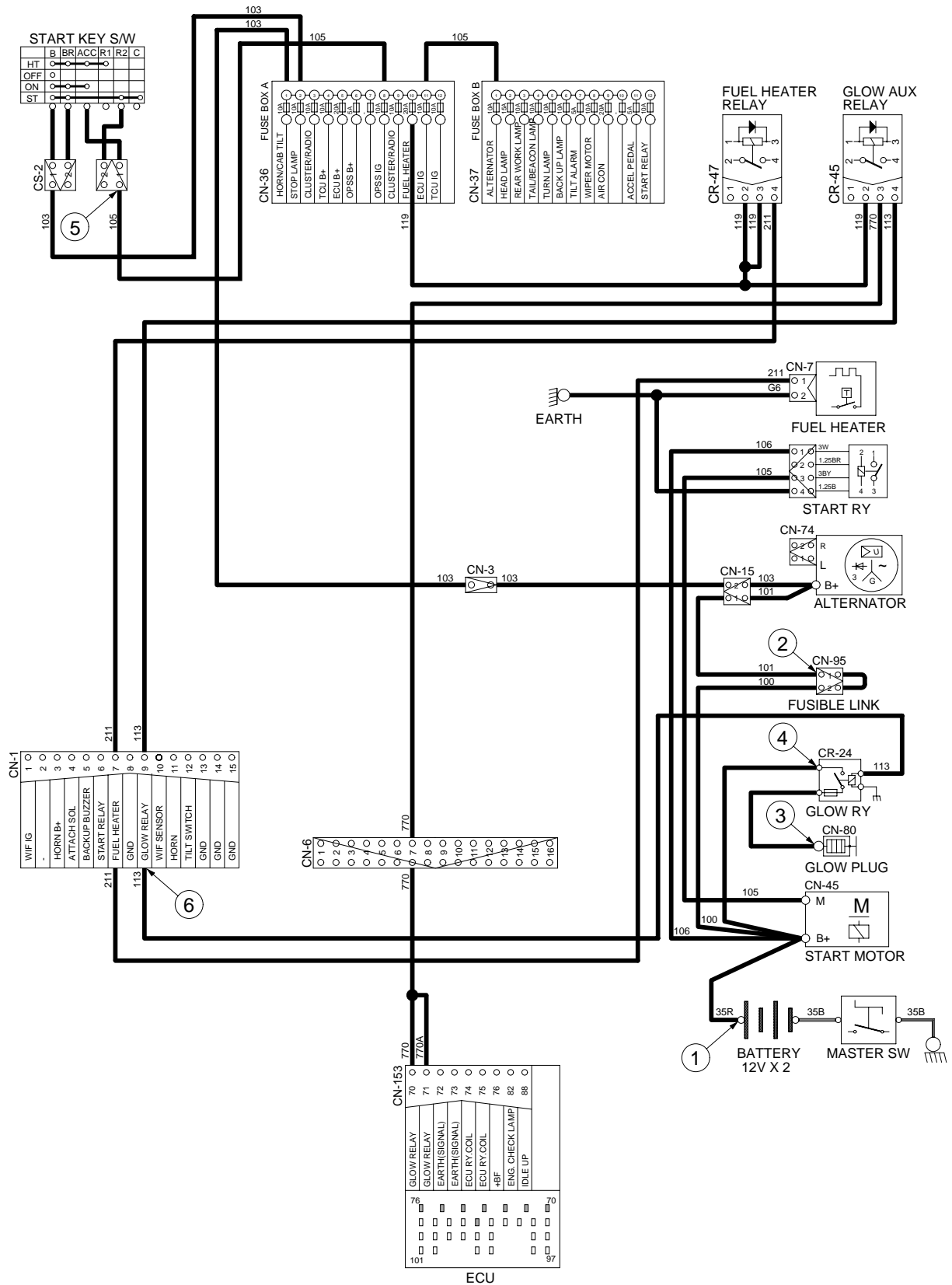

50D7EEL07

GROUP 3 COMPONENT SPECIFICATION

No	Part name	Qty	Specification														
1	Battery	2	12V×80AH RC : 130min CCA : 630A														
2	Working lamp	1	24V, 70W														
3	License lamp	1	24V, 3W x 2														
4	Rear Combination lamp	2	24V, 25/10W (Stop/Tail) 24V, 25W (Turn) 24V, 25W (Back Up)														
5	Head lamp	2	24V, 70W														
6	Flasher lamp	2	24V, 25/10W														
7	Glow relay	1	24V, 300A														
8	Relay (4P)	4	24V, 20A														
9	Relay (5P)	3	24V, 6A														
10	Flasher Unit	1	85±10CM, (21W + 21W) x 2 + 3W x 2														
11	Back buzzer	1	24V, 90±5dB, 60±10C/M														
12	Horn	1	24V, 1.5A, 100 ~ 115 dB														
13	Fuel level sender	1	<table border="1" style="width: 100%; border-collapse: collapse; text-align: center;"> <tr> <td style="width: 25%;">Float indicate</td> <td style="width: 12.5%;">E</td> <td style="width: 12.5%;">1/2</td> <td style="width: 12.5%;">F</td> </tr> <tr> <td>Resistance(Ω)</td> <td>105</td> <td>32.5</td> <td>5</td> </tr> <tr> <td rowspan="2">Tolerance(Ω)</td> <td>+0</td> <td rowspan="2">±2.5</td> <td>+0.5</td> </tr> <tr> <td>-5</td> <td>-0</td> </tr> </table>	Float indicate	E	1/2	F	Resistance(Ω)	105	32.5	5	Tolerance(Ω)	+0	±2.5	+0.5	-5	-0
Float indicate	E	1/2	F														
Resistance(Ω)	105	32.5	5														
Tolerance(Ω)	+0	±2.5	+0.5														
	-5		-0														
14	Master Switch	1	24V, 180A														
15	Combination Switch	1	Direction 4.5A, Tail 5A Head 6A, Horn 4A														
16	Brake Switch	1	24V, 50W														
17	Working Lamp Switch	1	24V, 8A														
18	Hazard Switch	1	24V, 8A														
19	Beacon Inching	1	24V, 8A														
20	Auto manual Switch	1	24V, 8A														
21	Start switch	1	24V, 30A														
22	Fusible link	1	24V, 45A														
23	Start relay	1	24V, 300A														
24	Seat switch	1	24V, 8A														
25	Tilt switch	1	24V, 8A														
26	Warning buzzer	1	24V, 200mA, 90±5dB (l m)														

GROUP 4 CONNECTOR DESTINATION

Connector number	Type	No. of pin	Destination	Connector part No.	
				Female	Male
CN-1	AMP	15	I/conn(Console harness-frame harness)	2-85262-1	368301-1
CN-2	AMP	12	I/conn(Frame harness-console harness)	S816-012002	174657-2
CN-3	KET	1	I/conn(Frame harness-console harness)	MG640944-5	MG650943-5
CN-6	AMP	16	I/conn(ECU harness)	368047-1	368050-1
CN-7	BOSCH	2	Fuel heater	1-928-402-404	
CN-8	AMP	8	Transmission display	929504-3	-
CN-9	AMP	4	TCU service tool	174257-2	174259-2
CN-10	AMP	8	I/conn(Console harness-T/M harness)	S816-008002	S816-108002
CN-11	AMP	16	I/conn(Console harness-T/M harness)	368047-1	S816-116002
CN-13	NMWP	8	HMC engine harness	PB625-08027	-
CN-14	AMP	42	HMC engine harness	936421	-
CN-15	SMITOMO	2	Alternator (B+)	6189-0172	-
CN-17	AMP	12	Cabin	S816-012002	-
CN-19	KET	2	Output check	S814-002100	MG610320
CN-20	KET	4	Aircon harness	MG641744-5	-
CN-21	AMP	6	Wiper motor	936257-2	-
CN-22	KET	2	Washer tank	MG640605	-
CN-25	MOLEX	2	Horn	35825-0211	-
CN-26	KET	2	Tilt alarm	S822-014000	S822-114000
CN-36	-	-	Fuse box	21HF-10500	-
CN-37	-	-	Fuse box	21HF-10500	-
CN-45	RING TERM	2	Start motor	S820-308000	-
CN-50	AMP	68	Transmission control unit	963598-1	-
CN-51	AMP	6	Diagnostic	926682-3	-
CN-55	KET	14	OPS unit	S814-014100	-
CN-56	AMP	20	Cluster	174047-2	-
CN-57	AMP	20	Cluster	175967-2	-
CN-65	KET	2	Back buzzer	S822-014000	S822-114000
CN-74	KET	2	Alternator	MG640188-4	-
CN-80	RING TERM	1	Glow plug	S820-204000	-
CN-98	KET	2	Resistor	DT06-3S-EP06	-
CN-113	AMP		OPSS buzzer	21N4-01111	-
CN-131	AMP	2	Cut off sol 1(tilt)	S816-002002	-
CN-144	AMP	6	Accelerator pedal	S816-006002	-
CN-147	KET	2	Cabin tilting lamp	MG640188-4	-
CN-151	AMP	34	ECU	1123337-1	-

Connector number	Type	No. of pin	Destination	Connector part No.	
				Female	Male
CN-152	AMP	35	ECU	1123338-1	-
CN-153	AMP	32	ECU	1123339-1	-
CN-154	AMP	35	ECU	1123340-1	-
CN-155	AMP	31	ECU	1123341-1	-
CN-156	MOLEX	16	ECU diagnostic	51115-1601	-
CN-157	KET	2	CAN	MG651026(L)	-
CN-169	DEUTSCH	4	RS232C	DT06-4S-EP06	DT04-4P-E005
Switch					
CS-2	KET	2	Start switch	MG620181	MG620282
CS-5	KET	2	Horn switch	S814-102100	-
CS-11	KET	4	Combination switch	S810-004201	-
CS-12	KET	3	Combination switch	S810-003201	-
CS-14	PACKARD	4	Gear selector switch	12010974	-
CS-15	PACKARD	4	Gear selector switch	12015797	-
CS-17	KET	3	Parking switch	S810-003201	-
CS-23	SWF	10	Beacon lamp switch	593757	-
CS-41	SWF	10	Hazard switch	593757	-
CS-42	SWF	10	Inching switch	593757	-
CS-59	SWF	10	Auto manual switch	593757	-
CS-69	SWF	10	Rear work switch	593757	-
CS-72	KET	2	Tilt switch	MG610320	-
CS-73	KET	2	Seat switch	S810-002201	-
CS-77	SWF	12	Cabin tilting switch	593757	-
Lamp					
CL-15	KET	6	Combination lamp-LH	S814-006100	-
CL-16	KET	6	Combination lamp-RH	S814-006100	-
CL-21	KET	2	License lamp	S822-014000	S822-114000
Relay					
CR-5	KET	4	Neutral relay	S810-004201	-
CR-11	-	3	Flasher unit relay	S810-003702	-
CR-13	KET	4	Head lamp relay	S810-004201	-
CR-23	KET	2	Start relay	S814-002100	S814-102100
CR-24	KET	1	Glow relay	S822-014000	-
CR-34	KET	6	Parking relay	S810-006202	-
CR-35	KET	4	Back up relay	S810-004201	-
CR-40	KET	6	Illumination relay	S810-006202	-
CR-43	KET	4	ECU power relay	S810-004201	-
CR-44	AMP	2	Cabin tilting relay	17435202	-
CR-45	KET	4	Glow aux relay	S810-004201	-

Connector number	Type	No. of pin	Destination	Connector part No.	
				Female	Male
CR-47	KET	4	Fuel heater	S810-004201	-
CR-50	KET	6	Tilt cut-off relay	S810-006202	-
Sensor and pressure switch					
CD-2	KET	3	Fuel sensor	S810-003201	-
CD-3	DEUTSCH	2	Brake fail pressure	-	DT04-2P-E005
CD-4	AMP	2	Stop lamp switch	171809-2	-
CD-10	KET	1	Air cleaner switch	ST730057-2	-
CD-27	AMP	2	Turbin speed input	963040-3	-
CD-38	-	2	Water separator	-	S816-102003
CD-71	AMP	6	Inching sensor	1-967616-1	-
CD-72	AMP	2	Gear train speed sensor	963040-3	-
CD-73	AMP	3	Output speed sensor	282087	-
CD-74	AMP	2	Engine speed sensor	963040-3	-
CD-80	PACKARD	2	KV Solenoid	12162197	-
CD-81	PACKARD	2	KR Solenoid	12162197	-
CD-82	PACKARD	2	KD Solenoid	12162197	-
CD-83	PACKARD	2	KE Solenoid	12162197	-
CD-84	PACKARD	2	KC Solenoid	12162197	-
CD-90	AMP	2	Temp sensor	963040-3	-
DO-01	-	2	Diode	21EA-50550	-

GROUP 5 TROUBLESHOOTING

Trouble symptom	Probable cause	Remedy
Lamps dimming even at maximum engine speed.	<ul style="list-style-type: none"> • Faulty wiring. 	<ul style="list-style-type: none"> • Check for loose terminal and disconnected wire.
Lamps flicker during engine operation.	<ul style="list-style-type: none"> • Improper belt tension. 	<ul style="list-style-type: none"> • Adjust belt tension.
Charge lamp does not light during normal engine operation.	<ul style="list-style-type: none"> • Charge lamp defective. • Faulty wiring. 	<ul style="list-style-type: none"> • Replace. • Check and repair.
Alternator makes abnormal sounds.	<ul style="list-style-type: none"> • Alternator defective. 	<ul style="list-style-type: none"> • Replace
Starting motor fails to run.	<ul style="list-style-type: none"> • Faulty wiring. • Insufficient battery voltage. 	<ul style="list-style-type: none"> • Check and repair. • Recharge battery.
Starting motor pinion repeats going in and out.	<ul style="list-style-type: none"> • Insufficient battery voltage. 	<ul style="list-style-type: none"> • Recharge battery.
Excessively low starting motor speed.	<ul style="list-style-type: none"> • Insufficient battery voltage. • Starting motor defective. 	<ul style="list-style-type: none"> • Recharge battery. • Replace
Starting motor comes to a stop before engine starts up.	<ul style="list-style-type: none"> • Faulty wiring. • Insufficient battery voltage. 	<ul style="list-style-type: none"> • Check and repair. • Recharge battery.
Heater signal does not become red.	<ul style="list-style-type: none"> • Faulty wiring. • Glow plug damaged. 	<ul style="list-style-type: none"> • Check and repair. • Replace
Engine oil pressure caution lamp does not light when engine is stopped (with starting switch left in "ON" position).	<ul style="list-style-type: none"> • Caution lamp defective. • Caution lamp switch defective. 	<ul style="list-style-type: none"> • Replace • Replace

SECTION 8 MAST

GROUP 1 STRUCTURE

1. 2 STAGE MAST(V MAST)

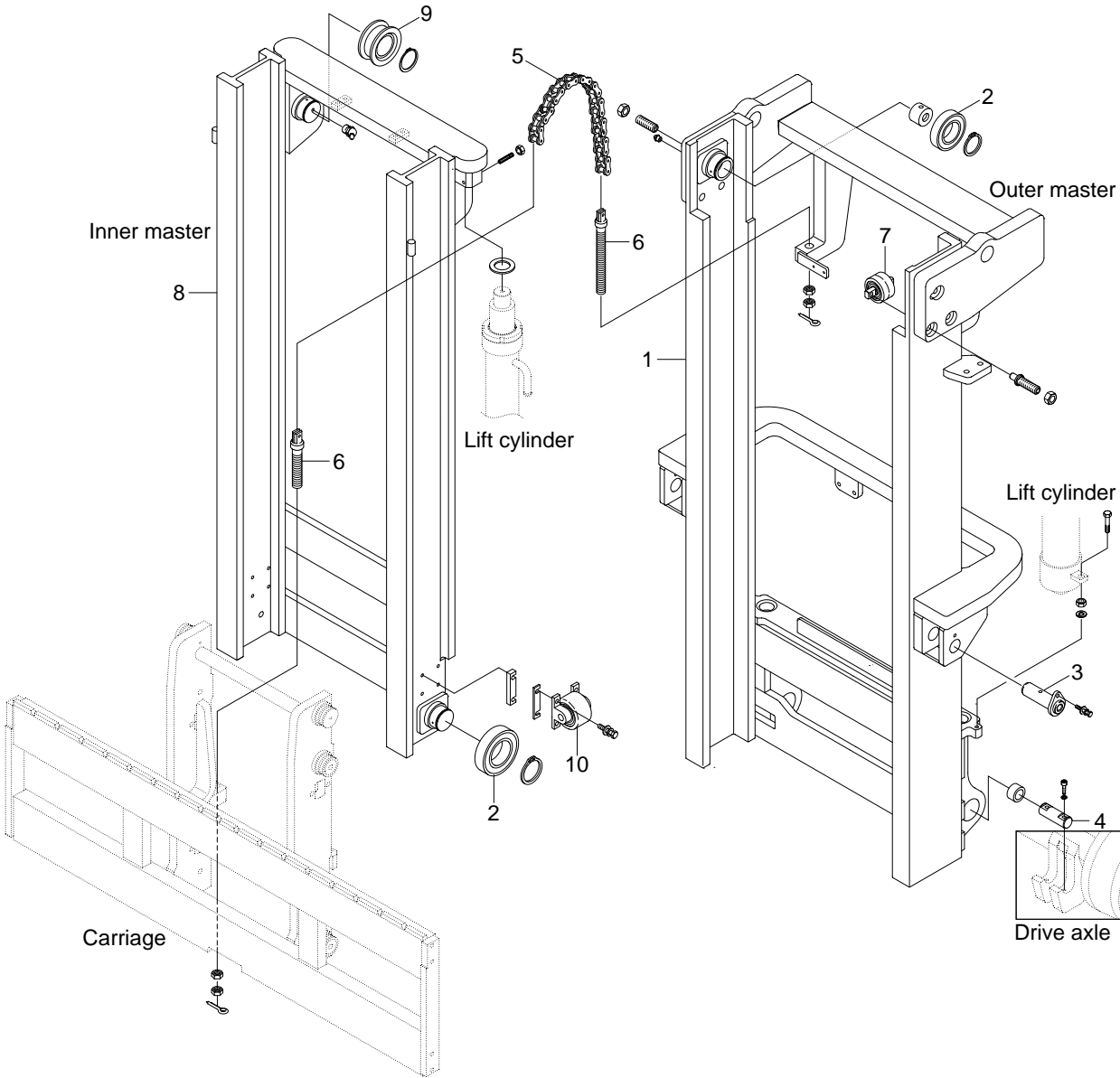

50D7EMS01

- | | | | | | |
|---|-------------------|---|---------------------|----|----------------------|
| 1 | Outer mast | 5 | Lift chain | 9 | Chain sheave bearing |
| 2 | Roller bearing | 6 | Anchor bolt | 10 | Side roller bearing |
| 3 | Tilt cylinder pin | 7 | Side roller bearing | | |
| 4 | Mast mounting pin | 8 | Inner mast | | |

2. 3 STAGE MAST(TF MAST)

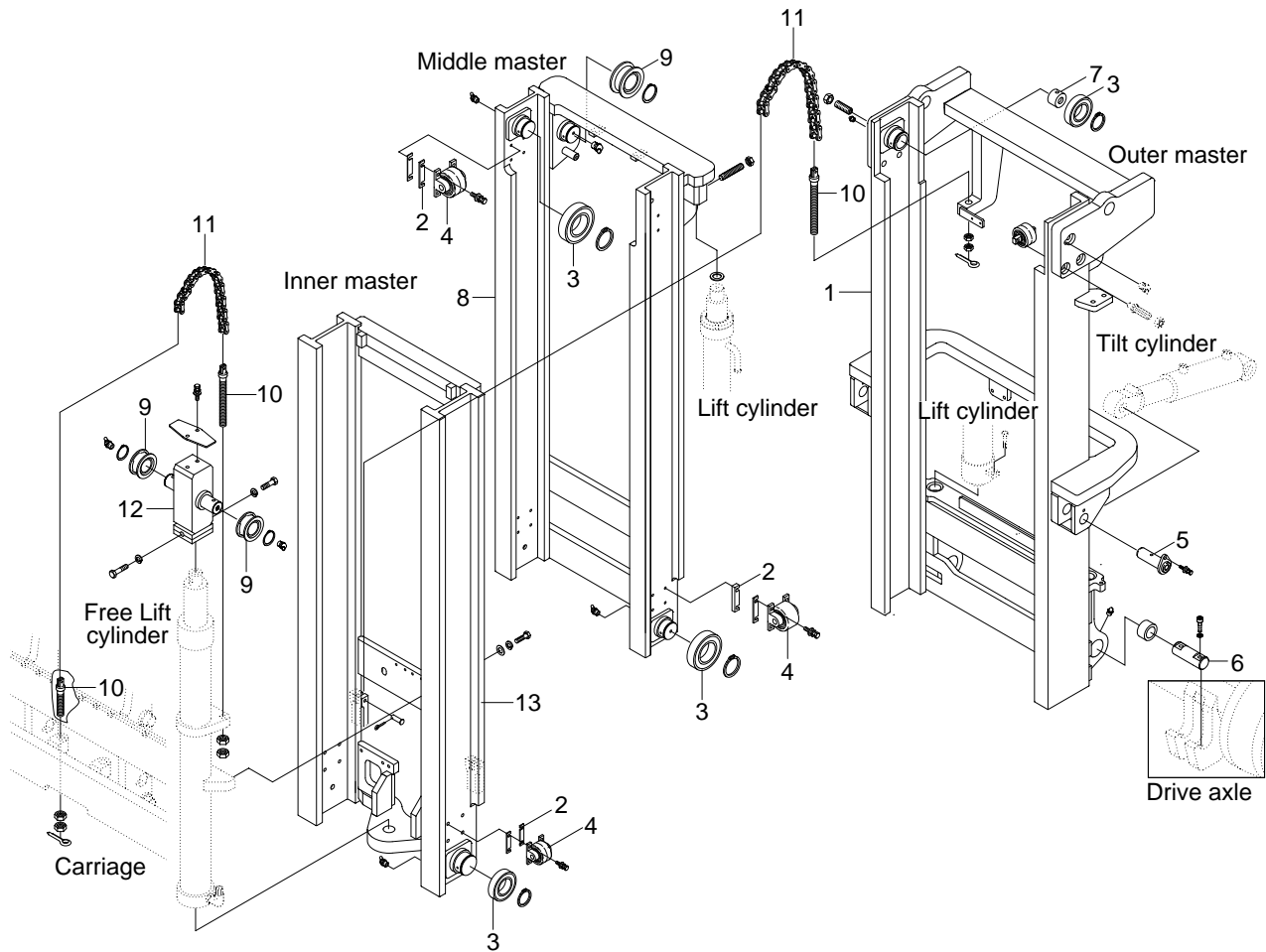

50D7EMS011

- | | | | | | |
|---|---------------------|----|-------------------|----|----------------|
| 1 | Outer mast | 6 | Mast mounting pin | 11 | Chain |
| 2 | Shim | 7 | Wear plug | 12 | Sheave bracket |
| 3 | Roller bearing | 8 | Middle mast | 13 | Inner mast |
| 4 | Side roller bearing | 9 | Sheave | | |
| 5 | Tilt cylinder pin | 10 | Anchor bolt | | |

3. CARRIAGE, BACKREST AND FORK

1) HOOK ON TYPE(STD)

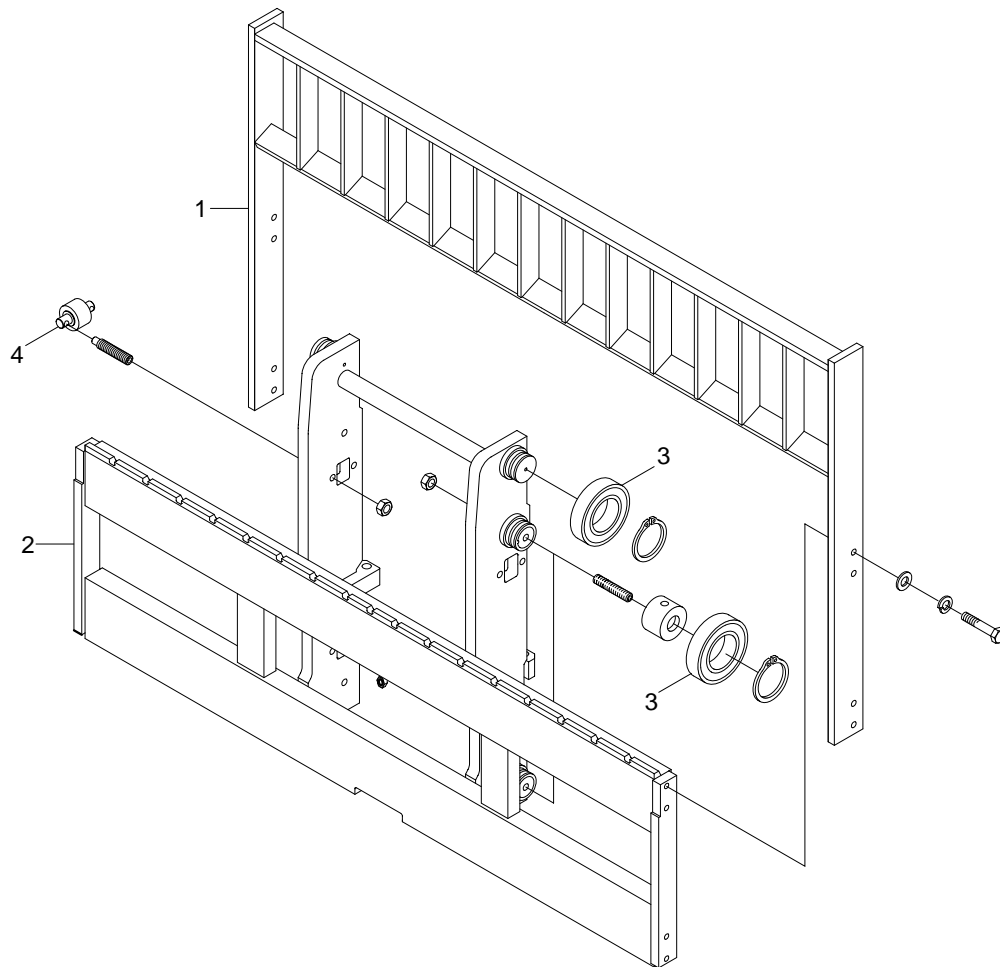

Hook on type fork

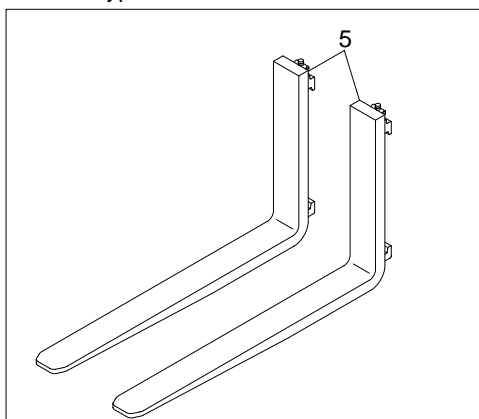

Extension fork

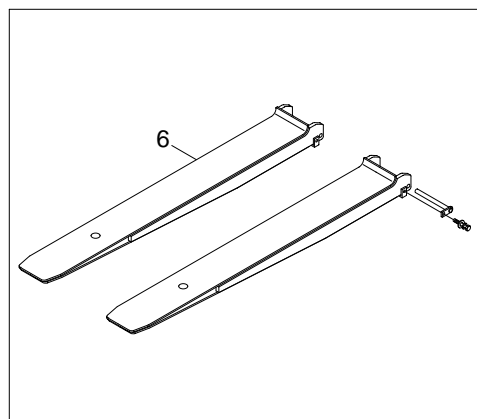

50DS7EMS03

- 1 Backrest
- 2 Carriage
- 3 Roller

- 4 Side roller
- 5 Fork
- 6 Extension fork

2) SHAFT TYPE(OPTION)

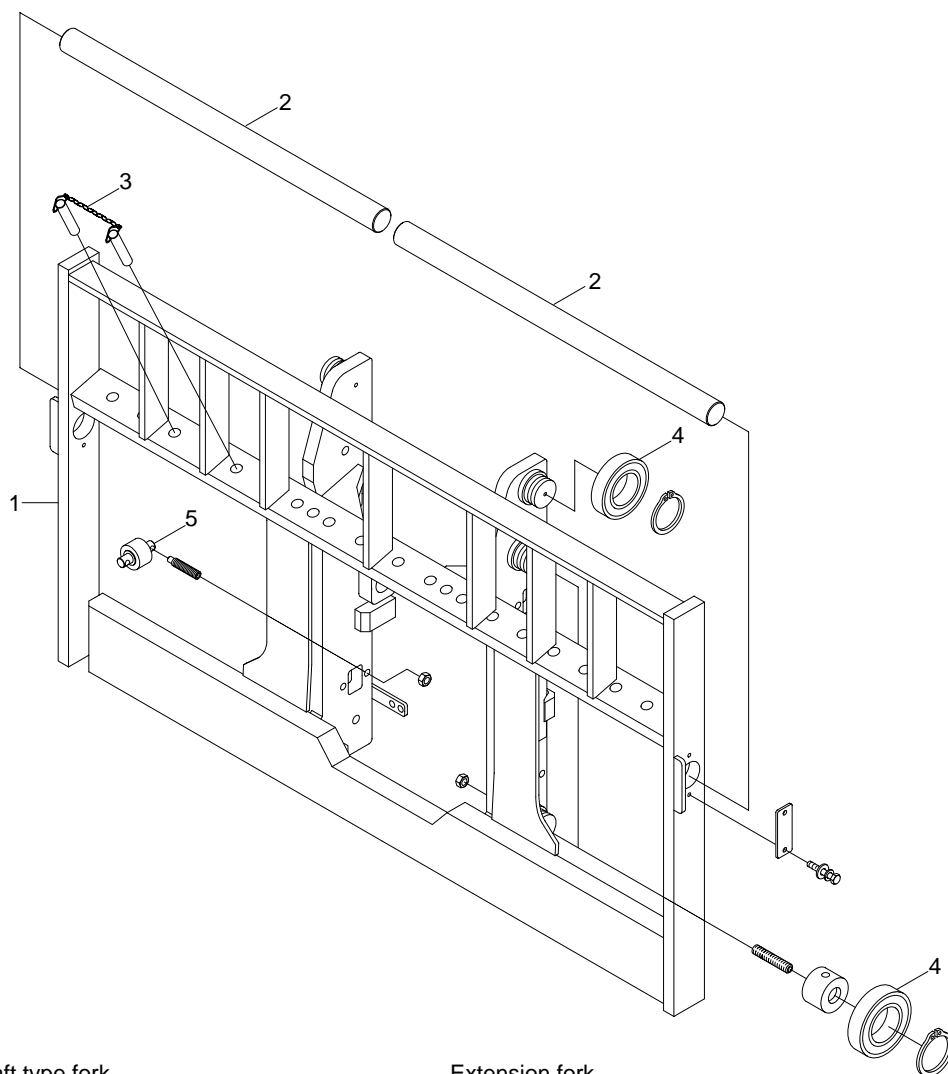

Shaft type fork

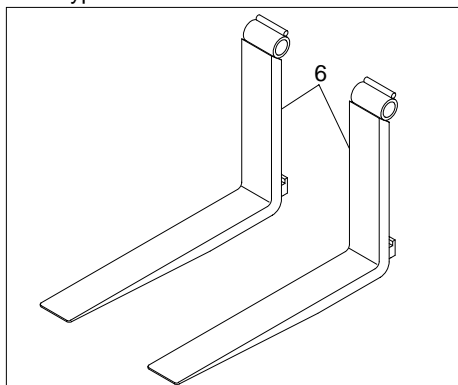

Extension fork

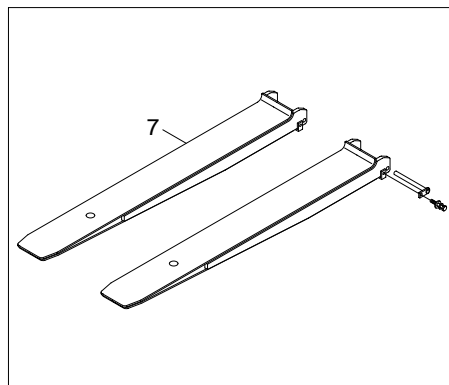

- 1 Carriage & backrest
- 2 Hanger bar
- 3 Fork retaining
- 4 Roller

- 5 Side roller
- 6 Fork
- 7 Extension fork

80D7MS02

GROUP 3 ADJUSTMENT

1. MAST LOAD ROLLER

1) INNER/OUTER MAST ROLLER CLEARANCE ADJUSTMENT

- (1) Measure the clearance with the mast overlap at near 480mm(19in).
- (2) Shift the inner mast to one side to bring the side roller into contact with the outer mast, and adjust the clearance between the end of inner beam and the outside of outer mast position on the opposite side to the following value by adjust bolt.
 - Reference clearance $A = 43.1\text{mm}$

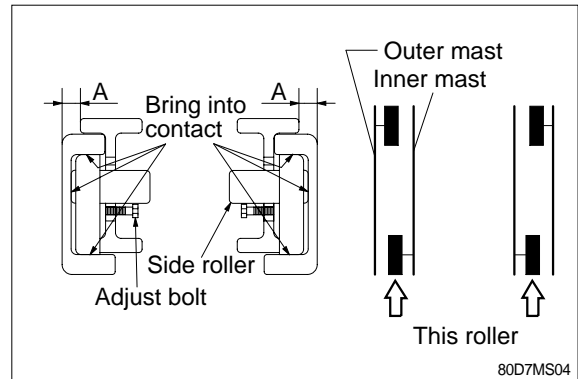

- (3) Distribute the clearance A equally to the left and right.
- (4) After the adjustment, check that the inner mast moves smoothly in the outer mast.

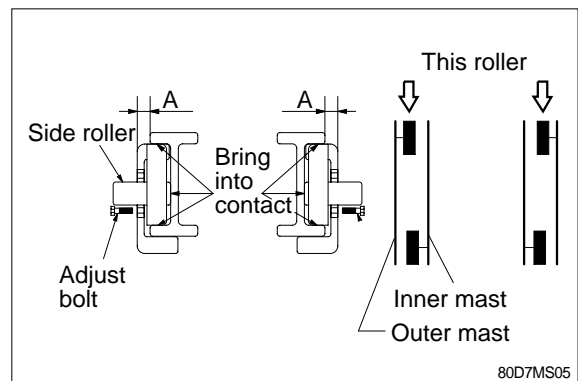

2) CARRIAGE LOAD ROLLER

- (1) Measure the clearance when the center of the carriage upper roller is 100mm from the top of the inner mast.
- (2) Measure the clearance at upper, middle and lower rollers after loosen the adjust screws from the side rollers. Shift the carriage to one side to bring the side roller into contact with the inner mast, and measure the clearance between inner face of the inner mast and carriage plate at the closest position on the opposite side to the following value by adjust screw.
 - Reference clearance B = 56.9mm
- (3) Distribute the clearance B equally to the left and right.
- (4) After the adjustment, the carriage should move smoothly along the overall mast length.

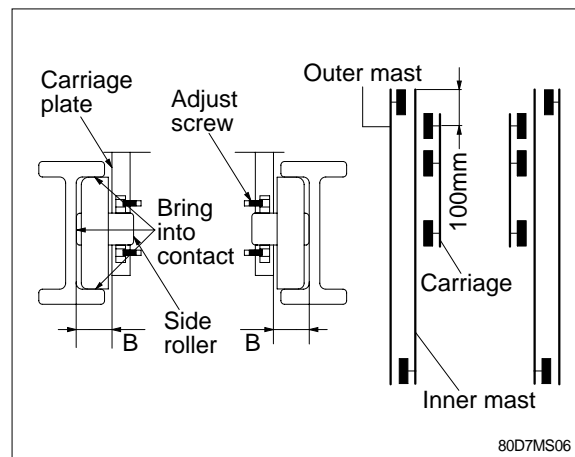

GROUP 4 REMOVAL AND INSTALLATION

1. FORKS

1) HOOK ON TYPE

- (1) Lower the fork carriage until the forks are approximately 25mm(1in) from the floor.
- (2) Release fork anchor pins and slide one fork at a time toward the center of the carriage where a notch has been cut in the bottom plate for easy fork removal.
- (3) Remove only one fork at a time.
 - ※ On larger forks it may be necessary to use a block of wood.
- (4) Reverse the above procedure to install load forks.

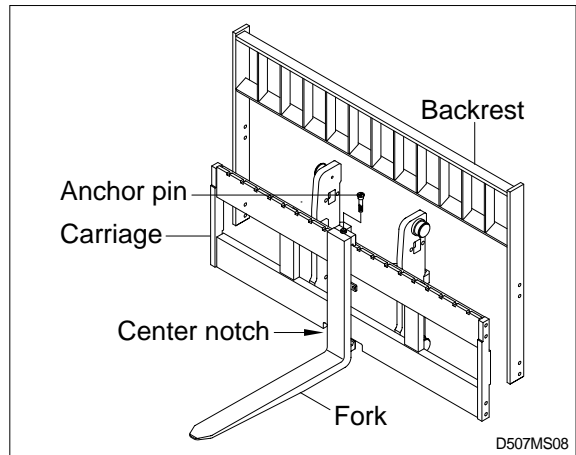

2) SHAFT TYPE(Option)

- (1) Lower the fork carriage until the forks are approximately 25mm(1in) from the floor.
- (2) Release fork retainer and remove cover.
- (3) Slide one hanger bar at a time out of carriage assembly.
- (4) Remove only one fork at a time.
 - ※ On larger forks it may be necessary to use a block of wood.
- (5) Reverse the above procedure to install load forks.

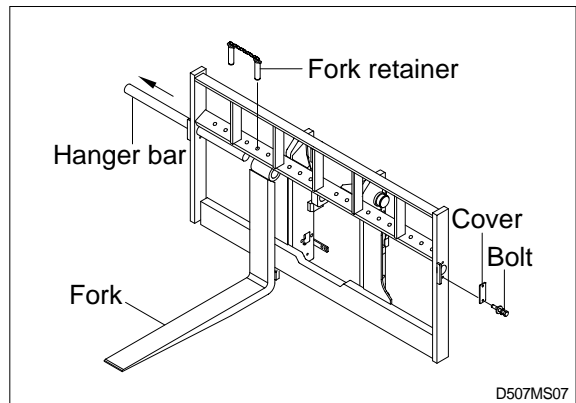

2. BACKREST(Hook on type)

- 1) Remove bolts securing backrest to fork carriage. Lift backrest straight up and remove from carriage.
- 2) Position backrest on carriage and lower in place. Install and tighten bolts.

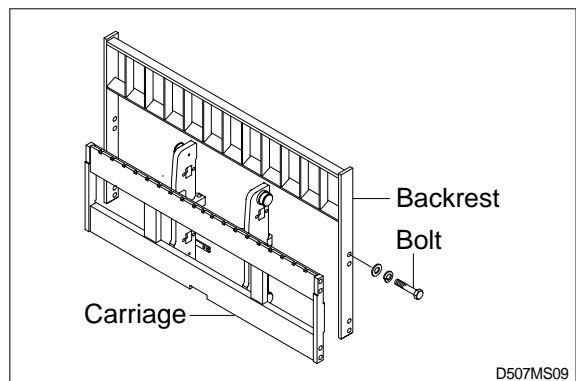

3. CARRIAGE ASSEMBLY

1) CARRIAGE

- (1) With the mast vertical, raise the carriage high enough to place blocks under the load forks. This is done to create slack in the load chains when the carriage is lowered. Lower the carriage all the way down to the floor. Make sure the carriage is level, this will prevent any binding when the mast is raised.
 - (2) While supporting lift chains, remove the split pin and slide out chain anchor pins from the chain anchors of stationary upright.
 - (3) Pull the chains out of the sheaves and drape them over the front of the carriage.
 - (4) Slowly raise inner mast upright until mast clears top of fork carriage. Move carriage to work area and lower mast.
- ※ Make sure carriage remains on floor and does not bind while mast is being raised.
- (5) Inspect all parts for wear or damage. Replace all worn or damaged parts.
 - (6) Reverse the above steps to reinstall.
- ※ Replace the split pin of chain anchor with new one.

2) SIDE ROLLER

- (1) Remove carriage as outlined in the carriage removal paragraph.
- (2) Loosen and remove nuts, adjust screws and side rollers from carriage side plate.
- (3) Thoroughly clean, inspect and replace all worn or damaged parts.
- (4) Reverse the above procedure to assembly.

※ **Adjustment**

- Once carriage is properly installed, loosen nuts and adjust screws, (if not already done) allowing carriage to be centered in the inner mast.
- Adjust side roller by tightening screw until side roller just makes contact with mast. Back off approximately 1/10 turn on screw and tighten nut to lock screw in place.
- Run carriage up and down along the inner mast to be sure the carriage has free movement and does not stick. Also, make sure chains are properly adjusted. Refer to chain adjustment paragraph. Make adjustment when necessary and recheck operation of carriage.

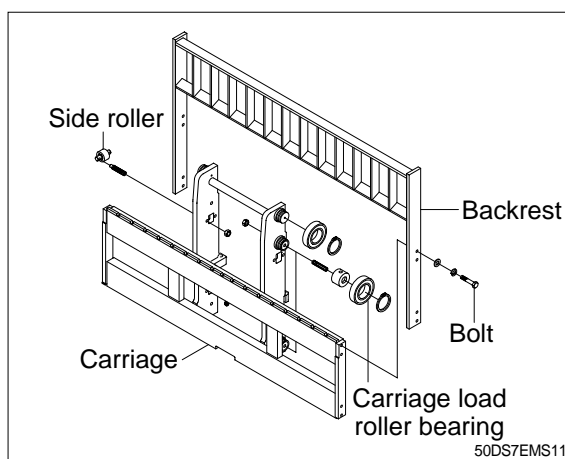
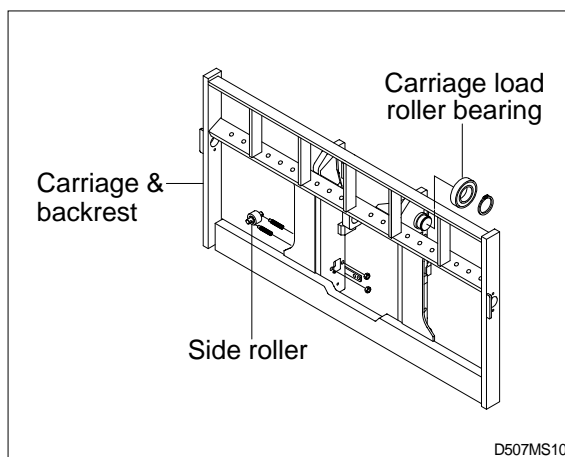

3) CARRIAGE LOAD ROLLER BEARING

- (1) Remove carriage as outlined in the carriage removal paragraph.
- (2) Using the plier, remove retaining rings from load roller bearing bracket.
- (3) Using a plier, remove load roller bearings from load roller bearing bracket.
- (4) Reverse the above procedure to assemble. Refer to MAST ROLLER ADJUSTMENT paragraph.

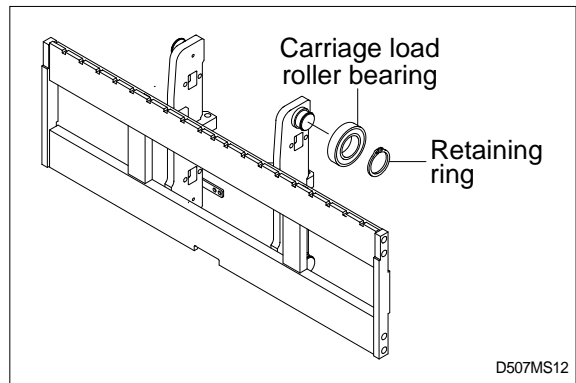

4. MAST LOAD ROLLER

1) 2 STAGE MAST(V MAST)

- (1) Remove the carriage assembly and move them to one side.
- (2) Loosen and remove hexagon nuts and screws securing lift cylinders to inner mast.
- (3) Loosen and remove hexagon bolts and nuts securing lift cylinders to outer mast.
- (4) Attach chains or sling to the inner mast section at top crossmember. Using an overhead hoist, slowly raise the inner mast high enough to clear lift cylinder.
- (5) After lowering the lift cylinder rods, and disconnecting lift cylinder hose, tilt the lift cylinders(LH and RH) with ropes to the outer mast.
- (6) Using the overhead hoist, lower inner mast until top and bottom rollers are exposed.
- (7) Using a plier, remove load rollers from load roller bracket. Remove side rollers.
- (8) Thoroughly clean, inspect and replace all worn or damaged parts.
- (9) Reverse the above procedure to assemble. Refer to MAST ROLLER ADJUSTMENT paragraph.
- (10) After completing all necessary steps for load rollers removal, use an overhead hoist to remove sling or chain around upper crossmember of the inner mast section. Lift inner mast upright straight up and out of outer mast section. Replace and reverse above procedure to
- (11) install.
- (12) Make all necessary measurements and adjustments.

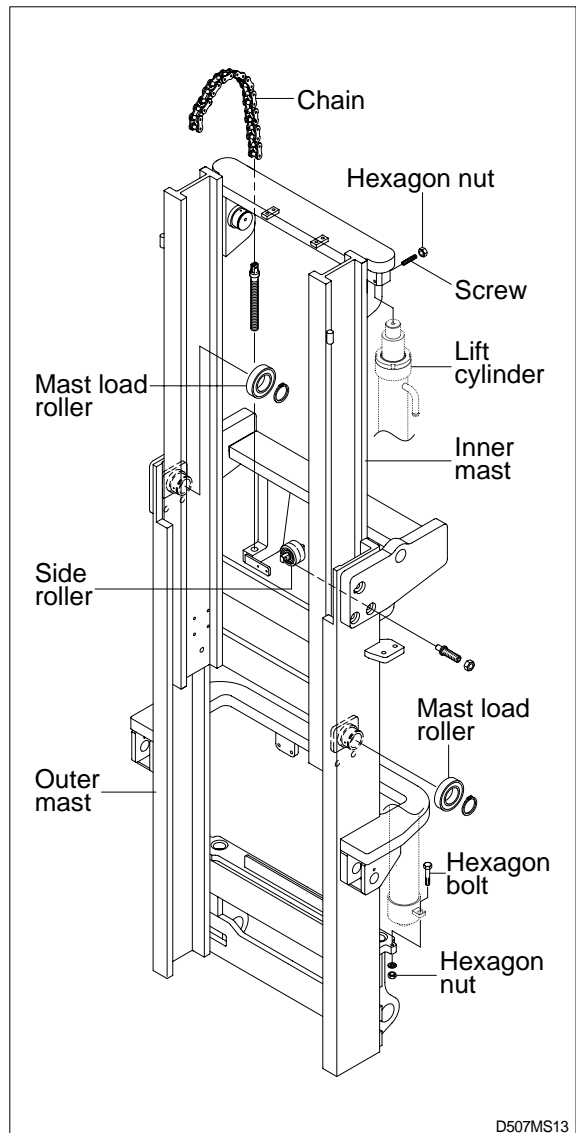

2) 3 STAGE MAST(TF MAST)

- (1) Remove the carriage assembly and move it to one side.
- (2) Loosen and remove hexagon bolt securing bottom cylinder from outer mast.
- (3) Loosen and remove set screws and nuts securing lift cylinders to middle mast.
- (4) Attach chains or sling to the inner and middle mast section at top crossmember. Using an overhead hoist, slowly raise the uprights high enough to clear lift cylinder.
- (5) After lowering the lift cylinder rods, and disconnecting lift cylinder hose, tilt the lift cylinders LH and RH and tie them with ropes to the outer mast.
- (6) Using the overhead hoist raise inner and middle masts. Place 4inch block of wood under the free lift cylinder bracket of the inner mast then lower mast sections(this will create slack in the chains).
- (7) Remove retaining rings securing chain sheaves to sheave support brackets while supporting chains, remove chain sheaves and let chains hang free. The upper outer and lower middle mast rollers and back up liners are now exposed.
- (8) Using a plier, remove load rollers from load bracket. Remove side rollers from mast.
- (9) Attach chains or sling to the middle mast section at top crossmember. Using an overhead hoist, slowly raise the middle mast until top and bottom rollers are exposed.
- (10) Using a plier, remove load rollers from roller bracket.
- (11) Thoroughly clean, inspect and replace all worn or damaged parts.
- (12) Reverse the above procedure to assemble. Refer to MAST LOAD ROLLER ADJUSTMENT Paragraph.

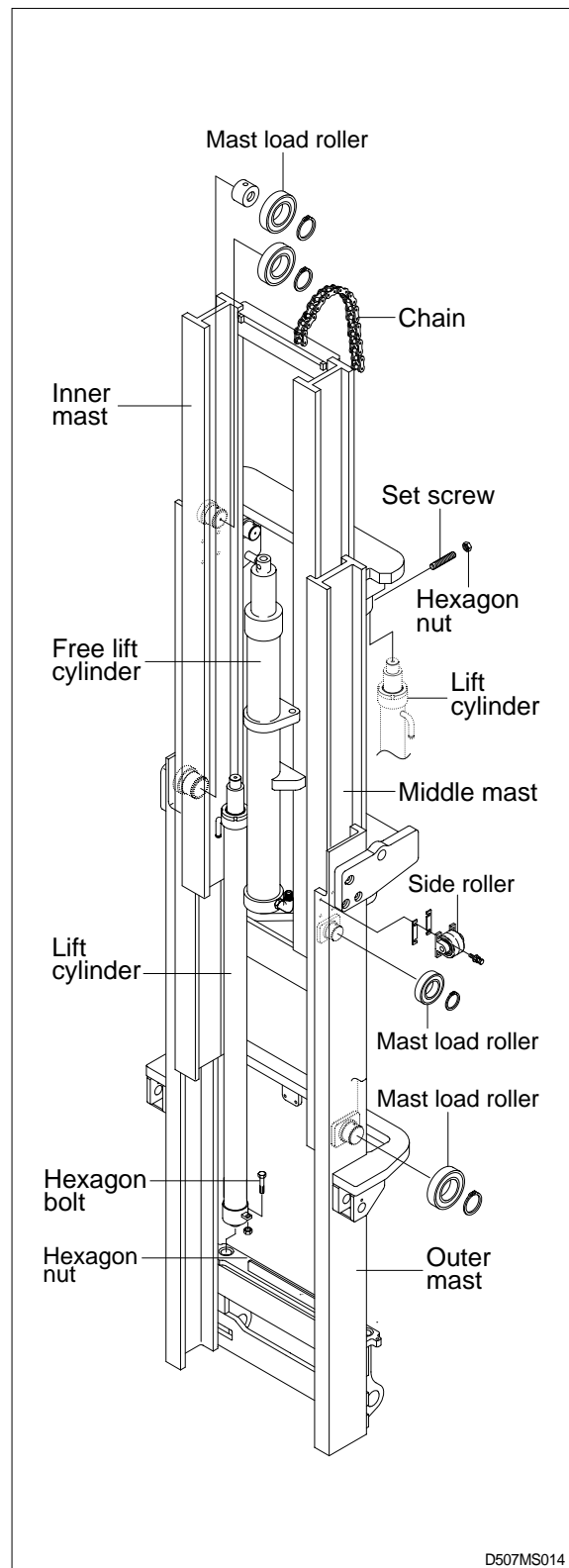

5. CHAIN

1) CHAIN SHEAVE

- (1) Place a sling around carriage and attach to an overhead hoist. Lift carriage high enough so that the tension on the chain over sheaves is relieved after the carriage is blocked. Position wooden blocks under the carriage and lower it.
- (2) Remove the split pin securing the chain anchor pins and discard. While supporting the chains, remove the chain anchor pins and drape the chain over the carriage.
- (3) Remove retaining ring securing sheaves to sheave support. Remove sheaves with bearings.
- (4) Remove bearing retaining ring from sheave and press bearings from sheaves.
- (5) Thoroughly clean, inspect and replace all worn or damaged parts.
- (6) Reverse the above to assemble and install. Use new split pins in chain anchor pins.

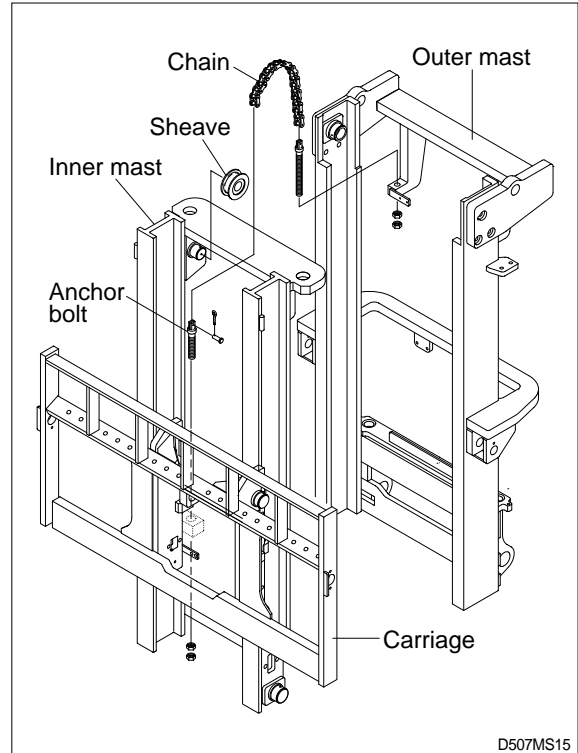

2) Rear chain sheave(TF mast)

- (1) Raise and securely block carriage and inner mast section.
- (2) Remove the split pin securing the chain anchor pins and discard.
- (3) Remove chains.
- (4) Remove retaining ring securing chain sheaves to sheave support. Pry off sheaves with bearings.
- (5) Remove bearing retaining ring from sheave and press bearings from sheaves.
- (6) Thoroughly clean, inspect and replace all worn or damaged parts.
- (7) Reverse the above procedure to assemble and install. Use new split pins in chain anchor pins.

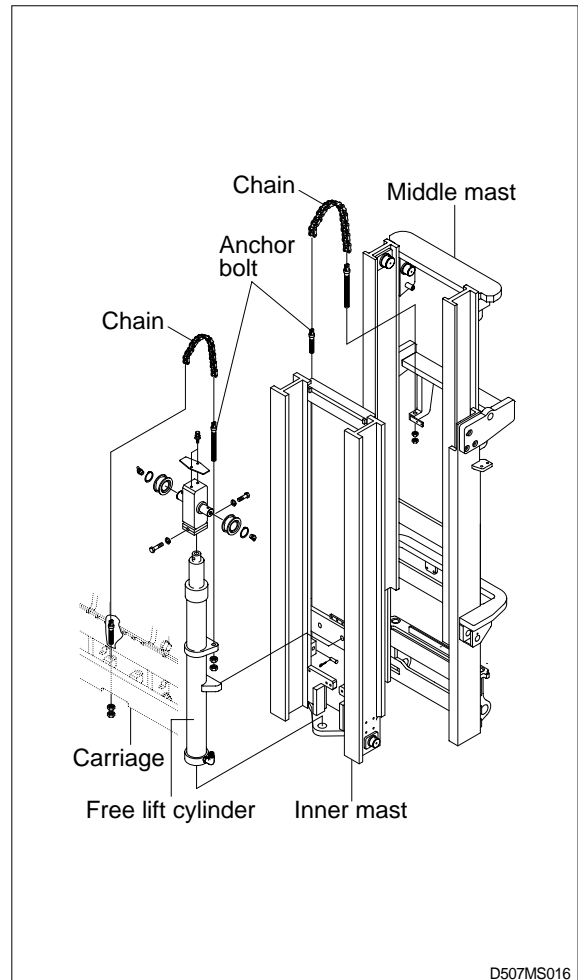

3) Sheave support(TF mast)

- (1) Remove the carriage assembly and move to one side.
- (2) After removing bolt to securing sheave support assembly to free lift cylinder.
Attach a sling to the sheave support assembly. Using an overhead hoist, lift support assembly straight up and off of free lift cylinder. Move assembly to work area.
- (3) Remove retaining ring securing sheave to sheave support.
- (4) Remove bearing retaining ring from sheave and press bearings from sheaves.
- (5) Thoroughly clean, inspect and replace all worn or damaged parts.
- (6) Reverse the above procedure to install.

4) Rear chain(TF mast)

- (1) Remove the carriage assembly and move to one side. Refer to carriage removal and installation.
- (2) Raise and securely block truck approximately 6 inches from the floor.
- (3) Using a sling or chain around inner mast section attached to an overhead hoist, slowly raise inner mast until there is enough slack in the chains to remove them. Block inner mast section.
- (4) Remove split pins and chain anchor pins securing chains to chain anchor(part of inner mast).
- (5) While supporting the chains, remove split and chain anchor pins securing chains to chain anchors attached to outer mast section.
- (6) Remove chains.
- (7) Reverse the above to assemble and install. Use new split pins in chain anchor pins. Refer to this section for Load chain lubrication and adjustment.

5) Carriage chain

- (1) Place a sling around carriage front plate and attach to an overhead hoist. Lift and secure carriage high enough so that split and chain anchor pins on carriage can be easily be removed. Remove chain anchor pins from carriage and drape chains out over carriage.
- (2) Place a wooden block under the carriage and lower the carriage on the block.
- (3) While supporting the chains, remove split pins and chain anchor pins from chain anchors.
- (4) Remove chains and wash them with solvent. Refer to this section for Load chain inspection and maintenance.
- (5) Reverse the above procedure to assemble and install. Use new split pins in chain anchor pins. Refer to this section for Load chain lubrication and adjustment.

6) Load chain inspection and maintenance

After every 200 hours of truck operation, lift chains should be inspected and lubricated inspect for the following chain conditions :

(1) Wear

As the chain flexes on and off the sheaves, the joints very gradually wear. The stretch a chain develops in service is due to material being worn off pin outer diameter and pitch hole inner diameter on the inside plate.

Chain wear can be measured using a wear scale or steel tape. When chains have elongated 2%, they should be discarded. When checking chain wear, be sure to measure a segment of chain that operates over a sheave. Do not repair chains by cutting out the worn section and splicing in a new piece. If part of the chain is worn, replace all the chains on the truck.

(2) Rust and corrosion

Chains used on lift trucks are highly stressed precision components. It is very important that the “as-manufactured” ultimate strength and fatigue strength be maintained throughout the chain service life. Corrosion will cause a major reduction in the load-carrying capacity of lift chain or roller chain because corrosion causes side plate cracking.

(3) Cracked plate

The most common cause of plate cracking is fatigue failure. Fatigue is a phenomenon that affects most metals and many plastics. After many repeated heavy loads, the plates may crack and the chains will eventually break. Fatigue cracks are almost always found through the pitch holes perpendicular to the pitch line. Contrast this failure mode to the random failures caused by stress-corrosion cracking. If cracks are present, replace all the chain on the truck. Noise in the chain indicates that the plate is on the verge of cracking and will be failed before long.

(4) Tight joints

All joints in lift chain should flex freely. Tight joints resist flexure, increase internal friction, thus increasing chain tension required to lift a given load. Increased tension accelerates wear and fatigue problems.

Tight joints in lift chains can be caused by :

- Bent pins or plates.
- Rusty joints.
- Peened plate edges.

Oil rusty chains and replace chains with bent or peened components.

(5) Protruding or turned pins

Heavily loaded chains operating with lube generate tremendous friction between pins and plates. In extreme cases, the frictional torque in the joint can actually turn pins in the press-fit outside plates. If chain is allowed to operate in this condition, the pins slowly work out of the chain causing chain failure. Turned pins can be quickly spotted because the flats on the V heads are no longer in line. Chains with turned or protruding pins should be replaced immediately. Do not attempt to repair the chain by driving pins back into the chain.

(6) Chain side wear

A wear pattern on pin heads and outside plates indicates misalignment. This condition damages chain and sheaves as well as increasing internal friction in the chain system.

(7) Chain anchors and sheaves

An inspection of the chain system includes a close examination of chain anchors and sheaves. Check chain anchors for wear, breakage and misalignment. Anchors with worn or broken fingers should be replaced. Anchors should be adjusted to eliminate twisting or other misalignment in the chain. When chain is misaligned, load is not distributed uniformly between the plates. Prolonged operation will result in premature fatigue failure. Sheaves with badly worn flanges and outside diameter should be replaced. Heavy flange wear indicates chain misalignment.

(8) Chain wear scale

The chain can be checked for wear or stretching with the use of a chain wear scale. Stretching of a chain is due to the elongation of the pitch holes and wearing of the pin O.D. The greatest amount of stretching occurs at the areas of the chain that flex over the sheaves most frequently. Check the chain at this point with a scale. The wear scale has instructions printed on the sides for use in determining chain stretch and are as follows :

- Determine pitch length of chain using 6 inch scale on one side of wear scale.
- If pitch is 1/2(12.7mm), 3/4(19.05mm), 1(25.4mm), 1-1/2(38.1mm), 2(50.8mm), use side A of scale.
- If pitch is 5/8(15.875mm), 1-1/4(31.75mm) or 2(50.8mm), use side B.
- Align point A or B to center of a pin and note position of the opposite A or B point.
- If other point also lines up with a pin, the chain is worn and should be replaced.

If any of the above conditions exists(cracked plates, turned pins, stretching etc), the chains should be replaced in pairs as a complete assembly. Order chains by part number to insure the correct chain length, pitch and material specifications.

7) Load chain lubrication and adjustment

(1) Lubrication

The most important consideration in field maintenance of lift chains is lubrication. Hard working, heavily loaded chains cannot be expected to give satisfactory wear life without scheduled periodic re-lubrication. Like all bearing surfaces, the precision manufactured, hardened steel, joint-wearing surfaces require a film of oil between mating parts to prevent rapid wear. Oil must penetrate the chain joint to prevent wear. Applying oil to external surfaces will prevent rust, but oil must flow into the live bearing surfaces for maximum wear life. Frequency of re-lube will vary with operating conditions and environment, the best estimate of lube period is 200 hours. Trucks parked outdoors or trucks in extremely severe service, may require more frequent re-lube to maintain an oil film on all chain surface.

- Wipe off the old oil with a clean cloth and blow out the remaining dirt with compressed air.

▲ Wear eye protection.

- With a clean brush, apply EP-140 extreme pressure lubricant or heavy motor oil(40W).

(2) Replacement

Replace chains as a pair. It will be virtually impossible to maintain uniform loading between the strands if a new chain is put into service opposite an old chain. The joints in the old chain will be greater than that on the new chain, greatly complicating the problem of maintaining equal chain tension. The new chain will wear more slowly causing it to bear the major portion of the load resulting in premature wear and fatigue failure. Don't steam clean or decrease new chains.

The manufacturer's grease is effective in reducing wear and corrosion. If the original factory lube is dried out or wiped off, soak the new chain in heavy engine oil for at 1/2 hour prior to installing on truck. After the old chains have been stripped from the mast, very carefully inspect chain anchors and sheaves. Broken, cracked or worn anchor must be replaced using the new anchor pin and split pin. Do not paint newly replaced chain after it has been installed.

(3) Adjustment

Chain adjustments are important for the following reasons :

- Equal loading of chain.
- Proper sequencing of mast.
- Prevent over-stretching of chains.
- Prevent chains from jumping off sheaves if they are too loose.

(4) Adjustment procedure

- With mast in its fully collapsed and vertical position, lower the fork to the floor.
- Adjust the chain length by loosening or tightening nut on the chain anchor.
After making adjustment on the mast, be sure to tighten the nut.