

FORKLIFT TRUCK

OPERATOR'S MANUAL

HBF15/18T-5

HBF20/25/30/32-7

HBF20/25/30C-7

20BH/25BH/30BH-7

MANUAL

A MESSAGE TO HYUNDAI LIFT-TRUCK OPERATORS

Lift trucks are specialized machines with unique operating characteristics, designed to perform a specific job. Their function and operation is not like a car or ordinary truck. They require specific instructions and rules for safe operation and maintenance.

Safe operation of lift trucks is of primary importance to HYUNDAI.

Our experience with lift truck accidents has shown that when accidents happen and people are killed or injured, the causes are:

- Operator not properly trained
- Operator not experienced with lift truck operation
- Basic safety rules not followed
- Lift truck not maintained in safe operating condition

For these reasons, HYUNDAI wants you to know about the safe operation and correct maintenance of your lift truck.

This manual is designed to help you operate your lift truck safely.

This manual shows and tells you about safety inspections and the important general safety rules and hazards of lift truck operation. It describes the special components and features of the truck and explains their function. The correct operating procedures are shown and explained. Illustrations and important safety messages are included for clear understanding. A section on maintenance and lubrication is included for the lift truck mechanic.

The operator's manual is not a training manual. It is a guide to help trained and authorized operators safely operate their lift truck by emphasizing and illustrating the correct procedures. However, it cannot cover every possible situation that may result in an accident. You must watch for hazards in your work area and avoid or correct them. It is important that you know and understand the information in this manual and that you know and follow your company safety rules!

Be sure that your equipment is maintained in a safe condition. Do not operate a damaged or malfunctioning truck. Practice safe operation every time you use your lift truck. Let's join together to set high standards in safety.

Remember, before you start operating this lift truck, be sure you understand all driving procedures. It is your responsibility, and it is important to you and your family, to operate your lift truck safely and efficiently.

△ Be aware that the Federal Occupational Safety and Health Act(OSHA) and state laws require that operators be completely trained in the safe operation of lift trucks; It is also an (OSHA) requirement that a machine inspection be performed before every shift. If you need training in operating or inspecting your lift truck, ask your supervisor.

HYUNDAI lift trucks are built to take hard work, but not abuse. They are built to be dependable, but they are only as safe and efficient as the operator and the persons responsible for maintaining them. Do not make any repairs to this truck unless you have been trained in safe lift truck repair procedures and are authorized by your employer.

This manual describes procedures for operation, handling, lubrication, maintenance, checking and adjustment. It will help the operator realize peak performance through effective, economical and safe machine operation.

INTRODUCTION

HYUNDAI welcomes you to the growing group of professionals who own, operate and maintain HYUNDAI lift trucks. We take pride in the long tradition of quality products and superior value the HYUNDAI name represents. This manual familiarizes you with safety, operating, and maintenance information about your new lift truck. It has been specially prepared to help you use and maintain your HYUNDAI lift truck in a safe and correct manner.

Your HYUNDAI lift truck has been designed and built to be as safe and efficient as today's technology can make it. As manufactured, for some models, it meets all the applicable mandatory requirements of ANSI H56.1-1988 Safety Standard for Powered Industrial Trucks. Some trucks are also furnished with equipment to help you operate safely, for example, load back rest, parking brake and horn are standard equipment.

Safe, productive operation of a lift truck requires both skill and knowledge on the part of the operator. The operator must know, understand, and practice the safety rules and safe driving and load handling techniques described in this manual. To develop the skill required, the operator must become familiar with the construction and features of the lift truck and how they function, the operator must understand its capabilities and limitations, and see that it is kept in a safe condition.

Routine Servicing and Maintenance

Regular maintenance and care of your lift truck is not only important for economy and utilization reasons; it is essential for your safety. A faulty lift truck is a potential source of danger to the operator, and to other personnel working near it. As with all quality equipment, keep your lift truck in good operating condition by following the recommended schedule of maintenance.

Operator Daily Inspection - Safety and Operating Checks

A lift truck should always be examined by the operator, before driving, to be sure it is safe to operate. The importance of this procedure is emphasized in this manual with a brief illustrated review and later with more detailed instructions. HYUNDAI dealers can supply copies of a helpful **Drivers Daily Checklist**. It is an OSHA requirement.

Planned Maintenance

In addition to the daily operator inspection, HYUNDAI recommends that a planned maintenance and safety inspection program (PM) be performed by a trained and authorized mechanic on a regular basis.

The PM will provide an opportunity to make a thorough inspection of the safety and operating condition of your lift truck. Necessary adjustments and repairs can be done during the PM, which will increase the life of components and reduce unscheduled downtime and increase safety. The PM can be scheduled to meet your particular application and lift truck usage.

The procedures for a periodic planned maintenance program that covers inspections, operational checks, cleaning, lubrication, and minor adjustments are outlined in this manual. Your HYUNDAI dealer is prepared to help you with a Planned Maintenance Program by trained service personnel who know your lift truck and can keep it operating safely and efficiently.

Service Manual

In-depth service information for trained service personnel is found in Service Manual.

HOW TO USE THIS MANUAL

This manual is a digest of essential information about the safe operation, the features and functions and explains how to maintain your lift truck. This manual is organized into eight major parts:

Section 1. General Safety Rules, reviews and illustrates accepted practices for safe operation of a lift truck.

Section 2. Operating Hazards, warns of conditions that could cause damage to the truck or injury to the operator or other personnel.

Section 3. Know Your Truck, describes the major operating components, systems, controls, and other features of your truck and tells how they function.

Section 4. Daily Safety Inspection, presents details on how to perform the operator's daily safety inspection and retest the lift truck.

Section 5. Operating Procedures, discusses specific instructions on the safe, efficient operation of your lift truck.

Section 6. Emergency Towing, gives instructions for towing your truck in an emergency and for using battery jumper cables to start your truck in an emergency.

Section 7. Planned Maintenance, describes the PM (Planned Maintenance) program.

Section 8. Specifications, provides reference information and data on features, components, and maintenance items.

*The descriptions and specifications included in this manual were in effect at the time of printing. HYUNDAI reserves the right to make improvements and changes in specifications or design, without notice and without incurring obligation. Please check with your authorized HYUNDAI dealer for information on possible updates or revisions.

The examples, illustrations, and explanations in this manual should help you improve your skill and knowledge as a professional lift truck operator and take full advantage of the capabilities and safety features of your new lift truck.

The first section of the manual is devoted to a review, with illustrations and brief messages, of general safety rules and the major operating hazards you can encounter while operating a lift truck. Next, you will find descriptions of the components of your specific lift truck model and how the instruments, gauges, and controls operate. Then, you will find a discussion of safe and efficient operating procedures, followed by instructions on how to tow a disabled lift truck. The later sections of the manual are devoted to maintenance and truck specifications.

Take time to carefully read the **Know Your Truck** section. By acquiring a good basic understanding of your truck's features, and how they function, you are better prepared to operate it both efficiently and safely.

In **Planned Maintenance**, you will find essential information for correct servicing and periodic maintenance of your truck, including charts with recommended maintenance intervals and component capacities. Carefully follow these instructions and procedures.

Each major section has its own table of contents, so that you can find the various topics more easily.

We urge you to first carefully read the manual from cover to cover. Take time to read and understand the information on general safety rules and operating hazards. Acquaint yourself with the various procedures in this manual. Understand how all gauges, indicator lights, and controls function. Please contact your authorized HYUNDAI dealer for the answers to any questions you may have about your lift truck's features, operation, or manuals.

Operate your lift truck safely; careful driving is your responsibility.

Drive defensively and think about the safety of people who are working nearby. Know your truck's capacities and limitations. Follow all instructions in this manual, including all symbols (▲ △ ⊗) messages to avoid damage to your lift truck or the possibility of any harm to yourself or others.

This manual is intended to be a permanently attached part of your lift truck. Keep it on the truck as a ready reference for anyone who may drive or service it. If the truck you operate is not equipped with a manual, ask your supervisor to obtain one and have it attached to the truck. And, remember, your HYUNDAI dealer is pleased to answer any questions about the operation and maintenance of your lift truck and will provide you with additional information should you require it.

1. DIRECTION:

The direction of this machine indicate forward, backward, right and left when machine is in the travelling direction.

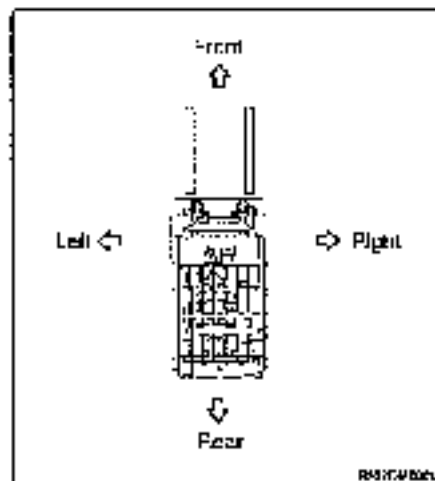
**2. SERIAL NUMBER:**

Inform following when you order parts or the machine is out of order.

1) MACHINE SERIAL NUMBER

It's shown on the front right side of the frame.

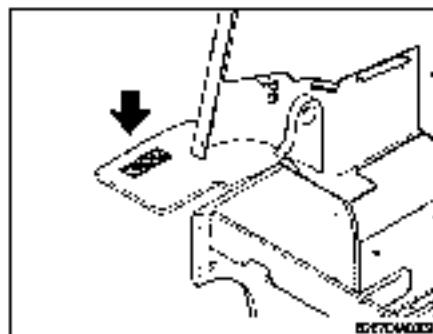
**3. SYMBOLS:**

▲ Important safety hint.

△ It indicates matters which can cause the great loss on the machine or the surroundings.

≡ It indicates the useful information for operator.

1. GENERAL SAFETY RULES

1. Daily inspection	1-1
2. Do's and don'ts	1-2
3. Seat belts	1-3
4. No riders	1-4
5. Pedestrians	1-5
6. Operator protection	1-6
7. Fork safety	1-7
8. Pinch points	1-8
9. Travel	1-9
10. Grades, ramps, slopes and inclines	1-10
11. Tip over	1-11
12. Surface and capacity	1-13
13. Parking	1-14
14. Lifting, jacking and blocking	1-15

2. OPERATING HAZARDS

1. Loose loads	2-1
2. Long and wide loads	2-2
3. Rear swing	2-2
4. Low overhead clearance	2-3
5. Fast turns and high loads	2-3
6. Drop-offs	2-4
7. Right-angle stacking	2-4
8. Chain slack	2-5
9. Pallets and skids	2-5
10. Caution for electrical lines	2-6

3. KNOW YOUR TRUCK

1. General locations	3-1
2. Data/safety plates and decals	3-3
3. Instruments and controls	3-6
4. Instruments panel	3-8
5. Indicator symbols	3-9
6. Operating switches and levers	3-12

7. Seat adjustment	3-14
8. Battery compartment access	3-14
4. DAILY SAFETY INSPECTION	
1. Inspecting your truck	4-1
2. Visual checks	4-2
3. Functional checks	4-3
4. Concluding the inspection	4-3
5. OPERATING PROCEDURES	
1. Before operating the truck	5-1
2. Starting from a safe condition	5-1
3. Adjusting the seat	5-2
4. Starting the truck	5-3
5. Controlling Speed	5-5
6. Braking	5-5
7. Plugging	5-5
8. Operating safely	5-6
9. Load handling	5-8
10. Shut down procedure	5-13
6. EMERGENCY TOWING	
1. Towing precautions	6-1
2. Towing procedures	6-2
7. PLANNED MAINTENANCE	
1. Introduction	7-1
2. Lift truck maintenance	7-1
3. Planned maintenance	7-1
4. Planned maintenance intervals	7-2
5. Major component locations	7-3
6. Daily maintenance checks	7-5
7. Periodic maintenance checks	7-6
8. Safe maintenance practices	7-7
9. Maintenance guide	7-9
10. Visual inspection	7-13
11. Checking the hydraulic fluid	7-16
12. Critical fastener checks	7-16
13. Air cleaning the truck	7-17

14. Electric truck battery maintenance	7-18
15. Battery handling	7-19
16. Battery charging	7-20
17. Battery removal from truck	7-22
18. Battery cleaning and care	7-24
19. Controller system	7-25
20. New machine oil	7-63
21. Recommended lubricants	7-63

8. SPECIFICATIONS

1. Specification table	8-1
2. Specification for major components	8-6
3. Tightening torque	8-14

1. GENERAL SAFETY RULES

1. DAILY INSPECTION

At the beginning of each shift, inspect your battery tractor and fill out a check, maintenance and lubrication table.

Check for damage and maintenance problems.

Have repairs made before you operate the battery tractor.

Do not make repairs yourself. Lift truck mechanics are trained professionals. They know how to make repairs safe.



2: DO'S AND DON'TS



Do watch for pedestrians.



Do wear safety equipment when required.



Don't mix drugs or alcohol with your job.



Don't block safety or emergency equipment.



Don't smoke in NO SMOKING areas or when charging.

3 SEAT BELTS

⚠ Always buckle up for the machine equipped with safety belt.

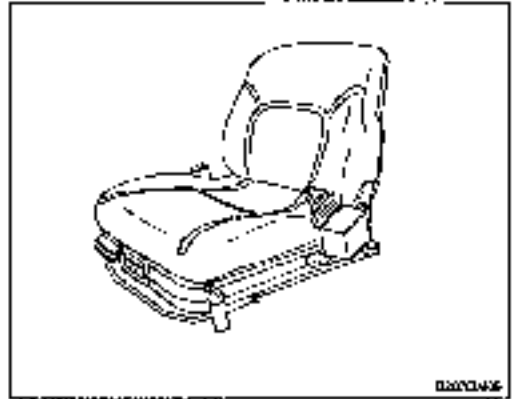

⚠ Seat belts can reduce injuries.

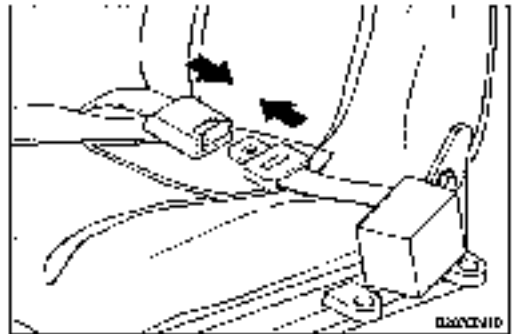

4. NO RIDERS

- 1) The operator is the only one who should be on a truck.

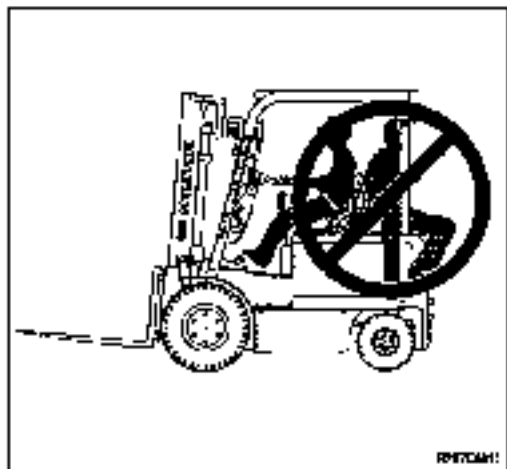

- 2) Never transport personnel on the forks of a lift truck.

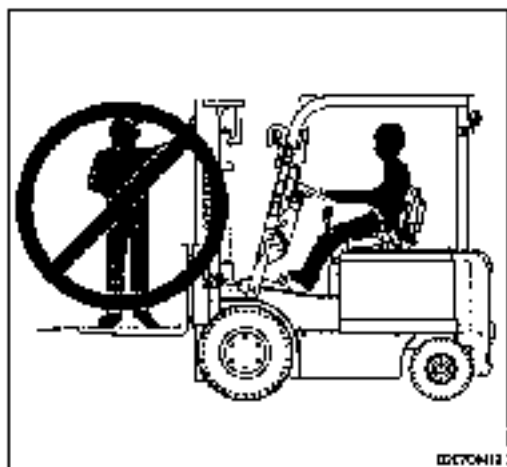

5. PEDESTRIANS

- 1) Watch where you are going. Look in the direction of travel. Pedestrians may use the same roadway you do. Sound your horn at all intersections or blind spots.

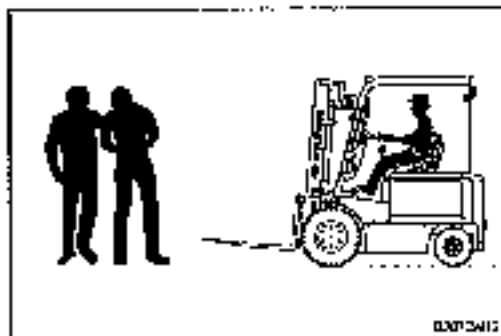

- 2) Watch for people in your work area even if your battery tractor has warning lights or alarms. People may not watch for you.



- 3) Make people stand back, even when you are parked.

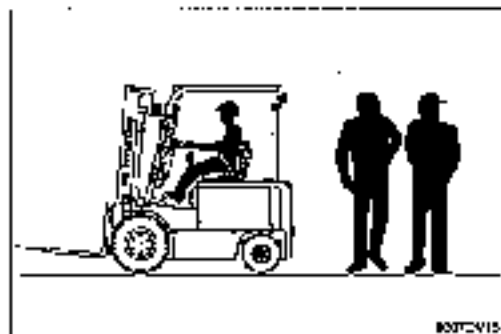

6. OPERATOR PROTECTION

- 1) Keep under the overhead guard.
- 2) Always keep your body within the confines of the truck.

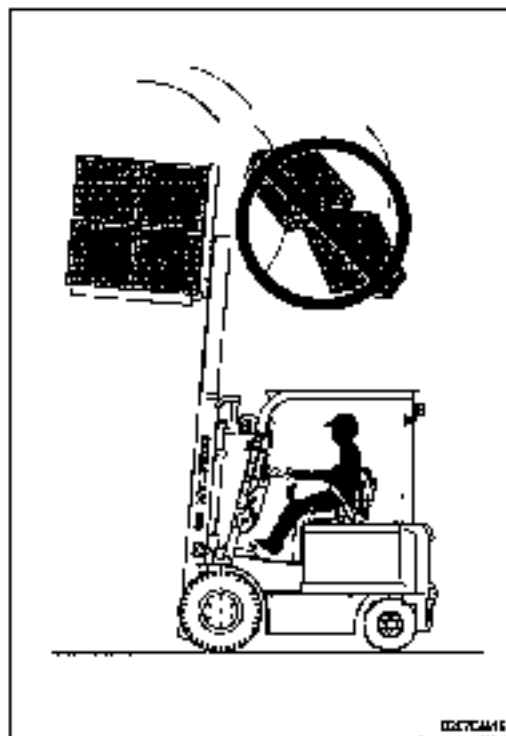

7. FORK SAFETY

Never allow anyone to walk under raised forks.

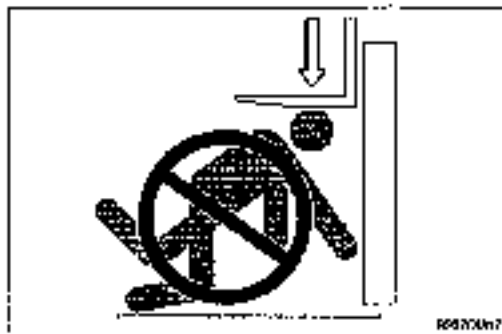

There is special equipment to raise people for overhead work.
DO NOT USE LIFT TRUCKS.

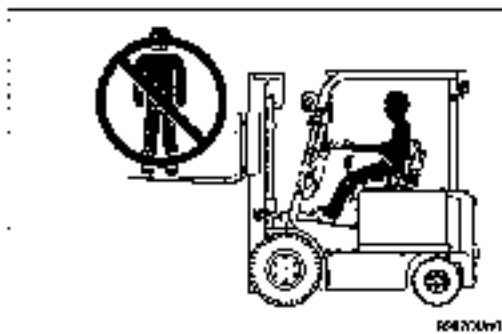

8. PINCH POINTS

⚠ Keep hands, feet and legs out of the mast.



⚠ Don't use the mast as a ladder.

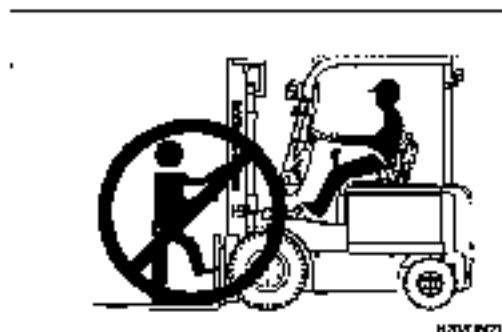

⚠ Never try to repair the mast, carriage, chain, or attachment yourself. Always get a trained mechanic.

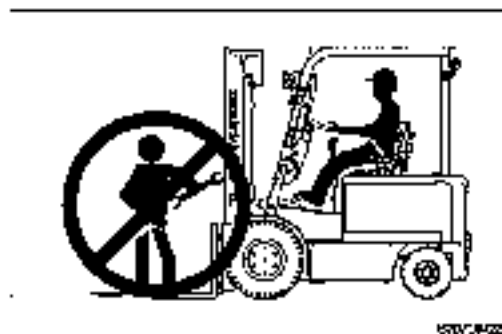

9 TRAVEL

1) Travel with the load near the floor/ground with mast tilted back to cradle the load whenever possible.

⚠ Never lift or lower the load when the truck is in motion.

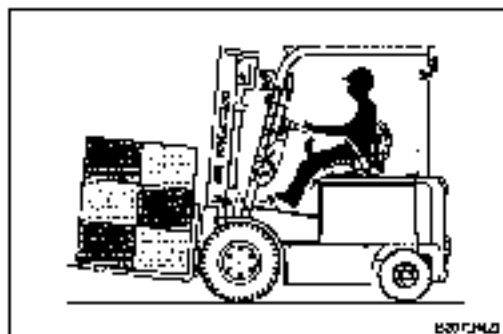

2) When handling bulky loads that restrict your vision operate your truck in reverse to improve visibility. Be sure to pivot in the seat to give maximum visibility.

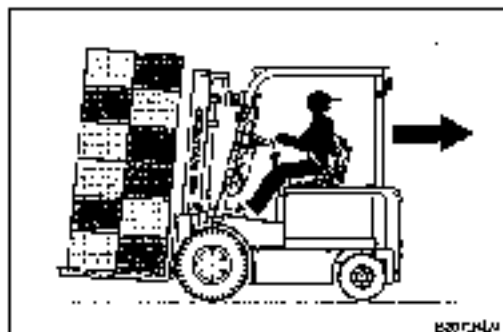

3) Unstable loads are a hazard to you and to your fellow workers. Always make certain that the load is well stacked and evenly positioned across both forks. Never attempt to lift a load with only one fork.

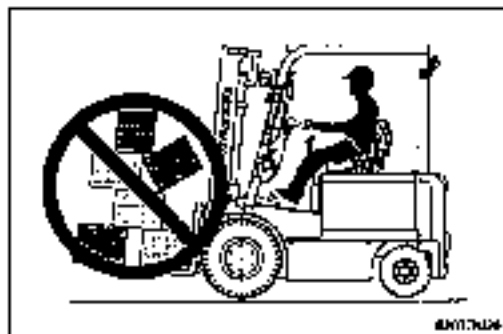

10. GRADES, RAMPS, SLOPES AND INCLINES

⚠ Never turn on a grade, either loaded or unloaded.

1) UNLOADED - Forks downgrade

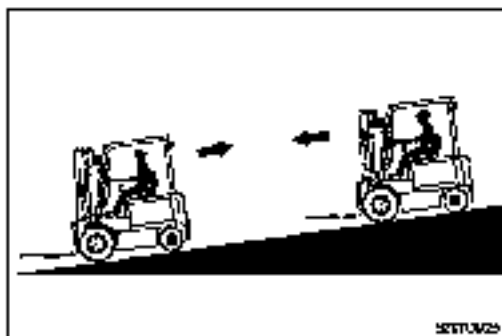

2) LOADED - Forks upgrade

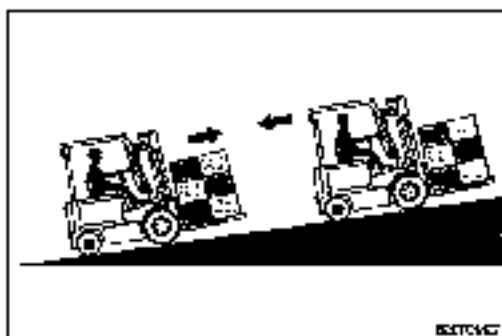

1.1: TIP OVER

1) LATERAL TIP OVER

- (1) Lateral tip over can occur with a combination of speed and sharpness of turn. This combination will exceed the stability of the truck. This condition is even more likely with an unladen truck.
- (2) With the load or mast raised, lateral tip over can occur while turning and/or braking when traveling in reverse or accelerating and turning while traveling forward.
- (3) Lateral tip over can occur loaded or unloaded by turning on an incline or ramp.

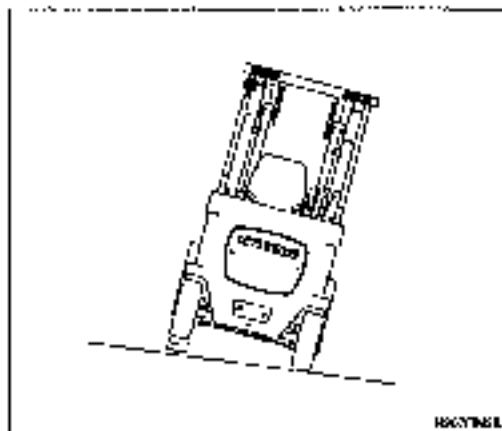

2) LONGITUDINAL TIP OVER

- (1) Longitudinal tip over can occur with combination of overloading and load elevated also with capacity load and elevated. This combination will exceed the stability of the truck. This condition is even more likely with excessive forward tilt, braking in forward travel or accelerating rearward.
- (2) Longitudinal tip over can occur by driving with the load down slope on a steep grade.

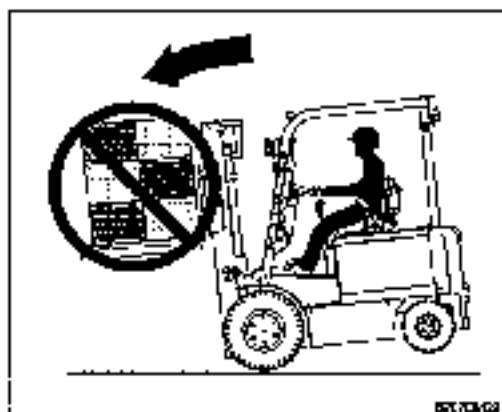

Lateral and longitudinal tip over can occur if the truck is driven over objects on the floor or ground, off the edge of improved surfaces, or into potholes in the road surface, or by running into overhead objects or collisions.

An off dock type of tip over can occur if the truck is steered too close to the dock edge, driven off the edge of the dock or ramp, or if the highway truck or trailer rolls away from the dock or is driven away during loading.

- ⚠ The conditions listed above can be further aggravated by overloading, excessive tilt, or off center loads.
- ⚠ Lift truck tip over can cause serious injury or death if the operator is trapped between the truck and the ground.

3 WHAT TO DO IN CASE OF A TIP OVER

⚠ If your truck starts to tip over, Do not jump.

⚠ Brace yourself as illustrated right.

1. Make sure your seat belt is fastened securely, if the truck is equipped with seat belt.
2. Stay in your seat.
3. Grip the wheel.
4. Brace your feet.

⚠ Your chances for survival in a tip-over are better if you stay with the truck, in your seat.

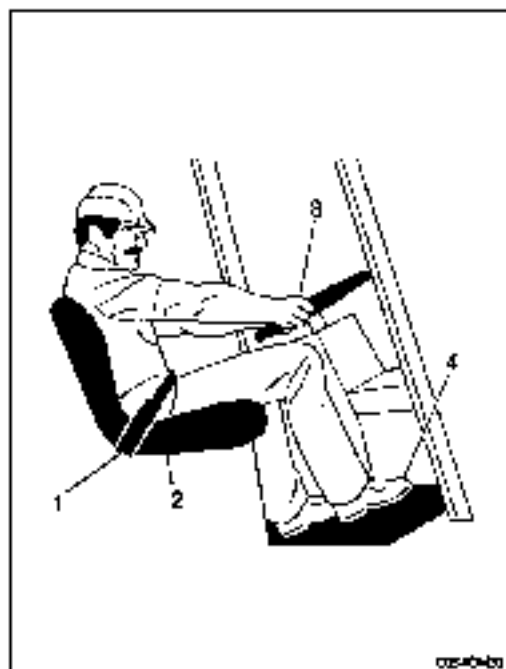

12. SURFACE AND CAPACITY

Avoid these conditions. They can cause a truck to tip over or lose traction for braking or driving.

- ▲ Know the weight of your truck and load. Especially when using elevators, Know the capacity of the elevator you intend to use. Do not overload.

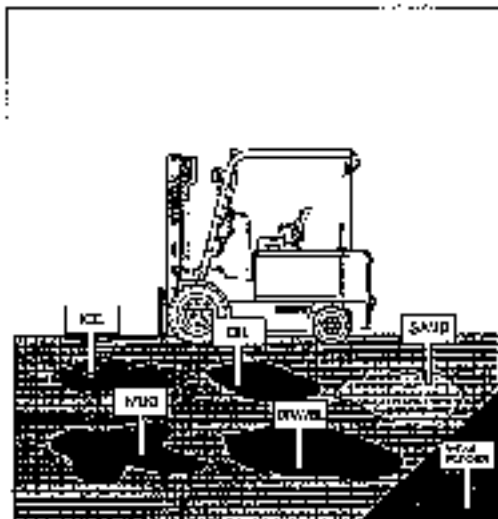

BMW/DAF

TIP OVER

- ▲ Seat belts can reduce injuries. ALWAYS BUCKLE UP

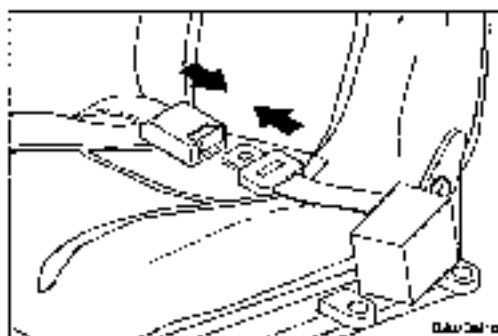

BMW/DAF

13 PARKING

1) Never park on a grade.

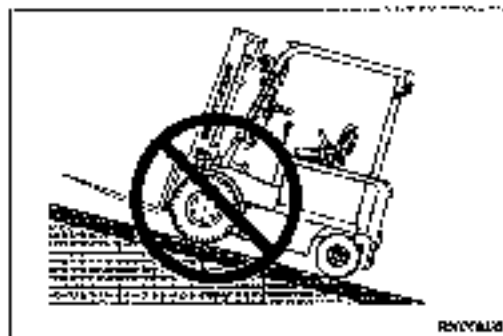

2) Always come to a complete stop before leaving truck. Be sure travel control is in NEUTRAL.

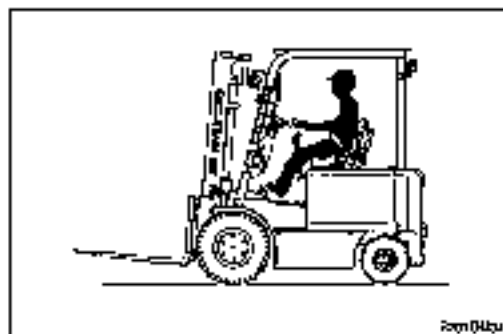

3) Lower forks fully to floor and tilt forward.

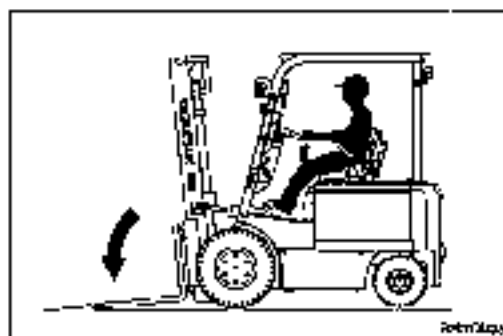

4) Set parking brake.

Position ① : Lock

Position ② : Release

5) Turn key to OFF position.

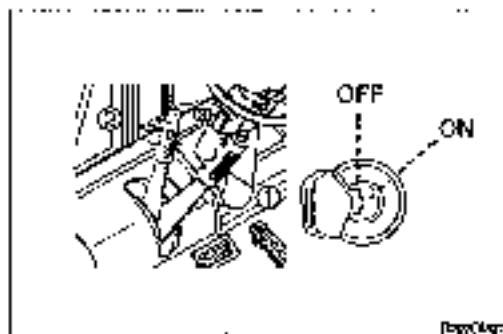

14. LIFTING, JACKING AND BLOCKING

▲ Lifting or jacking any large piece of equipment such as forklift truck presents obvious hazards. It must be done with great care and forethought.

1) SAFE PARKING

Before working on truck:

- (1) Park truck on a hard, level and solid surface, such as a concrete floor with no gaps or breaks.
- (2) Put mast in vertical position and fully lower the forks or attachment.
- (3) Put all controls in neutral. Turn key switch OFF and remove key.
- (4) Apply the parking brake and block the wheel.

▲ Defective equipment can cause accidents. All tools and lifting equipment must be in good condition, meet the load capacity requirements and have OSHA labels when required. Tools with defects and have failures causing severe injury or death.

2) LIFTING, BLOCKING AND JACKING POINTS

Use the following illustration to locate general lifting, blocking and jacking points on the truck. Read the procedures for raising, blocking or jacking specific components of the truck to make sure you understand the correct, safe procedures.

▲ Do not attempt to lift the truck by the overhead guard or the counterweight. Severe injury may result and the truck can be damaged.

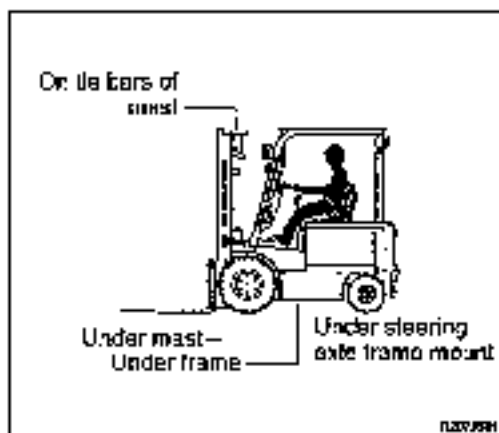

3) RAISING DRIVE WHEELS OFF FLOOR

This procedure uses the mast as a lever to lift the drive wheels off the floor and prevent accidents due to inadvertent powering of the drive wheels.

- (1) Park truck safely as described in "Safe Parking". Block rear steer wheels.
- (2) Be sure mast trunion bolts are tight. Bolt torque must be 7.5 8.0kg · m (55 59 lb · ft).
- (3) Start the engine. Tilt the mast fully back. Adjust upright height as necessary to put blocking underneath the lower end of the mast.
- (4) Put a solid 100mm (4.4in) hardwood block under the front section of each mast rail. Put a 3-6mm (1/25--2/50 in) steel plate on top of each block.

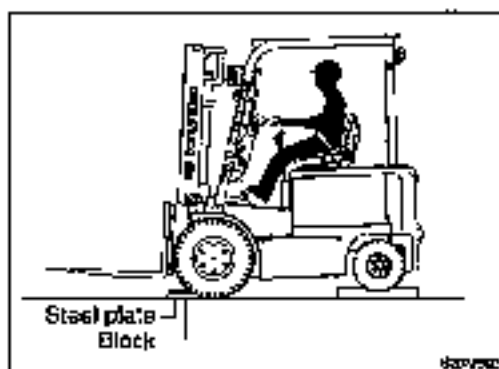

- (5) Tilt mast fully forward. This raises the drive wheels off the floor. Release the tilt control lever and turn engine OFF.

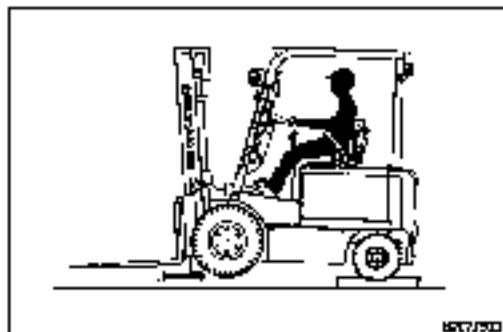

- (6) Insert blocking under the frame behind the drive wheels or slip wheel cradles under the drive wheels. If using blocking, check for safe clearance between drive wheels and floor and blocks.

- * When forks are raised as in illustration above, use shop rags, paper, or bright tape on fork tips to signal the danger of tripping.

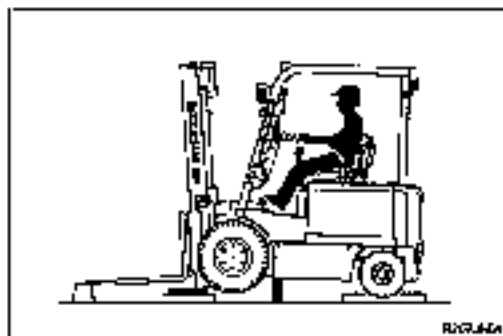

- (7) Check for stable condition of the truck. Be sure that the blocks are located securely under the truck frame before operating the drive or working on truck.
(8) Lower the drive wheels to the floor and remove the blocks by reversing the above procedure.

4) RAISING TRUCK WITH A HOIST

When suitable equipment is available, the front of the truck may be raised by means of a hoist, with wheel cradles placed under the wheels or blocking placed under the frame.

- △ When lifting the front of the truck, watch truck for signs of lateral instability. It may tip sideways. You may have to support or guide the side of the truck or overhead guard to prevent tipping.

- (1) Park truck safely as described in "Safe Parking". Block rear steer wheels.
- (2) Check traction bolts to make sure they are tightened to correct torque. Bolt torques must be 7.5-8.0kg·m(55-59ft·lb).
- (3) To raise the front of the truck using the mast, spread two chains on the outer rail tiebar the mast.

▲ Chain and hoist used to lift truck should be checked to make sure they are of safe lifting capacity. See the truck data plate for information.

- (4) Slowly lift truck and lower drive wheels into the cradles or place blocking under frame prop points.
- (5) When maintenance work is completed, lower the truck to the floor by reversing the lifting procedure. Check to be sure no tools or equipment are under the truck or wheels.

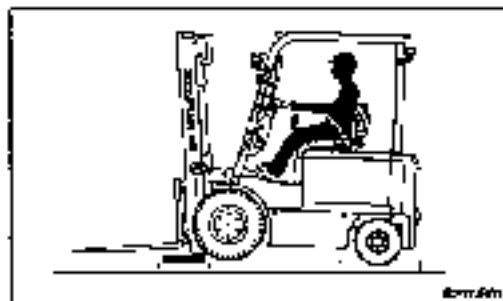

5) BLOCKING THE MAST IN RAISED POSITION

This procedure is used to safely provide clearance for access from the front of truck to components on or near the drive axle. Illustrations show mast with forks removed. However, fork removal is not necessary.

- (1) Park truck safely as described in "Safe Parking".
- (2) Put blocks in front of and behind drive wheels.
- (3) Put wooden support blocks conveniently near mast rails before raising the mast. Use two 1118mm(44in) hardwood blocks or equal, of about 305mm(12in) and 610mm(24in) length.

× **For standard masts, block may need length cut to suit. For triple stage masts the carriage may be blocked up, as shown.**

- (4) Start truck and raise the mast carriage.

- (5) Hold the taller block against inner rail and lower the mast until carriage rests on block.

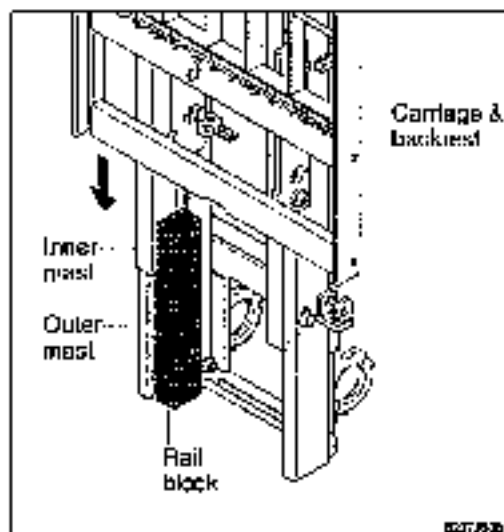

- (6) Hold the shorter block against the outer rail and lower the mast until inner rail rests on the block.

- (7) Reverse the procedure to remove blocking.

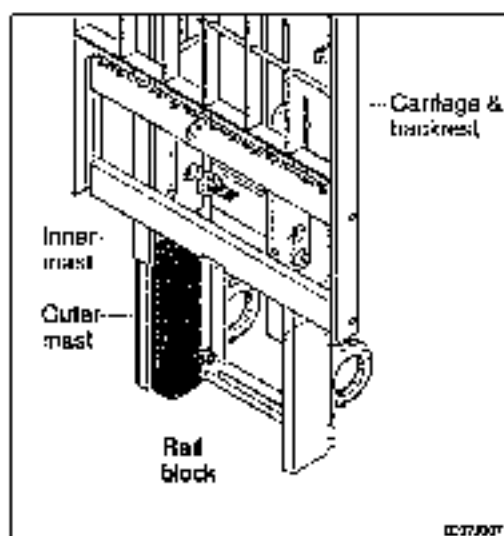

6) RAISING REAR OF TRUCK

The truck may be raised at the rear by jacking and blocking under the center of the frame member at either the front or rear steer axle mounting, or under the center section of the steering axle.

Refer to truck data plate for truck weights.

(1) Park truck safely as described in "Safe Parking". Put blocks at front and rear of drive wheels.

(2) Put a floor jack under the steering axle mounting frame member, centered between the two wheels.

• If there is insufficient clearance under frame for your jack, the truck may first be driven onto shims, to increase the ground clearance.

(3) Raise the truck only as high as necessary to perform the maintenance work.

(4) Put blocks at both sides of the truck, fully under the frame main side structure. Put the blocks in front of but close to the counterweight and rear wheels for the best truck stability.

(5) Put an equal amount of blocks under each side of the truck to provide a level working position.

Lower the truck onto the blocks and remove the jack.

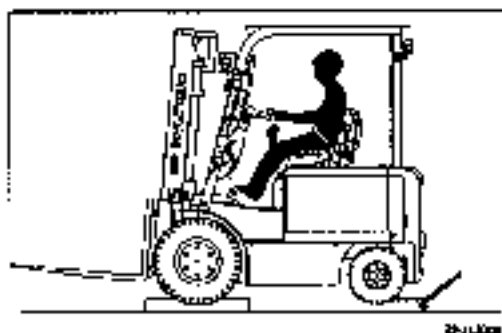

△ Before performing any maintenance work, check the truck for stable condition on the blocking.

(6) When maintenance work is completed, lower the rear side of the truck to the floor by reversing the above procedure and lowering each side of the truck 50mm(2in) at a time:

- Put jack under frame and raise truck.
- Carefully remove blocks and lower truck.
- Remove jack and blocks from drive wheels.

7) RAISING ENTIRE TRUCK

Refer to truck data plate for truck weights.

(1) Park truck safely as described in "Safe Parking". Lower must fully.

(2) If necessary, drive truck onto boards to increase ground clearance.

▲ **LATERAL TIP OVER.** When jacking side of truck, be sure mast is lowered fully and do not raise one side of the truck more than about 60mm(2in) higher than the other, to avoid tipping truck over laterally.

LONGITUDINAL TIP OVER. If the mast and the transaxle are removed while the truck is blocked up, the truck will tip backwards due to the heavy counterweight. Both mast and counterweight must be removed before attempting to raise the truck for transaxle removal. The back of the truck must be supported by blocking under the steer axle to prevent movement.

The reverse is also true. If the counterweight is removed while the truck is up on blocks, the weight of the mast and transaxle will cause the truck to tip on the front blocks and forward.

(3) Put the jack under side frame near the center of the truck.

⚠ Be sure to put the jack squarely and fully under the main side structure of the frame. Do not put the jack under the outer covers which enclose the fuel and hydraulic sump tanks.

(4) Carefully raise the truck one side at a time, only as high as necessary to do the maintenance work and more than a maximum of 150mm(6in) total.

(5) Put blocks under the side frame at each side of the jack. Spread the blocks close to the steer and drive wheels for maximum stability.

(6) If using one jack, lower the truck onto the blocks and move the jack to the opposite side. Repeat the lifting procedure.

(7) Put the same size blocks under each side of the truck so it will be level.

△ Be sure to put the jack squarely and fully under the main side structure of the frame. Do not put the jack under the outer covers which enclose the fuel and hydraulic sump tanks.

(8) When maintenance work is completed, lower the entire truck to the floor by reversing the lifting procedure. Lower the truck one side at a time, while carefully removing the blocks. Check to be sure no tools or equipments are under the truck or wheels.

⚠ Depending on jack height, shims under the tires may be needed for clearance to allow removal of jack.

8) SHIPPING TIE-DOWN INSTRUCTIONS

(1) Front of Truck

① With mast and Carriage Installed

a. Lower the carriage fully.

b. Put a tie down(e.g., chain) between the carriage fork bars.

② Without a mast and Carriage Installed

a. Put a chain across the truck floor plate.

⚠ Protect truck from chain damage by using covered chain or protective material under the chain at contact points.

(2) Rear of Truck

① Attach the tie down to pocket in bottom of counterweight.

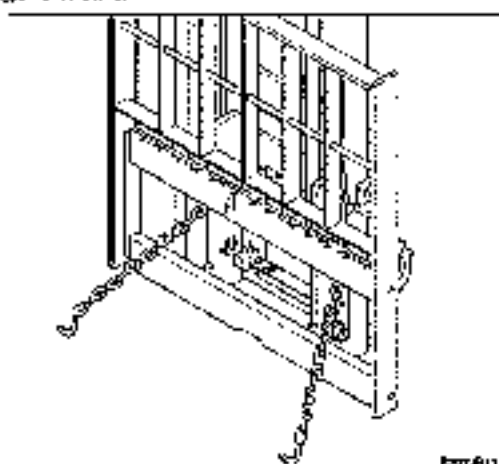
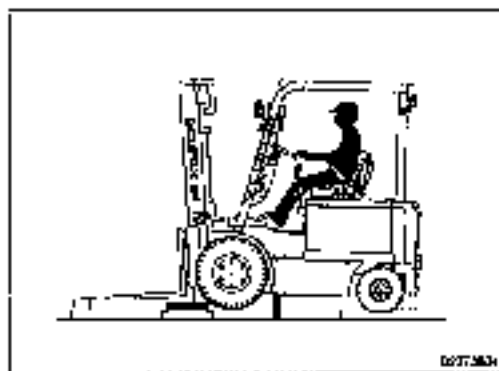

2. OPERATING HAZARDS

1- LOOSE LOADS

⚠ Loose or unbalanced loads are dangerous. Observe these precautions.

Never carry loose or uneven material.



Center wide loads.

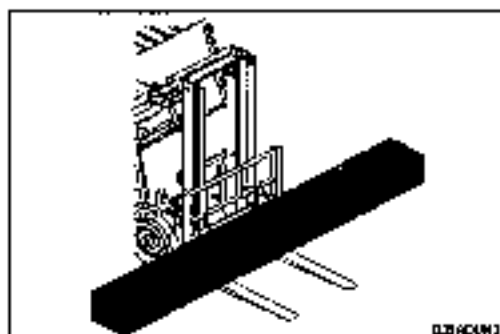

Stack and band loose material.

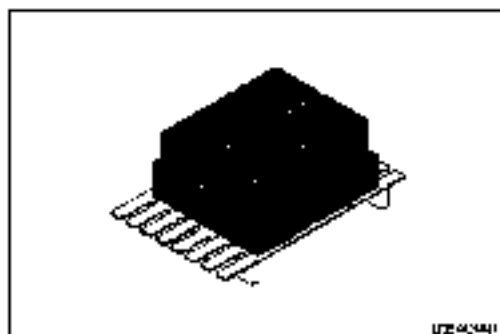

2. LONG AND WIDE LOADS

⚠ With long or wide loads, you need more room. So slow down and watch your clearance.

When extra-long material makes it necessary to travel with the load elevated, do so with extreme care and be alert to load end-swing when turning.

⚠ A long load reduces the capacity of the truck. Know and understand your truck load rating.

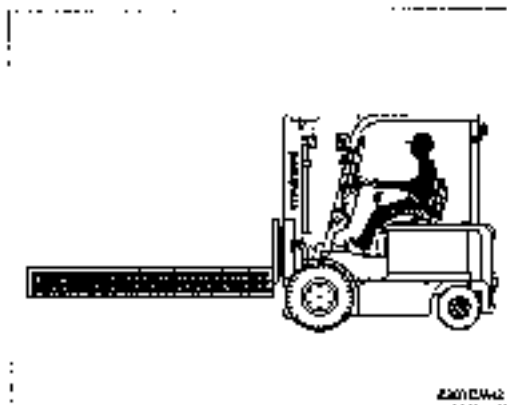

3. REAR SWING

⚠ When turning, be sure the rear end of the truck does not swing into racks, posts, etc. Watch for pedestrians beside the truck.

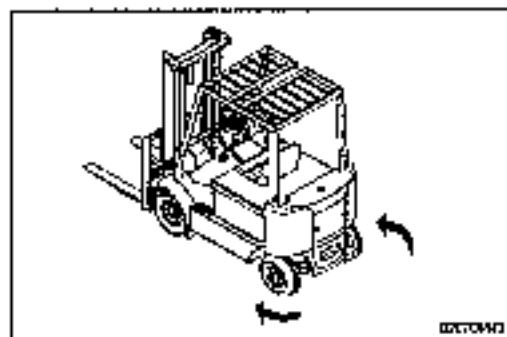

4: LOW OVERHEAD CLEARANCE

- ⚠ Know the height of your truck, with and without a load. Check your clearances. Keep the load low and tilted back.

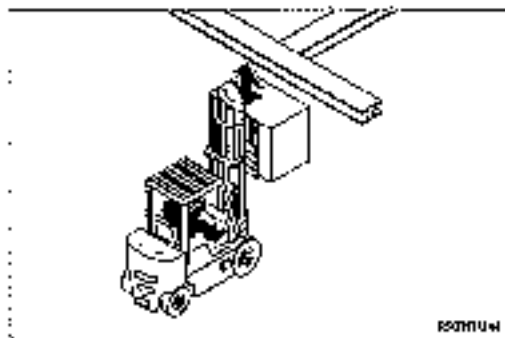

R407004

- ⚠ Watch overhead clearance: Moving into overhead structures can tip a truck over, or spill a load.

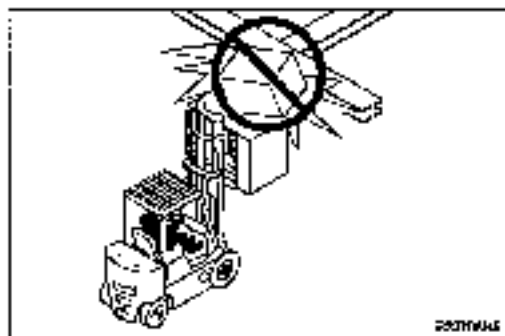

R407005

5: FAST TURNS AND HIGH LOADS

- ⚠ Slow down before turning. The truck can tip over.

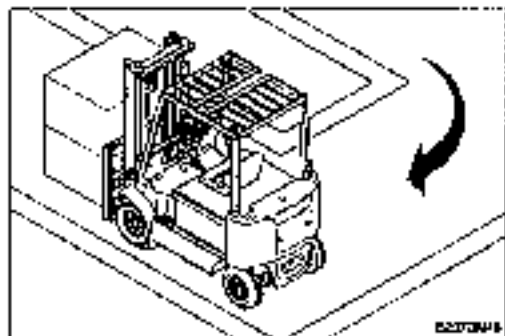

R407006

- ⚠ Turn too sharp with a raised load and your truck can tip even at slow speeds. Travel with a load raised only when removing or depositing a load.

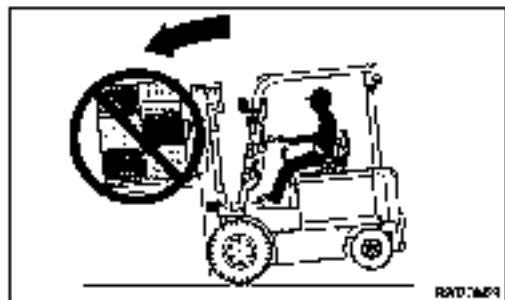

R407007

6. DROP-OFFS

⚠ To avoid these hazards, you must:

- 1) Talk to the truck driver yourself: make sure the driver does not move the trailer until you are done.
- 2) Apply trailer brakes.
- 3) Use wheel chocks.
- 4) Use trailer-to-cock locking system if available.

⚠ The impact of moving in and out of a trailer may cause the trailer to creep or move.

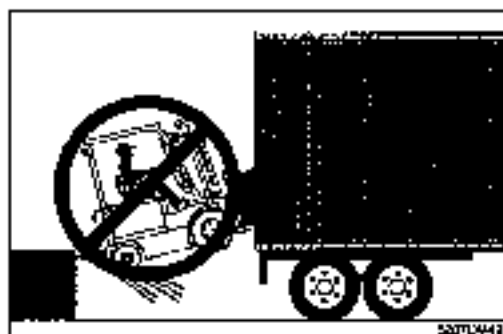

7. RIGHT ANGLE STACKING

⚠ When right angle stacking or moving with a raised load to clear low objects, avoid sharp turns and move slowly.

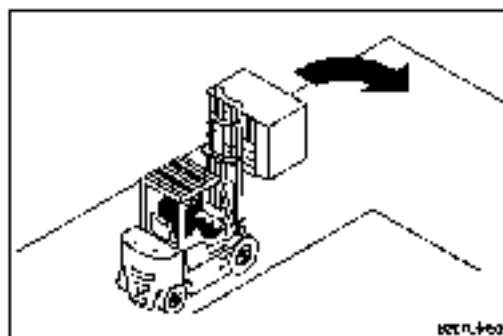

8. CHAIN SLACK

- ▲ Slack chains mean rail or carriage hang-up.
Raise the forks before you move, or broken chains can result.

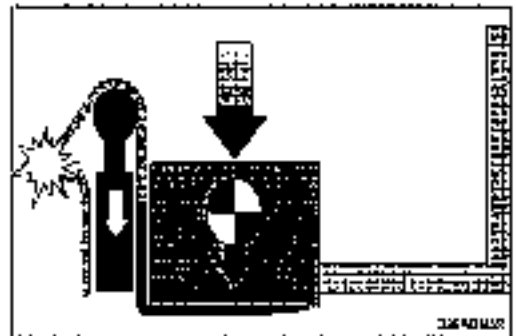
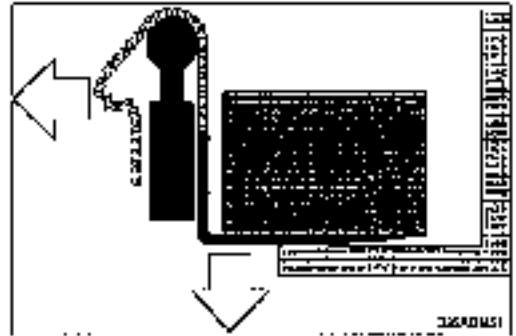

9. PALLETS AND SKIDS

- ▲ Do not move or store materials on damaged pallets or skids. Items can fall through them causing severe injury or death.
- ▲ Be sure the pallet or skid you are using is in good condition and does not have defective or missing components and fasteners.

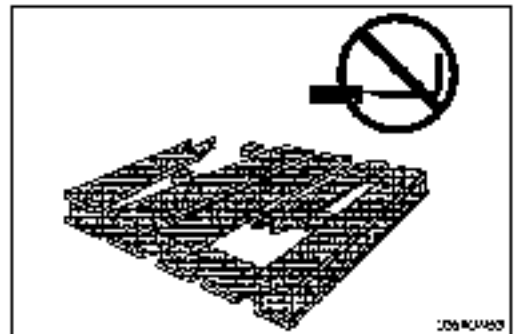

10. CAUTION FOR ELECTRICAL LINES

- ▲ When moving the machine with the mast raised, watch out electrical lines over the machine.
- ▲ The operation near the electrical lines is very dangerous.
Operate within safe working permitted as below.

Supply voltage	Min. safe separation
6.6 kV	3m (10ft)
33.0 kV	4m (13ft)
68.0 kV	5m (16ft)
154.0 kV	8m (26ft)
275.0 kV	10m (33ft)

- ▲ If the machine touches the electric power lines, keep sitting on the operator's seat and make sure the personnel on the ground do not touch the machine until turning off the electric current.
Jump off the machine without contacting the machine when you need to get off.

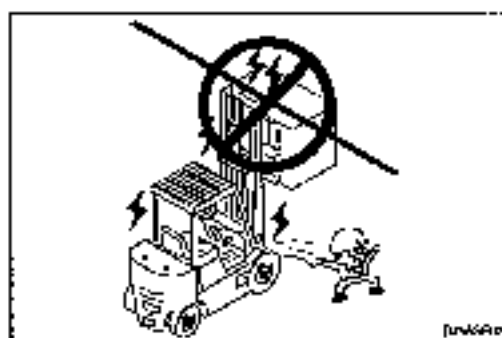
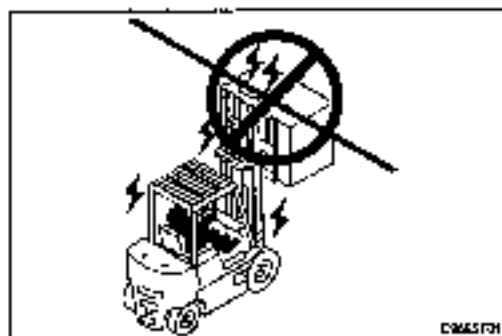

3. KNOW YOUR TRUCK

1: GENERAL LOCATIONS

1) HBF20/25/30/32-7, HBF20/25/30C-7

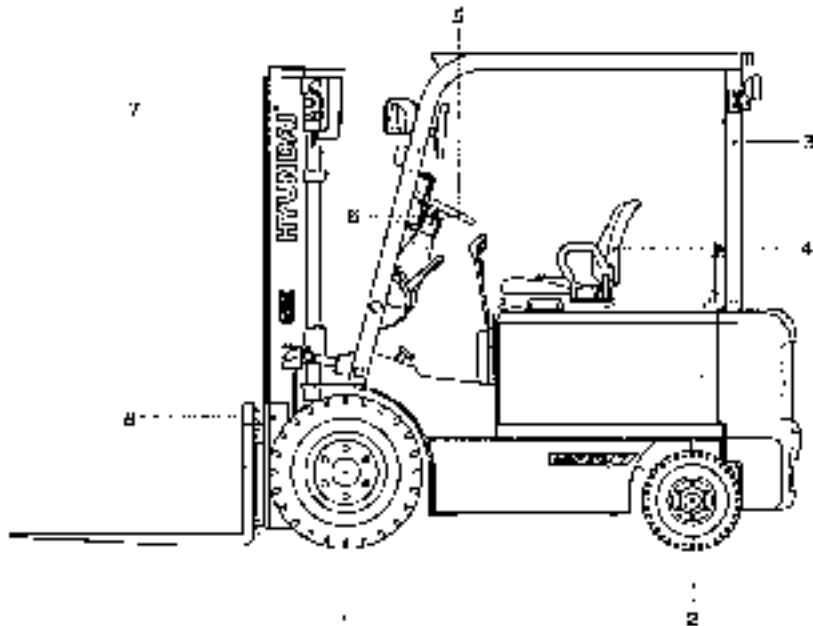

14270424

TRUCK TYPE : Electric Sit-Down Rider, 48 Volt

- | | |
|-----------------------------------|-----------------------------|
| 1 Drive axle, tires and wheels | 5 Steering wheel |
| 2 Steering axle, tires and wheels | 6 Directional control lever |
| 3 Overhead guard | 7 Mast |
| 4 Seat | 8 Carriage and backrest |

2) HBF15/1BT-5

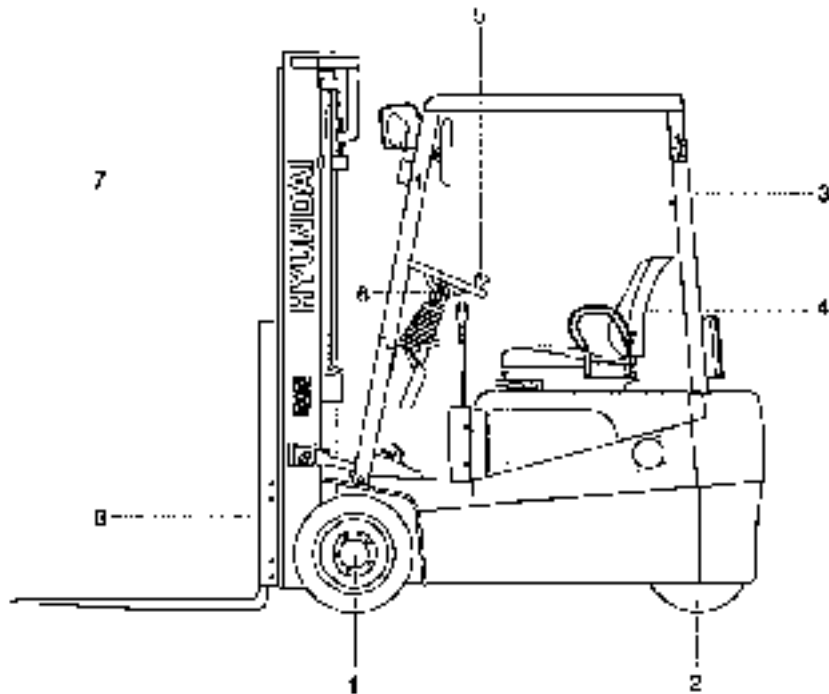

birmeo

TRUCK TYPE : Electric Sit-Down Rider, 3G, 48 Volt.

- | | |
|-----------------------------------|-----------------------------|
| 1 Drive axle, tires and wheels | 5 Steering wheel |
| 2 Steering axle, tires and wheels | 8 Directional control lever |
| 3 Overhead guard | 7 Mast |
| 4 Seat | 9 Carriage and backrest |

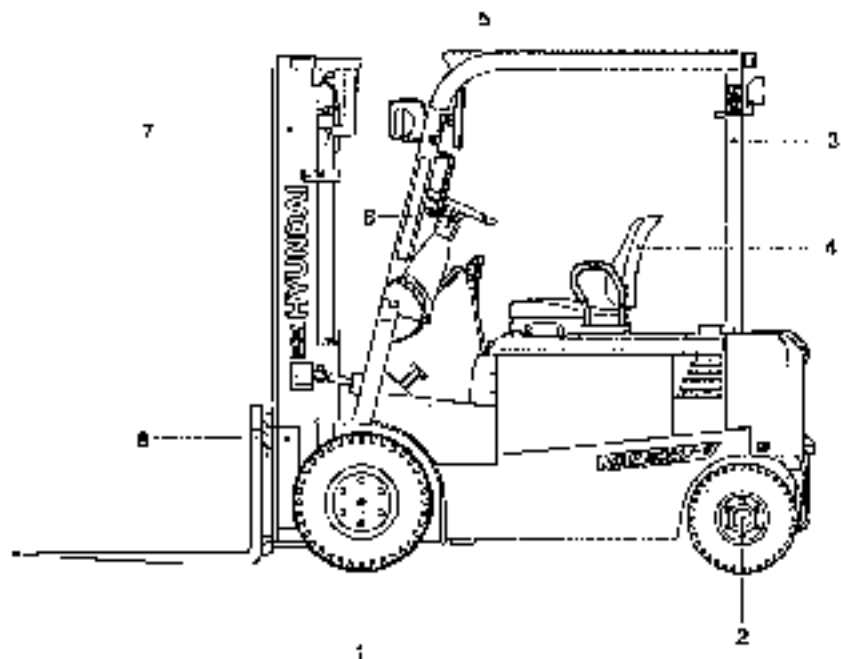

FSM-YM34

TRUCK TYPE : Electric Sit-Down Rider, 20 Volt.

- | | | | |
|---|---------------------------------|---|---------------------------|
| 1 | Drive axle, tires and wheels | 5 | Steering wheel |
| 2 | Steering axle, tires and wheels | 6 | Directional control lever |
| 3 | Overhead guard | 7 | Mast |
| 4 | Seat | 8 | Carriage and backrest |

2. DATA/SAFETY PLATES AND DECALS

1) TRUCK DATA AND CAPACITY PLATE

HYUNDAI CE

Model: _____ Type: _____

Serial No. _____

Attachment _____

Capacity with attachment or load capacity must in vertical position.
Capacities are for centers - inside only.

Load	in	mm	kg
CG	in	mm	kg
h	in	mm	kg
o	in	mm	kg
	In Or		mm

Truck Weight	lb or	kg	Battery	lb or	kg
Max. Capacity	lb or	kg	Life Battery	lb or	kg
Volt	V	Max. Temp. Hrs			

Hyundai Heavy Industries Co. Ltd. Made in Korea S: FH00180

2010046

(1) Truck model number or registered name

(2) Truck serial number

An identification number assigned to this particular truck and should be used when requesting information or ordering service parts for this truck from your authorized HYUNDAI dealer. The serial number is also stamped on the frame.

(3) Attachment description (if any installed)

The user must see that the truck is marked to identify the attachment(s), including the weight of the truck/attachment combination and truck capacity with the attachment.

(4) Capacity rating, load center, and lifting height data

Shows the maximum load capacity of this truck with relation to load centers and fork heights (See diagram on plate). Personal injury and damage to the truck can occur if these capacities are exceeded.

Do not exceed the maximum capacity specified.

(5) Truck weight

The approximate weight of the truck without a load on the forks. This weight plus the weight of the load must be considered when operating on elevators, elevated floors, etc. to be sure they are safe.

(6) Battery weight and system voltage

⚠ Before modifications that affect the stability of safety systems are made written approval from HYUNDAI. This is an OSA requirement. Contact your authorized HYUNDAI dealer for a new nameplate showing the revised capacity.

2) OPERATOR SAFETY WARNING DECAL

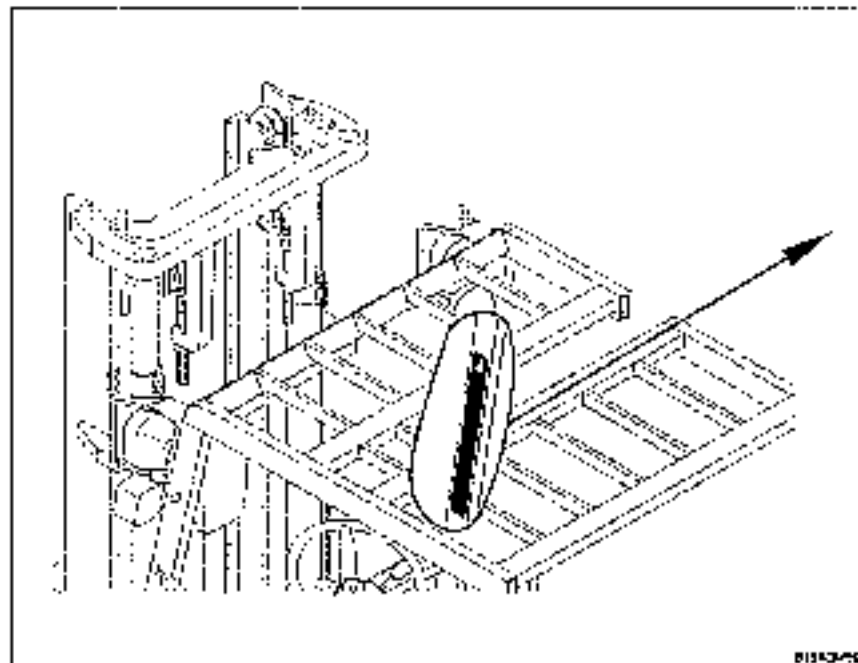

▲ Safety and warning decals are placed in conspicuous locations on the truck to remind you of essential procedures or to prevent you from making an error that could damage the truck or possibly cause personal injury. You should know, understand, and follow these instructions. Safety and warning decals should be replaced immediately if missing or defaced (Damaged or Illegible). Refer to your parts manual for the location of all decals.

▲ Operator/Tip-over warning decal

This decal is located on the front right hand leg of the driver's overhead. Its purpose is to remind the operator that staying in the seat provides the best chance of avoiding injury in the event of a truck-tipping or driving off a dock or ship.

Lift trucks can be tipped over if operated improperly. Experience with lift truck accidents has shown that the driver cannot react quickly enough to jump clear of the truck and overhead guard as the truck tips. To protect operators from severe injury or death in the event of a tip over, it is best to be held securely in the seat. So, please, always buckle up when driving your lift truck.



WARNING

Read the manual



Back Up
Safely



Apply Brake
after losing tires

Watch Out
for Other
people



Fasten Seat
Belt - WE
are to other
people in the
lift truck

Prevent
Overload



AVOID:

- Capacity Exceeded
- Exceeding Capacity
- Exceeding Capacity on Ramp
- Exceeding Capacity on High Loads
- Low Tire Pressure
- Excessive Speed
- Excessive Braking
- Excessive Turning

In Case of
a Tip-Over



Hold on
Tight



Place feet
on floor



Illustration

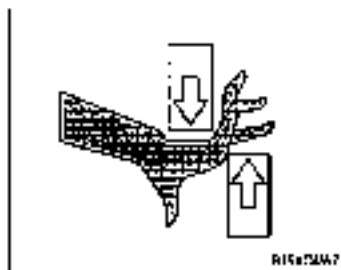

▲ Mast warning decal

This safety decal is placed on the mast to warn of the danger of injury from movement between rails, chains, sheaves, fork carriage, and other parts of the mast assembly. Do not climb on or reach into the mast. Personal injury will result if any part of your body is put between moving parts of the mast.

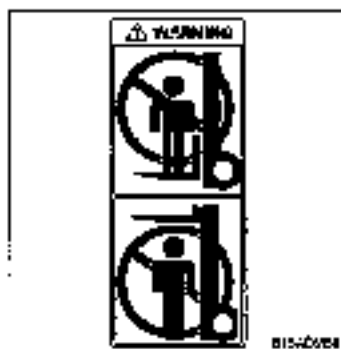

▲ Keep away from forks decal

This safety decal is placed on the mast to warn of the danger of injury from forks when they are in the raised position. Do not ride on or stand under forks or attachments. The forks can fall and cause injury or death. Always make sure that the forks are in the fully lowered position when they are not handling a load.

3. INSTRUMENTS AND CONTROLS

1. HBF20/25/30/32-7, HBF20/25/30C-7, 20BH/25BH/30BH-7

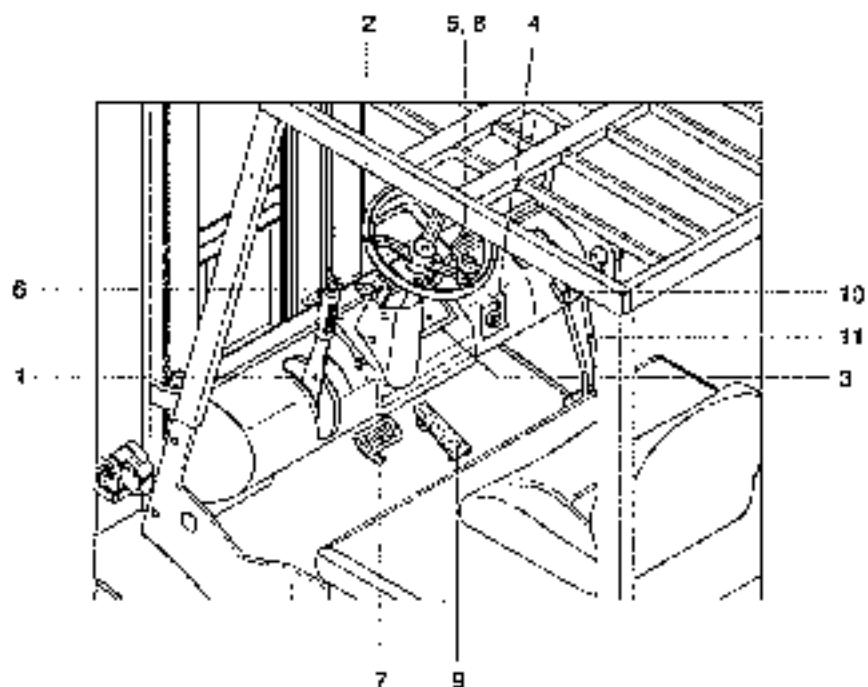

RETTING

- | | | | |
|---|---------------------------|----|--------------------|
| 1 | Parking brake lever | 7 | Brake pedal |
| 2 | Steering wheel | 8 | Flasher switch |
| 3 | Instruments panel | 9 | Accelerating pedal |
| 4 | Key switch | 10 | Lift lever |
| 5 | Head lamp switch | 11 | Tilt lever |
| 6 | Directional control lever | | |

* Familiarize yourself with the controls and follow safe operating procedures.

2. HBF15/18T-S

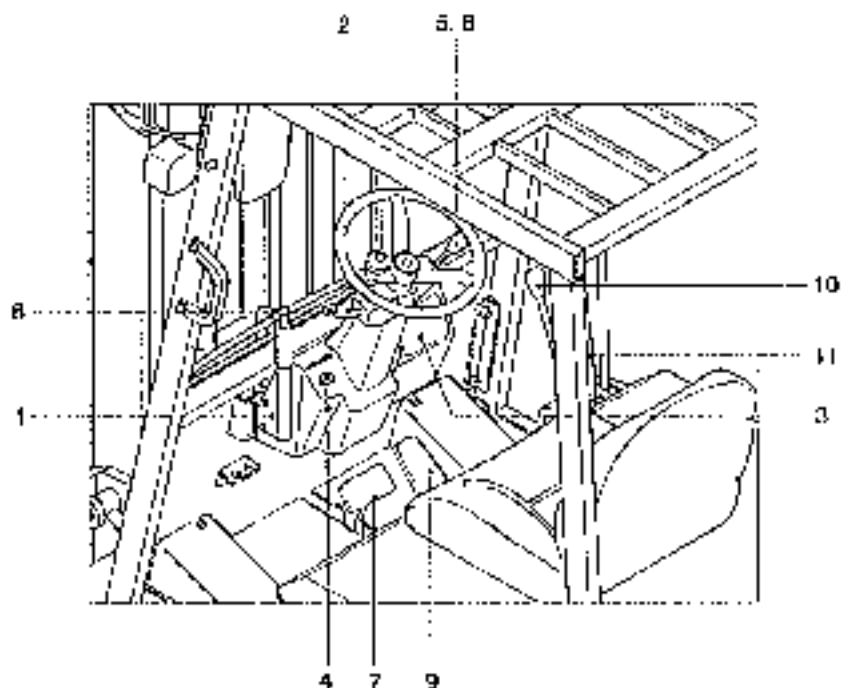

011701-02

- | | | | |
|---|---------------------------|----|--------------------|
| 1 | Parking brake lever | 7 | Brake pedal |
| 2 | Steering wheel | 9 | Flasher switch |
| 3 | Instruments panel | 9 | Accelerating pedal |
| 4 | Key switch | 10 | Lift lever |
| 5 | Head lamp switch | 11 | Tilt lever |
| 6 | Directional control lever | | |

* Familiarize yourself with the controls and follow safe operating procedures.

4 INSTRUMENTS PANEL

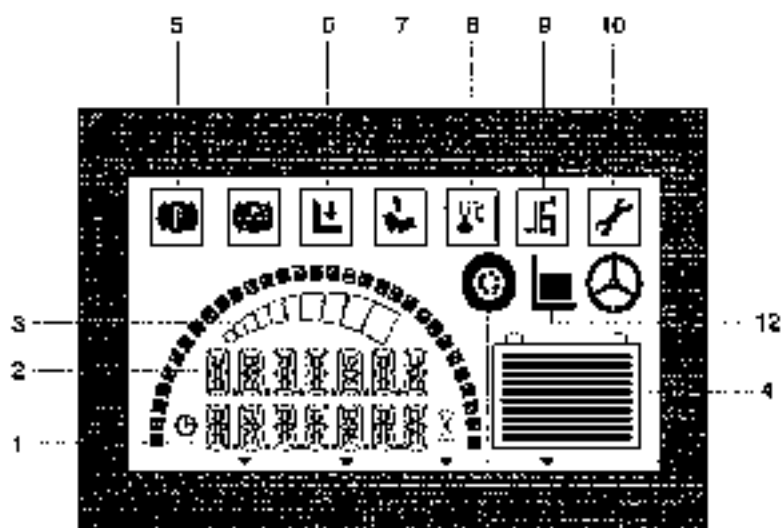

11

85703621

- | | | | |
|---|--------------------------------|----|---------------------------------|
| 1 | Hour meter | 7 | Sequence fault warning lamp |
| 2 | Fault message indicator | 8 | Temperature warning lamp |
| 3 | Accelerator position indicator | 9 | Controller error warning lamp |
| 4 | Battery discharge indicator | 10 | Diagnostic/service warning lamp |
| 5 | Parking brake indicator | 11 | Traction motor warning lamp |
| 6 | Seat open warning lamp | 12 | Pump motor warning lamp |

5. INDICATOR SYMBOLS

1) HOUR METER

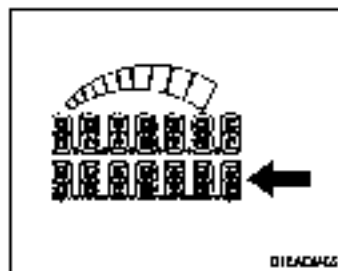

- (1) The hour meter displays traction, pump and key hour used. At power up the hours count display initially indicates key switch hours for approximately 3 seconds, followed by pump pulsing hours for 3 seconds (if applicable), followed by traction pulsing hours which remains permanently displayed, their order can be changed using the calibrator as described on the previous page.

2) FAULT MESSAGE INDICATOR

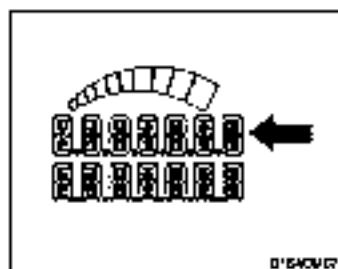

- (1) Fault messages appears when the operation of traction and pump is failed at the cut-out level, pump operation will be inhibited at the end of its present operating cycle.

3) ACCELERATOR POSITION INDICATOR

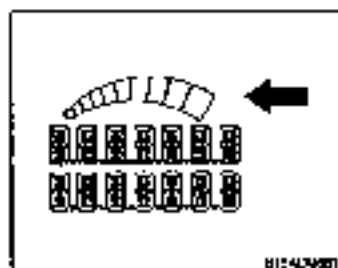

- (1) This symbol indicates accelerator operation.
- (2) Numbers of lamps turned on depend on how far the pedal is depressed

4) BATTERY DISCHARGE INDICATOR



- (1) The state of battery discharge is indicated by 10 segments on the display. When fully charged, all 10 segments will be lit and when fully discharged, all 10 segments will be extinguished, with each 10% drop in capacity extinguishing 1 segment from the top.
- (2) When the battery charge drops below a warning level (30%), warning lit segments will flash to warn the driver of this, when the charge drops further to below an cut-out level (10%) all 10 segments will flash.

6) PARKING BRAKE INDICATOR



(!) This symbol appears if parking brake works.

⚠ If appeared, You can drive neither forward nor reverse. This prevents abnormal operations, such as rapid battery consumption, overheat of driving motor and wear of brake.

6) SEAT OPEN WARNING LAMP



(!) This symbol appears if seat switch opens.

⚠ If appeared, you can drive neither forward nor reverse. This prevents abnormal operation, such as rapid battery consumption, overheat of driving motor and wear of brake.

7) SEQUENCE FAULT WARNING LAMP



(!) This symbol appears if you don't follow the operating sequence of controller.

8) TEMPERATURE WARNING LAMP



(!) This symbol appears if the temperature of controller drive parts (traction or pump) is over 80 °C.

9) CONTROLLER ERROR WARNING LAMP



(1) This symbol appears if the MOSFET goes down.

= MOSFET : Metal Oxide Semiconductor Field Effect Transistor

10) DIAGNOSTIC/SERVICE WARNING LAMP



(1) This symbol appears if any failure in controller is detected or error in diagnostic procedure is detected.

11) TRACTION MOTOR WARNING LAMP

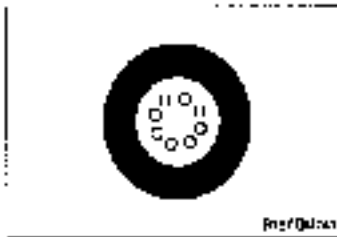

(1) This symbol appears in case of drive motor overheat.

12) PUMP MOTOR WARNING LAMP

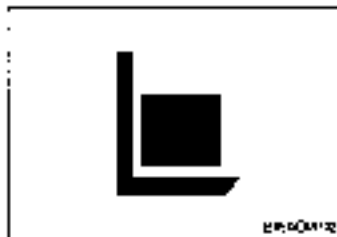

(1) This symbol appears in case of pump motor overheat.

6. OPERATING SWITCHES AND LEVERS

1) KEY SWITCH

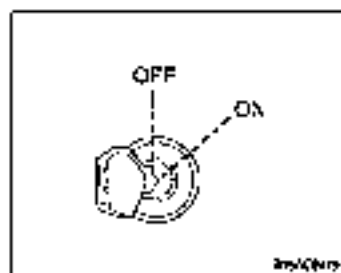

(1) Power is supplied to the control circuit through this switch, which is placed on OFF→ ON clockwise.

- ① OFF : The Key can be removed or inserted and power is turned off.
- ② ON : Both control circuits for hydraulics and running can be activated

2) DIRECTIONAL CONTROL LEVER

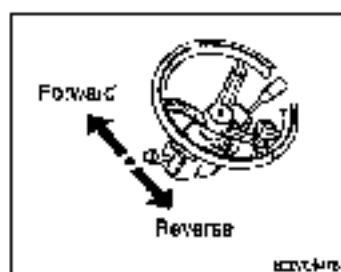

(1) This lever serves to make forward/backward directional changes. For the forward directions, place the lever on the FORWARD position.

(2) In the neutral, the running control circuits is turned off.

(3) For the backward direction, place the lever on the REVERSE position.

(4) The electrical brake will be applied by shifting the lever to the opposite position of running direction.

3) FLASHER SWITCH

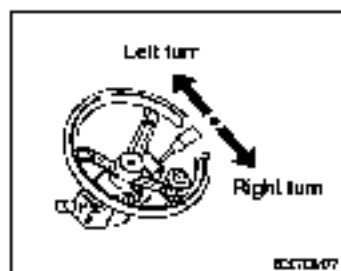

(1) When making a left or right turn, use this switch to flash the flash lamp to indicate which direction the vehicle is turning to.

(2) For a right turn, place the switch on the BACKWARD position.

(3) For a left turn, place the switch on the FORWARD position.

4) HORN SWITCH

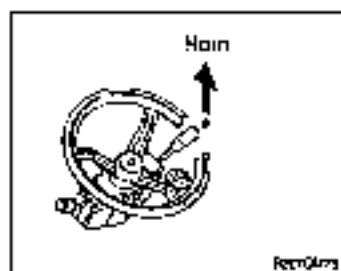

(1) This horn switch is a upward lever type.

(2) The horn lever is reset automatically, if it is released.

5) PARKING BRAKE LEVER



- (1) Position C
Parking brake is applied and front wheel is locked.
 - (2) Position ②
Parking brake is released.
- * Before the truck start, confirm the parking brake is released position.

6) ACCELERATOR PEDAL

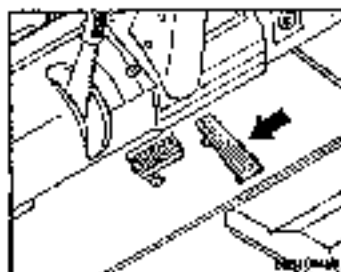

- (1) This pedal is used to vary running speed, which depends upon how far the pedal is depressed.
- (2) In running, the electrical brake will be smoothly applied by shifting the direction lever to the position opposite to the direction of vehicle advanced, and if the pedal is further depressed, the vehicle will run to the opposite direction after stopping once.

7) BRAKE PEDAL

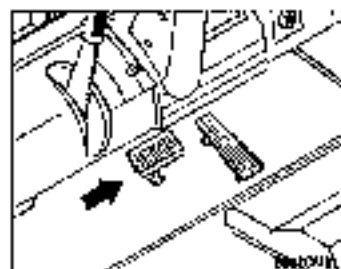

- (1) When this pedal is depressed, the vehicle is braked, while the braking lamps attached on the rear light.
- ▲ Special care should be required for the operation of the brake at loading.

8) STEERING WHEEL

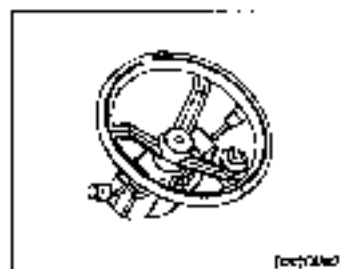

- (1) The steering wheel of the vehicle is provided with the knob to allow steering with one hand.
 - (2) Perform the loading operation with the right hand and operate the steering wheel with the left hand.
 - (3) Adjustable steering column enables selection of the best driving position.
- ▲ Particular care should be taken for the rapid operation of the steering wheel.

9) LIFT LEVER

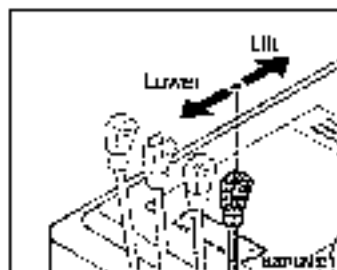

- (1) This lever controls the lifting and lowering of the fork. For lifting, pull the lever backward, and for lowering, push it forward.
- (2) Lifting and lowering speeds can be adjusted by varying the amount of a lever tilt.
- (3) Maximum lowering speed is kept constant regardless of loads through the flow control valve.

10) TILT LEVER

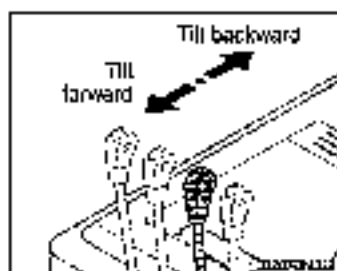

- (1) This lever controls the forward and backward tilt of the mast. For the forward tilt, push the lever forward, and for the backward tilt, pull it backward.
- (2) Tilting speed can be adjusted by varying the amount of lever tilt.

11) SEAT SWITCH



- (1) This switch is closed automatically when an operator sits down on the seat.
- ▲ Before starting the truck seat switch must be closed, otherwise, the truck cannot be started.**

7. SEAT ADJUSTMENT



- 1) The seat adjustment lever is located on the front side under the seat. To unlock, pull the lever up and adjust the seat so that all controls may be comfortably reached. Then release the lever.
- 2) Be sure that the seat locking mechanism is engaged. The seat mounting base provides an 3 inch fore-and-aft adjustment of its slide.

8. BATTERY COMPARTMENT ACCESS

HBF20/25/30/32-7
HBF20/25/30C-7

116F16/18T-5

20BH/25BH 30BH-7



32070466

The combination seat deck/battery compartment cover pivots must to provide access to the battery compartment.

You must tilt the steering column pylon forward before raising the cover.

The cover is held closed by a spring latch located at the front edge. Pull the latch to release the cover. A gas spring helps you pivot the cover upward and hold it in the raised position.

4. DAILY SAFETY INSPECTION

INSPECTING YOUR TRUCK

Before using a lift truck, it is the operator's responsibility to check its condition and be sure it is safe to operate.

Check for damage and maintenance problems; have repairs made before you operate the truck. Unusual noises or problems must be reported immediately to your supervisor or other designated authority.

Do not make repairs yourself unless you are trained in lift truck repair procedures and authorized by your employer. Have a qualified mechanic make repairs using genuine HYUNDAI or HYUNDAI-approved parts.

▲ Do not operate a truck if it is in need of repair. If it is in an unsafe condition, remove the key and report the condition to the proper authority. If the truck becomes unsafe in any way while you are operating it, stop operating the truck, report the problem immediately, and have it corrected.

Lift trucks should be inspected every eight hours, or at the start of each shift. In general, the daily inspection should include the visual and functional checks described on the following pages.

▲ Leaking hydraulic oil may be hot or under pressure. When inspecting a lift truck, wear safety glasses and do not check for leaks with bare hands.

2. VISUAL CHECKS

First, perform a visual inspection of the truck and its major components :

- 1) Walk around your lift truck and take note of obvious damage that may have been caused by operation during the last shift.
- 2) Check that all capacity, safety, and warning plates or decals are attached and legible.
- 3) Check that the battery is installed and secured in position correctly. Check battery connector for safe condition.
- 4) Look for any external leakage around drive axle.
- 5) Check for hydraulic oil leaks and loose fittings.
⚠ Do not use bare hands to check. Oil may be hot or under pressure.
- 6) Be sure that the driver's overhead guard and all other safety devices are in place, securely fastened and undamaged. Inspect for damaged or missing parts, corrosion, cracks, breaks etc.
- 7) Check all of the critical components that handle or carry the load.
- 8) Look the upright and lift chains over. Check for obvious wear and maintenance problems such as damaged or missing parts, leaks, slack or broken chains, rust, corrosion, bent parts, cracks etc.
- 9) Carefully inspect the load forks for cracks, breaks, bending, twists, and wear. Be sure that the forks are correctly installed and locked in their proper position.
- 10) Inspect the wheels and tires for safe mounting, wear condition and air pressure.
- 11) Check the hydraulic sump oil level

3: FUNCTIONAL CHECKS

Check the operation of the truck as follows.

✘ **Before performing these checks, familiarize yourself with the operating procedures in Section 5.**

- 1) Test warning devices, horn, lights, and other safety equipment and accessories.
- 2) With the truck on, check the diagnostic display, or the hour meter and battery discharge indicator (depending on which truck you have). The diagnostic display should show the charge remaining on the battery or a fault code. If the fault code is not an operator fault code call a service technician.
- 3) Be sure all controls and systems operate freely and return to neutral properly. Check the:
 - (1) Service and parking brakes
 - (2) Hydraulic controls : lift, tilt and auxiliary (if installed)
 - (3) Accelerator control
 - (4) Directional control
 - (5) Steering system
 - (6) Tilt mechanism and any attachments

• **When the functional checks are completed:**

- ① Bring truck to complete stop.
- ② Put directional control lever in the NEUTRAL position.
- ③ Apply the parking brake.
- ④ Lower the Tilt mechanism fully.
- ⑤ Turn the starting switch to the OFF position.

• **If you are going to leave the truck unattended:**

- ⑥ Remove the key.
- ⑦ Block the wheels, if the truck is parked on an incline or has the possibility of moving.

4: CONCLUDING THE INSPECTION

Make a record on the "Driver's Daily Checklist" of all the operating and truck problems that you find. Review the checklist to be sure it has been completed and turn it into the person responsible for lift truck maintenance. Be sure any unusual noises or problems are investigated immediately.

Do not operate a lift truck that has a maintenance problem, or is not safe to operate.

Remove the key from the starting switch and put an "OUT OF SERVICE" tag on the truck.

If all of the Daily Inspection checks were normal or satisfactory, the truck can be operated.

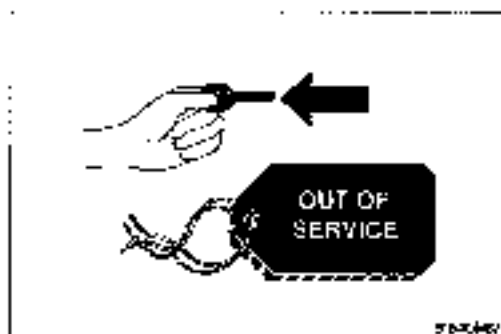

5. OPERATING PROCEDURES

1. BEFORE OPERATING THE TRUCK

Be sure that you have read and understand the information in this Operator's Manual and are trained and authorized before operating the lift truck.

- ⚠ This equipment can be dangerous if not used properly. Safe operation is the responsibility of the operator.
- ⚠ Do not start or operate the truck or any of its functions or attachments, from any place other than the designated operator's position.
- ⚠ Inspect your lift truck before operating at the start of day or shift. Before putting your truck to use, check the operation of the controls and all systems.
- ⚠ Protect yourself. Do not operate truck without a DRIVER'S OVERHEAD GUARD unless conditions prevent its use. Do not remove overhead guard unless specifically authorized. Use special care if operation without this safety device is required.

2. STARTING FROM A SAFE CONDITION

Always start from a safe condition. Before operating a lift truck, make sure that

- 1) The parking brake is applied.
- 2) The forks are fully lowered to the floor or ground.
- 3) You are familiar with how all the controls function.
- 4) All controls are in neutral or other correct position.
- 5) A lift truck has received its daily inspection and is ready to operate.

Put the direction control lever in the NEUTRAL position, before turning the key switch to ON. The truck should start only in the NEUTRAL position.

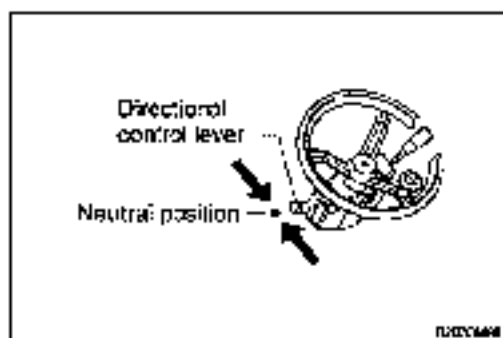
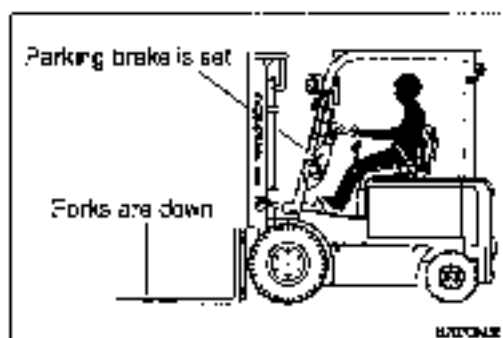

3. ADJUSTING THE SEAT

- 1) Adjust the seat to a comfortable position for you. Adjust the seat by moving and holding the release lever at the front edge of the seat.
 - 2) Put the seat in a position that will provide easy reach to all controls. Release the seat lever. Make sure that the seat locking mechanism is engaged.
- ⚠ Never adjust the driver's seat while the truck is moving, to avoid the possibility of loss of control and of personal injury.**

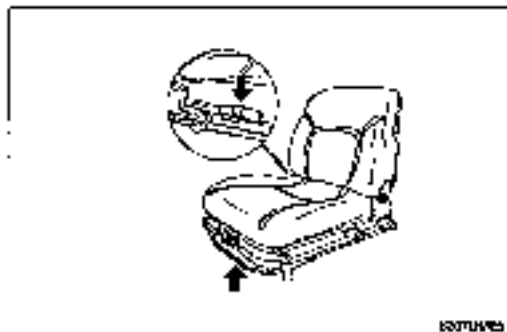

4. STARTING THE TRUCK

Before you start the truck, make sure that you have taken all the above mentioned precautions and that the directional control lever is in NEUTRAL. Also you must sit down on the seat before starting the truck.

To start the truck, turn the key switch clockwise to the ON position.

1) RUNNING

(1) Place the directional control lever on the FORWARD position (or the REVERSE position) and gradually step on the accelerator pedal.

(2) The vehicle will start forward (or backward).

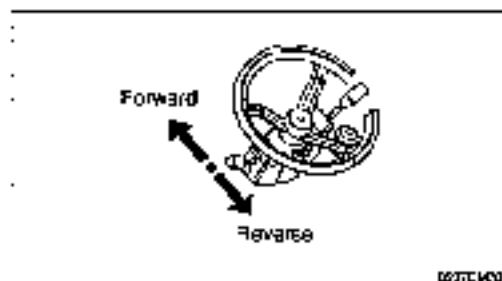

(3) The speed can be controlled from zero to top speed by varying the amount of accelerator pedal depression.

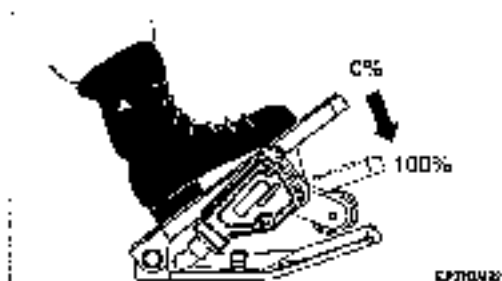

2) TURNING

(1) Hold the steering wheel or knob with the left hand to operate the steering.

(2) Forklift trucks are steered by the rear wheels.

(3) So when travelling FORWARD, keep to the inside and when travelling in REVERSE, keep to the outside when turning.

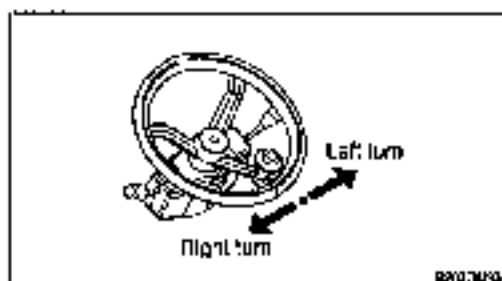

(4) When turning, do not let the outside of the counterweight touch anything.

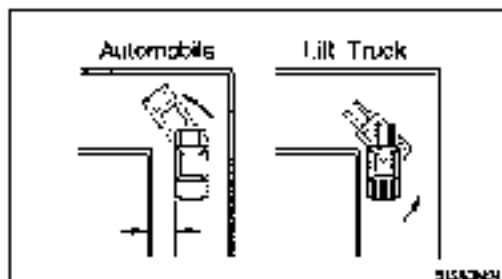

5) STOPPING AND PARKING

(1) Release the foot from the accelerator pedal before and allow the speed to drop before stepping on the brake pedal.

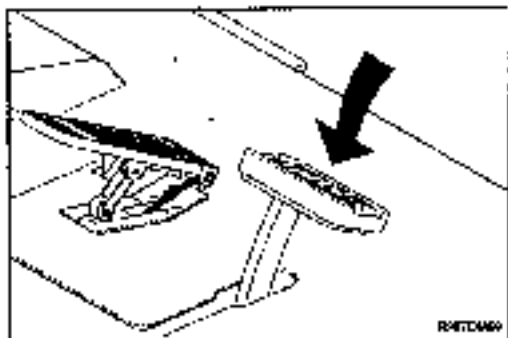

(2) When the vehicle is parked, return the directional control lever to the neutral.

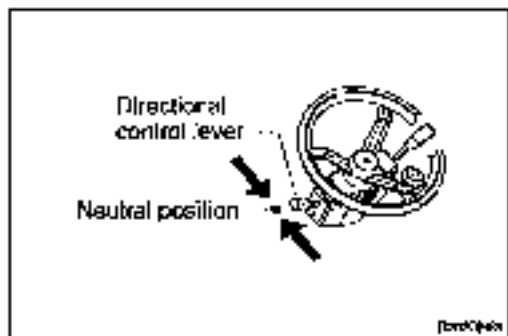

(3) Next, pull up the parking brake lever fully.

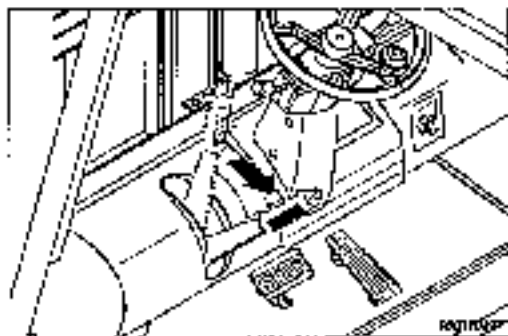

(4) Lower the lock to the lowest position. Tilt the mast forward a little.

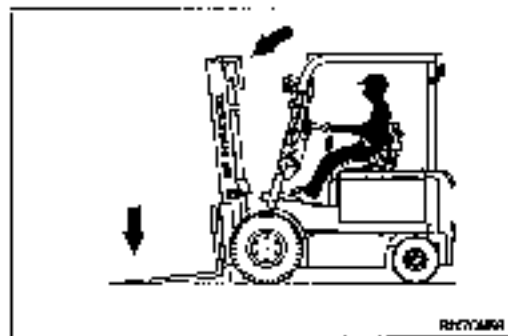

5. CONTROLLING SPEED

With the directional control lever in FORWARD or REVERSE, put your foot on the accelerator pedal and push down smoothly until the truck is moving at the desired speed.

6. BRAKING

To stop the truck, lift your foot from the accelerator pedal and put it on the brake pedal. Push down on the brake pedal in a smooth, firm motion until the truck is stopped.

- ⚠ Stop a lift truck as gradually as practical. Hard braking and wheel sliding are dangerous, increase wear and can cause you to lose a load and damage to the lift truck. Can cause tip-over.**

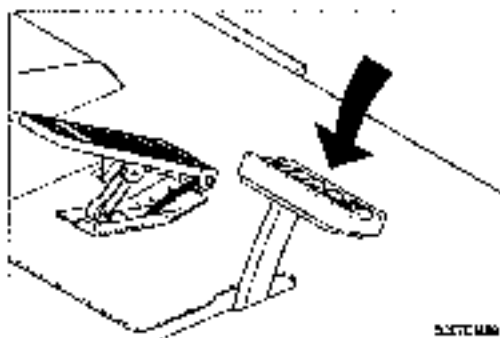

7. PLUGGING

- 1) You can change direction, without braking, by "plugging". As you are traveling, move the directional control lever to the opposite direction and keep the accelerator pedal depressed. The truck should be slow to a smooth, controlled stop and then accelerate in the opposite direction.
 - 2) You can control the plugging distance with the accelerator pedal:
The farther the accelerator is depressed, the shorter the reversal distance.
- ⚠ Be careful when plugging. Any sudden change in direction can cause the load to move or fall off the forks.**

8. OPERATING SAFELY

Safe operation is the responsibility of the operator.

1) Watch where you are going. Don't go if you can't see...

- (1) Before driving, check all around to be sure that your intended path of travel is clear of obstructions and pedestrians.

▲ LOOK WHERE YOU DRIVE. Watch out for pedestrians, other vehicles, obstructions (especially overhead), and drop-offs. If the load blocks your view, drive backwards, except up slopes.

- (2) Do not allow anyone to stand or pass under the load or raised forks.
Watch for people in your work area even if your truck has warning lights or alarms. They may not watch for you.
- (3) Sound horn at intersections and wherever vision is obstructed.
Do not drive a truck up to anyone standing in front of an object.

2) Protect yourself and those around you...

- (1) Operate the truck only from the designated operator's position. Stay within the confines of the lift truck profile dimensions. Keep all body parts inside the operator's compartment and away from the danger of passing obstructions. Keep under overhead guard.

≡ An overhead guard is intended to offer protection to the operator from falling objects, but cannot protect against every possible impact. Therefore, it should not be considered a substitute for good judgement and care in loading, handling, storage, etc.

▲ Keep clear of the mast and lift mechanism. NEVER reach into or put hands, arms, legs, or head into or through the mast structure or near the carriage or lift chains. Never put any part of your body between the mast and the truck.

Don't use the mast as a ladder.

Keep all other persons clear of the load and mast mechanism while attempting to handle a load.

3) No riders...

- (1) Do not carry passengers. The operator is the only one who should be on the truck.

4) Always be in full control of your lift truck...

- (1) Never operate a lift truck or its attachments if you are not in the designated operator's position.
- (2) Never operate a lift truck when your hands and feet are wet or greasy.
- (3) Always pick the smoothest travel route for your lift truck. Avoid bumps, holes, slick, spots, and loose objects or debris in your path that may cause the truck to swerve or tip. If these conditions are unavoidable, slow down and carefully drive past them. Slow down for wet or slippery surfaces.
- (4) Avoid any sudden movement. It can cause the machine to tip-over.
Start, stop, travel, steer, and brake smoothly.
- (5) Operate your lift truck under all conditions at a speed that will permit it to be brought safely to a stop.

- (6) Travel with the fork carriage tilted back and raised only enough to fully clear the ground or obstacles. When the carriage(load) is in an elevated position the stability of the truck is reduced.
- (7) Do not elevate the load except during stacking.

5) Grades, ramps, and inclines...

- (1) Use special care when operating on ramps, inclines, and uneven areas. Travel slowly. Travel straight up and down. Do not turn or drive at an angle across an incline or ramp. Do not attempt to operate on grades in excess of those specified and/or recommended by the manufacturer.
- (2) When the truck is loaded, travel with the load upgrade. When the truck is empty, travel with lifting mechanism(mast) downgrade.
- (3) Always brake with the right foot pedal.(Not with the inching pedal) when travelling down incline.

6) Practice safe operation every time you use your truck..

- (1) Careful driving and operation is your responsibility. Be completely familiar with all the safe driving and load handling techniques in this Operator's Manual. Use common sense. Drive carefully;do not indulge in stunt driving or horseplay. Observe traffic rules. Watch for people and hazards. Slow down, be in full control of your lift truck at all times.
- (2) Follow the instructions in this manual to avoid damage to your truck or the possibility of injury to yourself or others.
- (3) During your work, observe all functions of your lift truck. This allows you to immediately recognize a problem or irregularity that could affect the safe operation of your truck.
- (4) Periodically check the gauges and warning indicator lights in the instrument panel to be sure they indicate a normal condition. If an abnormal condition appears bring the machine to a safe condition and safe location, shut off the starting switch immediately and report the problem.

⚠ Do not continue to operate a truck that has a malfunction. Stop and have it fixed.

⚠ Always wear your seat belt when operating your truck.

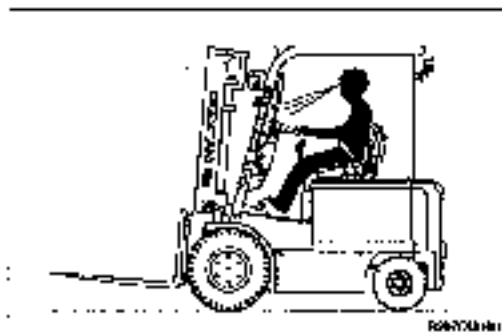

9. LOAD HANDLING

1) GENERAL

Handle only loads that are within the truck rated capacity as shown on the nameplate. This rating specifies the maximum load that should be lifted. However, other factors such as special load handling attachments, load of a high center of gravity, or uneven terrain may dictate that the safe working load be less than the rated capacity. Under these conditions, the operator must reduce the load carried so that the lift truck remains stable.

Handle only stable or safely arranged loads. Do not handle loads made up of loose, unevenly stacked, or unstable items that can easily shift and fall. Take the time to correctly stack and hand loose items. Center the load on the forks.

Do not lift anything that might fall on the operator or a bystander. Do not handle loads that are higher than the fork carriage unless the load is secured so that no part of it can fall backward.

Keep the load back against the LBR. Loads placed out on the ends of the forks can make the lift truck less stable and more likely to tip up.

Lift and lower with the mast vertical or tilted slightly back-never tilted forward.

Operate lift and tilt controls slowly and smoothly. Never tilt the mast forward when the carriage(load) is raised, except to pick up or deposit a load over a rack or stack.

- ▲ Slack chains mean rail or carriage hang-up. Raise the mast before you move. If the mast malfunctions in any way or becomes stuck in a raised position, operate the lift control to eliminate any slack chains by raising the carriage. DO NOT go under a raised mast or forks to attempt repairs.

DO NOT climb the mast or the truck.

Remember your truck is designed to carry loads forward of the front wheels so that the weight of the load is counterbalanced by the weight of the truck.

The further the load is carried from the pivot point(Center of front wheels), the less the weight on the steer wheels. Therefore, always carry the load as close to the front wheels as possible(Bank and flush against the face of the forks.)

The capacity load shown on the nameplate represented by a cube in weight is evenly distributed, with the center of gravity located a standard distance from the face of the forks. If the weight of the actual load to be handled is not evenly distributed, put the heaviest part closest to the carriage.

2) ADJUSTING THE LOAD FORKS

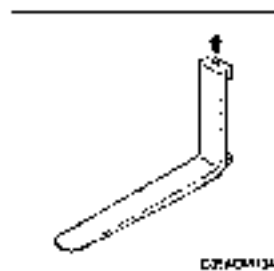

The load forks are adjustable on the hanger, carriage. Forks should be spaced as far apart as the load will allow. Both forks should always be the same distance from the center of the fork carriage. To adjust the forks, raise the carriage slightly. Tilt the mast fully forward to reduce friction and make the fork slide easier. Unlock the fork locking pins.

Position the forks by pushing them away from you. Secure the fork locking pins.

- ▲ Make sure the load backrest(LBR) or fork retaining bolts are fasten securely in place.

3) TRAVELING WITH LOAD

Travel with load or carriage as low as possible and tilted back. Never travel with the load or carriage raised(elevated) in a high position. Do not elevate the load except during stacking.

Observe all traffic regulations and watch for other traffic, pedestrians, and safe clearances. Always look in the direction of travel. Keep a clear view of the path of travel and when the load blocks your visibility, travel in reverse with load trailing.(Except when climbing an incline).

Avoid sudden movements when carrying a load-start, stop, travel, steer, and brake smoothly. Steer clear of bumps, holes, and loose materials or debris on the ground. Lift and tilt slowly and smoothly. Go slowly when turning. Cross railroad tracks slowly and at an angle wherever possible.

Use special care when handling and traveling with long, high, or wide loads-to avoid losing the load, striking bystanders or obstructions, or tipping the truck.

Watch clearances around the truck and load as you travel. Raise the forks or attachment only to pick up or stack a load. Look out for obstructions, especially overhead.

Be aware that exaggerated tail swing, when turning while traveling forward, is a characteristic of lift trucks that are steered by the rear wheels. Accordingly, you need to become accustomed to tail swing and always check the tail swing area of the counterweight to be sure it is clear before you turn.

Always be concerned about the stability of your lift truck. When attachments are used extra care should be taken in securing, manipulating, positioning, and transporting the load. Because attachments generally add extra weight and complexity to the truck, operate trucks equipped with attachments as partially-loaded trucks when not handling load.

4) PICKING UP AND MOVING LOADS

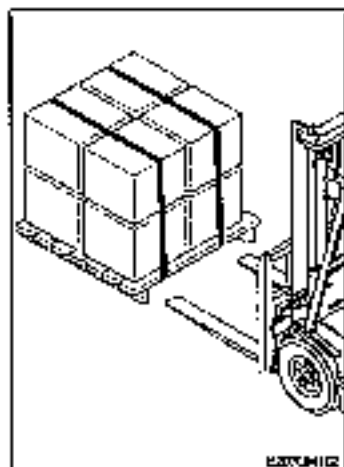

When picking up a load from the ground, approach the load slowly and carefully align the truck square with the load. The forks should be adjusted to fit the load or pallet being handle and spread as wide as possible to provide good stability and balance. Before lifting, be sure the load is centered and the forks are fully under and supporting the load. Fork length should be at least 2/3 of load length. With the lift and tilt controls, adjust the forks to the correct height and angle for freely engaging the load pallet. Move forward until the forks are squarely and completely under the load.

▲ Be Sure that the forks do not extend beyond the load, causing damage or tipping of other adjacent loads or materials behind the load being moved.

If the forks are longer than the load, move the forks partially under the load without extending beyond the load. Raise the load to clear the ground. Back out several inches or whatever distance is necessary. Then set the load down and move forward until the load is positioned against the carriage.

Raise the load from the ground or stack by tilting the mast back just enough to lift the load from the surface. When stacking or tiering, use only enough backward tilt to stabilize the load.

Then raise the load to traveling height and tilt fully back to travel (Except for loads that must be transported as level as possible).

5) UNLOADING

To deposit a load on the floor after being moved into the correct position, tilt the mast forward to a vertical position and lower the load.

Adjust the fork height and tilt the mast forward slightly, as necessary, for smooth removal of the forks from the load (Pallet).

Carefully back away to clear the forks from the load.

Raise the forks to traveling height and lift forks to a level position 150--200mm (6--8in) off the floor.

6) STACKING

(1) To put a load on a stack

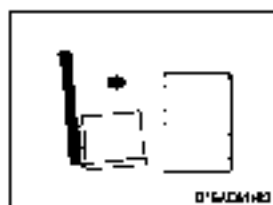

① Approach slowly and align the lift truck and load squarely with the stack.

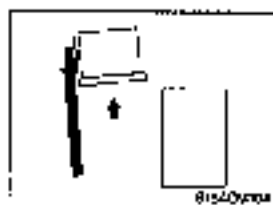

② Raise the load as the lift truck nears the stack.

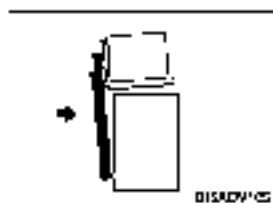

③ Move forward slowly until the load almost touches the stack. The leading edge and sides of the load pallet should line up exactly with the rear edge and side of the load or rack on which you are stacking.

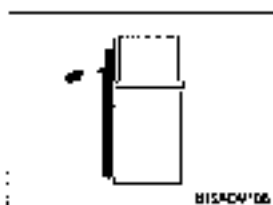

④ Stop close to the stack and further lift the load high enough to clear the top of the stack. Slowly move the load into position. Use care not to damage or move adjacent loads.

⑤ When the load is aligned with the stack beneath it, tilt the mast to the vertical position and carefully lower the load onto the top of the stack.

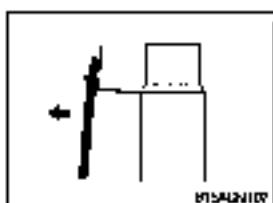

⑥ Lower the forks slightly to clear the load pallet. Tilt the forks forward slightly, if necessary.



⑦ Check your travel path, then carefully back away until the forks are clear of the stack. Stop and lower the forks to the travel position (150-200mm (6-8in) above the ground), then tilt back for travel.

(2) To move a load from a stack

Approach the stack carefully, truck lined up squarely with the load. With mast vertical, raise the forks to the correct height for fully engaging the load/pallet. Adjust fork angle as necessary to fit squarely under the load. Move (inch) forward until the forks are under the load.

Be sure that the forks do not extend beyond the load, causing damage or toppling of other adjacent loads or materials behind the load being moved. If the forks are longer than the load, move the tips partially under the load without extending beyond the load.

Raise the load to clear the under surface. Rack out several inches, then set the load down and move forward until the front face of the forks contacts the load. Be careful that the fork tips now clear the adjacent load or material behind the load being moved.

Raise the load from the stack by tilting the mast back just enough to lift the load from the surface. Or, with the mast still vertical, raise the forks until they begin to lift the load. At this point, apply the minimum back tilt that will stabilize the load.

Check your travel path, slowly back up until clear of the stack, stop, and then lower the load to the travel position (150~200mm(6~8in) off the ground). Tilt full back to travel (Except for certain loads that may have to be transported as level as possible). Be sure the load is back flush against the carriage or front face of the forks.

- **Certain loads must be transported as level as possible.**

10. SHUT DOWN PROCEDURE

* Always leave your lift truck in a safe condition.

1) When you leave your truck, or park it, follow these safety rules:

- (1) Park in a safe area away from normal traffic.
- (2) Never park on a grade.
- (3) Never park in areas that block emergency routes or equipment, access to fire aisles, or stairways and fire equipment.

2) Before leaving the operator's position:

- (1) Bring the truck to a complete stop.
- (2) Put the directional control lever in the NEUTRAL position.
- (3) Apply the parking brake.
- (4) Lower the lifting mechanism-carriage and forks or attachment fully to the ground.

3) In addition, when leaving the truck unattended:

- (1) Tilt the mast forward until the forks are level and flat on the ground.
- (2) Turn the starting switch to the OFF position and remove the key.
- (3) Block the wheels, if the truck must be left on an incline or you have any doubt about the truck moving from a safe position.



5207-2110

6. EMERGENCY TOWING

TOWING PRECAUTIONS

If your lift truck becomes disabled but it can be moved freely on its own wheels without further damage, use the following procedures to tow it safely to a repair area.

- ✖ It is important for your safety and the care of your lift truck to use the proper equipment and carefully follow these recommendations for safe towing.
- ⚠ Do not tow a lift truck if there is a problem with the brakes or tires or the steering cannot be operated. Do not tow up or down ramps and steep inclines. Do not attempt to tow a lift truck if traction or weather conditions are poor.

2. TOWING PROCEDURES

- 1) Be sure to apply the parking brake or block the drive wheels on the disabled truck while working around it.
- 2) When possible, raise the carriage (forks) on the disabled truck about 12 inches (300mm) from the floor or ground. Secure the carriage with a chain.
- 3) Obtain another lift truck of equal or larger size carrying a partial load for traction.
- 4) Check that the counterweight bolts are in place and properly torqued. (This bolt is made of a special high tensile steel and is not commercially available. Replace it, when necessary, only with a genuine HYUNDAI replacement part).
- 5) Use an approved, solid metal tow bar with towing couplers that connect to the towing pins in the counterweights.
- 6) Release the parking brake on the towed vehicle.
- 7) Directional control lever is in the neutral.

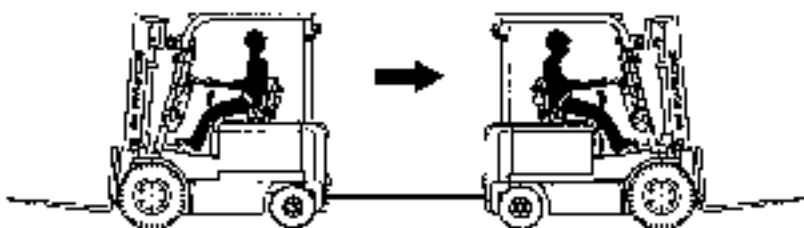

00204111

- 8) Tow the disabled truck backward. An operator must be on the towed truck.

Tow the truck slowly. Careful towing is necessary to prevent injury to personnel or damage to the truck. The truck should be towed at a speed of less than 5mph (8km/h) with a driver in the seat. Do not lift the truck or any wheels off the floor or ground while the truck is being towed.

- ▲ The power steering will not operate on the disabled truck when the hydraulic motor is not running, which makes the steering handwheel difficult to turn.**
- 9) Park the disabled truck in authorized areas only. Fully lower the forks to the floor, put the directional control lever in the NEUTRAL position and turn the starting switch to the OFF position. Engage the parking brake. Remove the key and, when necessary, block the wheels to prevent the truck from rolling.
- ▲ Always engage the parking brake when parking a lift truck. The truck can move and cause injury or death to personnel near it.**

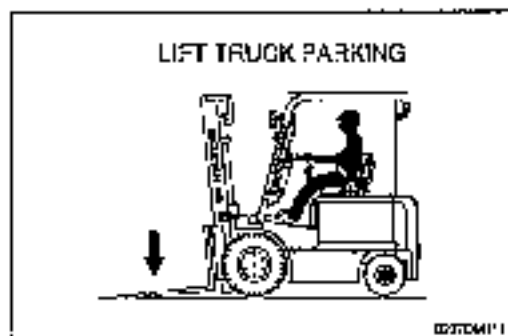

00204111

7. PLANNED MAINTENANCE

1. INTRODUCTION

- **ONLY TRAINED AND AUTHORIZED PERSONNEL** should perform **Planned Maintenance**. Local **HYUNDAI** dealers are prepared to help customers put in place a **Planned Maintenance** program for checking and maintaining their lift trucks according to applicable safety regulations.

2. LIFT TRUCK MAINTENANCE

Regular maintenance and care of your lift truck is not only important for full and efficient truck life also essential for your safety. The importance of maintaining your lift truck in a safe operating condition by servicing it regularly and, when necessary, repairing it promptly cannot be emphasized too strongly. Experience has shown that powered industrial trucks can cause injury if improperly used or maintained. In the interest of promoting safety, several current industry and government safety standards specify that any powered industrial truck not in safe operating condition be removed from service and that all repairs be made by trained and authorized persons.

To assist you in keeping your lift truck in service and in good operating condition, this section outlines maintenance procedures that should be done at regular intervals. This planned approach is considered essential to the life and safe performance of your truck.

It is your responsibility to be alert for any indication that your truck may need service and have it attended to promptly. You play an important part in maintenance. Only you can make sure that your lift truck regularly receives the care it needs.

- ▲ **Powered industrial truck may become hazardous if maintenance is neglected.**

3. PLANNED MAINTENANCE

As outlined in Section 4, **Daily safety inspection**, the operator should make a safety inspection of the lift truck before operating it. The purpose of this daily examination is to check for any obvious damage and maintenance problems and to have minor adjustments and repairs made to correct any unsafe condition.

In addition to the operator's daily inspection, **HYUNDAI** recommends that the owner set up and follow a periodic planned maintenance (PM) and inspection program. Performed on a regular basis by trained personnel, the program provides thorough inspections and checks of the safe operating condition of the lift truck. The PM identifies needed adjustments, repairs or replacements so they can be made before failure occurs. The specific schedule (frequency) for the PM inspections depends on the particular application and lift truck usage.

This Section recommends typical Planned Maintenance and Lubrication schedules for items essential to the safety, life, and performance of the truck. It also outlines safe maintenance practices and gives brief procedures for inspections, operational checks, cleaning, lubrication, and minor adjustments.

Specifications for selected components, fuel, lubricants, critical bolt torques, refill capacities, and settings for the truck are found in Section 8.

If you have need for more information on the care and repair of your truck, see your **HYUNDAI** dealer.

4 PLANNED MAINTENANCE INTERVALS

Time intervals between maintenance are largely determined by operating conditions. For example, operation in sandy, dusty locations requires shorter maintenance intervals than operation in clean warehouses. The indicated intervals are intended for normal operation. The operating condition classifications are:

1) Normal Operation

Eight-hour material handling, mostly in buildings or in clean, open air on clean paved surfaces.

2) Severe Operation

Prolonged operating hours or constant usage.

3) Extreme Operation

(1) In sandy or dusty locations, such as cement plants, lumber mills and coal dust or stone crushing sites.

(2) High-temperature locations, such as steel mills and foundries.

(3) Sudden temperature changes, such as constant trips from buildings into the open air or in refrigeration plants.

If the lift truck is used in severe or extreme operating conditions, you must shorten the maintenance intervals accordingly.

x Since the operating environment of lift trucks varies widely, the above descriptions are highly generalized and should be applied as actual conditions dictate.

The maintenance time intervals referred to in this manual relate to truck operating hours as recorded on the hourmeter, and are based on experience which HYUNDAI has found to be convenient and suitable under typical (normal or average) operating conditions.

5: MAJOR COMPONENT LOCATIONS

1) HBF20/25/30/32-7, HBF20/25/30C-7

Use the illustration below to locate components included in the PM procedures.

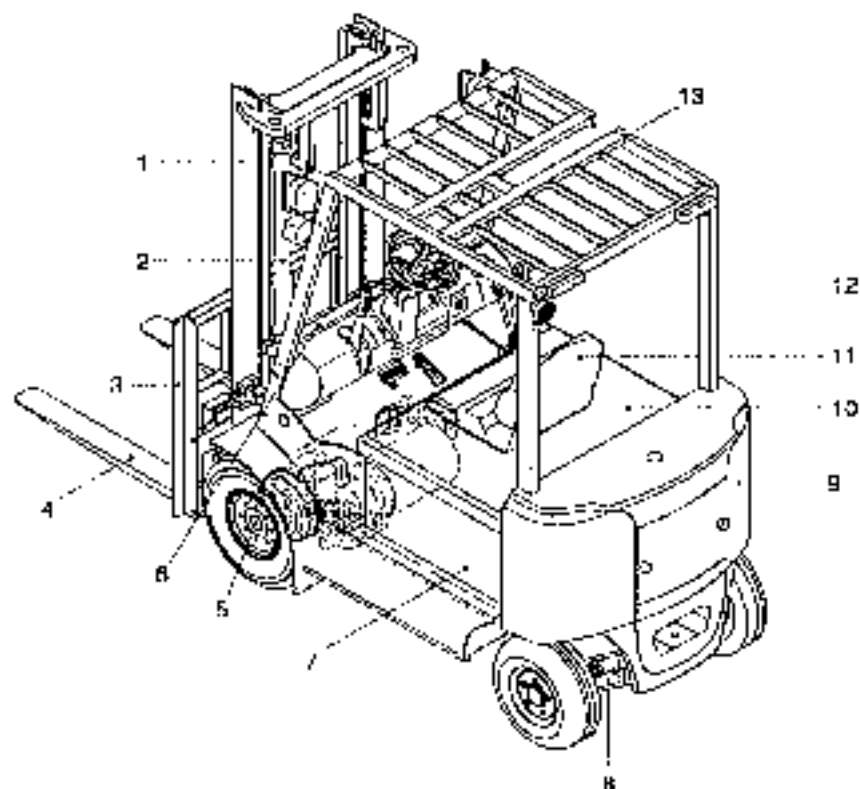

1 Mast	6 Cowl	11 Seat
2 Lift cylinder	7 Frame	12 Steering wheel
3 Carriage and backrest	8 Steering axle	13 Overhead guard
4 Forks	9 Counterweight	
5 Drive unit	10 Battery	

8220V113

2) H6F16/16T-5

Use the illustration below to locate components included in the FM procedures.

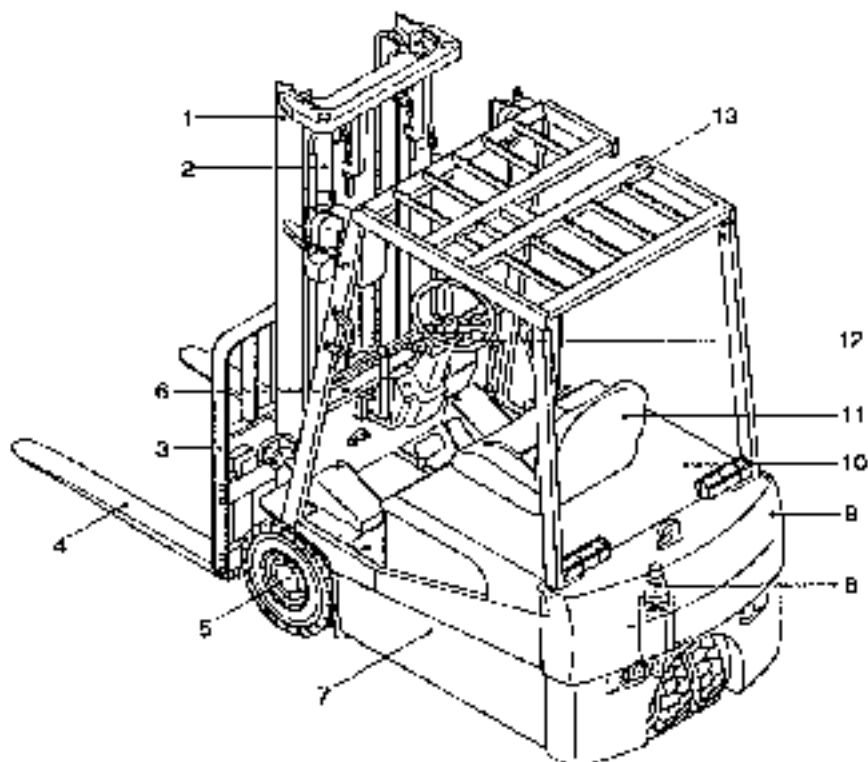

01-0790M1-03

- | | | |
|-------------------------|-----------------|-------------------|
| 1 Mast | 6 Cowl | 11 Seat |
| 2 Lift cylinder | 7 Frame | 12 Steering wheel |
| 3 Carriage and backrest | 8 Steering axle | 13 Overhead guard |
| 4 Forks | 9 Counterweight | |
| 5 Drive unit | 10 Battery | |

3) 20BH/25BH/30BH-7

Use the illustration below to locate components included in the FM procedure.

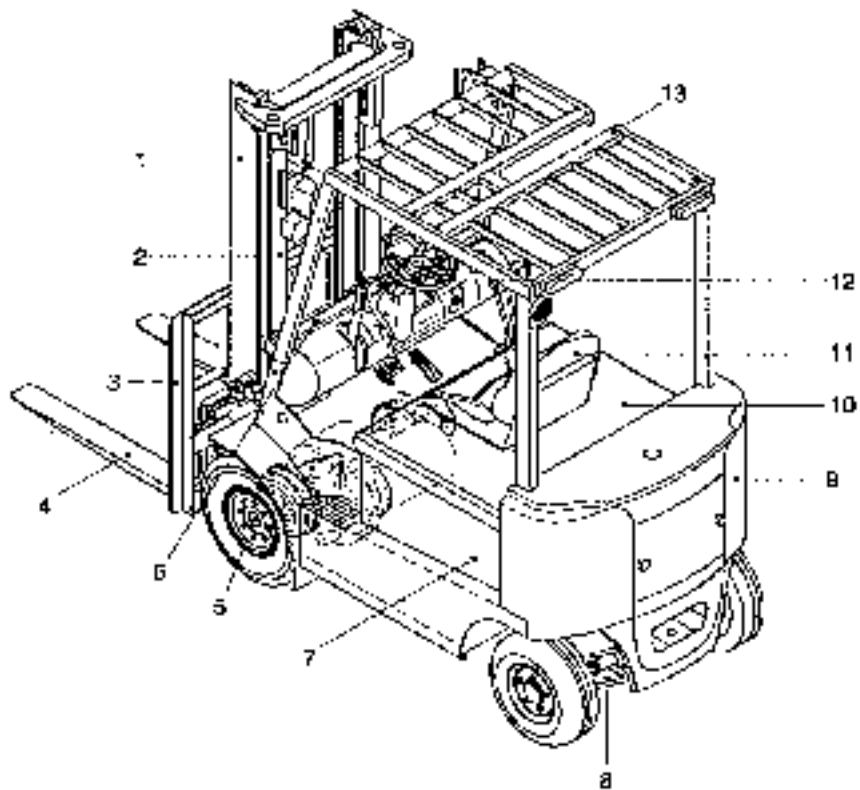

120173W:13

- | | | |
|-------------------------|-----------------|-------------------|
| 1 Mast | 6 Cowl | 11 Seat |
| 2 Lift cylinder | 7 Frame | 12 Steering wheel |
| 3 Carriage and backrest | 8 Steering axle | 13 Overhead guard |
| 4 Forks | 9 Counterweight | |
| 5 Drive unit | 10 Battery | |

6. DAILY MAINTENANCE CHECKS

The PM intervals are depend on hour meter records of operation.

PM Interval

A : 8-10 hours or daily

B : 50-250 hours or every month (Typical PM interval)

C : 450-500 hours or every 3 months

D : 900-1000 hours or every 6 months

F : 2000 hours or every year

Daily maintenance checks	A	B	C	D	F
Check truck for obvious damages and leaks.	●				
Check clean battery terminals.	●				
Check electrolyte level.	●				
Check capacity, working plates and decals.	●				
Check condition of tires and wheels. Remove embedded objects. Check air pressure	●				
Check for missing or loose wheel lug nuts.	●				
Check hydraulic pump oil level.	●				
Check gauges and instruments.	●				
Check warning lights and hourmeter.	●				
Check overhead guard condition and bolts.	●				
Check horn operation and other warning devices.	●				
Check steering operation.	●				
Check service brake operation.	●				
Check parking brake operation.	●				
Check directional and speed controls operation.	●				
Check accelerator.	●				
Check lift, lift and auxiliary operation.	●				
Check mast, lift chains and fasteners.	●				
Check carriage or attachments and forks.	●				
Check seat, deck holddown latch for correct locking.	●				
Check optional safety equipment (Alarms, Lights etc.)	●				

7 PERIODIC MAINTENANCE CHECKS

The PM intervals are depend on hour meter records of operation.

PM interval

A : 8-10 hours or daily

B : 50-250 hours or every month(Typical PM interval)

C : 450-600 hours or every 3 months

D : 900-1000 hours or every 6 months

E : 2000 hours or every year

Periodic checks and planned maintenances (PM)	A	B	C	D	E
Check truck visually and inspect components.		●			
Test drive truck/check functional performance.		●			
Check torque on critical fasteners.		●			
Lubricate truck.(See component)		●			
Clean/Check battery terminals, electrolyte level.		■			
Check battery cables/truck receptacle		●			
Perform battery load test.		●			
Check drive motor brushes.		●			
Check hydraulic motor brushes.		■			
Test ground.		■			
Clean drive axle air vent.		●			
Check drive axle fluid level.		■			
Drain and replace drive axle fluid.					■
Check drive axle mounting and bearings.		●			
Check brake condition and wear.		■			
Lubricate steering axle linkage.		■			
Check/lubricate steering axle wheel bearings.					■
Replace hydraulic pump fluid and filter.					■
Clean/replace hydraulic pump breather.				■	
Lubricate tilt cylinder rod ends.		■			
Lubricate mast fittings.		■			
Check lift chain adjustment and wear.		■			
Check/lubricate lift chains.		●			
Lubricate mast rollers.		■			
Check contactors (Replace contactor tips if roughness is remarkable)		●			

8. SAFE MAINTENANCE PRACTICES

The following instructions have been prepared from current industry and government safety standards applicable to industrial truck operation and maintenance. These recommended procedures specify conditions, methods, and accepted practices that aid in the safe maintenance of industrial trucks. They are listed here for the reference and safety of all workers during maintenance operations. Carefully read and understand these instructions and the specific maintenance procedures before attempting to do any repair work. When in doubt of any maintenance procedure, please contact your local HYUNDAI dealer.

- 1) Powered industrial trucks can become hazardous if maintenance is neglected. Therefore, suitable maintenance facilities, trained personnel and procedures shall be provided.
- 2) Maintenance and inspection of all powered industrial trucks shall be performed in conformance with the manufacturer's recommendations.
- 3) Follow a schedule/planned maintenance, lubrication and inspection system.
- 4) Only trained and authorized personnel are permitted to maintain, repair, adjust and inspect industrial trucks and must do so in accordance with the manufacturer's specifications.
- 5) Always wear safety glasses. Wear a safety(hard) hat in industrial plants and in special work areas where protection is necessary and required.
- 6) Properly ventilate work area and keep shop clean and floors dry.
- 7) Avoid fire hazards and have fire protection equipment present in the work area. Do not use an open flame to check for fluid or electrolyte levels.
- 8) Before starting work on truck
 - (1) Raise drive wheels free of floor and use chock blocks or other positive truck positioning devices.
 - (2) Remove all jewelry (watches, rings, bracelets, etc.).
 - (3) Put blocks under the load-engaging means, inner mats or chassis before working on them.
 - (4) Disconnect the battery connector before working on the electrical system.
x Refer to the 1-15 "Jacking and Blocking" section for proper procedures.
- 9) Operation of the truck to check performance must be conducted in an authorized, safe, clear area.
- 10) Before starting to operate the truck:
 - (1) Be seated in a safe operating position.
 - (2) Make sure parking brake is applied.
 - (3) Put the directional control lever in NEUTRAL.
 - (4) Check functioning of lift and tilt systems, direction and speed controls, steering, brakes, warning devices and load handling attachments.

- * 1) Before leaving the truck
 - (1) Stop the truck.
 - (2) Fully lower the load-engaging means: mast, carriage, forks or attachments. Tilt mast forward.
 - (3) Put the directional control lever in NEUTRAL.
 - (4) Apply the parking brake.
 - (5) Turn the key switch to the OFF position.
 - (6) Put blocks at the wheels if the truck must be left on an incline.
- * 2) Brakes, steering mechanisms, control mechanisms, warning devices, lights, lift overload devices, lift and tilt mechanisms, articulating axle stops, load restraint, overhead guard and frame members must be carefully and regularly inspected and maintained in a safe operating condition.
- * 3) Special trucks or devices designed and approved for hazardous area operation must receive special attention to insure that maintenance preserves the original approved safe operating features.
- * 4) All hydraulic systems must be regularly inspected and maintained in conformance with good practice. Tilt and lift cylinders, valves and other parts must be checked to assure that drift or leakage has not developed to the extent that it would create a hazard.
- * 5) When working on the hydraulic system, be sure the battery is disconnected, mast is in the fully-lowered position and hydraulic pressure is relieved in hoses and tubing
 - ▲ Always put blocks under the carriage and mast rails when it is necessary to work with the mast in an elevated position.**
- * 6) The truck manufacturer's capacity, operation, and maintenance instruction plates, tags, or decals must be maintained in legible condition.
- * 7) Batteries, limit switches, protective devices, electrical conductors and connections must be maintained in conformance with good practice. Special attention must be paid to the condition of electrical insulation.
- * 8) To avoid injury to personnel or damage to the equipment, consult the manufacturer's procedures in replacing contacts on any battery connection.
- * 9) Industrial trucks must be kept in a clean condition to minimize fire hazards and help in detection of loose or defective parts.
- * 20) Modifications and additions that affect capacity and safe truck operation must not be done without the manufacturer's prior written approval. This is an OSHA requirement. Capacity, operation and maintenance instruction plates, tags or decals must be changed accordingly.
- * 21) Care must be taken to assure that all replacement parts, including tires, are interchangeable with the original parts and of a quality at least equal to that provided in the original equipment. Parts, including tires are to be installed per the manufacturer's procedures. Always use genuine HYUNDAI or HYUNDAI-approved parts.
- * 22) When removing tires follow industry safety practices. Most importantly, deflate pneumatic tires completely prior to removal. Following assembly of tires on multi-piece rims, use a safety cage or restraining device while inflating.
- * 23) Use special care when removing heavy components, such as counterweight, mast, etc.. Be sure that lifting and handling equipment is of the correct capacity and in good condition.

9. MAINTENANCE GUIDE

1) SUPPLYING BRAKE FLUID

A hydraulically operated brake is employed. Check the level of brake fluid in the reservoir tank. When the level is low, refill.

- (1) Do not mix with different kinds of brake fluid.
- (2) Be careful not to allow external dust to enter through the reservoir cap vent hole and clog it.
- (3) Brake fluid change needs a special technique. When the change is necessary, go to the service station and ask for the change.

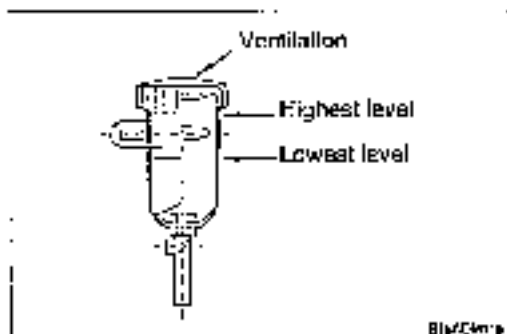

2) SUPPLYING HYDRAULIC OIL

Lower the fork in its lowest position on an even ground. Check for the hydraulic oil level with the oil level gauge. When the level is low, refill.

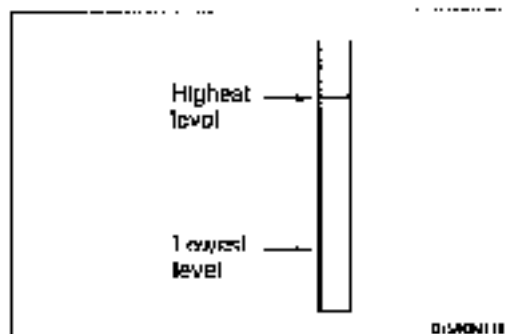

3) CHECKING AND ADJUSTMENT OF LIFT CHAIN TENSION

Set the fork in its horizontal position on an even ground. Raise it up to 20-30cm from the ground and push the chain with both hands. If the tension is too high or too low on one side, adjust it with the chain anchor bolt.

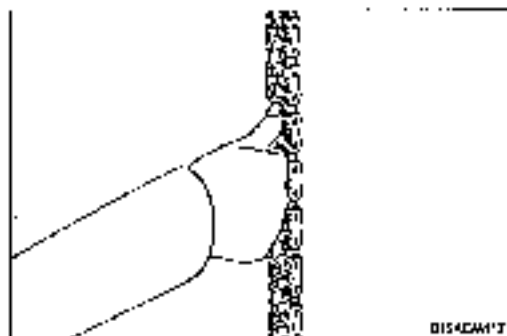

4) CHECKING OF HUB NUT TIGHTENING CONDITION

Make sure that the hub nut is firmly tightened.

Tightening and checking should be made in a diagonal order to prevent unbalanced tightening. (See the figure.)

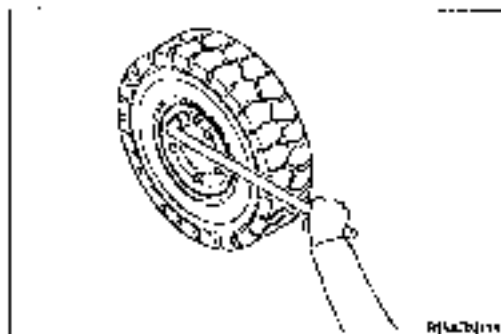

5) GREASING UP

Clean the following fittings with brushes or waste and apply grease to them.

△ Be careful not to supply too much grease.

Fittings	Greasing points
Mast support	2 spots
Tilt cylinder pin	2 spots / -
Link steering cylinder	4 spots / -
King pin	4 spots / -
Steering axle mounting	2 spots / -
Idle wheel bracket	2 spots

6) GREASING OF EACH PARTS

Clean the following parts before greasing.

- (1) Lift chain : Clean the chain with a brush greased with SAE 30-40(Brush over the gear oil low viscosity).
- (2) Rolling part of mast guide rail roller : Brush over grease
- (3) Slide guide and slide rail : Brush over leaked oil.
- (4) Sliding parts of inner mast and outer mast : Brush over leaked oil.
- (5) Sliding parts of fork and finger bar : Brush over grease.

7) CHECK FOR THE OIL LEVEL OF THE DRIVING GEAR CASE

Check for the oil level by taking out the plug provided front side of the gear case.

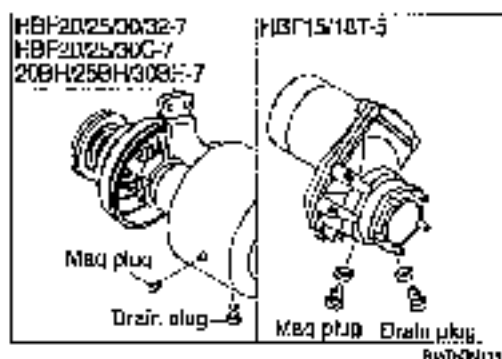

8) EXTERNAL APPEARANCE CHECK OF THE VEHICLE

Check for the external appearance of vehicles. If any defect is found immediately contact the service station.

9) FUSE REPLACEMENT

(1) Disconnect the battery connector.

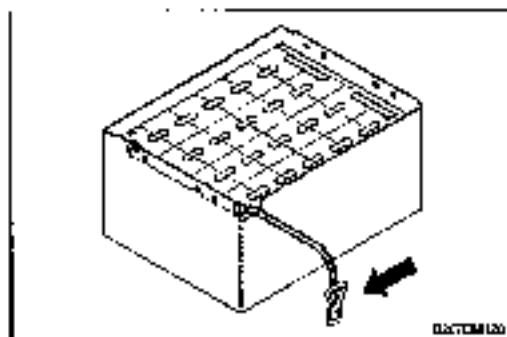

(2) Remove the blown fuse and replace with a new one.

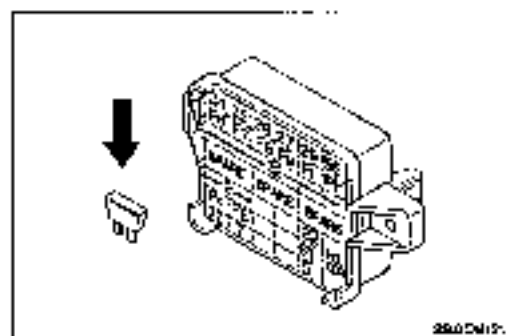

a. The blown fuse must be replaced with a fuse of the same capacity. When the fuses are often blown out contact the service station for inspection. Never use a conductor for a fuse.

10) LIFT CHAIN MAINTENANCE

The chain system on the mast was designed for safe, efficient and reliable transmission of lifting force from hydraulic cylinder to the forks, safe use of your truck with minimum down-time depends on the correct care and maintenance of the lift chains. Most complaints of unacceptable chain performance are a result of poor maintenance. Chains need periodic maintenance to give maximum service life.

A. Do not attempt to repair a worn chain. Replace worn or damaged chains. Do not place chains together.

11) LIFT CHAIN INSPECTION AND MEASUREMENT

Inspect and lubricate the lift chains every PM (50–250 hours). When operating in corrosive environments, inspect the chains every 50 hours. During the inspection, check for the following conditions:

- (1) Rust and corrosion, cracked plates, raised or turned pins, tight joints, wear and worn pins or holes.
- (2) When the pins or holes become worn, the chain becomes longer. When a section of chain is 3% longer than a section of new chain, the chain is worn and must be discarded.
- (3) Chain wear can be measured by using a chain scale or a steel tape measure. When checking chain wear, be sure to measure a segment of chain that moves over a sheave. Do not repair chains by cutting out the worn section and joining in a new piece. If part of a chain is worn, replace all the chains on a truck.

12) LIFT CHAIN LUBRICATION

Lift chain lubrication is an important part of your maintenance program. The lift chains operate under heavy loadings and function more safely and have longer life if they are regularly and correctly lubricated. HYUNDAI chain lubricant is recommended; it is easily sprayed on and provides superior lubrication. Heavy motor oil may also be used as a lubricant and corrosion inhibitor.

13) LIFT CHAIN WEAR AND REPLACEMENT CRITERIA

All chains must be replaced if any link has wear of 3% or more, or if any of the damaged conditions noted above are found during inspection. Order replacement chains from your HYUNDAI dealer. Replace all chains as a set. Do not remove factory lubrication or paint new chains. Replace anchor pins and worn or broken anchors when installing new chains. Adjust tension on new chains. Lubricate chains when they are installed on the mast.

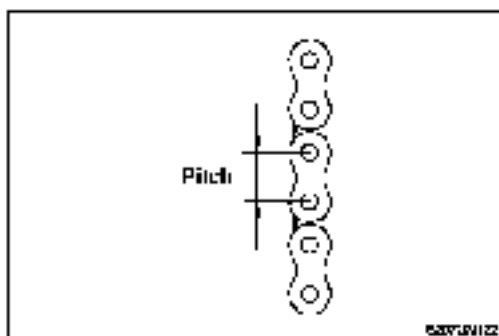

- ✦ Please refer to your Service Manual for additional information on lift chain measurement and maintenance.

10. VISUAL INSPECTION

First, perform a visual inspection of the lift truck and its components.

- Walk around the truck and take note of any obvious damage and maintenance problems. Check for loose fasteners and fittings.

- Check to be sure all capacity, safety, and warning plates or decals are attached and legible.

* **NAMEPLATES AND DECALS:** Do not operate a lift truck with damaged or lost decals and nameplates. Replace them immediately. They contain important information.

- Inspect the truck for any sign of external leakage: drive axle fluid etc.

- Check for hydraulic oil leaks and loose fittings.

▲ **HYDRAULIC FLUID PRESSURE:** Do not use your hands to check for hydraulic leakage. Fluid under pressure can penetrate your skin and cause serious injury.

- Be sure that the driver's overhead guard, load backrest extension and safety devices are in place, undamaged and attached securely.

Then check all of the critical components that handle or carry the load.

1) OVERHEAD GUARD

Check the overhead guard for damage. Be sure that it is properly positioned and all mounting fasteners are in place and tight.

2) LOAD BACKREST

Check the load backrest for damage. Inspect the welds on the carriage and load backrest for cracks.

Be sure that the mounting fasteners are all in place and tight.

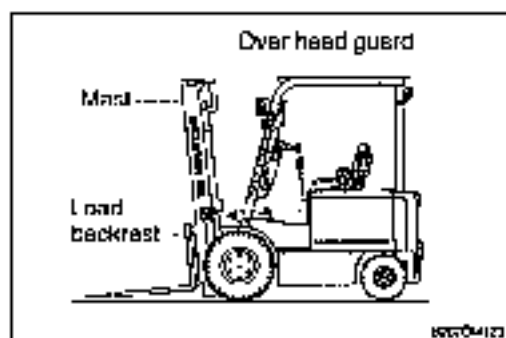

3) MAST ASSEMBLY

Inspect the mast assembly: Falls, carriage rollers, lift chains, lift cylinders and tilt cylinders. Look for obvious wear and maintenance problems and damaged or missing parts. Check for any loose parts or fittings. Check for leaks, any damaged or loose rollers and rail wear (metal flaking). Inspect all lift line hydraulic connections for leaks.

4) LIFT CHAIN

Carefully check the lift chains for wear, rust, corrosion, cracked or broken links, stretching, etc.. Check that the lift and carriage chains are adjusted to have equal tension. Check that the lift chain anchor fasteners and locking means are in place and tight.

▲ **Masts and lift chains require special attention to maintain them in safe operating condition.**

- Mast can drop suddenly. Look at the mast, but keep hands out.

- Lift chain repairs and adjustments should be made by trained service personnel.

5) FORKS

Inspect the load forks for cracks, breaks, bending, and wear. The fork top surfaces should be level and even with each other. The height difference between both fork tips should be no more than 3% of the fork length.

- ⚠ If the fork blade at the heel is worn down by more than 10%, the load capacity is reduced and the fork must be replaced.

Inspect the forks for twists and bends. Put a 2" thick metal block, at least 4" wide by 24" long with parallel sides, on the blade of the fork with the 4" surface against the blade. Put a 24" carpenter's square on the top of the block and against the shank. Check the fork 20" above the blade to make sure it is not bent more than 1" maximum.

- ⚠ If the fork blades are obviously bent or damaged, have them inspected by a trained maintenance person before operating the truck.

Inspect the fork locking pins for cracks or damage. Reinsert them and note whether they fit properly.

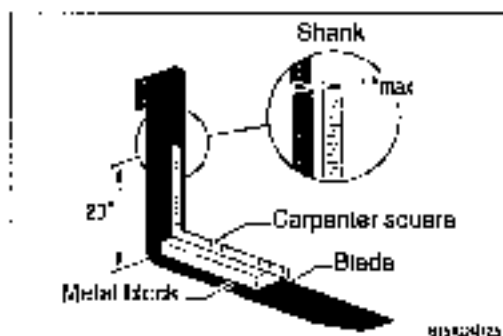
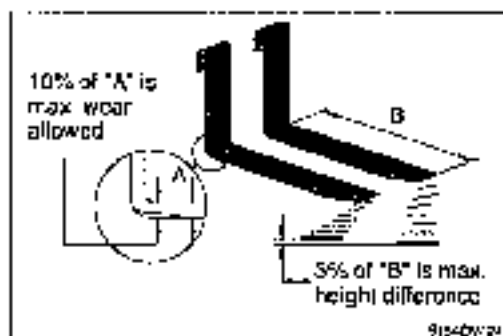

b) WHEELS AND TIRES

Check the condition of the drive and steering wheels and tires. Remove objects that are embedded in the tread. Inspect the tires for excessive wear and breaks or chunking out.

Check all wheel lug nuts or bolts to be sure none of them is loose or missing. Replace missing bolts or lug nuts. Torque loose or replaced items to specifications.

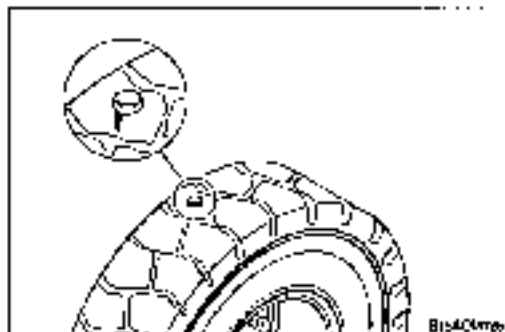

- ⚠ Check tire pressure from a position facing the tread of the tire, not from the side. Use a long-handled gauge to keep your body away from the side. If tires are low, do not operate and do not add air. Check with a mechanic. The tire may require removal and repair. Incorrect (low) tire pressure can reduce the stability of your lift truck. Do not operate truck with low tire pressure.

Model	Front	Rear
HBF2025-7 80BH/25BH-7	3.5kgf/cm ² (121 psi)	10.2kgf/cm ² (145 psi)
HBF3032-7 33BH-7	3.0kgf/cm ² (114 psi)	10.2kgf/cm ² (145 psi)

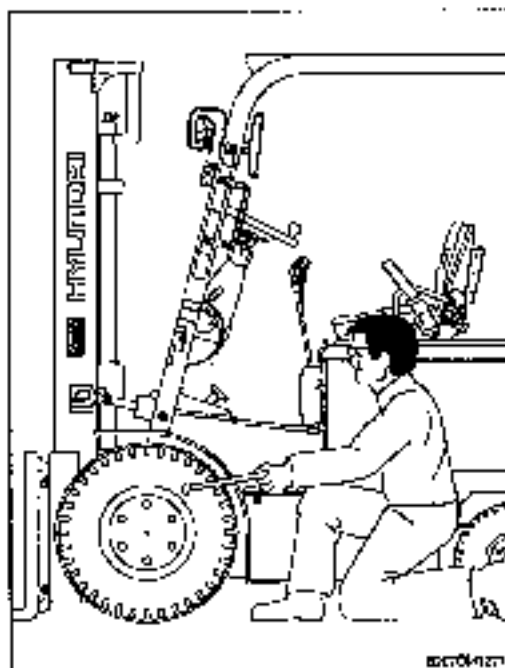

11. CHECKING THE HYDRAULIC FLUID

Check the hydraulic sump tank fluid level. Correct fluid level is important for proper system operation. Low fluid level can cause pump damage.

Hydraulic fluid expands as its temperature rises. Therefore, it is preferable to check the fluid level at operating temperature (after approximately 30 minutes of truck operation). To check the fluid level, first park the truck on a level surface and apply the parking brake.

Put the mast upright in a vertical position and lower the fork carriage fully down. Pull the dipstick out (under the sump breather), wipe it with a clean wiper, and reinsert it. Remove dipstick and check oil level. Keep the oil level above the LOW mark on the dipstick by adding recommended hydraulic fluid only, as required. Do not overfill.

When checking hydraulic oil, make sure you use a clean wiper and do not let contaminants get on the dipstick or in the sump.

Check the condition of the hydraulic fluid (age, color or clarity, contamination). Change (replace) the oil as necessary.

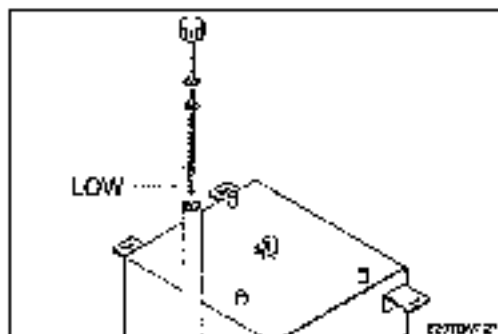

12. CRITICAL FASTENER CHECKS

Fasteners in highly loaded (critical) components can quickly fail if they become loosened. Also, loose fasteners can cause damage or failure of the component. For safety, it is important that the correct torque be maintained on all critical fasteners of components that directly support, handle or control the load and protect the operator.

Check critical items, including :

- Drive axle mounting
- Drive and steering wheel mounting
- Counterweight mounting
- Load backrest extension
- Overhead guard
- Tilt cylinder mounting & yokes
- Mast mounting & components

Refer to '8. SPECIFICATIONS' for critical tightening torque value.

13 AIR CLEANING THE TRUCK

Always maintain a lift truck in a clean condition. Do not allow dirt, dust, lint or other contaminants to accumulate on the truck. Keep the truck free from leaking oil and grease. Wipe up all oil spills. Keep the controls and floorboards clean, dry and safe. A clean truck makes it easier to see leakage and loose, missing or damaged parts. A clean condition helps prevent fires and helps the truck run cooler.

Lift trucks should be air cleaned at every PM interval and more often if needed.

Use an air hose with special adapter or extension having a control valve and a nozzle to direct the air properly. Use clean, dry, low pressure, compressed air. Restrict air pressure to 30 psi (207 kPa), maximum. (OSHA requirement.)

▲ Wear suitable eye protection and protective clothing.

Air clean : mast assembly; drive axle; battery; cables; switches and wiring harness; drive and hydraulic motors; and steering axle, steering cylinder and linkage.

14. ELECTRIC TRUCK BATTERY MAINTENANCE

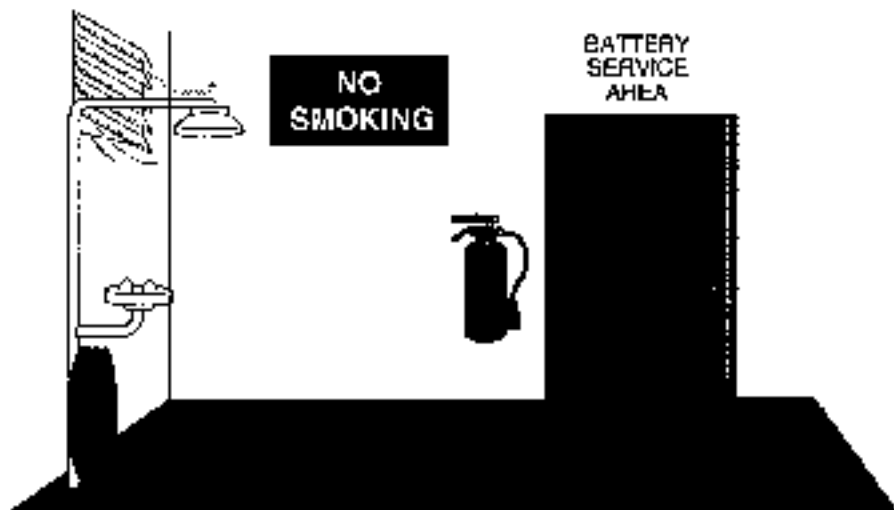

82624128

Battery charging installations must be located in areas designated for that purpose. These areas must be kept free of all non essential combustible materials.

Facilities must be provided for :

- Flushing spoiled electrolyte.
- Fire protection.
- Protecting charging apparatus from damage by trucks.
- Adequate ventilation for dispersal of fumes from gassing batteries.

When handling acid concentrates greater than 50 percent acid (above 1,400 specific gravity), an eye wash fountain must be provided.

A conveyor, overhead hoist or equivalent material handling equipment must be provided for handling batteries.

⚠ Electric truck batteries are heavy and awkward to handle. They are filled with a very hazardous chemical solution. On charge, they give off hydrogen and oxygen which, in certain concentrations, are explosive. And they are costly. Before you remove, service or install a truck battery, carefully read the following recommendations and instructions.

15. BATTERY HANDLING

- 1) Change (remove) or service storage batteries only in an area designated for this purpose.
- 2) Be sure this area has provisions to flush and neutralize spillage, to ventilate fumes from gassing batteries and for fire protection.
- 3) This area should be equipped with material-handling tools designed for removing and replacing batteries, including a conveyor or overhead hoist. Use lift hooks that have safety latches.
- 4) Always use a special lifting device such as an insulated spreader bar to attach the hoist to the battery. The width of the spreader bar hooks must be the same as the lifting eyes of the battery, to prevent damage to the battery. If the spreader bar hooks are movable, carefully adjust the position (width) of the hooks so that the pull is directly upward (vertical), and no side load or force (pressure) is exerted on the battery case. Be sure the lift hooks are the correct size to fit the lifting eyes of the battery.

- 5) If the battery does not have a cover of its own or has exposed terminals and connectors, cover the top with a non-conductive (insulating) material, e.g., a sheet of plywood or heavy cardboard, prior to attaching the lifting device.

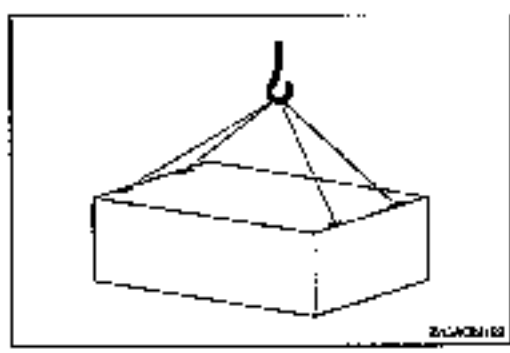

- 6) Chain hoists or power battery hoists must be equipped with loadchain containers to accumulate the excess lifting chain.
- 7) Keep all tools and other metallic objects away from the terminals.

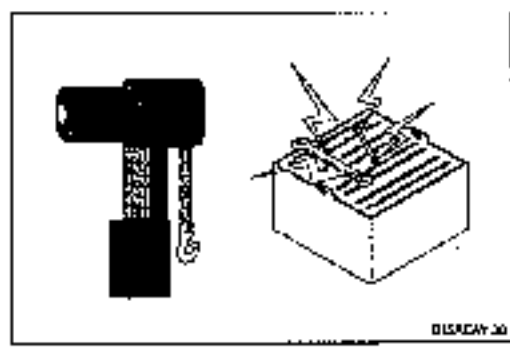

16 BATTERY CHARGING

The charger is of the automatic type so that only requirement for charging is to insert the plug, there being no need for maintaining watch.

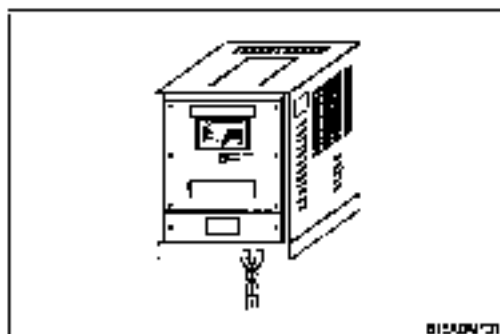

1) INSTRUCTION

(1) When inserting the plug and connecting the battery connector, the input power lamp and the battery connection lamp light on and charge is started after a few seconds. The power is automatically cut off after completion of charge.

(2) Functions

This function of indicator lamps and switches.

- ① **Input power lamp** : Only lighting on during charge. Check the plug and input power if the lamp does not light on.
- ② **Battery connection lamp** : Lighting on when the charger and the battery are connected. Check the connector if the lamp does not light on.
- ③ **75% charge lamp** : Lighting on from 75% charge to completion.
- ④ **Full charge lamp** : Lighting on when charging is completed.
- ⑤ **Input disconnect lamp** : Lighting on when the input supply line is disconnected. At this time, check the input power.
- ⑥ **Over voltage lamp** : Lighting on when the manual stop button is pushed or charger voltage is above 65. At this time, unplug and disconnect the battery and charger connectors.
- ⑦ **Over current lamp** : Lighting on when the current is overload. At this time, unplug, open charger door and push the thermal relay button on the electromagnetic switch, plug again after about 5 minutes and if this lamp lights on again, stop charging and call AVS.
- ⑧ **Ordinary/Equalizing charge convert switch** : Place the switch to left side for ordinary charge and to right side for equalizing charge.
- ⑨ **Manual stop button** : During charge, push this button to stop charging.
- ⑩ **Reversion button** : After stop charging artificially or push the manual stop button, see this button to revert to charging.
- ⑪ **Voltage/current confirming button** : The indicator always show battery voltage and when push this button, the current is displayed in the indicator.

2) INSTALLATION OF THE CHARGER

(1) Place for installation

Install the charger at a place with good ventilation, no excessive temperature, low humidity and little dust.

(2) For the primary of the transformer, use the taps corresponding to the power voltage difference. For example, $218V/(\text{measured value})-220V(\text{primary})$.

(3) Confirm the earth line of charging cable wire and make sure the earth line connects the earth of building.

3) ORDINARY CHARGE

(1) The procedure for charging is as follows:

- ① Remove the key of vehicle.
- ② Confirm the convert switch at ordinary charge position.
- ③ Connect the battery connector and the charging connector.
- ④ Make sure the pilot lamp lights.

(2) The procedure after completion of charging is as follows:

- ① Ensure that the full charge lamp lights on.
- ② Disconnect the battery connector from the charge connector.

(3) The procedure for stopping charging halfway is as follows :

- ① Push the manual stop button.
- ② Disconnect the battery connector from the charge connector.

4) EQUALIZING CHARGE

(1) Continual repetition of ordinary charge will create a certain amount of performance difference among the cells. For this reason, the battery is slightly overcharged from time to time to equalize the performance among the cells, that is, given equalizing charge.

Equalizing charge should be given in the following cases:

- ① A battery that is subject to daily repetition of charge and discharge. For the battery, equalizing charge should be performed once a month.
- ② When discharged over the designated capacity.
- ③ When recharge had been delayed after discharge.
- ④ When a short-circuit has occurred.

Equalizing charge is performed in the same way as in ordinary charge. However, place the ordinary/equalizing charge convert switch on the equalizing charge position.

△ Excessive equalizing charge may shorten the life of the battery.

5) SUPPLEMENTARY CHARGE

If one day operation cannot be completed with single charge, rest period should be utilized to charge and it is performed in almost the same way as ordinary charge.

6) NOTICES

- ① When installing the charger confirm the input voltage and use the taps corresponding to the power voltage in the area.
- ② Charge the battery immediately after use and once a month even in storage.
- ③ Take care not to let the battery specific gravity lower in winter time especially.
- ④ During charging, if electrolyte temperature of the battery is above 50°C stop charging.
- ⑤ During charging, as an inflammable gas is generated out of the battery, particular care should taken for fire and ventilation.

17. BATTERY REMOVAL FROM TRUCK

When the spare battery is used for continuous operation or it is required to check the battery, motor, etc., remove the battery through the following procedure:

- 1) Disconnect the battery connector.

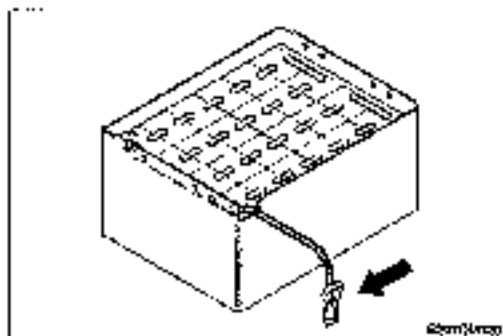

- 2) Release the battery hood catch.

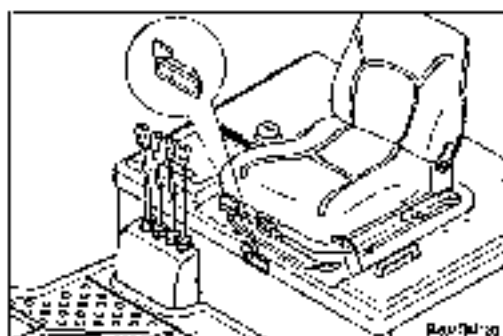

- 3) Open the battery cover.

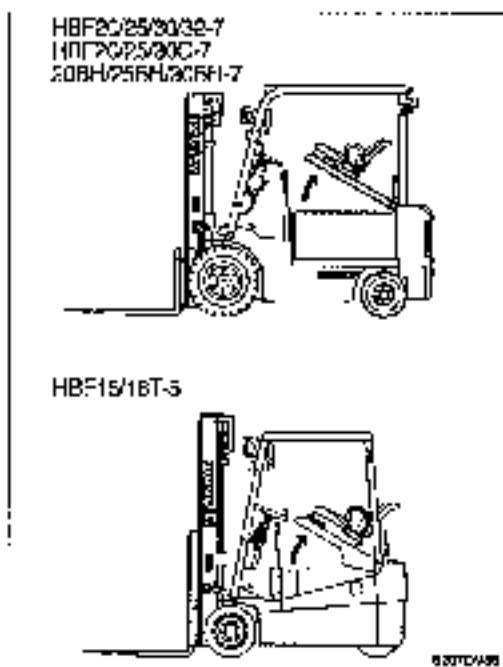

4) Remove the battery stopper.

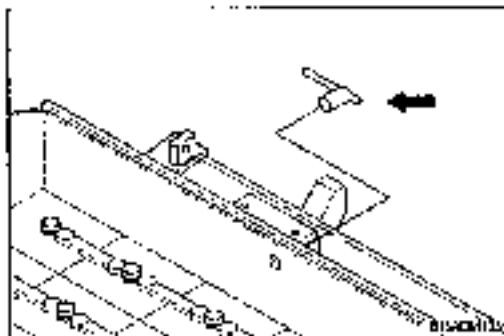

5) Pull down the battery with fork lift or chain block by hang up hook at 4 links which located in right and left of the battery.

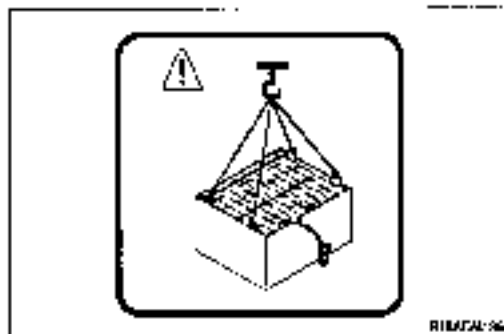

18. BATTERY CLEANING AND CARE

1) AVOID OVER-DISCHARGE

If used until the vehicle can no longer run, battery life will be shortened. If the battery capacity indicator's red lamp turns on all on load lift, stop operation and charge the battery without delay.

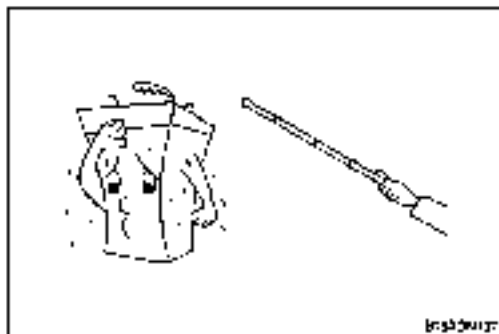

2) INFLAMMABLE

In any case, keep fire away from the battery because it contains an inflammable gas.



3) REFILLING DISTILLED WATER

Refill distilled water to maintain the electrolyte level to the specified height before starting equalizing charge, because electrolyte is lost through decomposition during charge and also through natural evaporation. It is unnecessary to refill dilute sulfuric acid into the battery except the case of losing electrolyte by running over.

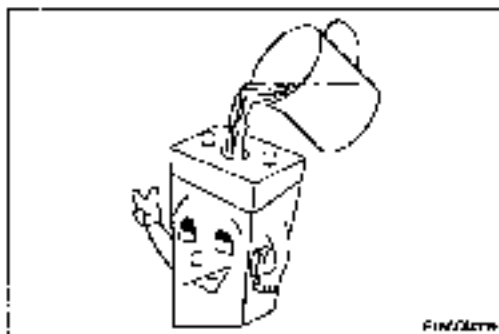

4) KEEP THE BATTERY CLEAN

Keep the battery, in particular the upper surface, clean and dry and keep the filler plugs tightly screwed.

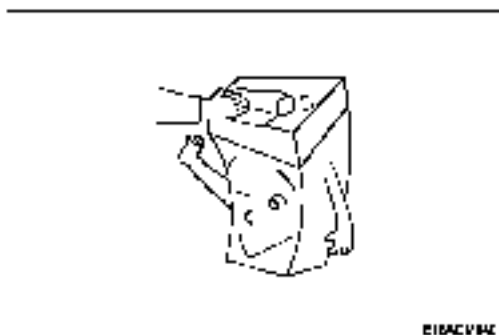

19. CONTROLLER SYSTEM

1) STRUCTURE

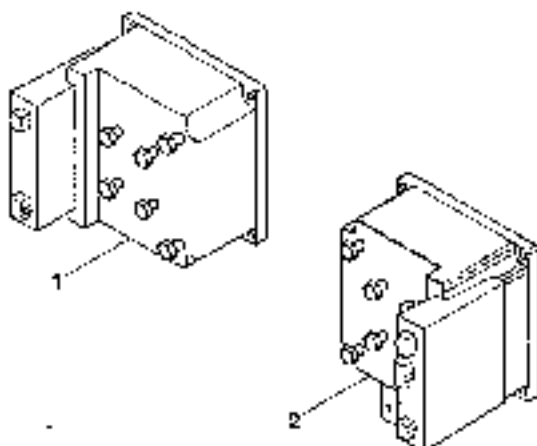

9/16/21

1 Traction controller

2 Pump controller

(1) Specifications

Model	Logic	Application	Type	Power	Actual value
HBF202530C2-7 HBF202530C-7	Medium I/O Logic	Traction	SERIES	24-48V, 650A	650A
	Pump I/O Logic	Pump	SERIES	24-48V, 650A	650A
HBF1518T-5 HBF141518-7	SEM low I/O Logic	Traction	SEM	24-48V, 350A/50A	350A
HBR2025-7	SEM low I/O Logic	Traction	SEM	24-48V, 425A/50A	420A
HBF1518T-5 HBF141518-7 HBR2025-7	Pump I/O Logic	Pump	SERIES	24-48V, 450A	400A
20BP25RH/30RH-7	Medium I/O Logic	Traction	SERIES	72-80V, 600A	600A
	Pump I/O Logic	Pump	SERIES	72-80V, 450A	450A

2) VARIANTS



01-16-000

1st digit (Controller type)	2nd digit (Voltage range)	3rd digit		Suffix
		SERIES	SEM	
2 = Traction	4 = 24 - 48V	3 = 300A	3 = 300A/50A*	L = Low I/O, Traction
3 = Pump	5 = 72 - 80V	4 = 450A	4 = 425A/50A*	M = Medium I/O, Traction
7 = SEM		8 = 650A		H = High I/O, Traction P = Low I/O, Pump

* Armature/Field

Model	Power	Configuration	Logic	No. of power terminal	Unit size
PP246M	24-48V 650A	Traction Heger/Pug	Med. I/O	8	142 x 142 x 140mm
PP344P	24-48V 450A	Pump	Pump. I/O	4	142 x 142 x 140mm
PP346P	24-48V 650A	Pump	Pump. I/O	4	142 x 142 x 140mm
PP743	24-48V 350A/50A	Traction SEM	Low I/O	6	142 x 142 x 140mm
PP784	72-80V 425A/50A	Traction SEM	Low I/O	6	142 x 142 x 140mm

3) CONTROLLER FEATURES WITH THE DIFFERENT LOGIC VARIANTS

(1) SERIES

Logic Feature	Pump Low VO Logic	Traction Mod. VO Logic
Number of connectors	2	8
Number of digital switch inputs	6	8
Number of analogue inputs	2	2
Number of contactor drive outputs(2 Amcs)	0	5
24V - 80V operation	YES	YES
Can cater for current limit range of 300A to 650A	YES	YES
Logic case enclosed to IP65, power case to IP35	YES	YES
Microprocessor control	YES	YES
High frequency (silent operation)	YES	YES
Internal watchdog monitoring microprocessor operation	YES	YES
Arrest contactor switching and built in coil suppression	N/A	YES
Use of 24V contactors at all voltages possible	N/A	YES
Low impedances, active low inputs switched to 0v	YES	YES
Thermally compensated current limit	YES	YES
Selectable anti-rattle characteristics	NO	YES
Adjustable creep speed	YES	YES
Bypass with over current dropout + field weakening	N/A	YES
Seat switch timer	N/A	YES
Beily switch operation	N/A	NO
Power steer contactor driver and timer	N/A	YES
Regenerative or plug brake only	N/A	YES
Braking proportional to accelerator position	N/A	YES
Braking in neutral	N/A	YES
Braking with brake pedal	N/A	YES
Under and over-voltage protection	YES	YES
Accelerator wire off detect	N/A	YES

Logic Feature	Pump Low VDC Logic	Traction Med. VDC Logic
Limiting and limited burst inching facilities	N/A	YES
Economy pot input	N/A	YES
Short circuit and open circuit contactor detect	N/A	YES
3 traction cutback speeds with independent escape delays	N/A	YES
8 Pump speeds with additive, priority & compensation	YES	N/A
Input to disable pump operation	YES	N/A
Independent power steer speed and compensation settings	YES	N/A
Hardware and software fail-safe systems	N/A	YES
+ 12V output pin	NO	YES
Diagnostic with LED indication	YES	YES
Adjustments made via a calibrator	YES	YES
Serial communications (external module gives RS232)	YES	YES
Can be setup with a PC (via above external module)	YES	YES
CAN serial communications	YES	YES
Hours count displaying key & pulsing hours on calibrator	YES	YES
BCD on calibrator	YES	YES
Dual motor non proportional variant with switches or pot	N/A	NO
Dual motor steer angles can be adjusted	N/A	NO
Dual motor independently ramp up/down delay adjustable	N/A	NO
Speed limit facility optionally available with speed sensor	N/A	YES
Resettable service and fault logs	YES	YES
Foreign languages selectable on calibrator	YES	YES
Standard 7 full feature dashboard display compatible	YES	YES
Setup menu on calibrator to enable various options	YES	YES

② SEM

Logic Feature	Powerpak
Logic	Separate
Number of contactors	2
Number of digital switch inputs	8
Number of analogue inputs	2
Number of contactor drive outputs	2
Voltage operation range	24-60V
Armature current limit range	350-500A
Field current limit range	30-60A
Armature and field currents independently measured	Yes
Solid state direction control	Yes
Good speed regulation without speed sensor	Yes
Motor curve setup menu	Yes
Armature to field current mapping adjustment	Yes
Case enclosed to IP20	Yes
Microprocessor control	Yes
High frequency (Silent Operation) Armature + Field	Yes
Internal watchdog monitoring microprocessor operation	Yes
24V contactors at all voltages possible + built in suppression	Yes
Low impedance, active low outputs switched to 5Vdc	Yes
Thermally compensated current limit	Yes
Selectable accelerator characteristics	Yes
Adjustable creep speed	Yes
Variable field weakening without contactor	Yes
Soft switch time	Yes
Belly switch operation	Yes
Line contactor drive	Yes

Logic Feature	Powerpak
Power steer contactor driver and limiter	Yes
Electric brake driver for wetlines	Yes
Regenerative braking down to zero speed	Yes
Braking proportional to accelerator position	Yes
Braking in neutral and with brake pedal	Yes
Under and over-voltage protection	Yes
Accelerator wire off detect	Yes
Inching and timed burst inching facilities	Yes
Economy pot input	Yes
2 traction cutback speeds with independent accel delays	Yes
Hardware and Software failsafe systems	Yes
• 12V output pin	Yes
Diagnoses with LED indication	Yes
Adjustments made via a calibrator	Yes
Serial communications (external module gives RS232)	Yes
Can be setup with a PC (via above external module)	Yes
CAN serial communications	Yes
Hours count displaying Key & Pushing hours on calibrator	Yes
BCD on calibrator	Yes
Dual motor proportional variant with switches or pot	Yes
Dual motor steer angles can be adjusted	Yes
Sensorless speed control	Yes
Resettable service and fault logs	Yes
Foreign languages selectable on calibrator	Yes
Standard + Full feature dashboard display compatible	Yes
Setup menu on calibrator to enable various options	Yes
Additional suppression for 2 external contactors	Yes

4) SAFETY

- (1) Electric vehicles can be dangerous. All testing, fault-finding and adjustment should be carried out by competent personnel. The drive wheels should be off the floor and free to rotate during the following procedures.
- (2) The powerpak controller contains a triple fail-safe system to give a high level of safety. If the diagnostic LED is not illuminated or flashes, the safety circuit may have tripped and the truck may not drive.
- (3) To ensure continued safety of the powerpak system, the fail-safe circuit should be checked whenever the truck is serviced. The period between checks should not exceed 3 months.

▲ The battery must be disconnected before replacing or attempting any repairs of the controls.

- (4) Before working on the controls disconnect the battery and connect the B⁺ and B⁻ controller terminals via a 10 ohm 25 watt resistor to discharge the internal capacitors.
- (5) Never connect the controller to a battery with its vent caps removed as an arc may occur due to the controller's internal capacitance when it is first connected.

(6) FAIL-SAFE CHECK

Ensure the drive wheels are clear of the floor and free to rotate.

- ① Switch on, select seat switch, release brake, select direction and (SI), the wheels should rotate
 - ② and the diagnostic LED should give a steady illumination.
Switch off, disconnect battery and connect the A and B terminals together with, at least, 10mm²
 - ③ cable. Ensure that no other fault that would allow drive is present.
Reconnect battery, switch on key with direction in neutral.
 - ④ The LED should stay off. Select a direction and check that the direction contactors do not close and the wheels do not rotate.
Switch off at key and remove the A/B- connection. Switch on at key, reselect the power-up
 - ⑤ sequence and check that the LED illuminates and the truck wheels rotate.
If the truck drives as described in ③ the controller is faulty and must be replaced.
- (7) As blow-out magnets are fitted to contactors (except 24V) ensure that no magnetic particles can accumulate in the contact gaps and cause malfunction. Ensure that contactors are wired with the correct polarity to their power terminals as indicated by the + sign on the top moduling.
 - (8) The powerpak controller must NOT be used with permanently connected on-board chargers or damage to the system may result.
 - (9) The SEM controller contains a triple fail-safe system to give a high level of safety. If the diagnostic LED is not illuminated or flashes, the safety circuit may have tripped and the truck may not drive.
 - (10) To ensure continued safety of the SEM system, the fail-safe circuit should be checked whenever the truck is serviced. The period between checks should not exceed 3 months.
 - (11) The battery must be disconnected before replacing or attempting any repairs of the controls.
 - (12) Before working on the controls disconnect the battery and connect the B⁺ and B⁻ controller terminals via a 10 ohm 25 watt resistor to discharge the internal capacitors.
 - (13) Never connect the controller to a battery with its vent caps removed as an arc may occur due to the controller's internal capacitance when it is first connected.

- (14) The controller must be used with a line contactor as indicated in the wiring diagrams.
- (15) As blow-out magnets are fitted to contactors(except 24V) ensure that no magnetic particles can accumulate in the contact gaps and cause malfunction. Ensure that contactors are wired with the correct polarity to their power terminals as indicated by the + sign on the top moulding.
- (16) The controller must NOT be used with permanently-connected on-board chargers or damage to the system may result.

5) TECHNICAL SPECIFICATIONS

(1) Electrical

(1) Voltage specifications

Model	Voltage	Nominal Battery	Absolute maximum operating voltage
PPx 4 x	48V Units	24 - 48V	14.5 - 75V
PPx 8 x	60V Units	72 - 80V	43 C - 100V

(2) Current specifications

Model	Power	Current limit (1 tri)†	Safe operating area (SOA)	Continuous current 1 hour rating. Unit mounted on an aluminum base-plate 730x380x10mm, at 20°C ambient.
PP344P	48V 450A	450A	30 - 80%	135A
PP216M PP348P	48V 650A	650A	30 - 80%	210A
PP74S	48V 650A	350A	30 - 80%	177A
PP704	60V 425A	425A	30 - 80%	167A

(3) Switching frequency

16kHz Traction / Regen / Pump Drive and 6kHz plug braking.

(4) Electrical isolation

Enclosure to any live part = 1kV. Controller Internal insulation specified at > 10kV @ 500V DC. Dielectric strength 1000V @ 50-Hz for 1Minute.

(5) Battery polarity

A Line contactor driven from the keyswitch, with a 2A diode in series with the coil, will prevent line contactor closure if the battery positive and negative connections are reversed.

(2) Environmental

(1) Protection-logic(Powerpak)

The enclosure is protected to IP66.

1st digit(6) = Protection against dust ingress.

2nd digit(6) = Protection against high pressure jets of water in any direction.

(2) Protection-power frame(Powerpak)

The enclosure is protected to IP55.

1st digit(5) = Limited dust ingress permitted.

2nd digit(5) = Protection against low pressure jets of water in any direction
Limited ingress permitted.

(3) Vibration

GG, 40 200Hz for 1 hour, in x, y and z planes.

(4) Operating temperature

-30°C to +40°C ambient around controller.

⑥ **Storage temperature**

-40°C to +70°C

⑦ **Humidity**

95% maximum, non-condensing

⑧ **Humidity resistance**

No functional defects after controller is left at 60°C and 100% humidity for one hour after freezer use (-30°C minimum)

⑨ **Halt**

Powerpak has been highly accelerated life tested.

(3) **Mechanical**

① **Unit size (all units)**

Length 142mm, width 142mm, height 140mm with logic fitted.

(Height is 86mm with logic unplugged)

② **Enclosure**

Aluminium die cast base-plate with ABS plastic injection moulded power frame and logic covers.

③ **Power connections**

Aluminium vertical power bushes for M8 connection. M8 for armature and field connection.

④ **Fixings**

4x M6 clearance holes.

⑤ **Weight**

1.8kg

(4) **Logic I/O specifications**

① **Switch/Digital inputs**

a. **Operation**

Active-low (The input becomes active when connected to battery negative.)

b. **Voltage range**

Low (Closed) -1.0 to +1.8V

High (Open) +4.5 to 150V (or open-circuit)

c. **Input impedance**

Max. resistance to ground for a "low" = 500Ω

Min. resistance to ground for a "high" = 2.7kΩ

⚠ Negative switch returns must be connected to controller B- terminal and not at battery negative.

② **Analogue inputs**

0-5V inputs available and 5K potentiometer 3V/5-0V inputs available.

Fully protected (pins and threshold sealable).

③ **Supply output**

An unregulated 1.12V, 5mA power supply is available for supplying accelerators, speed sensor etc.

④ **Contactors drives**

Maximum Current : 2A

Protection : Drives are protected against direct connection to B+ and B-.

Suppression : Coil suppression built in

Supply : Logic variant dependant, see wiring diagram

6) CONTROLLER WIRING AND CONNECTIONS

(1) Wiring

① Power connections

See power wiring diagrams for specific connections.

② Power wiring

Minimum cable sizes : Current limits up to 500A 35mm² and 650A 50mm² for SLH/E/S.

Current limits up to 270A 25mm² and 500A 35mm² for SEM.

③ Fuse ratings

Maximum fuse ratings : current limits up to 300A 325A (SERIES), 180A, 125A(SEM)

(Air break) 450A 500A (SERIES), 270A, 175A(SEM)

650A 700A (SERIES), 350A, 250A(SEM)

500A 325A(SEM)

(2) Light wiring connections

The following section details the connectors on the minimum, medium and high logics. The minimum logic has 2 connectors, 1 for the vehicle/contacter connections and 1 for serial communications. The medium I/O logic has 3 connectors, 1 for the vehicle connections, 1 for the contactor connections and 1 for serial communications. The high I/O logic also has 3 connectors in total, 1 for the vehicle connections, 1 for the contactor connections, and 1 for serial communications.

Pin No	Vehicle connector socket B Traction Mod. I/O Logic. 12 way molex connector 8 Digital I/Os 2 Analog I/Os 1+12V G/P.	Vehicle and panel connector socket B Pump low I/O logic 12 way molex connector 6 Digital I/Os 2 Analog I/Os No contactor drives	POWERPAK SEM vehicle & panel connector socket B 12 way molex connector. 6 digital I/Os 2 analog I/Os 2 contactor drives
1	Key SW	Key SW	Key SW
2	Fwd SW	Pump SW 3(TILT)	Fwd SW
3	Rev SW	Pump SW 4(OPTION)	Rev SW
4	FS1 SW	-	FS1/Brake SW
5	Seal SW	-	Seal/Tilt SW
6	-	-	Digital pin 6
7	-	-	Digital pin 7
8	Handbrake	-	Line contactor G/P
9	Footbrake	-	P.Sleeve/Flap/Brake/Flap pin 1 G/P G/P
10	Motor temp sensor	Motor temp sensor	Analogous I/P 0V - 5V
11	Accel	Accel 3V5-0V(Pump SW1)	Analogous I/P 3V5 - 0V
12	+12V G/P	+12V G/P	-12V G/P

Pin No	Power pack connector socket C Traction Med. I/O Injic 10 way molex connector 5 cont. Drives	Communications connector socket A All Injics 6 way molex connector RSP32 & CAN	POWERPAK Communications connector socket A 6 way molex connector CAN (External module allows RS232 connection to PC)
1	Cont. G/P	RS232 (X0)	+10V5
2	Fwd cont	0v	0V
3	Rev cont	RS232 (XK/TTL Lave)	NC
4	Regen cont	+10V5	+10V5
5	Bypass cont	CAN High	CAN High
6		CAN Low	CAN Low

(3) CAN (Controller Area Network)

This CAN system is defined as CAN 2.0A (Basic CAN, error active) and is implemented using a Philips Semiconductor chip-set with an 80C250 transceiver chip. The powerpak CAN protocol sets the baud rate to be 100k bits per second.

7) CALIBRATOR AND ADJUSTMENTS

A sophisticated, yet easy to use hand held adjustment unit, called the calibrator is used to make adjustments to the controller and select configurations. The calibrator is also used as a diagnostic tool displaying the status of all voltages, currents and temperatures within the controller together with the condition of all the controller's switch and analogue inputs.

The diagram below describes how the calibrator is used. The left and right arrows move between screens on the same level.

The up down arrows move between levels and the + and - buttons increment or decrement the parameters by the amount indicated in the STEP column of the following tables.

The calibrator can be specified to have various levels of access to certain adjustments.

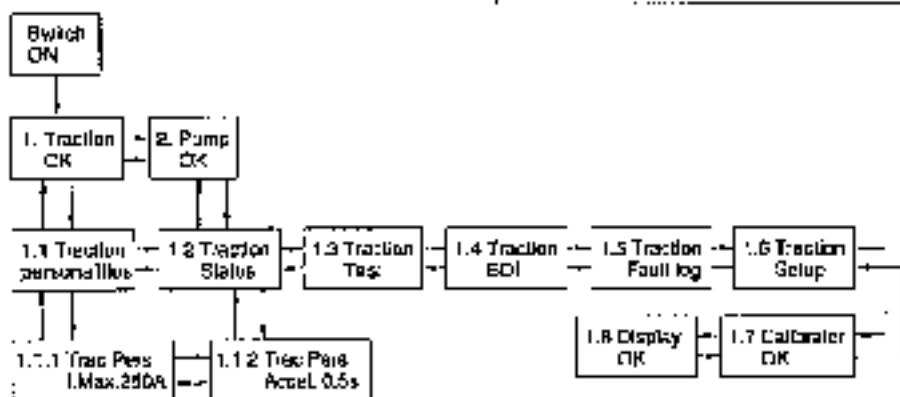
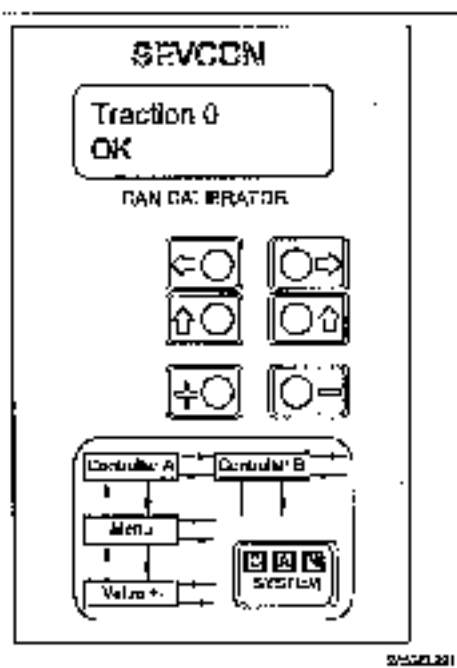

(1) Traction Controller Personalities (Controller Adjustments)

(1) SERIES

Cal. Ref.	Parameter Adjusted	Logic:	Min adjust (all units)	Max adjust (50A unit)	Step size (all units)	Actual value 1	Actual value 2
1.1.1	Current limit	Med Vb	50A	650A	10A	650A	500A
1.1.2	Acceleration delay	Med Vb	0.1S	5.0S	0.1S	1.0S	2.0S
1.1.2a	Current ramp delay	Med Vb	0.0	2.5S	0.1S	0.0S	0.0S
1.1.3	Deceleration delay	Med Vb	0.1S	0.5S	0.1S	0.1S	0.1S
1.1.4	Creep speed	Med Vb	0%	25%	1.0%	4%	3%
1.1.5	Direction plug current	Med Vb	50A	810A	10A	650A	550A
1.1.5a	Plug turn	Med Vb	50A	650A	10A	50A	-
1.1.6	Neutral plug current	Med Vb	10A(0 disables)	810A	10A	0A	0A
1.1.6a	Plugging threshold	Med Vb	50	25S	1	170	15S
1.1.6h	Plug creep	Med Vb	50A	650A	10A	100A	-
1.1.7	Footbrake plug current	Med Vb	10A(0 disables)	810A	10A	400A	550A
1.1.8	Direction regen current	Med Vb	50A	650A	10A	300A	250A
1.1.8a	Speed limit braking	Med Vb	40 A/KPH	650A	10A	40 A/KPH	40 A/KPH
1.1.9	Neutral regen current	Med Vb	10A(0 disables)	650A	10A	0A	0A
1.1.10	Footbrake regen current	Med Vb	10A(0 disables)	650A	10A	300A	300A
1.1.11	Regen delay	Med Vb	0mS(0 plug only)	350ms	10ms	150mS	150mS
1.1.12	Maximum speed	Med Vb	0%	100%	1.0%	100%	100%
1.1.13	Cutback speed 1	Med Vb	0%	100%	1.0%	100%	100%
1.1.14	Acceleration delay 1	Med Vb	0.1S	5.0S	0.1S	0.1S	0.1S
1.1.15	Cutback speed 2	Med Vb	0%	100%	1.0%	100%	100%
1.1.16	Acceleration delay 2	Med Vb	0.1S	5.0S	0.1S	0.1S	0.1S
1.1.17	Cutback speed 3	Med Vb	0%	100%	1.0%	25%	-
1.1.18	Acceleration delay 3	Med Vb	0.1S	5.0S	0.1S	2.5S	-
1.1.19	Inch speed	Med Vb	0%	25%	1%	10%	-
1.1.20	Burst inch delay	Med Vb	0.1S	5.0S	0.1S	2.0S	-
1.1.21	Bypass over current	Med Vb	10A(0 disables)	970A	10A	750A	750A
1.1.22	Bypass delay	Med Vb	0.5S	5.0S	0.1S	1.5S	1.5S
1.1.23	Field weak pull in	Med Vb	50A	650A	10A	50A	50A
1.1.24	Field weak pickup out	Med Vb	50A	650A	10A	50A	50A
1.1.25	Power steer delay	Med Vb	0S	60S	1.0S	3.0S	3.0S
1.1.26	Seat switch delay	Med Vb	0S	5.0S	0.1S	2.0S	2.0S
1.1.27	Electric brake delay	Med Vb	0S	5.0S	0.1S	2.0S	0.0S
1.1.28	Accelerator zero level	Med Vb	0V	5.0V	0.02V	3.20V	3.14V
1.1.29	Accelerator full level	Med Vb	0V	5.0V	0.02V	0.60V	0.32V
1.1.30	Footbrake pot zero level	Med Vb	0V	5.0V	0.02V	0.0V	-
1.1.31	Footbrake pot full level	Med Vb	0V	5.0V	0.02V	5.0V	-
1.1.32	Economy pot zero level	Med Vb	0V	5.0V	0.02V	0.1V	-
1.1.33	Economy pot full level	Med Vb	0V	5.0V	0.02V	3.7V	-

Actual value 1 : HBF15/18T-5, HBR14/15/18-7, HBR20/25-7, HBF20/25/30/32-7, HBF20/25/30C-7

Actual value 2 : 20BH/25BH/30BH-7

Cal. Ref	Parameter Adjusted	Logic :	Min adjust (all units)	Max adjust 650A unit	Step size (all units)	Actual value 1	Actual value 2
1.1.34	O.Temp cal zero level	Max /0	0V	5.0V	0.02V	3.00V	9.00V
1.1.35	O.Temp pot full level	Max /in	0V	5.0V	0.02V	4.50V	4.50V
1.1.36	Speed limit	Med /0	2kPH (0.000000)	80kPH	1kPH	0kPH	0.0PH
1.1.37	Low voltage inT	Med /0	14.5V	48/80V	0.5V	30V	50V
1.1.38	Low voltage outback	Med /0	14.5V	48/80V	0.5V	18V	49V
1.1.39	High voltage inT	Med /0	14.5V	75/100	0.5V	65V	87V
1.1.40	High voltage outback	Med /0	14.5V	75/100	0.5V	70V	97.5V
1.1.41	Protection delay	Med /0	0.5S	0.5S	0.1S	0.1S	0.1S
1.1.42	OTD timer	Med /0	0.1S	5S	0.1S	2S	2S

Actual value 1 : HBF15/18T-5, HBR14/15/18-7, HBR20/25-7, HBF20/25/30/32-7, HBF20/25/30C-7

Actual value 2 : 20BH/25BH/30BH-7

ε Depending on controller type and configuration some of the above may not be displayed.

Pressing the calibrator "down arrow" key from 1.1.2 allows access to 1.1.2a, likewise for 1.1.5a, 1.1.6a and 6b.

Pressing the calibrator "down arrow" key from the potentiometer zero and full personalities(1.1.27 to 1.1.32, and 2.1.24 to 2.1.27) jumps directly to the associated voltage measurement in the test menu. Pressing this key from the test menu jumps back to the associated zero level personality.

© SEM

Cal. Ref	Parameter Adjusted	Min adjust (all units)	Max. adjust (350A unit)	Step size all units	Actual value 1	Actual value 2
1.1.1A	Current limit amplitude	50A	350A	10A	350A	350A/420A
1.1.1F	Current limit field	10A	40A	1A	40A	50A
1.1.2	Acceleration delay	0.1S	5.0S	0.1S	3.0S	1.0S
1.1.3	Deceleration delay	0.1S	0.5S	0.1S	0.3S	0.1S
1.1.4	Creep speed	0%	25%	1.0%	2%	0%
1.1.5	Direction regen current	50A	350A	10A	150A	100A
1.1.5	Direction regen time	0.1S	5.0S	0.1S	1.5S	0.1S
1.1.6	Neutral regen current	10A(0 disable)	350A	15A	20A	10A
1.1.7	Footbrake regen current	10A(0 disable)	350A	15A	100A	0A
1.1.8	Regen delay	0	300ms	10ms	150ms	-
1.1.9	Threshold voltage	0.00V	3.20V	0.01V	0.40V	1.20V
1.1.10	Maximum speed	0%	100%	1%	100%	-
1.1.11	Roll off (etc)	1%(0 disable)	100%	1%	100%	-
1.1.12	Cutback speed 1	0%	100%	1%	70%	100%
1.1.13	Acceleration delay 1	0.1S	5.0S	0.1S	1.5S	1.5S
1.1.14	Cutback speed 2	0%	100%	1%	50%	100%
1.1.15	Acceleration delay 2	0.1S	5.0S	0.1S	1.5S	1.5S
1.1.16	Cutback speed 3	0%	100%	1%	100%	100%
1.1.17	Acceleration delay 3	0.1S	5.0S	0.1S	1.5S	1.5S
1.1.18	Inch speed	0%	25%	1%	0%	0%
1.1.19	Bus, inch delay	0.1S	5.0S	0.1S	1.0S	0.1S
1.1.20	Power steer delay	0S	60S	1.0S	5S	5S
1.1.21	Start switch delay	0S	5.0S	0.1S	2.0S	2.0S
1.1.22	Accelerator zero level	0.00V	5.00V	0.02V	3.30V	0.70V
1.1.23	Accelerator (u) level	0.00V	5.00V	0.02V	3.70V	3.30V
1.1.24	Footbrake pot zero level	0.00V	5.00V	0.02V	3.10V	3.50V
1.1.25	Footbrake pot full level	0.00V	5.00V	0.02V	4.80V	2.60V
1.1.26	Economy pot zero level	0.00V	5.00V	0.02V	2.50V	3.10V
1.1.27	Economy pot full level	3.00V	5.00V	0.02V	2.00V	4.80V
1.1.28	Steer pot left level	3.00V	5.00V	0.02V	1.80V	0.10V
1.1.29	Steer center	3.00V	5.00V	0.02V	3.80V	0.12V
1.1.30	Steer pot right level	0.00V	5.00V	0.02V	5.00V	4.00V
1.1.31	Dual motor inner angle	5°	80°	1.0°	25°	5°
1.1.32	Dual motor outer angle	10°	85°	1.0°	75°	75°
1.1.33	Constant speed	4.0KPH	6.0KPH	0.2KPH	5.8KPH	5.8KPH
1.1.34	Rally delay	0.5S	5.0S	0.1S	-	-
1.1.35	Speed limit	1.0KPH	51.0KPH	0.2KPH	5.0KPH	11.0KPH

Actual value 1 : For 350A(HBR15/18/5)

Actual value 2 : For 350A/420A(HBR14/15/18-7, HBR20/25-7)

Cpl. Ref	Parameter Adjusted	Min adjust (all units)	Max. adjust (350A unit)	Step size all units	Actual value 1	Actual value 2
1.1.26	Speed proportional	0(0 disables)	128	1	0	32
1.1.27	Brake proportional	0(0 disables)	128	1	32	92
1.1.28	Speed integral	0(0 disables)	16	1	0	9
1.1.29	Brake integral	0(0 disables)	16	1	9	9
1.1.40	Low voltage limit	14.5V	35V/48V	0.5V	30.0V	30.0V
1.1.41	Low voltage cutback	14.5V	35V/48V	0.5V	16.0V	16.0V
1.1.42	Protection delay	0.1S	2.5S	0.1S	0.5S	0.5S
1.1.43	High voltage limit	14.5V	50V/75V	0.5V	65.0V	65.0V
1.1.44	High voltage cutback	14.5V	50V/75V	0.5V	70.0V	70.0V
1.1.45	Foot delay	0S	60S	1S	5S	2S

Actual value 1 : For 350A(HBF15/18T5)

Actual value 2 : For 350A/420A(HBR14/15/18-7, HBR20/25-7)

Depending on controller type and configuration some of the above may not be displayed.

In speed control mode, deceleration delay has a maximum of 5.0S(all units).

Direction regen current is displayed in torque mode, and direction regen time is displayed in speed control mode.

Pressing the callibrator "down arrow" key from the potentiometer zero and full personalities(1.1.22 to 1.1.29) jumps directly to the associated voltage measurement in the test menu. Pressing this key from the test menu jumps back to the associated zero level personality.

(2) Traction Controller Status Information

Cal. ref.	Parameter displayed	Logic type	Min display	Max display	Step size	Log info	
1.2.1	Battery voltage	Med/lo	0V	127V	0.1V	+	
1.2.2	Traction motor voltage	Med/lo	0V	127V	0.5V		
1.2.3	Traction motor current	Med/hi	0A	1200A	1A	+	
1.2.4	Traction controller temp	Med/lo	-30°C	+225°C	1°C	+	
1.2.5	Traction motor voltage	Med/lo	0V	127V	0.5V		
1.2.6	Capacitor voltage	Med/lo	0V	127V	0.5V		
1.2.7	Speed sensor indication	Med/lo	0 KPH	60 KPH	1.0 KPH		
1.2.8	Key switch hours count	Med/lo	0 Hrs	65278.9 Hrs	0.1 Hrs		
1.2.9	Traction pulsing hours count	Med/lo	0 Hrs	65278.9 Hrs	0.1 Hrs		
1.2.10	CANbus status	Med/lo	0 Hrs	65278.9 Hrs	0.1 Hrs		
-	Service log reset	Med/lo	Press + followed by - to reset service log				

≡ Log info shows where the + and - keys can be used to access the service max and min data.

(3) Traction Controller Test Information

Cal. ref.	Input displayed	Logic type	Min display	Max display	Step size	
1.3.1	Accelerator %	Range	Med/lo	0%	100%	1%
1.3.2	Accelerator voltage	Range	Med/lo	0.0V	5.5V	0.02V
1.3.3	Footbrake pot. %	Range	Med/lo	0%	100%	1%
1.3.4	Footbrake pot. voltage	Range	Med/lo	0.0V	5.5V	0.02V
1.3.5	Economy pot. %	Range	Med/hi	0%	100%	1%
1.3.6	Economy pot. voltage	Range	Med/hi	0.0V	5.0V	0.02V
1.3.7	Forward	Switch	Med/lo	Open	Closed	-
1.3.8	Reverse	Switch	Med/lo	Open	Closed	-
1.3.9	FS1	Switch	Med/lo	Open	Closed	-
1.3.10	Belly	Switch	Med/lo	Open	Closed	-
1.3.11	Seat	Switch	Med/lo	Open	Closed	-
1.3.12	Tiler	Switch	Med/lo	Open	Closed	-
1.3.13	Speed cutback 1	Switch	Med/lo	Open	Closed	-
1.3.14	Speed cutback 2	Switch	Med/lo	Open	Closed	-
1.3.15	Speed cutback 3	Switch	Med/lo	Open	Closed	-
1.3.16	Inch forward	Switch	Med/lo	Open	Closed	-
1.3.17	Inch reverse	Switch	Med/lo	Open	Closed	-
1.3.18	Handbrake	Switch	Med/lo	Open	Closed	-
1.3.19	Footbrake	Switch	Med/lo	Open	Closed	-
1.3.20	Power steer trigger input	Switch	Med/lo	Open	Closed	-
1.3.21	Pump contactor trigger	Switch	Med/lo	Open	Closed	-
1.3.22	Speed encoder	Data	Med/lo	Low	High	-
1.3.23	Software version/revision		Med/lo	000.00	999.99	-
1.3.24	Controller serial number		Med/lo	00000000	99999999	-

≡ As with the personalities, only relevant switch tests will be shown determined by configuration.

(4) BDI Adjustments(If enabled in setup menu)

Cal. SERIES	Ref. SEV	Parameter adjusted/Displayed	Logic type	Min. setting	Max. setting	Step size	Actual value
1.4.1	1.4.1	xxx % Charge left	L, M, H, P	Display only			
1.4.2	-	Battery volt xxx V	L, M, H, P	24V	08V	2V	Nominal V
1.4.3	1.4.2	Reset xxx Volt	L, M, H, P	2.00V/Cell	2.50V/Cell	0.01V/Cell	2.15V 2.00V
1.4.4	1.4.3	Empty xxx Volt	L, M, H, P	1.50V/Cell	1.90V/Cell	0.01V/Cell	1.80V 1.55V
1.4.5	1.4.4	Warning xxx %	L, M, H, P	0%	90%	1.0%	20%
1.4.6	1.4.5	CutOut xxx %	L, M, H, P	0%	90%	1.0%	10%

(5) BDI(Battery Discharge indicator) setup

When the battery is deemed fully discharged all segments will be extinguished, with each 10% drop in capacity extinguishing 1 segment.

When the battery charge drops below an adjustable warning level, typically set to 20%, the remaining lit segments will flash to warn the driver of this. When the charge drops further to below an adjustable cut-out level, typically 10%, all 10 segments will flash. At the cut-out level, pump operation will be inhibited at the end of its present operating cycle, and outback 2 personalities will be applied to the traction.

When the battery is localized and the operation time of the truck is remarkably short, please check BDI DATA, especially empty level and adjust it properly.

There are 4 adjustments associated with the BDI, adjustable by the hand held calibrator as following :

* () shows BDI set of pump controller side.

① Charge remaining xxx%

Displays remaining battery charge. Display only, no adjustments can be made. After fully battery charged, it should display 100% remaining charge.

② Battery volt xxxV

Displays battery voltage. Display only, no adjustments can be made.

③ Reset level xxx volt/cell

The BDI will be reset to 100% remaining charge when the actual battery voltage is greater than an adjustable threshold. The customer should measure the cell voltage after charging, and set the threshold just below this. A reset can only occur just after key on, so adjustments of the threshold will only take effect if the key switch is cycled. If the value set 2.15V then $2.15V \times 24$ batteries = 51.6V. All 10 segments will be ON(reset) if the battery voltage exceed 51.6V. If the value set is too low then all 10 segments will be ON(reset) whenever key recycle. If the value set is too high then all segments will not turn ON(reset) even though the battery is fully charged. The value set only works to decide to turn ON(reset) all 10 segments after charging. It is nothing to do with battery discharging indication.

a. Measure the battery voltage after charging displayed on screen(②) battery volt.

b. Divide the battery voltage into cell numbers(=cell voltage).

c. Subtract 0.05 from cell voltage

d. Set the result on screen (③) reset level

Ex. If measured battery voltage is 51.35, the cell voltage is $51.35/24=2.14$. Therefore the result is $2.14-0.05=2.09$. Set 2.09 on screen (③) reset level.

④ Empty level

The battery discharging indication will fully depend on this threshold value. The controller uses this threshold value and internal timer to decrease the indication level. The discharge timer only counts "moderate discharge" - i.e. when the battery voltage is below a discharge threshold.

This threshold is calculated by adding an offset to the empty cell voltage. This offset decreases linearly with remaining charge. The value is typically 1.60V as a factory setting. If the value sets higher than 1.60V then the BDI segment will drop quickly. If it sets lower than 1.60V then the BDI segments remains longer. There may be inaccuracy of the BDI operation because of the difference of battery manufacture, nominal temperature etc. In this case, increase/decrease this threshold value to correct BDI but the specific gravity have to be checked to make sure the battery is fully discharged when the (D) indicates 20%. For example, the factory setting value is 1.60V. If the battery is fully discharged then the specific gravity is 1.160 when (D) indicates 20%. If the threshold value is too low then the specific gravity will be dropped more. Then, it will shorten the battery life cycle if the truck driver uses the battery up to 0% of battery segments.

When the remaining charge is reached 20% displayed on screen (D) measure the gravity of battery. If the gravity is checked 1.160/25°C, the empty level set up is not necessary.

- a. If the gravity is higher than 1.160/25°C, set the (D) Empty level down 0.03-0.05.
 - b. If the gravity is lower than 1.160/25°C, set the (D) Empty level up 0.03-0.05.
- x. When checking the gravity, refer to the battery manual for conversion rate of gravity by temperature variation. Normally, Gravity at 25°C = checked gravity + 0.007 (checked temperature -25).

⑤ Warning level %

Sets the discharged level at which the warning threshold is reached, at which point the remaining lit segments flash.

⑥ Cutout level %

Sets the discharged level at which the cut-out threshold is reached, at which point all the segments flash together and the cut-out action, pump cut-out and traction speed 2 is initiated.

To confirm the setup values, repeat the upper BDI setup procedure after fully battery charged.

(6) Fault Log

Can be disabled via setup menu.

7) TRACTION SETUP MENU (ENABLES/DISABLES FEATURES)

Ⓞ SERIES CONTROLLER

Cal. Ref.	Feature	Logic type	DC 24, 48 V	DC 60 V
1.6.1	Contactor chopping	L, M, H	Off	←
1.6.2	Accelerator type	L, M, H	Curved	←
1.6.3	BDI	L, M, H	On	←
1.6.4	Power steer trigger	L, M, H	1'S1 dir	F + D
1.6.5	Economy cuts traction current	M, H	On	•
1.6.6	Bypass in current limit	M, H	On	←
1.6.7	SRD	L, M, H	On	←
1.6.8	Braking	L, M, H	Constant	←
1.6.9	Plugging style	L, M, H	Constant current	←
1.6.10	Ride-on/walking truck	F, M, H	Fail-on	←
1.6.11	Filler switch	L, M, H	Off	←
1.6.12	Digital I/p 5 config (Skt B pin 6)	M, H	Speed 1	Speed 2
1.6.13	Digital I/p 6 config (Skt B pin 7)	M, H	Speed 2	Handbrake
1.6.14	Digital I/p 7 config (Skt B pin 8)	M, H	Handbrake	Speed 1
1.6.15	Digital I/p 8 config (Skt B pin 9)	M, H	Footbrake	←
1.6.16	Analog I/p 1 config (Skt B pin 10)	L, M, H	Accelerator pot	O Temp
1.6.17	Analog I/p 2 config (Skt B pin 11)	L, M, H	O Temp	Accelerator
1.6.20	Contacteur 3 config. (Skt C pin 4 MedHi I/O)	L, M, H	Med I/O logic regem	←
1.6.21	Contacteur 4 config (Skt C pin 5)	M, H	Bypass	←
1.6.22	Contacteur 5 config (Skt C pin 6)	M, H	Power steering	Diag LED
1.6.25	Serial switch cuts pump	M, H	Off	←
1.6.26	Fault log	L, M, H	On	←
1.6.27	Service log	L, M, H	On	←
1.6.28	Full speed	M, H	20kph	←
1.6.29	Probe frequency	M, H	100Hz	←
1.6.30	Mode	L, M, H	CAN master	•
1.6.31	Switch limits speed	L, M, H	OFF	•

← Changes only take effect after a key-switch recycle.

⊗ SEM CONTROLLER

Cal. Ref.	Feature	Options
1.6.1	System setup	Standalone / Master / Slave / Dual tractor / Traction + pump / Dual + pump
1.6.2	Digital ID	-
1.6.3	Analogous IP	-
1.6.4	Connector chopping	24V / On / Off
1.6.5	Accelerator type	Linear / Curved / 2° Slope / Crawl
1.6.6	BCI	On / Off
1.6.7	Power steer trigger	None to FS1 - Drive - Brake + Seat
1.6.8	Economy cuts traction current	On / Off
1.6.9	BSO	On / Off
1.6.10	Braking	Proportional / Constant
1.6.11	Control trace	Torque / Speed
1.6.12	Tiller up forward	On / Off
1.6.13	Hault log	On / Off
1.6.14	Service log	On / Off
1.6.15	Vehicle full speed	0.0KPH to 51.0KPH
1.6.16	Steer reverse enable	Yes / No
1.6.17	Roll off E. Brake	On / Off
1.6.18	Battery volt	24V to 36V(2V steps)
1.6.19	Seat & Pump	On / Off
1.6.20	Analog as digital configuration	NOpen / NClosed

* Changes only take effect after a key-switch recycle.

⊗ MOTOR

Cal. Ref.	Parameter adjusted	Min adjust (all units)	Max adjust (all units)	Step size (all units)	Typical Default (200A, 270A, 350A, 500A)
1.7.1	Armature current low	10A	50% of max	10A	50A (all units)
1.7.2	Field current low	0.00A	50% of max	0.25A	0.03a (all unit)
1.7.3	Armature current mid	Is Low	Is High	10A	100A 140A 170A 250A
1.7.4	Field current mid	If Low	If High	1A	13A 15A 25A 25A
1.7.5	Armature current high	50% of max	Maximum	10A	200A 270A 350A 500A
1.7.6	Field current high	50% of max	Maximum	1A	30A 30A 50A 50A
1.7.7	Armature resistance	0m Ω	255m Ω	1r Ω	30m Ω
1.7.8	Field resistance*	0.25 Ω	2.50 Ω	0.01 Ω	0.50 Ω

* Important Note : The correct field resistance personality for the SEM motor must be entered at item 1.7.8 for the motor to be controlled correctly

Cal. Ref.	Feature	Options
1.8.1	Main hours	Key / Drv / Prep
1.8.2	Status	Off / Trac V / Pump V / Pump V / KPH / MPH / Accel / Steer / Var No
1.8.3	Contrast	1 to 127 (increment steps of 1)
1.8.4	Trd 1	Off / Trac V / Trac V / Pump V / Pump V / KPH / MPH / Accel
1.8.5	Trd 2	Off / Trac V / Trac V / Pump V / Pump V / KPH / MPH / Accel / Steer
1.8.6	Trd 3 mega	Off / On

(B) Pump controller personalities(controller adjustments)

Cal. ref.	Parameter adjusted	Logic type	Min adjust (adj units)	Max adjust (50A unit)	Step size (adj units)	Actual value 1	Actual value 2	Actual value 3	Actual value 4
2.1.1	Current limit	P	50 A	650 A	10 A	650A	400A	100A	350A
2.1.2	Ramp up delay	P	0.1 S	5.0 S	0.1 S	1.0 S	0.1 S	0.1 S	1.0 S
2.1.3	Ramp down delay	P	0.1 S	0.5 S	0.1 S	0.1 S	0.1 S	0.1 S	0.1 S
2.1.4	Creep speed	P	0%	25%	1.0%	3%	0%	5%	3%
2.1.5	Pump speed 1	P	0%(0-inhibit)	100%	1.0%	100%	100%	0%	100%
2.1.6	Pump compensation 1	P	1%(0 disables)	200%	1.0%	200%	100%	50%	200%
2.1.7	Pump speed 2	P	0%(0-inhibit)	100%	1.0%	0%	0%	60%	0%
2.1.8	Pump compensation 2	P	1%(0 disables)	200%	1.0%	0%	0%	80%	0%
2.1.9	Pump speed 3	P	0%	100%	1.0%	70%	100%	100%	70%
2.1.10	Pump compensation 3	P	1%(0 disables)	200%	1.0%	150%	150%	200%	150%
2.1.11	Pump speed 4	P	0%	100%	1.0%	70%	50%	60%	70%
2.1.12	Pump compensation 4	P	1%(0 disables)	200%	1.0%	150%	100%	100%	150%
2.1.13	Pump Speed 5	P	0%	100%	1.0%	100%	0%	80%	100%
2.1.14	Speed 5(Priority/additive)	P	Priority	Additive	-	Priority	Priority	Priority	Priority
2.1.15	Pump speed 6	P	0%	100%	1.0%	100%	0%	0%	0%
2.1.16	Speed 6(priority/additive)	P	Priority	Additive	-	Priority	Priority	Priority	Priority
2.1.17	Pump speed 6	P	0%	100%	1.0%	0%	0%	0%	0%
2.1.18	Speed 6(priority/additive)	P	Priority	Additive	-	Priority	Priority	Priority	Priority
2.1.19	Power steer speed	P	0%	100%	10%	8%	6%	0%	8%
2.1.20	Power steer compensation	P	1%(0 disables)	200%	10%	60%	80%	0%	80%
2.1.21	Power steer ramp up delay	P	0.1 S	5.0 S	0.1 S	0.1 S	0.1 S	0.1 S	0.1 S
2.1.22	Power steer ramp-down delay	P	0.1 S	0.5 S	0.1 S	0.1 S	0.1 S	0.1 S	0.1 S
2.1.23	Power steer delay	P	0 S	60 S	1 S	2.0 S	2 S	2 S	2 S
2.1.24	Best switch delay	P	0 S	5 S	0.1 S	2.0 S	0.0 S	2.0 S	0.0 S
2.1.25	Accelerator zero level	P	0.0 V	5.0 V	0.02 V	4.20 V	4.30 V	0.10 V	3.94 V
2.1.26	Accelerator full level	P	0.0 V	5.0 V	0.02 V	2.30 V	2.80 V	3.40 V	3.14 V
2.1.27	Accelerator 2 zero level	P	0.0 V	5.0 V	0.02 V	3.00 V	0.0 V	3.30 V	3.00 V
2.1.28	Accelerator 2 full level	P	0.0 V	5.0 V	0.02 V	4.50 V	2.66 V	0.74 V	4.50 V
2.1.29	Low voltage int	P	14.5 V	48V for 24-48V units		30.0 V	30.3 V	38.0 V	50.0 V
2.1.30	Low voltage cutback	P	14.5 V	48V for 24-48V units		18.0 V	18.0 V	18.0 V	43.0 V
2.1.31	High voltage int	P	14.5 V	75V for 24-48V units		85.0 V	85.0 V	65.0 V	97.0 V
2.1.32	High voltage cutback	P	14.5 V	75V for 24-48V units		70.0 V	70.0 V	70.0 V	97.5 V
2.1.33	Battery protection	P	14.5 V	48V for 24-48V units		15.0 V	14.5 V	15.0 V	43.0 V
2.1.34	Protection delay	P	0.1 S	2.5 S	0.1 S	0.5 S	0.5 S	0.5 S	0.1 S

Actual value 1 : HBF20/25/30/32-7, HBF30/25/30C-7

Actual value 2 : HBF15/18T-5

Actual value 3 : HBR14/15/18-7, HBR20/25-7

Actual value 4 : 20BH/25BH/30BH-7

(9) Pump controller status information

Cal. ref.	Parameter displayed	Logic type	Min setting	Max setting	Step size	Default
2.2.1	Battery voltage	P	0V	~27V	0.5V	*
2.2.2	Pump motor voltage	P	0V	~27V	~V	
2.2.3	Pump motor current	P	0A	1200A	5 A	*
2.2.4	Pump inlet voltage	P	0V	127V	0.5V	
2.2.5	Pump controller temp.	P	-30°C	+225°C	1°C	-
2.2.6	Key switch hours count	P	0Hrs	65279.9Hrs	0.1Hrs	
2.2.7	Pump pulsing hours count	P	0Hrs	65279.9Hrs	0.1Hrs	
	Service log reset	P	Press + Followed by - to reset service log			

* Log info shows where the + and - keys can be used to access the service max and min. data.

(10) Pump Controller Test Information

Cal. ref.	Input displayed	Logic type	Min display (all units)	Max display (all units)	Step size (all units)
2.3.1	Accelerator 1% range	P	0%	100%	1%
2.3.2	Accelerator 1 voltage range	P	0.0V	5.0V	0.1V
2.3.3	Accelerator 2% range	P	0%	100%	1%
2.3.4	Accelerator 2 voltage range	P	0.0V	5.0V	0.1V
2.3.5	Pump switch 3	P	Open	Closed	-
2.3.6	Pump switch 4	P	Open	Closed	-
2.3.7	Pump switch 5	P	Open	Closed	-
2.3.8	Pump switch 6	P	Open	Closed	-
2.3.9	Pump switch 7	P	Open	Closed	-
2.3.10	Pump steer trigger	P	Open	Closed	-
2.3.15	Software version/navigation	P	000.00	999.99	
2.3.18	Controller serial number	P	00000000	99999999	-

(11) Pump BDI

Cal. Ref. SETTES	Parameter adjusted/displayed	Logic type	Min. setting	Max. setting	Step size	Actual vs ue
1.4.1	xxx % Charge left	L, M, H, P	Display only			
1.4.2	Battery volt xx V	L, M, H, P	24V	96V	2V	72-80V
1.4.3	Reset xxx V/cell	L, M, H, P	2.30V/Cell	2.50V/Cell	0.01V/Cell	2.15V
1.4.4	Empty xxx V/cell	L, M, H, P	1.50V/Cell	1.99V/Cell	0.01V/Cell	1.60V
1.4.5	Warning xx %	L, M, H, P	0%	90%	1.0%	20%
1.4.6	Critical xx %	L, M, H, P	0%	90%	1.0%	10%

(12) Pump fault log(as traction (5))

(13) Pump setup menu enables / disables features

① Setup

Cal. ref.	Feature	Logic type	Actual value
2.6.1	Mode	P	CAN bus
2.6.2	Accelerator type	P	Curved
2.6.3	Accelerator 2	P	Lit
2.6.4	EDI	P	ON
2.6.5	Fault log	P	ON
2.6.6	Service log	P	ON
2.6.7	Seat and pump	P	OFF
2.6.8	Pin 5	P	P.S.W. 0
2.6.9	Pin 6	P	P.S.W. 1
2.6.10	Pin 7	P	Motor lamp
2.6.11	Power steering active sense	P	Closed

≠ Changes only take effect after a key switch recycle.

② Display

Cal. Ref.	Feature	Actual value
2.7.1	Main hours	Key
2.7.2	Status	Off
2.7.3	Contrast	35
2.7.4	Ind 1	Off
2.7.5	Ind 2	Off
2.7.6	Fault mags	Off

(14) Traction and Pump adjustment descriptions

Adjustment	Logic type	Description (T-Affects traction, P-Affects pump)
Current limit	L, M, H, P	Maximum allowable motor current.
Acceleration delay	L, M, H, P	Time taken to ramp up from 0 to 100% on.
Current Ramp delay	L, M, H	Time taken to ramp up current on plugging and drive.
Deceleration delay	L, M, H, P	Time taken to ramp down from 100% to 0% on.
Crawl speed	L, M, H, P	Minimum applied % on when drive first selected. Only PS 1 on pump.
Dir. brake current(plug)	L, M, H	Maximum Plug braking current during direction switch change.
Plug turn current(plug)	L, M, H	Current at which braking ends and drive starts. (Fixed percentage only)
Neut. brake current(plug)	L, M, H	Maximum plug braking current in neutral.
Plugging threshold(plug)	L, M, H	Plug to drive threshold. Higher numbers mean earlier plug exit.
Plug drop current(plug)	L, M, H	Current at which neutral braking ends. (Fixed percentage only)
Footbrake current(plug)	L, M, H	Maximum plug braking current in neutral when F. brake switch active.
Dir. Brake current(reg)	L, M, H	Maximum regen braking current during direction switch change.
Neut. brake current(reg)	L, M, H	Maximum regen braking current in neutral.
Footbrake current(reg)	L, M, H	Maximum regen braking current in neutral when F. brake switch active.
Regen delay(reg)	L, M, H	Used to minimize delays for unsuccessful regen attempts at low speeds. Higher numbers give regen at lower speeds. 0 forces plugging only.
Maximum speed	L, M, H	Maximum allowable % on.
Outback speeds 1, 2 & 3	L, M, H	Maximum allowable % on when outback switches active.
Accel. delay 1, 2 & 3	L, M, H	Independently adjustable acceleration delays during speed outbacks.
Inch speed	L, M, H	Maximum allowable % on during inching operation.
Burst inch delay	L, M, H	Timer to allow inching for a set period only.
Bypass over current	M, H	Maximum allowable current in bypass before contactor opens.
Bypass delay	M, H	Time for bypass contactor to close after 100% on reached.
F.W pull in current	M, H	F. Weak, contactor allowed to pull in at current's pull in level.
F.W drop out current	M, H	F. Weak, contactor will drop out at current's drop out level.
Power steer delay	L, M, H	Delay after power steer trigger removed until contactor opens.
Seat switch delay	L, M, H, P	Delay after seat switch opens until outback is inhibited.
Zero level's	L, M, H, P	Used to select minimum voltage input level for function. E.g. an accel zero level of 0.5V means pulsing begins at 0.5V UP.
Full levels	L, M, H, P	Used to select maximum voltage input level for function. E.g. an accel full level of 4.0V means 100% pulsing is reached at 4V UP.
Speed limit	M, H	Used with external speed sensor to provide speed limit features.
Low voltage hit	L, M, H, P	Voltage at which controller starts reducing the max available current limit to help reduce voltage drops.
Low voltage outback	L, M, H, P	Voltage at which current limit is reduced to 0.
High voltage int	L, M, H, P	Voltage at which controller changes from regen braking to plug braking to help prevent high generated voltages damaging the battery or controller.

Adjustment	Logic type	Description (T=Affects tractor, P=Affects pump)
High voltage cutback	L, M, H, P	Voltage at which cutbacks will open, to prevent high voltage damage.
Battery protection	L, M, H, P	Voltages below this level cause a battery low / flesh fault.
Protection delay	L, M, H, P	Length of time the voltage can fall below the battery protection level for, before a fault is indicated. This helps prevent spikes tripping a low batt fault.
Pump speeds 1-7	P	Maximum allowable % on/a when respective switch active
Power steer speed	P	As above, but for power steer speed.
Pump comp. 1-4	P	Set-up compensation by adjusting the relevant pump speed to give the required minimum no load speed, then set the associated compensation adjustment to give the same speed under full load conditions
Power steer comp.	P	As above but for power steer speed compensation.
Power steer ramp up	P	Independent acceleration delay for power steer function.
Power steer ramp down	P	As above but for deceleration delay.
Speed 5, 6 & 7 Priority/additive	P	Lower numbers have priority over higher numbers. Additive is where the speed 5, 6 or 7 is added to lower numbered switches.
Trk:brk: brake delay	L, M, H	Used to specify a variable for a delay between the power steer trigger becoming inactive and the electric brake contactor opening (brake on).

8) DIAGNOSTICS

Traction and pump fault messages and LED status/number of flashes.







	Calibrator message	Standard display	Ful Feature display	LED	Description and how to clear	Check
0	OK (lowest priority)			0n	Traction operational and OK.	No action required.
1	Testing...	Run Tests		0n	Only displayed briefly at power up.	No action required.
2	RDI output	RDI Out	RDI OUT OUT	1F	RDI enabled and out-out action initiated.	Battery charges.
3	Thermal cutback	Over temp.	TRAC: HOT	3F	Traction heat sink above 75°C. Allow controller to cool.	Heat sinking, mounting, Sur faces clean, fan req.
4	Speed probe	Speed Probe	SPEED PROBE	4F	Speed limit feature enabled & wire off.	Probe connections.
5	Accel fault	Accel fault	ACCEL FAULT	5F	Accel. pedal pressed at power up, or wire off.	Accel wiring, Accel zero & Full Personalities.
6	Contactors out	Cont. o/c	CONTACT FAULT	4F	Contactors has bad contact or didn't close, motor o/c. Recycle FS1 & Dir.	Coil wiring, power wiring, motor o/c.
7	Contactors in	Cont. s/c	CONTACT FAULT	4F	Contactors didn't open or is welded. Recycle FS1 and direction switch.	Welder tips, particles in line wiring.
8	Sequence fault	Seq. Fault	SEQ FAULT	2F	Direction or FS1 switch at power up. Recycle direction FS1 or both.	Dir and FS1 in control and dir FS1 wiring.
9	2 Dir fault	2 Dir Fault	2 DIR FAULT	2F	Two directions selected together. Recycle both directions and FS1.	Direction switch wiring.
10	SFO fault	SFO Fault	SFO FAULT	2F	Dir. switch selected > 2 seconds after FS1. Recycle FS1 and Dir.	Dir. switch then FS1, FS1 and dir switch wiring.
11	Seat fault	Seat Fault	SEAT FAULT	3F	Drive selected and no seat sw. Recycle dir and FS1 switch.	Seat switch closed, seat wiring.
12	Inch Fault	Inch Fault	INCH FAULT	3F	Inch switch at power up, both inch switches selected or inching attempted with seat switch or Dir/FS1 selected. Recycle Inch switches.	Inch switch in neutral at power up, only 1 selected, Seat/Dir/FS1 switches open.
13	Battery low	Bat Low	BATTERY LOW	7F	Battery < Low battery personality. Recycle FS1 or direction switch.	Correct batt voltage, discharged battery.
14	Battery high	Bat High	BATTERY HIGH	7F	Battery > High battery personality. Recycle FS1 or direction switch.	Correct battery voltage. Loose or missing B+ to controller.
15	Pers error	Pers Error	PERS ERROR	1F	Personalities out of range at power up.	Reset personalities out of range (skewn BB...)
16	CRC error	CRC Error	CRC ERROR	1F	One or more personalities have been corrupted.	Check all personalities then recycle key switch.
17	Coil SAC	Coil SAC	COIL FAIL	8F	A contactor coil SAC or miswired. Recycle key switch.	Coil SAC, drive connected directly to B+ vs. wiring.
18	MOSFET SAC	FET SAC	MOSFET FAIL	3F	Bypass contactor SAC or MOSFET SAC. Recycle FS1 or Director.	W/PB power wiring. MOSFETs SAC.













(1) Diagnostic/status text messages









The controller can transmit text messages for diagnostic and status indication. On the standard display these appear over the status area, and on the full-feature display, they also overwrite the hours counter until the fault condition has cleared. This feature can be disabled via personality as described on the previous page. Some messages may be displayed with one or more symbols. The following table shows the fault message and symbols displayed for each fault condition.



B153EL263

No.	Message	Symbols displayed	Fault descriptor
0			Traction operational and OK.
1			Only displayed briefly at power up.
2	BDI OUT OUT		BDI enabled and cut-cut action initiated.
3	TRAC HOT	 & 	Traction heatsink above 75°C. Allow controller to cool.
4	PLWP HOT	 & 	Pump heatsink above 75°C. Allow controller to cool.
5	SPEED PROBE		Speed limit feature enabled & wire off.
6	ACCEL FAULT		Accelerator wire off. Recycle FSI and direction.
7	ACCEL FAULT		Accelerator pedal pressed at power up, or wire off. Recycle FSI and direction.

No.	Message	Symbols displayed	Fault description
8	CONTACT FAULT		Contactors has bad contact or didn't close. motor etc. Recycle FS1 & Dir.
9	CONTACT FAULT		Contactors didn't open or is welded. Recycle FS1 and direction switch.
10	SEQ FAULT		Direction of FS1 switch at power up. Recycle Direction, FS1 or both.
11	2 DIR FAULT		Two directions selected together. Recycle both directions and FS1.
12	SFO FAULT		Dir. switch selected > 2 seconds after FS1. Recycle FS1 and Dir.
13	SEAT FAULT		Drive selected and no seat sw. Recycle Dir and FS1 switch.
14	INCH FAULT		Inch switch at power up, both inch switches selected or inch/jog attempted with seat switch or Dir/FS1 selected. Recycle inch switches.
15	BATTERY LOW		Battery < Low battery personality. Recycle FS1 or Direction switch.
16	BATTERY HIGH		Battery > High battery personality. Recycle FS1 or direction switch.
17	PERS ERROR	 & 	Personalities out of range at power up.
18	CFG ERROR	 & 	One or more personalities have been corrupted.
19	COIL FAIL		A contactor coil S/C or miswired. Recycle keyswitch.

No.	Message	Symbols displayed	Fault description
20	MOSFET Fail	 & 	Bypass contactor S/C or MOSFET S/C Recycle HS: or traction.
21		 & 	Traction motor too hot.
22		 & 	Pump motor too hot.
23	FAIL	 & 	If any of those messages is displayed then the controller has failed one of its internal power up checks.

9) SERVICE AND FAULT LOGS(All logs)

The service and fault logs have been incorporated to allow end users and service personnel to inspect and note the controller's performance and fault history. Utilising the controller's existing status measurements and diagnostics capabilities, information (such as the maximum temperature the controller has operated at or the number and type of faults that have been detected) can be stored in non volatile memory and presented at a later date. Both the service and fault logs can be selected/deselected via the set-up menu on the calibrator, and when selected can be cleared at any time to start recording new data.

(1) Service log

Service information is available in the traction and pump status menus, where holding down the '+' key shows the maximum value of the current item, and holding down the '-' key shows the minimum value. The following items are logged:

- Maximum battery voltage
- Maximum motor current
- Maximum controller temperature and minimum controller temperature.

To clear the log, access the "service log - to reset log" message at the end of the status menu, and follow the prompts. The service log can be enabled in the setup menu.

(2) Fault log

The fault log is available at location 1.5 on the calibrator. Faults are grouped together by 'LED flash fault', the types of flash fault and whether each is logged is shown below.

Generally faults that can occur during normal operation e.g. a2 flash driver procedure error or an 8 flash thermal outback indication, are not logged.

- LED off faults Logged (Internal controller power up check faults)
- 1 flash faults Logged (Antenna/CRC faults)
- 2 flash faults Not Logged (Driver procedure/sequence/wiring type faults)
- 3 flash faults Logged (MOSFET/bypass wiring type faults)
- 4 flash faults Logged (Contactor O/C or S/C or wiring type faults)
- 5 flash faults Not Logged (Not used)

- 8 flash faults Not Logged;Potentiometer wire off type faults;
- 7 flash faults Logged(Battery low or High faults)
- 8 flash faults Not Logged;Thermal cutback faults)
- 3 flash faults Logged(Contactor coil S/C type faults)

Each of the above logged categories contains the total number of faults of this type, the key hours count of the most recent fault and a text description of the fault. An example of how the fault log information is presented is shown below :

This display shows that 12 4-flash faults have occurred and been logged, the most recent at

12*04F 12345.6hr Contactor o/c	12345.6 key hours and it was a contactor o/c fault.
-----------------------------------	---

Once into the fault log menu, the left and right arrows are used to view any faults stored and at the end of the list a "Fault list → to reset log" message is shown, where the fault log can be reset in a similar way to the service log. The fault log can be enabled and disabled in the setup menu.

10) CONTROLLER OPERATION AND FEATURE DESCRIPTIONS

(1) Traction operation

Applicable to all traction logics unless otherwise specified.

① Start up sequence

At keyswitch on, the direction and FS1 switches must be in the neutral condition simultaneously at least once before drive can be selected. This is a safety feature to help prevent unexpected movement immediately after power up.

② SRO(Static return to off)

This feature is optional in the setup menu and when specified, forces the following sequences of switch inputs to be followed before drive is allowed :

Keyswitch-Direction-FS1 or Keyswitch-FS1-Direction(within 2 seconds of FS1). Any other sequence will not allow drive. Drive will be inhibited if FS1 is active for more than 2 seconds with no direction selected. In this case the FS1 will need to be recycled.

③ Seat switch

If the seat switch is opened and the seat switch timer has timed out during drive the controller will stop pulsing and a seat fault will be indicated. Before drive can be restarted the seat switch must be closed, and FS1 and the direction switch must be recycled through neutral. Note the start sequence for drive requires that the seat switch is closed and both the direction and FS1 switches are in the neutral position simultaneously before drive can be initiated. The time period is programmed by means of the calibrator(seat switch delay). As a setup menu option the seat switch can also inhibit pump operation if required.

④ Handbrake switch(Not available on low %o logic)

An input is provided for the connection of a handbrake switch, which if operated will disable traction pulsing but leave the drive related contactors in position to effect a minimum roll back hill start when drive is selected and the handbrake is released.

⑤ Deceleration delay

This is an adjustable delay to ramp down the pulsing from 100% on to 0% on, and can be used to limit the inherent truck lurch when acceleration is interrupted. When neutral is selected, contactors are only opened when the % on has ramped down to 0.

⑥ Creep

The creep speed is adjustable and is used to select a minimum pulsing level as soon as drive is requested, to minimize delays and dead-bands. The motor voltage is rapidly ramped to the creep level (equivalent to a 100ms acceleration delay).

⑦ Cutback speeds

There are 2 cutback switch inputs as standard. An additional cutback 3 function can be configured in the setup menu. Each one has an associated personality to adjust the maximum % on when the switch is active. In addition, each cutback has an independently adjustable acceleration delay associated with it to further enhance low speed manoeuvrability. When both switches are active together, the lower speed is selected together with the slowest acceleration delay. The cutback speed inputs are usually normally closed so that a wire off type fault or bad connection initiates a lower speed.

When the BDI feature is enabled and the cut-out level is reached the speed 2 cutback is automatically initiated.

A maximum speed adjustment is also available to limit the maximum applied % on. (If the setting is less than 95% then bypass and field weakening are disabled).

⑧ Bypass (Not available on low I/O logic)

The bypass contactor is used to short out the main MOSFET switching device to increase speed and efficiency at high speeds and to allow higher motor currents than the controller's maximum current limit, to climb ramps laden or to escape from ruts or pot holes.

Bypass can be initiated in 2 ways:

Current-limit bypass: The accelerator is fully depressed and the controller has been in current limit for longer than 2 seconds. In order to prevent a sudden lurch of the truck the contactor will not be energised if the motor voltage during current limit is less than 20% of battery voltage. This mode of operation can be disabled via the setup menu.

High-speed bypass: If the accelerator is fully depressed and the controller has been pulsing at maximum % on for 1.5 seconds and the bypass delay personality has timed out. The bypass delay timer is a feature that can be used to allow the truck to obtain full speed, before contactor closure.

The bypass contactor will be de-energized if the accelerator demand is reduced below 86%, or if the motor current exceeds the bypass over-current dropout level, adjustable by the calibrator. To allow for initial overshoots the over-current test is disabled for the first 2 seconds of bypass. Although the software attempts to minimize arcing when the contactor opens, some arcing is inevitable under certain load conditions. After an over-current drop out, the bypass function will be inhibited until neutral is recycled to prevent repeated opening and closing of the bus under heavy current conditions. Bypass can be disabled by setting the over-current drop out to 0 A, also bypass will be disabled if either of the 2 speed cutback switches are enabled and the settings are adjusted below 95% or the maximum speed setting is less than 95%. Applying the footbrake switch or economy G% will also prevent bypass closure.

ⓐ Power steer, traction controller

A contactor drive is available to control a separate power steer motor. An adjustable delay allows the motor to operate for a set time, after the power steer trigger or power steer demand has been removed. SEVCON's standard trigger, i.e. when the contactor is closed, is when either FS1 or the footbrake switch is closed, or the traction unit is pulsing. It is an either/or situation, so any one of these 3 inputs is sufficient to trigger the power steer.

This standard trigger is designed to give power steer whenever the truck is moving, but not to have a situation where the power steer could be on continuously, i.e. on a direction switch where the truck could be left with a direction selected and the keyswitch left on. If FS1 or the footbrake is applied then the vehicle is either about to move or is moving, and the traction pulsing is used if the truck was neutral braking (pulsing) down a long ramp, it is conceivable that neither of the 2 switches would be closed. On a tow-tractor, power steer is disabled during latching.

An independent input pin also exists to trigger power steer operation. This is normally used in conjunction with a steer on demand system where an output is generated when the steering wheel is turned. This gives power steer on demand and is more efficient since typically no steering delay, or only a short delay is needed.

The independent trigger only, or other trigger combinations can be configured if necessary in the setup menu.

Some vehicles derive the power steering assistance from the main pump hydraulic motor, instead of having a separate steer motor. In this situation the trigger is fed to the pump controller and runs the pump at the speed set by the P. S. speed personality.

Independent ramp up and ramp down delays are provided when power steer assistance is derived from the main pump controller, to help tune steering responsiveness without affecting the main pump operation.

ⓑ Regen braking

Regen provides vehicle braking by controlling the motor as a generator and returning the generated energy back to the battery. Regen braking reduces motor heat dissipation compared with plug braking. Regenerative braking can be initiated in 3 ways, each with an independently adjustable braking level, as follows :

- a) A direction switch change will initiate regen braking at a level set by the direction brake current level. Braking effort is proportional to the accelerator position, with a minimum accelerator pedal position giving 50% of the set brake level increasing to 100% for a fully depressed pedal. The proportionality range allows the driver to modify the braking effort without allowing freewheeling. The proportionality feature is optional and can be configured in the setup menu to give fixed braking at the set personality level.
- b) Closure of the foot-brake switch in neutral, will initiate regen braking at the footbrake personality level. An input is provided to allow braking effort to be proportional to the footbrake position if a potentiometer is fitted. Setting a 0 into the personality disables braking on the footbrake switch.
- c) When neutral is selected, regen is initiated at the neutral brake current level. Setting a 0 into the personality disables neutral braking and allows freewheeling. Neutral braking will only be attempted if the % on in the previous direction exceeded 20% above the set creep level. This helps minimise unnecessary delays and contactor operations.

Regen braking is not possible at low speeds depending on the motor characteristics. To help minimize delays attempting to regen a regen time adjustment is offered which can be set so that regen is only attempted for a short period of time, which is sufficient to initiate regen at medium to high speeds but not to cause unnecessarily long delays at very slow speeds where regen is not possible. If the regen time setting is increased then regen can be initiated at lower speeds. Setting the regen time to 0 disables regen and forces plug braking only.

If regen is not possible due to low vehicle speed, the following action will be taken :

- For direction braking, plugging will be used to slow, then reverse the vehicle.
- For neutral or footbrake braking, the vehicle will freewheel.

The switching frequency in regen is high frequency and silent.

⑩ Plug braking

Plug braking is achieved by controlling the rotating motor armature as a generator and dissipating most of the energy in the motor and the plug diode.

For plugging-only controllers, the conditions for initiating braking are identical to those for regen controllers : On a direction change, footbrake switch and in neutral. Plugging also operates on regen controllers if the truck has been travelling so slowly to initiate regen direction braking.

The switching frequency in the plug braking mode is 6kHz.

⑪ Anti-rollback

This is a standard SEVOCON feature and is used to help prevent roll back conditions on ramps. If the driver reselects the previous direction after a neutral condition, braking is not attempted, and full drive power is available to restart on a hill.

⑫ Analogue inputs

The accelerator/analogue inputs are flexible in the range of signal sources they can accommodate and can be adjusted to minimize dead-bands and mechanical tolerances. Each analogue input has 2 adjustments associated with it, that allow the input voltage range to be determined.

For the traction accelerator, for example, the 2 adjustments are called the "Accelerator zero level" and the "Accelerator full level". If these were set to 0.20V and 4.80V then 0% pulsing would start at 0.20V at the input, increasing to 100% pulsing at 4.80V. For accelerators with decreasing voltage outputs, the zero adjustment might be set to 3.5V and the full adjustment to 0.0V.

The calibrator test menu shows the instantaneous voltage reading, and the equivalent % "push" for each input, and to allow easy set-up, pressing the "down" key on the calibrator from either of these test displays, allows a direct jump to the zero voltage and full voltage personality settings.

- ✖ Note that a 6 flash fault will occur if the full and zero levels are set within 0.50V of each other.

Ⓖ Traction accelerator

When drive is selected and the accelerator is first pressed, pulsing will commence at the creep speed setting increasing towards the maximum % on.

If the accelerator is depressed at power up, pulsing will be inhibited and a 6 flash fault will be indicated, until the pedal is released. In case of a wire off type fault, pulsing will be limited to the creep setting and a 6 flash fault will also be given.

Various accelerator characteristics i. e. relationship between accelerator push and the applied motor voltage, can be selected via the setup menu.

There are 4 options : Linear, curve, 2° slope and crawl. Set to linear for a straight line accelerator characteristic, curved for more low speed manoeuvrability, 2° slope for a balance between linear and curved, and crawl for a very shallow low speed manoeuvrability curve. See graph 2 for actual characteristics.

Ⓕ Footbrake switch

This input is available to allow a switch to be fitted to the footbrake pedal for constant braking. Note that footbrake operation drops out both bypass and field weakening.

Ⓖ Digital switch inputs

The digital inputs on the controller can be configured as active low inputs, where the switches are wired to 0-volts. Active high inputs, connecting to +ve, are not available. The SEVCON standard is active low, and is recommended for its low impedance input stage and immunity to moisture related problems.

A further configuration allows each input to be specified as normally open or normally closed.

Most switches are normally open, with the exception of the 2 speed cutback switch inputs which are normally closed, so that a wire off type fault, or bad connection initiates the cutback speed, other than a higher speed. On compensated pump systems the power steer input can be conveniently configured as normally closed.

Ⓖ Contactors

The pump logic has no contactor drives. The low I/O logic has 3 outputs for driving contactors, the medium I/O has 5 outputs and the high I/O has 10. On medium and high I/O logics it is also possible to reconfigure an output, as an external LED or lamp driver to allow dashboard indication of the controller's Integral LED.

The controller can diagnose open circuit (o/c) and short circuit (s/c) problems with certain contactors, as described in the diagnostic section. Generally, following a request to open a contactor the controller will report a 4 flash fault and a calibrator message if a successful operation was not detected after approximately 500ms. To help prevent against minor tip contaminants causing spurious diagnostic trips when closing a contactor, if a closure is not detected after 500ms, pulsing up to a maximum of 25% is allowed. This is designed to pass a controlled amount of current to try and break through any contaminant present to allow uninterrupted drive. If a closure isn't detected on reaching 25%, then the contactor drive is removed and a 4 flash fault is indicated.

An optional line contactor, not controlled from the controller, can be connected between the 6+ terminal of the controller and battery positive. A diode should be fitted in series with the line contactor coil to prevent large currents flowing through the battery connectors and into the internal capacitors when the controller is first connected to the battery. After the keyswitch has been switched, and once the capacitors have charged up (via internal resistance) the line contactor will be energised. An internal diode fitted in the keyswitch line will prevent any contactor energising if the polarity of the battery voltage is reversed.

On pump controllers the line contactor also gives a mechanical break. Under normal operating conditions contactors will operate without arcing. However, under certain fault conditions, contactors may arc when opening. The bypass contactor may also arc during bypass over current drop out conditions.

Ⓔ Contactor chopping

This feature allows 24V contactors to be used at all battery voltages 24V-80V, by continuously monitoring the battery voltage and chopping the contactor output pins accordingly, to present an average voltage suitable for 24V coils. Chopping is selectable by the calibrator. All the contactor drives will be either chopped or not chopped. It is not possible to select individual drives to chop. Care must be taken to ensure that chopping is always selected if 24V contactors are being used on battery voltages higher than 24V. In applications > 24 volts contactors must be fitted with blow out magnets.

Chopping can reduce the overall dissipation in the coils and allows only one set of contactors to be stacked for all battery voltages.

Chopping frequency approx. = 650Hz (Slightly audible at higher battery voltages).

Typical contactor coil voltage during chopping = 16 volts.

Typical contactor coil voltage during energisation = 24 volts for 1 second.

There are 3 contactor chopping options available via the setup menu: Off, On and 24V.

The off setting is used for nominal battery voltage coils, and the on setting is for 24V coils on higher voltage vehicles. Setting to 24V provides chopping for 24V coils and lamps without the drop the 16V after 1s.

Ⓕ Fail-safe

The controller's safety system includes a microprocessor watchdog which can detect software failure, and a hardware fail-safe system which can prevent dangerous runaway conditions in the event of certain hardware failures.

Every time the controller is powered-up, the software checks that the fail-safe circuit is able to switch off the MOSFETs and open the contactors.

Ⓖ Speed limit (Not available on low I/O logic)

A traction speed limit in KPH can be set via personality 1,1.33 (0 KPH disables the feature). As the speed of the vehicle approaches the limit, the maximum motor voltage is reduced. If the speed limit is exceeded by more than 2KPH (when the vehicle is travelling down-hill for example) electrical braking will be used until the speed of the vehicle falls to below the limit. Speed limit braking may operate in normal drive (as described above), to increase existing braking torque if the vehicle over-speeds, or if the vehicle is rolling in neutral.

The actual limit speed of the vehicle is typically \pm 2KPH of the personality setting, depending on motor loading. When the feature is enabled, a probe "wire-off" feature will limit the motor voltage if the probe is disconnected.

Calibration of the feature is made via the set menu items "full speed" (1.6.23) and "probe frequency" (1.6.24). Full speed should be set to the maximum speed of the vehicle, unloaded on level ground. The probe frequency setting should be the output frequency of the sensor at that speed.

The recommended sensor is an active low (i.e. NPN) inductive proximity switch. The output is connected to the customer connector, pin 9. A +12V supply on the customer connector pin 12 can be used for most types of sensor. The negative supply of the sensor should be connected to the controller's B- terminal. Contact SEVCON for further recommendations if required.

(2) Pump operation

① Pump Operation

There is no start-up sequence, so pulsing will be initiated after a small delay if power-up 1 or more of the pump switches is selected. There are adjustable ramp up and ramp down delays. A pump contactor can be specified as an option. There are facilities for prioritising pump speeds, for having different pump speeds added together and for having speed compensation for different load conditions.

② Pump speeds and Priorities

Each of the 5 pump switch inputs has its own speed setting. The pump speeds are prioritised in numerical order so that speed 1 has priority over all other speeds and speed 2 has priority over speeds 3 to 5, etc. Example: -If speed 1 is set to 10%, speed 2 to 20% and speed 3 to 30% then selecting speeds 1 and 3 will give 10% and selecting speeds 2 and 3 will give 20%.

③ Additive speeds

Pump switches 5 and 6 can be adjusted to have an "Additive" speed. In this mode, the switch is excluded from the priority system; instead its speed is added to the prioritised pump speed to give increased power required to handle simultaneous pump operations.

Example: -If speed 2 is set to 40%, speed 5 is set to 25% and speed 6 is set to 10%, then selecting all three switches will give a demand of 75%, and selection 2 and 6 alone will give a demand of 50%.

④ Pump accelerator Inputs

The pump accelerator demands are associated with speeds 1 & 2. The pump will operate at the creep speed setting when the accelerator is at minimum demand and change linearly to speed 1 or 2 as the accelerator is increased to the maximum demand. The pump pot accelerator input can be connected and adjusted as per the previously described traction accelerator input.

⑤ Power steer speed

On compensated pump systems this setting can be used to control the power steer speed from the main pump motor. This speed is selected from the power steer trigger input as previously described and can be compensated for as described in the section below. The power steer also has independent ramp up and ramp down delays. See the section 9.1.11 on power steer for more information.

⑥ Pump speed compensation

Some trucks utilise the main hydraulic pump motor to provide power steering assistance, instead of a separate power steer motor. This feature provides speed compensation so that the pump motor always provides steering assistance, whilst allowing the motor to slow down when assistance isn't required to minimise noise and improve efficiency. Pump speeds 1-4 and the power steer speed can be compensated if required.

The compensation is a straight line characteristic set up using 2 personalities. The set up procedure may require some repetition to give optimum performance of low load (low noise) and full compensated load. The low load speed is normally set up to run the pump motor at its lowest permissible lubrication speed to keep audible noise to an absolute minimum.

The calibrator's base speed sets up the low load speed and the compensation factor sets the amount of boost when the controller detects a current increase due to the pump motor load increasing. The controller monitors the motor current and changes the motor voltage to ensure that the motor remains on this compensated speed line.

Set up Procedure-Set both the base speed and the compensation factor to 0. Activate the pump switch associated with the speed to be compensated. Ensure that the motor has its minimum load. Increase the base speed until the correct operation speed at minimum load is achieved. Increase the load associated with this pump speed to its maximum. Increase the compensated speed until varying the load has little or no effect on the speed.

Example-Power steer compensation where the main pump motor provides the hydraulic steering assistance. Set the power steer personality base speed and compensation factor to 0. Activate the power steer trigger input and increase the power steer base speed until the pump motor is running at its desired low speed. Operate the steering. Very little assistance will be given if the pump is going slow. Increase the power steer compensation setting until the required amount of assistance is given when the steering is operated. The set-up is an iterative process so it may be necessary to change the base speed again and repeat the procedure to obtain optimum results.

(3) General operation

① Operating frequency

The drive frequency of both the traction and pump power frames is 16kHz, for silent operation. For traction regen-braking the frequency is also 16kHz, whilst plug braking is 6kHz.

② Temperature monitoring

If the temperature of either power frame exceed 75°C its maximum available current will be reduced. Note, however, that if the set current limit is less than the maximum available current limit actual cutback will occur at progressively higher temperatures than 75°C. The thermal cutback ensures that the maximum heatsink temperature is limited to 95°C.

When cutback occurs the diagnostic_LED will flash 8 times.

③ Safe operating area(SOA)

The controller's current may be limited at high and/or low duty cycles depending on its current and voltage specification. This is to reduce the thermal stress on the power components in order to increase long term reliability.

The "Safe Operating Area" is a characteristic of the MOSFETs and Freewheel Diode which make up the power-frame. The MOSFET SOA restricts current at high duty cycles on all configurations, and the Diode SOA tends to restrict the current at lower duty cycles on lower voltage applications.

For most applications SOA will have little or no effect on the operation of the controller. Its effect is more significant in protecting the controller against adverse loads such as damaged motors and static test rigs.

④ Under-voltage and over-voltage protection

In order to prevent a sudden loss in power, the controller will begin to linearly ramp down the current limit, once the average battery voltage falls below a pre-set under-voltage start level. The current will be ramped down to 0 and a 7 flash fault indicated if the averaged battery voltage falls below the under-voltage cutout level.

To protect the controller from over-voltage caused by prolonged regen braking will be terminated and plug braking initiated when the average battery voltage reaches the over-voltage start level.

If the voltage exceeds the over-voltage cutout level in braking then all contactors will open and freewheeling will occur, requiring the vehicle's mechanical brakes to be used.

Under any other circumstances if the battery voltage exceeds the over-voltage cutout level, all pulsing is stopped and a 7-flash fault is indicated. This protects against incorrect battery connection.

Nominal battery voltage	Under-voltage cutout	Under-voltage start	Over-voltage start	Over-voltage cutout
48V	29V	36V	65.0V	73.0V

⑤ Diagnostic LED

This is mounted between the connectors on the front of the controller. It serves as a simple diagnostic tool as explained below :

Constant illumination -No fault, normal condition

LED extinguished -Internal controller fault

1 flash -Personality out of range

2 flashes -Illegal start condition

3 flashes -MOSFET short Circuit

4 flashes -Contactor fault or Motor Open-Circuit

5 flashes -Not used

6 flashes -Accelerator or Speed Probe wire off fault

7 flashes -Low or High battery voltage or BDI cut-out operating

8 flashes -Over temperature

9 flashes -Contactor coil s/c

Further explanation of the LED flashes are displayed on the calibrator fault message section.

⑥ Fault Clearance

Any fault indication will be cleared by re-initiating the start sequence after the cause of the fault has been removed.

⑦ Software Version and Revision Indication

For identification purposes and to assist in queries, the Software version and revision, and the controller serial number are indicated in the calibrator test Menu.

⑧ Dashboard Displays

SEVCON's existing CAN based standard and full feature displays are compatible with Powernak controllers.

⑨ Setup Menu

A setup menu has been added to the calibrator that allows various features to be enabled and disabled. See 7) page 7-32 for more information.

Note. Once a change has been made to the setup menu, the key switch must be recycled for the change to be operational.

20. NEW MACHINE OILS

New machine uses following lubricants and oils.

Description	Specification
Gear oil	SAE 80W-90/API GL-5
Hydraulic oil	ISO VG46
Brake oil	DOT3
Grease	NLGI No 2

- API : American Petroleum Institute
- SAE : Society of Automotive Engineers
- ISO : International Organization for Standardization
- NLGI : National Lubricating Grease Institute

21. RECOMMENDED LUBRICANTS

Service point	Kind of fluid	Capacity (U.S. gal)			Ambient temperature °C(°F)						
		HF 20/25/30(C) 32-7	20BH-7 25BH-7 30BH-7	HF 15/18T-4	-20 (-1)	-10 (14)	0 (32)	10 (50)	20 (68)	30 (86)	40 (104)
Axle	Gear oil	5.9 (1.2)	—	0.35 (0.1)	SAE 80W/90/AGL5						
Hydraulic oil tank	Hydraulic oil	24 (5.4)	25.5 (5.8)	19.5 (4.4)	ISO VG32						
					ISO VG46						
					ISO VG68						
Brake system	Brake oil	0.5 (0.1)	—	—	DOT3						
Filling (Grease nipple)	Grease	0.1 (0.03)	—	0.1 (0.03)	NLGI No.1P						
					NLGI No.2						

8. SPECIFICATIONS

1. SPECIFICATION TABLE

1) HBF20/25-7

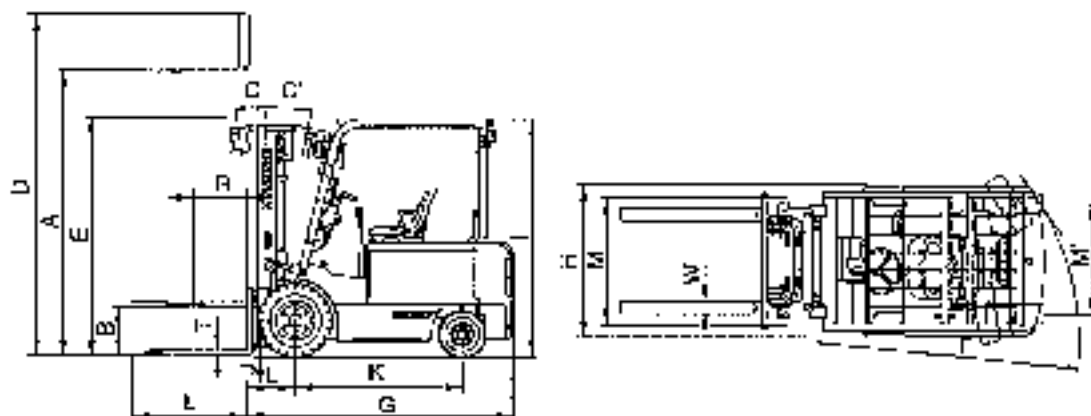

020721

Model		Unit	HBF 20-7	HBF 25-7
Capacity		kg	2000	2500
Load center		F mm	500	—
Weight(Unloaded)		kg	3965	4290
Fork	Lifting height	A mm	3300	•
	Free lift	B mm	155	—
	Lifting speed(Unload/Load)	m/1sec	530/370	530/360
	Lowering speed(Unload/Load)	m/1sec	450/500	•
Mast	L x W x T	L,W,T mm	1050 x 100 x 45	—
	Mast angle (forward/backward)	C/C' degree	6/10	—
	Max height	D mm	4165	—
	Min height	E mm	2175	•
Body	Travel speed(Unload/Load)		km/h	16.8/12.9
	Gradeability(Unload/Load)		degree	12.4/14.7
	Min turning radius(Outside)		F mm	1200
ETC	Max hydraulic pressure		kg/cm ²	180
	Hydraulic oil tank		l	24
Overall length		G mm	2267	2322
Overall width		H mm	1185	—
Overhead guard height		L mm	2220	—
Ground clearance		J mm	130	—
Wheel base		K mm	1420	—
Wheel tread front/rear		M, N' mm	990/880	—

2) HBF30/32-7

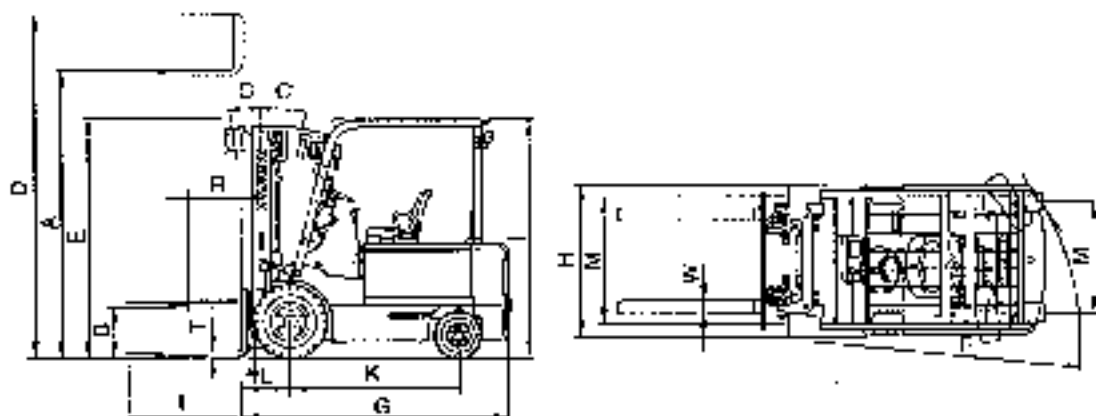

02028Pd

Model		Unit	HBF 30-7	HBF 32-7
Capacity		kg	3000	3200
Load center		R	500	—
Weight		kg	4715	4810
Fork	Lifting height	A	3300	3200
	Free lift	B	155	—
	Lifting speed(Unload/Load)		46/27/3	46/28/0
	Lowering speed(Unload/Load)		46/5/3	—
	L x W x T	L,W,T	1050 x 125 x 45	—
Maat	Tilt angle forward/backward	C/C'	8°/0	—
	Max height	D	4485	4385
	Min height	E	2190	—
Body	Travel speed(Unload/Load)		15.2/11.8	15.0/11.5
	Gradeability(Unload/Load)		10.8/11.1	10.5/10.8
	Min turning radius(Outside)	F	2235	2250
ETC	Max hydraulic pressure	kg/cm ²	180	—
	Hydraulic oil tank		24	—
Overall length		G	2507	2527
Overall width		H	1213	—
Overhead guard height		I	2250	—
Ground clearance		J	130	—
Wheel base		K	1580	—
Wheel tread front		M	890/980	—

3) HBF20/25/30C-7

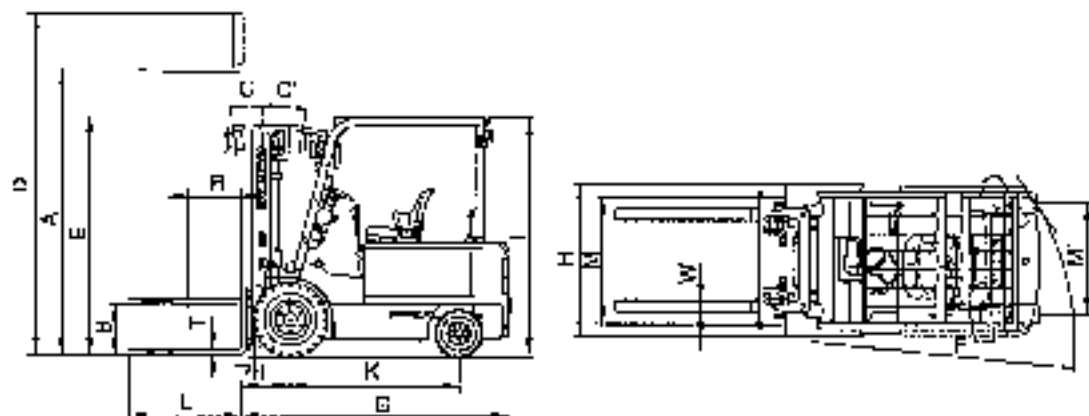

Draw3Pn

Model		Unit	HBF 20C-7	HBF 25C-7	HBF 30C-7	
Capacity		kg	2000	2500	3000	
Load center	R	mm	500	—	—	
Weight(Unloaded)		kg	2040	4280	4735	
Fork	Lifting height	A	mm	—	—	
	Free lift	R	mm	115	—	
	Lifting speed(Unload/Load)		mm/sec	530/370	580/360	460/270
	Lowering speed(Unload/Load)		mm/sec	450/500	—	480/510
L x W x I		L,W,I	mm	—	1370 x 125 x 45	
Tilt angle (forward/backward)		C/C'	degree	5/8	—	
Mast	Max height	D	mm	—	—	
	Min height	E	mm	—	—	
Travel speed(Unload/Load)			km/h	17.0/14.0	15.8/13.2	15.8/12.4
Gradeability(Unload/Load)			degree	12.2/11.0(13.3/11.0)	10.7/10.4(8.8/8.2)	9.1/10.2(8.9/8.2)
Min turning radius(Outside)		F	mm	1640	1835	2040
Max hydraulic pressure			kg/cm ²	180	—	—
Hydraulic oil tank			l	24	—	—
Overall length		G	mm	2108	2175	2307
Overall width		H	mm	1370	—	1512
Overhead guard height		I	mm	2235	—	—
Ground clearance		J	mm	90	—	—
Wheel base		K	mm	1290	—	1400
Wheel track front/rear		M, M'	mm	880/810	—	915/810

Fig. 36-V

4) HBF16/18T-5

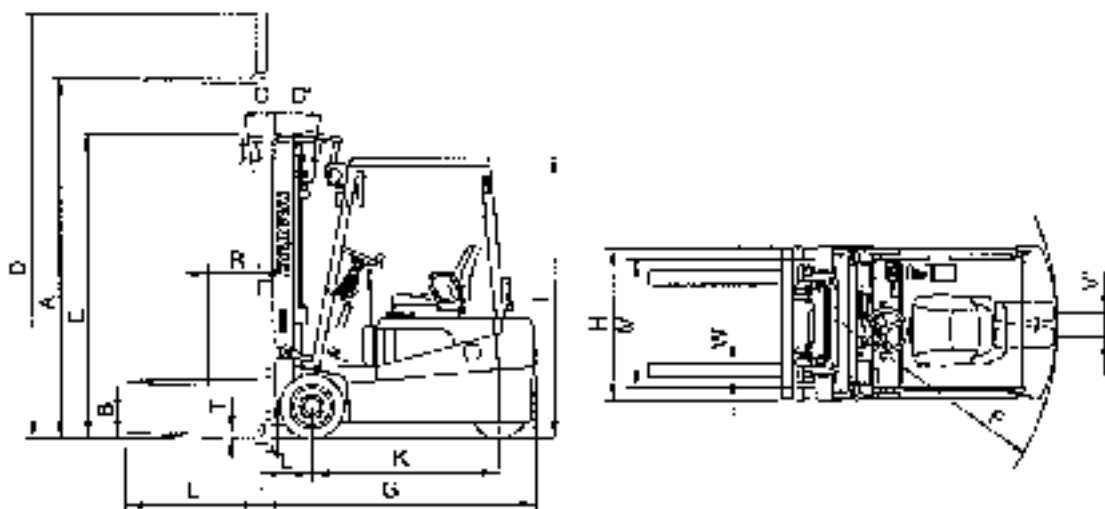

84102201

Model		Unit	HBF16T-5	HBF18T-5	
Capacity		q	1500	1750	
Load center	R	mm	500	-	
Weight		q	2915	3100	
Fork	Lifting height	A	mm	-	
	Free lift	B	mm	-	
	Lifting speed(Unload/Load)		mm/sec	420/330(3.75/2.9)	480/310(3.75/2.9)
	Lowering speed(Unload/Load)		mm/sec	450/500	-
	L x W x T	L, W, T	mm	1000 x 1000 x 40	-
Mast	Tilt angle forward/backward	°/°	57	-	
	Max height	D	mm	-	
	Min height	E	mm	-	
Body	Travel speed(In/Out)(km/h)		16.0/14.5(12.4/11.4)	15.8/14.2(12.3/11.2)	
	Gradeability(Unload/Load)		degree	11.8/3	10.0/8/7.6
	Min turning radius(Outside)	F	mm	1500	1550
E/C	Max hydraulic pressure		kg/cm ²	-	
	Hydraulic oil tank		l	19.5	-
	Electrolyte		l	132	132
Overall length	G	mm	1860	1910	
Overall width	H	mm	1070	-	
Overhead guard height	F	mm	1950	-	
Ground clearance(Mast)	J	mm	85	-	
Wheel base	K	mm	1250	-	
Wheel lead Iron/Pier	M	mm	905/205	-	

() : 96V

B) 20BH/25BH/30BH-7

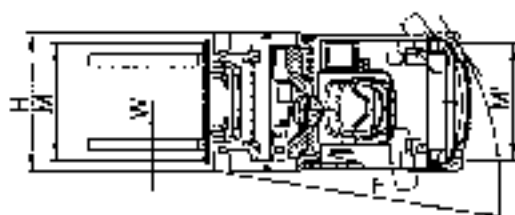
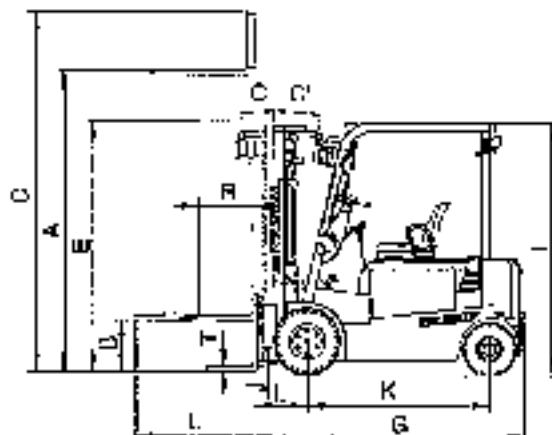

REG-03PH

Model		Unit	20BH-7	25BH-7	30BH-7	
Capacity		kg	2000	2500	3000	
Load center		F, mm	500	—	—	
Weight(Unloaded)		kg	4205	4405	5035	
Fork	Lifting height	A, mm	3300	—	—	
	Free lift	B, mm	115	—	—	
	Lifting speed(Unload/Load)		mm/sec	500/320	500/380	450/320
	Lowering speed(Unload/Load)		mm/sec	450/500	—	—
	L x W x T		L, W, T, mm	1050 x 100 x 45	—	1050 x 125 x 45
Mast	Tilt angle (forward/backward)	C/C', degree	6/8	—	—	
	Max height	D, mm	4405	—	—	
	Min height	E, mm	2150	—	2159	
Body	Travel speed(Unload/Load)		km/h	17.1/15.2	17.2/14.3	
	Steerability(Unload/Load)		degree	14.8/12.3	13.8/10.7	13.9/8.9
	Min turning radius(Unload)	F, mm	2070	2095	2129	
ETC	Max hydraulic pressure		kgf/cm ²	190	—	
	Hydraulic oil tank		l	25.5	—	
Overall length		G, mm	2339	2307	2540	
Overall width		H, mm	1195	—	1240	
Overhead guard height		I, mm	2150	—	2190	
Ground clearance		J, mm	135	—	114	
Wheel base		K, mm	1575	—	1719	
Wheel track(front/rear)		M, M', mm	600/980	—	1008/980	

2. SPECIFICATION FOR MAJOR COMPONENTS

1) HBF20/25/30/32-7

(1) MOTOR

Item	Unit	Drive motor	Hydraulic pump motor
Model	-	KIUF 4001	KKD9 4006
Type	-	LC Series, self ventilated	
Rated voltage	V	48	
Output:	KW	10.3	15.5
Brush size	mm	15 x 28 x 45	14 x 25.3
Insulation	-	Class F	

(2) BATTERY

Item	Unit	HBF 20-7(STD)	HBF 20-7(OPT) HBF 25-7(STD)	HBF 30/32-7 (STD)	HBF 30/32-7 (OPT)
Model	-	VCE 680	VCE 715	VCE 740	VCE 850
Rated voltage(option)	V	48(30)			
Capacity	AHr	650/5	715/5	740/5	850/5
Electrolyte	-	WET			
Dimension(W x D x H)	mm	1065 x 795 x 537		1095 x 890 x 537	
Connector(CE spec)	-	SB350(SB320)			
Weight(Max/Min)	kg	1300/1040	—	1500/1320	—

(3) CHARGER

Item	Unit	HBF 20/25-7	HBF 30/32-7
Type	-	Constant current, constant voltage	
Battery capacity for charge	V-Ah	48-600-900	48-845-850
AC input	V	Triple phase 400	
		Single phase 220	
		Triple phase 220/380	
		Triple phase 440	
DC output	V	52 ± 1	—
Charge time	hr	8 ± 2	—
Connector(CE spec)	-	SB 350(SBF320)	—

(4) GEAR PUMP

Item	Unit	Specification
Type	-	Fixed displacement gear pump
Capacity	cc/rev	29.0
Maximum operating pressure	bar	225
Rated speed(max/min)	rpm	9000/500

(5) MAIN CONTROL VALVE

Item	Unit	Specification
Type	-	3 spool, 4 spool
Operating method	-	Mechanical
Main relief valve pressure	bar	190

(6) DRIVE AXLE

Item	Unit	Specification	
Max input torque	kgf · m	24	
Max input rpm	rpm	3500	
Gear ratio	G2 : G1	-	44 : 17 (2.588 : 1)
	G3 : G2	-	49 : 22 (2.227 : 1)
	G4 : G3	-	50 : 13 (3.846 : 1)
	Total	-	22.172
Oil quantity	l	5.8	

(7) WHEELS

Item	Specification
Type(front/rear)	SOLID (OPT : Pneumatic, Non-marking)
Quantity(front/rear)	2/2
Front-drive	2/2.5 ton : 7.0J-12(12PR), 3/3.2 ton : 2B×6-15(12PR)
Rear-steering	10×7-8(16PR)

(8) BRAKES & STEERING

Item	Specification	
Brakes	Travel	Front wheel, duo servo & auto adjustment type
	Parking	Ratchet, internal expanding mechanical type
Steering	Type	Full hydraulic, power steering

2) HBF20/25/30C-7

(1) MOTOR

Item	Unit	Drive motor	Hydraulic pump motor
Model	-	KUCF 1001	KKCG 4005
Type	-	DC Series, self ventilated	
Rated voltage	V	48	
Output	kW	10.3	15.5
Brush size	mm	18 x 28 x 45	14 x 25.5
Insulation	-	Class H	

(2) BATTERY

Item	Unit	HBF20/25C-7	HBF 30C-7
Model(Type)	-	VC1 740(Lead acid)	VC1 845(Lead acid)
Rated voltage(option)	V	48(56)	
Capacity	Ah	740/5	845/5
Electrolyte	-	WET	
Dimension(W x D x H)	mm	1007 x 768 x 587	1007 x 866 x 587
Connector	-	SB350	
Weight(Max/Min)	kg	1400/130	1600/150

(3) CHARGER

Item	Unit	HBF 20/25C-7	HBF 30C-7
Type	-	Constant current, constant voltage	
Battery capacity for charge	V-Ah	48-680-800	48-845-850
AC input	V	Triple phase 410	
		Single phase 220	
		Triple phase 220/380	
		Triple phase 440	
DC output	V	82 ± 1	-
Charge time	hr	8 ± 2	-
Connector	-	SB 350	-

(4) GEAR PUMP

Item	Unit	Specification
Type	-	Fixed displacement gear pump
Capacity	l/min	29.0
Maximum operating pressure	bar	225
Rated speed(max/min)	rpm	3000/500

(5) MAIN CONTROL VALVE

Item	Unit	Specification
Type	-	3 spool, 4 port
Operating method	-	Mechanical
Main relief valve pressure	bar	190

(6) DRIVE AXLE

Item	Unit	Specification	
Max input torque	kg ² - m	24	
Max input rpm	rpm	3500	
Gear ratio	G2: G1	-	43:24 (1.792:1)
	G3: G2	-	49:22 (2.227:1)
	G1: G3	-	50:13 (3.846:1)
	Total	-	15.348
Oil quantity	l	6.3	

(7) WHEELS

Item	Specification
Type(front/rear)	CUSHION (Non-marking, L.G. Smooth)
Quantity(front/rear)	2/2
Front-drive	2,25 ton: 21×7×15, 3.0 ton: 21×8×15
Rear-steering	16×9-10.5

(8) BRAKES & STEERING

Item	Specification	
Brakes	Travel	Front wheel, cue-servo & auto adjustment type
	Parking	Ratchet, internal expanding mechanical type
Steering	Type	Full hydraulic, power steering

3) HBF15T/18T-5
(1) CONTROLLER

Item	Unit	D. motor controller	Hydraulic pump motor
Model		PP743	PP344P
Type		MOSEFET	←
Dimension	mm	142 × 142 × 135	←
Current limit	A	SEM 350A/50A	Series 450A
Communication	-	CAN	←

(2) MOTOR

Item	Unit	Drive motor	Hydraulic pump motor
Model	-	203-19-4001	KKDG 4006
Type	-	DC SEM, Self ventilated	DC SEM, Self ventilated
Rated voltage	V	48(3E)	48(3E)
Output	kW	5.5(4.5)	1.2(0.8)
Brush size	mm	-	14.5 × 25.3 × 38.0
Insulation	-	Class F	Class H

(3) BATTERY

Item	Unit	HBF15/18T-5	
Rated voltage	V	36V	48V
Dimension(W × L × H)	mm	990 × 545 × 835	
Min. Battery weight	kg	830	
Max. Battery weight	kg	1080	
Connector(CF spec)	-	SB 350 (SBE 320)	
Electrolyte	-	Refined dilute sulfuric acid	

(4) CHARGER

Item	Unit	HBF15T	HBF18T
Type	-	Constant current, constant voltage	
Battery capacity for charge	V-AH/hr	48V450-520/5	←
AC input	V	Triple phase 410	
		Single phase 220	
		Triple phase 220/380	
		Triple phase 410	
DC output	V	62 ± 1	←
Charge time	hr	8 ± 2	←
Connector		SB 350	←

(5) GEAR PUMP

Item	Unit	Specification
Type	-	Fixed displacement gear pump
Capacity	cm ³ /rev	22
Maximum operating pressure	bar	210
Rated speed:(max/min)	rpm	3000/500

(6) MAIN CONTROL VALVE

Item	Unit	Specification
Type	-	3 spool, 4 spool
Operating method	-	Mechanical
Main relief valve pressure	bar	135

(7) DRIVE UNIT

Item	Unit	Specification
Max drive output	W	4.5
Max wheel load	kg/b	2500/5512
Acceleration at the wheel	kgf - m/kl - t	1320/974
Braking moment at the wheel	kgf - m/kl - t	1700/1254
T/M ratio	-	22
Weight without fluid	kg/b	26.5/62.2
Oil quantity	l/US - qt	0.35/0.37

(8) WHEELS

Item	Specification
Type(front/rear)	SC10(Cushion, Lug, Smooth, Non-marking)
Quantity(front/rear)	2/2
Front-drive	18 x 7-8(18 x 7 x 12.125)
Rear steering	16 x 6-8(16 x 6 x 10.5)

(9) BRAKES & STEERING

Item	Specification	
Brakes	Travel	Front wheel, wet disc brake
	Parking	Roller type
Steering	Type	Full hydraulic, power steering
	Steering angle	60° to both right and left angle, respectively

4) 20BH/25BH/30BH-7

(1) MOTOR

Item	Unit	Drive motor	Hydraulic pump motor
Model	-	KUOL 4001	KADP 4001
Type	-	DC Series, salt ventilated	
Rated voltage	V	60	
Output	kW	15.5	18.0
Brush size	mm	18 × 28 × 45	19 × 40 × 45
Insulation	-	Class H	

(2) BATTERY

Item	Unit	20BH/25BH-7	30BH-7
Model (type)	-	VCJ 5	VCJ 8
Rated voltage	V	60	
Capacity	Ah	50Ah	60Ah
Electrolyte	-	WET	
Dimension (W × D × H)	mm	1025 × 708 × 764	1076 × 852 × 764
Connector	-	SBE320(BLACK)	
Weight (Max/Min)	kg	1705/1470	2065/1790

(3) CHARGER

Item	Unit	Specification
Type	-	Constant current, constant voltage
Battery capacity for charge	V Ah	30500-600
AC Input	V	Triple phase 410
		Triple phase 220/380
		Triple phase 440
DC output	V	101 ± 1
Charge time	hr	8 ± 2
Connector	-	SBE320(BLACK)

(4) GEAR PUMP

Item	Unit	20BH/25BH-7	30BH-7
Type		Fixed displacement gear out-p	
Capacity	cm ³ /rev	29.0	29.0
Maximum operating pressure	bar	250	
Rated speed(max:min)	rpm	3000/500	

(5) MAIN CONTROL VALVE

Item	Unit	20BH/25BH-7	30BH-7
Type	-	3 spool, 4 spool	
Operating method	-	Mechanical	
Main relief valve pressure	bar	190	210

(6) DRIVE AXLE

Item	Unit	Specification
Max input torque	kg ² ·m	24
Max input rpm	rpm	3500
Gear ratio	G2: G1	14 : 17 (2.588 : 1)
	G3: G2	49 : 22 (2.227 : 1)
	G4: G3	50 : 13 (3.846 : 1)
	Total	22.172
Oil quantity	l	5.3

(7) WHEELS

Item	20BH/25BH-7	30BH-7
Type(front/rear)	SOLID (OPT : NON-MARKING)	
Quantity(front/cor)	2/2	
Front-drive	23 x 9-10	23 x 10-12
Rear-steering	18 x 7-8	

(8) BRAKES & STEERING

Item	Specification	
Brakes	Travel	Front wheel, duo-servo & auto adjustment type
	Parking	Patches, Internal expanding mechanical type
Steering	Type	Ful hydraulic, power steering

3. TIGHTENING TORQUE

1) HBF20/25/30/32-7

NO	Items		Size	kgf·m	N·t
1	Electric system	Hyd pump motor mounting bolt	M10×1.5	6.9±1.4	50±10
2		Drive motor mounting bolt	M10×1.5	4.8±0.5	34.7±3.6
		Steering motor mounting bolt	M10×1.5	6.9±1.4	50±10
3	Hydraulic system	Hydraulic pump mounting bolt	M10×1.5	5±1.0	36.5±7.2
4		MCV mounting bolt, nut	M8×1.25	2.5±0.5	18.1±3.6
5		Steering unit mounting bolt	M8×1.25	2.5±0.5	18.1±3.6
7		Brake cylinder mounting bolt	M10×1.5	6.9±1.4	50±10
9	Power train system	Drive axle mounting bolt, nut	M20×2.5	50.5±2.5	365.3±18.1
10		Steering axle mounting bolt, nut	M20×2.5	58±3.0	419.5±21.7
11		Front wheel mounting nut	M18×1.5	23.5±1.5	170±10.8
12		Rear wheel mounting nut	M14×1.5	17.5±1.5	128.6±10.8
13	ETC	Counterweight mounting bolt	M24×3.0	100±15	723±106
14		Seat mounting nut	M8×1.25	2.5±0.5	18.1±3.6
15		Head guard mounting bolt	M12×1.75	19±3.0	137.4±21.7

2) HBF20/25/30C-7

NO	Items		Size	kgf·m	N·t
1	Electric system	Hyd pump motor mounting bolt	M10×1.5	6.9±1.4	50±10
2		Drive motor mounting bolt	M10×1.5	4.8±0.5	34.7±3.6
		Steering motor mounting bolt	M10×1.5	6.9±1.4	50±10
3	Hydraulic system	Hydraulic pump mounting bolt	M10×1.5	5±1.0	36.5±7.2
4		MCV mounting bolt, nut	M8×1.25	2.5±0.5	18.1±3.6
5		Steering unit mounting bolt	M10×1.5	6.9±1.4	50±10
7		Brake cylinder mounting bolt	M10×1.5	6.9±1.4	50±10
9	Power train system	Drive axle mounting bolt, nut	M20×2.5	50.5±2.5	365.3±18.1
10		Steering axle mounting bolt, nut	M20×2.5	58±3.0	419.5±21.7
11		Front wheel mounting nut	M18×1.5	23.5±1.5	170±10.8
12		Rear wheel mounting nut	M14×1.5	17.5±1.5	128.6±10.8
13	ETC	Counterweight mounting bolt	M24×3.0	80±10	578±72
14		Seat mounting nut	M8×1.25	2.5±0.5	18.1±3.6
15		Head guard mounting bolt	M12×1.75	19±3.0	137.4±21.7

3) HBF15T/18T-5

NO	Items		Size	kg - m	lul - ll
1	Electric system	Hyd pump motor mounting bolt	M10×1.5	0.9±1.4	50=10
2		Drive motor mounting bolt	M14×2.0	15.2±3.0	140=22
3	Hydraulic system	Hydraulic pump mounting bolt	M10×1.5	5±1	38=7.2
4		MCV mounting bolt, nut	M 8×1.25	2.5±0.5	18.1=3.6
5		Steering unit mounting bolt	M 8×1.25	2.5±0.5	50=10
6		Brake cylinder mounting bolt	M 8×1.25	2.5±0.5	18.1±3.6
7		Hydraulic oil tank mounting bolt	M 8×1.25	2.5±0.5	18.1±3.6
8	Power train system	Drive axle mounting bolt, nut	M14×2.0	13.8±1.2	98.8=18.7
9		Steering axle mounting bolt, nut	M14×2.0	16±2.0	115.7=14.5
10		Front wheel mounting nut	M14×1.5	14±1.5	101=10.8
11		Rear wheel mounting nut	M14×1.5	14±1.5	101=10.8
12	ETC	Counterweight mounting bolt	M30×3.0	50	382
13		Seat mounting bolt	M 8×1.25	2.5±0.5	18.1=3.6
14		Head guard mounting bolt	M12×1.75	12.8±3.0	93=22

4) 20BH/26BH/30BH-7

NO	Items		Size	kg - m	lul - ll
1	Electric system	Hyd pump motor mounting bolt	M10×1.5	6.8±1.4	50=10
2		Drive motor mounting bolt	M10×1.5	4.8±0.5	34.7=3.6
		Steering motor mounting bolt	M10×1.5	6.9±1.4	50=10
3	Hydraulic system	Hydraulic pump mounting bolt	M10×1.5	5±1.0	38.5=7.2
4		MCV mounting bolt, nut	M 8×1.25	2.5±0.5	18.1=3.6
5		Steering unit mounting bolt	M10×1.5	6.8±1.4	50=10
7		Brake cylinder mounting bolt	M10×1.5	6.9±1.4	50=10
9	Power train system	Drive axle mounting bolt, nut	M20×2.5	58.5±2.5	385.2=18.1
10		Steering axle mounting bolt, nut	M20×2.5	58±3.0	418.5=21.7
11		Front wheel mounting nut	M18×1.5	36±2.0	260=14.5
12		Rear wheel mounting nut	M14×1.5	23±1.0	166=7.2
13	ETC	Counterweight mounting bolt	M24×3.0	80±10	578=72
14		Seat mounting nut	M 8×1.25	2.5±0.5	18.1=3.6
15		Head guard mounting bolt	M12×1.75	18±3.0	137.4=21.7

 **HYUNDAI**
HEAVY INDUSTRIES CO., LTD.

PART NO. 591F11-30040
Printed in Korea (05 12, 210)