



Model SLT30/35 AC Operator's Manual



Table of Contents

1 Forklift Safety and Familiarity

Operator Training & Safety	1-2
Site Supervision	1-2
Terminology and Illustrations Used	1-3
Understanding Safety Statements	1-3
SLT30 AC Decals and Placement	1-4
Decal Definitions	1-4
Operator Safety	1-7
Seat Belt	1-8
Seat Safety Switch	1-9
Parking Brake	1-9
Tipping Hazards	1-9
Longitudinal Tipping Can Occur When:	1-9
Lateral Tipping Can Occur When:	1-10
Longitudinal or Lateral Tipping Can Occur:	1-10
Traveling and Load Handling	1-10
Speed	1-11
Visibility	1-12
Battery Safety	1-12
Service/Repair Safety	1-13

2 Receiving/Inspecting/Towing/Shipping

Items Furnished With Your Truck	2-1
Items Required	2-1
Tools and Test Equipment	2-1
Preparing the Truck	2-1
Inspecting the Truck	2-2
Storage, Towing or Shipping	2-3
Truck Storage	2-3
Towing the Truck	2-3
To Ship the Truck	2-4

3 Understanding SLT30AC Truck

Vehicle Description	3-1
Truck Identification	3-2
Identification Plate	3-3
SLT30 AC Serial Number Code	3-4
Knowing the Rated Capacity	3-5
Truck Overview	3-5
Frame	3-5
Brake System	3-5
Safety Interlock	3-5
Electrical System	3-6
Hydraulic System	3-7
Mast Controls	3-8
Mast Lift	3-8
Mast Tilt	3-8
Mast Side Shift	3-8
Mast Pivot	3-8
Mast Assemblies	3-8
Driver Controls	3-11
Foot Pedals	3-11
Steering Wheel and Tilt Clamp	3-11
Driver's Seat	3-12
key switch	3-13
Dash Display	3-13
Joystick	3-14
Principles of Forklift Operation	3-15
Understanding Stability	3-15
Basic Principles	3-15
Load Center	3-17
Counterweight	3-17
Maximum Fork Lift Height	3-18
Tilting Considerations	3-18
Attachments	3-18
Determining the Load Weight	3-18
Workplace Conditions	3-19
Working in Hazardous Environments	3-20

4 Operating the SLT30 AC Truck

Getting On and Off the Forklift	4-1
Controls and Indicators	4-1
Driver's Seat	4-1
Joystick Operation	4-2
Lift and Tilt Operation	4-2
Pivot and Side Shift Operation	4-2
Wire Guidance Button	4-3
Auxiliary Hydraulic Function	4-3
Direction Control Switch	4-3
Horn	4-3
Steering Wheel and Tilt Clamp	4-4
key switch	4-4
Dash Display	4-4
Accelerator Pedal	4-6
Brakes	4-6
Brake Pedal	4-6
Parking Brake	4-6
Basic Operating Procedures	4-7
Driving Position	4-7
Starting and Traveling	4-8
Turning and Intersections	4-8
Stopping	4-9
Parking	4-9
Handling a Load	4-10
Setting the Forks	4-11
Retrieving a Load	4-12
Forklift Tipping	4-15
Turning	4-15
Transporting a Load	4-16
Traveling on Inclines	4-16
Unloading Your Forklift	4-17
Dockboards and Trucks	4-20
Warning Devices	4-21
Fire Extinguisher Option	4-21

Optional Systems Operation	4-21
Landguide Wire Guidance System	4-21
Wire Guidance Operation	4-21
Fork Positioner Option	4-22

5 Operator's Daily Checklist

Inspections Overview	5-1
Maintenance Schedule	5-1
Daily Checklist	5-3
Tires and Wheels	5-5
Static Discharge Strap(s)	5-6
Battery	5-7
Parking Brake	5-11
Service Brakes	5-11
Accelerator Control	5-11
Lift Chains	5-11
Forks	5-12
Electrical Fastener Connections	5-12
Hydraulic Cylinders, Fittings and Hoses	5-12
Hydraulic Oil	5-12
Operator Controls	5-12
Lights and Alarm	5-15
Steering	5-16
Steer Column Tilt & Telescope	5-16
Dash Display/ Verify Gauges	5-16
Seat, Belt, Slides & Switch	5-16
Major Structural Points	5-17
Safety Labels	5-17
Capacity Plate	5-17
Unusual Noises	5-17
Recommended Lubricants	5-18
Technical Specifications	5-20

Forklift Safety and Familiarity

This section of the SLT30 AC Operator's Manual will address important operator level safety information regarding the operation and maintenance of your SLT30 AC Forklift.

IMPORTANT

The SLT30 AC Model trucks have been designed for optimum safety of their operators. Please follow the safety guidelines listed and adhere to all Caution, Warning, and Danger notes found within this manual.



WARNING

When the truck is in operation, always keep loose clothing, jewelry, hair and fingers out of the restricted pinch areas as labeled on the truck.

This chapter on Safety must be carefully read, understood and adhered to strictly by all operators and service personnel operating the SLT30 AC Model Forklift.

DO NOT use this truck until you have thoroughly read this manual. Failure to comply could cause risk of death or serious injury to yourself and others

* Landoll and SLT30 AC are trademarks of the Landoll Corporation. All other brand and product names are the trademarks of their respective holders.

Landoll forklifts meet or exceed ASME B56.1 - Part III, Safety for Powered Industrial Trucks and are FRMC approved by meeting or exceeding requirements of FRMC Class 7820, ANSI/UL-583 standard for Battery Powered Industrial Trucks, Types E, ES, and EE.

The electrical systems complies with UL-583 requirements for type E, ES (optional), and EE (optional) Electrical Battery-Powered, Industrial Truck construction.

Operator Training & Safety



DANGER

Every forklift operator must be trained in accordance to the rules provided by appropriate legislation.



DANGER

Your employer must ensure that each powered industrial truck operator is competent to operate a powered industrial truck safely, as demonstrated by the successful completion of the relevant training course. Operating a powered industrial truck without the proper training can cause serious injury or death.



WARNING

DO NOT make modifications or additions to electrical devices. DO NOT tamper with, remove or disconnect safety features or modify protective guards (such as overhead guards or load backrest extensions).

Any of the above could affect truck capacity and/or safe truck operation and is a serious safety violation that could cause personal injury and/or weaken the overall truck construction.

NO Modifications or Additions may be made to this truck without prior written permission from Landoll Corp.

Site Supervision

Supervision is an essential element in the safe operation of powered industrial lift trucks. The site supervisor must check that the Operator's Manual is in the seat compartment of the truck at all times. Operators must be trained on the use, maintenance and safety aspects of the SLT30 AC Model trucks under the supervision of a trained and experienced operator. Only those individuals trained to operate and/or maintain this truck may do so. Familiarization and driving practice with a new truck must be arranged in a safe area, away from other trucks, obstacles and people. The training program must be applied to all new operators, regardless of previous experience. Operator performance must be evaluated to ensure they have the proper skills and knowledge to operate the truck. Operators must be retrained when new equipment is introduced, existing equipment is modified, operating conditions change or an operator's performance is determined unsatisfactory.

FORKLIFT SAFETY AND FAMILIARITY

The truck must be inspected daily for problems or damage risking the safety of the driver and anyone in the work area, or possibly damaging the truck and/or the load being moved. When trucks are used on a round-the-clock basis, they must be inspected after each shift. Problems found must be reported and corrected. The truck must be taken out of operation until all repairs have been made and the truck has been re-inspected for safety.

Terminology and Illustrations Used

Whenever front and rear, right and left are mentioned throughout this manual, it is assumed that you are standing behind the vehicle looking toward the forks.

This manual references many illustrations to follow the procedures and help you locate components on your SLT30 AC forklift.

You will note that each illustration has an identifying Figure number below.

Understanding Safety Statements

You will find various types of safety information on the following pages and on the product decals attached to the vehicle. This section explains their meaning.

The Safety Alert Symbol means YOUR SAFETY IS INVOLVED!

 DANGER
Proceed with extreme caution. Failure to heed notice will cause injury/death to person and/or damage product.

 WARNING
Proceed with caution. Failure to heed warning will cause injury to person or damage product.

 CAUTION
Proceed with caution. Failure to heed caution may cause injury to person or damage product.

NOTE

You must read and understand the information in this manual and on the product decals before you attempt to operate or maintain this vehicle.

SLT30 AC Decals and Placement

The location and type of each product decal on the SLT30 AC forklift is illustrated on page 1-5 and page 1-6. Keep your forklift decals legible. Replace damaged decals

Decal Definitions

1. Safety Information
2. *Blank*
3. American Flag
4. Identification Plate
5. Battery Warning
6. Area Clear Caution
7. OverHead Guard Complies
8. Tire(s) Warning
9. Overall Warning Statements
10. Hydraulic Fluid Only
11. *Blank*
12. No Riders Warning
13. Pinch Point Caution
14. SwingMast Logo
15. Landoll Logo
16. Landoll Logo
17. SLT30AC Decal
18. *Blank*
19. Joystick Control Functionality
20. Emergency Battery Disconnect
21. Battery Connector Enclosed
22. www.landoll.com
23. Persons Injury danger
24. ES - FRMC Requirements
25. EE - FRMC Requirements
26. Landoll / Drexel Logo
27. Don't Remove Overhead Guard

FORKLIFT SAFETY AND FAMILIARITY



Figure 1-1: Right Side Decal Placement

FORKLIFT SAFETY AND FAMILIARITY



Figure 1-2: Left Side Decal Placement

Operator Safety



WARNING

- Check that all directional controls and the joystick are in their “NEUTRAL” position and your seat belt is fastened before setting the key switch to “ON”. See “Seat Belt” on page 1-8.
- To avoid personal injury, when operating the truck, be extremely cautious that NO part of your body (feet, arms, legs, fingers, clothes) are outside the operator’s compartment. Serious injury by obstacles, aisle supports or other trucks may occur.
- Know the location of all pinch points, as indicated by the WARNING and DANGER labels on the truck.
- Be cautious when there are other people or fixed objects in the working area.
- Be cautious when the load reduces visibility, see “Visibility” on page 1-12.



WARNING

- Ensure that people stand clear of the rear swing area before making turns.
 - NEVER lift, lower or transport people.
 - NEVER allow anyone on or under the forks (or load). NEVER allow riders anywhere on the truck, other than the operator.
 - When driving in narrow aisles, make sure there is enough space for the truck and the load, travel at reduced speeds, and where applicable, request a helper to guide you safely through the area.
-
- *The operator is responsible for observing all instructions and safety regulations in their daily work routine.*
 - *Be careful at cross aisles, doorways and other locations where people may step into the path of travel of the truck.*
 - *Check the condition of the truck at the start of each work shift. In particular, check the operation of the steering and brakes, the direction control lever, tilt and lift/lower, the condition of the battery, parking brake, horn, and signaling devices.*

FORKLIFT SAFETY AND FAMILIARITY

- *Make sure all access/service panels, doors and covers are installed, closed and latched tight. DO NOT operate the truck with panels, doors and covers removed, opened or unlatched.*
- *Keep the truck clean and in good working order. Report any problems or damage risking the safety of the driver or any people in the work area. Problems found must be reported and corrected. The truck must be taken out of operation until all repairs have been made and the truck has been reinspected for safety.*
- *Always start, stop, change direction, travel and brake smoothly so as not to shift the load and/or overturn the truck.*
- *DO NOT indulge in stunt driving or horseplay.*
- *Drive carefully and slowly onto dock boards and bridge plates. DO NOT exceed the rated capacity of the dock boards or bridge plates and ensure dock boards or bridge plates are properly secured with anchors or with devices that will prevent slipping.*
- *Check that dock boards have substantial contact with both the dock and the carrier, preventing them from rocking or sliding.*
- *Maintain a safe distance from the edge of ramps, platforms and other similar working surfaces.*
- *When leaving the operator's compartment, the forks must be lowered to the floor, the mast must be placed in a vertical position, all controls must be in a "NEUTRAL" position and the key switch must be set to the "OFF." Truck wheels must be blocked if the truck is parked on an incline.*

NOTE

A powered industrial truck is considered unattended when the operator is 25 feet (7.6 m) or more away from the truck.

Seat Belt

The driver's seat belt must always be worn. The lap part of the belt must be worn low & snug on the hips, just touching the thighs, without twist.



WARNING

A twisted belt can seriously injure you. In a crash or a tip-over, the full width of the belt would not be available to take up the impact forces.

IMPORTANT

Make sure the release button on the buckle is positioned so you can unbuckle the seat belt quickly in case of an emergency.

FORKLIFT SAFETY AND FAMILIARITY

Seat Safety Switch

A seat switch tells the vehicle controllers when a driver is in the operator's seat. Traction operations will shut down if the seat switch opens, signaling that a driver is not in the operator's seat.

Note: A two to three second delay is programmed into the seat switch to avoid nuisance shutdown and interruption of normal operations.

Parking Brake

The parking brake is automatically set when required. No hand operated park brake is present.

Tipping Hazards



WARNING

- Lift truck tip-over can cause serious injury or death to the operator or others in the area. Every operator must be thoroughly familiar with the tipping hazards listed in this section and avoid any operation of the truck which is likely to result in tipping.
- All lift trucks are subject to the risk of tipping over when accelerating or when applying the brakes abruptly.
- Transporting loads off-center also increases the risk of tip-over.

If a tip-over occurs, the operator should follow these guidelines:

- **DO NOT jump.**
- **Brace your feet firmly.**
- **Hold on tight.**
- **Lean away from the tip.**

The operator must use good judgment based on proper training, the operating surface (or road) conditions and experience to determine turning radius and speed for the load being handled.

A truck can tip longitudinally (tipping over the front wheels) or laterally (tipping either to the left or right side).

IMPORTANT

Tipping over in these conditions is made more likely by overloading, excessive mast tilt, or off-center positioning of the load.

Longitudinal Tipping Can Occur When:

- the truck is overloaded.
- the mast is tilted forward excessively, with or without a load.
- the load is raised and brakes or the accelerator are applied while the truck traveling.
- the truck is driven forward down a steep incline with a load.

FORKLIFT SAFETY AND FAMILIARITY

Lateral Tipping Can Occur When:

- the truck is turned sharply while traveling rapidly in either direction, with or without a load. An unloaded truck can tip easier than a loaded truck (with the load lowered).
- the load is raised and the truck is being turned while traveling in either direction.
- the load is raised and the truck is being turned and accelerated or braked while traveling forward or backward.
- the truck is turned while traveling on a ramp or other inclined surface.
- a load heavier than the rated truck capacity is lifted.

Longitudinal or Lateral Tipping Can Occur:

- When driving over objects, off the edge of a paved surface or driving over a pothole.
- Be cautious not to drive off the edge of a loading dock or off the edge of a loading ramp.
- If the truck collides with another vehicle or if the mast runs into an overhead obstruction.
- When loading or unloading a DOT truck or trailer, make sure the highway truck cannot move away from a dock while loading is in process. Make sure the highway truck or trailer has its brakes applied, key switch turned "OFF" and if on an incline, has the wheels blocked.

- Soft tires also reduce stability. The truck is equipped with tires of a size and hardness that will provide the necessary traction and maintain a proper shape to minimize tipping. Always replace tires with the type originally supplied by Landoll Corp.

Traveling and Load Handling

- Observe all traffic regulations. Keep to the right and maintain a safe distance from the truck ahead based on speed of travel. Keep the truck under control at all times.
- Yield the right of way to other people in the area.
- Slow down and sound the horn at cross aisles and other locations where visibility is obstructed.
- Keep a clear view of the path of travel and be alert for other traffic and people.
- Under all travel conditions, operate the truck at a speed that allows you to bring the truck to a complete stop safely.
- DO NOT handle unstable loads. Use care when tilting forward or backward, stacking, depositing, or retrieving a load. NEVER travel with the mast tilted forward.

FORKLIFT SAFETY AND FAMILIARITY

- NEVER exceed the truck's maximum lifting capacity. Refer to "Technical Specifications" on page 5-20 and the identification plate located to the left side of the operator. **See Figure 1-1.**
- The Identification plate lists the load weights allowable for various fork heights, battery information and also lists the truck model number, serial number and other truck data.
- Pay particular attention when picking up a load, to ensure the load weight and height requirements are within the truck's capacity. Truck stability and handling may be adversely affected.
- DO NOT transport loads or other people and items within the operator's compartment or other areas of the truck.
- Check that the load is properly positioned on the forks before lifting.
- Spread forks as far apart as the load permits and push completely under the load. Check that forks and loads are centered. Use care when handling off-center loads.
- Travel with forks straight ahead, and the mast tilted backward.
- Travel with forks or load in recommended traveling position.
- Elevate mast or load only to pick up or deposit a load. Watch out for obstructions, especially overhead. Watch all clearances.
- Tilt a loaded mast slowly.
- DO NOT release the lift/tilt control suddenly when handling loads. This may cause bouncing of the carriage, which could dump the load.
- DO NOT allow anyone, under any circumstances, to walk or stand under the forks or any part of the load.
- NEVER place any part of your body between the mast structures or any moving part of the truck.
- DO NOT turn when traveling on ramps. When descending ramps, travel forward (forks facing downhill) when empty. Travel backward (forks facing uphill) when carrying a load.
- Use care when traveling without a load. Avoid high speeds, sharp turns and abrupt stops.

Speed

Travel speed to be chosen according to the load handled, road surface conditions, visibility, people working in the area, moving and fixed objects in the area and/or cross aisles.

Operate the truck at a speed that will allow you to stop safely.



WARNING

Careless driving, such as fast starts or abrupt braking, excessive speed at turns or through cross aisles, sudden stops and hard turns at high speeds can all lead to serious personal injury and damage to the truck and load. Always drive with safety as your number one goal.

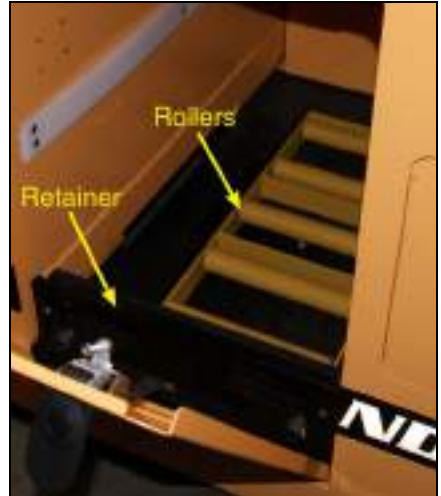

Figure 1-3: Battery Rollout Tray

Visibility

Where visibility is restricted, travel at very slow speed and use the horn frequently.

Always ask for a helper to guide you safely through an area where visibility is restricted.

Always rotate in the driver's seat to face in the forward direction.



Figure 1-4: Battery with Retainer

Battery Safety

The SLT30 AC Model truck is standard with a rollout battery tray, See Figures 1-3 and 1-4.

The battery restraint must be inserted and securely locked in place whenever the battery is installed. A rollout safety switch will not allow the truck to move unless the restraint is in place.

The truck battery contains concentrated sulfuric acid which can cause severe chemical burns. When the battery is charging, it releases hydrogen gas, a colorless, odorless and highly explosive gas which can be ignited by a spark.

FORKLIFT SAFETY AND FAMILIARITY

- Eliminate all sparks or flames from the charging area. Shorting battery terminals can release enormous amounts of energy, causing sparks or flames and/or heating nearby components to dangerous temperatures.
- The battery is very heavy and if restraints are not replaced after maintenance, the battery could slide out of the truck, causing electrical shorts, spill acid, or it could cause the truck to tip over.
- The battery is also used as a counterweight. A different size or weight battery could cause the truck to become unstable and tip. Use a battery that meets the weight and size specifications shown on the capacity plate on the operator's compartment. **See Figure 1-1.**

Service/Repair Safety

When it becomes necessary to do any service repair or maintenance to the truck, it is important to first review the following safety guidelines:

1. Be sure to replace the proper nuts, bolts and other fasteners, with the identical original type. It is recommended to use only Landoll authorized replacement parts.
2. Whenever possible, return the truck to a service area with sufficient lighting, work space and an assortment of tools needed to complete the service.
3. Set the key switch to "OFF" and set the direction control lever to "NEUTRAL."
4. Disconnect the battery and perform a "LockOut/TagOut" procedure.
5. NEVER place a tool or any metal object on top of the battery where it could possibly touch battery terminals causing a short or serious electrical shock.
6. Make sure all lifting devices and supports, such as a jack or support stand are capable of handling the weight of the load being applied.

 WARNING
You could be injured or the truck could be damaged if you try to do service work without proper training and equipment, or correct replacement parts.

 WARNING
To be certain the truck will not move, place wedges (or blocks of wood) at the front and back of the tires.

FORKLIFT SAFETY AND FAMILIARITY

7. Always place an appropriate support stand under the truck if it is being lifted, then lower the truck to the stand, having both the lifting device and stand supporting the weight of the truck.



DANGER

Going under a truck when it is lifted or jacked is extremely dangerous and could cause serious injury or death.

NEVER go under a truck that is supported only by a jack.

8. Fully open the required truck covers and be sure they are braced to prevent accidental closing.

Receiving/Inspecting/Towing/Shipping

This section of your SLT30 AC Forklift Operator's Manual provides you the information you will need to successfully receive the truck and prepare it for operation.

Before shipping from the Landoll Corporation, each SLT30 AC Model truck is inspected to make sure the truck you receive is in impeccable condition and compliments your order.

We do recommend that you:

- Inspect the truck for any signs of physical damage during shipment. Note any apparent damage on the bill of lading and request the delivery agent sign it. Report the damage to your distributor and the shipping company.
- Verify that the truck configuration and options match your purchase order. Report any discrepancies to your distributor.

Items Furnished With Your Truck

Standard SLT30 AC Model trucks are shipped from the factory with one copy each of the SLT30 AC Operator's Manual, including an "Operator's Daily Checklist" (starting on page 5-3), an SLT30 AC Parts Manual, a battery disconnect handle and a set of keys attached to the truck.

Items Required

When the truck is received, a battery approved for use in the truck must be installed. The battery must be replenished from a battery charger at certain intervals. No additional items are required to operate the truck.

Tools and Test Equipment

In general, no special tools or test equipment beyond those found in a well-equipped service center are required for general maintenance. However, custom bearing and seal installation tools and calibrated torque wrenches are helpful when performing more involved service.

Preparing the Truck

1. Check the hydraulic oil level, see "Hydraulic Oil Level" on page 5-11.
2. Check the fluid level in the brake master cylinder reservoir.
3. Check the condition of the battery, see "Charging a Wet Cell Battery" on page 5-8.

Inspecting the Truck

IMPORTANT

Upon receiving the SLT30 AC forklift, use the “Operator’s Daily Checklist” starting on page 5-3 to verify and monitor that your forklift is in proper working order.

Before releasing the truck for use, prepare a log book or log sheet for each truck at your site. List all services, repairs and adjustments performed over time, as well as equipment or operational problems and when they are recorded and repaired, along with hour meter reading and date the service was performed. Permanent logs serve as a checklist to show maintenance and repair history.

With the truck key switch set to “OFF” and the direction control switch set to “NEUTRAL”, perform a walk-around inspection. Always pay strict attention to all CAUTION, WARNING, and DANGER decals affixed to the truck and thoroughly read the Safety Chapter 1 of this manual. Check for obvious damage that would require more detailed inspection. If you notice or suspect a problem immediately report it to your supervisor, record it in the truck log book and have it checked and/or repaired before operating the truck.

Many problems can be spotted by visual inspection of the truck including oil leaks, damaged tires, cracks in welds or forks, damaged covers, etc.

Dirt, grease, oil and debris can mask some problems. If possible, the truck should be washed on a regular basis. To remove stubborn grease buildup, a grease-dissolving solvent may be needed. Make sure the solvent is not harmful to painted surfaces.

After spot cleaning, lubricate all unprotected grease fittings and metal-to-metal surfaces located outside the truck. See Table 5-1 on page 5-17 for Lubrication information. For truck lubrication points, **See Figure 5-4**. Refer to “Lubrication Areas” on page 5-18.



DANGER

Grease solvents are often toxic and may be flammable. Use only in accordance with the solvent manufacturer’s recommendations supplied with the solvent.

Use only in a well-ventilated area and DO NOT breathe vapors.

Wear protective goggles, aprons and gloves. Avoid contact with skin, eyes and clothes.

Keep away from heat and flame. DO NOT smoke when using solvents or in the area where solvents are stored.

Failure to observe these precautions may result in death or injury.

Storage, Towing or Shipping

Truck Storage

For long-term storage, the truck battery should be removed and stored where it can be periodically checked and recharged every three months. In general, batteries that are fully charged with the electrolyte at the proper level may be stored for up to one year. Batteries should be stored in a cool, dry, well-ventilated area, covered with a non-conductive material to protect them from dirt, moisture, etc.

IMPORTANT

DO NOT drape flexible plastic sheeting over batteries as it might trap explosive gases underneath. For batteries stored for more than one year consult the manufacturer.

Consult the battery documentation or the manufacturer for storage method and routine inspection required during the temporary storage interval.

The truck should be stored indoors within a temperature range of +35° F (2° C) to +115° F (46° C). Areas of high humidity should be avoided when possible. The truck should be raised with the tires at least 2" (51 mm) off the floor and the frame set on large wooden blocks. Hard polyurethane tires over long periods of time can develop flat spots that may not return to normal when the truck is returned to service, rendering the tires defective.

If the truck must be stored outside, it must be covered securely with a tarpaulin. Continued exposure to sunlight will cause deterioration of rubber tires, as well as gaskets and hoses, etc.

Towing the Truck



WARNING

- **Make sure the towing equipment is capable of handling the weight of the truck being towed.**
- **NEVER lift a truck using straps, chains or hoists of any type.**
- **NEVER connect lifting equipment to the operator's compartment overhead guards.**
- **NEVER tow a truck that is carrying a load.**
- **NEVER connect towing equipment to the mast.**

If the truck breaks down and cannot be repaired at that location, it may be towed by attaching a suitable hook and chain to the towing slots in the left and right rear quarter panels of the truck. **See Figure 2-1.** Also, with no power to the truck, the park brake will be engaged and the steering system will not operate. To release the park brake for towing, unplug it from the truck harness, and insert the park brake plug into the harness receptacle labeled "Tow Plug". **See Figure 2-2.** When the key switch is turned "ON", this plug will release the park brake while

RECEIVING/INSPECTING/TOWING/SHIPPING

disabling operation of the truck, thus allowing you to tow the truck to a service location. If you are not able to power up the truck, a manual release is also located on the park brake. To manually release the park brake, push down on the handle attached to the park brake and hold down. Once you have the park brake released, either through the tow plug or manually, carefully and slowly tow the truck backwards to your service repair area. An operator must be on the towed truck, wearing a seat belt.



Figure 2-1 Tow Slots



Figure 2-2 Tow Plug

To Ship the Truck

1. Set the mast to its forward position (straight ahead).
2. Back the truck onto its carrier so that the forks are pointed away from the forward direction of motion.
3. Set the mast to its forward (level) position and lower the forks to the bottom of the mast – align the mast indicator pointer located on the left side of the mast, as viewed from the front of the truck.
4. Set wedges against the front and rear tires and fasten them to the floor of the carrier. If the carrier is equipped with rings or receptacles for chains or cable rope, support the truck as firmly as possible.

IMPORTANT

DO NOT run chain or wire over the battery cover or any other finished metal surface. Use padding as necessary to protect the truck finish from chains or cables.

Understanding SLT30AC Truck

This section of your SLT30 AC Forklift Operator's Manual contains information that will familiarize you with the basic design and operating principles of your SLT30 AC forklift.

Vehicle Description

The SLT30 AC is a very narrow aisle type lift truck. The principle lifting capability is accomplished by the weight of the load, which is carried on the forks in front of the drive wheels, being offset by the combined weight of the heavy truck chassis and its battery.

The SLT30 AC forklift is available in a 3,000 and 3,500 lb. capacity. The mast can be pivoted 90° to the right as well as side shifted. This permits the vehicle to act as a conventional, as well as a narrow aisle sideloader forklift.

The SLT30 AC Model truck also includes:

- A three-wheel configuration with dual front wheel, single rear wheel steering and drive.
- Joystick operation for load functions, utilizing one joystick for mast operations (raise/lower, tilt, pivot, and sideshift). A fifth (5th) function hydraulic valve is available for an approved Class II attachment.
- 48-volt lead-acid battery that provides power for the electric system, the lights, and other auxiliary equipment.
- Triplex or quadplex high visibility mast configurations.
- Lift capacity 3,000 lbs./1,363 Kg. at 24"/600mm load center for SLT30 AC and 3,500 lbs./1,588 kg at 24"/600mm load center for SLT35 AC.
- Ergonomically designed operator compartment that includes sit-down operator position, adjustable driver's seat, tilt/telescoping steering wheel, hand operated joystick with direction control switch, horn, wire guidance switch and auxiliary hydraulic function switch with an armrest.
- Safety interlocks with key switch activation and operator seat safety switch. Also an electrical return to neutral lockout requires the direction control switch to be in the neutral or center position before drive can be restored.
- Automatic spring applied electric release parking brake.
- Machine model, serial and option numbers (where applicable) are stamped on the capacity nameplate affixed to the right of the operator's compartment. **See Figure 3-2.**

UNDERSTANDING SLT30AC TRUCK

Truck Identification

The following illustration will help you locate components on your SLT30 AC forklift. See Figure 3-1.

1. Forks
2. Load Backrest
3. Mast
4. Load Wheels
5. Steer/Drive Wheel
6. Overhead Guard
7. Rear View Mirror
8. Key switch
9. Emergency Interrupt Switch
10. Dash Display
11. Battery Compartment
12. Steering Column
13. Identification Plate
14. Frame ID Number Location
15. Mast ID Number Location



Figure 3-1: Truck Components

UNDERSTANDING SLT30AC TRUCK



Figure 3-2: Identification Plate

Identification Plate

The identification plate, which lists the rated capacity, serial number and other vehicle characteristics is in the right of the operator's compartment. **See Figure 3-2.**

The following list explains each item that appears on the identification plate

- Model - Model number of your SLT30 AC forklift.
- Serial No. - Serial number of your SLT30 AC forklift.
- Mast No. - Serial number of the mast appears here.

- Rated capacity - The rated capacity is stated with the forks at various fork heights. As you lift the load higher, the rated capacity of the forklift decreases.
- Lift height - This is the fork height stated in inches and centimeters. This is the distance between the ground and the top edge of the forks.
- Weight - The rated capacity of the forklift at various fork heights. Rated capacity stated in pounds and kilograms.
- Unladen Mass Without Battery - The actual weight of your SLT30 AC forklift as built without the battery installed; stated in pounds and kilograms.
- Minimum Service Weight of Battery - The battery must weigh at least this much for your SLT30 AC forklift to operate properly; stated in pounds and kilograms.
- Maximum Service Weight of Battery - The battery must not exceed the weight stated here for your SLT30 AC forklift to operate properly; stated in pounds and kilograms.
- Maximum Unladen Mass - This is the Unladen Mass Without Battery added to the Maximum Service Weight of Battery; stated in pounds and kilograms.

UNDERSTANDING SLT30AC TRUCK

- **Battery Type** - This is the rating for the battery itself as designated by Underwriter's Laboratory (UL) Standard 583. This describes the construction of the battery and enclosure with respect to the risk of fire, electric shock and explosion.
- **Truck Type** - This designation assigned by the Underwriter's Laboratory (UL) Standard 583 describes the overall design of the electrical components on the truck. Type "E" offers safeguards against an inherent risk of fire and electrical shock. Types "ES and EE" add additional safeguards to prevent emission of hazardous sparks and limits surface temperatures.
- **Nominal Voltage** - Nominal voltage indicates that the truck uses a 48 VDC battery.
- **Horizontal Load Center** - The horizontal load center is equal to one-half the length of the rated load when the weight is evenly distributed.
- **Vertical Load Center** - The vertical load center is equal to one-half the height of the rated load when the weight is evenly distributed.

SLT30 AC Serial Number Code

The following information will help decode the SLT30 AC serial number.

SLT30 AC aa-ww-ymms-xxxxx:

aa	30 for 2000lb. rated capacity 35 for 3000lb. rated capacity
ww	46 for 46" frame width
y	last digit of year of manufacture (ex. "9" = 2009)
mm	month of manufacture
s	component series; i.e. "D"
xxxxx	frame number



CAUTION

- **The frame number is located on the left side of the frame. See Figure 3-1. Compare the frame number listed on the identification plate with the number on the frame of the truck before you operate the truck.**
- **The mast serial number is also located on the left side of the mast. See Figure 3-1. Compare the mast serial number listed on the identification plate with the number on the mast before you operate the truck.**

Knowing the Rated Capacity



DANGER

NEVER load the truck beyond its rated capacity. Loads beyond the rated capacity can cause axles to break, the truck to tip over or loads to fall, causing serious injury or death. See identification plate for rated capacity and load center information. See Figure 3-2.

Truck Overview

Before operating your SLT30 AC Forklift, it is imperative that you familiarize yourself with the basic components of the truck. The following sections describe the different components that make up your SLT30 AC Forklift.

One of the most important facts you need to know about your SLT30 AC forklift is its rated capacity (how much weight it can safely lift). This weight is listed as the rated capacity on the capacity plate. The rated capacity varies for each load depending on:

- Where the horizontal and vertical load centers are.
- The height you plan to lift the load.
- Attachments used.

Frame

The frame is constructed from multiple steel parts welded together to form the basic structure of the truck and provide adequate counterbalance to offset the weight of the load. The frame is machined after it is welded to keep tolerances tight and ensure proper fit of assembled components.

Brake System

The front load wheels are equipped with hydraulically-actuated drum brakes. The brake pedal activates a master cylinder to apply hydraulic pressure to brake shoes, forcing the shoes to contact the spinning drum. The system is a dedicated system using standard DOT 3 brake fluid.

Safety Interlock

Both a key switch and an operator's seat switch must be activated before the truck can move. The seat switch is activated when the operator is seated in the driver's seat, see "Seat Safety Switch" on page 1-9 for additional information.

UNDERSTANDING SLT30AC TRUCK

Electrical System

The electrical control system is controlled by a vehicle master controller which in turn controls two A.C. motor controllers (pump and traction), a steering controller, a dash display and an optional wire guidance unit. Also included in the electrical system are a joystick, solenoid contactors, safety interlocks, three A.C. motors, a torque feedback device, a proportional control valve, power cables, fuses and electrical harnesses.

The following paragraphs provide more detail about the various components that make up the electrical system:

Vehicle Master Controller

The vehicle master controller is the main control unit for the truck. It controls inputs from and outputs to the three A.C. Motor controllers as well as a wire guidance unit, joystick, Torque Feedback Device and the dash display.

Traction

The traction system is comprised of an A.C. drive motor with a maximum rating of 525 amps. It is controlled by a single A.C. motor controller that is ultimately controlled by the vehicle master controller (VMC). A sensor inside the motor calculates actual motor speed and provides feedback to the controller for precise smooth operation. SLT30 AC Model trucks are three wheeled trucks where the rear wheel both drives and steers the truck. The A.C. drive motor is coupled to a helical bevel drive unit to power the truck.

Main Pump Motor (Lift)

The A.C. lift motor has a maximum rating of 525 amps and is controlled by its own A.C. motor controller (identical to the traction controller), which is ultimately controlled by the VMC. Just like on the traction motor, a sensor inside the pump motor allows for the calculation of actual motor speed providing feedback to the control system. Motor speed and acceleration during lift, tilt, side-shift and pivot functions are independently programmable. A non-contact hall effect sensor within the joystick senses the joysticks position and controls the motor speed. Operating temperature and amp draw of the motor are reduced affording longer run times per shift. The maximum speed of the motor for each function is programmable, thus reducing hydraulic fluid heat and power consumption. SLT30 AC controllers provide more smooth and precise function speed control.

UNDERSTANDING SLT30AC TRUCK

Battery

A 48 volt lead-acid battery provides drive power, as well as power for the hydraulic system, lights and other auxiliary equipment.

For maintenance and/or emergencies a big red power interrupt button is provided on the right-hand side of the driver's compartment.

Battery Rollout Tray

For maintenance, a rollout battery tray allows for easy battery removal from the right side of the truck. **See Figures 1-3 and 1-4.** The rollout battery tray assembly includes:

- Rollout tray
- Battery retainer weldment
- Battery rollout switch

Emergency Interrupt

The emergency interrupt is located on the right side of the seat. **See Figure 3-1.** Activate the emergency interrupt by pushing the red button down to disconnect all power from the truck. The truck will come to an abrupt stop because the park brake will engage. To reset pull button up. Use this button:

- in case of fire, smoke or overheating.
- if a person comes between the truck and an object.
- in case an accident occurs.
- in case of a short circuit or other electrical malfunction. Example: Pump motor is on continuously.

Steering

The steering system is a steer-by-wire system that consists of a small electric A.C. motor that turns a ring gear coupled to the drive unit. A torque feedback device coupled to the steering wheel provides input and feedback to the steering controller via an encoder to control the steer motor. The torque feedback device also provides a torque on the steering wheel that simulates the feel of the conventional hydraulic steering systems.

Optional Wire Guidance System

The wire guidance system, controlled by the VMC, is comprised of 2 antennas (front and rear) as well as a wire guidance controller. When the wire guidance system is activated, the wire guidance controller uses feedback provided by the two antennas to control the vehicles steering, speed and direction.

Hydraulic System

The lift hydraulic system is powered by an A.C. electric motor connected to a vane pump. This system provides primary and secondary circuit power for the mast tilt (forward and backward) and side shift (right-to-left) via two cylinders; pivot (in and out) via a single double-acting cylinder; and mast lift/lower (up and down) positioning.

UNDERSTANDING SLT30AC TRUCK

System cooling uses convection and conduction of heat from the reservoir, hydraulic tubing and cylinders to maintain a safe operating temperature below 175° F (97.22° C). Filtering consists of a steel mesh suction filter within the hydraulic reservoir, plus an easily accessible return line filter (10 micron rating).

The following points detail how each of the hydraulic functions operate:

Mast Controls

Mast positioning is achieved by operating the proportional control valve via a non-contact hall effect in the joystick. Hydraulic pressure is provided by a vane pump driven by a single A.C. electric motor. Mast movements may be operated individually or together, however, when operated together, the speed of operation is somewhat slower. A fifth (5th) function hydraulic valve is available for an approved Class II optional attachment.

Mast Lift

The mast lift circuit provides the means for lifting and lowering the mast and fork assembly. The mast lift consists of three hydraulic cylinders - one primary and two secondary, a velocity fuse and a flow regulator.

Mast Tilt

The mast tilt circuit provides the means for moving the mast and fork assembly forward and back. Tilting movements are accomplished through the use of two hydraulic double-acting cylinders mounted to the bottom of the pivot arm.

Mast Side Shift

The side shift circuit provides the means for moving the mast laterally (left-to-right). Side shift movements are accomplished using two hydraulic cylinders that push the crosshead, mounted on nylatron slides.

Mast Pivot

The mast pivot circuit provides the means for moving the mast assembly from the forward position to a 90° right facing fork position. Pivot movements are accomplished by the use of the pivot cylinder mounted between the pivot arm and crosshead assemblies.

Mast Assemblies

Various mast assembly configurations (triplex or quad) can be applied to the SLT30 AC Model trucks to provide both collapsed and extended heights suitable for all customer requirements. The lifting capacity of the mast also varies depending on the truck and its application. Load capacities are

UNDERSTANDING SLT30AC TRUCK

determined at 24" (609.6 mm) centers, centered on the mast and include all attachments on the carriage. The SLT30 AC specifications list the dimensions of standard masts available for these trucks. See "Technical Specifications" on page 5-20.

Also check the identification plate in the operator's compartment for the maximum lifting capabilities based on the particular truck and mast combination. See **Figure 3-2**.

The trucks are counterweighted to compensate for all positions of the maximum allowed load.

Masts are engineered to distribute thrust loads evenly between the rollers and rails. Masts move as a unit, providing maximum strength and endurance for the rated load and consist of up to four pairs of channels or rails (steel beams) rolling one within the other on steel rollers. The outer rails provide guidance and support for the middle rails, which in turn guide and support the inner rails. The truck forks are mounted on a carriage assembly that runs on rollers within the inner rails. See **Figure 3-3**. On a triplex mast, a primary cylinder is supported by the inner rails and hydraulically controlled. As the primary cylinder rod extends, a sheave and chain assembly lift the fork/carriage upward at twice the distance covered by the cylinder rod. This first stage of carriage lift is called free lift. It is the distance of lift available without increasing the overall height of the mast assembly. See **Figure 3-4**.

A secondary cylinder, attached to the outer rails, lifts the middle and inner rails progressively via chains, rollers and sheaves. The inner rails are raised at twice the rate of extension of the secondary cylinder piston. This upward lift continues until the secondary cylinders are fully extended. See **Figure 3-5**.

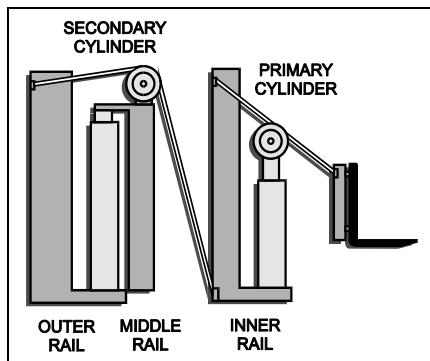

Figure 3-3: Mast - Collapsed

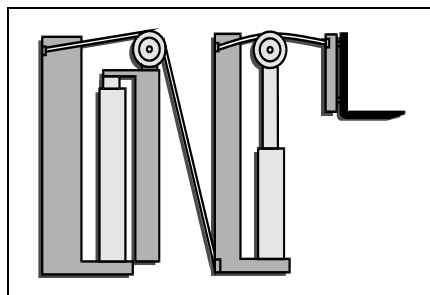

Figure 3-4: Mast - Free Lift

UNDERSTANDING SLT30AC TRUCK

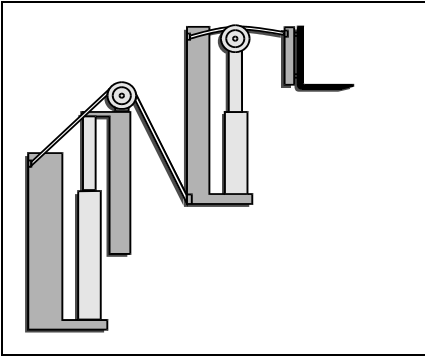

Figure 3-5: Mast Fully Extended

The hydraulic fluid used to lift the primary cylinder is applied sequentially to the secondary cylinder. When the primary cylinder reaches full extension, the secondary cylinder begins to extend. The differences in weights being supported by the cylinders, along with the differences in cylinder diameters, ensure that the primary cylinder will be fully extended before the secondary cylinder can begin to move. Consequently, when the mast is raised, it moves through two phases:

- Free lift, in which only the carriage assembly moves, up to the maximum height allowed by the inner rail. **See Figure 3-4.**
- Rail extension, in which both the middle and inner rail moves, carrying the carriage upward.

See Figure 3-5.

Downward movement of the mast is accomplished by releasing the hydraulic fluid from the cylinders back into the reservoir.

The weight of the rails and carriage provides enough pressure to force the fluid from the cylinders. When the secondary cylinder piston is fully contracted, the primary cylinder begins to collapse, forcing its fluid back to the reservoir.

The mast is supported by trunnions, which allow it to tilt fore and aft. Two short hydraulic cylinders are mounted between the mast and the pivot arm to control the amount of tilt. A mast indicator gauge (pointer) is located on the right side of the mast to indicate when the carriage/forks are perfectly level with the floor.

As an option, trucks may be equipped with quad masts which utilize four sets of rails, referred to as Outer, Outer Intermediate, Middle, and Inner rails, respectively.

See Figure 3-6. The primary cylinder and carriage operate the same as a triplex (three-rail) mast. When the secondary cylinders extend, they lift the middle rails. Through an intricate system of chains and sheaves, the rising middle rails pull up the outer intermediate rails at half the middle rail speed, and push up the inner rails at twice the middle rail speed.

UNDERSTANDING SLT30AC TRUCK

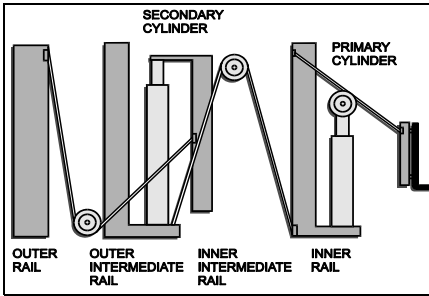

Figure 3-6: Quad Mast in Collapsed Position

Driver Controls

Driving controls for the SLT30 AC forklift truck include an accelerator pedal for speed control, foot brake pedal, tilting/telescoping steering wheel with knob, rear view mirror, driver's seat with rake adjustment and adjustable armrest, key switch, dash display, joystick (with directional control switch), horn button, wire guidance button, pivot/side-shift button, auxiliary hydraulic button and an emergency power interrupt button.

Foot Pedals

The foot pedals consists of an accelerator pedal and a brake pedal. The accelerator pedal on the right is pressed by the driver's right foot to control the speed of the truck. When pressed, the left brake pedal applies the service brakes bringing the truck to a safe STOP. See Figure 3-7.

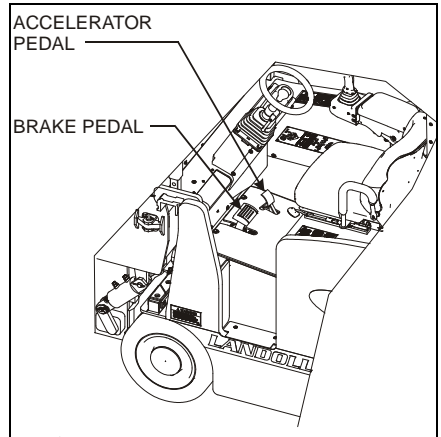

Figure 3-7: Foot Pedals

Steering Wheel and Tilt Clamp

The steering wheel is equipped with a steering knob, which should be held firmly with your left hand at all times. The steering column tilt and height are both adjustable. See Figure 3-8.

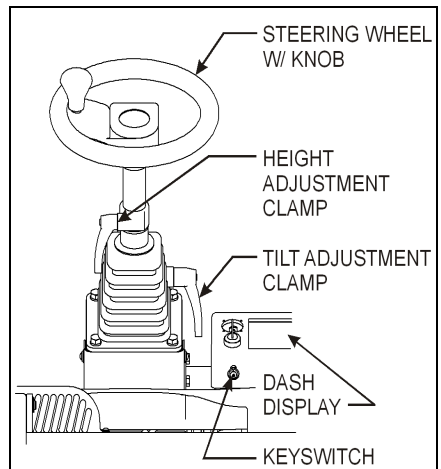

Figure 3-8: Steering Wheel and Tilt

UNDERSTANDING SLT30AC TRUCK

Driver's Seat

The driver's seat is adjustable to accommodate the driver's comfort, weight (seat cushion spring tension), backrest tilt and distance from the pedals. **See Figure 3-9.**

A lever, under the front of the seat releases the catch for forward or backward seat adjustment. To adjust the position of the seat, pull the latch lever outward and slide the seat forward or backward as needed. Release the latch lever and try to move the seat slightly forward to make sure that it is locked.

The rake adjustment has three adjustment positions.

The armrest can be adjusted fore and aft by lifting the lever on the right side of the armrest, pushing forward or backward on the armrest itself.



CAUTION

- **If the seat is not locked, it could slide forward in a sudden stop or crash, which could cause injury to the driver.**
- **Adjust the driver's seat only when the truck is NOT moving. You could lose control or the sudden movement could cause you to push a wrong pedal.**

The seat also includes a circuit interrupt safety switch. See "Seat Safety Switch" on page 1-9. A lever under the front of the seat releases the catch for forward or backward seat adjustment.

Weight or suspension adjustment is controlled by the handwheel, with a gauge showing the adjusted level, located to the right of the adjustment handwheel.

UNDERSTANDING SLT30AC TRUCK

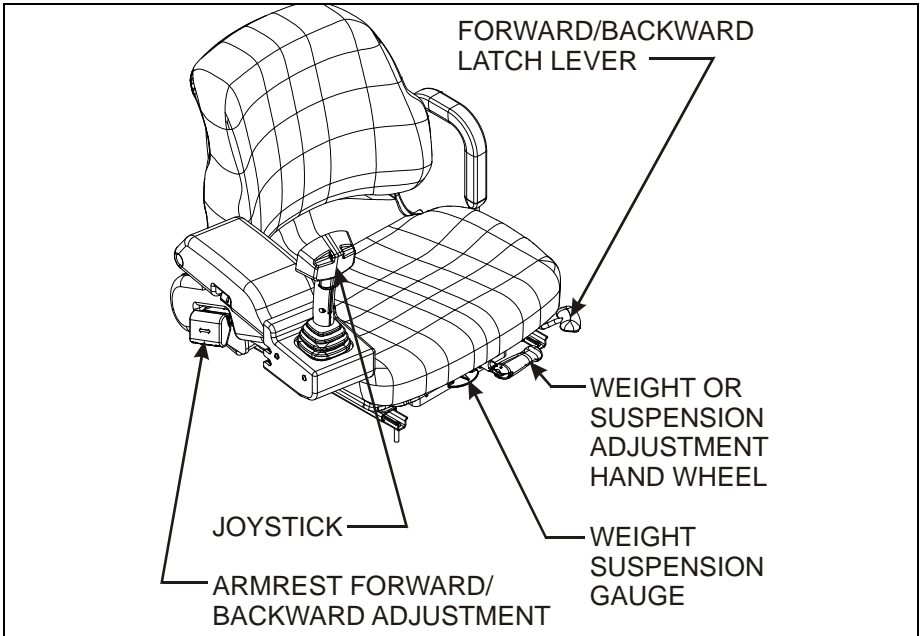

Figure 3-9: Seat Adjustments

Key switch

The key switch switches electrical power to the truck “ON” and “OFF”. See Figure 3-1.

Dash Display

The dash display is located to the right of the steering wheel. See Figure 3-1. The following items are shown on the dash instrument.

1. Lights.
2. BDI (battery discharge indicator) - shows battery capacity.
3. Clock.
4. Hourmeter - displays number of hours that the forklift has been used.
5. Fault/Error Codes – displays any faults or errors that occur.
6. Wire Guidance Status.
7. Wheel Position Indicator.
8. Diagnostics Menu.

IMPORTANT

Once the battery capacity reaches 20% the lift pump motor will shut down, thus disabling the lift function.

UNDERSTANDING SLT30AC TRUCK

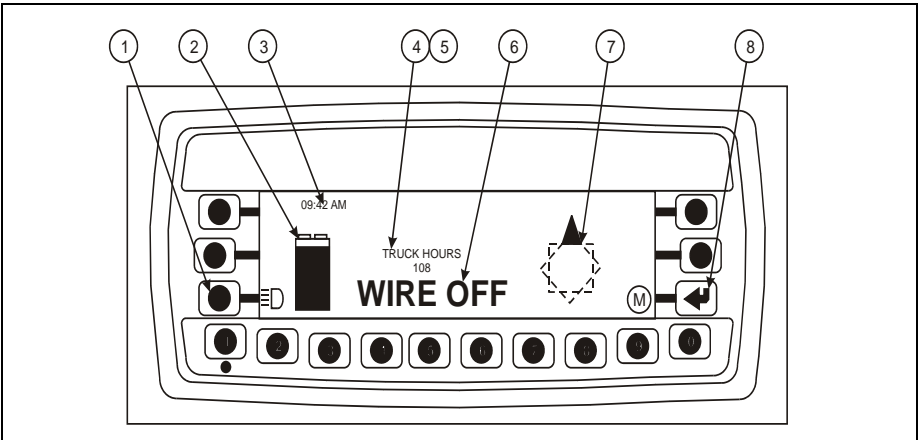

Figure 3-10: Dash Display

Joystick

The joystick is mounted to the armrest of the seat. **See Figure 3-9.**

The joystick allows you to position the forks by controlling the movements of lift/lower, tilt, pivot and side shift. In addition, the direction control switch, horn, auxiliary hydraulic control button and wire guidance button are all located on the joystick. **See Figure 3-11.**

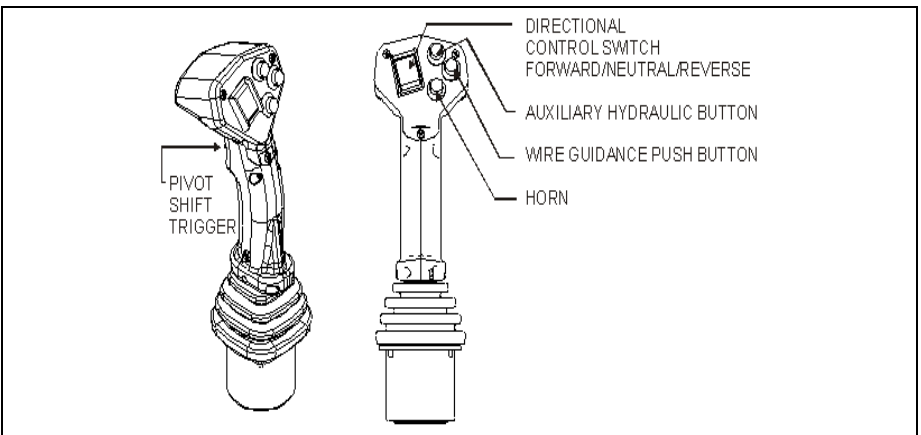

Figure 3-11: Joystick Functions

Principles of Forklift Operation

Understanding Stability



DANGER

- **NEVER** load a truck beyond its rated capacity. Loading beyond rated capacity can cause axles to break, trucks to tip over or loads to fall, causing serious injury or death. See identification plate for rated capacity and load center information.
- **NEVER** allow anyone to stand beneath or pass under the lifting mechanism. The load could fall causing serious injury or death.
- **Make sure that the load is centered and the forks are fully engaged. Failure to do so can cause the load to fall, or the truck to tip over, resulting in serious injury or death**

IMPORTANT

The leading causes of accidents involving forklift trucks are due to the lack of understanding of how forklift trucks operate, especially when it comes to stability. If you don't understand the concepts of stability, you may tip over your SLT30 AC forklift truck, which can cause serious injury or death.

Basic Principles

The concepts concerning stability are actually quite simple. As the angle between the forks and the body of the truck approaches 90° to the right, the truck is in its least stable position. **See Figure 3-12.**

Unlike an automobile, which has four points of suspension, SLT30 AC forklift trucks operate on a three-point suspension. Two of the suspension points are on the front axle (item 1 and item 2). The third suspension point is the center point of the rear wheel (item 3). The center of gravity, an imaginary point at which all of the truck's weight is concentrated, is located at point A as shown when:

- The forks are straight ahead.
- The forks are centered on the front of the truck.
- NO load is placed on the forks.
- The truck is at rest.

Imagine a triangle is drawn between the three suspension points. This triangle is commonly called the stability triangle. Since the center of gravity is an imaginary point, it will shift for various reasons that we will explore in a moment. The crucial thing to remember is, as long as the center of gravity of the truck remains within the border of the stability triangle, the truck will not tip. If the center of gravity shifts so it falls outside of the border of the stability triangle, the truck will tip around the fulcrum.

The forklift is most vulnerable in three conditions: **See Figure 3-12.**

UNDERSTANDING SLT30AC TRUCK

1. When the forks are loaded, the load is shifted to the left, and the forks are straight ahead, the center of gravity moves to a point along the axis between points (1) and (3) (center of gravity point B).
 2. When the forks are loaded, the load is shifted to the right, the center of gravity moves to a point along the axis between points (2) and (3) (center of gravity point C).
 3. When the forks are loaded and the load is too heavy or not properly distributed, the center of gravity moves to a point along the axis between points (1) and (2) (center of gravity point D).
- The load exceeds the rated capacity listed on the identification plate.
 - The load exceeds the load center dimensions listed on the capacity plate.
 - You do not seat the forks fully into the pallet, called “tip loading.”
 - You take a corner too fast, with the truck unloaded or loaded.
 - You drive with the load raised.
 - The load is not distributed properly (always keep the heavier items near the load backrest).
 - You drive across a slope.
 - You drive on a slope with the load facing downhill.

IMPORTANT

The center of gravity will also shift if:

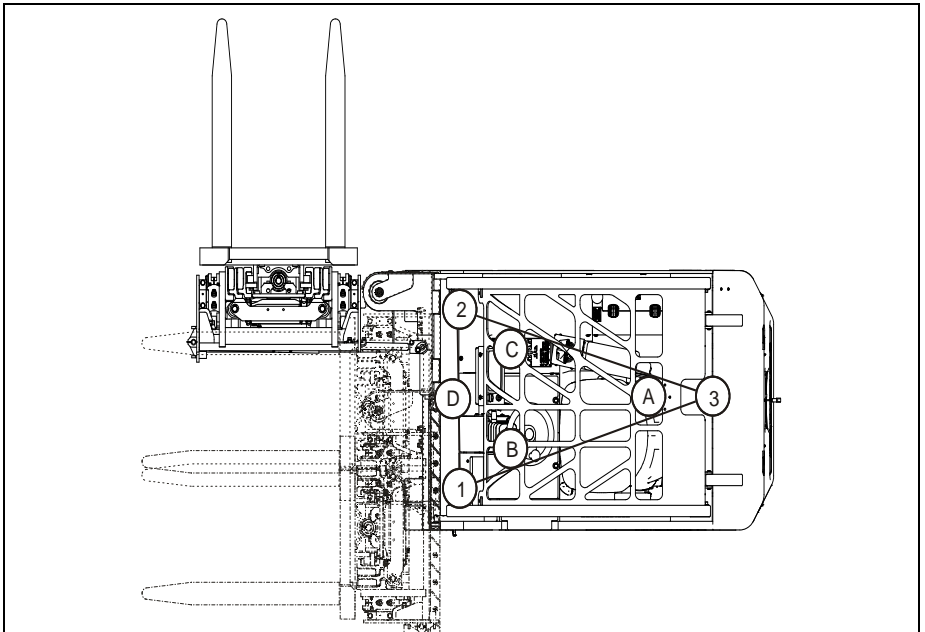

Figure 3-12: Truck Stability

UNDERSTANDING SLT30AC TRUCK

Load Center



DANGER

Ensure the horizontal and vertical load centers do not exceed the maximum load centers listed on the identification plate. Failure to do so can cause the forklift to tip, causing serious injury or death.

Two types of load centers exist:

1. The horizontal load center is equal to one-half the length of the load when the weight is evenly distributed. For example, a load that is 48 in. long has a horizontal load center of 24 in. The further the load center is from the fulcrum, the less stable the forklift becomes. Always make sure your load is flush against the rear of the forks and that unevenly distributed loads are loaded with the heaviest end of the load closest to the front wheels. **See Figure 3-12.**
2. The vertical load center is equal to one-half the height of the load when the weight is evenly distributed. For example, a load that is 48 in. high has a vertical load center of 24 in. Make sure that you do not pick up a load that is higher than twice the vertical load center.

NOTE

The maximum horizontal and vertical load centers your SLT30 AC forklift can handle is listed on the identification plate.

Counterweight



DANGER

NEVER let anyone stand on the back of the forklift to add counterweight. They can fall off the forklift or the truck can tip backwards, causing serious injury or death.

The battery, frame plates and bottom plate serve as counterweights and allow the SLT30 AC forklift to travel with heavy loads. When the forklift lifts a heavy load, the counterweights keep the center of gravity inside the stability triangle and prevent it from tipping over.

UNDERSTANDING SLT30AC TRUCK

Maximum Fork Lift Height



DANGER

The load capacity of your forklift decreases the higher you raise the forks. Refer to the rated capacity at the heights listed on the identification plate. Failure to observe these guidelines can cause your forklift to tip over causing serious injury or death.

The maximum fork height is the highest position your SLT30 AC forklift can lift a load. This is measured from the floor to the forks when they are raised in their highest position. The higher the forks are raised, the less stable the forklift becomes.

Tilting Considerations

The amount of forward and rearward tilt you should use is governed by the application. When you travel with the truck loaded, you should tilt the mast rearward as well as keep the load low. This will help stabilize loads with an uneven weight distribution. When you load at high heights, tilt the load back far enough to seat it against the load backrest or forks. When you unload at high elevations, make sure you only use enough tilt to place the load onto the rack or stack.

Attachments



DANGER

NEVER modify your SLT30 AC forklift in any manner. Only options and attachments approved by Landoll may be installed on the truck. Other modifications will void the warranty and can cause serious injury or death

Attachments to the forks may affect the load center. When the factory, dealer or distributor installs attachments approved by Landoll, an additional identification plate is attached to the truck. The new plate identifies the type of attachment, the changes in the load centers and the rated capacity. It is illegal to use attachments for which revised capacities are not available.

Determining the Load Weight

In addition to the rated capacity you must determine the weight of the load before you attempt to lift it with your SLT30 AC forklift:

- Weight listed on pallet wrapper.
- Weight is listed on Bill of Lading.
- Weight is determined by multiplying the weight of each small container by the number of small containers on a pallet. Each small container should be marked with its weight.
- When in doubt, ask your supervisor.

UNDERSTANDING SLT30AC TRUCK

Workplace Conditions



DANGER

Workplace situations may constantly change. Check your area before beginning work. If in doubt, check with your supervisor. Failure to observe new workplace conditions can lead to serious injury or death.

In addition to stability, be aware of special situations in your workplace to avoid forklift accidents. If you work in the same area each day, there could still be changes that would effect your safety, such as:

- Contractors doing maintenance.
- Wet areas.
- Overhead repair work.

Be on the defensive for anything that might present a hazard. Other situations that could present special operating conditions include:

- Potholes.
- Pedestrian traffic.
- Very narrow aisle ways.
- Overhead obstructions.
- Poor lighting making it hard to see hazards.
- Wet, oily, or uneven terrain.
- Other equipment or vehicles operating in the area.

IMPORTANT

DO NOT block the following items with your SLT30 AC forklift or materials you are moving:

- Electrical panels.
- Fire exits.
- Emergency stop buttons.
- Aisle ways.

Working in Hazardous Environments



DANGER

Some atmospheric conditions encountered in the workplace are extremely explosive and/or flammable. Make sure your SLT30 AC forklift is designated with the type appropriate for your workplace. If you are unsure about the forklift, check with your supervisor. Using the wrong type designation can cause an explosion or fire resulting in a serious injury or death.

UNDERSTANDING SLT30AC TRUCK

Atmospheric/Electrical

Special atmospheric conditions are explosive and/or flammable. If gasoline/kerosene is stored in the area vapors they produce can ignite. Make sure your SLT30 AC forklift meets the criteria for your workplace. The standard SLT30 AC forklift meets the criteria for Type “E” as described in UL 583.

Chemical Hazards

Know the chemical substances you are moving, in case of an accident. You're to handle stable, reactive or flammable substances differently. As an example, if you puncture a drum that's flammable, you need to exit the truck immediately, etc.

Operating the SLT30 AC Truck

This section of your SLT30 AC Forklift Operator's Manual discusses all concepts that must be thoroughly understood to operate a SLT30 AC forklift.

Getting On and Off the Forklift

Always maintain a three-point contact when you get on and off the forklift. Use the steps and handholds provided for this purpose. To assist you into the operator's compartment, a step (cutout) is added in the side panel.

Controls and Indicators

This section explains how each control and indicator on your SLT30 AC forklift works and identifies their location with an illustration.

NOTE

The operation of each control is established by the American Society of Mechanical Engineers (ASME) or Industrial Truck Association (ITA). If you notice that the control operation deviates from the way it is described in this manual, see your supervisor.

Driver's Seat

The driver's seat has adjustments to aide in operator comfort. Each operator should adjust the seat so they can easily reach all of the controls and operate the truck safely. Once situated in the driver's seat, the operator must fasten the seat belt.

A lever, under the front of the seat releases the catch for forward or backward seat adjustment. **See Figure 4-1.** To adjust the position of the seat, pull the latch lever outward and slide the seat forward or backward as needed. Release the latch lever and try to move the seat slightly forward to make sure that it is locked.

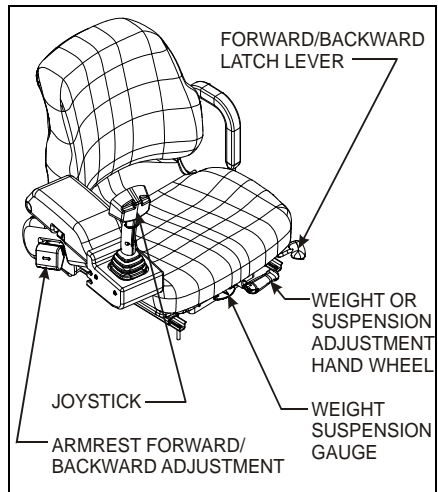

Figure 4-1: Drivers Seat Controls

Joystick Operation

Lift and Tilt Operation

Moving the joystick back will raise the forks. **See Figure 4-2.** Moving the joystick forward will lower the forks. Moving the joystick toward the right of the truck will tilt the mast assembly forward. Moving the joystick toward the left of the truck will tilt the mast assembly rearward. Multiple mast functions can be achieved by moving the lever diagonally between the two functions.

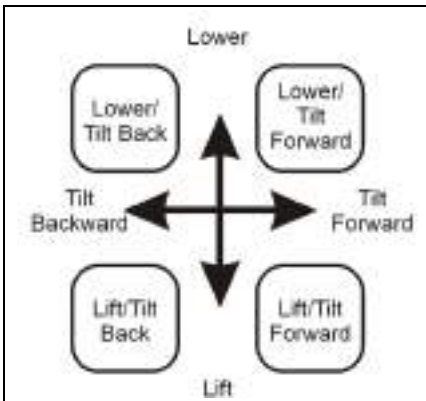

Figure 4-2: Lift and Tilt Operation

Pivot and Side Shift Operation

To operate pivot and side-shift, press and hold the pivot/shift trigger on the joystick while performing the following operations. **See Figure 4-3.** Moving the joystick toward the right side of the truck will shift the mast assembly to the right. Moving the joystick toward the left side of the truck will shift the mast assembly to the left. Moving the joystick toward the front of the truck will rotate the mast assembly away from the vehicle to the right. Moving the joystick toward the back of the truck will rotate the mast assembly toward the vehicle. Multiple pivot/shift functions can be achieved by moving the lever diagonally between the two functions.

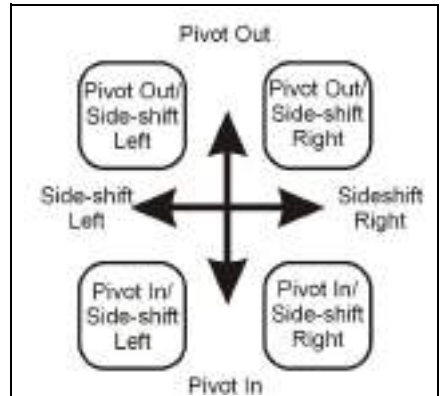

Figure 4-3 Pivot and Side Shift

OPERATING THE SLT30 AC TRUCK

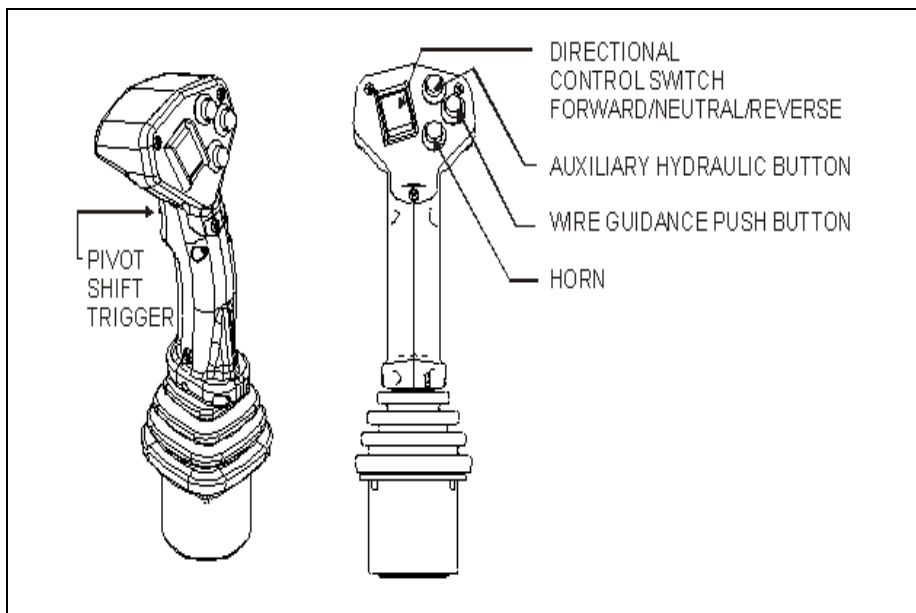

Figure 4-4: Joystick Operation

Wire Guidance Button

To activate the wire guidance system, press and release the wire guidance button location on the joystick. **See Figure 4-4.**

Auxiliary Hydraulic Function

To use the auxiliary hydraulic function for an approved attachment (such as a fork positioner or roll clamp), press and hold the auxiliary hydraulic function button on the joystick while moving it forward or backward. **See Figure 4-4.**

Direction Control Switch

The direction control switch is located on the joystick. **See Figure 4-4.** Rocking the switch forward enables the truck to go forward. Rocking the switch back allows the truck to go in reverse.

The direction control switch must be in the neutral position prior to startup.

Horn

The horn is located on the joystick. **See Figure 4-4.** Press the horn button to sound the horn.

Steering Wheel and Tilt Clamp



CAUTION

Adjusting the steering column while driving the truck is dangerous. The movement of the column could startle or confuse you causing you to lose control of the truck. Adjust the steering column only when the truck is still.

The steering wheel is equipped with a steering knob, which should be held firmly with your left hand at all times. See Figure 4-5.

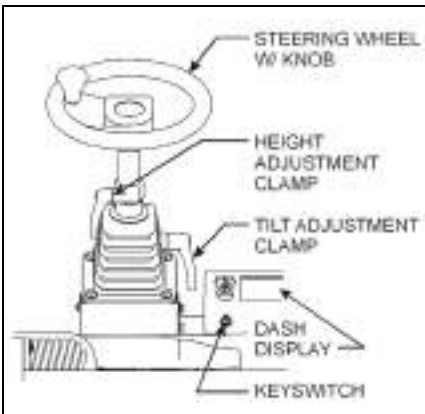

Figure 4-5: Steer Wheel & Tilt Clamp

The steering column tilt and height are adjustable.

To adjust the tilt angle, loosen the tilt clamp (or lever), adjust the angle of the steering column and tighten the tilt clamp. See Figure 4-5.

To adjust the steering wheel height, loosen the telescoping clamp (or lever), adjust the height of the steering column, and tighten the telescoping clamp. See Figure 4-5. Rock the column gently forward and back to ensure the levers are tight.

As you increase the speed of the truck the steering will get less sensitive. Also as you increase the angle of the steer wheel the maximum possible speed of the truck will be reduced. These features are both implemented to make driving the SLT30 AC truck as safe as possible.

Key Switch

The key switch is located to the right of the steering column beside the dash display. See Figure 4-5. Insert the key and rotate clockwise to operate the truck. Make sure the direction control switch is in neutral before switching on. All load controls and the accelerator should be in neutral (i.e. not depressed).

DO NOT depress the accelerator during startup.

Dash Display

The dash display is located to the right of the steering wheel. See Figures 4-5 and 4-6. It is comprised of the following features:

1. Headlights Switch (where fitted)
- Pressing this button will turn the headlights on. Once the lights are on, pressing and holding the button for 3 seconds will turn them off.

OPERATING THE SLT30 AC TRUCK

2. BDI - The BDI tells the state of the battery charge. As the battery charge decreases, the BDI level will decrease accordingly.

IMPORTANT

When the battery capacity reaches 30%, the BDI will flash, indicating the truck should be charged immediately. The lift pump motor will shut down, thus disabling the lift function when 25% of the battery is remaining.

3. Clock - This field displays the current time.
4. Hourmeter - This field displays the number of hours the truck has been operated and is based on operator presence in the seat.

5. Fault/Error Codes - If a truck error or fault occurs the information regarding the error or fault will flash in this field, alternating with the truck hours.
6. Landguide Wire Guidance System Status (where fitted) - This field gives the status of the Landguide Wire Guidance System. Operation of the Landguide system is discussed further on page 4-21.
7. Steer Wheel Position - When the direction control switch is in either the forward or reverse position this icon shows the direction the truck is travelling.
8. Diagnostics Menu - Pressing this button allows you to enter the truck diagnostic menu. Navigating through the diagnostic menu is discussed in the Maintenance Manual.

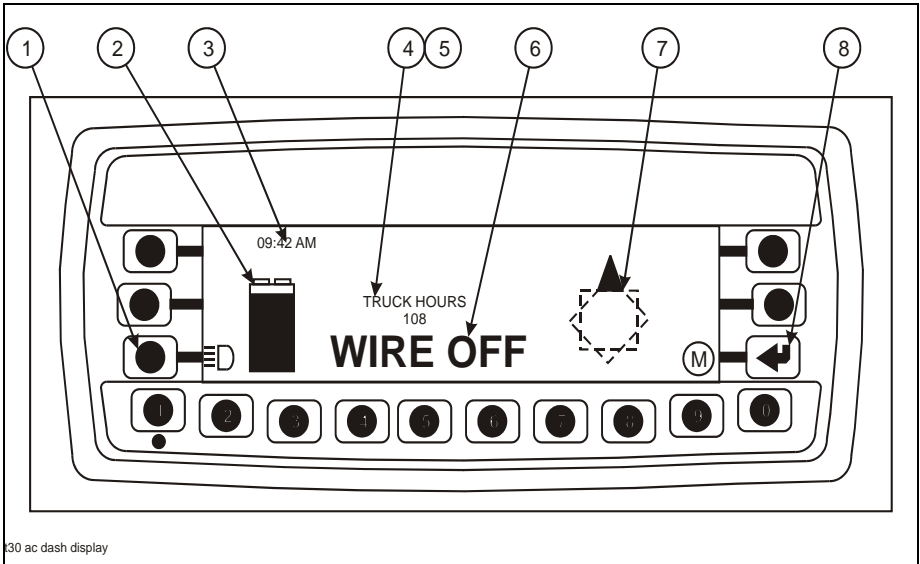

Figure 4-6: Dash Display

OPERATING THE SLT30 AC TRUCK

Accelerator Pedal

The accelerator pedal is located on the floor to the right of the brake pedal. **See Figure 4-7.**

Pressing the pedal down starts the truck moving in the direction you selected, see “Direction Control Switch” on page 4-3. The closer you press the accelerator pedal to the floor, the faster the forklift moves. Releasing the pedal brings the vehicle to a smooth stop.

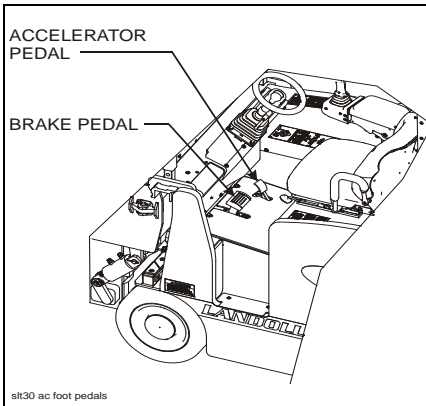

Figure 4-7 Accelerator and Brake

Brake Pedal

The brake pedal is located on the floor to the left of the accelerator pedal. **See Figure 4-7.**

Depress the brake pedal with your right foot to activate the brakes.

Parking Brake

The parking brake is a spring applied electric release brake. When the key switch is turned to the on position and the operator is in the seat, the brake is released. When the key switch is turned “OFF”, the brake engages. The brake also engages if the operator leaves the seat for three seconds. The brake engages the drive motor and will hold the truck in position.

Basic Operating Procedures



DANGER

- Review and understand all safety precautions and procedures as outlined in Chapter 1.
- Check all systems before operating this vehicle.
- Report unsafe conditions and correct them before operating the vehicle.
- **DO NOT** operate vehicle unless trained and authorized to do so.

Brakes



CAUTION

Always use your right foot for braking and **DO NOT** steer with brakes applied.

OPERATING THE SLT30 AC TRUCK



DANGER

• Failure to follow these guidelines can result in serious injury or death.

- Before you operate your SLT30 AC forklift get used to the controls and indicators and practice going forward, backward, turning, stopping and parking without a load on the truck.
- After you become familiar with the truck's operation learn how to load and unload the forklift.
- As the truck operator you are responsible for observing all speed restrictions and safely traveling in accordance with aisle and work area conditions.
- You are responsible for observing all instructions and safety regulations during your daily work routine related to the use of this truck.
- It is your responsibility to thoroughly read understand the Operator's Manual.
- Under normal driving conditions speed must be chosen according to the situation, such as surface conditions, visibility, people working in the area, moving and fixed objects in the area, cross aisles, etc. Where visibility is restricted always travel at very slow speeds and ask for a helper to guide you through the area.
- Always face in the direction you are traveling.

Driving Position



DANGER

- Only operate the vehicle from the operator's seat with the seat belt fastened.
- DO NOT place any part of your body outside the vehicle.
- DO NOT carry passengers.
- Failure to follow these guidelines can result in serious injury or death.
- Remain in your seat with the seatbelt fastened while the truck is moving. Your seatbelt will help you remain inside of the truck should it tip over. NEVER jump from the truck if it begins to tip. The truck may tip on you causing serious injury or death.

For proper seating position:

1. Adjust the driving seat for comfortable operation of the forklift controls. You must be correctly seated with all body parts inside the compartment.
2. Fasten your seat belt.

Starting and Traveling

Failure to follow this procedure will result in traction not being enabled.

1. Sit in the seat and face forward.
2. Set the direction control switch to neutral. **See Figure 4-4.**

OPERATING THE SLT30 AC TRUCK

3. Turn the key switch to the "ON" RUN position.
4. Use the joystick to raise the forks from the ground and tilt the mast back. According to ANSI B56.1, travel with the forks as low to the ground as possible. This is the recommended traveling position.

IMPORTANT

Driving with the mast in traveling position improves driver visibility and improves the stability of the truck by reducing the possibility of personal injury or damage to the load, if it were to slip from the forks.

5. Hold the steering knob firmly with your left hand. **See Figure 4-5.**
6. Set the direction of travel.
7. Gently depress accelerator control as required to achieve a safe operating speed.

Turning and Intersections



DANGER

- A lateral tip-over can occur if your truck is improperly operated.
- Slow down before turning!
- Failure to slow down can cause serious injury or death

When you reach an intersection:

- Slow down. Even if the forklift is not carrying a load it can tip-over if you turn at a high rate of speed.
- Sound the horn as you reach the intersection to warn pedestrians and other equipment operators that you are approaching the intersection.
- Always follow the rules of the road and yield to other equipment operators and pedestrians as required.

Stopping



DANGER

- **When you stop, stay inside the operator's compartment until the truck comes to a complete stop. Failure to stay inside the operator's compartment can cause serious injury or death.**
- **DO NOT** apply brakes abruptly with the load raised or tilted forward. If you stop abruptly the load may dislodge from the forks causing serious injury or death.



CAUTION

Always use your right foot for braking.

DO NOT ride the brakes.

DO NOT apply brakes while steering.

To slow down, release the accelerator and the truck will automatically slow down to creep speed. Your SLT30 AC forklift will also “brake by plugging” if you change direction with the direction control switch. The truck will come to a smooth stop and then reverse direction. This process is automatic, **DO NOT** press the brake pedal. For an emergency stop release the accelerator and press hard on the foot brake pedal with your right foot.

Stopping Distance

Stopping distance changes with the your speed, incline and quality of the road surface. To make sure you come to a safe stop:

- Reduce speed.
- Allow adequate distance between the your truck and any other vehicle, object or person.

Parking



DANGER

- When you exit the vehicle, place all controls in neutral.
- If you leave the truck unattended, fully lower the mast, turn the key switch “OFF” and remove the key.
- Failure to properly park and exit your forklift can cause serious injury or death.

Before you park the vehicle ensure:

- The parked truck will not cause an obstruction or safety hazard.
- The forklift is clear of fire exits, fire equipment and stairways.
- The truck should not be left unattended on an incline. If the truck is inoperative and you must leave it parked on an incline securely block the wheels and remove the key.

NOTE

Make sure all accessories are “OFF” (lights, etc.) before you turn the key switch to the “OFF” position.

OPERATING THE SLT30 AC TRUCK

Handling a Load

Narrow-aisles, plus the size of the truck can prevent a load from being pulled straight out of the rack. You must pivot the mast and shift (or inch) the load in or out of the rack. A combination of movements, where the pivot or shift actions occur, with forward or backward movements of the truck are needed to inch the load in and out of position. This will require some practice by the operator to be performed smoothly and effectively.



DANGER

Safety Reminders:

- Lower the load to recommended traveling position before moving. Lowering the load improves driver visibility, and improves the stability of the truck by reducing the possibility of personal injury or damage to the load should it slip from the forks.
- Look in the direction you will travel before you begin to drive the forklift.
- Ensure forks are set so the spacing between them is as wide as possible between the end stringers on the pallet and that forks fully inserted into the pallet.



DANGER

- **DO NOT** handle unstable or loosely stacked loads. Use caution when you handle high or wide loads.
- **DO NOT** allow anyone to stand beneath or pass under the mast. Never use the forklift to elevate anyone without the use of an approved attachment. Never carry passengers on the truck.
- **NEVER** load the SLT30 AC forklift beyond its rated capacity. Rated capacity is stated on the truck's identification capacity plate.
- Failure to follow these guidelines can cause serious injury or death.

Setting the Forks



CAUTION

Make certain the truck key switch is in the "OFF" position. The forks must be set equal distance from the center of the fork carriage. Setting them too far to the left or right could cause a load to unbalance and tip the truck.

Before you get on the forklift make sure the spacing between the forks is properly set. **See Figure 4-8.**

OPERATING THE SLT30 AC TRUCK

1. Measure the center to center between the fork openings on the pallet.
2. Rotate and lift the fork locks up. **See Figure 4-9.**
3. Move the forks until the center to center spacing is equal to the center to center distance. Make sure the forks are seated in a carriage notch and equidistant from the ends of the carriage. **See Figure 4-8.**

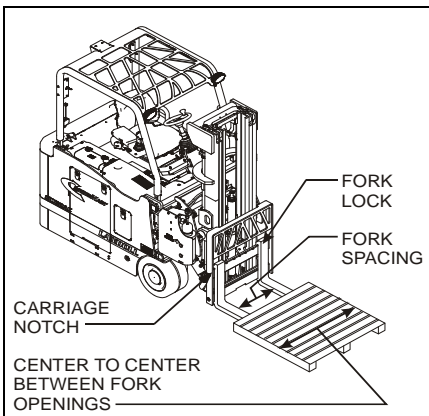

Figure 4-8: Forks Position

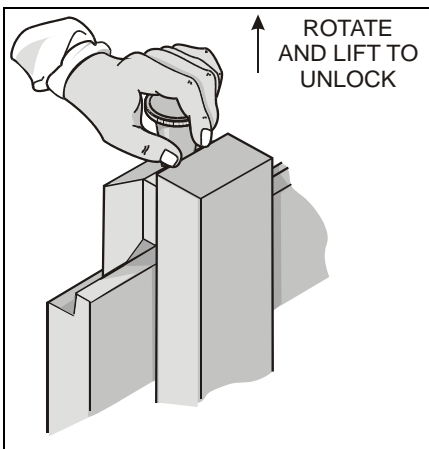

Figure 4-9: Manual Forks Adjust



CAUTION

NEVER pull a fork toward you as this places your hands in a possible pinch position, which could cause serious injury. Always push the fork away from your body.

4. Press the fork locks down to ensure locking.

Retrieving a Load

NOTE

- Actual minimum aisle width will vary based upon application. **See Figures 4-10, item 5.**
- The following illustrations show standard 40 in. x 48 in. (W x L) pallets loaded on a rack with 96 in. beams. Arrows show which direction to move the side shift and pivot.

Follow these steps to retrieve a load:

1. Approach the side of the aisle that is nearest the load. **See Figures 4-10, item 1.**
2. For narrow aisles, straighten out the truck so it is approximately 14 in. **See Figures 4-10, item 2,** from the edge of the aisle opposite the load. For wider aisles, straighten out the truck so it is 2 in. **See Figures 4-10, item 4,** from the side of the aisle where the load is located.

OPERATING THE SLT30 AC TRUCK

- Center the forks using the side shift joystick control.



DANGER

If the forks jam, load sticks or catches during a stacking operation, **DO NOT** attempt to free them by reaching through the mast. Failure to follow this guideline can cause serious injury or death.

- Drive forward until the front tips of the forks are even with the center of the pallet on the rack. See Figures 4-10, item 3.

NOTE

Limited left side aisle clearance may require pivoting the mast slightly before you can fully shift to the left.

- Lift the forks to the required height and then level the forks using the lift/tilt joystick control.

NOTE

Steps 6 through 9, although listed as separate steps, are combined together to produce one smooth motion for inserting the forks. This may require some practice to be performed smoothly and effectively.

- Carefully rotate the mast approximately 45° to the right moving the truck forward and shifting the mast to the left as needed to align the right fork (the one closest to the driver) to the opening in the pallet. The right fork must just clear the opening and the rack column. See Figure 4-11.

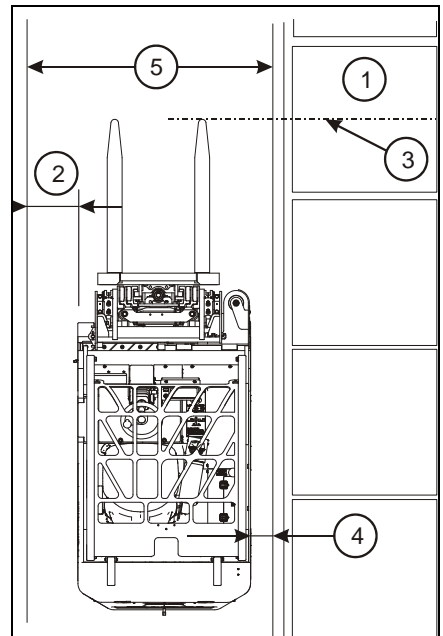

Figure 4-10: Setup - Load Pick Up

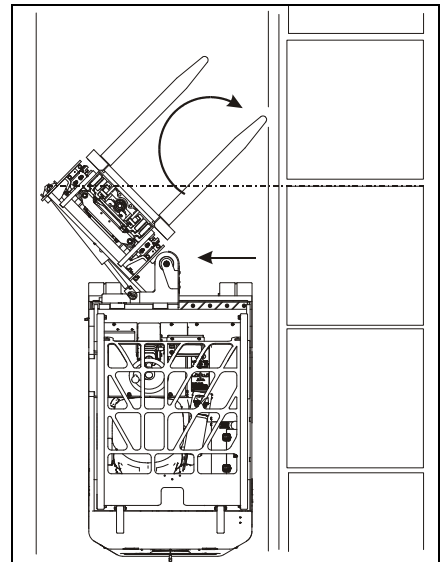

Figure 4-11: Align the Forks

- Make sure you do not strike racks or objects to your left.

OPERATING THE SLT30 AC TRUCK

8. Gradually pivot the mast to the right to align the forks to enter the pallet opening. Move the truck forward.

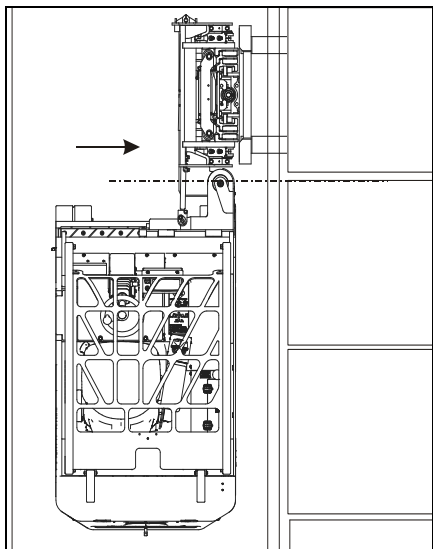

Figure 4-12: Positioning the Forks

9. When the forks are aligned to the pallet opening, shift the mast to the right, inserting the forks all the way into the pallet. See Figure 4-12.

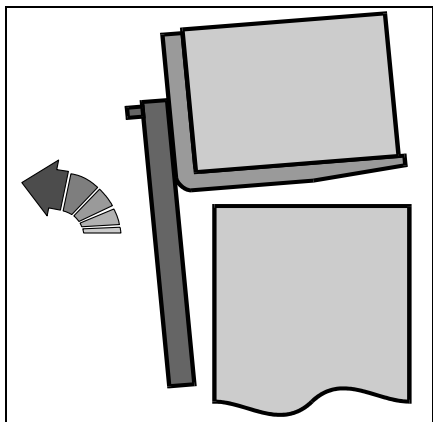

Figure 4-13: Tilting the Load

10. Tilt the mast back to make sure the load will not slide off the forks. See Figure 4-13. Raise the load only high enough to clear the rack or the load backrest may catch the rack.

NOTE

You may have to wait until the load has been withdrawn somewhat before you can tilt it completely without striking any cross-members above it.

11. Shift the load as far as possible to the left. See Figure 4-14.
12. Very slowly move the truck in reverse, simultaneously pivot the load to the left (approx. 45°) and rotate it out of the rack area. See Figure 4-15.

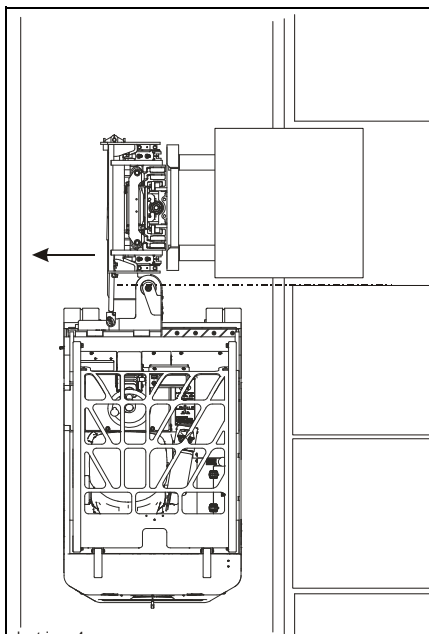

Figure 4-14: Shifting Load to Left

OPERATING THE SLT30 AC TRUCK

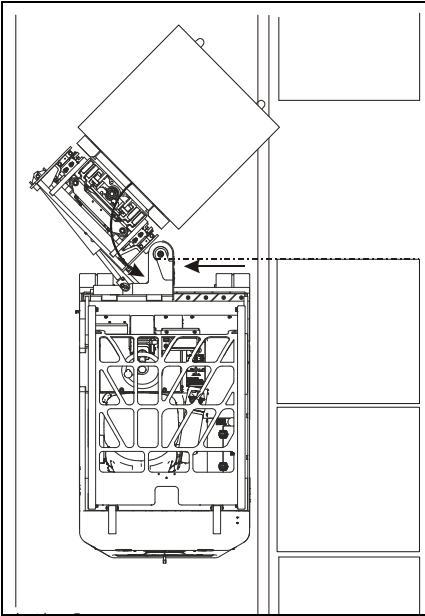

Figure 4-15: Retrieving the Pallet

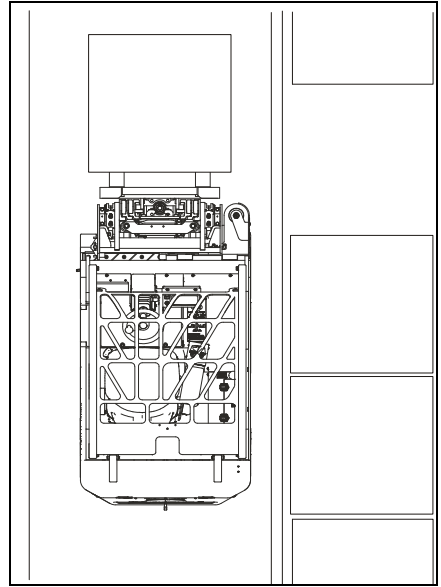

Figure 4-16: Normal Traveling Position

NOTE

The load face nearest the driver should be very close to the rack upright member as it is withdrawn.

13. When you are sure the pallet clears the rack completely, continue pivoting the mast and shifting to the right until the load is centered to the truck. **See Figure 4-16.**
14. Lower the forks to the recommended traveling position and slowly drive the truck to the next location, observing the safety rules previously stated.



WARNING

Lowering the mast improves both driver visibility and the stability of the truck by reducing the possibility of load slippage, which may cause personal injury or damage to the load.

Forklift Tipping

The following conditions can cause a forklift to tip over:

- A load exceeding the stated load centers.
- Loads too close to the fork tips.
- A load that is too heavy.
- Taking a corner too fast.
- Driving with the load raised.

OPERATING THE SLT30 AC TRUCK

- A load that is not distributed properly (keep the heavier items near the load backrest).
- Driving across a slope.
- Driving on a slope with the load facing downhill.



DANGER

Failure to follow these guidelines could cause serious injury or death.

If you sense your forklift is going to tip-over, follow these instructions:

1. Lean away from the direction the truck is tipping.
2. Hold on to the steering wheel.
3. Brace your feet.
4. Don't jump.

Turning



DANGER

- **A lateral tip-over can occur if your truck is improperly operated.**
- **Slow down before turning.**
- **Failure to slow down can cause serious injury or death.**

Follow these rules when you carry a load to help prevent the truck from tipping:

- Slow down. Your forklift can tip over if you turn at a high rate of speed.

- Sound the horn as you reach the intersection to warn pedestrians and other equipment operators you are approaching the intersection.
- Always follow the rules of the road and yield to other equipment operators and pedestrians as required.

Transporting a Load

Follow these reminder guidelines when you transport a load:

- DO NOT speed.
- Use your horn to warn others of danger.
- Make sure the load is seated firmly against the load backrest.
- Tilt the mast back.
- Lower the load to recommended traveling position before moving the load to another location.
- Be alert to overhead obstructions such as low doorways, racking, and pipes. Make sure you know the raised and lowered heights of the mast.
- Make sure the load is not wider than the width of the gangways or aisles, especially if you are backing a bulky load down an incline.

OPERATING THE SLT30 AC TRUCK

Traveling on Inclines



DANGER

- Use extra caution when operating on ramps.
- Travel slowly and **DO NOT** turn.
- Travel with the load uphill.
- Travel with empty forks downhill.
- Failure to follow these guidelines can cause serious injury or death.

When you travel up or down an incline, follow these guidelines:

- The gradient should be 10% or less.
- Always keep the load pointed uphill. Travel with the forks facing uphill whether you are going up or down an incline. That means you must back down an incline when you are carrying a load. If vision is obscured, arrange for a 'Banksman' to guide you.
- If you are not carrying a load; travel with the forks facing uphill when you are going up the incline and face the forks downhill when you are traveling down an incline.
- NEVER travel across a grade. This can cause the truck to tip-over laterally and can cause serious injury or death.
- Use the foot brake to maintain control before the truck builds up momentum.

- Raise the forks as necessary to avoid damaging the forks or load as the road surface changes grade at the top or bottom of an incline. Lower the forks back to the recommended traveling position when you clear the incline.

Unloading Your Forklift

NOTES

Actual minimum aisle width may vary based upon application. See Figures 4-10, item 5. The following illustrations show standard 40 in. x 48 in. (W x L) pallets loaded on a rack with 96in. beams. Arrows show which direction to turn the steering wheel and to move the side shift

Follow these steps to store a load:

1. Approach the side of the aisle that is nearest the area where you will unload the forklift. See **Figures 4-10, item 1.**
2. For narrow aisles, straighten out the truck so it is 14 in., See **Figures 4-10, item 2,** from the edge of the aisle opposite the drop off point. For wide aisles, straighten out the truck so it is 2 inches from the side of the aisle where the load is located. See **Figures 4-10, item 4.**
3. Center the load using the side shift joystick control.
4. Drive forward until the center of the load, See **Figures 4-10, item 3,** is aligned with the front edge of the rack opening. See **Figure 4-10.**

OPERATING THE SLT30 AC TRUCK



CAUTION

Be careful that the load does not hit the side of the rack as it is inserted. You may have to move the truck forward or backward to help provide clearance for the load to swing into the rack. Make sure the load is a few inches above the bottom rail of the rack and that it does not strike any cross members above.

5. Lift the load to the proper height making sure that you DO NOT strike the rack above.

NOTE

Steps 6 through 9, although listed as separate steps are combined together to produce one smooth motion for inserting the forks. This may require some practice to be performed smoothly and effectively.

6. Pivot the mast out (to the right) about 45° while shifting to the left as far as aisle space will allow. **See Figure 4-17.** Be careful not to hit the opposing rack.

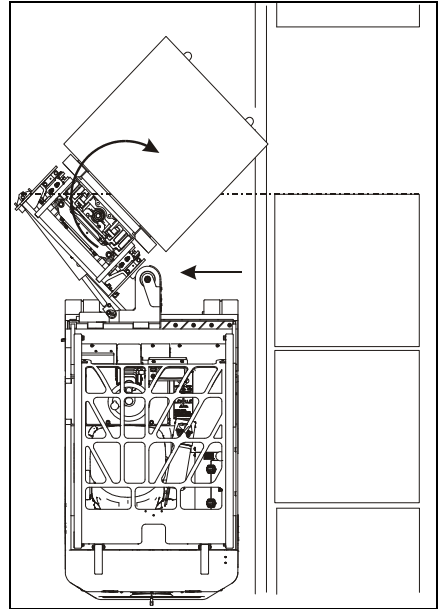

Figure 4-17: Unloading

7. Continue pivoting the mast to the right while moving the truck forward to align the load to the rack. **See Figure 4-18.**

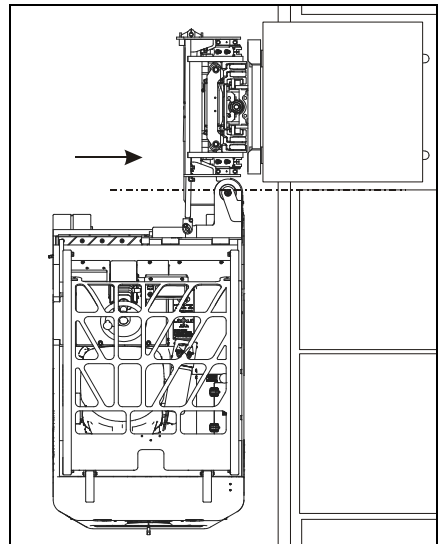

Figure 4-18: Straighten and Insert

OPERATING THE SLT30 AC TRUCK



DANGER

If the forks jam, load sticks or catches during a stacking operation, **DO NOT** attempt to free them by reaching through the mast. Failure to follow this guideline can cause serious injury or death.

8. Pivot the full 90°, and then shift to the right to place the load into the rack opening. See **Figure 4-18**.
9. Tilt the mast forward so the load is level with respect to the rack bottom, and then carefully lower the load onto the rack. See **Figure 4-19**.

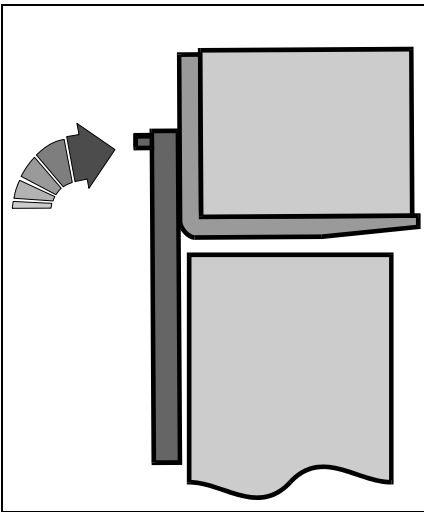

Figure 4-19: Leveling the Load

10. Carefully lower the forks until the load sits firmly on the rack. Continue to lower the forks until they no longer support the load ('no load' position). See **Figure 4-20**.

NOTE

DO NOT lower them so far that they strike the bottom of the pallet or a cross member below the load.

If the forks are lowered too far beyond the "no load" position you can damage the mast, rack or other containers on the stack.

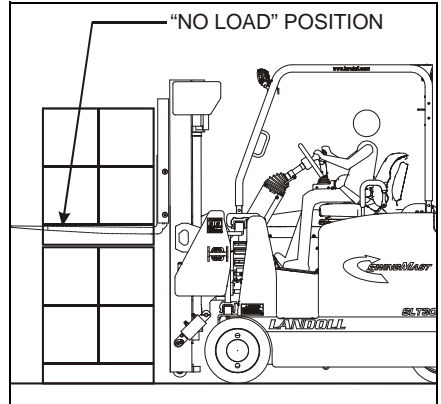

Figure 4-20: No Load Position



DANGER

DO NOT attempt to withdraw the forks until they have been lowered to a "no load" position. Failure to follow this guideline can cause the load to fall off the stack causing serious injury or death.

NOTE

DO NOT tilt the mast back until the forks clear the pallet.

11. Once the forks are in the "no load" position, shift the mast all the way to the left. See **Figure 4-21**.

OPERATING THE SLT30 AC TRUCK

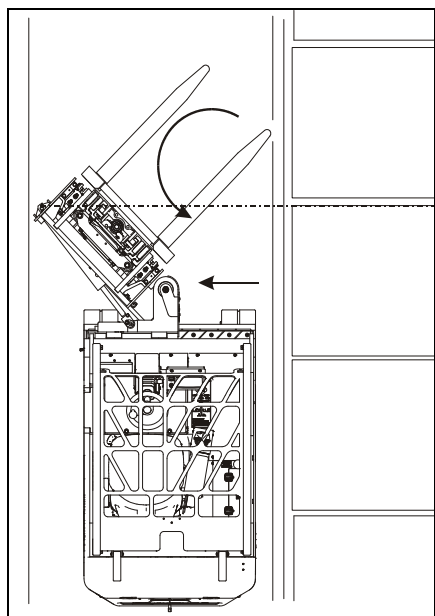

Figure 4-21: Back Up from the Load

12. Very slowly move the truck in reverse. At the same time, pivot the mast to the left (approximately 45°) to rotate the forks out of the pallet. **See Figure 4-21.**
13. Be careful that the forks do not hit the side of the rack or pallet as they emerge.
14. When empty forks clear the rack completely, continue pivoting the mast and shifting to the right until the load is centered to the truck (the normal driving position). **See Figure 4-22.**
15. Lower the forks to recommended traveling position and slowly drive the truck to the next location observing the safety rules previously stated.

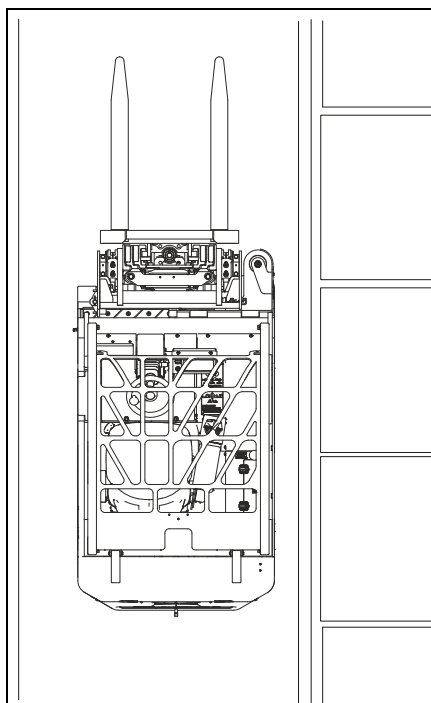

Figure 4-22: Removing the Forks

Dockboards and Trucks

Dockboards are designed and maintained so that one end contacts the dock (or loading platform) and the other end contacts the transport vehicle. When you load or unload the transport vehicle the dock board must be locked in place to prevent it from rocking or sliding. Dock boards have a high friction surface designed to reduce the possibility of people or trucks slipping.

OPERATING THE SLT30 AC TRUCK

Handholds or other effective means are provided on portable dock boards to permit safe handling. Where possible, fork loops or lugs are provided for handling by fork trucks. Special rules should be followed if your workplace uses dockboards on loading docks:

- NEVER exceed the carrying capacity marked on portable or powered dockboards.
- Portable dockboards must be secured in position, using anchors or other devices that prevent slipping.

Before you load or unload a truck or trailer make sure it does not move unintentionally by setting the brakes and blocking the wheels. In addition to setting the brakes and blocking the wheels, if a trailer is not coupled to a tractor make sure that all four corners are supported to prevent upending or corner dipping.

Maintain a safe distance from the edge of ramps, platforms or other similar working surfaces.

DO NOT move trailers with a SLT30 AC forklift.

Warning Devices

Sound the horn at an intersection. Stop and look for other vehicles and/or pedestrians and proceed with caution. Your SLT30 AC forklift may have other optional warning devices installed. Make sure they are in working order before you start work for the day:

- An amber overhead flashing beacon.
- Flashing backup light.
- Rear safety light package.
- Back up alarm.

Fire Extinguisher Option

If your truck includes a fire extinguisher it should be inspected monthly or more frequently if circumstances dictate. The extinguisher should be checked to see that:

- it is not damaged.
- the discharge outlet is not blocked.
- it is fully charged and the seal is not broken.
- the instruction pamphlet is clearly visible.

IMPORTANT

Dry-powder extinguishers are shipped fully charged. DO NOT experiment with your extinguisher since even a small amount of discharge could cause it to slowly lose the rest of its pressure, rendering the extinguisher useless.

Optional Systems Operation

Landguide Wire Guidance System

The Landguide Wire Guidance System is a vehicle controlled steering system.

Wire Guidance Operation

The Landguide Wire Guidance System goes through several modes of operation. The following paragraphs explain the various modes:

- Wire On Mode - To operate the forklift in wire guidance mode press and release the wire guidance button on the joystick. A beeper will then pulse once every second and the truck will operate in a reduced speed mode - maximum speed 2mph.
- Wire Slow Mode - Once an antenna has acquired the wire the truck will go into slow mode, as displayed in the Landguide Status field. The beeper will then pulse 3 times every second and the truck will remain in reduced speed mode. The steering wheel will lock up as the wire guidance system begins steering the truck.

- Wire Locked Mode - After both antennas have found the wire the truck will go into locked mode and the beeper will go silent. The truck will now speed up to a maximum speed of 5 mph and the steering wheel will remain locked.
- Wire Slow Mode – Once the Landguide Wire Guidance System has entered Wire Locked Mode, if one antenna loses the wire the truck will go back into Wire Slow Mode.
- Wire Fault Mode – If the Landguide Wire Guidance System is in Wire Locked Mode and both antennas lose the wire, the truck will go into Wire Fault mode. When this happens the display beeper will sound a steady alarm and the truck will come to a controlled stop. To exit the fault mode, the wire guidance button must be pushed on the joystick to turn wire guidance off and then pushed again to turn it back on.

Fork Positioner Option

The forks start at the center of the carriage and move equal distance to the outside and back again.

A push button is located on the joystick. **See Figure 4-4.**

Press and hold the button and push the joystick forward to separate the forks to the outside. Press and hold the button and pull the joystick back to bring the forks together

Operator's Daily Checklist

This section of your SLT30 AC Forklift Operator's Manual details the procedures and information the Operator will need to successfully inspect and maintain your truck on a daily basis.

Inspections Overview

Both Daily and Scheduled maintenance procedures are designed to extend the service life of the truck and prevent major problems causing costly downtime. The Daily Checklist is provided describing routine inspections, adjustments and lubrication necessary to keep your SLT30 AC fork lift operating safely, followed by details to facilitate the specific checks.

Maintenance Schedule

A detailed and rigorous full inspection maintenance schedule must be followed and is explained in the "SLT30 AC Maintenance Manual", F-459-0910. For reference an overview maintenance schedule is provided on page 5-2.

IMPORTANT

Read and comply with all applicable SAFETY precautions explained in "Safety Information" starting on page 1-1.

Recommended service inspections are based on normal operating conditions. If the truck is subject to severe or above normal operating conditions, extreme temperatures, excessive dust or wet environments, or if the truck is around corrosive materials, service must be performed more often.

OPERATOR'S DAILY CHECKLIST

Overview Maintenance Schedule

Weeks			6	12	26	52
Operating Hours	8	50	250	500	1000	2000
Check Major Structural Points	X					
Check Forks	X					
Check Fasteners and Electrical Connections	X					
Check Safety Labels	X					
Check Capacity Plate	X					
Check Static Discharge Straps	X					
Check Hydraulic Cylinders, Fittings & Hoses	X					
Check Hydraulic Oil	X					
Check Tires and Wheels	X					
Check Battery and Battery Restraint System	X					
Check Steer Column Tilt & Telescope	X					
Check Dash Display	X					
Check Seat, Belt, Slides & Switch	X					
Check Accelerator Pedal	X					
Check Service Brakes	X					
Check Parking Brake	X					
Check Steering	X					
Check All Joystick Functions	X					
Check Lift Chains	X					
Check Lights and Alarm	X					
Check Hydraulic Oil Level		X				
Check Master Cylinder Fluid Level		X				
Check Mast Settings			X			
Front Carry Position Setting			X			
Pivot Cylinder Clevis Adjust			X			
90° Pivot and Reach Setting			X			
Pivot Arm Deflection			X			
Tilt Cylinder Racking & Degree Adjust			X			
Lubricating the Truck			X			
Check Drive Transmission			X			
Check Lift Operation			X			
Check Nuts, Bolts, and Screws				X		
Change Hydraulic Oil Filter				X		
Inspect Lift Chains					X	
Chain/Roller Adjustment- Triplex Mast					X	

OPERATOR'S DAILY CHECKLIST

Primary Lift Chain					X	
Secondary Lift Chain					X	
Rail Channel Roller Inspection					X	
Carriage Channel Roller Inspection					X	
Inspect Side-shift Chains					X	
Inspect Electrical Connectors					X	
Fork Inspection					X	
Change Hydraulic Oil						X
Lubricate Front Wheel Bearings						X
Controllers						X
Lubricate Fork Positioner (Option)			X			

Daily Checklist

IMPORTANT

Daily Pre-Shift Documented Inspections are OSHA requirement. Reference page 5-2.

Report any defect immediately to your supervisor.

You are responsible for the daily inspection of your SLT30 AC forklift:

- Photocopy the "Operator's Daily Checklist" on the two following pages or use the form supplied by your supervisor.
- Inspect the truck and fill out the form.
- Report defects and return the form to your supervisor.

Operator's Daily Checklist	Condition/Operation	Status	Notes
Tires and Wheels	Check Condition		
	Torque Lug Nuts(225 ft-lbs,300 Nm)		
Static Discharge Straps	Check Condition		
Battery	Check Water, Electrolyte and Charge		
Battery Restraint System	Check Adjustment		
	Check Rollout Switch Operation		
Parking Brake	Check Operation		
Service Brakes	Check Operation		
	Check Fluid Level		
Accelerator Pedal	Check Operation		
Lift Chains	Check Condition		
Forks	Check Condition		
Electrical Fastener Connections	Check for Loose or Frayed Connections		

OPERATOR'S DAILY CHECKLIST

Hydraulic Fittings	Check Fittings and Fasteners		
Hydraulic Cylinders	Check for Leaks		
Hydraulic Hoses	Check for Wear and Leaks		
Hydraulic Oil	Check Fluid Level		
Joystick	Check Lift/Lower Control		
	Check Tilt Control		
	Check Side-shift Control		
	Check Pivot Control		
	Check Directional Switch Operation		
	Check Wire Guidance Button		
	Check Auxiliary Functions		
	Check Horn Operation		
Lights and Alarms	Check Operation		
Steering	Check Operation		
	Check Resistance		
	Check End Stops		
Steer Column Tilt/Extend	Check Operation & Torque Levers		
Dash Display - Gauges	Check BDI Operation		
	Check Hourmeter Operation		
Seat,Belt,Slides,Switch	Check Operation		
Major Structural Points	Check Overhead Guard for Cracks and Proper Tight Mounting		
	Check Frame for Cracks		
Safety Labels	Repalce as necessary		
Capacity Plate	Match Model, Serial # & Attachments		

Date	Driver	Truck#	Mod#	Loc#	Ser#	Shift	Hr. Meter	Hyd Oil

OPERATOR'S DAILY CHECKLIST

Tires and Wheels

The condition of the tires is to be checked along with the lug nut torque setting at the beginning of each shift.

The truck is equipped with tires of a size and hardness that provide the necessary traction and still maintain a proper shape to minimize tipping. To maintain stability and maximum reliability you must always replace tires with the type originally supplied, as listed on the specification sheet at the end of this manual. It is also recommended to replace worn tires in pairs. Treaded drive tires must be replaced when the tread depth is less than 0.0625" (1.6mm) at the deepest point.

1. Inspect the tire for chunking or embedded objects. **See Figure 5-1.** This is caused by running over objects on a littered floor, overloading or bad driving habits - sharp, rapid turns at high speeds or rapid starts and stops.

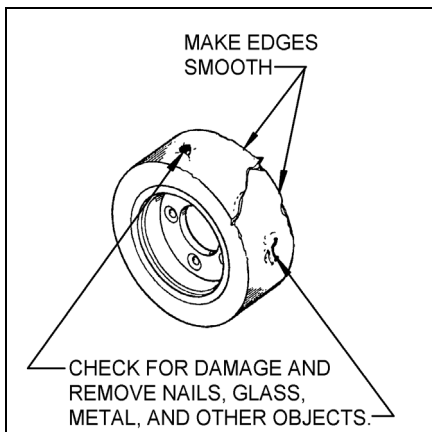

Figure 5-1: Tire wear and Damage

- Remove any embedded foreign material and torn pieces of tread as soon as it is noticed.
 - Replace chunked tires if it produces a rough bouncy ride.
2. Inspect tires for undercutting and uneven wear. Undercutting is caused by continuous overloads, rapid sharp turns, operating on slopes, a faulty steer axle, transporting loads with a high center of gravity or transporting off center loads causing the rubber to bulge out over the edge of the steel band, cutting the rubber just above the base band. Uneven tire wear is usually the result of mechanical defects, such as badly adjusted brakes, misaligned wheels, or a faulty drive axle.
 3. Check that the tires remain centered on the wheels to prevent splitting of the base band and tread separation. Correct defects as soon as possible.
 4. Flat spotting can occur from excessive heat. A load left on the forks overnight or locking the brakes with excessive skidding.
 5. Avoid oil, grease, gasoline and acid.
 6. Torque lug nuts to 225 ft.-lbs. (300Nm) and make sure no lug nuts are missing.

IMPORTANT

If tires have excessive wear and/or chunking or lug nuts are missing repair and/or have service replace immediately. DO NOT use the truck.

OPERATOR'S DAILY CHECKLIST

Static Discharge Strap(s)

At the beginning of each shift check the condition of the static straps(2) located on the front of the truck attached between the two front wheels to ensure that they are attached and are dragging the floor. Replace if missing to ensure proper truck operation. **See Figure 5-2.**

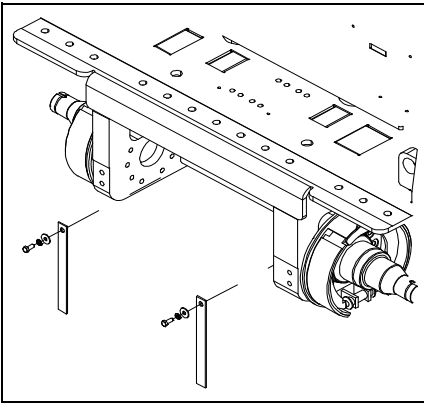

Figure 5-2: Static Discharge Straps

Battery

It is important to properly maintain the battery to ensure long life and strong voltage potential.

The truck battery contains concentrated sulfuric acid which can cause severe chemical burns. When the battery is charging it releases hydrogen, a highly explosive gas.

Shorting the battery terminals together releases enormous amounts of energy causing sparks and flames or it can heat nearby components to dangerous temperatures.

The battery is also very heavy and if restraints are not replaced after maintenance the battery could slide out of the truck causing electrical shorts and/or spilling acid. The truck could also tip.



WARNING

- **Always disconnect the battery before performing any truck maintenance and be sure to wear protective clothing and safety glasses when working with battery acid or the battery in general.**
- **Neutralize acid spills immediately with Bicarbonate of Soda. If acid contacts the skin or eyes wash with water immediately and seek medical attention at once.**
- **Use caution when changing battery connectors to ensure that the polarity is not reversed.**
- **Keep vent plugs in place and clean at all times. When replacing this battery use the same type battery as specified on the truck rating nameplate.**
- **Failure to comply could result in an unbalanced condition resulting in tipping the truck and possible injury.**
- **Be sure to close and/or tighten any battery restraints which have been installed on the truck.**

OPERATOR'S DAILY CHECKLIST



WARNING

- Always assume that the battery is emitting explosive hydrogen gas and practice proper safety precautions.
- DO NOT smoke, use open flame, create arcs or sparks near the battery.
- Consult the label on your battery for information on cell-type, ampere-hour capacity, charge rate and normal full-charge voltage.
- DO NOT charge the battery at a current greater than 1.5 amp per 100 amp-hours capacity at the end of the charge.
- Packaged with every battery are specific instructions for battery care and a Material Safety Data Sheet(MSDS). Read these documents thoroughly before performing any service to the battery.
- NEVER place any tool or metal object on top of the battery where it could possibly touch battery terminals and cause a short or serious electrical shock.

NOTE

If the truck has been shipped with the battery installed first remove the battery from the truck.

Removing the Battery From Truck

Replacing the battery requires a lift and support apparatus capable of supporting the weight and size of the battery. Check the capacity plate for battery information.

An external battery roller tray stand is also helpful and will allow the battery to be pushed into the compartment. This is available from your Landoll distributor.

To remove the battery:

1. Return the truck to your service charging area.
2. Set the key switch to "OFF" and remove the key.
3. Place blocks in front of and behind all wheels.
4. **See Figure 5-3.**
5. Remove battery door from the forklift.
6. Disconnect the battery/truck cable disconnect and lay the battery cable across the battery.
7. Remove battery restraint and slide the battery out of the truck.

OPERATOR'S DAILY CHECKLIST

If the battery has been shipped with electrolyte installed check the specific gravity of the electrolyte using a hydrometer to determine if a charge is needed. If the reading is between 1.280 and 1.290 the battery is fully charged. If the reading is near 1.150 the battery must be charged as described in "Charging a Wet Cell Battery" on page 5-8.

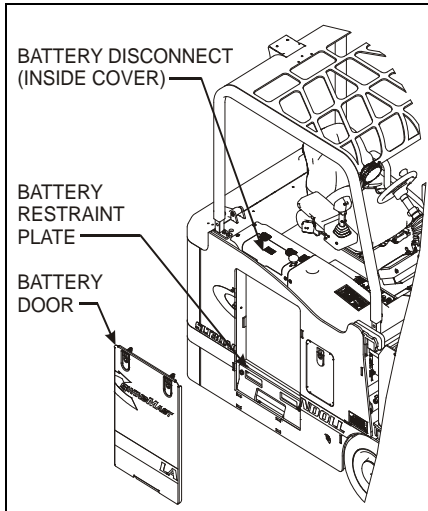

Figure 5-3 Battery Removal

Using a Hydrometer

As the battery discharges the specific gravity of the electrolyte lowers. A hydrometer allows you to check the specific gravity of the cells, thus the charge state of the battery.

To use a hydrometer:

- Remove a cap from one or two of the cells. Gently squeeze (compress) the bulb of the hydrometer.

- Insert the tube of the hydrometer into the cell electrolyte. Slowly release the bulb to allow fluid to draw into the hydrometer. Enough fluid must enter the hydrometer to allow the float to move freely.
- The specific gravity of the electrolyte is read off the scale of the float where it emerges from the fluid.
- It is good practice to select many different and multiple cells.
- When returning the electrolyte to the battery, ensure that the fluid is returned to the cell from which it was taken. Be careful not to splash the electrolyte.

Charging a Wet Cell Battery

1. Remove each vent cap and check electrolyte levels. Ambient temperature should be +77°F (+25°C) to get a proper reading. In cold weather the battery may look dry.
2. DO NOT add water until an accurate level is obtained; cold weather can affect the level. If water must be added use only distilled water.
3. Make sure the electrolyte level is at the level indicator.
4. Replace the vent caps. They must be secured in place during charging. Ordinarily, the charge should take about 3 to 5 hours to complete.

OPERATOR'S DAILY CHECKLIST

5. Charge the battery using a constant current charger set to 5% of the six-hour battery capacity. For example, 55 amps for a 1,100 AH (ampere-hour) battery.
 7. If the cell temperature rises higher than +110°F (+61.2°C), either reduce the charging current to half the original value or stop charging until the temperature falls below +110°F (+61.2°C). If you reduce the charging current extend the time accordingly.
 8. Refer to Table 5-1 for Specific Gravity correction factors dependent upon electrolyte temperature.
 9. Continue charging until the cells outgas freely and the specific gravity remains constant over a three-hour period. At the end of the charge period the cell voltages rise to about 2.55 volts and the specific gravity rises to about 1.280, corrected to 77°F.
 10. When charging is complete, ensure the vented cell caps on the battery are secure.
 11. Connect battery cables and install battery back into truck.
6. During the initial charge the volume of electrolyte decreases through electrolysis and evaporation. Water approved for use in lead-acid storage batteries should be added if the electrolyte levels falls below the level indicator.

IMPORTANT

DO NOT charge the battery at a finish current which exceeds the rating on the battery nameplate. Consult the label on your battery for information on cell-type, ampere-hour capacity, charge rate and normal full charge voltage. DO NOT charge the battery at a current greater than 1.5 amp per 100 amp-hours capacity, at the end of the charge.

Temp °F	Correction	Temp °F	Correction	Temp °F	Correction
39-41	-0.012	79-81	+0.001	119-121	+0.014
42-44	-0.011	82-84	+0.002	122-124	+0.015
45-47	-0.010	85-87	+0.003	125-127	+0.016
48-50	-0.009	88-91	+0.004	128-130	+0.017
51-53	-0.008	92-94	+0.005	131-133	+0.018
54-56	-0.007	95-97	+0.006	134-136	+0.019
57-60	-0.006	98-100	+0.007	137-139	+0.020
61-63	-0.005	101-103	+0.008	140-142	+0.021
64-66	-0.004	104-106	+0.009	143-145	+0.022
67-69	-0.003	107-109	+0.010	146-148	+0.023
70-72	-0.002	110-112	+0.011	149-151	+0.024
73-75	-0.001	113-115	+0.012	152-154	+0.025

OPERATOR'S DAILY CHECKLIST

Temp °F	Correction	Temp °F	Correction	Temp °F	Correction
76-78	0	116-118	+0.013	155-157	+0.026

Battery Restraint System

The battery restraint should be in place at all times when a battery is installed in the truck. A switch that contacts the battery restraint will disable the truck if the restraint is not in place.

Parking Brake

The parking brake system on an SLT30 AC forklift is automatically controlled by the truck's control system. To check the park brake:

1. Sit on the driver's seat and turn the key switch to "ON".
2. Put the joystick in the forward position and drive forward at a very slow speed.
3. While truck is creeping forward turn the key switch to the "OFF" position.



CAUTION

This test will cause the drive wheel to lock. DO NOT test the parking brake at high speed. Check parking brake at creep speed only.

4. The park brake should click on immediately after the key switch is turned "OFF", bringing the truck to an abrupt stop.
5. If any problems are found with the operation of the park brake immediately pull the truck from service and repair and DO NOT use the truck.

Service Brakes

With the key switch set to "ON" drive forward slowly and then steadily apply the brake pedal. The truck should stop smoothly without noticeable side pull or vibration. Any problems with the brake system must be repaired immediately.

DO NOT use the truck.

Accelerator Control

With the key switch set to "ON" and the joystick in the forward position gradually press on the accelerator. The further you press on the accelerator pedal the faster the truck will go. Let up on the accelerator and the truck should come to a controlled stop. Check to make sure the pedal does not stick or catch. If anything wrong is found remove truck from service immediately and repair.

Lift Chains

Primary Lift Chain (Duplex, Triplex and Quadplex Masts)

Visually inspect the chain for cracks, stretched or stressed links and broken pins. When raising the mast listen for usual chain noise and watch the action of the chain for anything unusual. Watch for unusual pulley movement or pulley wobble that would indicate a worn mast bearing.

OPERATOR'S DAILY CHECKLIST

Forks



CAUTION

- **DO NOT** service carriage forks while the key switch is "ON". If the joystick is accidentally moved, serious injury could occur.
- It is recommended to use only Landoll Corporation replacement parts. Use only quality forks that are forged or have an up-set heel and that have the same capacity rating as the factory installed forks.
- **NEVER** use forks repaired by welding.
- Always replace both forks. Switching forks from one truck to another can be dangerous if the capacity of the forks is not known.
- Check the forks for cracks, closely at the heel portion of the forks. Replace the fork if cracks are found. **NEVER** attempt to repair, weld or alter a fork.

Electrical Fastener Connections

Check for loose electrical connections and frayed or broken wires.

Check for loose electrical connections and frayed or broken wires.

Hydraulic Cylinders, Fittings and Hoses

Check underneath the truck for evidence of fluid leaks. Look for hydraulic hose wear, damage and leaks. Make sure clamps and fittings are tight. If leaks are found, have service repair all leaks immediately and check the hydraulic fluid level. **DO NOT** use the truck.

Hydraulic Oil

1. Lower the mast.
2. Open the access door on the right hand side of the truck and pull the dipstick and ensure the oil level reads between the marks.

NOTE

If the truck has been in operation, let the truck sit for several minutes before checking the oil level to allow time for oil to return to the tank.

3. Add oil if oil level is low.

Operator Controls

Joystick Lift/Lower Control

With the key switch turned "ON" raise the mast. The hydraulic motor should start running as soon as the control is moved out of the neutral position and stop as soon as the control returns to the neutral position. The motor should not run at all when lowering the mast.

OPERATOR'S DAILY CHECKLIST

Check that the primary mast cylinder extends fully and that the lift carriage rises to the top of the inner rails before the secondary cylinders begin to move.



WARNING

Make sure there is sufficient room above to raise the mast safely. Keep all people clear!

When the lift carriage reaches the top of the inner rails the secondary cylinders and middle rails begin lifting. Check to make sure the rails travel smoothly and that there is no chatter or visible binding.

- With the mast fully extended, begin lowering the mast. The secondary cylinders and middle rails fully lower first, followed by the primary cylinder and the lift carriage. Check for smooth travel with no chattering or visible binding.
- If there is noticeable chatter or binding immediately notify your supervisor or service personnel.
- DO NOT attempt to repair the mast or operate the truck until the problem is corrected.

Joystick Tilt Control

Move the tilt mechanism to the left and right, tilting the mast to both extents, watching for racking. Racking occurs when the tilt cylinder strokes are uneven (One cylinder bottoms before the other). The mast rails then twist, eventually causing them to crack and separate. Proper tilt degree adjust is 3° forward and 4° to 4.1° backward maximum.

1. To check for racking find a reasonably level floor area to park the truck on and center the mast on the truck.
2. Raise the mast about 36" (914 mm) from the floor and tilt the mast full forward and rearward several times watching for twisting at the ends of the stroke.
3. If there is any twisting or racking, both tilt cylinder rods must be readjusted. Remove the truck from service immediately and repair.



CAUTION

If the above scenario is left unattended serious damage to the mast assembly or the tilt cylinders can occur causing extensive repair/downtime.

Joystick Side-shift control

Hold down the trigger on the joystick and move it left and right and side-shift the mast several times back and forth to both extents. Listen for any abnormal noise that maybe caused by binding in the side-shift mechanism. If any binding is detected apply grease to the bearing pads immediately.

OPERATOR'S DAILY CHECKLIST

The side shift bearing pads are located within the slide channels above and below the side shift assembly. The channels are lined (sides, top, and bottom) with strips of low-friction plastic pads, embedded with molybdenum di-sulfide, an inorganic lubricant. During the first week of operation it is recommended to lubricate these pads once very day to allow the grease to permeate the pads completely. **See Figure 5-4.**



WARNING

DO NOT service the side-shift bearing pads while the key switch is "ON". If the control is accidentally moved serious injury could occur.

- Shift the mast to its full left position, as viewed from the operator's compartment and set the key switch to "OFF" and remove the key.
- Before lubricating the bearing pads and channels wipe off any excess lubricant and dirt buildup from within the channels.
- Using a small brush paint a thin film of grease to the sides, top and bottom of the side-shift channel surfaces reachable with the mast in this position.
- Apply a little extra grease to the top surface of the bottom channel pads.
- Turn the truck back "ON" and shift the mast to its full right position and then turn key switch back to the "OFF" position and remove key.
- Repeat grease procedure that was done on the left side.

Joystick Pivot Control

Hold down the trigger on the joystick and move it fore and aft to pivot the mast several times back and forth to both extents watching for deflection.

Deflection occurs when the pivot arm bottoms out against the stop before the cylinder has bottomed out and the cylinder is still trying to retract, thus bending the pivot arm upward.

- To check deflection swing the pivot arm out to about 45° and then bring it back in watching when it contacts the stop pad for a slight upward motion.
- Also check for a gap between the pivot arm and stop pad. If there is deflection or a gap the stop pads must be re-shimmed. If a gap is present use a feeler gauge to measure the distance of the gap to determine the correct amount of shim required. **Left unattended serious damage to the mast assembly or the pivot cylinders can occur, causing extensive repair and downtime.**

OPERATOR'S DAILY CHECKLIST

Joystick Directional Switch

Rock the directional switch forward to put the truck in forward operation. The wheel direction display on the dash should show the truck to be in the forward direction. Press on the accelerator to check. Repeat for the reverse direction by rocking the direction switch backwards.

The static return to "OFF" (SRO) is a built in safety feature to prevent accidental truck movement. To check the SRO:

1. Get in the operator's seat, drive the truck forward, and then come to a stop. Leave the directional control switch in the forward position and turn the key switch to the "OFF" position.
2. Turn key switch back to the "ON" position and then press on the accelerator. The truck should not move. Cycle the directional switch to neutral and then back to forward. The truck should now operate correctly.
3. Next, drive the truck forward and come to a stop leaving the directional control switch in the forward position.

Lift yourself out of the seat for three seconds. Sit back down and then press on the accelerator. The truck should not move without cycling the directional switch back through neutral.

Joystick Wire Guidance (Optional)

If your truck is equipped with wire guidance sit in the driver's seat and turn the truck on. Press the wire guidance button on the joystick and listen for a slow beeping noise. Also look at the dash display for WIRE ON to be displayed. If abnormalities are found remove the truck from service and repair.

Joystick Auxiliary Function (Optional)

If your truck is equipped with an auxiliary hydraulic attachment such as a fork positioner sit in the driver's seat and turn the truck "ON". Press and hold the auxiliary function button on the joysticks moving the joystick forward and aft. Watch the attachment to determine if it functions properly. If abnormalities are found remove the truck from service and repair.

Joystick Horn

Press the horn button located on top of the joystick to make certain the horn sounds when button is pushed.

Lights and Alarm

Check lights for proper on/off operation. Check that alarms sound when intended. Repair and/or replace as needed.

OPERATOR'S DAILY CHECKLIST

Steering

Before operating the truck check the steering system to make sure it operates correctly. The steering is speed sensitive, meaning it requires fewer turns of the steering wheel at lower speeds than faster speeds to turn the rear steer wheel lock-to-lock or full rotation.

To check the steering system:

1. Get in the operators seat and turn the key switch to the "ON" position.
2. Next, while moving forward or backwards slowly, turn the steering wheel clockwise until the steering wheel locks. The rear steer wheel should have turned clockwise. Repeat turning the steering wheel counterclockwise and the rear steer wheel should turn counterclockwise.
3. While turning the steering wheel there should be a little resistance felt and the steering wheel should not move once the rear steer wheel stops rotation.

Steer Column Tilt & Telescope

Before operating the truck adjust the steer column tilt and telescope in a comfortable position and torque the levers tight to ensure the steer column stays locked in place during operation.

Dash Display/ Verify Gauges

Inspect the dash display for errors or faults and ensure that the display reads normal. Check the BDI and hour meter to ensure everything looks normal. If any abnormalities are found remove the truck from service immediately for repair.

Seat, Belt, Slides & Switch

Check the seat covering for rips or cuts. Check seat belt straps for worn or frayed areas, or cuts. Make certain seat slides and adjustments lock in position. Check that the seat belt is firmly attached and that the buckle is not damaged. Check that the seat belt works properly. There is a switch in the seat that detects operator presence. The driver's seat switch system includes an interlock that shuts down the drive and power steering motors and disables the direction control (resets to NEUTRAL) bringing the truck to a Stop. The mast functions remain operable.

To check the seat switch interlock:

1. Get in the operator's seat, drive the truck forward and then come to a stop leaving the directional control switch in the forward position.

OPERATOR'S DAILY CHECKLIST

2. Lift yourself out of the seat for three seconds. You should hear the park brake click on. Sit back down and then press on the accelerator. The truck should not move without cycling the directional switch back through neutral. If this interlock does not work, remove the truck from service and repair. DO NOT use the truck.

Major Structural Points

Rust Or Corrosion

Check the truck frame, side and floor panels for rust and corrosion. Clean rusty or corroded areas and repaint, if applicable. Apply a thin coat of oil to any bare metal surface.

NOTE

Immediately pull truck from service and repair if frame cracks are found.

Overhead Guard

Check the overhead guard and make sure that it is firmly attached to the truck and that all fasteners are secured. The overhead guard is adjustable to accommodate various drivers' and operating restrictions (low ceilings, door openings, etc.).

Safety Labels

Check for damaged and missing decals. Check that the decals are legible. Clean and/or replace as needed. See page 1-4 to page 1-6.

Capacity Plate

The capacity plate should be checked to verify capacity ratings and lift heights. Also check the serial number of the truck and mast to make sure they match up with the corresponding numbers on the capacity plate. See page 3-3.

Unusual Noises

The operator, as well as the maintenance technician, should be aware and take action on any new or unusual noises that may surface. The type of noise, such a grinding or a growl, as well as the location of the noise can determine if or what type of maintenance needs to be taken. Most grinding noises may indicate a need for mast rail lubrication or a faulty wheel bearing. Growling noises can indicate faulty hydraulic pumps or simply low oil in the hydraulic tank. Any new or unusual noises should be noted in the daily check sheet and reported to the person in charge of repairs and maintenance immediately.

OPERATOR'S DAILY CHECKLIST

Recommended Lubricants

For specific areas to lubricate the forklift - See Figure 5-4.

See Table 5-1 below for recommended lubricants.

Name	Lubrication	Comments
Chain	SAE40W oil or Bowman Heavy Load Red Grease	Clean and reoil
Upright Rail	Chassis Lube or Kendall SR-12X	Lubricate inner sides of upright rails
Rotation Bearings	Mobil XHP222	Mobil XHP222
Hydraulic Reservoir	Conoco Power flow HE (ISO Grade 46) Filtered to ISO 4406 cleanliness code 15/13/11 or equivalent Grade oil filtered to 15/13/11.	Drain, flush, and refill
Gear Case	Mobilube SHC-630	Drain, flush, and refill
Articulating Axle Bearings	Mobil XHP222	Use standard lubrication gun
Load Wheel Axle	Mobil XHP222	Use lubrication gun and adapter for flush type fittings
Steering Gears	Mobil XHP222	Brush or spray on lubricant
Tilt Cylinders	Mobil XHP222	Use standard lubrication gun
Splines of the Drive Motor and Gearbox	Klubberplex BEM 34-132	Apply to splines
*Failure to refill with oil that meets ISO 4406 cleanliness code 15/13/11 may void the warranty. Typical "NEW" oil DOES NOT meet this specification. Contact Landoll Corporation or your lubricant supplier for recommendation.		

Table 5-1: Lubrication Chart

OPERATOR'S DAILY CHECKLIST

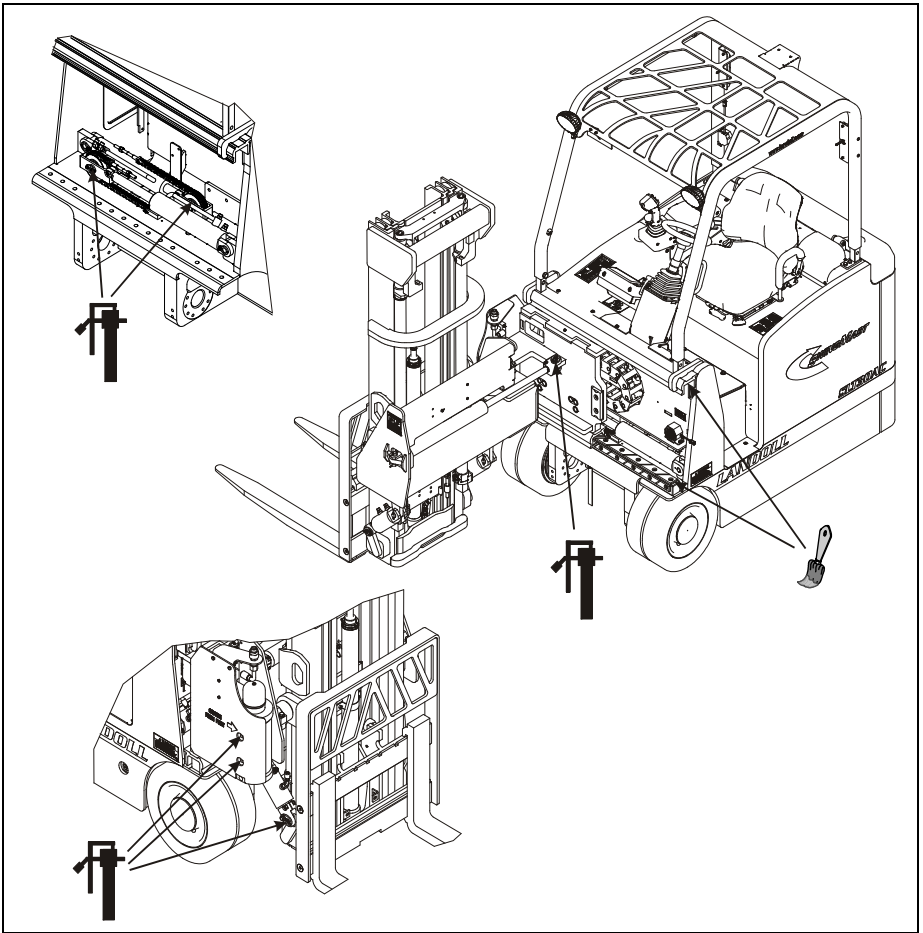

Figure 5-4: Lubrication Points

OPERATOR'S DAILY CHECKLIST

Technical Specifications

Table 5-2: Standard Specifications

Model	SLT30AC	SLT35 AC
Capacity @ 24" Load Centers	3,000 lbs. / 1,361 kg	3,500 lbs. / 1,588 kg
Load Center	24 in. / 600 mm	24 in. / 600 mm
Power Source	Battery, Electric 48V	Battery, Electric 48V
Weight w/ Battery	13,225 lbs./5,999 kg	13,550 lbs./6,146 kg
Travel Speed Loaded Unloaded	6 mph / 9.7 kph 7 mph / 11.3 kph	6 mph / 9.7 kph 7 mph / 11.3 kph
Lift Speed Loaded Unloaded	95 fpm / 29 mpm 110 fpm / 33.5 mpm	95 fpm / 29 mpm 110 fpm / 33.5 mpm
Lower Speed Loaded Unloaded	80 fpm / 24.4 mpm 75 fpm / 22.8 mpm	80 fpm / 24.4 mpm 75 fpm / 22.8 mpm
Mast Tilt (Forward/Reverse)	3° / 4°	3° / 4°
Standard Forks (ITA Class II)	40 x 4 x 1.5in. / 1016 x 101 x 38mm	40 x 4 x 1.5in. / 1016 x 101 x 38mm
Gradeability (Loaded)	10%	10%
Lift Motor Rating	12kW	12kW

OPERATOR'S DAILY CHECKLIST

Table 5-2: Standard Specifications

Model	SLT30AC	SLT35 AC
Steer Motor Rating	1.1kW	1.1kW
Traction Motor Rating	12kW	12kW
Wheel Sizes Front (2 each) Rear (1 each)	18 x 9 x 12.1 in. (457x229x307mm) 18 x 7 x 12.1 in (457x178x307mm)	18 x 9 x 12.1 in. (457x229x307mm) 18 x 7 x 12.1 in (457x178x307mm)
Battery Recommended - 48V	24-125-13, 48 Volt, 750 AHC(6 hr rate)	24-125-13, 48 Volt, 750 AHC(6 hr rate)
Battery Weight	Minimum 2,600 lb. / 1,180 kg Maximum 3,300lb. / 1,497 Kg	Minimum 2,600 lb. / 1,180 kg Maximum 3,300lb. / 1,497 Kg
Control Type Traction Hydraulic Lift	AC AC	AC AC

Technical Specifications Subject to Change

OPERATOR'S DAILY CHECKLIST

Document Control Revision Log:

Date	Revision	Improvement(s) Description and Comments
08/23/11	F-456-R1	Initial Release
10/30/12	F-456-R2	Improved layout and size
nn/nn/nn	F-	

OPERATOR'S DAILY CHECKLIST



Intertek

Equipment from Landoll Corporation is built to exacting standards ensured by ISO 9001 registration at all Landoll manufacturing facilities.

Drexel SLT 30 AC

Parts Manual

Re-Order Part Number F-456-R2

LANDOLL CORPORATION

1900 North Street

Marysville, Kansas 66508

(785) 562-5381

800-428-5655 ~ WWW.LANDOLL.COM

Copyright 2012. Landoll Corporation

“All rights reserved, including the right to reproduce this material or portions thereof in any form.”

OPERATOR'S DAILY CHECKLIST
