



Bendi®

**Model B55AC / B55AC HL
Maintenance Manual**



LANDOLL CORPORATION

1900 North Street
Marysville, Kansas 66508
(785) 562-5381

800-428-5655 ~ WWW.LANDOLL.COM

Table of Contents

1 Introduction, Safety & Specifications

Before You Begin (Please Read)	1-1
Introduction	1-1
Operating Instructions	1-1
Service Training	1-1
Tools Needed	1-1
Replacement Parts	1-1
General Maintenance Instructions	1-2
For your Safety	1-3
Lock Out/Tag Out	1-3
Battery Safety Rules:	1-3
Battery Care and Charging	1-4
Battery Removal and Installation	1-4
Hydraulic System	1-4
Towing the Truck	1-5
General Safety Tips:	1-5
Towing Vehicle Requirements	1-5
Towing a Truck in the Reverse Direction	1-5
Lifting and Blocking the Truck	1-6
Prior to Tilt Cylinder Repair	1-6
Mast Service Precautions	1-7
Lubrication Specifications	1-8
Torque Specifications	1-8
Fluid Capacities	1-8
Cleaning the truck	1-10

2 Planned Inspections

Inspection Introduction	2-1
Inspection Sheets	2-1
Tire Inspection	2-11
Visual Tire Inspection	2-11
Checking Steer Wheels	2-12

Brake System Overview	2-12
Check Service Disc Brakes	2-12
Parking Brake Lever	2-13
Checking Parking Brake Adjustment	2-13
Parking Brake Switch	2-14
Check Master Cylinder Fluid Level	2-14
Traction Drive Assemblies	2-14
Inspecting the Drive Assembly	2-14
Steering Actuator Maintenance	2-14
Check Hydraulic Oil Level	2-15
Checking and Adjusting Hydraulic Pressure	2-15
Check Power Steering	2-17
Checking Steer Pressure	2-17
Check Hydraulic Functions	2-18
Check Side Shift Circuit Performance	2-18
Electrical Contactors	2-18
Checking Batteries	2-18
Electrical Static Discharge	2-19
ESD Strap	2-19
Check the Return-to-Neutral	2-19
Check Driver's Seat Switch	2-20

3 Troubleshooting & Corrective Maintenance

Troubleshooting Charts	3-1
Corrective Maintenance	3-7
Mast & Front Rotation	3-7
Side Shift Circuit Maintenance	3-7
Hydraulic Steer Actuator Replacement	3-7
Hydraulic Steering Actuator Maintenance	3-8
Actuator Seal Lubrication	3-8
Brake System	3-9
Changing Brake Pads	3-10
Bleeding Brakes	3-10
Replacing the Brake Caliper Assembly	3-12
Repairing Brake Caliper Pistons	3-12
Disc Brakes	3-12
Disc Brake Rotors	3-12
Measuring Rotor Thickness	3-13
Check Lateral Run-Out (Warping)	3-13
Replacing the Brake Rotor Assemblies	3-13
Parking Brake Assembly	3-14
Replacing Parking Brake Lever Assembly	3-14
Replacing Parking Brake Switch	3-14
Replacing the Parking Brake Cable	3-14
Parking Brake Caliper Assembly	3-15
Changing Parking Brake Pads or Caliper	3-15

Hydraulic	3-16
Changing Hydraulic Oil	3-16
Change the Hydraulic Oil Filter	3-16
Hydraulic Motor(s) Reassembly	3-17
Hydraulic Pump Service	3-17
Hydraulic Components	3-17
Replacing the Hydraulic Pump and Motor	3-17
Hydraulic Control Valve Assembly	3-18
Hydraulic Control Valve and Switches Removal	3-18
Spool Section Rebuild	3-19
Lift Spool Sensor	3-19
Hydraulic Fittings and Hoses	3-20
Drive System	3-21
Replacing the Drive Tires	3-21
Disassembling and Inspecting Wheel Bearings	3-21
Assembling Wheel Bearings	3-21
Drive Wheel Assembly	3-22
Exposing and Maintaining the Traction Motors	3-23
Electrical	3-24
Battery - Safety, Care & Replacement	3-24
Battery Safety Rules:	3-24
Battery Care and Charging	3-25
Battery Removal and Installation	3-26
Cleaning the Battery	3-26
Battery Removal	3-26
Battery Installation	3-26
Electrical Controls and Levers	3-27
Replacing a Complete Control Panel	3-27
High Current Connections Definition:	3-28
Fuses	3-29
Steering & Pedals	3-29
Brake Pedal	3-29
Pedal Adjustments	3-30
Checking Accelerator Switch/Pot	3-31
Master Cylinder	3-31
Bench Bleed the Master Cylinder	3-32
Service Brake Pedal Assembly	3-32
Floor Plate Removal	3-33
Accelerator Pedal Assembly	3-33
Adjusting Accelerator Pedal	3-33
Replacing Accelerator Module	3-34
Power Steering System Maintenance	3-34
Filling and Air Bleeding the Power Steering System	3-34
Steering Wheel Removal	3-34
Steering Column (Console) Removal	3-35
Steering Orbital Control Unit	3-35
Steering Column/Dash Assembly	3-36
Replacing the Display Panel	3-36
Replacing the Keyswitch	3-37
Rocker (On/Off) Switches	3-37

Safety Features	3-38
Horn Control Service	3-38
Seat Assembly	3-38
Truck Lighting	3-38
Headlights	3-38
Brake and Tail Lights	3-38
Back Up Alarms	3-39
Overhead Guard, Lighting and Alarms	3-39

4 Calibration & Programming

Controller Theory of Operation	4-1
Dash Display Parameters	4-1
Truck Calibration	4-1
1314 Bendi 55 AC Controller Software Program Installation and Operation	4-3
USB to Serial Port Adaptor Cable	4-3
1314 Installation Procedure	4-5
1314 Update Procedure	4-8
Communicating with Bendi 55 AC Controllers	4-8
Controller Fault History	4-11
Familiarizing the Menus	4-12
Program's Menus	4-12
Monitoring Default Parameters	4-33
Landoll_DD_S Parameters	4-40
Landoll_P_B55 Parameters	4-44
Curtis Controller Troubleshooting	4-45
Program Troubleshooting Chart	4-46
Controller Maintenance	4-52
Controller Cleaning	4-52
Programmer Menus	4-52

5 Supplier Provided Documentation - Mast

Lift Technologies Inc.	5-1
30D-60D 3-Stage Masts	5-1
Table of Contents - page 4	5-1

6 Supplier Provided Documentation - Mast

Lift Technologies Inc.	6-1
F60 MT 3-Stage Mast (High Lift)	6-1
Table of Contents - page 4	6-1

Introduction, Safety & Specifications

Before You Begin (Please Read)

Introduction

This manual is intended for the service technician who is seeking information on product maintenance and service replacement parts. It contains troubleshooting tips and information on repair which will help the technician solve problems that may occur.

Operating Instructions

This manual does not contain operating instructions. Operating instructions are sent with each truck. If the operators manual is missing on your B55 AC truck, call Landoll Corporation to order a replacement (Part Number F-595).

Service Training

Service Training is available for the forklift technician from Landoll Corporation. This includes operation, repair, maintenance, hydraulic system, electrical system and wire guidance. Contact Landoll Corporation at www.Landoll.com for more information.

Tools Needed

The tools needed will be the same tools that are often found in well-equipped service centers, in both SAE and metric sizes. For example, an assortment of open-end and box-end wrenches, sockets, as well as Allen and adjustable wrenches, assorted screwdrivers and non-marring mallets should be available.

Replacement Parts

When ordering parts that will be used for the repair and maintenance of your Bendi B55 AC truck, the model and serial number of the truck being repaired will be required. This information is located on the serial number and capacity plate located on the right operators console. See Figure 1-1 Only Landoll parts are to be used for any repairs.

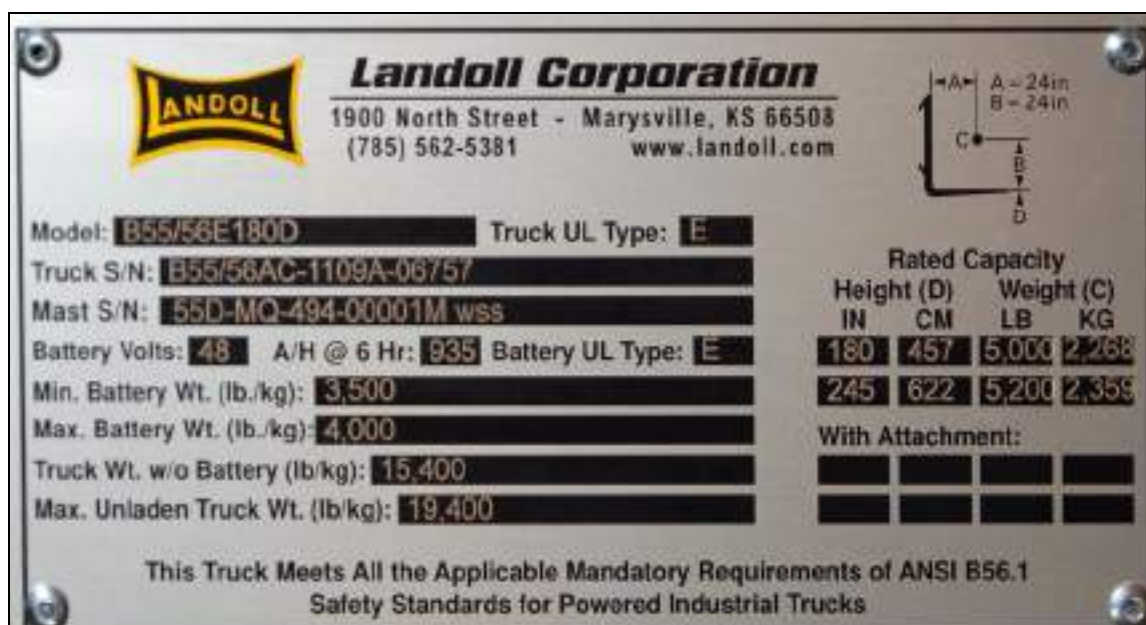

Figure 1-1: Serial and Capacity Plate

INTRODUCTION, SAFETY & SPECIFICATIONS

Below are the Notice, Caution, Warning and Danger safety notices and their descriptions that will be used in this book.

NOTICE

Special notices that include helpful maintenance hints. Read and thoroughly understand.



CAUTION

Proceed with caution. Failure to heed may cause injury to person or damage product.



WARNING

Proceed with caution. Failure to heed warning will cause injury to person or damage product.



DANGER

Proceed with extreme caution. Failure to heed danger will cause injury or death to person and/or damage to product.

General Maintenance Instructions



CAUTION

- Steel toe shoes and eye protection are required when maintaining or repairing a lift truck.
- Ear protection may also be required if the repair facilities are excessively noisy, per OSHA standards.
- Keep feet, hands and all other body parts away from all mast areas and pinch points.
- Power industrial trucks may become hazardous if scheduled maintenance is neglected. Therefore adequate maintenance facilities, as well as trained personnel and procedures, should be provided.

IMPORTANT

Maintenance and inspection shall be performed in conformance with the following practices:

1. A scheduled preventative maintenance, lubrication and inspection system should be followed. A daily check before each shift is an OSHA requirement.
2. Only qualified and authorized personnel shall be permitted to inspect, maintain and service the truck.
3. Before **leaving** the truck:
 - Stop the truck.
 - Completely lower the mast.
 - Place directional controls in neutral.
 - Turn off the power and disconnect the battery.
 - Block the wheels, especially if the truck is on an incline.
4. Before **working** on the truck:
 - Perform a Lock Out/Tag Out operation on the truck.
 - Raise drive wheel free of floor or disconnect the power sources.
 - Use chocks or other positive positioning devices.
 - Block load engaging means, inner masts or chassis before working under them.
 - Operation to check performance of truck or attachments shall be conducted in a safe clearance area.
5. Before **starting** to operate the truck:
 - Be in an operating position.
 - Place directional control in neutral.
 - Check functions of lift systems, directional control, speed control, steering, warning devices, brakes and any attachments if any are used.
6. To deter fire hazards, have fire protection equipment present. Do not use an open flame to check fluid levels or when checking for leakage of electrolyte and fluids or oil.
7. Do not use open pans of fuel or flammable cleaning fluids to clean parts.
8. Keep shop well ventilated, clean and dry.
9. Brakes, steering mechanisms, control mechanisms, lift overload devices, guards and safety devices shall be inspected regularly and maintained in safe operating condition.
10. Capacity, operation and maintenance instruction plates or decals shall be maintained in legible condition.
11. All parts of lift mechanisms shall be inspected to maintain them in safe operating condition.
12. All hydraulic systems shall be regularly inspected and maintained in conformance with good practice. Cylinders, valves and other similar parts shall be checked to assure that "drift" has not developed to an extent that it would create a hazard.

13. Batteries, motors, controllers, limit switches, protective devices, electrical conductors and connections shall be maintained in conformance with good practice. Special attention shall be paid to the condition of electrical insulation.
14. Trucks shall be kept in a clean condition to minimize risk of fire and facilitate detection of loose or defective parts.
15. Modifications and additions which affect capacity and safe truck operation shall not be performed by the customer or user without manufacturers prior written approval. Capacity, operation and maintenance plates or decals shall not be changed accordingly.
16. Care must be taken to assure that all replacement parts are interchangeable with the original parts and are of equal quality of parts that were originally installed on the truck at the factory. Landoll Replacement Parts Manual is part number F-596.
17. Be sure that any optional equipment added to the truck is positioned so that it does not block the vision of the operator or interfere with safe and efficient operation of the truck.

For your Safety

NOTICE

Lock Out/Tag Out

In the interest of operator safety and operator compliance with OSHA regulations, guidelines have been developed to perform service and maintenance on the truck.

Before performing service and maintenance on the truck, review the following sections in this manual for additional procedures to be followed.

IMPORTANT

Anytime you are doing maintenance or repair on the Landoll Bendi B55 truck, unless the truck must be on for investigative testing, remove the key from the Keyswitch console. Disconnect the battery cable connector and install a commercially available Lock Out/Tag Out device at the battery connectors because it's possible to have a duplicate key. Remove the main power fuse and install a commercially available Lock Out/Tag Out device on the battery connectors. Also, install a lockout warning reminder on the steering wheel warning that the truck is not available for use.

Battery Safety Rules:



- **Wear protective clothing, rubber apron, boots gloves and full-face shield when performing any maintenance on batteries.**
- **DO NOT allow electrolyte to come in contact with eyes, skin, clothing or floor. If electrolyte contacts eyes, flush immediately with clean water. OBTAIN MEDICAL ATTENTION IMMEDIATELY!**
- **Should electrolyte be spilled on skin, rinse promptly with clean water and soap. A baking soda solution (one pound to one gallon of water) will neutralize acid spilled on clothing, floor or other surfaces. Apply solution until bubbling stops and rinse with clean water.**
- **Keep battery vent plugs firmly in place at all times, except when adding water or taking hydrometer readings.**
- **DO NOT bring any type of flame or spark near the battery.**
- **DO NOT place any electrically conductive tool on the battery that could cause a spark. Gas formed while the battery is charging is highly explosive. This gas remains in the cells long after charging is complete.**
- **Keep the battery clean. Foreign matter in the electrolyte will result in poor battery performance.**
- **Follow the battery manufacturer's instructions concerning maintenance and repair.**

Battery Care and Charging



CAUTION

- Only qualified and experienced personnel should perform maintenance and repair on batteries.
- Make certain the charger being used matches the voltage and amperage of the truck battery. This voltage is listed on the truck serial plate. See Figure 1-1
- Before connecting or disconnecting batteries to the charger, make sure the charger is OFF. Attempts made to do this while the charger is ON could result in serious injury to the operator and damage could occur to the charger with sparks or electrical spikes.
- Keep sparks or open flame away from the battery or the charging area.
BATTERY FUMES ARE EXPLOSIVE!
- NEVER have an open flame or embers near the battery. Gas formed during charging is explosive and can cause injury. Consult the charger manufacturer's manual for operation and maintenance.
- The battery must meet size, weight and voltage requirements of the truck.

Battery Removal and Installation



CAUTION

Battery Removal:

- When removing the battery move the truck to an area intended for battery care, on a level floor.
- Turn the Keyswitch to the OFF position and remove the key.
- Disconnect battery and lock out the truck as described in the Lock Out/Tag Out section described on page 1-3.
- Never remove the battery partially from the truck without a roller stand in place.
- Lower load completely. If battery is removed with load raised, use hoist attached to mast to protect against tip over.
- DO NOT allow any metallic object to come in contact with the top of the battery. This may cause a short circuit when removing or transporting the battery. Use an insulator (such as plywood) to cover the top of the battery during removal.



CAUTION

Battery Installation:

- When installing the battery move the truck to an area intended for battery care.
- The load forks must be all the way down to the floor.
- Turn key to the OFF position and put the key in a secure place.

Good Battery Care Recommendations:

- Add approved water only - never add acid.
- Keep electrolyte levels proper.
- Keep battery top clean and dry.
- Keep flame and metal away from battery top.
- Keep vent caps tightened.
- Cool before charging/operating battery above 115°F.
- Use only an approved, correct volt/current, charger.
- Keep battery cover open while charging.
- If in doubt, call your local Landoll service technician.

Hydraulic System



WARNING

- High pressure fluids are dangerous and can puncture the skin and cause severe injury!
- Relieve all pressure from the hydraulic system before attempting to work on it.
- Make sure all hydraulic lines are tight before starting the system. Leaks in the hydraulic system can pierce the skin and cause severe injury. Any fluid injected into the skin under high pressure should be considered a medical emergency, despite the normal appearance of the skin. Medical attention should be administered immediately.

IMPORTANT

When maintenance is to be performed on the hydraulic system, make sure the system hydraulic pressure is relieved by:

- Moving the truck to a level area.
- Have no load on the forks.
- Completely lower the mast, or if the mast is the object of repair, have blocks under the mast.
- Relieve all system pressure by moving the hydraulic levers several times in both directions.

Towing the Truck

General Safety Tips:



WARNING

- Have the park brake applied when hooking up the tow chain.
- Tow the truck at a speed of 2 mph or less.
- **DO NOT** make sharp turns when towing the truck. The towed truck will be difficult to steer. **USE EXTREME CAUTION** and keep the towed vehicle at a slow, manageable speed.
- Forks must be empty and preferably not more than 12" off the floor.
- With the emergency brake disabled, the truck can roll easily - **USE EXTREME CARE!**
- Failure to reset park brakes will result in an unsafe condition.

Towing Vehicle Requirements

- Towing vehicle must have a pull and braking capacity greater than 8000 lbs.
- Brakes on towed truck may operate, but could operate differently versus an operational truck.
- Maximum towing speed should not exceed 2mph.
- Always tow the truck in the reverse direction.

Towing a Truck in the Reverse Direction

- Key must be in the OFF position.
- When attaching towing vehicle to the lift truck to be towed, a removable pin has been provided on the rear bottom side of the counter weight, see Figure 1-2. Firmly attach tow device to this pin.
- Towed vehicle's forks should be empty and no higher than 12 in. off the ground.
- Be careful. With brakes released, the forklift will roll and steering will be difficult.
- Remember that the person on the towed forklift has to turn his head to observe operations.



Figure 1-2: Forklift Tow Pin



Figure 1-3: Truck Blocking

Lifting and Blocking the Truck

- Move truck to a level area designated for repair.
- Keep forks empty and low to the ground.
- Turn the key off and remove it from the console.
- Disconnect the battery cables.
- Attach Lock Out/Tag Out device to the truck.
- Use a jack or hoist with a 10,000 lb. minimum lift to raise a single corner of the forklift.
- Set the lift on designated hardwood blocks. See Figure 1-3 for block(s) placement. Four blocks are required on all four corners of the truck to provide a safe, stable repair position.
- Keep the height of the lifted truck to a minimum.

Prior to Tilt Cylinder Repair



WARNING

- Do not place feet or hands in any area through the mast or in truck pinch points.
- Servicing the tilt cylinders requires the use of an overhead hoist, hoist slings and wheel blocks. The overhead hoist and slings must have a rating of 10,000 lb. or greater.
- Do not work under or around a truck that is not properly secured.

- Truck repair must be in a level, designated area.
- Lower the forks completely to the floor.
- Turn the truck off and observe Lockout/Tagout procedures.
- Chock wheels so that the truck cannot move.
- Attach a sling and hoist to all the top cross braces so the mast sections cannot move.

Mast Service Precautions



DANGER

- **When servicing the mast or sections of the mast, hardwood blocks (4"X4", 100 X 100mm minimum) should be used to keep individual sections of the mast from falling. In addition to the hardwood blocks, chains should be used to hold the mast sections from moving, in both the vertical and horizontal directions.**
- **Mast work to be done in a flat, designated area.**
- **NEVER walk under or stand upon forks.**
- **Remove forks before starting mast repairs.**
- **NEVER reach through the upright open areas of the mast.**
- **NEVER maintain or repair the mast without supports or while anyone is near the truck. (ASME B56.1-2000)**
- **Raise mast and position blocks under the second stage mast.**
- **Using an appropriate set of C-clamps, secure wooden blocks to mast channel.**
- **Lower mast until it sits firmly on wooden blocks.**
- **For mast inspection, use only an approved safety platform or step ladder.**
- **NEVER repair chains, they are to be replaced.**
- **NEVER replace chain sets with only one chain. All chains are to be replaced in pairs.**

To remove the mast from the forklift for service:

1. Move the truck to a level, designated area.
2. Lower forks to the floor.
3. Turn the key off and remove it from the Keyswitch.
4. Remove the forks.
5. Move all levers back and forth several times to relieve internal hydraulic pressure.
6. Slowly and carefully remove the lift and sideshift hoses. Use a container to catch oil and an oil absorbent product to absorb any spills.
7. Disconnect all wiring (if used) between the mast and the truck body.
8. Support the mast using a sling with an overhead hoist.
9. Chain the individual sections of mast together at the upper cross braces. Chain the lower mast carriage to the lower section of the mast, keeping the sections from moving when the mast is laid down on the floor.
10. Remove all pins holding the tilt cylinder to the mast.

IMPORTANT

The mast is EXTREMELY heavy. Extra care should be taken to minimize possible injury. Make sure the hoist is rated for the weight of the mast. Make sure the blocks you will lay the mast on can hold the weight. Also, be SURE that no one and no obstructions is in the path of the mast.

11. Remove mast and CAREFULLY place the mast in a horizontal position.

For mast information, refer to Chapter 5, "Supplier Provided Documentation."

Lubrication Specifications

Name	Lubrication	Notes
Mast Chain	SAE W. oil or Bowman Heavy Load Red Grease	Clean and re-oil
Mast Rail	Chassis Lube or Kendall Sr-12X.	Lube inner side of upright rail.
Steering Knob	Light weight oil	Lightly oil
Reservoir Cap	SAE 30W oil	Clean in solvent and re-oil
Hydraulic Reservoir	Mobil DTE13 (ISO Grade 32)	Drain, flush, and refill
Gear Case	Mobilube SHC-630	Drain, flush, and refill
Master Cylinder	Heavy duty brake fluid DOT 3	Check level. Add if necessary
Splines for Pump/Motor Connection	Anti-seize Compound	Apply to pump/motor connection

Torque Specifications

Component	Torque
Wheel Lug Nuts	225 ft. lbs. (346 Nm.)
Fluid draining and filling plug	16 ft. lbs. (22 Nm.)
Hydraulic braking unit	37 ft. lbs. (50 Nm.)
Drive motor with vehicle frame	130 ft. lbs. (176 Nm.)
Steering Control Unit	
Plug and o-ring assy #8 SAE fitting	44-48 ft. lbs. (60-65 Nm.)
Steer control unit assy bolt (M8 X1.0)	18-23 ft. lbs. (24-31 Nm.)
Mounting bolts	23-25 ft. lbs. (31-34 Nm.)
Steering Actuator	
Actuator Coupling	30 ft. lbs. (41 Nm.)
Actuator Mounting Bolts	460 ft. lbs. (624 Nm.)
Mast and Side Shift Mechanism	
Chain guard capscrews	48-52 ft. lbs. (65-71 Nm.)
Main lift cyl. plunger retainer	95-125 ft. lbs. (129-169 Nm.)
Free lift cyl. plunger retainer	275-300 ft. lbs. (373-407 Nm.)
Chain and hose sheave screws	26-30 ft. lb. (35-41 Nm.)
Lift chain adjusting nuts	50-70 ft. lbs. (77-95 Nm.)
Backrest screws	145 ft. lbs. (197 Nm.)
Side shift mounting hooks	115-125 ft. lbs. (156-169 Nm.)
Overhead Guard Bolts	170 Ft-lbs (230 Nm.)

Fluid Capacities

Item	Capacity - Quarts (Liters)
Hydraulic Tank	12 gallons (45 liters)
Brake Fluid	0.12 pints (0.05 liters)
Gear Box	16 oz. (0.47 liters)

General Torque Specifications (rev. 4/97)

This chart provides tightening torques for general purpose applications, when special torques are not specified on a process or drawing. Assembly torques apply to plated nuts and capscrews assembled without supplemental lubrication (as received condition). They do not apply if special graphite moly-disulfide or other extreme pressure lubricants are used. When fasteners are dry (solvent cleaned) add 33% to as received condition torque. Bolt head identification marks indicate grade and may vary from manufacturer to manufacturer. Thick nuts must be used on grade 8 capscrews. Use value in [] if using prevailing torque nuts.

Torque Specified In Foot Pounds for SAE

UNC SIZE	SAE Grade 2	SAE Grade 5	SAE Grade 8	UNF SIZE	SAE Grade 2	SAE Grade 5	SAE Grade 8
1/4-20	4 [5]	6 [7]	9 [11]	1/4-28	5 [6]	7 [9]	10 [12]
5/16-18	8 [10]	13 [13]	18 [22]	5/16-24	9 [11]	14 [17]	20 [25]
3/8-16	15 [19]	23 [29]	35 [42]	3/8-24	17 [21]	25 [31]	35 [44]
7/16-14	24 [30]	35 [43]	55 [62]	7/16-20	27 [34]	40 [50]	60 [75]
1/2-13	35 [43]	55 [62]	80 [100]	1/2-20	40 [50]	65 [81]	90 [112]
9/16-12	55 [62]	80 [100]	110 [137]	9/16-18	60 [75]	90 [112]	130 [162]
5/8-11	75 [94]	110 [137]	170 [212]	5/8-18	85 [106]	130 [162]	180 [225]
3/4-10	130 [162]	200 [250]	280 [350]	3/4-16	150 [188]	220 [275]	320 [400]
7/8-9	125 [156]	320 [400]	460 [575]	7/8-14	140 [175]	360 [450]	500 [625]
1-8	190 [237]	408 [506]	680 [850]	1-14	210 [263]	540 [675]	760 [950]
1-1/8-7	270 [337]	600 [750]	960 [1200]	1-1/8-12	300 [375]	660 [825]	1080 [1350]
1-1/4-7	380 [475]	840 [1050]	1426 [1782]	1-1/4-12	420 [525]	920 [1150]	1500 [1875]
1-3/8-6	490 [612]	1010 [1375]	1780 [2225]	1-3/8-12	560 [700]	1260 [1575]	2010 [2512]
1-1/2-6	650 [812]	1460 [1825]	2360 [2950]	1-1/2-12	730 [912]	1640 [2050]	2660 [3325]

Torque Specified In Foot Pounds for Metric

Nominal thread diameter (mm)	Low Grade in Ft. Lbs.	Grade 8.8 In Ft. Lbs.	Grade 10.9 in Ft. Lbs.	Grade 12.9 in Ft. Lbs.
6	3 [4]	7 [10]	8 [11]	10 [14]
7	5 [7]	12 [16]	17 [23]	16 [22]
8	7 [10]	17 [23]	24 [32]	24 [32]
10	13 [18]	34 [46]	48 [64]	47 [63]
12	23 [31]	58 [78]	84 [112]	81 [108]
14	36 [48]	93 [124]	134 [179]	130 [173]
16	56 [75]	145 [193]	207 [276]	202 [269]
18	78 [104]	200 [266]	286 [381]	279 [372]
20	110 [147]	283 [377]	405 [539]	394 [525]
24	190 [253]	488 [650]	699 [930]	681 [906]
27	278 [370]	716 [953]	1025 [1364]	998 [1328]
30	377 [502]	971 [1292]	1390 [1849]	1353 [1800]
33	513 [683]	1321 [1757]	1891 [2516]	1842 [2450]
36	659 [877]	1698 [2259]	2429 [3231]	2366 [3147]

Hydraulic Fitting Torque Specifications

37° JIC, ORS, & ORB (REV. 10/97)

This chart provides tightening torques for general purpose applications when special torques are not specified on a process or drawing. Assembly torques apply to plated nuts and capscrews assembled without supplemental lubrication (as received condition). They do not apply if special graphite moly-disulfide or other extreme pressure lubricants are used. When fasteners are dry (solvent cleaned) add 33% to as received condition torque. Bolt head identification marks indicate grade and may vary from manufacturer to manufacturer. Thick nuts must be used on grade 8 capscrews. Use value in [] if using prevailing torque nuts.

Torque Specified In Foot Pounds

Parker® Brand Fittings

Dash Size	37 Deg. JIC	O-ring (ORS)	O-ring boss
-4	11-13	15-17	13-15
-5	14-16	-----	21-23
-6	20-22	34-36	25-29
-8	43-47	58-62	40-44
-10	55-65	100-110	58-62
-12	80-90	134-146	75-85
-16	115-125	202-218	109-121
-20	160-180	248-272	213-237
-24	185-215	303-327	238-262
-32	250-290	-----	310-340

Gates® Brand Fittings

Dash Size	37 Deg. JIC	O-ring (ORS)	O-ring boss
-4	10-11	10-12	14-16
-5	13-15	-----	-----
-6	17-19	18-20	24-26
-8	34-38	32-40	37-44
-10	50-56	46-56	50-60
-12	70-78	65-80	75-83
-14	-----	65-80	-----
-16	94-104	92-105	111-125
-20	124-138	125-140	133-152
-24	156-173	150-180	156-184
-32	219-243	-----	-----

Aeroquip® Brand Fittings

Dash Size	37 Deg. JIC	O-ring (ORS)	O-ring boss
-4	11-12	10-12	14-16
-5	15-16	-----	16-20
-6	18-20	18-20	24-26
-8	38-42	32-35	50-60
-10	57-62	46-50	75-80
-12	79-87	65-70	125-135
-14	-----	-----	160-180
-16	108-113	92-100	200-220
-20	127-133	125-140	210-280
-24	158-167	150-165	270-360

Cleaning the truck

Landoll Corporation recommends that their fork trucks NOT be cleaned with a power washer. Electrical boards, circuitry and wiring can be damaged by high pressure water and soap. Moisture and soap left on components can rust, corrode or leave a residue that can damage everything that it comes in contact with. The preferred method of removing dust is compressed air. For localized cleaning, use a non-flammable solvent parts washer and compressed air after the part or area is cleaned.

Planned Inspections

Inspection Introduction

Preventative maintenance & planned inspections are an essential part of all industrial equipment. A well planned inspection program is essential to operator safety and truck longevity.

The inspection program designed by Landoll Corporation periodically checks the integrity of Bendi forklift systems such as:

- *Checking performance of operator functions - lift, tilt, side shift, attachment and traction systems.*
- *Checking for leaks.*
- *Checking fluid levels.*
- *Making sure components are securely attached.*
- *Checking the tires.*

Regular and preventative inspection is the responsibility of **both** the daily operator and the forklift technician.

To make sure these and other systems are checked periodically, Landoll Corporation has developed a system of checklists. A blank copy of each checklist can be found on pages 2-2 through 2-10.

These checklists include:

- *Operator's Daily Checklist*
- *1st 50 Hour Inspection Checklist*
- *1st 250 Hour Inspection Checklist*
- *500 Hour Inspection Checklist*
- *1000 Hour Inspection Checklist*
- *2000 Hour Inspection Checklist*

Except for the Operator's Daily Checklist, these tasks are usually performed by a service and maintenance facility that is approved by Landoll Corporation. These inspection sheets should be copied, completed and maintained.

IMPORTANT

Recommended inspections are based on normal operating conditions. If the truck is subjected to severe or above normal operating conditions, extreme temperatures, excessive dust or wet environments, or if the truck is around corrosive materials, inspections must be performed at shorter intervals.

Inspection Sheets

The following pages are OSHA (Occupational Safety and Health Administration) required check sheets. These sheets should be copied and the copies used for maintenance checks on your B55 AC lift. It is the operator's duty to inspect the lift before each shift and report all problems to the person in charge of forklift maintenance. Have a qualified mechanic correct all noted problems.

IMPORTANT

Daily pre-shift inspection is an OSHA requirement. These inspections must be documented.

PLANNED INSPECTIONS

Operators Daily Checklist	Status	Landoll / Bendi 55 AC
SAFETY & OPERATIONAL CHECKS Have a qualified technician correct all problems.	OK - Yes, No	Maintenance Note if Applicable
Load Backrest Extension Solidly Attached.		
Tilt Control-Forward/Reverse Functioning smoothly.		
Side Shift Control Functioning smoothly.		
Hang-on Attachment Functioning smoothly, securely attached, fittings attached.		
Steering Operation Functioning smoothly.		
Accelerator & Brake Pedal Functioning smoothly.		
Controls (Turn Power On) - Investigate Unusual noises		
Dash Display (Hour Meter, Battery Discharge Indicator, etc) Functioning Properly.		
Horn, Lights, Seat Switch Functioning Properly.		
Service and Parking Brake Functioning Properly.		
Drive Control-Forward/Reverse Functioning Smoothly.		
Battery-Check water/electrolyte level & charge - check level again after charge.		
Battery Discharge Indicator Functioning.		
Battery Restraint System - Adjust or Fasten.		
Hood and seat latch Functioning properly.		
Operator's Compartment Capacity Plate Attached - Info matches Model, Serial No. and attachments - Operator's Manual in Case.		
Seat Belt, Buckle, and Retractors Functioning Properly.		
Overhead Guard Properly mounted & attached.		
Hydraulic Oil, Battery, Brake Fluid - Check levels & look for leaks.		
Tires-Check for debris, Torque lug nuts - 225ft-lb.(305 Nm)		
Finger Guards attached.		
Major Structural Points (Front Rotation, Mast Braces, Overhead Guard) - Check for cracks.		
Hydraulic Cylinders, Pump, Valve-Check for leaks, noise.		
Safety Warnings Attached (See Manual for location).		

Date	Inspector:	Truck No.	Model No.	Location	Serial No.	Shift	Hr Meter	Battery Fluid	Hydraulic Oil

To be performed after 1st 50 hours of truck operation Fluid specifications found on page 1-8.
in addition to the required pre-shift daily inspection

Operators 1st 50 Hour Inspection	Status	Landoll / Bendi 55 AC
SAFETY & OPERATIONAL CHECKS Have a qualified technician correct all problems.	OK - Yes,No	Maintenance Note if Applicable
Mast chains-Inspect, clean and lubricate.		
Power Steering System-Inspect and Fill.		
Drive wheels, Re-Torque lug nuts 225 Ft-lbs (305 Nm).		
Gear Box-Drain, flush and refill.		
Controller - Check for any faults in "History".		

Date	Inspector:	Truck No.	Model No.	Location	Serial No.	Shift	Hr Meter	Battery Fluid	Hydraulic Oil

PLANNED INSPECTIONS

To be performed after 1st 200 hrs of truck operation
in addition to the required pre-shift daily inspection

Fluid specifications found on page 1-8.

Operators 1st 200 Hour Inspection	Status	Landoll / Bendi 55 AC
SAFETY & OPERATIONAL CHECKS Have a qualified technician correct all problems.	OK - Yes, No	Maintenance Note if Applicable
Mast - Inspect all friction surfaces and check lift chain tension.		
Lift and Tilt cylinder - Check to be sure they work together and in unison.		
Power Steering Pump - Check Operation.		
Brake Pedal - Check for free play.		
Parking & Service Brakes - Check for effectivity.		
Check Contactor Points & Micro Switches operation.		
Control Panel - Clean surface.		
Hydraulic Oil Pump - Check Operation.		
Switches (interlock, direction, parking/seat, key, pressure/temperature) - Check operation.		
Wires, Connections, Bolts and Nuts - Check.		

Date	Inspector:	Truck No.	Model No.	Location	Serial No.	Shift	Hr Meter	Battery Fluid	Hydraulic Oil

To be performed each 200 hrs of truck operation in addition to the required pre-shift daily inspection

Fluid specifications found on page 1-8.

Operators 200 Hour Inspection	Status	Landoll / Bendi 55 AC
SAFETY & OPERATIONAL CHECKS Have a qualified technician correct all problems.	OK - Yes, No	Maintenance Note if Applicable
Mast, carriage, or attachment friction surfaces - Clean, inspect for wear or damage and lubricate.		
Lift chains - Clean and lubricate.		
Extend mast - Check for excessive wear.		
Attachment control - Operational.		
Accelerator - Functioning smoothly.		
Controls (turn power on); Investigate unusual noises immediately.		
Instrument monitors - Functioning.		
Parking and service brakes - Functioning smoothly, check pads for excessive wear.		
Hydraulic fluid level - Check and fill.		
Exterior of hydraulic Tank and Oil Tank Breather - Clean.		
Hydraulic oil and hydraulic motor - Check Hydraulic motor for rough operation.		
Battery - Thoroughly clean.		
Battery box and connectors - Neutralize and clean.		
Battery - Check electrolyte level and check again after charging.		
Battery - Check structure and electrical conditions.		
Traction motors - Clean dust.		
Seat belt, buckle, and retractors - Functioning smoothly.		
Tires - Check for debris, torque lug nuts - 225 ft. lbs. (305 Nm).		
Load wheel bearings - Clean and fill with grease.		
Leaks - Hydraulic oil, battery, brake fluid, transmission.		
Hydraulic hoses and connections - Check for wear.		
Switches (interlock, direction, parking/seat, key, pressure, and temperature) - Check.		
Wire connections and sending units - Check.		
Grease fittings - Service.		
Tighten Overhead Guard Bolts - 170 ft. lbs. (230 Nm).		

Date	Inspector:	Truck No.	Model No.	Location	Serial No.	Shift	Hr Meter	Battery Fluid	Hydraulic Oil

PLANNED INSPECTIONS

To be performed each 600 hrs of truck operation in addition to the required pre-shift daily inspection

Fluid specifications found on page 1-8.

Operators 600 Hour Inspection	Status	Landoll / Bendi 55 AC
SAFETY & OPERATIONAL CHECKS Have a qualified technician correct all problems.	OK - Yes, No	Maintenance Note if Applicable
Tires - Check for debris; drive tire lug nuts - Torque to 225 ft. lbs. (305 Nm)		
Wheel bearings - Clean and fill with grease		
Leaks - Hydraulic oil, battery, brake fluid, Complete gear box		
Hydraulic hoses and connections - Check for wear		
Switches (interlock, direction, parking/seat, key, pressure, and temperature) - Check		
Wire connections and sending units - Check		
Grease fittings - Service		
Forks, top clip retaining pin and heel - Condition		
Mast rollers - No greater clearance than 1/16"		
Mast chains - Lube with SAE 40W oil or Bowman Heavy Load Red grease - Check for wear and stretch		
Steering operation - Functioning smoothly; Lubricate steering knob		
Actuator Grease Fitting - Lubricate, cycle through complete rotation twice, lubricate again		
Brake fluid - Check level		
Hydraulic oil filter - Change element and check for proper level - Check pressures		
Battery - Check Electrolyte levels and check for physical damage		
Contact points and Micro Switches - Check operation		
Control panel - Clean surface		
Operator's compartment capacity Plate Attached - Information matches model, serial no., and attachments		
Check all connections for proper torque		

Date	Inspector:	Truck No.	Model No.	Location	Serial No.	Shift	Hr Meter	Battery Fluid	Hydraulic Oil

To be performed each 1000 hrs of truck operation in addition to the required pre-shift daily inspection.

Continued onto the next page for clarity.
Fluid specifications found on page 1-8.

Operators 1000 Hour Inspection	Status	Landoll / Bendi 55 AC
SAFETY & OPERATIONAL CHECKS Have a qualified technician correct all problems.	OK - Yes, No	Maintenance Note if Applicable
Mast, carriage, or attachment friction surfaces - Clean, inspect for wear or damage, and lubricate.		
Lift chains - Clean and lubricate.		
Extend mast - Check for excessive wear.		
Attachment control - Operational.		
Accelerator - Functioning smoothly.		
Controls (turn power on); Investigate unusual noises immediately.		
Instrument monitors - Functioning.		
Parking and service brakes - Functioning smoothly, check pads for excessive wear.		
Hydraulic fluid level - Check and fill.		
Exterior of hydraulic tank and oil tank breather - Clean.		
Battery - Thoroughly clean.		
Battery box and connectors - Neutralize and clean.		
Battery - Check electrolyte level.		
Battery - Check structure and electrical conditions.		
Traction motors - Clean dust.		
Seat belt, buckle, and retractors - Functioning smoothly.		
Tires - Check for debris, torque lug nuts to 225 ft. lbs. (305Nm).		
Wheel bearings - Clean and fill with grease.		
Leaks - Hydraulic oil, battery, brake fluid, complete transmission.		
Hydraulic hoses and connections - Check for wear.		
Switches (interlock, direction, parking/seat, key, pressure, and temperature) - Check.		
Wire connections and sending units - Check.		
Grease fittings - Service.		
Forks, top clip retaining pin and heel - Condition.		
Mast rollers - No greater than 1/16".		
Mast chains - Lube with SAE 40W oil or Bowman Heavy Load Red grease - Check for wear and stretch.		
Steering operation - Functioning smoothly; Lube knob.		
Actuator grease fittings - Lubricate, cycle through complete rotation twice, lubricate again.		
Brake fluid - Check level.		
Hydraulic oil filter - Change element and check for proper level - Check pressures. Steer - 1900 psi Mast - 2600-2800 psi		
Battery - Check voltage between truck body and negative/positive terminal.		
Battery rollers - Remove, clean, and repack (optional).		

PLANNED INSPECTIONS

Operators 1000 Hour Inspection	Status	Landoll / Bendi 55 AC
Contactor points and Micro Switches - Check operation.		
Control panel - Clean surface.		
Check all connections for proper torque.		
Motor - Check that terminal studs and mounting bolts are clean and tight.		
Motor - Clean cooling holes of debris or restrictions.		
Operator's compartment capacity plate attached - Check information matches model, serial number and attachments.		

Date	Inspector:	Truck No.	Model No.	Location	Serial No.	Shift	Hr Meter	Battery Fluid	Hydraulic Oil

To be performed each 2000 hrs of truck operation in addition to the required pre-shift daily inspection.

Continued onto the next page for clarity.
Fluid specifications found on page 1-8.

Operators 2000 Hour Inspection	Status	Landoll / Bendi 55 AC
SAFETY & OPERATIONAL CHECKS Have a qualified technician correct all problems.	OK - Yes, No	Maintenance Note if Applicable
Mast, carriage, or attachment friction surfaces - Clean, inspect for wear or damage, and lubricate.		
Lift chains - Clean and lubricate.		
Extend mast - Check for excessive wear		
Attachment control - Operational.		
Accelerator - Functioning smoothly.		
Controls (turn power on); Investigate unusual noises immediately.		
Instrument monitors - Functioning.		
Parking and service brakes - Functioning smoothly, check pads for excessive wear.		
Hydraulic fluid level - Check and fill.		
Exterior of hydraulic tank and oil tank breather - Clean and Check.		
Hydraulic oil, Hydraulic lift pump and power steering pump - Check commutator surface for roughness.		
Battery - Thoroughly clean.		
Battery box and connectors - Neutralize and clean.		
Battery - Check electrolyte level.		
Battery - Check structure and electrical conditions.		
Traction motors - Clean dust.		
Seat belt, buckle, and retractors - Functioning smoothly.		
Tires-Check for debris, torque lug nuts to 225 ft. lbs. (305nM).		
Wheel bearings - Clean and fill with grease.		
Leaks - Hydraulic oil, battery, brake fluid, complete transmission.		
Hydraulic hoses and connections - Check for wear.		
Switches (interlock, direction, parking/seat, key, pressure, and temperature) - Check.		
Wire connections and sending units - Check.		
Grease fittings - Locate, Check and Service all zerks.		
Forks, top clip retaining pin and heel - Condition.		
Mast rollers - No greater than 1/16".		
Mast chains - Lube with SAE 40W oil or Bowman Heavy Load Red grease - Check for wear and stretch.		
Steering operation - Functioning smoothly; Lube knob.		
Actuator grease fittings - Lubricate, cycle through complete rotation twice, lubricate again.		
Brake fluid - Check level.		
Hydraulic oil filter - Change element and check for proper level - Check pressures. Steering - 1900 psi Mast - 2600-2800 psi.		
Battery rollers (optional) - Remove, clean, and replace bad rollers.		
Contact points and Micro Switches - Check operation		
Control panel - Clean surface.		
Operator's compartment capacity plate attached - Check Information matches model, serial no., and attachments.		

PLANNED INSPECTIONS

Operators 2000 Hour Inspection	Status	Landoll / Bendi 55 AC
Check all connections for proper torque.		
Motors - Check that terminal studs and mounting bolts are clean and tight.		
Motors - Clean cooling holes of debris or restrictions.		
Gear box - Drain, flush, and refill.		
Hydraulic oil - Change.		
Hydraulic reservoir suction screen - Clean with solvent.		

Date	Inspector:	Truck No.	Model No.	Location	Serial No.	Shift	Hr. Meter	Battery Fluid	Hydraulic Oil

Tire Inspection



WARNING

The truck is equipped with tires of a size and hardness that provide the necessary traction and still maintain a proper shape to minimize tipping. To maintain stability and maximum reliability, you must always replace tires with the type originally supplied and torqued to specification as listed on the specification sheet on page 1-8.

IMPORTANT

It is recommended to replace worn tires in pairs. Treaded drive tires must be replaced when the tread depth is less than 0.0625" (1.6mm) at the deepest point.

Careful driving habits add additional miles to tire life.

NOTE

- Check all wheel nuts after 2 to 5 hours of operation when new lift trucks begin operation and on all lift trucks when the drive wheels have been removed and re-installed.
- Tighten the nuts in a cross pattern to the correct torque value shown on page 1-8.
- When the nuts stay tight for eight hours, the interval for checking the torque can be extended to 200 hours.

Visual Tire Inspection

1. Inspect the tires for chunking (or chipping), embedded foreign material (wire, rocks, glass, metal, etc.), cuts, gouges, undercutting or uneven wear. Remove any object that will cause damage.
2. Check for loose or missing hardware.
3. Remove any wire strapping or other material that is wrapped around the inside of the wheel.
4. Make sure drive wheel nuts are tight. Tighten the wheel nuts in a cross pattern to a correct torque value (225 ft. lbs (305 Nm)).

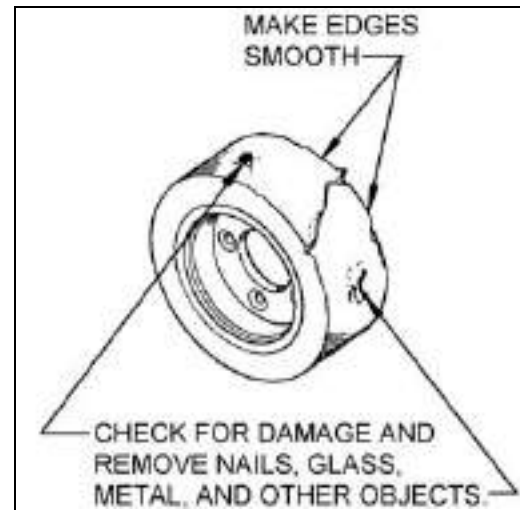

Figure 2-1: Tire Damage Types

Chunked tires or Embedded Objects

- Chunking, or chipping is caused by repeatedly running over objects on a littered floor which can chip away or produce deep cuts to the rubber surface of the tire. Embedded objects, such as glass, metal chips, or nails left in a tire, and truck overloading cause the same effect.
 - Sharp, rapid turns at quick speeds, jack-rabbit starts and stops and other such bad driving habits can cause the same kind of damage.
1. Remove any embedded foreign material from the tire as soon as it is noticed. Also remove torn pieces of tread.
 2. To avoid overloading, always center the payload on the truck to equalize the load on all tires. Do not dangle the load on the ends of the forks. Also avoid fast cornering, which can cause an overload affect.
 3. If the tires are chunked bad enough to produce a bouncy ride, replace them.

Undercutting and Uneven Wear

- Undercutting is caused by continuous overloads, rapid, sharp turns, operating on slopes, a faulty steer axle, transporting loads with a high center of gravity, or transporting off-center loads.
 - Uneven tire wear is usually the result of mechanical defects, such as badly adjusted brakes, misaligned wheels (misaligned steer axle), or a faulty drive axle.
1. Undercutting causes the rubber to bulge out over the edge of the steel band, cutting the rubber just above the base band.
 2. Check that the tires remain centered on the wheels to prevent splitting of the base band and tread separation.
 3. Correct defects as soon as possible.

Flat-spotting

Flat-spotting occurs when:

- The truck has been sitting idle for some time after heavy use and is usually caused by the tires overheating.
 - The truck has standing loads (loads left on the forks overnight).
 - Locking the brakes while traveling in either direction on grades (slopes), with or without a load, causing excessive skidding. Polyurethane tires are extremely susceptible to this type of abuse.
1. Avoid excessive heat. Where possible, avoid contact with hot metal or operation for long periods in hot oven rooms. Excessive heating will break-down the tire structure. Shields which prevent heat from striking tires directly will often prolong life.
 2. Avoid standing loads. Solid tires will flat-spot when loads are left standing on the truck overnight. In extreme cases, a flat spot develops and the tire bounces with every revolution.
 3. If the tires are flat-spotted bad enough to produce a bouncy ride, replace them.
 4. Do not indulge in stunt driving or horseplay where excessive hard braking is needed, especially on grades (slopes).

Extending Tire Life

A few simple measures can help increase tire life and reduce maintenance (downtime) and cost of operation:

1. Inspect tires regularly and remove embedded objects immediately.
2. Check that the tires remain centered on the wheels.
3. Lubricate the truck according to the schedule provided in Chapter 1, page 1-8; however, avoid over lubrication.
4. Keep runways clean and maintain floors in good repair, free from breaks, ruts, cracks and debris.
5. Avoid excessive heat, overloading and standing loads.
6. Regularly check axle alignment and steering.
7. Avoid sharp turns and quick starts and stops.
8. Avoid oil, grease, gasoline and acid. Wipe these compounds off as soon as possible.
9. Do not allow hydraulic oil to drip onto the tires.

Checking Steer Wheels

1. First, review "Before You Begin," beginning on page 1-1.
2. With the truck raised and supported, spin each wheel and check for noise, rolling resistance and free play.
3. Rock the wheel in and out on the spindle. If there is any noticeable movement, the bearings should be checked and then repacked with grease and/or replaced.

NOTE

- *The truck is equipped with tires of a size and hardness that provide the necessary traction, and still maintain a proper shape to minimize tipping. To maintain stability and maximum reliability, you must always replace tires with the type originally supplied.*
- *It is also recommended to replace worn tires in pairs. Treaded drive tires must be replaced when the tread depth is less than 0.0625" (1.6mm) at the deepest point.*

Brake System Overview

NOTE

Braking of the Bendi 55 AC truck is accomplished by using the drive motors for restraining the truck, or by putting pressure on the brake pedal. When the accelerator is released, the moving motion of the truck is restrained by the drive motors, this occurs in both the forward and reverse direction. Stopping the truck can also be done by the normal pressing of the brake pedal.

Check Service Disc Brakes

- The service brakes are hydraulically-actuated, disc brakes, similar to an automotive disc brake system. The brake calipers are installed to the gear box / motor assembly, on the two rear drive wheels only.
- The brakes should be checked every 100 hours of operation. Normal brake pad life should reach approximately 3,000 hours of operation, but that figure can vary widely as determined by the operator and driving conditions. If you are near or beyond this time frame, you must inspect the brakes.
- New brake pads are approximately 0.265" (6.7 mm) thick. Replace them when the pad thickness is 0.0625" (1.588 mm) or less.

NOTE

A few indications of possible brake pad replacement are:

- Excess travel of the service brake pedal.
- The truck pulling to one side when the brakes are applied.
- Squealing is heard when you apply the brakes.
- Drive the truck at creep speed and apply brakes lightly, to determine if brakes pads are contacting the disk (rotor). You should feel a slight pulsating effect as the pads contact the disk.
- If any of the above occurs during brake inspection, see "Brake System," beginning on page 3-9.
- The service brake pedal must also have about 1/2" (12.7 mm) of the travel remaining when the brakes are fully applied. If less than 1/2" (12.7 mm) is available, check the pads for wear and replace as needed.

To Check the Brakes

The brakes are located in the rear of the truck attached to the drive motors.

1. First, review "Before You Begin," on page 1-1.
2. Set the Keyswitch to OFF and remove the key from the Keyswitch.
3. Place blocks in front of and behind all other wheels not being serviced.
4. Perform a Lock Out/Tag Out procedure and disconnect the battery.
5. Remove the battery.
6. Remove the battery tray to expose the brake assembly. See Figure 3-3.
7. Remove the 3/8"-24 X 1-1/2" hex headed cap screws securing the brake caliper assemble to the mounting plate. Capture the spacers (if used) and keep any shims separate for each side.
8. Check the rotor for scoring, caused by excessively worn brake pads.
9. Check the pad thickness using a 6" scale or micrometer (if the pads are removed). New brake pads are approximately 0.265" (6.7 mm) thick. If the pads are 0.0625" (1.588 mm) or less at the thinnest point they must be replaced.
10. If replacement is needed, always replace pads on both sides of the truck. Also see "Changing Brake Pads," on page 3-10.
11. Check brake lines for leaks, Repair leaks immediately.

Parking Brake Lever

NOTE

The amount of travel of the parking brake lever should allow the lever to move from the released position to the brake position. Having the brake should be fully applied before the handle travel is at its maximum.



Adjusting the parking brake lever too tight will overheat brake rotors causing premature wear; or overheat the drive motors, causing failure.

Checking Parking Brake Adjustment

1. Set the Keyswitch to OFF, then remove the key from the Keyswitch and disconnect the battery.
2. Block all wheels.
3. Raise the right side of the truck until the rear drive tire clears the floor by no more than 1" (25.4 mm).
4. While sitting on the seat, pull on the parking brake lever as far as possible using moderate force. The lever should apply pressure on the right rotor before the handle moves to the rear most position. The right rear wheel should not turn when turning by hand.



Wear work gloves before reaching into turn the wheel and allow the truck to cool. Various parts can get extremely hot during operation.

5. Release the parking brake by pulling the lever toward the front of the truck.
6. Brake adjustments are done at the rotor. No adjustments are necessary at the lever.

IMPORTANT

Do not overtighten. You will separate the cable from the clevis ends.

7. Apply and release the parking brake five or six times to stretch (seat) the cable, then double check your adjustment.
8. If this fails to properly adjust the park brake, see "Adjusting Parking Brake Caliper", page 3-15.

Parking Brake Switch

The parking brake switch electrically disables the truck when applied and is connected to the park brake handle.

Checking Parking Brake Switch

1. Set the Keyswitch to OFF and remove the key from the Keyswitch.
2. Disconnect the battery.
3. Make sure all the other wheels are securely blocked so that the truck cannot move.
4. Remove the hydraulic control valve cover.
5. Disconnect e-brake cutout switch connector.
6. Connect the ohm meter leads to the switch wires.



Figure 2-2: Ohmmeter Connections

NOTE

The meter should show less than 1 ohm.

7. Slowly pull back on the brake lever, the meter reading must be "OPEN", indicating the switch is released before the lever reaches its full locking position.

IMPORTANT

If the meter does not read "OPEN", the switch needs to be replaced (See "Replacing Parking Brake Switch" on page 3-14).

8. Disconnect the ohm meter.
9. Reassemble in reverse order.

Check Master Cylinder Fluid Level

The master cylinder is located under the driver's left compartment floor plate.

1. Remove the left floor plate. See page 3-33.
2. First clean the reservoir cap to avoid fluid contamination, then remove the fill cap and rubber gasket.
3. Additional fluid is needed when the fluid level is below the FULL line stamped in the master cylinder housing body.
4. Add fluid as needed. DO NOT OVER FILL. Use only DOT3 brake fluid from a clean, sealed source.

5. Reinstall the reservoir fill cap and rubber gasket. Tighten only enough to provide a leak-proof seal.
6. Note: Do not overtighten. This could crimp, split, or damage the seal.

Traction Drive Assemblies

Inspecting the Drive Assembly

NOTE

The Bendi 55 AC truck has an individual motor that drives each wheel.

Before attempting to replace any part of the drive units, visually inspect the following components:

- Check for leaks.
- Check all fluid levels.
- Check for loose, worn or frayed electrical cables.
- Check tires for gouges, cupping, flat spots and excessive wear.
- Check for any loose bolts or fittings.

Steering Actuator Maintenance

IMPORTANT

The steering actuator is a sealed unit. Maintenance/repair is not possible on internal components. External parts are serviceable.

Maintain the hydraulic system, and associated components, as required by the various checklists beginning on page 2-2.



CAUTION

Do not allow:

- Hydraulic fluid level to drop significantly or allow the reservoir to run dry. This will induce air into the system and cause damage to hydraulic system components.
- Prevent dirt or other foreign matter from entering the hydraulic system; clean filler caps before checking oil level.

Hoses and Tube lines: Check for cracks, hardening, or other signs of wear. Reroute any usable hoses that are kinked, severely bent, or rest against hot parts. Look for leaks, especially at couplings and fittings. Replace any hoses or tube lines that do not meet system flow and pressure ratings.

Hydraulic Fluid: Check fluid level and look for air bubbles. Check the filter. See page 1-8 for specifications on recommended lubricants.

Other Hydraulic System Components: Visually check other components to see if they are loosely mounted, show signs of leaks, or other damage or wear to the hydraulics.

NOTE

The hydraulic pump in your Bendi truck is powered by an AC non-serviceable motor. The pump supplies hydraulic pressure for steering and mast lift.

 **CAUTION**

After prolonged truck use, hydraulic oil will become hot and can burn skin. Allow hydraulic oil to cool to a tolerable temperature before performing this procedure.



Figure 2-3: Hydraulic Dipstick

Check Hydraulic Oil Level

1. Lower the mast to within a few inches of the ground, then tilt it back completely.
2. Side shift the mast to the far right and return it to the straight forward position (normal carry position).
3. With the Keyswitch OFF, turn the steering wheel left and right until it becomes difficult to turn.
4. The fill/dipstick cap is located under the left floor plate. Remove the left floor plate.
5. First clean the area around the dipstick, then pull dipstick out and wipe clean. Reinsert and then check dipstick to determine oil level.

IMPORTANT

- It is important that the proper level of oil be maintained at all times. Failure to check the oil level as recommended could cause serious mast function operating problems.
 - The oil level indicated on the dipstick is most accurate when the oil is at operating temperature of 130°F to 176°F (53°C to 93°C).
 - Do not overfill. Having the level above the FULL line does not allow enough area for expansion when the oil heats during normal operation.
6. Remove the dipstick again, holding the dipstick tip level and check the oil level. If the oil level is at the FULL line or between the FULL and ADD lines, the level is correct and no oil is needed. If the oil is at or below the ADD line, you will need to add oil to bring it up to the FULL line (maximum).
 7. Add hydraulic oil as needed. See page 1-8 for recommended lubricants.
 8. If the fluid appears very dirty or dark in color, check the truck's maintenance log for the last fluid and filter change and service it accordingly.
 9. Install dipstick, making sure it is seated. Replace the left floor plate.

Checking and Adjusting Hydraulic Pressure

 **WARNING**

HIGH PRESSURE FLUIDS CAN BE DANGEROUS! Before continuing with this section, read about the warnings of pressurized hydraulic oil under "Hydraulic System" on page 1-4.

NOTE

For ease of checking hydraulic pressure, Landoll offers a Pressure Check Kit (P.N. 0018152) which includes a 5000 p.s.i. (344.7 bar) gauge, hose and a quick-coupler assembly. If you are using your own system, have shop rags, oil absorbent and a small container ready to collect any oil spills.

1. For this test, make sure that the hydraulic tank has plenty of oil.
2. Set the key to OFF, remove the key from the Keyswitch and disconnect the battery.
3. Perform the Lock Out/Tag Out procedure.
4. Remove the control valve cover, located to the right of the driver's seat.

PLANNED INSPECTIONS

5. Operate the function levers briefly to relieve any system pressure.
6. Connect the pressure check kit quick-coupler (female end) to the test port coupler (male end) on the control valve. See Figure 2-4.
 - If you are not using the pressure check kit, remove the quick-coupler and install an appropriate fitting to accept your pressure gauge arrangement.
 - Have rags handy to collect any oil leakage.
 - Install your 5000 psi (344.7 bar) gauge arrangement to the tee fitting.
 - All parts connected to the gauge port must be capable of handling up to 5000 p.s.i. (344.7 bar).
 - To adjust pressure, the truck (pump) must be running to create hydraulic pressure. Always pay careful attention when servicing while the truck is running. To check or set the pressure, you must pull the tilt lever to dead head the cylinder to build pressure, then set the relief valve.
7. Loosen the relief valve jam nut.
8. Turn the truck on.
9. Adjust the valve stem by turning clockwise to increase pressure, counterclockwise to decrease pressure.
10. Release the joystick immediately, once the pressure is set at 1,900 psi. (131 bar)

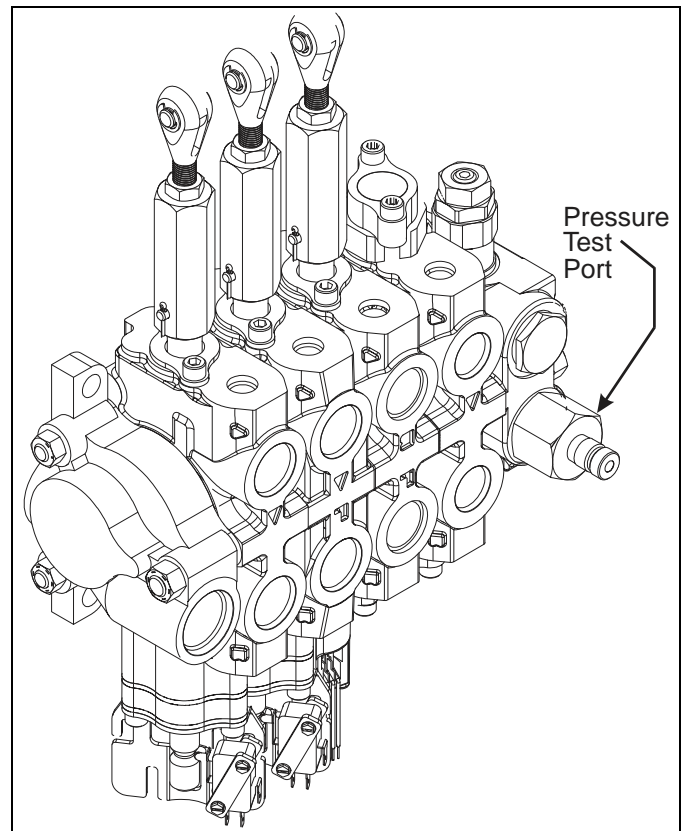

Figure 2-4: Hydraulic Pressure Test

IMPORTANT

Do not hold a hydraulic control (bottomed out) for excessive periods of time. Extreme pressure is applied to the system which can, over periods of time, generate heat, damage oil, and internal components. If the pressure is low and cannot be adjusted to the proper value, check the pump and make sure there are no leaks in the hydraulic system. If the pressure is too high and cannot be adjusted to the proper pressure, replace the relief valve.

11. Tighten the relief valve lock nut.
12. Set the key to OFF, remove the key from the Keyswitch, and disconnect the battery.
13. Operate the function controls momentarily to relieve system pressure.
14. Remove the pressure gauge quick-coupler or remove your gauge arrangement.
15. Turn the truck on.
16. Lift and lower the mast a few times to check truck operation and check the hydraulic system for leaks.
17. Set the key to OFF and disconnect the battery.
18. Reassemble all covers and panels that were previously removed.

Check Power Steering

1. Sit in the driver's seat and set the Keyswitch to ON.
2. While applying the service brake, release the parking brake and set the direction control lever to FORWARD or REVERSE. The power steering pump motor should start running.
3. If the motor does not start, first check that the parking brake is released.
4. While moving forward or backward slowly (to avoid flat-spotting), verify that the truck turns left and right with a relatively smooth, easy motion.
5. While moving forward or backward slowly, turn the steering wheel completely to the right (a full right-hand turn).
6. While moving slowly in either direction, turn the steering wheel completely to the left (counterclockwise) while counting the number of full revolutions. The steering wheel must complete approximately seven to nine revolutions, lock-to-lock.
7. Next, turn the steering wheel completely to the right (clockwise) while counting the number of revolutions. The steering wheel must complete approximately seven to nine revolutions, $\pm 1/2$ revolution, lock-to-lock.
8. Sit in the truck without touching the steering, set the direction switch to neutral, and check that the pump turns off.

Checking Steer Pressure

1. First, review "Before You Begin," on page 1-1.
2. Set the Keyswitch to OFF, remove the key from the Keyswitch.
3. Perform the Lock Out/Tag Out procedure.
4. Remove the floor plates. See "Floor Plate Removal," page 3-33.
5. For ease in checking pressure Landoll Service offers a Pressure Check Kit (p/n: 0018152) which includes a 5,000 psi (344.7 bar) pressure gauge, hose and quick-coupler. Have shop rags and a small container available to collect any oil spills. See Figure 2-5 on page 2-17.
6. Turn the steering wheel briefly from one side to the other to relieve system pressure - allow oil to drain.
7. Connect the pressure check kit quick-coupler (female end) to the coupler (male end) on the pressure test port.

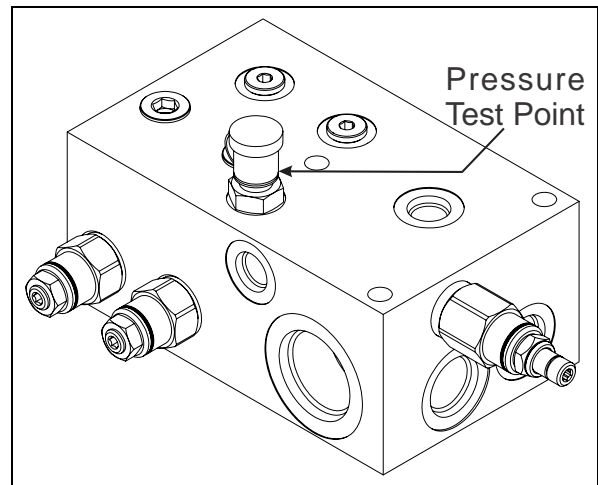

Figure 2-5: Steer Pressure Test

- If you are not using the pressure check kit, remove the quick-coupler and install an appropriate fitting to accept your pressure gauge arrangement.
 - Be prepared to collect the oil leakage.
 - Install your 3,000 psi (207 bar) pressure gauge arrangement to the fitting. Landoll recommends a 5000PSI gauge for accuracy, 3000PSI minimum.
8. Turn the truck on.



CAUTION

To check pressure, the truck and therefore the pump, must be running to create hydraulic pressure. Always use extreme caution when servicing the truck while it is running.

9. Turn the steering wheel fully to the right and hold the wheel to allow pressure buildup. The pressure reading must be 1,900 psi, ± 100 psi (131 bar, ± 7 bar) maximum.
10. Release the steering wheel.



CAUTION

Do not turn and hold the steering wheel against the rotation limit for long periods of time. Excessive pressure is applied to the circuit which can, over long periods of time, generate heat and damage internal components. If the pressure is low, check the pump and make sure there are no leaks in the hydraulic system. If the pressure is too high or too low, replace the relief valve.

11. Turn the steering wheel from one side to the other, to check the hydraulic connections for leaks.

PLANNED INSPECTIONS

12. Check for a pressure reading of 1,900 psi \pm 100 psi (131 bar, \pm 7 bar) maximum and then set the Keyswitch to OFF.
13. Turn steering wheel to release pressure.
14. Remove pressure gauge.
15. Replace relief valve if pressure reading is out of specifications.
16. Reassemble in reverse order.

Check Hydraulic Functions

1. Position the truck on a level, flat surface. Clear area around the truck.
2. Turn the Keyswitch to the ON position.
3. Make sure your right foot is on the floor of the operator's compartment and prepared to brake.
4. Pull either control lever to see if hydraulics are working. The pump must turn OFF immediately as you release the control lever.
5. If the pump keeps running, see "Hydraulic Control Valve Assembly" on page 3-18.
6. Visually check cylinders, valves, and hoses for leaks or other signs of wear.
7. Check hydraulic fluid level.

Check Side Shift Circuit Performance

1. Side shift completely to the left and hold the control handle in this position for 5 seconds. Check for external leaks at the cylinder, fittings, and hoses.
2. Side shift completely to the right and hold the control handle in this position for 5 seconds. Check for external leaks at the cylinder, fittings, and hoses.



CAUTION

- Before you remove any hoses or tubes, relieve hydraulic system pressure. With the truck off, operate the truck controls several times in both directions.
- Check for hydraulic fluid leaks using a piece of cardboard or wood. Do not use your bare hands.
- Remember to wear safety glasses.



DANGER

Hydraulic oil can be under very high pressure. A pinhole leak is not easily seen and if it pierces your skin, can cause injury and possible death.

Electrical Contactors



CAUTION

Before any maintenance or work is performed on the electrical system of the truck, perform a Lock Out/Tag Out procedure, disconnect the battery, raise the truck and put blocks on the underside of the truck

Inspecting the Contacts

NOTE

Contactors are set at the factory and should not require any adjustment. During the life of the contactor, they may become discolored, blacken or corroded. Cleaning or maintenance is not necessary. Replacement is recommended instead of maintenance. If one contactor is due for replacement, it is recommended that they are all replaced as a set.

Checking Batteries

NOTE

The electrolyte fluid level of the battery should be checked after each charge of the battery. The optimum level of the electrolyte should be about 1/2" (13 mm) over the top of the plates or just below the lip of the battery filler vent hole. If low, add distilled water OR the solution recommended by the battery manufacturer. Do not overfill.

For increased battery life reference Battery Care page 1-4 and check daily the specific gravity readings. Since the water must be mixed with the electrolyte for an accurate reading, do not check the gravity readings right after adding water. Unless the electrolyte is below the top level of the plates, do not add water right before the battery is scheduled to be charged. Normal full charged specific gravity should be between 1.265 and 1.285.



WARNING

- Always assume the battery is emitting hydrogen and practice proper safety precautions.
- Do not smoke, use an open flame, or create arcs or sparks near the battery.
- Packaged with every battery are specific instructions for battery safety, care and use, plus a Material Safety Data Sheet (MSDS). Read these documents thoroughly before servicing the battery.
- Always disconnect the battery before performing any kind of service.
- Do not lay objects on the battery as they may cause a short circuit. Shorting battery terminals can release enormous amounts of energy, causing electrical shock, sparks or flame, or heating nearby components to dangerous temperatures.
- Use caution when changing battery connectors to ensure that correct polarity is maintained.
- Truck batteries contain concentrated sulfuric acid which can cause severe chemical burns. When adding water to the battery, wear rubber gloves, protective clothing and safety glasses or full-face shield. Use a plastic container or an automatic cell filler to prevent container breakage.
- Neutralize acid spills immediately with Bicarbonate of Soda mixture. If acid contacts the skin or eyes, wash with water immediately and seek medical help at once.
- Keep vent plugs in place, fully tightened and clean at all times.
- Be sure to replace and retighten any battery restraints which have been installed on the truck.

Electrical Static Discharge

IMPORTANT

- Normal precautions concerning the handling of electronic components are applicable in order to minimize the risk of damage to these devices by Electrical Static Discharge. Avoid contact with the pins of these devices and insure that when they are removed from a printed circuit board (PCB), the pins are strapped together with conductive tape. Immediately place the PCB in static-free bubble wrap or an ESD bag.
- ESD smocks over normal clothing must be worn to discharge high voltage potentials caused by friction during normal wear.
- Use a grounding wrist band to protect microprocessors and all electronic components from static electricity and always touch a metal surface (other than the truck) before touching a PCB. These precautions are especially necessary with respect to microprocessor devices, found on the hydraulic control PCB's of this truck.

ESD Strap

Shown below is the ESD (Electrical Static Discharge) Strap which will be installed just behind the front steering assembly. See Figure 2-6. This device will drain all static electricity build up that may occur on the Bendi 55 AC forklift.

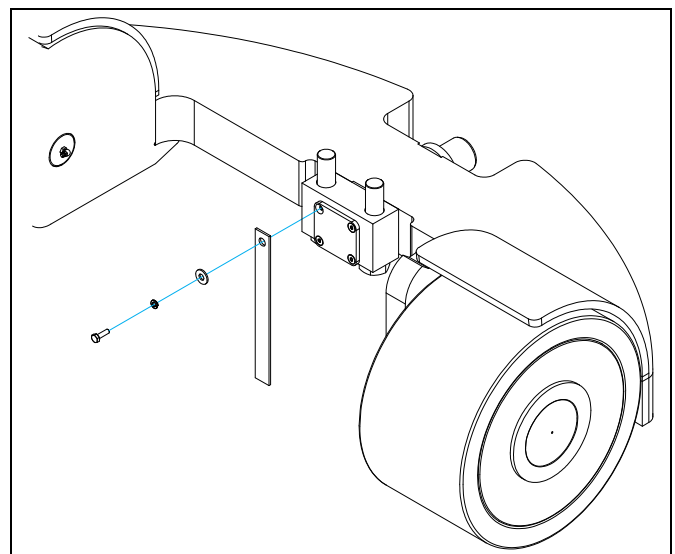

Figure 2-6: ESD Strap Location

Check the Return-to-Neutral

1. Sit in the driver's seat, and turn the Keyswitch ON.
2. Set the direction control lever to FORWARD.

PLANNED INSPECTIONS

3. Slowly move the truck forward, then slowly lift yourself off the seat, the truck should come to a stop.
4. Turn the Keyswitch OFF, then back on again.
5. Press on the accelerator pedal.
6. The truck must not move.
7. If the truck does not move, take your foot off the accelerator pedal. Place the directional control lever in NEUTRAL then back to FORWARD again.
8. Slowly push on the accelerator pedal. The truck should move forward. If it does not move, Refer to Programming Troubleshooting Chart and 1314 Monitoring Function starting at page 4-1.
9. Repeat preceding Steps 1 through 6, but instead of turning the Keyswitch OFF in Step 4, lift yourself from the driver's seat for 5 seconds to allow the switch interlock to release. The truck must react as stated in Steps 4 through 8.

Check Driver's Seat Switch

This procedure checks the physical mechanics (actuation) of the driver's seat switch only. The switch is part of the seat.

1. Start the truck and release the parking brake.
2. The seat switch and actuator are internal to the seat cushion, located on the under side of the seat cushion between the cushion and the bottom plate.
3. Set the direction control lever in either FORWARD or REVERSE and slowly apply acceleration. As the truck begins to slowly move in either direction, lift yourself from the driver's seat just enough to release the switch in the seat cushion.
4. The truck will not come to an immediate stop. You should lose forward direction (or reverse). The truck will coast unless you use you brakes.
5. If the truck continues, see "Seat Switch," page 3-38 or refer to "Curtis Controller Troubleshooting" starting on page 4-45.

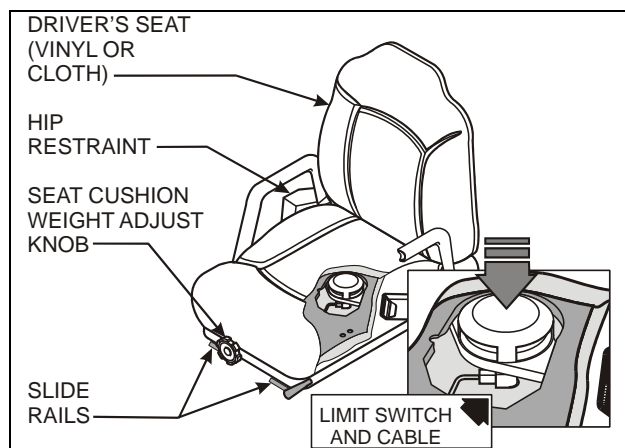

Figure 2-7: Seat Switch Assembly

Troubleshooting & Corrective Maintenance

Troubleshooting Charts

This chapter contains troubleshooting procedures to help diagnose and resolve problems.

Once the problem is located you must refer to the Corrective Maintenance Section starting on page 3-7, for repair instructions.

Troubleshooting Chart procedures are arranged as:

1. **Audible Problems**
2. **Performance Problems**
3. **Pump Problems**

Any programming problems, refer to Chapter 4, "Calibration and Programming."

Condition	Cause	Suggested Repair
AUDIBLE PROBLEMS		
Back up alarm does not sound.	Faulty alarm module. Electrical problem-frayed or broken wires, faulty direction control switch or electronics.	<ul style="list-style-type: none"> • Continuity check alarm module-replace as needed. • Check related wire harnesses and connectors for contact problems, broken wires, etc. • Examine cable assemblies - tight connections. • Wire terminal crimps should be secure and wire stranding must not be frayed or corroded.
Unusual noise when truck is in motion.	Rubbing or binding brake pads in rear wheels (possible frozen caliper). Faulty gear box assembly.	<ul style="list-style-type: none"> • Attempt to isolate cause of noise. • Drive truck slowly having another operator check for the unusual noise. • Step on brakes lightly to see if brakes are binding or rubbing excessively - repair or replace. • Replace if defective.
Singing noise.	Insufficient fluid level in gearbox. Faulty motor bearing.	<ul style="list-style-type: none"> • Check fluid level. Check and add lubricating oil as needed. • Repair or replace bearing or motor.
Muffled grinding noise.	Faulty wheel bearings - could be insufficient fluid or high pre-stress or excessive play on bearings. Damaged planetary step gearing - could be insufficient fluid, excessive play in bearing.	<ul style="list-style-type: none"> • Determine if noise is in the front or rear. • Dismount gear box and examine for damage.
Clicking noise during a turn.	Loose or shifting component.	<ul style="list-style-type: none"> • Try to isolate the area of the noise, then check for loose parts, misalignment, load shifting, etc. • Check that components are in place and properly torqued.

TROUBLESHOOTING & CORRECTIVE MAINTENANCE

Condition	Cause	Suggested Repair
Horn does not work.	<p>Faulty horn assembly or push button.</p> <p>Blown fuse.</p>	<ul style="list-style-type: none"> • Disconnect horn wires and push button - continuity test horn with leads connected to battery power. • Check related wire harnesses and connectors for contact problems, broken wires, etc. • Examine cable assemblies for tight connections. • Wire terminal crimps should be secure and wire stranding must not be frayed or corroded. • Check fuse. • Check for electrical shorts in wiring or components.
Rubbing noise from the front wheels.	Faulty wheel bearing or damaged wheel shaft.	<ul style="list-style-type: none"> • Dismount suspected wheel and examine bearings and shaft. • Check for foreign material lodged inside wheel hub - remove and repair and/or replace as needed.
Scraping noise when the mast is operated	Out of alignment. Faulty hydraulic cylinder - lift, tilt and/or shift.	<ul style="list-style-type: none"> • Realign and shim mast rails accordingly. Determine which cylinder is bad-rebuild or replace. (Seal kits are available for repair)
PERFORMANCE PROBLEMS		
No operation	<p>Battery disconnected or insufficient charge.</p> <p>Emergency STOP (disconnect) push button is pressed.</p> <p>Improper start-up sequence.</p> <p>Blown fuse.</p> <p>Bad Keyswitch</p>	<ul style="list-style-type: none"> • Make sure battery installed is a 48 VDC battery. • Check battery for connection. • Check battery for full charge. • Check push button and if necessary, release push button. • Place the direction switch in NEUTRAL before power on. • Remember to wait about ten (10) seconds after power on to allow diagnostic testing. • Check main power fuses (425 Amp). • Check for electrical short, or electrical connections. • Check keyswitch fuse • Possible faulty horn - check horn.
Poor truck performance.	<p>Battery undersized.</p> <p>Undercharged battery.</p> <p>Excessive electrolyte loss.</p>	<ul style="list-style-type: none"> • Refer to capacity plate for battery rating and install battery with proper ratings. • Return truck to charging station and check battery characteristics. • Adjust specific gravity at state of full charge.
Service brakes do not stop the truck.	<p>Low fluid level in master cylinder reservoir.</p> <p>Worn brake pads.</p> <p>Brake pedal linkage adjustment.</p> <p>Brake pad contamination.</p>	<ul style="list-style-type: none"> • If low, check for leaking fittings or lines - tighten and/or replace. Add brake fluid and bleed brakes if needed. • Also check wheel calipers for leaks -rebuild or replace. • Check brake pads for wear or defects -always replace both sides. • Check linkage for loose nuts, broken or stressed linkage, mis-adjustment - repair and re-adjust. Reference "Service Brake Linkage" on page 3-29. • If the pads are saturated, they must be replaced.

Condition	Cause	Suggested Repair
<p>Spongy or soft service brake pedal.</p>	<p>Possible air in brake lines.</p> <p>Faulty master cylinder.</p> <p>Faulty brake caliper.</p>	<ul style="list-style-type: none"> • Bleed air from brake lines - indicated by bubbles in fluid during fluid bleed, or when checking the master fluid reservoir. • Check brake system for loose fittings, cross threaded fittings and brake calipers for leaks. • Also check master cylinder reservoir fluid level - low level can allow air into lines. • Examine the brake lines, wheel calipers and master cylinder for leaks - repair immediately, then bleed the brakes. • Also check master cylinder piston for worn seals. Reference "Master Cylinder" on page 3-31. • Remove the master cylinder filler cap and "slowly" press the brake pedal. A pulse of fluid should be seen in the cylinder reservoir. If not, replace the cylinder. • Check brake caliper for leaks - rebuild or replace.
<p>Parking brake does not hold the truck.</p>	<p>Brake cable system malfunction or out of adjustment.</p>	<ul style="list-style-type: none"> • Check parking brake linkage for loose nuts, broken or stressed linkage, mis-adjustment - repair and readjust. See page 3-14.
<p>Steering drifts/wanders or is erratic.</p>	<p>Improperly sized tires.</p> <p>Low fluid or leaks in power steering system.</p> <p>Worn or out-of-adjustment steer assembly.</p> <p>Insufficient hydraulic pressure.</p> <p>Steering potentiometer misaligned.</p> <p>Worn, loose wheel bearings.</p> <p>Air in the hydraulic system.</p>	<ul style="list-style-type: none"> • Check Identification plate for proper fit and replace if not proper size • Check hydraulic fluid level -replenish as necessary. • Check all related components for seal or fitting leaks - repair or replace. • Check motion control valve cartridges for foreign material (these are replaceable cartridges and will wear out over time). • Failed or weak orbital centering spring will cause the steering to drift - replace accordingly. • Check to see if the actuator's compression coupling is properly torqued to 30 ft/lbs (40.6 Nm). • Air may have gotten into the system. Bleed actuator lines. • Replace worn actuator. • Check hydraulic pressure of steering relief valve (1,900 psi). • Check actuator for internal or seal leaks, sticking or mis-adjustment - repair or replace. • Perform dash calibration. • Check wheel bearings - replace as needed. • Check the inlet connections to determine where air is being drawn into the system. • Internal leaks? Tighten loose connections. • Bleed hydraulic system.

TROUBLESHOOTING & CORRECTIVE MAINTENANCE

Condition	Cause	Suggested Repair
Hard steering effort in one or both directions.	<p>Improperly sized tires.</p> <p>Vehicle overloaded.</p> <p>Low hydraulic fluid.</p> <p>No and/or low flow rate or fluid pressure.</p> <p>Components in steering linkage binding or making noise.</p> <p>Drive tires scrubbing.</p>	<ul style="list-style-type: none"> Inspect/correct tire size. Vehicle overloaded. NEVER exceed capacity of the truck. Check capacity nameplate for tire specs. Never exceed vehicle capacity. Low hydraulic fluid. Check/fill hydraulic oil level, Low flow rate or fluid pressure. Restriction in fluid return line. Remove line, clean and/or replace line. Check pump and priority valve. Check hydraulic pressure - 2,600 psi. Check for steering column, orbital, front rotation bearing noise. Check steer pot settings. Adjust or replace.
Lost motion at the steering wheel.	<p>Steering wheel loose on column or stripped.</p> <p>Air in the hydraulic system.</p> <p>Internal Hydraulic Leak</p>	<ul style="list-style-type: none"> Check and re-torque the steering wheel locking nut. Check the inlet connections to determine where air is being drawn into the system. Tighten loose connections. Check the minimum drive speed which may be too slow to prime the pump. Bleed hydraulic system. Repair and check hydraulic steer components.
Truck does not turn.	<p>Hydraulic pump not activated.</p>	<ul style="list-style-type: none"> Check that the hydraulic pump/motor is activated when the operator is on the seat and the direction is selected.
Truck moves slowly.	<p>Battery may be too low.</p> <p>Traction motor encoder error.</p> <p>Faulty accelerator switch module.</p> <p>Overheated motor or motor controller (thermal cutback).</p> <p>Truck has gone into LOS Mode "Loss Of Sensor" also known as "Limp Home Mode"</p>	<ul style="list-style-type: none"> Check battery charge state and recharge battery, if necessary. A discharged battery reduces effective voltage across the traction motors and control circuits. Slow travel speeds and erratic contactor operation may result. Verify encoder is operational. Replace accelerator switch module. If overheating is suspected, turn OFF the truck, and allow time for the system to cool. While the truck is cooling, check the following: Check motor compartment cooling fan to ensure they are operating and clean. Look at dash display to check for errors. Record fault code to determine problem - Refer to page 4-46, Program Troubleshooting Chart definitions.
Truck does not move.	<p>Battery charge state may be too low.</p> <p>System fault is present.</p> <p>Faulty direction control lever.</p> <p>Faulty accelerator switch assembly.</p> <p>Open armature on traction motor.</p>	<ul style="list-style-type: none"> Check battery charge state & recharge battery if necessary. Check dash display for fault condition. Refer to controller troubleshooting if fault is present. See page 4-46. Check that the direction control forward-neutral-reverse control is functioning properly. Repair accelerator switch. Repair or replace.
Creep speed or acceleration sluggish.	<p>Control panel system is mis-adjusted.</p>	<ul style="list-style-type: none"> Re-adjust the control panel. Refer to Chapter 5 - Multi-Function operation.

Condition	Cause	Suggested Repair
Mast lifts slowly - loss of lift speed.	<p>Attempting to lift a load in excess of the truck's capacity.</p> <p>Faulty lift pot. Battery charge state may be too low.</p> <p>Controller output incorrect. Insufficient pump or relief valve pressure setting.</p> <p>Mechanical damage of the mast. Hydraulic cylinders leaking.</p>	<ul style="list-style-type: none"> • NEVER attempt to lift a load heavier than the specified rating of the truck. • Adjust or replace. • Check battery charge state and recharge if necessary. • Check settings. • Check settings. • Repair or replace. • Repair or replace.
Mast drifts downward.	<p>Excessive load - attempting to lift loads beyond the capacity of the truck.</p> <p>Lift hydraulic cylinders leaking or binding.</p> <p>Faulty lift control valve.</p> <p>Piston check valve leaking.</p>	<ul style="list-style-type: none"> • Never exceed truck lift ratings. • Oil may be bypassing between the spool and body - repair or replace directional control valve. • The spool is not centering properly or is broken - repair or replace lift control valve. • Check Chapter 5, for vendor service information, where applicable. • Replace check valve.
Mast does not lift load.	<p>Attempting to lift a load in excess of the truck's capacity. Faulty lift pot.</p> <p>Battery charge state may be low.</p> <p>Low hydraulic oil.</p> <p>Faulty hydraulic control valve.</p> <p>Insufficient system pressure.</p> <p>Faulty pump. Note: If the pump were faulty, other mast functions would also be affected. Blown fuse. Mechanical mast damage.</p>	<ul style="list-style-type: none"> • NEVER attempt to lift a load heavier than the specified rating of the truck. • Replace lift pot. • Check battery charge state & recharge battery if necessary. • Low levels can cause the pump to "cavitate" and not permit full lift of the mast. Add hydraulic oil. • Bent or damage plunger, worn internal seals - repair or replace as needed. • Check hydraulic pressure of system relief valve. Try re-adjusting the pressure relief valve. Maximum system pressure must not exceed 2,800 psi. See page 3-18. • Check valves for seal leaks, sticking or misadjustment. • Repair or replace and/or readjust accordingly. • If problem persists, replace the relief valve cartridge. • Check settings. • Replace the pump. • Determine which cylinder is leaking or binding - rebuild or replace. Seal kits are available. • Check lift pump control fuse. • Check mast for damage and signs of misadjustment.

TROUBLESHOOTING & CORRECTIVE MAINTENANCE

Condition	Cause	Suggested Repair
<p>Mast does not tilt.</p>	<p>Inoperative tilt directional control valve. Faulty switch.</p> <p>Insufficient pump or relief valve pressure.</p> <p>Restricted or leaking supply hoses. Hydraulic cylinder leaking or binding.</p> <p>Controller output incorrect.</p>	<ul style="list-style-type: none"> • Repair or replace. • Continuity test switch. Replace if defective. • Check settings. • Adjust pressure. • Follow recommended maintenance schedule. • Check Chapter 7, for vendor service information, where applicable. • Locate restriction or replace hose. Tighten fittings to seal any leaks. • Shift cylinder is leaking or binding-rebuild or replace. Seal kits are available for most cylinders. • Check settings via the 1314 software program in Chapter 5 Calibration and Programming, starting on page 4-1.
PUMP PROBLEMS		
<p>No hydraulic pressure.</p>	<p>Pump driven in the wrong direction of rotation <i>after</i> servicing.</p> <p>Coupling or shaft sheared or disengaged. Oil intake line is restricted.</p> <p>Fluid viscosity too heavy to pick up prime.</p>	<ul style="list-style-type: none"> • Change the drive direction immediately to prevent seizure. • Correct the pump cartridge ring position for each direction of rotation. • Disassemble the pump and check the shaft and cartridge for damage. • Check all strainers and filters for dirt and sludge - clean or replace. • Completely drain the system. • Add new filtered oil of the proper viscosity.
<p>Leaking fluid.</p>	<p>Cracked or cut hoses.</p> <p>Loose or faulty hose clamps. Loose or faulty hydraulic fittings. Oil seals deteriorated.</p>	<ul style="list-style-type: none"> • Replace. NEVER attempt to patch a hose. • Tighten and/or replace. • Tighten and/or replace. Be careful not to strip the threads, rendering the fitting defective. • Disassemble the unit and replace the oil seals.
<p>Pump making noise.</p>	<p>Pump intake partially blocked.</p> <p>Air leaks at the intake or shaft seal. (Oil in reservoir would possibly be foamy.) Damaged pump/motor mount.</p>	<ul style="list-style-type: none"> • Service the hydraulic tank intake strainer. • Check the fluid condition and, if necessary drain and flush the Hydraulic system. Refill with clean oil. • Check intake lines (hoses and fittings) and seals for leaks. Repair all leaks. • Repair and/or replace.
<p>Significant loss of speed under load.</p>	<p>Lack of sufficient oil supply.</p> <p>High internal motor leakage. Excessive heat source.</p> <p>Severely worn or damaged internal splines.</p>	<ul style="list-style-type: none"> • Check for faulty relief valve and adjust or replace as required. • Check for and repair worn pump. • Check for correct oil • Locate excessive heat source, usually a restriction in the system, correct the condition. • Disassemble unit and replace worn rotor set, drive link and replace pump.

Corrective Maintenance

This section is divided by features. For each feature, major adjustment and/or settings, mechanical repairs and electrical control system repairs are addressed. Features are listed in the Table of Contents, at the front of this book, along with page reference information.

As a Safety Reminder - Duplicate Safety Information and Precautions from Chapter 1 are provided here.

IMPORTANT

- It is important to always locate the section that pertains to your needs, then read the entire procedure before attempting to adjust, repair and/or replace parts.
- It is recommended to always use genuine Landoll replacement parts to maintain the overall high quality performance and guarantee maximum truck stability, and to minimize downtime.

When it becomes necessary to do an electrical or mechanical service repair or maintenance procedure, it is important to have the proper tools required, in both English and Metric sizes, and to review/practice the following safety suggestions.



WARNING

- You could be injured and the truck could be damaged if you try to do service work without qualified experience.
- If you use the wrong grade replacement parts, in time, they can break or loosen and serious injury could occur.
- It is recommended to use Landoll replacement parts before you attempt any truck maintenance.

- Be sure to use the proper nuts, bolts and other fasteners. Many are specifically rated; i.e. SAE Grade 5, SAE Grade 8, ISO Prop Class 8.8, etc., and must be replaced with the identical type.
- Whenever possible, return the truck to a service area having sufficient lighting, work space and an assortment of tools needed to complete the repair.
- **Set the key switch to OFF and remove the key from the Keyswitch.**
- Set the direction control lever to NEUTRAL and set the parking brake.



CAUTION

To be certain the truck will not move, place wedges (or blocks of wood) at the front and back of the tires. If you are servicing the brakes or tires, place the block at the front and rear of the tire farthest away from the one being serviced, that is, the tire on the opposite side of the truck and at the opposite end.

- Refer to the general maintenance, safety and battery safety instructions starting on page 1-1.
- Disconnect the battery.
- Never place a tool or any metal object on top of the battery where it could possibly touch battery terminals causing a short or serious electrical shock.

Mast & Front Rotation

Side Shift Circuit Maintenance

The following information is provided for authorized service facilities ONLY. Perform maintenance on the side shift circuit as required by the recommended Checklists.

Hydraulic Steer Actuator Replacement

1. For reference, see Figure 3-1.
2. Remove the key and place in a secure area.
3. Perform the Lock Out/Tag Out procedure.
4. Disconnect the battery.
5. Release hydraulic pressure in the system by moving all control levers back and forth and turning the steering wheel left and right.
6. Remove the mast. See page 1-7.
7. Remove the front rotation cover.
8. Remove the rotation switch bracket and rotation pot from the top side of the steering gear assembly.
9. Remove 4 (if B55) or 8 (if B55HL) 7/8"-9UNCx2.25 hex socket screws to remove the front plate assembly from the truck.
10. Remove the 10 Allen socket screws from the actuator couplers (one on top, one on bottom) using a 6mm Allen drive socket and screw them into their adjacent tapped holes. This loosens the coupling, so take care to not damage the bottom coupling as it may fall to the floor.
11. Remove the hydraulic fittings and cap hoses to prevent spills.

12. While bracing the steer actuator against the front plate, remove the 4 1"-14UNFx3.25 screws and lockwashers from the front of the front plate.
13. Lift off the upper actuator mount and remove the actuator.
14. Reassemble the steering actuator in reverse order. Loosening the bleeder ports in P1 and P2 can help with rotation of the actuator. Assure that when reassembled that P1 and P2 are retightened and perpendicular to the front plate.
15. The 1"-14x3.25 and 7/8"-9x2.25 screws should be torqued according to the torque chart on page 1-8.
16. The coupling screws should be replaced in their adjacent holes and tightened a little at a time in a star pattern. Final torque should be 30 ft. lbs. (41 Nm.).
17. Re-calibrate with the Bendi B55AC truck instructions beginning on page 4-1.



Figure 3-1: Steer Actuator

NOTE

- Power steering pressure is set at 1,900 psi \pm 100 psi (131 bar, \pm 7 bar). A pressure gauge port is provided, with a "quick-coupler," (pressure service kit, Landoll p/n: 0018152) for reading the steer pump pressure when hooked to the pressure relief valve.

Before you service this valve for possible pressure problems, make sure there are no leaks in the hydraulic system and that there is sufficient oil in the tank. Both conditions can contribute to low pressure problems.

Hydraulic Steering Actuator Maintenance

The steering actuator is a sealed unit. Maintenance/repair is not possible on internal components. Only external parts are serviceable.



Figure 3-2: Actuator Ports

Actuator Seal Lubrication

1. Start the truck and turn the mast fully to the right.
2. Locate the two grease-fill ports on the front side of the actuator (where mast is when in normal carry position). See Figure 3-2.
3. Apply 2-3 pumps of the recommended grease to the top and bottom ports. (See "Lubrication Specifications" on page 1-8.)
4. Turn the mast fully to the left and apply 2-3 more pumps.
5. Repeat as necessary until the grease begins to escape from the relief fittings on the top and bottom (top area shown).



DANGER

Be cautious when turning the mast back and forth. Make sure that all personnel and obstructions are out of the way. Something may become trapped between the mast and the body of the forklift, resulting in damage, injury or death.

Brake System

IMPORTANT

- Safety must always be paramount when working on brake system components.
- Parts that are not in perfect working condition should not be used. It is recommended to only use genuine Landoll parts.
- If you are unsure about a procedure, seek professional help.
- Wear eye protection. If brake fluid comes in contact with eyes, immediately rinse with water and seek medical attention.
- Use only DOT #3 brake fluid.
- Brake fluid will damage paint. Cover all body parts and be careful not to spill brake fluid during brake maintenance.
- Brake pads must be replaced on both sides at the same time. NEVER replace the pads on only one wheel to ensure that both sides have equal braking and to prevent premature wear and uneven braking action.
- Do not use petroleum based solvents to clean brake parts. Use only brake cleaner or denatured alcohol.
- Do not use compressed air to blow particles from the brake assembly.
- Make sure you strictly adhere to all clearances and torque specifications.
- When you are finished working on the brakes, test them carefully under controlled areas before releasing truck for operation.
- If the contact surfaces of the rotor show cracks, score marks, deep grooves, a raised lip on the outer edge, or signs of overheating or warping, the rotor must be replaced.
- If a problem is suspected, do not release or drive the truck until the problem is corrected.

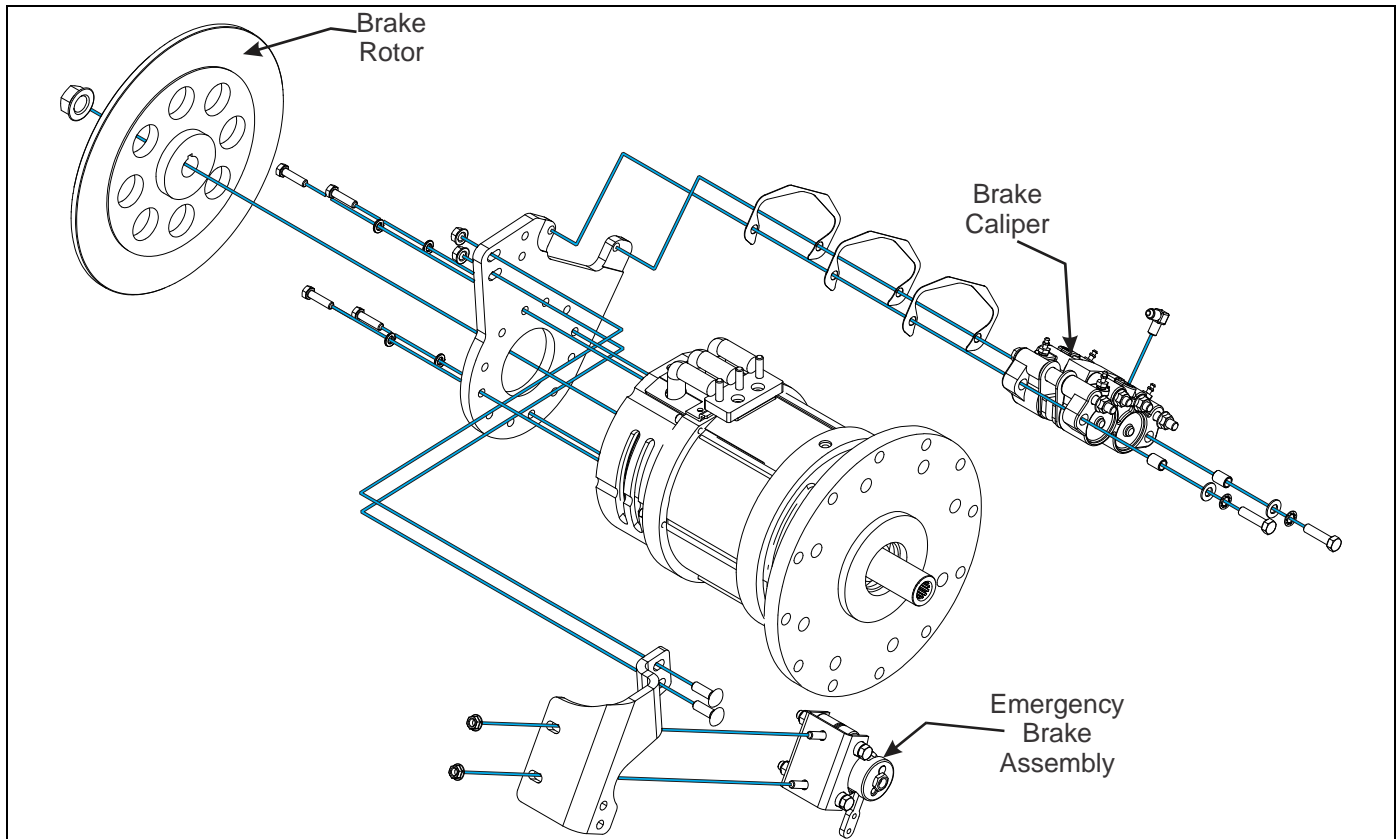

Figure 3-3: Brake Assembly

Changing Brake Pads

1. See Figures 3-3 and 3-4 for reference.
2. Set the Keyswitch to OFF and remove the key from the Keyswitch.
3. Initiate a Lock Out/Tag Out procedure.
4. Apply the parking brake and disconnect the battery.
5. Make sure all the other wheels are securely blocked so that the truck cannot move.
6. Remove the battery.
7. Remove the battery tray.
8. Remove the 3/8"-24 X 1-1/2" hex headed cap screws securing the brake caliper assemble to the mounting plate. Capture the spacers (if used) with and keep any shims separate for each side.
9. If preferred, although not necessary, disconnect the brake lines, using a flare-nut wrench. Plug or cap the ends to avoid fluid loss and contamination.
10. Be prepared to clean any brake fluid spills. **DO NOT** spill brake fluid on the caliper housing.
11. Remove the two outer hex head screws and hardware to allow pads to be removed from the caliper assembly.
12. Remove both old disk brake pads.
13. Push the piston into the caliper bore to provide clearance between the new brake pads and the rotor during assembly.
14. Check the contact surfaces of the brake rotor for cracks, score marks, deep grooves, a raised lip on the outer edge, signs of overheating or rotor run-out. If any of these are present, the rotor must be replaced.
15. Also look for the presence of surface glazing, grease or brake fluid on the brake pad contact surfaces. Grease and brake fluid can be removed using denatured alcohol or brake cleaner. However, if the pads become contaminated, they must be replaced.
16. Check the brake lines for cracking, splits or any apparent weakness. Replace as needed.
17. Check both brake caliper pistons for signs of fluid leakage, indicating a seal which must be replaced.
18. Tighten the new brake pads and reassemble the caliper (two outer hex head screws and hardware).
19. Install the brake caliper assembly to its brake caliper mount. Ensure the correct number of shims are installed between the caliper and the mount. Pads should have the same clearance from the disk prior to actuation of brakes.
20. Bleed the brakes if any brake lines have been disconnected, making sure to add new fluid.
21. Top off the master cylinder with new brake fluid. Pump the brakes several times to seat the new brake pads.

22. Reassemble and check the truck. Connect the battery and check for proper brake operation as follows:
 - Accelerate the forklift to full speed.
 - Apply the brakes to quickly STOP the wheels.
 - Release the brake pedal after the wheels stop, then accelerate again to full speed.
 - Release the accelerator pedal to allow the truck to coast to a stop.
 - Both wheels should have equal amounts of resistance.
 - Repeat this procedure two times in forward and reverse directions. If the forklift does not perform as stated above, reinspect the brake calipers for wear.
 - Make a few normal stops in forward and reverse to allow the brakes to further seat themselves. Do NOT lock the brakes which could cause tire flat spots.

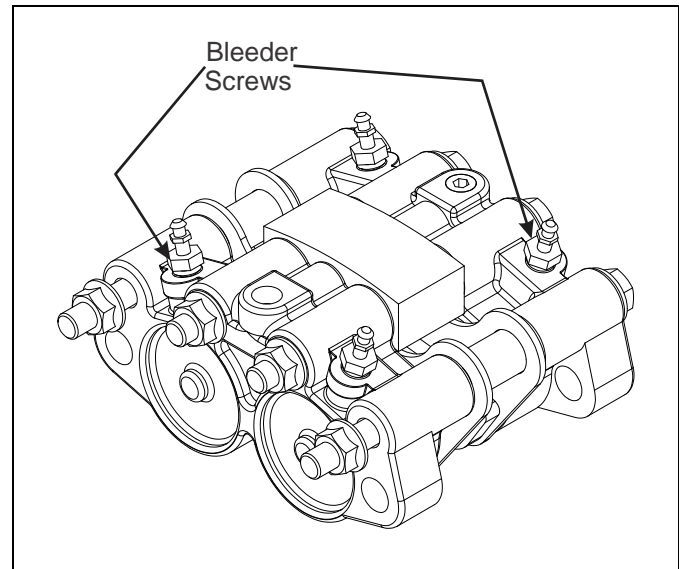

Figure 3-4: Bleeder Screws

Bleeding Brakes

NOTE

Bleeding the brake system is necessary to remove any air that is trapped when replacing brake lines, brake calipers or the master cylinder. To avoid extensive damage to the system, use only DOT 3 brake fluid.



CAUTION

Wear eye protection. If brake fluid comes in contact with your eyes, immediately rinse them with water and seek medical attention.

Check the fluid level often during the bleeding operation and add fluid as needed to prevent the level from falling low enough to allow air bubbles into the master cylinder. Use only new DOT 3 brake fluid from a sealed container. NEVER use old or used brake fluid. It contains moisture which will deteriorate the brake system components.

IMPORTANT

It is necessary to bleed both brakes to both wheels if air has entered the system. Air in the brake system can be caused by low fluid level or if a brake line has been leaking or disconnected. If the brake pedal feels spongy when pressed and travels almost to the mechanical stop but regains height when pumped, air has entered the system. The system must be bled. If no fittings were recently opened for service, check for leaks that would have allowed air into the system and repair leaks before attempting to bleed the system.

Have an assistant available, as well as a supply of brake fluid, an empty container, a length of 3/16" (4.763 mm) clear plastic or vinyl tubing to fit over the cylinder bleeder fitting and a six point wrench to open and close the fitting.

NOTICE

DO NOT allow fluids to go inside of the brake caliper and onto the brake pad. It will contaminate the brake lining and cause failure.

To bleed the brakes:

1. First, review "Before You Begin," page 1-1.
2. Set the Keyswitch to OFF and remove the key from the Keyswitch.
3. Apply the parking brake, perform a Lock Out/Tag Out procedure and disconnect the battery.
4. Lift and block the back end and remove the rear drive wheels.
5. Start with the right wheel (the wheel farthest from the master cylinder).
6. Loosen the bleeder fitting slightly, then tighten it where it is snug but can be loosened quickly and easily.

7. Fit a length of tubing over the bleed screw and immerse the other end in the container of new brake fluid. Check that the tubing fits tightly over the bleeder fitting. See Figure 3-5.
8. Check fluid level in the master cylinder. Fill before you begin.
9. Have someone slowly press on the brake pedal several times to build pressure in the system, then hold the pedal down.

IMPORTANT

Be careful when handling bleeder screws. Rust may cause the fitting to break. Spray the fitting with penetrating oil before attempting to loosen. Use a 6-sided wrench instead of a 12-sided wrench.

10. Loosen the cylinder bleed screw until fluid starts to flow. Watch for air bubbles at the immersed end of the tube.
11. When the brake pedal bottoms, tighten the bleed screw, then release the pedal. **DO NOT** release pressure on the pedal until the bleed screw is tightened.
12. Repeat Steps 8 through 11 as many times as needed until the fluid draining in the container is free of air bubbles.
13. Fill the master cylinder fluid level and add as needed before bleeding the other side.
14. Check the operation of the brakes. The pedal should feel solid when depressed, with no softness. If necessary, repeat this procedure.

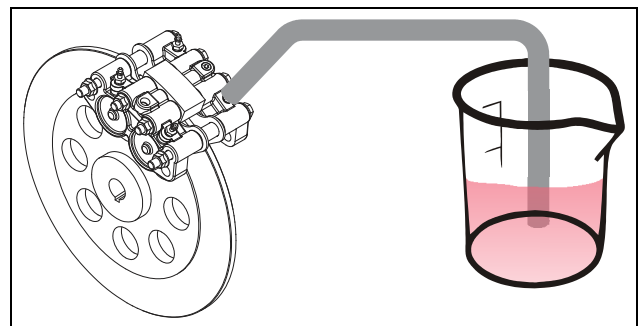

Figure 3-5: Brake Bleeding

Replacing the Brake Caliper Assembly

IMPORTANT

Whenever servicing or replacing a caliper assembly, it is recommended to service both sides of the truck to prevent premature wear and uneven braking action. Whenever a brake caliper is disconnected, it is recommended that the entire brake system be purged of old brake fluid.

1. Repeat steps 1 through 8 of section "Changing Brake Pads" on page 3-10.
2. Remove brake caliper assembly.
3. Install the new caliper assembly in reverse order making sure the brake pads are properly installed.
4. Bleed the brakes.
5. It is recommended when replacing a brake caliper assembly, you should purge the entire brake system of used, possibly contaminated fluid.

Repairing Brake Caliper Pistons

IMPORTANT

If the brake caliper piston freezes up or shows signs of leakage, it must be repaired or replaced.

Whenever servicing or replacing a caliper assembly or internal parts, you must service both sides of the truck to prevent premature wear and uneven braking action.

1. Repeat steps 1 through 8 of the section "Changing Brake Pads" on page 3-10.
2. Remove the brake caliper assembly from the truck.
3. Restrain the piston in the caliper to stop the piston, then lightly apply compressed air to the inlet port.

IMPORTANT

Do NOT apply too much air pressure to the bore, or the piston will eject and cause damage to the piston or the technician. Stand back from the piston while air is being applied.

4. Once the piston releases, remove the O-ring seals and discard. Be careful not to scratch metal surfaces. Do not use metal tools when removing the seal.
5. Remove both bleeder screws.
6. Inspect the piston and the caliper housing bore for corrosion, worn plating, scoring, nicks, etc. Crocus cloth may be used to polish out light corrosion only. If extensive corrosion exists, the entire brake caliper assembly must be replaced.

7. Thoroughly wipe out the bore area and clean all parts, lubricate the pistons, caliper and O-ring seals with fresh, DOT #3 brake fluid.
8. Install the O-ring seal to the pistons and slide the pistons into the housing bore. Make sure the O-ring seals do not twist as the piston is inserted.
9. Bottom out the piston into the bore, install new brake pads. Reinstall caliper assembly onto caliper bracket.
10. Bleed the brakes.
11. Repeat steps 19 through 20 of the section "Changing Brake Pads" on page 3-10.

Disc Brakes

The disc brakes are inherently self-adjusting. NO adjustments are necessary or provided. Refer to "Changing Brake Pads," page 3-10.

Disc Brake Rotors

IMPORTANT

- **Whenever servicing and/or replacing a rotor assembly, you must service both sides of the truck to prevent premature wear and uneven braking action.**
- **Repeat steps 1 through 6 of section "Changing Brake Pads", beginning on page 3-10.**
- **Check the rotors for scoring, cracks, deep grooves, raised lip on the outer edge, signs of overheating, rotor run-out or other damage. Rotor run-out should be measured while the rotor is installed.**
- **Rotor thickness measurements may be checked with the rotor installed or removed from the truck. Use a dial gauge to check run-out. Use a calibrated micrometer, calibrated in ten-thousandths of an inch, to check thickness. See Figure 3-6.**

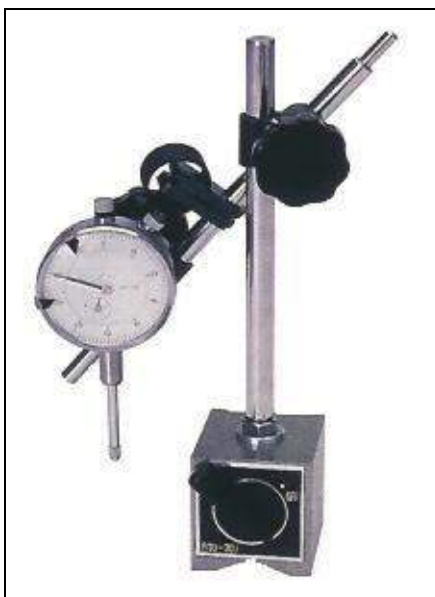

Figure 3-6: Rotor Dial Indicator

Measuring Rotor Thickness

IMPORTANT

- Measure thickness, using a micrometer, at four or more points on the rotor and make sure all measurements are taken at the same distance in from the outer edge of the rotor.
- Thickness variations of more than 0.0005" (0.013 mm) can cause pedal pulsation and/or vibration when applying the brakes. A rotor that does not meet these specifications must be replaced.

Check Lateral Run-Out (Warping)

1. Lift, jack up, and block both sides of the truck to allow the drive wheel to rotate freely, See "Lifting the Truck," page 1-6.
2. Secure the dial indicator to the drive wheel electric motor casing so the indicator button contacts the rotor at about 0.50" (13 mm) from the outer edge of the rotor. Set the dial indicator to zero.
3. SLOWLY turn the rotor (wheel/tire) by hand one or two complete revolutions and observe the total indicated run-out.
4. If the run-out exceeds 0.0031" (0.08mm), replace the rotor. Do not resurface the rotor - see "Replacing Brake Rotor Assemblies," page 3-13.

Replacing the Brake Rotor Assemblies

1. Repeat Steps 1 through 8 of "Changing Brake Pads", section on page 3-10.
2. Remove brake caliper assembly.

IMPORTANT

To remove the rotor, you will need a pry bar and a rubber mallet (dead-blow hammer). **DO NOT USE** an unprotected hammer. You will damage the rotor rendering it unserviceable.

3. Loosen the flanged hex nut (3/4-16, Grade 8) and hardware from the motor shaft. **DO NOT** remove the nut from the assembly at this time.
4. Loosen the bolts mounting holding the motor to the frame enough to move the motor out to allow a gear puller on the brake rotor. Pry bars can cause damage.
5. Using the rubber mallet (dead-blow hammer), hit the rotor on the opposite side, driving it towards the loosened nut.
6. Repeatedly hit the rotor evenly in a circular motion until it becomes free, then remove the nut.
7. Depending on the model and the amount of clearance available, you may have to remove one of the drive motors to remove the rotor from the armature.

IMPORTANT

The removal of the drive motor can be done as a completed assembly. It needs to be slid out just enough for the rotor to clear.

8. Slide the rotor assembly from the keyed drive shaft and discard. Do not lose the woodruff key.

IMPORTANT

When handling the new rotor, protect the finished surfaces from damage, such as nicks, deep scratches, dents from dropping, corrosion, oil or grease contamination, etc. Damage to the braking surfaces renders the rotor or pads defective.

9. Install the new rotor to the keyed drive shaft. Install, tighten and torque the flange hex nut to 150 Ft-lbs (203 Nm).

NOTE

Make sure there is no grease on the shaft/nut area before installing and torquing the nut.

10. Reassemble in reverse order.
11. Repeat Steps 11 through 20 of the section "Changing Brake Pads," on page 3-10.

Parking Brake Assembly

The parking brake assembly includes:

- Parking Brake Lever
- Parking Brake Switch
- Parking Brake Cable
- Parking Brake Caliper Assembly

Replacing Parking Brake Lever Assembly

1. First, review "General Maintenance Instructions," on page 1-2.
2. Set the Keyswitch to OFF, then remove the key from the Keyswitch.
3. Perform a Lock Out/Tag Out and disconnect the battery.
4. Make sure all the other wheels are securely blocked so that the truck cannot move.
5. Remove floor plates.
6. Remove lower dash cover weldment.

NOTE

The parking brake lever assembly is located to the left of the hydraulic control valves & to the right of the operator.

7. Disconnect the clevis end brake cable.
8. Replace with new parking brake lever assembly.
9. Remove brake linkage and brake switch cam from old lever assembly and install on the new lever.
10. Reassemble in reverse order.
11. Adjust park brake. Refer to page 3-15.

Replacing Parking Brake Switch

1. First, review "General Maintenance Instructions," on page 1-2.
2. Set key to OFF and place key in a secure place.
3. Apply the parking brake. Perform a Lock Out/Tag Out procedure and disconnect the battery.
4. Make sure wheels are blocked so that the truck cannot move.
5. Remove the hydraulic control valve cover.
6. Disconnect the switch at the Deutsch connector and release the jam nut on the park brake handle.
7. Remove the jumper harness, if used, from the switch and install to the new switch.
8. Install the new switch in reverse order.
9. Connect the switch at the connector.

NOTE

A pin within the handle activates the switch and has no adjustment. It is always activated in the resting position.

To check the operation of this switch:

1. Start the truck and release the parking brake.
2. Set the control lever to FORWARD and very slowly increase motor speed.
3. As the truck is moving forward at slow speed, slowly pull up on the brake lever.
4. The truck must immediately slow to a STOP.
5. If the truck continues moving forward, recheck the setting and operation of the switch.

NOTICE

DO NOT release or operate the truck if you are in doubt about the effectiveness of the parking brake system. Contact your Landoll service representative for assistance.

Replacing the Parking Brake Cable

1. First, review "General Maintenance Instruction," on page 1-2.
2. Set the Keyswitch to OFF and remove the key from the Keyswitch.
3. Perform a Lock Out/Tag Out procedure.
4. Disconnect the battery.
5. Make sure all the other wheels are securely blocked so that the truck cannot move.
6. Remove the hydraulic valve cover to expose the parking brake mechanism.
7. Remove the cable from the truck noting how the cable is positioned.
8. At the park lever, pull the pin that connects the cable to the park brake linkage.
9. At the caliper, remove the bolt that holds the yoke to the caliper. Remove yoke, tension spring and the two flat washers, noting placement on the old cable. Replace parts on the new cable positioning yoke in the same location.
10. Feed the new cable from the parking brake lever to the wheel motor in the same manner as the one removed, then connect both ends.
11. Adjust the parking brake cable - see "Adjusting Parking Brake Caliper," page 3-15.
12. Reassemble in reverse order.

Parking Brake Caliper Assembly

The parking brake caliper assembly is used for holding the forklift in place while unattended, it is activated by pulling the park brake lever.

Adjusting Parking Brake Caliper

1. First, review "Before You Begin," page 1-1.
2. Set the Keyswitch to OFF, then remove the key from the Keyswitch and disconnect the battery.
3. Make sure all the other wheels are securely blocked so that the truck cannot move.
4. Loosen adjustment bolt jam nut.
5. Adjust the actuator adjustment bolt to desired position.

IMPORTANT

The parking brake caliper adjustment should be set so when the park brake lever is screwed all the way out (completely counterclockwise) and the lever is pulled to its full vertical position, so the caliper holds the wheel. Refer to "Bendi 55 AC Parts Manual", F-596.

6. Tighten adjustment bolt jam nut.
7. Reassemble in reverse order.

Changing Parking Brake Pads or Caliper

1. First, review "Before You Begin," page 1-1.
2. Set the Keyswitch to OFF, then remove the key from the Keyswitch, perform a Lock Out Tag Out procedure and disconnect the battery.
3. Make sure all the other wheels are securely blocked so that the truck cannot move.
4. Remove 3/8"-16 x 1-1/4" round head square neck screws and nuts from park brake bracket. See Figure 3-3.

IMPORTANT

The parking brake caliper and bracket will be loose when hardware is removed. Remove the parking brake caliper carefully so that the caliper pads, backing plate, and actuator pin do not fall.

5. Either remove caliper for replacement or replace brake pads with new ones.
6. Reassemble in reverse order.
7. If needed, adjust caliper. See "Adjusting Parking Brake Caliper," on page 3-15.

Hydraulic

Changing Hydraulic Oil

1. Review "Before You Begin" on page 1-1.
2. Park the truck on a level, designated service area.
3. Set the parking brake and block the rear wheels.
4. Perform Lock Out/Tag Out procedure.
5. Set the key to OFF and remove the key from the Keyswitch.
6. Disconnect the battery.
7. Remove the left floor plate cover. Reference "Floor Plate Removal" on page 3-33.
8. Open the fill/dipstick cap mounted under floor plate.
9. The hydraulic reservoir drain plug is located in the bottom of the truck, underneath the reservoir. See Figure 3-7.
10. Slide a flat collection pan, (minimum 10 gallons (40 liters)) under the drain plug, then remove the plug.
11. Change the hydraulic filter. See "Change the Hydraulic Oil Filter" on page 3-16.
12. Clean the magnetic trap on the drain plug of any contaminants. When the tank is empty, clean and reinstall the drain plug.
13. Add hydraulic oil. See page 1-8 for recommended lubricants. DO NOT overfill.
14. Replace the fill/dipstick cap, turn clockwise, and make sure it is tightened securely.
15. Make sure the drain plug is tight enough to prevent oil leaks, but do not over tighten. Refer to Torque Specifications on page 1-8.
16. Remove Lock Out/Tag Out notices and locks.
17. Run lift to check for leaks.
18. With the lift OFF and the forks down, check the oil level on the dipstick and add oil accordingly.



Figure 3-7: Hydraulic Oil Drain Plug

Change the Hydraulic Oil Filter



CAUTION

After prolonged truck use, hydraulic oil will become hot and can burn skin. Allow hydraulic oil to cool to a tolerable temperature before performing this procedure.

1. Park the truck on a level, designated service area, set the parking brake and block the wheels.
2. Set the key to OFF and remove the key from the Keyswitch.
3. Perform Lock Out/Tag Out procedure.
4. Disconnect the battery.
5. Remove the operators compartment floor plate, left side.
6. Using a clean, lint-free cloth, clean the area around the filter element housing and remove the filter housing cover.
7. Unscrew the hydraulic oil filter cap and remove the old filter, clean and replace See Figures 3-8 and 3-9.



Figure 3-8: Hydraulic Oil Filter Cap

8. Operate the hydraulic system by running the mast functions and observe the filter for oil leaks.
9. Check the hydraulic fluid level and reinstall the driver's floor plate.

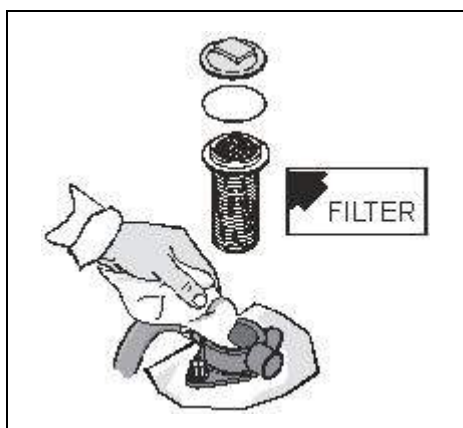

Figure 3-9: Hydraulic Oil Filter

Hydraulic Motor(s) Reassembly

1. All parts should be clean and have a light coating of hydraulic oil.
2. Pay close attention when assembling o-rings, as they can be pinched.
3. Insert the hold-down bolts into the pump body and hand tighten into the tapped holes in the truck frame.
4. Torque down the mounting bolts. Refer to torque specification tables on page 1-8.

Hydraulic Pump Service

NOTE

The hydraulic lift pump used on the Bendi B55 AC has no serviceable parts and is repaired by replacement only.

Hydraulic Components

NOTE

This section explains the following:

- Hydraulic Pump
- Hydraulic Return Filter
- Hydraulic Control Valve
- Servicing the Lift Motor and Pump



Figure 3-10: Hydraulic Pump Removal

Before Servicing Hydraulic Components:

1. First, review “Before You Begin,” page 1-1.
2. Set the Keyswitch to OFF and remove the key from the Keyswitch.
3. Apply the parking brake, perform a Lock Out/Tag Out procedure and disconnect the battery.
4. Make sure all the other wheels are securely blocked so that the truck cannot move.

Replacing the Hydraulic Pump and Motor

1. For locations reference, See Figure 3-10.
2. Remove the key and place in a secure area.
3. Perform the Lock Out Tag/Out procedure.
4. Remove the battery.
5. Remove the battery tray.
6. Move the hydraulic levers back and forth to relieve pressure from the lines.
7. Disconnect the suction and pressure hoses from the hydraulic pump, item #1. Place shop rags underneath the connections to catch hydraulic oil.
8. Mark and disconnect the 2 snap electrical connectors, item #2.
9. Mark and disconnect the 3 heavy gauge electrical cables, item #3.
10. Insert wooden blocks underneath the counter weight closest to the hydraulic motor - right side.
11. Hold and steady the counter weight with a floor jack.
12. Remove the 1-8 x 4 upper counter weight bolt, item #4. Note: The removal of the bolt is for motor removal clearance.
13. Remove three 3/8” fasteners, items #5, to allow the pump and motor assembly to be elevated out of the frame.
14. Using an overhead hoist, remove the pump and motor assembly from the truck and place it in the repair area.

NOTE

Assembly is very heavy.

15. Re-assemble in reverse procedure.

Hydraulic Control Valve Assembly

The following procedure explains how to replace a valve should a sluggish or sticking valve spool be suspect.



Figure 3-11: Operator Controls

IMPORTANT

If you remove the valve from the truck for servicing (hex head screws and hardware), when reinstalling the valve be certain to tighten the mounting screws in a staggered fashion while applying equal pressure to all screws. If the screws are not tightened and torqued evenly, you could create a stress crack, thus internal oil leaks, rendering the valve defective.

NOTE

- The main hydraulic pump for lift, tilt, pivot, and shift (mast functions) is a fixed displacement gear pump (2.008 cu. inch/rev). System pressure must not exceed 3,000 psi, ± 65 psi (205 bar, ± 4 bar) maximum. Actual pressure is determined by mast size, load requirements and lift speed.
- The main pump pressure relief valve is part of the hydraulic control valve.
- A pressure gauge port is provided, with a "quick-coupler," (pressure service kit, Landoll p.n. 0018152) for reading the pump pressure on the hydraulic control valve. The pressure check port on the forklift is attached to the inlet port on the hydraulic control valve. See Figure 2-5.

IMPORTANT

- Before you service this valve for possible pressure problems, make sure there are no leaks in the hydraulic system and that there is sufficient oil in the tank. Both conditions can contribute to low pressure problems.
- Also see "Mast Systems," in the Bendi B55 AC Series Operator's Manual F-595 for additional circuit information.

Hydraulic Control Valve and Switches Removal

1. First, review Before You Begin on page 1-1.
2. Set the Keyswitch to OFF, remove the key from the Keyswitch, perform a Lock Out/Tag Out procedure and disconnect the battery.
3. Apply the hand brake and block the wheels.
4. Relieve pressure in the system by moving the hydraulic levers back and forth a few times.
5. Remove the floor plate.
6. Remove valve cover.
7. Inspect the spool actuator end (upper) and the switch actuator end (lower) for leakage. Also inspect valve for leakage between valve sections.
8. If leakage is found, the spool seals can be replaced. If there is leakage within the spools, as determined by drift in the hydraulic actuator, the valve may need to be replaced. If leakage is found between sections, replace o-ring between the section.
9. Remove the valve from the truck by first identifying and marking all hoses, disconnecting and plugging all hydraulic tubes. Be prepared to manage spills.
10. Disconnect the lift pot from the truck wiring harness and switches from the truck wiring harness at the Deutsch connector.
11. Remove the push/pull linkage from the spools by removing the cotter pins and pulling the pins from the spools.
12. Remove the bolts holding the valve to the valve mounting bracket.
13. Place the valve on a bench or in a vice.
14. Seals can only be removed by removing the spools.
15. Remove the lift pot/switch mounts by removing the mounting screws.
16. Remove the fasteners on the spool actuation end and remove the cover plate(s).

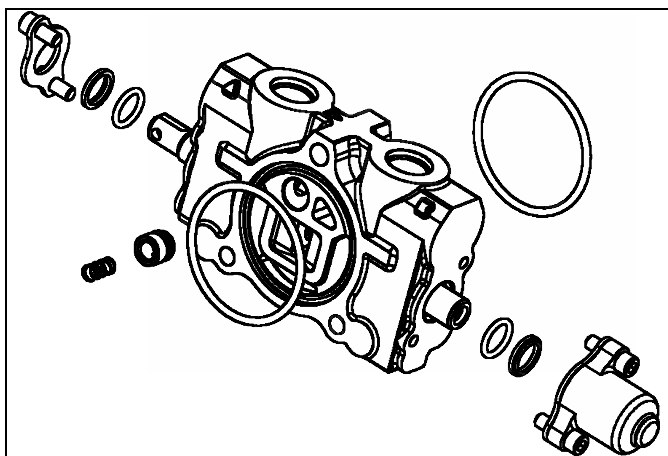

Figure 3-12: Hydraulic Control Spool

NOTE

During this time close inspection should be given looking for leaks between the sections. If there have been sectional leaks, simply unbolt the three bolts that hold the sections together, replace the leaking o-ring and tighten up the bolts holding the sections together. See "Hydraulic Control Valve" in F-596 Bendi B55 AC parts book.

17. Remove the spool and end mechanism from the bore.
18. Remove the seal, wiper and seal plate from the tang/clevis end of the spool. A dental pick can be used to remove the wiper and o-ring. Use caution to avoid nicking the bore.
19. Remove the end mechanism from the cap end of the spool.
20. Remove all foreign material from the spool and seal counter bores.
21. Lubricate the seal groove bores on the cap and tang/clevis ends of the housing.
22. Re-assemble the cap end of the spool with the new seals per the applicable end mechanism repair instruction and carefully reinsert the spool.
23. Install the new seal and wiper on the tang/clevis end of the spool using the seal plate to push them in prior to completing the seal plate cap screw installation and torque.
24. Assemble the switch pot brackets to the other end of the valve.
25. Apply grease (NLSI #2 Texaco #880) to the actuator end prior to assembly of the spool actuator.
26. Reassemble the valve into the truck.
27. Attach and tighten all hoses.
28. Operate the valve functions and check for leaks.

Spool Section Rebuild

NOTE

The inlet assembly will include an o-ring, and the spool sections will include an o-ring, load check poppet and load check spring.

1. For proper reassembly alignment, lay the valve components on a clean, hard, flat surface.
2. Thread the tie rod nuts onto the short threaded end of each of the individual tie rods with the nuts threaded up the entire length of the threads.
3. Insert the tie rods through tie rod holes of the inlet housing, lay the inlet on the end with tie rods pointing up and install the o-ring into the groove. Special care must be taken to ensure the o-ring has been completely installed in the groove.
4. Place the first spool section over the inlet section with the o-ring groove facing upward and install the o-ring into the groove.
5. Install the load check poppet into the load check cavity, nose first.
6. Once the load check poppet has been properly installed, place the load check spring in the hollow cavity, inside the check poppet.

Lift Spool Sensor

Replacing the Lift Spool Sensor

1. First, review Before You Begin on page 1-1.
2. Set the Keyswitch to OFF and remove the key from the Keyswitch.
3. Apply the parking brake, perform a Lock Out/Tag Out procedure, disconnect the battery and block the wheels.
4. Relieve pressure in the system by turning the steering wheel two times to the left, then two times to the right and move the controls in both directions.
5. Remove the side cover and floor plates to access the valves.
6. Disconnect the valve wiring harness.
7. Remove the wires from pin locations 1-3.
8. Remove the two screws holding the sensor to the valve section.
9. Crimp new pins onto the wires of the new lift spool sensor.
10. Insert the red wire into pin position 1, the black wire into position 2 and the green wire into position 3.
11. Re-install the lift spool sensor onto the lift valve section.
12. Tighten all hydraulic hoses.

13. Start the truck, operate the hydraulic system, and check for leaks.
14. Re-install the side cover and floor plates.
15. Calibrate the lift sensor to the controller. Refer to page 4-1 for calibration instructions. This adjustment is actually completed through the controller electronically.
16. Reinstall the brake assembly.
17. Install the floor plates and valve cover.

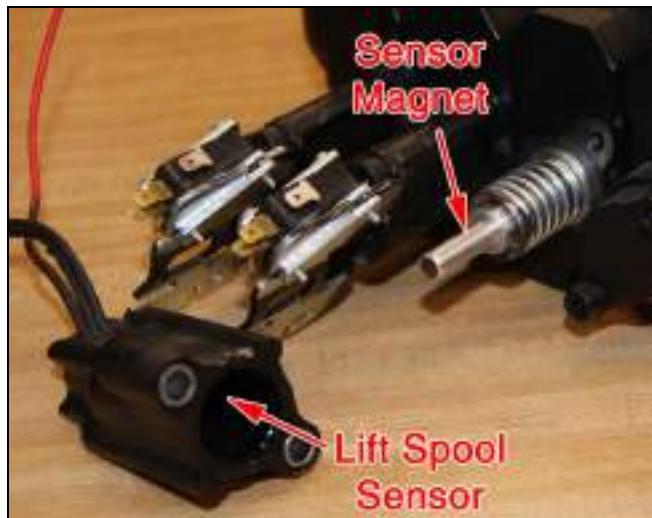

Figure 3-13: Lift Spool Sensor

Hydraulic Fittings and Hoses

1. First, review “Before You Begin,” on page 1-1.
2. Set the Keyswitch to OFF and remove the key from the Keyswitch.
3. Perform a Lock Out/Tag Out procedure, disconnect the battery and block the wheels.
4. Before disconnecting any hydraulic fittings or hose assemblies, relieve the system pressure. This is accomplished by turning the steering wheel a few times in both directions, and moving the control levers in both directions after the Keyswitch is turned OFF.



WARNING

- High pressure hydraulic oil leaks can pierce the body and cause **SEVERE** injury to personnel. Always reduce pressure before opening any hydraulic pressure line.
- Oil spills can cause falls. To avoid injury, make sure all spills are cleaned well with oil dry/wipes.

5. Remove the hose coupling from the defective fitting. Use two wrenches; one wrench to loosen the hose coupling, and one to prevent the fitting from turning. Be prepared to clean up any oil spillage. See Figure 3-14.
6. Always tag the hoses and fittings for identification. If necessary, keep notes and put markings on the parts using a non-destructive marker.
7. Remove the defective fitting and replace with a new fitting. Use two wrenches; one wrench to tighten the hose coupling, and one to prevent the fitting from turning.

NOTE

SAE fittings do not need a thread sealant. They are straight thread and include an O-ring seal.

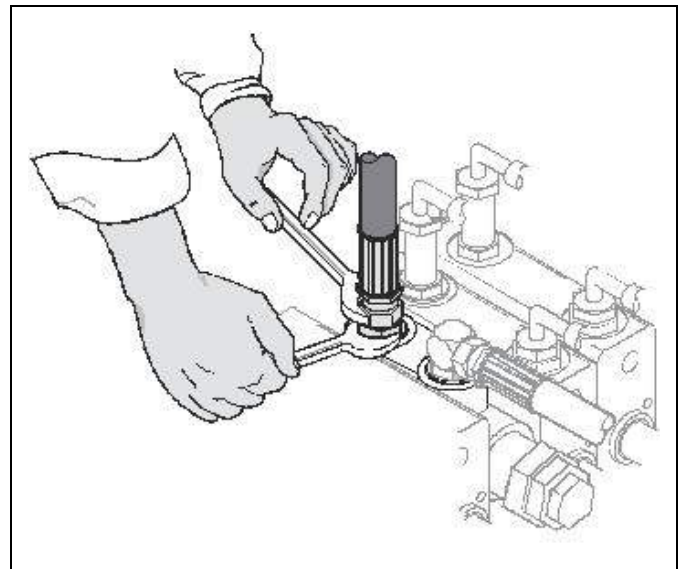

Figure 3-14: Hydraulic Connections

Drive System

Replacing the Drive Tires



WARNING

Make sure that replacement drive tires are of the same size and composition as originally supplied by the Landoll Corporation. Tire composition can effect braking, capacity, turning and operator safety. These tires are in interference type, meaning the tires are pressed on and pressed off. Both drive tires must be replaced at the same time to maintain uniform size, performance and stability.



CAUTION

Replacing pressed-on tires should be done only by technicians who have been specifically trained for this procedure and have the specific tools to perform this job.

1. Park the truck at a level, designated work area. Lower the forks and chock the wheels.
2. Perform a Lock Out/Tag Out procedure as explained on page 1-3.
3. Lift the truck so that the tires are just off the floor.
4. Remove the lug nuts and the drive tire assembly from the drive train.
5. Press the existing tire off the hub.
6. Verify that the replacement tire has the same specs as what Landoll specifies.
7. Press the replacement tire onto the hub. Make sure the outside of the tire is flush with the hub.
8. Install the tire/hub assembly onto the truck and finger tighten the lug nuts.
9. Torque the lug nuts to 225 ft. lbs. (300 Nm.)

Disassembling and Inspecting Wheel Bearings

1. First, review "Before You Begin," on page 1-1.
2. Throughout these instructions, See Figure 3-15.
3. Lift the axle and support it so that the wheels are free to rotate.
4. Measure the tire diameter. If the diameter of the tire is less than 13", Landoll recommends that the tire be replaced.

5. Remove the hub cap, 5/32" x 1-1/2" cotter pin, 1-14" hex slot nut, spindle washer, and the outer bearing cone.
6. Slide the hub/wheel assembly from spindle. Remove the inner bearing cone and seal from hub.
7. Clean the bearing cones and seal. Clean the bearing cups inside the hub.
8. Examine for wear or damage. Replace the bearing if rollers are pitted, rusted, or cracked.
9. Replace the bearing cups if the cups are cracked or pitted.
10. Replace the seal if worn or damaged.

NOTE

Pre-pack the bearings with grease before replacing. Bearing cups and cones must be replaced as a set.

Assembling Wheel Bearings

1. If the bearing cups are replaced, clean the hub and press the new bearing cups into the hub. See Figure 3-15.
2. Pack the wheel bearings with grease.
3. Place the outside face of wheel down on the bench. Insert the inner bearing and carefully drive the seal in until flush with the hub.
4. Carefully slide the hub, bearing, and the seal assembly onto the spindle.

IMPORTANT

Be careful! Avoid damaging grease seal. A damaged seal must be replaced.

5. Insert the outer bearing cone and washer. Tighten the hex slot nut against the spindle washer.
6. Adjust the bearing preload by slowly rotating the hub while tightening the hex slot nut until resistance is felt. (Approximately 75 ft./lbs) Back the nut off 1/16 of a turn or until a notch aligns with the spindle cross-hole.
7. Readjust if the wheel does not rotate smoothly.
8. Secure the nut in place with a new cotter pin.
9. Ensure that the cavity between the two wheel bearings is filled with grease by injecting grease into the grease fitting at the top of the steering yoke, until the grease flows through the outer bearing.
10. Apply a thin layer of grease onto the hub cap o-ring and press the hub cap into the hub.
11. Reinstall the wheel and tire assembly.

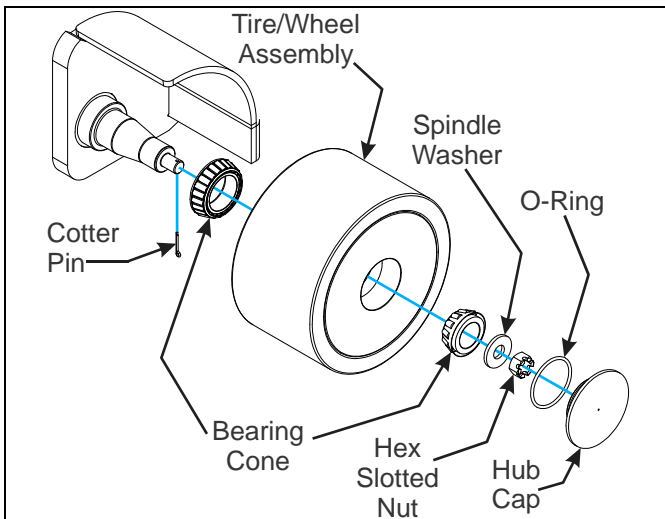

Figure 3-15: Wheel Bearing Inspection

Drive Wheel Assembly

Check Planetary Gear Box

NOTE

The planetary drive gear box (right and left side) assemblies (2) are filled with oil at the factory. An oil change is necessary after the first 50 hours maximum of operation in order to remove particles worn down during the breaking-in phase. Thereafter, an oil change is only required once every 2000 hours or yearly, whichever comes first. Also, if the truck has been in storage for one year or more, the oil should be changed before placing the truck into operation.



DANGER

- Perform service only in a well-ventilated area.
- Do not breathe vapors.
- Wear protective goggles, aprons and gloves.
- Avoid contact with skin, eyes and clothes.
- If you become dizzy, get fresh air and medical help immediately.
- If a solvent contacts your eyes, immediately treat in accordance with the manufacturer's recommendations on the container.
- Do not mix different types of lubricants.
- Always read the label affixed to the fluid container for all safety information before use.
- Failure to observe these precautions may result in death or injury.

1. Position the truck on a flat surface, set the parking brake and block the wheels to prevent movement.

2. Set the Keyswitch to OFF and remove the key from the Keyswitch.
3. Perform Lock Out/Tag Out & disconnect the battery.
4. Raise the vehicle. Use jack stands, or other suitable supporting device, to support the vehicle.
5. Raise the drive wheel(s) to allow the tire to rotate.
6. Remove the wheel from the unit being serviced.
7. Thoroughly clean the area around the fill and drain/level plugs.

IMPORTANT

Always place an appropriate support stand under the truck if it is being lifted. Lower the truck to the stand, having both the lifting device and stand supporting the weight of the truck.



DANGER

Getting under a truck when it is lifted or jacked is dangerous and could cause serious injury or death. NEVER go under a truck that is supported only by a jack.

8. To drain, turn the gear box so that one of the drain plugs is at the lowest point. If rotating the gear box proves difficult, brace a 2" x 4" (5cm x 10cm) block between the wheel studs and rotate. See Figure 3-16.
9. Place a drain pan capable of storing up to 32 ounces (1.0 liter) of fluid under the drain plug.
10. Using a 4 mm Allen key, unscrew the drain/level (position A) and fill (position B) plugs.
11. Drain the fluid completely into the drain pan.



CAUTION

If the truck has just been in operation for a period of time the oil could be very hot. Use special gloves and/or allow the truck to cool before changing the oil. It is best to drain fluid while the unit is warm, but not HOT! Never drain oil into sewer lines.

12. Once the fluid has been drained, replace the drain/level plug in position A.
13. Wash the interior of the gear box with cleaning liquid as recommended by the lubricant manufacturer.
 - Put liquid into the gear box through the fill plug and replace the fill plug.
 - Run the gear box for a few minutes at a high speed.
 - Drain the cleaning liquid from the gear box in the same way as described for draining the oil.

- Clean any contaminants from the magnetic trap and O-ring seal on the plugs.
14. To fill the gear box, turn until the drain/level hole in position A is about 15° below the horizontal center line of the gear box.
 15. Fill the gear box with synthetic gear lube through position B until fluid flows out from position A. Fluid capacity is approximately 1 pint(16 oz.).

NOTE

DO NOT OVERFILL.

16. Install both plugs. Tighten to 25 ft. lbs. (34 Nm).
17. Wipe off any oil spillage on the outside of the gear box.
18. Turn the gear box a few times to eliminate any air pockets and recheck fluid level. The oil level should be checked again after a short driving period. If necessary, re-fill the oil.

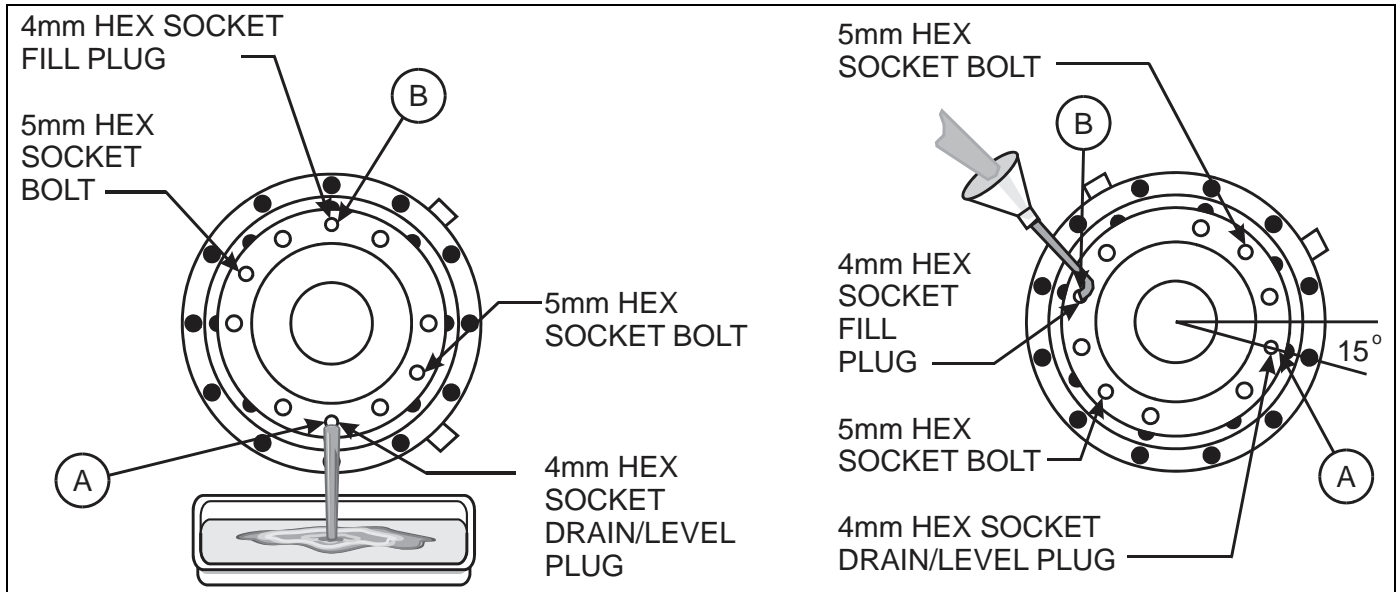

Figure 3-16: Drain/Fill Gearbox

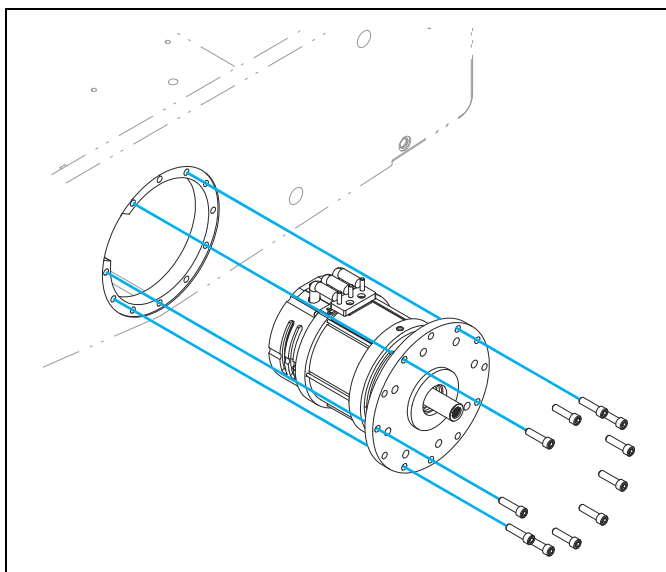

Figure 3-17: Drive Motor Assembly

Exposing and Maintaining the Traction Motors

The Bendi 55 AC truck is equipped with a left and a right traction motor and also a motor that powers the hydraulic pump. The traction motors have sensors to monitor speed and position. The motors used on the Bendi 55 AC lifts are AC motors and have no brushes. Motor maintenance consists of keeping the motors clean with the use of compressed air.

To repair and/or replace the traction motors:

1. Set the parking brake and block all the wheels not being serviced.
2. Set the Keyswitch to OFF and remove the key from the Keyswitch.
3. Disconnect the battery.
4. Perform the Lock Out/Tag Out procedure.
5. Remove the battery.
6. Remove the battery floor plate to expose the motor cover.
7. Remove the Brake Caliper and Rotor referencing "Disc Brake Rotors" on page 3-12.

8. Remove the twelve 1/2-20 X 2 hex socket screws (Item #1) and hardware holding the motor to the motor mount weldment. See Figure 3-17.
9. Support the unit as the mounting bolts are removed.
10. With the motor supported, rotate the motor to align the electrical connecting terminals to the slots machined in the motor mount weldment.
11. Slide the motor out far enough to install a second strap around the motor. This strap is to support the motor from outside the truck frame.
12. Place the assembly on a sturdy work bench. Use wood planks to balance and support the assembly while on the workbench.
13. Assemble the new motor by following the preceding steps in reverse.
14. Tighten and torque the screws. See torque specifications on page 1-8.

Electrical

Battery - Safety, Care & Replacement

Battery Safety - Duplicate of Safety Notices Shown in Chapter 1.

Battery Safety Rules:



CAUTION

- **Wear protective clothing, rubber apron, boots gloves and full-face shield when performing any maintenance on batteries.**
- **DO NOT allow electrolyte to come in contact with eyes, skin, clothing or floor. If electrolyte contacts eyes, flush immediately with clean water. OBTAIN MEDICAL ATTENTION IMMEDIATELY!**
- **Should electrolyte be spilled on skin, rinse promptly with clean water and soap. A baking soda solution (one pound to one gallon of water) will neutralize acid spilled on clothing, floor or other surfaces. Apply solution until bubbling stops and rinse with clean water.**
- **Keep battery vent plugs firmly in place at all times, except when adding water or taking hydrometer readings.**
- **DO NOT bring any type of flame or spark near the battery.**
- **DO NOT place any electrically conductive tool on the battery that could cause a spark. Gas formed while the battery is charging is highly explosive. This gas remains in the cells long after charging is complete.**
- **Keep the battery clean. Foreign matter in the electrolyte will result in poor battery performance.**
- **Follow the battery manufacturer's instructions concerning maintenance and repair.**

Battery Care and Charging

CAUTION

- Only qualified and experienced personnel should perform maintenance and repair on batteries.
- Make certain the charger being used matches the voltage and amperage of the truck battery. This voltage is listed on the truck serial plate. See Figure 1-1.
- Before connecting or disconnecting batteries to the charger, make sure the charger is OFF. Attempts made to do this while the charger is ON could result in serious injury to the operator and damage could occur to the charger with sparks or electrical spikes.
- Keep sparks or open flame away from the battery or the charging area. **BATTERY FUMES ARE EXPLOSIVE!**
- NEVER have an open flame or embers near the battery. Gas formed during charging is explosive and can cause injury. Consult the charger manufacturer's manual covering your charger for operation and maintenance.
- The battery must meet size, weight and voltage requirements of the truck.

To use a hydrometer:

- Remove a cap from one or two of the cells. Gently squeeze (compress) the bulb of the hydrometer.
- Insert the tube of the hydrometer into the cell electrolyte. Slowly release the bulb to allow fluid to draw into the hydrometer. Enough fluid must enter the hydrometer to allow the float to move freely.
- The specific gravity of the electrolyte is read off the scale of the float where it emerges from the fluid.
- It is good practice to select many different and multiple cells.

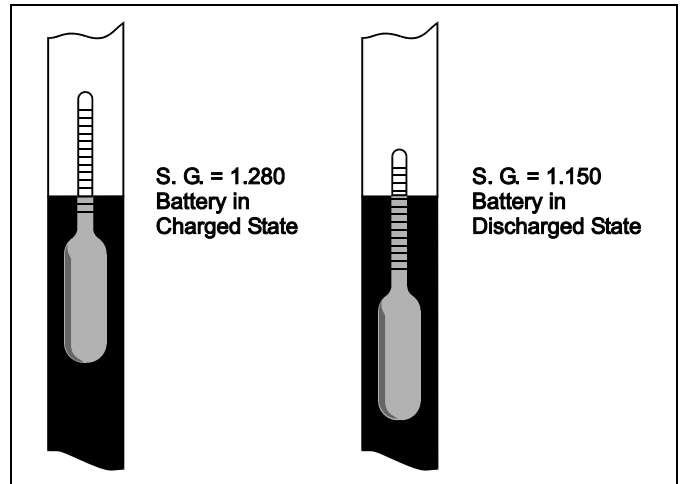

Figure 3-18: Hydrometer

1. Park the truck at the designated charge area with forks down and key OFF.
2. Make sure charger is in the OFF position. Connect the battery to the charger and make certain cables are firmly connected.
3. Turn the charger on and set the timer, if equipped. For an overnight fill, set charger to NORMAL.
4. View the charger gauge to be positive of charge.
5. Check and fill the batteries after charging.

Removing the Battery From the Charger

1. Make sure the charger is off and disconnect the charger cables from the battery with a straight pulling motion. Store the charging cables appropriately.
2. Check the battery for the appropriate electrolyte level and measure the specific gravity.

Using a Hydrometer

As the battery discharges the specific gravity of the electrolyte lowers. A hydrometer allows you to check the specific gravity of the cells, thus the charge state of the battery.

Temp °F	Correction	Temp °F	Correction
39-41	-0.012	101-103	+0.008
42-44	-0.011	104-106	+0.009
45-47	-0.010	107-109	+0.010
48-50	-0.009	110-112	+0.011
51-53	-0.008	113-115	+0.012
54-56	-0.007	116-118	+0.013
57-60	-0.006	119-121	+0.014
61-63	-0.005	122-124	+0.015
64-66	-0.004	125-127	+0.016
67-69	-0.003	128-130	+0.017
70-72	-0.002	131-133	+0.018
73-75	-0.001	134-136	+0.019
76-78	0	137-139	+0.020
79-81	+0.001	140-142	+0.021
82-84	+0.002	143-145	+0.022
85-87	+0.003	146-148	+0.023
88-91	+0.004	149-151	+0.024
92-94	+0.005	152-154	+0.025
95-97	+0.006	155-157	+0.026
98-100	+0.007	158-160	+0.027

Table 3-1: Specific Gravity Electrolyte Corrections

Battery Removal and Installation



CAUTION

Battery Removal:

- When removing the battery move the truck to an area intended for battery care, on a level floor.
- Turn the Keyswitch to the OFF position and remove the key.
- Disconnect battery and lock out the truck as described in the Lock Out/Tag Out section described on page 1-3.
- Never remove the battery partially from the truck without a roller stand in place.
- Lower load completely. If battery is removed with load raised, use hoist attached to mast to protect against tip over.
- DO NOT allow any metallic object to come in contact with the top of the battery. This may cause a short circuit when removing or transporting the battery. Use an insulator (such as plywood) to cover the top of the battery during removal.



CAUTION

Battery Installation:

- When installing the battery move truck to an area intended for battery care.
- The load forks must be all the way down to the floor.
- Turn key or toggle switch to OFF position and put the key in a secure place.

Good Battery Care Recommendations:

- Add approved water only - never add acid.
- Keep electrolyte levels proper.
- Keep battery top clean and dry.
- Keep flame and metal away from battery top.
- Keep vent caps tightened.
- Cool before charging/operating battery above 115°F.
- Use only an approved, correct volt/current, charger.
- Keep battery cover open while charging.

If in doubt, call your local Landoll service technician.

Cleaning the Battery

When properly maintained, the battery will remain relatively clean and dry. It may be necessary to clean the top of the battery. Occasionally it may be necessary to remove excessive electrolyte. If this happens, remove the battery from the truck and clean with a solution of baking soda and water. (one pound baking soda to 1 gallon of water) Rinse the battery off with water and allow to air dry.

Battery Removal



CAUTION

Don't allow metallic objects to be on top or near the battery. A short could cause an electrical arc and personal injury may result. When moving the battery, keep the top of the battery covered with an insulator, such as a piece of plywood or tarp.

Rollout Battery Removal - optional

1. Remove the safety retainer bar, deactivating the safety switch.
2. Position the battery roll out stand next to the truck and align the stand with the path of the battery.
3. Roll the battery onto the stand.

Battery Installation

1. Change and charge batteries in accordance with ANSI/NFPA 505.
2. Check to be sure the key is off.
3. Open the right hand door.
4. If using a rollout stand, position the battery stand next to the truck. Align stand with battery compartment. Battery roller stand should be at the same height as the truck.
5. Push battery into the truck's battery compartment or lower if using a hoist.
6. Install the rollout battery arm bar, or the truck will not operate. See Figure 3-19.
7. Connect the battery.

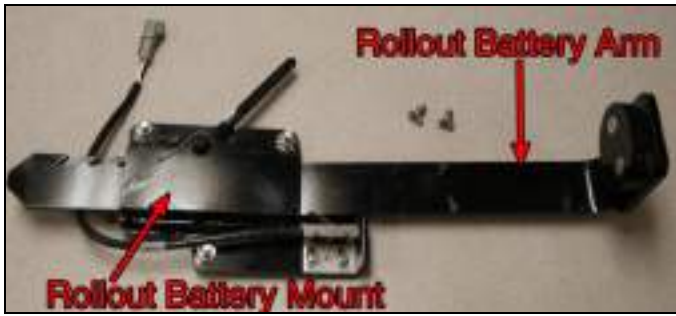

Figure 3-19: Rollout Battery Arm Bar

Electrical Controls and Levers

Direction Control Lever

NOTE

The directional control lever (forward-neutral-reverse) is located on the lift lever. Each assembly is available as a complete unit.

Replacing Direction Control Switch

1. First, review “Before You Begin,” page 1-1.
2. Set the Keyswitch to OFF and remove the key from the Keyswitch.
3. Apply the parking brake, perform a Lock Out/Tag Out procedure and disconnect the battery.
4. Make sure all the other wheels are securely blocked so that the truck cannot move.
5. Remove the control lever cover.
6. Remove the lift lever wires from the contact blocks on the main harness.
7. Replace in reverse order.
8. Test for proper operation.



Figure 3-20: Control Panel Wiring

Replacing a Complete Control Panel

1. First, review “Before You Begin,” page 1-1.
2. Set the Keyswitch to OFF and remove the key from the Keyswitch.
3. Apply the parking brake, perform a Lock Out/Tag Out procedure and disconnect the battery.
4. Make sure all the other wheels are securely blocked so that the truck cannot move.
5. Remove the control compartment cover on the rear of the truck.

6. Mark and remove all cables connected to high current terminals of the panel and disconnect the main harness. See Figure 3-20.
7. Remove mounting hardware that secures the assembly to the truck and remove the panel from the truck.
8. Reassemble in reverse order. All cables installed on the motor controllers must use Landoll approved fasteners. Refer to the Bendi B55 AC Parts Manual for replacement parts, F-596.
9. Tighten cables connected to the high current terminals, identified on the controller housing as B+, B-, U, V and W to 90 +/- 1- in-lbs (10.2 +/- 1.1 Nm). See Figure 3-21. - for high current cables.

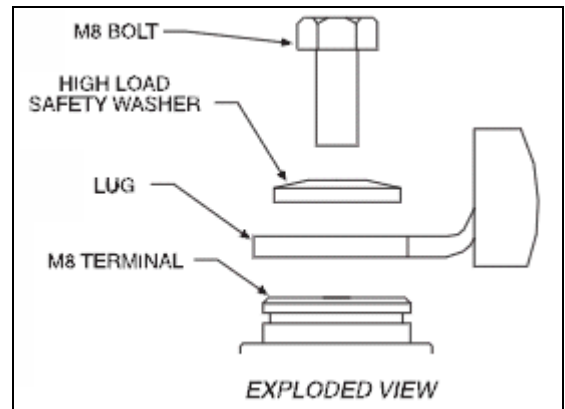

Figure 3-21: Cable Installation

NOTE

After replacing the controller it must be reprogrammed. See Chapter 4 "Calibration and Programming".

High Current Connections Definition:

B+ = Positive Battery to Controller.

B- = Negative Battery to Controller.

U = Motor phase U.

V = Motor phase V.

W = Motor phase W.

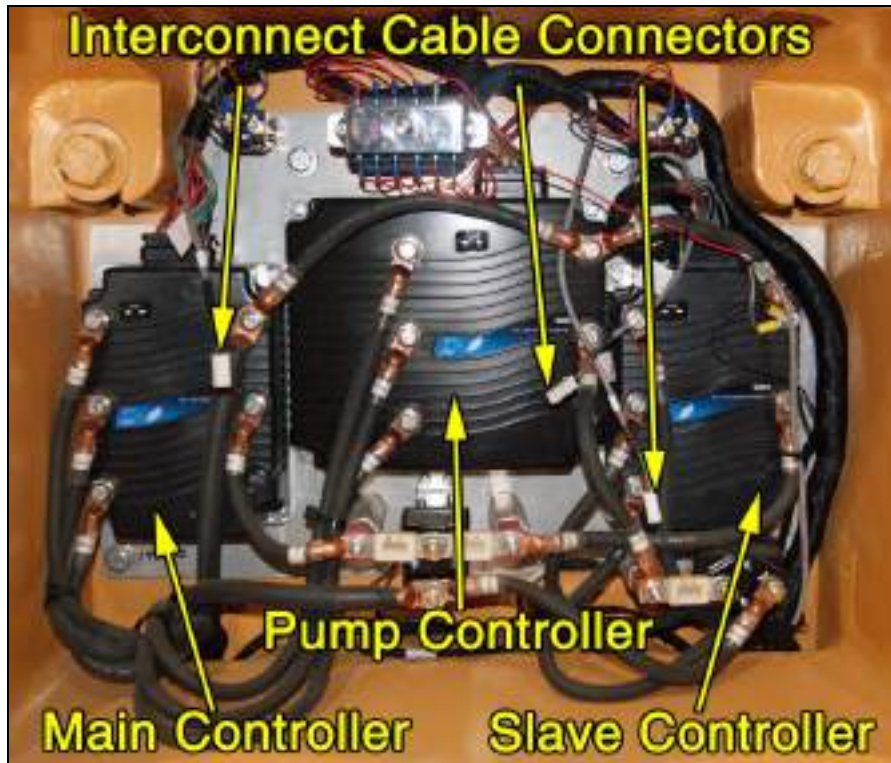

Figure 3-22: Controller Panel



Figure 3-23: Controller Fuses

Fuses

Shown above are the location of the Bendi B55 AC System and Controller fuses. See Figure 3-23. Exact size and amperage rating must but be retained when replacing.

Steering & Pedals

Brake Pedal

The service brake pedal has about 1" maximum free-play before any pressure is applied to the brakes, (or before the pedal moves the master cylinder plunger).

The pedal also has a maximum range of travel of up to only 0.500" (12.7 mm) before it contacts the positive stop hex screw, and includes a brake light switch that energizes the brake STOP lights, where applicable, and has a switch for disengaging traction drive. The brake light/accelerator switch is factory set to trip just as the brake pedal begins its downward stroke.

Service Brake Linkage

1. First, review "General Maintenance Instructions," on page 1-2.
2. Set the Keyswitch to OFF, remove the key from the Keyswitch, perform a Lock Out Tag Out procedure and disconnect the battery.
3. Before doing any adjustment, proceed to the appropriate heading for:
 - Low fluid level in the master cylinder reservoir.
 - Air or leaks in the system
 - Worn brake pads. See "Changing Brake Pads," page 3-10.
 - Any of these conditions can affect pedal free-play.
 - Proceed to the appropriate heading for repairs.
4. Remove the left floor plate to expose the brake pedal linkage and master cylinder, See "Floor Plate Removal," page 3-33.
5. Loosen the 5/16" free play adjustment nut on the master cylinder push rod. See Figure 3-24.
6. Turn the rod clockwise to increase dimension on the pedal; turn counterclockwise to decrease dimension. See Figure 3-24. For free play adjustment dimension.
7. Tighten the adjustment lock nut against the brake pedal yoke.
8. Install the left floor plate.
9. Connect the battery and check for proper brake operation as follows:
 - Raise and block the truck off the ground.
 - Accelerate the forklift to full speed.
 - Apply the brakes to quickly STOP the wheels.

TROUBLESHOOTING & CORRECTIVE MAINTENANCE

- Release the brake pedal after the wheels stop, then accelerate again to full speed.
 - Release the accelerator pedal to allow the wheels to coast to a stop.
 - Both wheels should stop at the same time.
 - Repeat this procedure two times in forward and in reverse directions.
10. If the forklift does not perform as stated above, reinspect the brake calipers for wear.

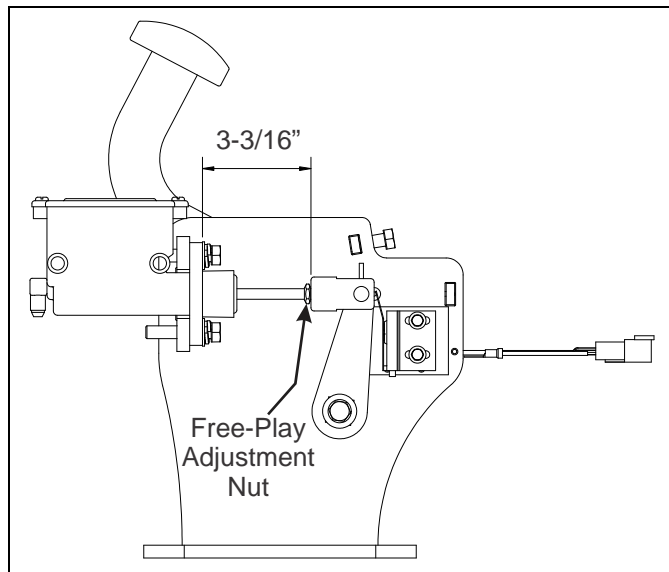

Figure 3-24: Brake Linkage

Pedal Adjustments

Brake Switch Adjustment

1. First, review "Before You Begin," page 1-1.
2. Set the Keyswitch to OFF, remove the key from the Keyswitch, perform the Lock Out/Tag Out procedure and disconnect the battery.
3. Slightly loosen both brake switch hex head screws. See Figure 3-25.
4. Connect the ohm meter leads to the brake switch leads.
5. Slowly push down on the brake pedal. Before you feel pedal resistance, the meter must read one of the following:
 - The meter must show a reading of open at the full upright pedal position for brake lights (2 black wires).
 - The meter must show a reading of closed (or less than 1 ohm) at the full upright pedal position for accelerator switch (2 green wires).
6. Slide the brake switch forward or backward to locate the switch at this position - to engage immediately as the pedal begins its downward stroke. See Figure 3-24.

7. Carefully tighten and torque the screws (8 to 10 ft. lbs.; 11-14 Nm) to secure the switch without moving the setting, then release the brake pedal to verify the setting.
8. Disconnect the ohm meter.
9. Start the truck.
10. Apply the brakes while checking that the lights turn ON before pressure is applied to the master cylinder.

NOTE

To avoid "flat-spotting the tires, do not lock the brakes when stopping.

Replacing the Brake Pot

To replace the linear pot, disconnect the connector to the assembly and remove the 2 bolts holding the assembly into position and replace the assembly. Install so that potentiometer rod has a minimum of 1/16" pre-load. All other calibration is required through the dashboard calibration procedure. See page 4-1.

Brake Switch Replacement

1. First, review "Before You Begin," page 1-1.
2. Set the Keyswitch to OFF and remove the key from the Keyswitch.
3. Perform Lock Out/Tag Out procedure.
4. Disconnect the battery, block the wheels and release the parking brake.
5. Remove floor plates. See "Floor Plate Removal," page 3-33.
6. Unscrew and remove the switch assembly from the brake pedal frame and install the new switch. See Figure 3-25.
7. To set the switch see "Brake Switch Adjustment" on page 3-30.

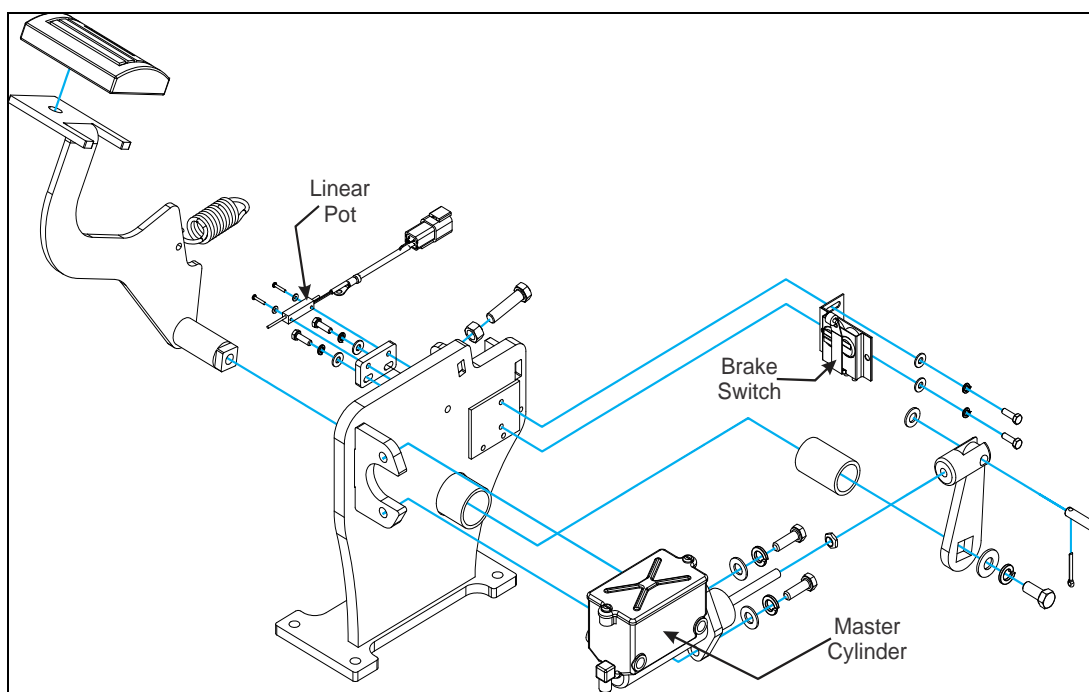

Figure 3-25: Brake Switch Assembly

Checking Accelerator Switch/Pot

1. First, review “Before You Begin,” page 1-1.
2. Set the Keyswitch to OFF, remove the key from the Keyswitch, perform the Lock Out/Tag Out procedure and disconnect the battery.
3. Remove accelerator assembly. (See “Floor Plate Removal” on page 3-33.)
4. Connect the ohm meter leads to pins 4 and 5 (blue and green wires).
5. Without pushing on the pedal the meter must read open (or greater than 10k ohm).
6. Press on the accelerator approximately 1’2”. The meter should now read as closed (or less than 1 ohm).
7. Connect the ohm meter leads to pins 1 and 2 (black and white wires).
8. Without pushing on the pedal the meter must read closed (or less than 1 ohm).
9. As you press on the accelerator, starting at approximately 1/2” the meter should proportionally show an increase in resistance up to 5k ohm at full 30° deflection.

IMPORTANT

If any of the above steps don’t yield the correct results, the accelerator must be replaced. The accelerator is modular and can not be repaired.

Master Cylinder

Replacing Master Cylinder

1. First, review “Before You Begin,” page 1-1.
2. Set the Keyswitch to OFF and remove the key from the Keyswitch.
3. Perform the Lock Out/Tag Out procedure.
4. Apply the parking brake, disconnect the battery and block the wheels.
5. Remove floor plates. See “Floor Plate Removal,” page 3-33.
6. Remove the master cylinder fill cap and rubber diaphragm (two round head screws). See Figure 3-25.

NOTE

Note: Siphon out as much fluid as possible. Install and tighten the fill cap and diaphragm before removing the cylinder.

7. Place rags under the brake line connections. Have a plastic cap or bag handy to cover the end of the line to limit fluid spillage.

IMPORTANT

Brake fluid will damage paint. Cover truck body parts and be careful not to spill fluid during this procedure. Wipe up any spilled fluid immediately, then flush the area with clean water.

- Using a flare-nut wrench, disconnect the brake fluid line at the rear of the cylinder.

NOTE

Flare-nut wrenches should be used to prevent rounding off the flats.

- Carefully pull the brake line away from the cylinder. Seal or plug the brake line and master cylinder port to prevent fluid loss and/or contamination.
- Disassemble the yoke from the master cylinder crank plate (one 5/16-18 screw and hardware).
- Remove the two master cylinder mounting bolts and remove the cylinder from the truck.
- Remove the reservoir cap and discard any fluid remaining in the reservoir.
- Mark the push rod lock nut setting, then remove the yoke and lock nut from the old cylinder and install it to the new cylinder, maintaining the same lock nut setting.

NOTE

- The push rod lock nut should be installed so that when the pedal is completely assembled and retracted, the yoke to the master cylinder crank plate hardware is loose.
 - Whenever the master cylinder is removed or replaced, the hydraulic brake system must be bled. The time required to bleed the system can be reduced if the master cylinder is filled with brake fluid and bench-bled before installing the cylinder into the truck. See "Bench Bleed the Master Cylinder," below.
- Replace the new master cylinder in reverse order.

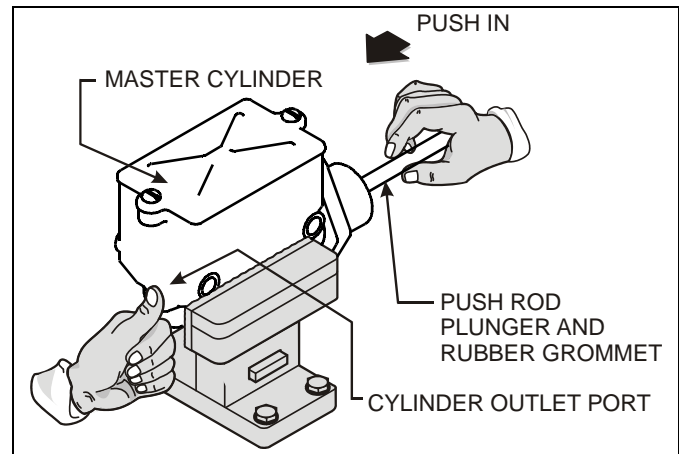

Figure 3-26: Bench Bleeding

Bench Bleed the Master Cylinder

- Support the cylinder in a vise to prevent fluid spillage, while allowing you to push the internal piston with the push rod. See Figure 3-26.
- Remove the filler cap and fill the cylinder with DOT 3 brake fluid.
- Slowly push in on the rubber boot and cylinder plunger (push rod) assembly to force air from the cylinder, then hold the push rod in. See Figure 3-26.
- Press your finger tightly over the master cylinder outlet port to prevent air from being drawn back into the cylinder when you release the push rod, or feed a separate line (flexible tubing) from the cylinder port(s) and immerse the other end in the container of new brake fluid. Wait several seconds to allow fluid to be drawn from the reservoir to the cylinder bore, then repeat this step. When you push the push rod in again it will force your finger from the master cylinder outlet port to expel any trapped air. Place rags under the brake line fitting to manage any fluid loss.
- When only brake fluid is expelled from the master cylinder outlet port, hold the push rod in and seal the master cylinder outlet port with an appropriate threaded plug or plastic cap, then release pressure on the push rod.
- Fill the master cylinder reservoir and install the filler cap and gasket.

Service Brake Pedal Assembly

NOTE

The service brake assembly (brake pedal) includes the mechanical brake pedal assembly, containing a pivot bushing. The only normal repair items are the switch, the pivot bushing, or the brake return spring.

Replacing Any Other Hydraulic Brake Component

1. First, review “Before You Begin,” on page 1-1.
2. Set the Keyswitch to OFF and remove the key from the Keyswitch.
3. Perform Lock Out/Tag Out procedure and disconnect the battery.
4. Apply the parking brake.
5. Make sure all the other wheels are securely blocked so that the truck cannot move.
6. Remove covers as needed.
7. Replace the damaged component and reassemble.
8. Make all adjustments needed to insure brakes are operating correctly.
9. Test the operation of the forklift truck brakes.

Floor Plate Removal

NOTE

This panel provides access to the accelerator assembly which is mounted to the underside of the right side floor plate. The master cylinder and service brake pedal and linkage are mounted under the left side floor plate.

1. Thoroughly clean the floor area using a vacuum.
2. Without tearing, pull up the rubber floor mat.
3. Remove the left floor plate from the truck frame. See Figure 3-27.
4. Carefully lift the right floor plate. The accelerator pedal assembly will still be attached to the right floor plate.

NOTE

The accelerator module electrical harness will restrict how far the plate can be lifted. To fully remove the plate you must disconnect the electrical harness.

5. Reassemble in reverse order.

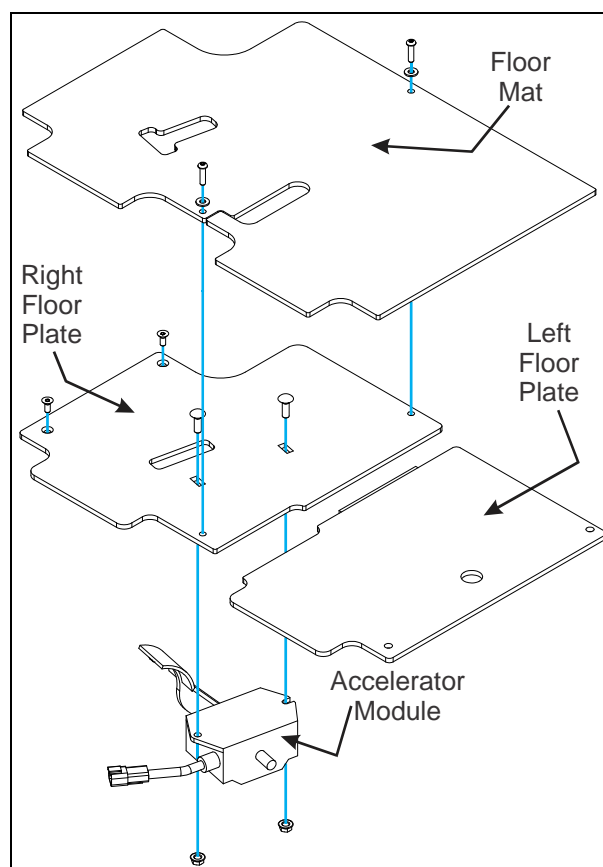

Figure 3-27: Floor Plate

Accelerator Pedal Assembly

NOTE

The accelerator assembly consists of the linear potentiometer, harness, and accelerator pedal.

Adjusting Accelerator Pedal

1. First, review “Before You Begin,” page 1-1.
2. Set the Keyswitch to OFF and remove the key from the Keyswitch.
3. Block wheels and perform the Lock Out/Tag Out procedure.
4. Remove the right floor plate.
5. Note: It is recommended to hold the right hand floor plate in a vice while doing this procedure.
6. Loosen the allen head fastener on the pedal arm so that it can rotate freely. Rotate the pedal until the pedal touches the rear of the slot. Tighten the fastener.
7. Install floor plate assembly back on the forklift.
8. Install right hand floor plate.

9. Refer to Landoll Setup Procedure, located in "Calibration of Steering and Throttle Pot" starting on page 4-1 to re-calibrate the throttle pot module.

Replacing Accelerator Module

1. First, review "Before You Begin," page 1-1.
2. Set the Keyswitch to OFF and remove the key from the Keyswitch.
3. Apply the parking brake, perform a Lock Out/Tag Out procedure, disconnect the battery and block all wheels.
4. Remove the right side floor plate. See "Floor Plate Removal", on page 3-33.
5. Remove the two round head screws (5/16-18 x 1) and hardware securing the accelerator to the floor panel. See Figure 3-27.
6. Disassemble the accelerator from the floor plate and install the replacement accelerator in its place. See Figure 3-27.
7. Loosen the allen headed fastener on the pedal arm and orient the pedal 90 degrees up. Insert the flat part of the arm through the slot, rotate and mate the accelerator mounting surface to the underside of the floor plate. Align with the 5/16" bolts and tighten to secure the accelerator.
8. Adjust the pedal, See Adjusting Accelerator Pedal, above.
9. Re-calibrate the software beginning on page 4-1.

Power Steering System Maintenance

Guidelines to perform maintenance on the power steering system is provided in the following paragraphs:

- Fluid for the hydraulic power steering system comes from the central hydraulic reservoir.
- Always use a puller to remove the steering wheel. Do not use a hammer or crow bar.
- Investigate and immediately correct any play, rattle, shimmy, misalignment, or other unusual occurrence in the steering system.
- Report any malfunction or accident that may have damaged a steering system part.
- Investigate and correct any external leak in the steering system, no matter how minor the leak.
- Do not attempt to weld or straighten any broken steering component. Replace the component with original equipment only.



CAUTION

Prevent dirt or other foreign matter from entering the hydraulic system; clean filler caps before checking oil level.

Filling and Air Bleeding the Power Steering System

Fill and air bleed the power steering system per the schedules shown starting on page 2-1.

1. Fill the reservoir until it is between the F and E marks on the dipstick.
2. Run the steering through three complete cycles by turning the steering wheel all the way in one direction, then all the way the other direction.
3. Check and refill the reservoir after each cycle.
4. Add fluid until it is between the F and E marks on the dipstick. DO NOT OVERFILL.

Steering Wheel Removal

1. Pry the plastic cover from the steering wheel using your finger tips. If you cannot grab the cover, you can start it by carefully using a small pry bar and gently prying upwards. **DO NOT** force it or the cover may crack. See Figure 3-28.
2. Loosen the steering wheel nut.
3. Pry the steering wheel upwards by wiggling and pulling straight up. It is important to pull up evenly on both sides of the wheel.

NOTE

If the wheel is difficult to remove, use an automotive-type steering wheel puller. Avoid using hammers or pry bars.

4. Install the steering wheel by placing it over the shaft, aligning the wheel and shaft splines and pushing downward evenly until the nut can be installed.
5. Tighten the nut.

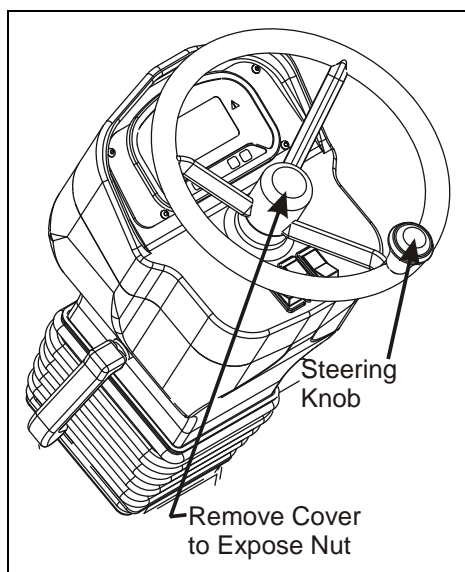

Figure 3-28: Steering Wheel Assembly

Steering Column (Console) Removal

NOTE

This is a two man operation, due to weight of steering column (approximately 30 pounds/14 kgs.). If an overhead crane is available, the crane could be strapped to the steering wheel for support.

1. Remove floor plates. See "Floor Plate Removal," page 3-33.
2. Remove the lower dash cover weldment. See Figure 3-29.
3. Disconnect the plugs that connect the dash harness to the main harness and any optional lighting harnesses.
4. Relieve hydraulic pressure in the system by turning the steering wheel a few times to the left and right.
5. Pry (up) the bellows (rubber boot) free of the bellows retainer plate. This exposes the mounting plate for the steering column and the orbital control unit.

IMPORTANT

Four screws secure the assembly to the orbital steering mount bracket for stability. Once removed the unit is supported by the hydraulic hoses only.

6. Remove the four bolts and hardware securing the orbital control unit to the steering column.
7. Remove the four bolts and hardware securing the steering column console to the bellows retainer plate. See Figure 3-29.
8. With help, lift the steering column upwards to disengage the shaft from the orbital unit, then remove the steer column from the truck.

9. When installing the new steer column, you must turn the steering shaft until it aligns with the orbital unit and drops into place.
10. Continue by reversing the preceding steps. Make sure to tighten and torque all mounting screws. See General Torque, Hydraulic Fitting Torque, and Bendi 55 AC Special Torque Tables in on page 1-8.

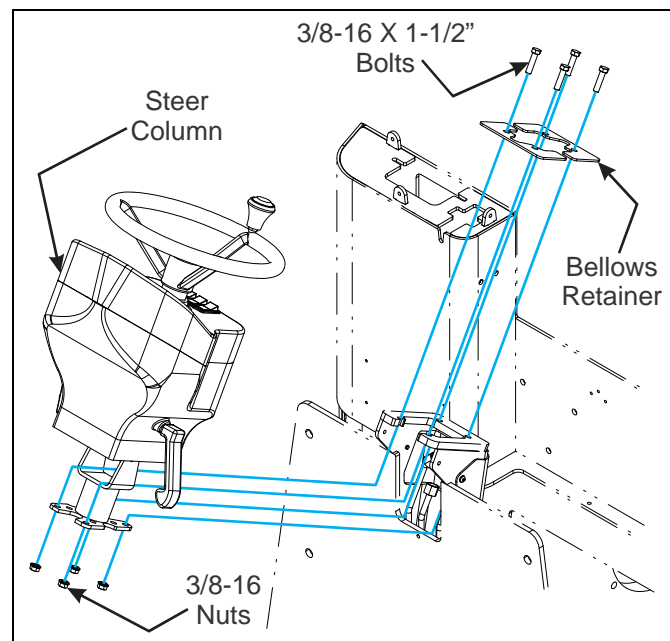

Figure 3-29: Steer Column Assembly

Steering Orbital Control Unit

1. Remove floor plates. See "Floor Plate Removal," page 3-33.
2. Remove the column piping cover - the panel right below the steering bellows.
3. Relieve hydraulic pressure in the system by turning the steering wheel a few times to the left and right.
4. Tag the port locations of each hydraulic line and fitting, then disconnect the four lines from the unit.
5. Review section "Hydraulic Fittings and Hoses," on page 3-20.

NOTE

Immediately plug and cap all hose ends and tag each for identification. Be prepared to clean up any oil spills.

6. If the unit is being replaced, or the fittings are defective, notice the placement angle of the hose fittings then remove them. See Figure 3-30.
7. Install the new steering orbital control unit to the steering column by following the preceding steps in reverse order.
8. Check oil level in the hydraulic tank and fill as needed.

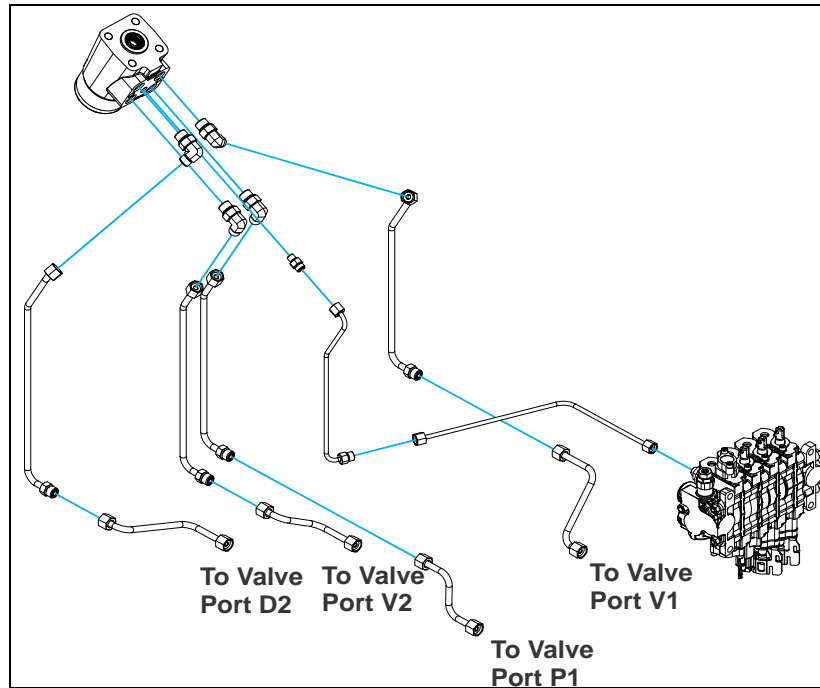



Figure 3-30: Orbital Steering Control Unit Assembly

9. If the unit is being replaced, or the fittings are defective, notice the placement angle of the hose fittings then remove them.
10. Install the new steering orbital control unit to the steering column by following the preceding steps in reverse order.
11. Check oil level in the hydraulic tank and fill as needed.

 CAUTION
<p>Before any maintenance or work is performed on the electrical system of the truck, perform a Lock Out/Tag Out procedure, disconnect the battery, raise the truck and put blocks on the underside of the truck</p>

Steering Column/Dash Assembly

The following procedures describe access to and replacement of the steering console electrical components, as well as all other electrical components on the Bendi 55 AC forklift.

The console assembly includes the following and are accessible by removing the right side steering assembly cover (black) - screws and hardware:

- *Auxiliary power rocker switch (fan, scanner, etc.)*
- *Headlights (rocker switch, where fitted)*
- *Standard/Ramp mode (Allows current to increase in the ramp mode)*
- *Tilt steering lever*
- *Keyswitch*

Replacing the Display Panel

1. First, review “Before You Begin” beginning on page 1-1.
2. Set the Keyswitch to OFF and remove the key from the Keyswitch.
3. Apply the parking brake, perform a Lock Out/Tag Out procedure and disconnect the battery. Make sure all the wheels are securely blocked so that the truck cannot move.
4. Remove the steering wheel by first removing the center boot covering the steering wheel locking nut and then loosen and remove the steering wheel.
5. Remove the four 10-32 X 1/2 socket cap screws and hardware marked (A), See Figure 3-31.
6. Remove the screws and hardware marked (B).
7. Reach inside the steering column and disconnect the appropriate display wire connectors from the main wire harness.
8. Install the new display by reversing the above steps.

9. Connect the wire connector to the display and close the steering column by reversing the steps outlined in 4 through 8.

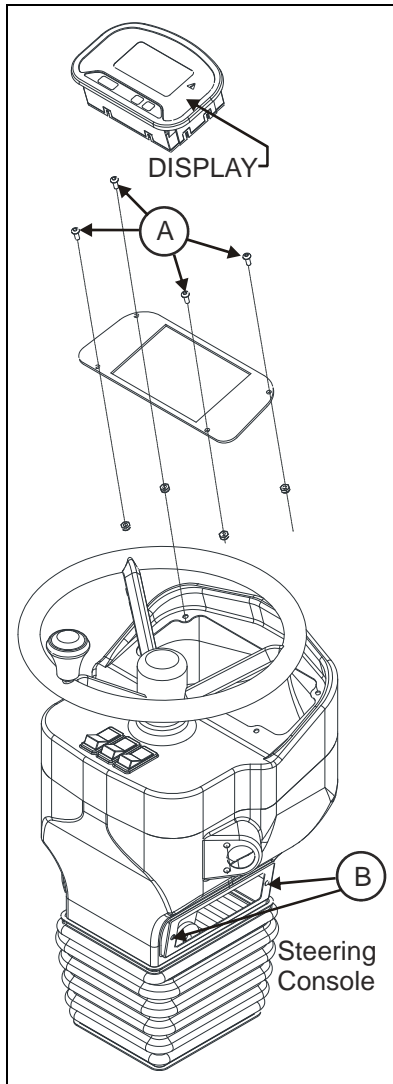

Figure 3-31: Steering Console and Display

Replacing the Keyswitch

1. Remove the right side cover to expose the internal components of the steering column as described on page 3-36.
2. Unscrew the knurled switch collar ring to separate the switch from the base plate. See Figure 3-32.
3. Disconnect the wires from the switch terminals noting how they are connected to ensure proper orientation when connecting the new switch.
4. Install the Keyswitch by reversing the preceding steps.

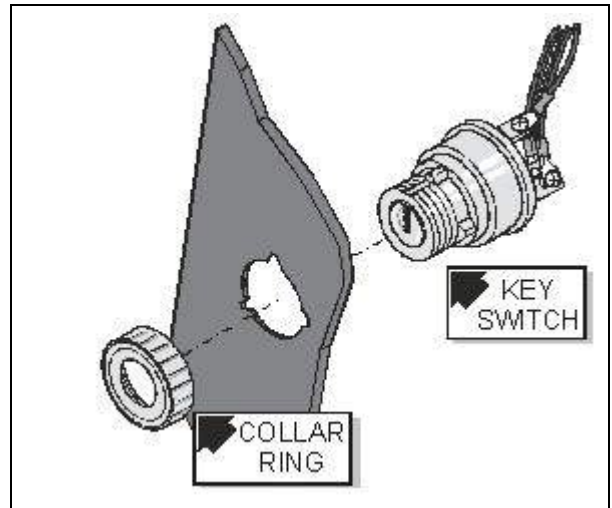

Figure 3-32: Keyswitch Installation

Rocker (On/Off) Switches

NOTE

Rocker switches are also used to control various light packages and accessories.

1. Remove the right side cover to expose the internal components of the steering column as described on page 3-36
2. Reach inside the steering column and disconnect the appropriate accessory switch connector from the main wire harness.
3. The accessory on/off rocker switches are held by plastic tabs. Compress the tabs on one side at a time to release the switch body, then push up and lift out of the slot. See Figure 3-33.

NOTE

Be careful when compressing and pushing the switch in or out. The tabs could break off if the procedure is not done carefully and evenly on all sides.

4. Detach the wires from the defective switch, noting the connection arrangement for when installing the new rocker switch.
5. Insert the replacement switch in the slot and compress the tabs as needed to allow it to insert.
6. Connect the cable connector to the wire harness and close the steering column by reversing the steps as outlined above.



Figure 3-33: Rocker Switch Removal

Safety Features

Horn Control Service

NOTE

The horn button is located on the back side of the lift lever.

Removing the Horn Control

1. Turn the Keyswitch OFF, remove the key, perform Lock Out/Tag Out procedure and disconnect battery.
2. Remove the control lever cover.
3. Disconnect the wiring connector for the lift control.
4. To remove the knob from the lever, loosen the M3 set screw. The set screw is at the base of the molded black plastic on the same side as the horn button.
5. By removing the two M1.5 screws at the top of the knob you can access the internal parts, including the horn control.
6. Using an M16 open ended wrench, unscrew the protective top and remove.
7. To replace, unsolder the wires leading to the horn control and resolder the same colored wires to the same locations on the new part. See Figure 3-34.
8. Replace in reverse order.
9. Test for proper operation.



Figure 3-34: Lift Knob Wiring

Seat Assembly

Seat Switch

The driver's seat micro switch and cable assembly are mounted to the bottom of the seat cushion. See Figure 2-7.

Replacing the Switch and Cable

1. First, review "Before You Begin" beginning on page 1-1.
2. Set the Keyswitch to OFF and remove the key from the Keyswitch.
3. Apply the parking brake, perform a Lock Out/Tag Out procedure, disconnect the battery and block all wheels.
4. Remove the hardware securing the front portion of the seat slide rails to the cover. Then loosen the back two sets of hardware.
5. Raise the front of the seat up to expose the switch and cable mounting.
6. Have a helper disconnect the switch cable from the main harness, then unscrew the switch assembly.
7. Install the new switch and cable by performing the preceding steps in reverse order.
8. Before placing the truck back into operation, test it to be sure the switch functions properly.

Truck Lighting

Trucks equipped with optional lighting, flashing or spot lights may contain replaceable bulbs or the housing may be replaced as a whole. Lighting replacement varies according to the manufacturer.

Headlights

These lights have non-replaceable elements and are replaced as an entire unit.

Brake and Tail Lights

1. First, review "Before You Begin" beginning on page 1-1.
2. Set the Keyswitch to OFF and remove the key from the Keyswitch.
3. Perform the Lock Out/Tag Out procedure.
4. Apply the parking brake and disconnect the battery.
5. The complete LED light assembly must be replaced to repair a faulty light assembly.
6. Pull off the complete LED light assembly. Exercise care to avoid breaking the LED assembly.
7. Disconnect the wire connector and remove the bracket that is attached to the overhead guard.
8. If shielding or guard covers are involved, make certain that the guard is replaced after the repair. Reassemble in reverse order.

Back Up Alarms

1. First, review Before You Begin on page 1-1.
2. Set the Keyswitch to OFF and remove the key from the Keyswitch.
3. Perform the Lock Out/Tag Out procedure.
4. Apply the parking brake and disconnect the battery.
5. To access the alarm assembly, raise the seat base as it is located under the arm rest.
6. To replace the alarm assembly, disconnect the wire connector and remove the mounting hardware holding the alarm to the mounting bracket.

Overhead Guard, Lighting and Alarms

Trucks equipped with optional LED flood / headlights, tail and stop lights, flashing or spot lights (strobe lights), etc. do not contain replaceable bulbs. Bulb replacement must be done as a complete assembly.

Calibration & Programming

Controller Theory of Operation

The Bendi 55 AC truck uses Curtis controllers that convert DC battery power to 3-phase AC power by precisely controlling the induction drive for high bandwidth, efficiency and low ripple torque generation. The Dual Drive feature of Curtis controllers allow 2 controllers to work in vehicles with dual fixed axle drive motors, a steered wheel or axle, and an analog steer-angle sensor. The 2 controllers should be the same size and model. Different models of controllers cannot be mixed. The 2 controllers control motor speed on the inner and outer wheels during turns, as well as vehicle speed and acceleration while turning. Current is automatically balanced between the 2 traction motors when driving straight, and a limited operating strategy (LOS) allows limp-home in case of a steer angle sensor, single motor or controller failure.

The Display is shown here for reference:

Button #1 “Enter Key” - Used to Enter the Calibration Mode and to make selections after they are located.

Display directions:

You must hold the enter button down until the change has been accepted.

Button #2 “Up Key” - Used to move “Up” through the selections.

Button #3 “Down Key” - Used to move “Down” through the selections.



Figure 4-1: Dash Display

Dash Display Parameters

The following parameters can be adjusted through the dash display:

- Maintenance Monitor - Used to set the hour meter value at which the operator will be alerted that service is required, NXT SVC DUE. When the truck meets or exceeds the value entered in this section, “SERVICE DUE” will be shown on the display.
- Steer Potentiometer (Steer Pot) Setup - Used to calibrate the steering position potentiometer.
- Accelerator Potentiometer (Accelerator Pot) Setup - Used to calibrate the accelerator potentiometer.
- Lift Potentiometer (Lift Pot) Setup - Used to calibrate the lift potentiometer.
- Brake Potentiometer (Brake Pot) Setup - Used to calibrate the brake potentiometer.
- Lift Lockout Setup - This parameter allows for adjustment of the battery capacity percentage where lift lockout is initiated.

IMPORTANT

When replacement of the steering, brake, acceleration or lift potentiometer has been performed, re-calibration of the Bendi 55 AC is required.

Truck Calibration

NOTE

While in the display's calibration menus, the truck will not move forward, backward, or perform any mast functions other than lowering the forks.

Truck calibration is performed by activating the Keyswitch and performing the following procedure:

Follow the flow chart in Figure 4-2 on page 4-3

1. At the Main Screen, press and hold the ENTER button for approximately 5 seconds. This will open the calibration menu. An asterisk (*) will show your selection. You can use the Up/Down arrows to toggle the selection. Hold down ENTER to select.
 2. To adjust the screen's contrast level, select **LCD CONTRAST** and hold the enter key. Press the UP and DOWN buttons to adjust the brightness to your preference.
 3. To begin the Truck Setup, go back to the main first screen shown in Figure 4-2 on page 4-3, move the asterisk to **TRUCK SETUP** and hold the ENTER button.
 4. The next screen will give you the option to enter a password or to exit. To enter the password, select **ENTER PW** and hold enter, then use the Up/Down arrows to manipulate the value to the desired digit. Pressing the ENTER button accepts that digit and moves onto the next one. Repeat this process for each digit. After entering the correct password, the truck setup menu will be displayed.
- NOTE**
- The default password is: 4 2 3 1.*
5. If you would like a reminder for maintenance, navigate to **MAINT MONITOR** selection and adjust the Service Due Hour Meter value as you require. The digits show the number of hours in 100's until the warning is shown. To disable this option, just enter 99900 hours into the field.
 6. Next to calibrate the steer potentiometer, press the DOWN arrow button until the asterisk is to the right of **STEER POT SETUP**, press ENTER.
 7. The next screen will show what operations you will need to perform to complete the calibration. Hold down ENTER to begin.
 - The asterisk moves to the right indicating the current step in the calibration you are currently in.
 - Steer truck fully left and press ENTER. Turn Steer to straight selection and hit ENTER. Steer the truck to the right position & press ENTER.
 - When the asterisk is beside the **EXIT**, the steer pot calibration is complete.
 8. **ACCELERATOR POTENTIOMETER SETUP:** Navigate to **ACCEL POT SETUP** on the main menu and press enter. Press ENTER again to begin calibration.
 - **ACCEL ZERO** calibration - Ensure the foot pedal is in the up position and press ENTER.
 - **ACCEL FULL** - Press the pedal to the floor and press ENTER. Monitor the accelerator pot voltage on the screen; ensure this value is changing with movement of the pedal between .1VDC and 5.2VDC.
 - When the asterisk is beside the **EXIT**, the accelerator pot calibration is complete.
 9. **LIFT POTENTIOMETER SETUP:** Navigate to **LIFT POT SETUP** from the truck setup menu and press ENTER. Press ENTER again to begin calibration.
 - **LIFT LEVER ZERO** - Ensure the lift lever is in the neutral position and press ENTER.
 - **LIFT LEVER FULL** - Pull the lift lever **back** completely and press ENTER. Monitor the lift pot voltage on the screen; ensure this value is changing with movement of the lever between 2.5 VDC & 3.7V.
 - When the asterisk is beside the **EXIT**, the lift lever pot calibration is complete.
 10. **BRAKE POTENTIOMETER SETUP:** Select **BRAKE POT SETUP** from the truck setup menu and press ENTER. Press ENTER again to begin calibration.
 - **BRAKE PEDAL ZERO** - Ensure the brake pedal is in the up position and press ENTER.
 - **BRAKE PEDAL FULL** - Press the brake pedal to the floor and press ENTER. Monitor the brake pot voltage on the screen; ensure this value is changing with movement of the pedal between .1VDC and 5.1VDC.
 - When the asterisk is beside the **EXIT**, the brake pot calibration is complete.
 11. **LIFT/LOCKOUT SETUP:** Select **LIFT LOCKOUT** from the truck setup menu and press enter. Press ENTER again to begin editing.
 - Use the UP/DOWN arrows to manipulate the value to the desired percentage of battery charge before the "Limp Home" mode is activated and press enter to store the new value. This completes the LIFT/LOCKOUT.

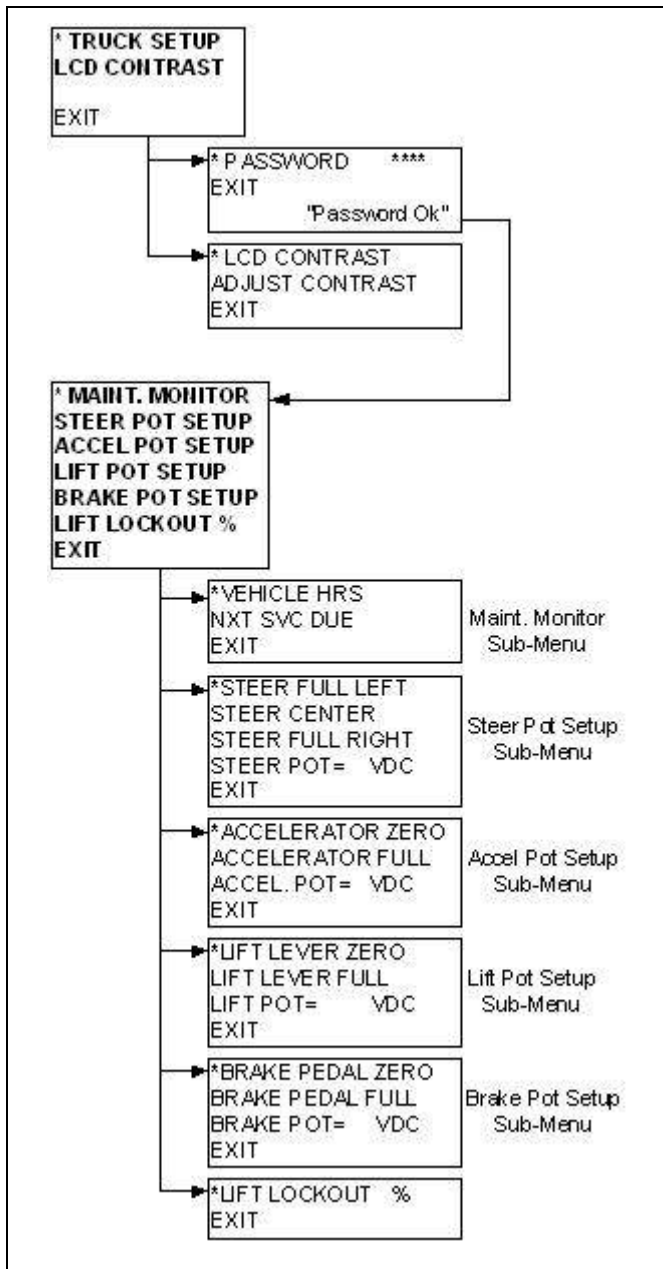

Figure 4-2: Truck Calibration Flow Chart

1314 Bendi 55 AC Controller Software Program Installation and Operation

The 1314 Controller Software is used to manipulate, monitor and diagnose the Bendi 55 AC Forklift performance and functions.

The following sections will guide you through the installation of the 1314 Controller Programming Station and explain the software program functionality.

USB to Serial Port Adaptor Cable

Depending on the configuration of your laptop, an interface cable may be needed for the software transfer between the laptop and the Bendi controllers. A 9-pin Serial to USB port adapter is needed. See Figure 4-3.



Figure 4-3: Serial to USB Adapter

NOTE

The Belkin F5U509 is a recommended model, although other suppliers of this type of adapter are available at many computer cable suppliers. Refer to See Figure 4-3..

If your laptop is equipped with a serial port you may connect the Bendi controller directly to your laptop with the supplied 1309 Curtis interface cable. See Figure 4-4.



Figure 4-4: Controller Dongle

See Figure 4-5. Shown here is the Serial to USB adaptor cable connected to the Curtis 1309 interface cable that is to be connected between the forklift controller and your laptop computer. Reference Figure 4-6 on page 4-4 for truck cable connector(s) locations.



Figure 4-5: Serial Adaptor + 1309 Interface Cable

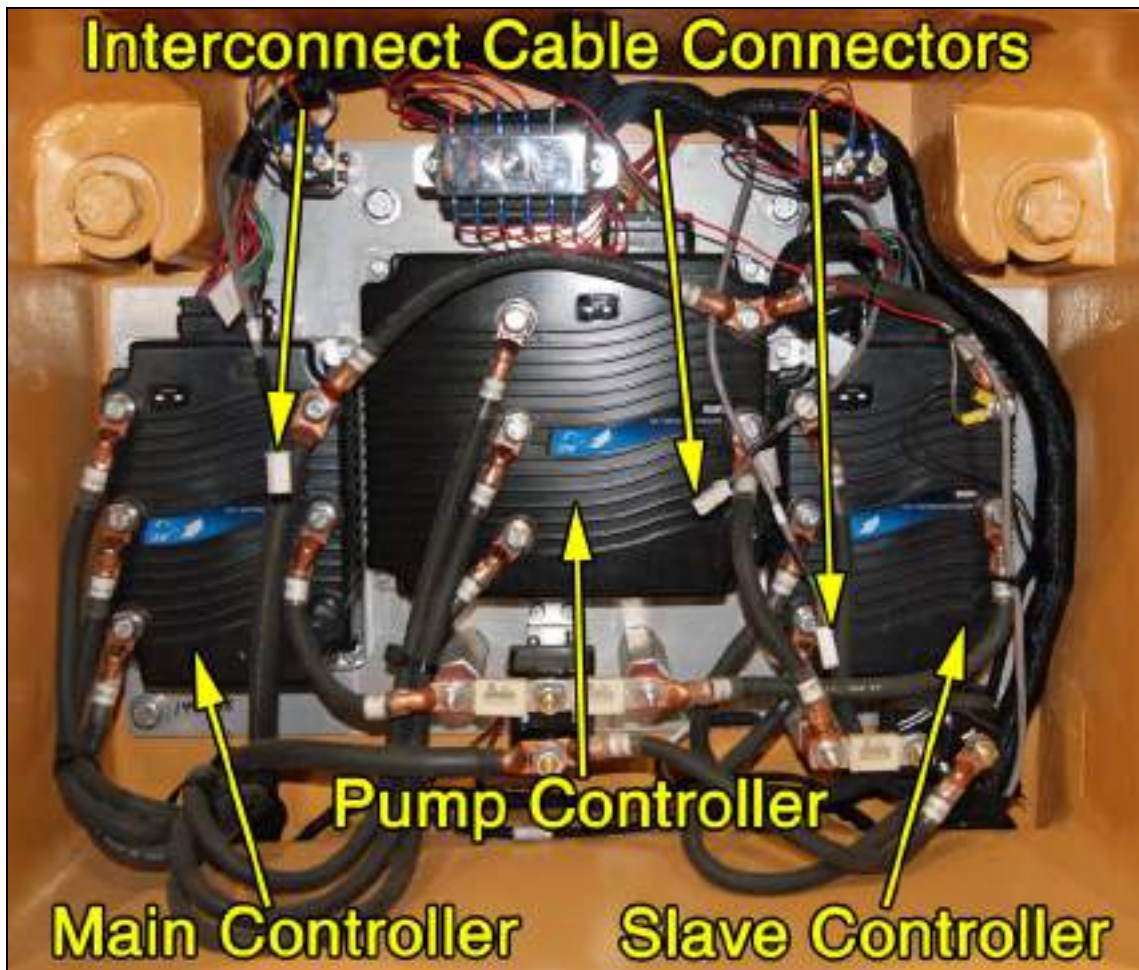

Figure 4-6: Cable Connections

1314 Installation Procedure

Follow the installation instructions below:

1. Insert Curtis 1314 PC Programming Station CD into your CD ROM drive.
2. If the screen in Figure 4-7 does not automatically appear, go to your computer directory, double click your CD ROM drive (usually D:\) and double click **setup.exe** as shown in Figure 4-8. Click **[Next]**.

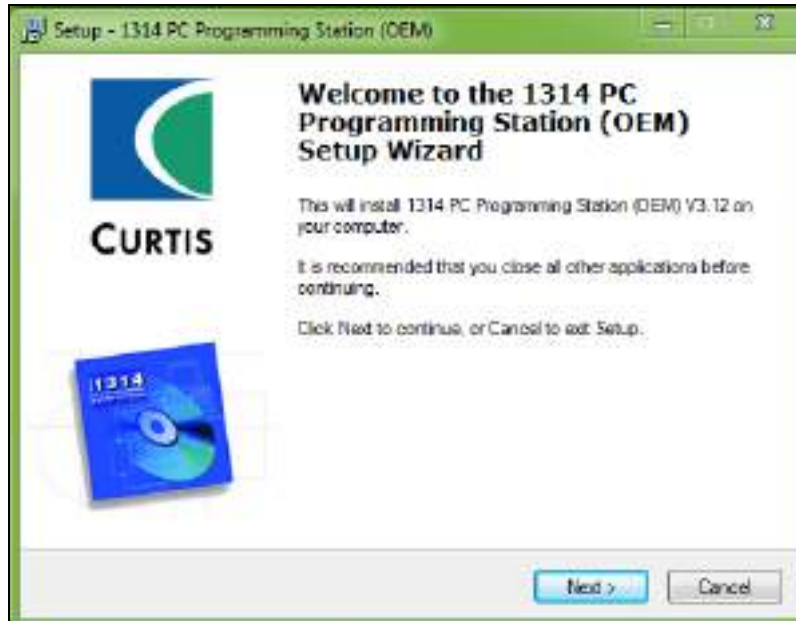

Figure 4-7: Start - Steps 1 & 2

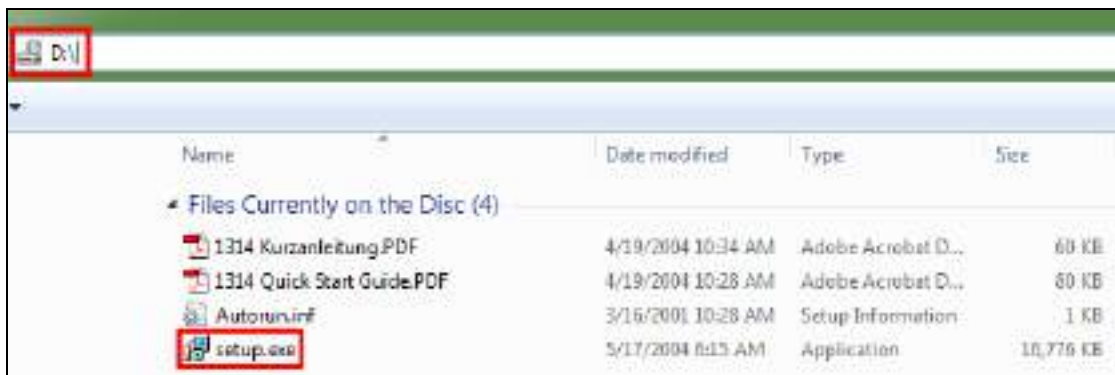

Figure 4-8: Starting Installation Program

3. Be sure to read the Software License Agreement thoroughly and understand it's contents.
4. Click the radial button beside "I accept the agreement" if you understand and agree and then click [\[Next\]](#).

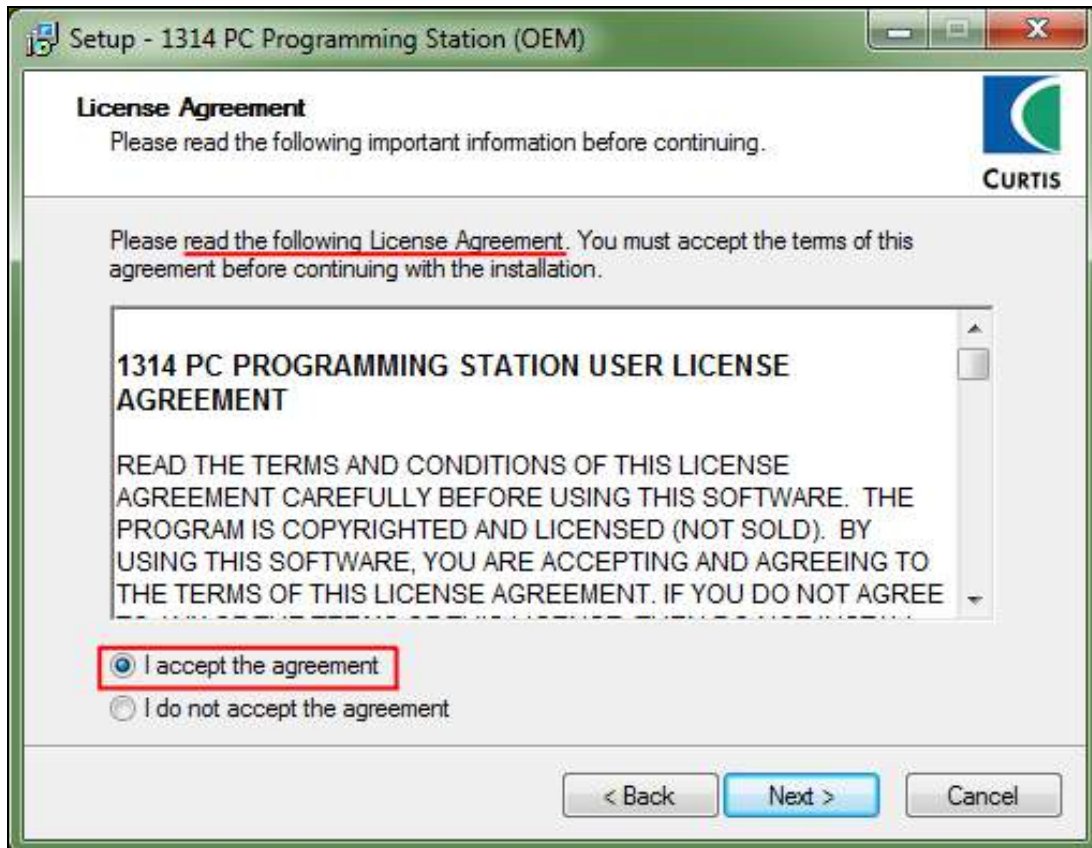

Figure 4-9: Steps 3 & 4

5. The next screen gives you the option to load the program in a specific location. In situations that multiple drives are used it may be advantageous to use this option. For most users, the location it auto-generates should be adequate. Click [\[Next\]](#).

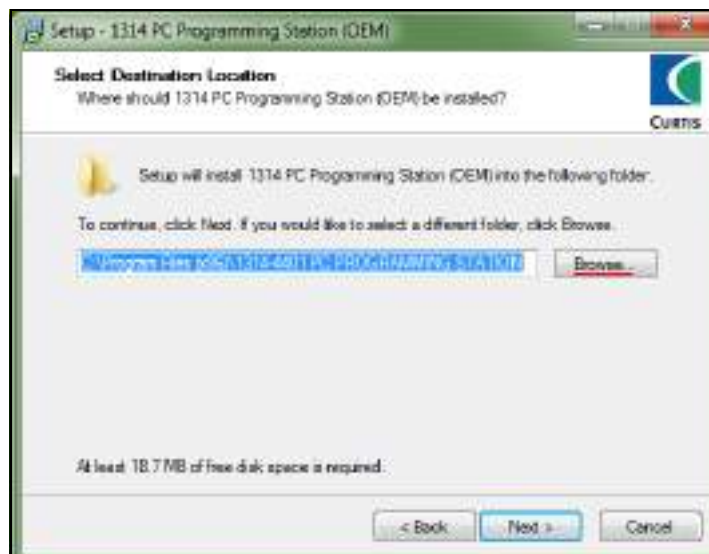

Figure 4-10: Destination Selection

6. Now hit [Install] to begin the process.

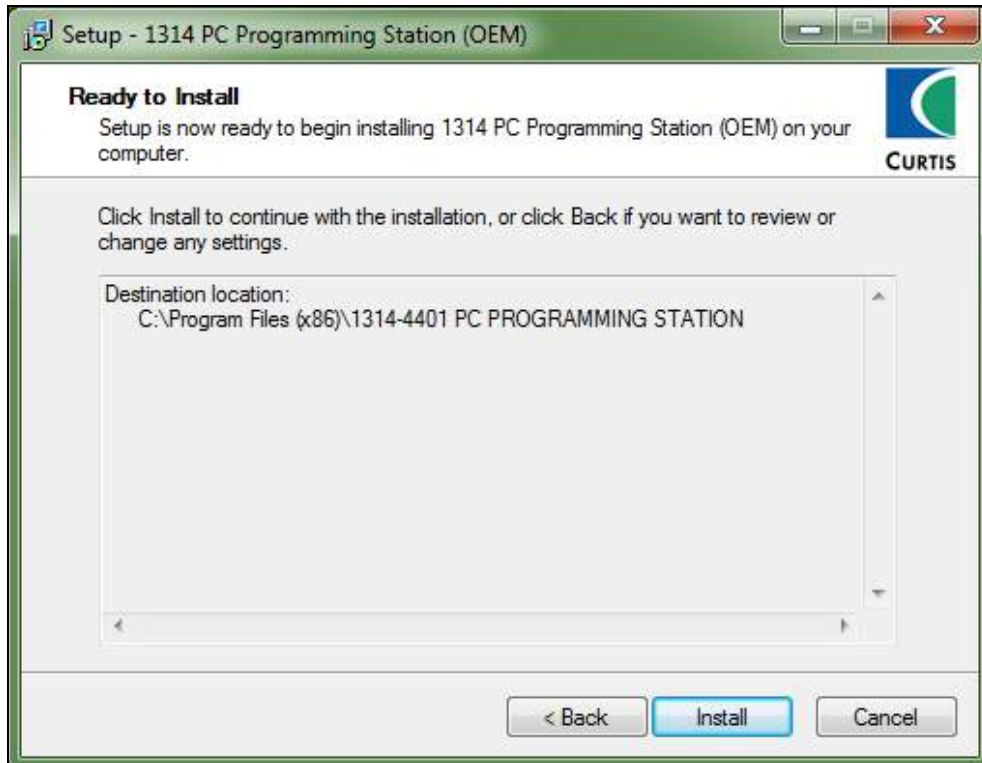

Figure 4-11: Ready to Install

7. If you see the screen in Figure 4-12, you have successfully installed the 1314 Curtis Program.

Click **[Finish]** to launch the program or uncheck the option beside "Run 1314 PC Programming Station" if you are not about to plug in and begin diagnosing.

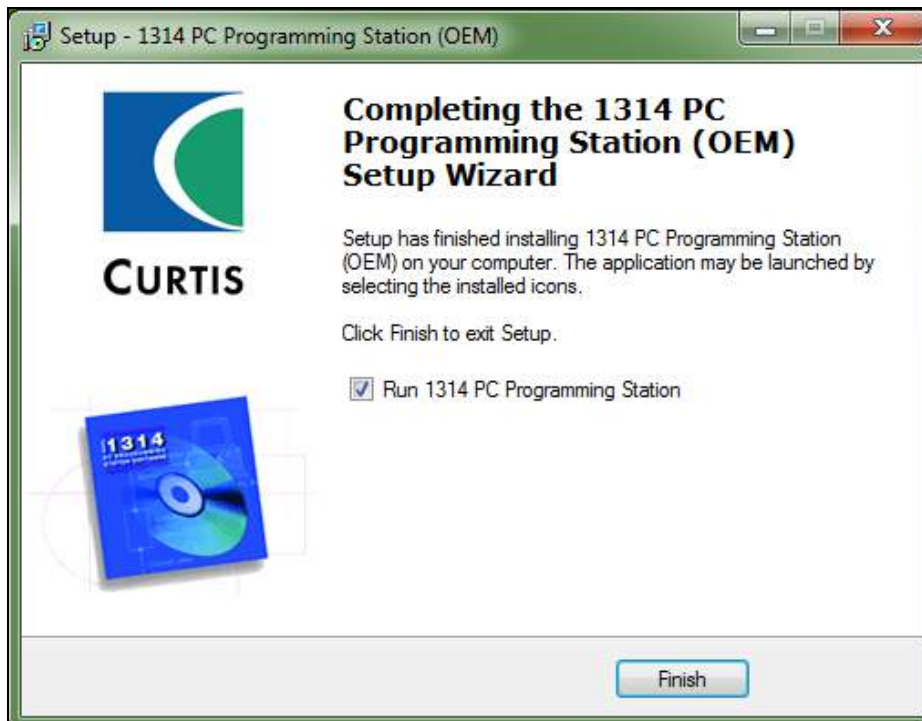

Figure 4-12: Successful Installation

1314 Update Procedure

NOTE

This procedure must be completed before using the software, on every installation of the software. See Figure 4-13.

1. Open the 1314 Software program and select "Help."
 2. Select the CHECK FOR UPDATES menu.
- This will use the internet to ensure that you have the latest revision level.

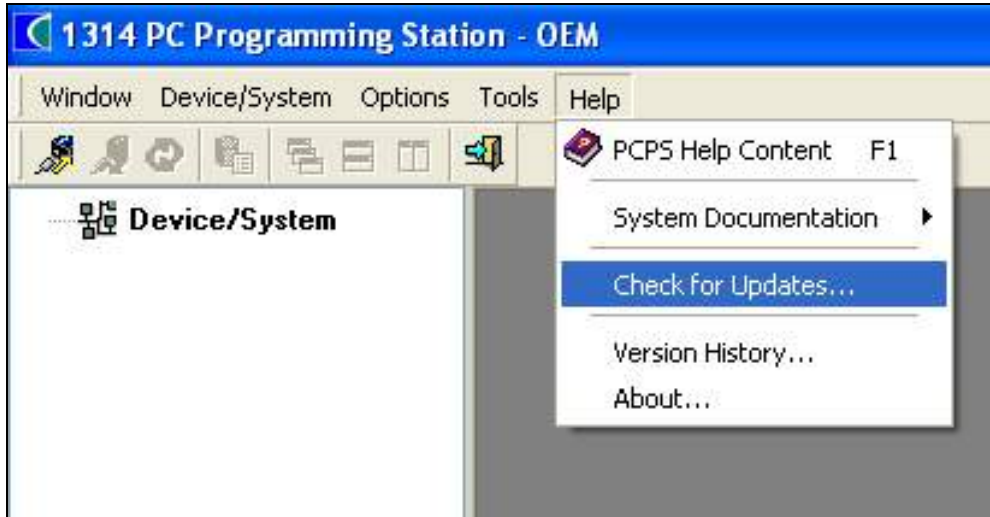

Figure 4-13: Update Procedure

Communicating with Bendi 55 AC Controllers

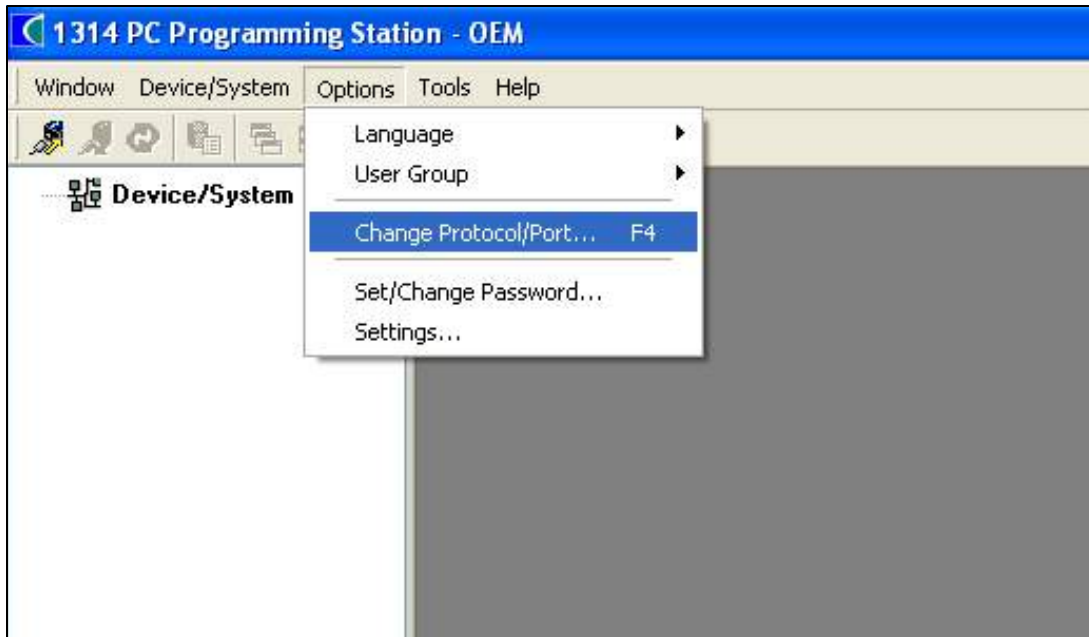

Figure 4-14: Communicating with the Controllers

To initiate communications with the Bendi Controllers, with the Curtis program open go to **Options**, then click **Change Protocol/Port**, as shown in Figure 4-14.

Select ENHANCED SERIAL protocol and then press the CONNECT button. This is shown in Figure 4-15, though the communication port number may differ from computer to computer.

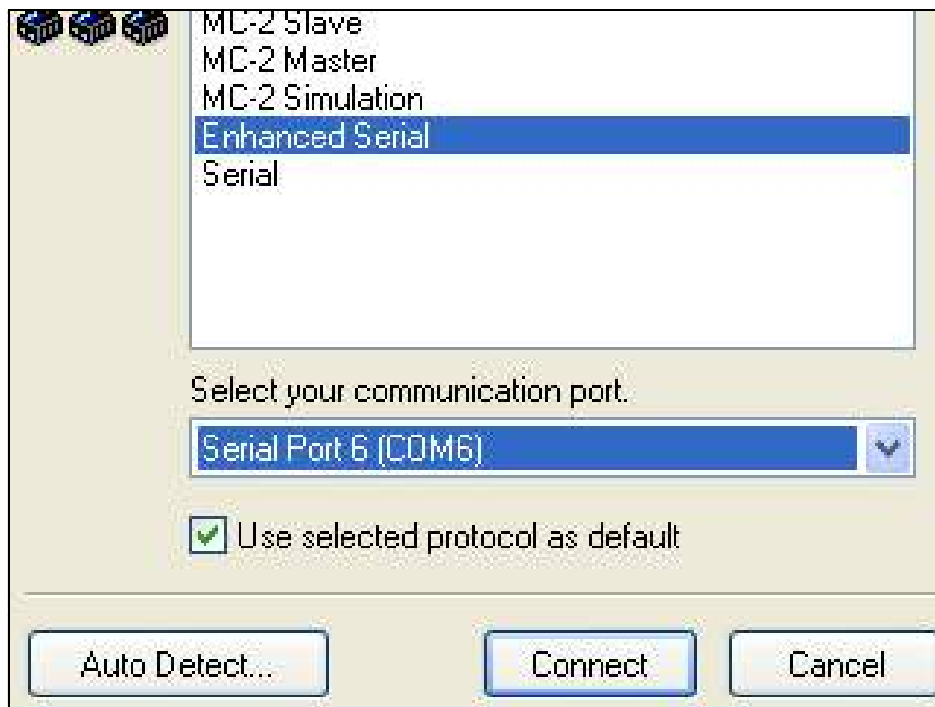

Figure 4-15: Selecting Protocol and Port

Highlight the connected controller and select the icon for Device Parameters, as shown in Figure 4-16. Once you've selected a parameter from the program tree you can adjust them in the active window.



Figure 4-16: Accessing Parameters

CALIBRATION & PROGRAMMING

The device may be monitored by clicking on the MONITOR button. The monitor function is useful to see actual controller values during operation of the truck.

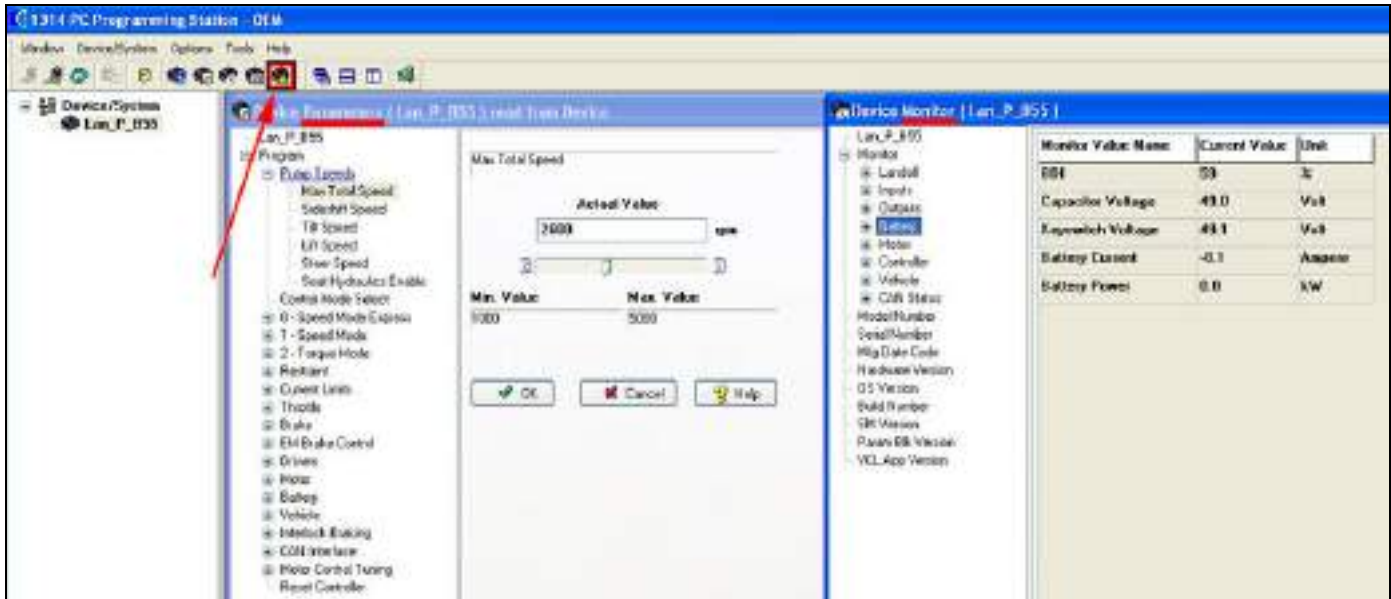

Figure 4-17: Accessing the Monitor

Controller Fault History

The 1314 programmer can be used to access the controller's fault history file. The programmer will read out all the faults the controller has experienced since the last time the fault history file was cleared. Faults such as contactor faults may be the result of loose wires; contactor wiring should be carefully checked. Faults such as over temperature may be caused by operator habits or by overloading. After a problem has been diagnosed and corrected, it is a good idea to clear the fault history file. This allows the controller to accumulate a new file of faults. By checking the new fault history file at a later date you can readily determine whether the problem was indeed fixed.

You may now begin to manipulate, monitor and diagnose the forklift performance and functionality.

1314 Software has many built-in features to help in troubleshooting individual controllers. Click on the Exclamation point icon and select the desired option as shown in Figure 4-18.

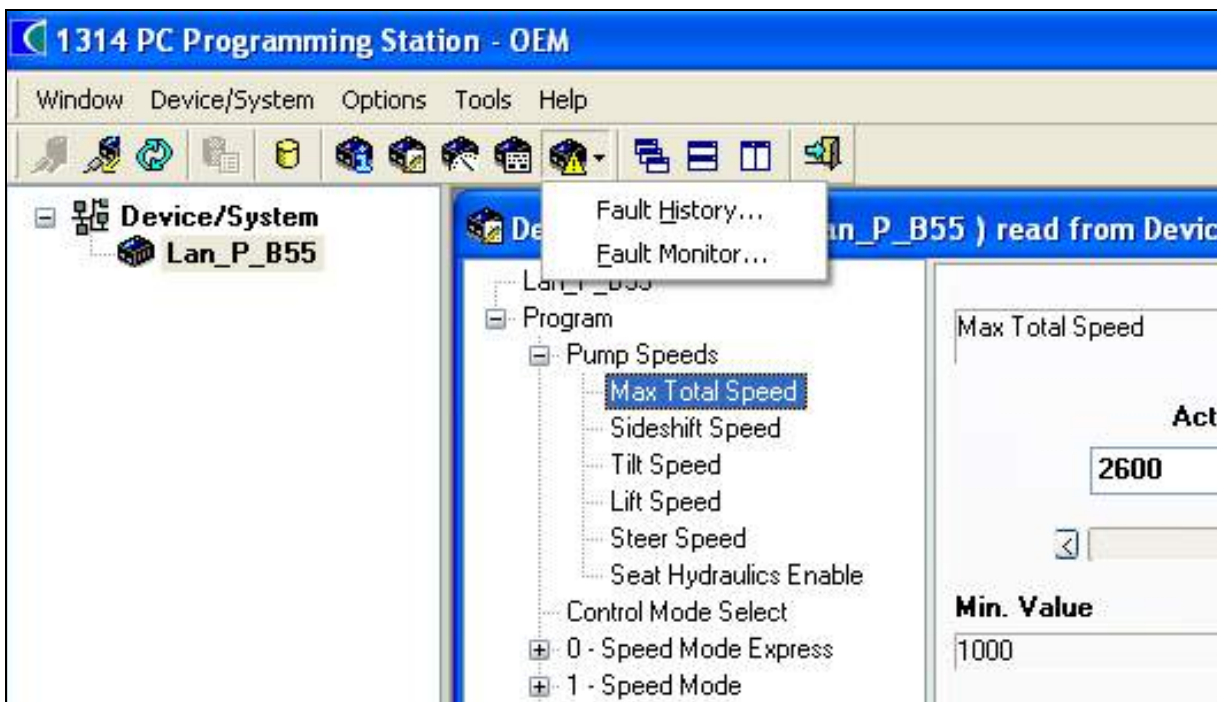

Figure 4-18: Fault Monitor

Individual faults in FAULT HISTORY are cleared by highlighting the fault and RIGHT clicking it. A drop down menu will give you the option to clear the fault as shown in the example below.

IMPORTANT

After successfully re-flashing a controller, make sure to clear the fault history of all comments.



Figure 4-19: Fault History

Familiarizing the Menus

See Figure 4-20 for the following:

Number 1 in Figure 4-20 shows the Disconnect Icon.

Number 2 shows, from left to right, Device Info, Device Parameters, Device Functions, Diagnose and Fault History.

Number 3 shows the controller currently connected. DD_M is Master Controller, DD_S is Slave Controller, and P_B55 is Pump Controller.

Program's Menus

There are five menus, which in turn lead to nested submenus.

- **Information** — displays data about the host controller, model and serial numbers, date of manufacture, hardware and software revisions, and itemization of other devices that may be associated with the controller's operation.
- **Parameters** — provides access to the programmable parameters.
- **Functions** — provides access to the controller-cloning commands and to the "reset" command.
- **Monitor** — presents real-time values during vehicle operation; these include all inputs and outputs, as well as the mapped throttle values and conditioned throttle requests.
- **Faults** — presents diagnostic information and also a means to clear the fault history file.



Figure 4-20: Devices Info

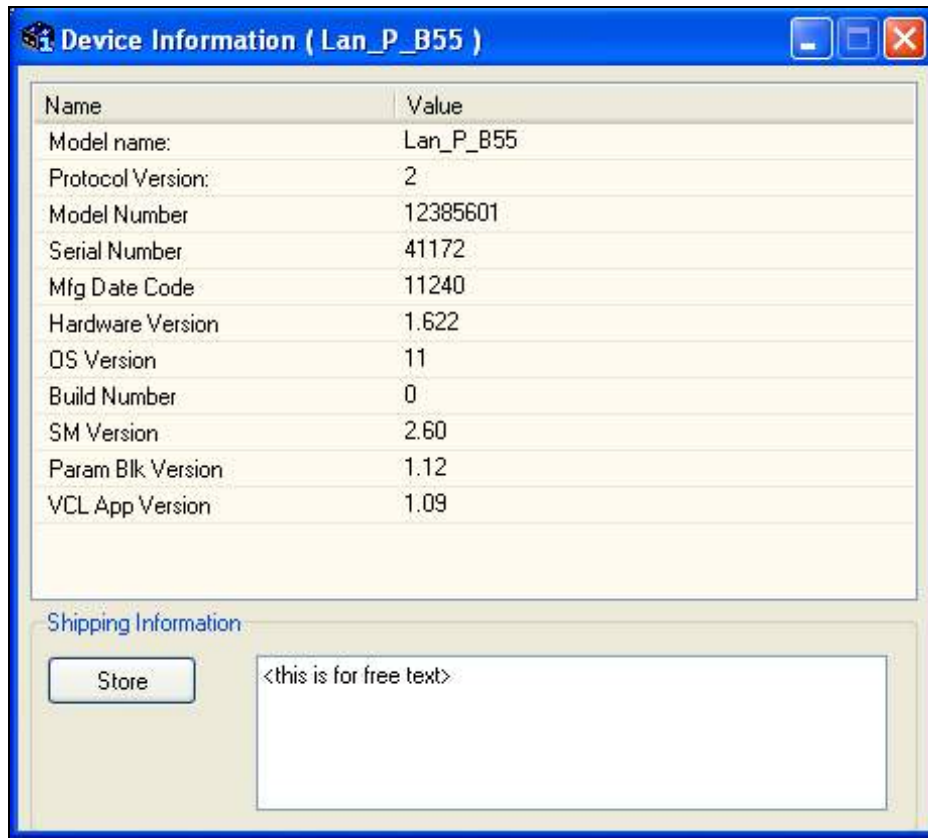

Figure 4-21: Software Revisions

IMPORTANT

Contact Landoll for Current Software Revision. See Figure 4-21.

NOTE

See Figures 4-22 thru 4-59. After successfully connecting to the controller, proceed through the instructed menus and sub-menus to review all parameters.

For All Parameters:

To change actual value to a desired value, click in the white text field or use the slider just underneath. When complete, click OK to change value.

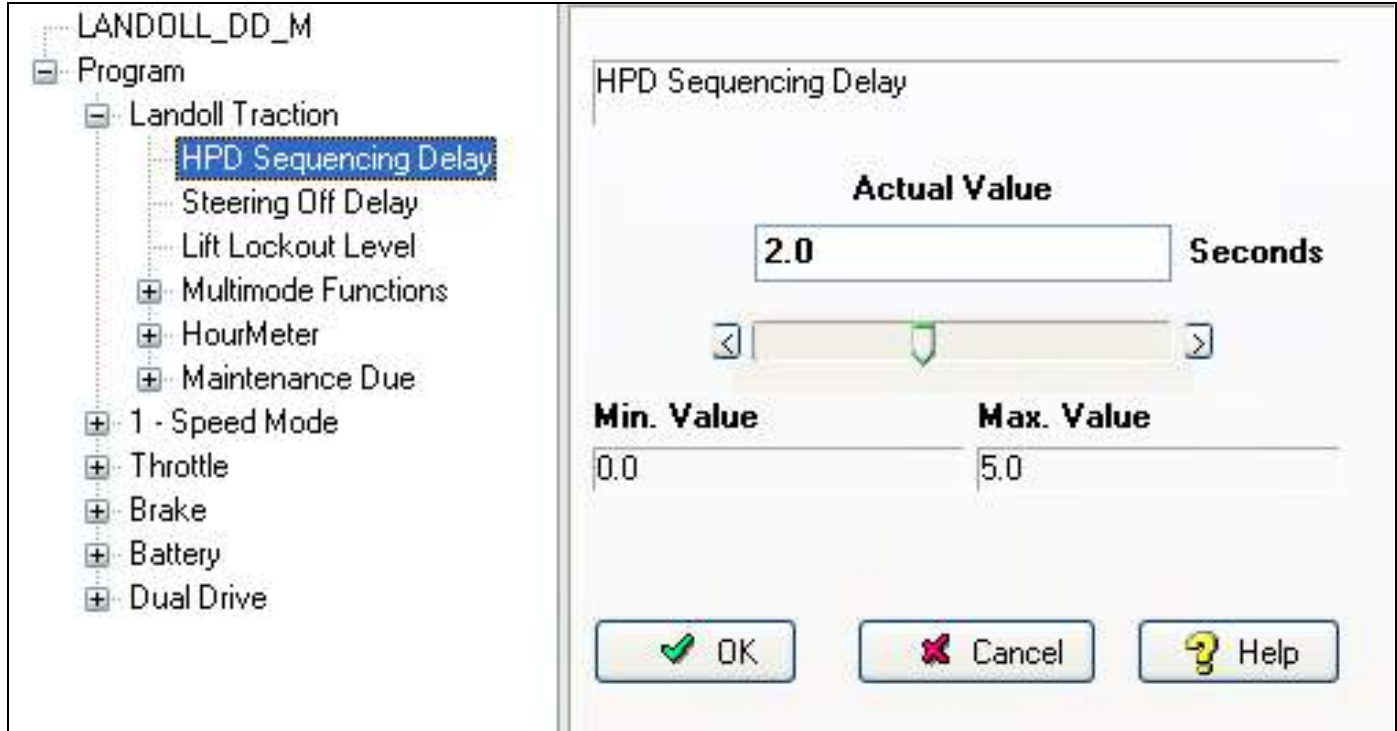

Figure 4-22: HPD Sequencing Delay - 1 of 2

HPD Sequencing Delay: Actual Value shows current duration the seat switch can be false until SRO (return to neutral) occurs.

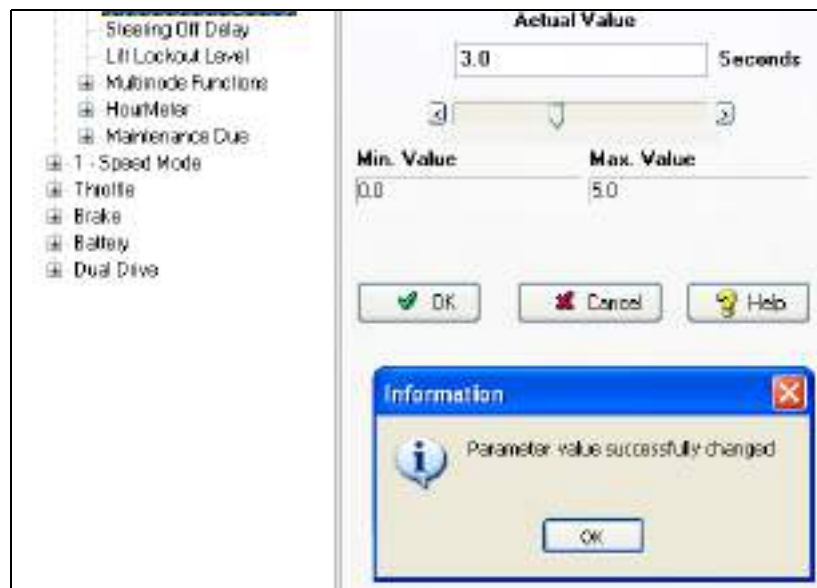

Figure 4-23: HPD Sequencing Delay - 2 of 2

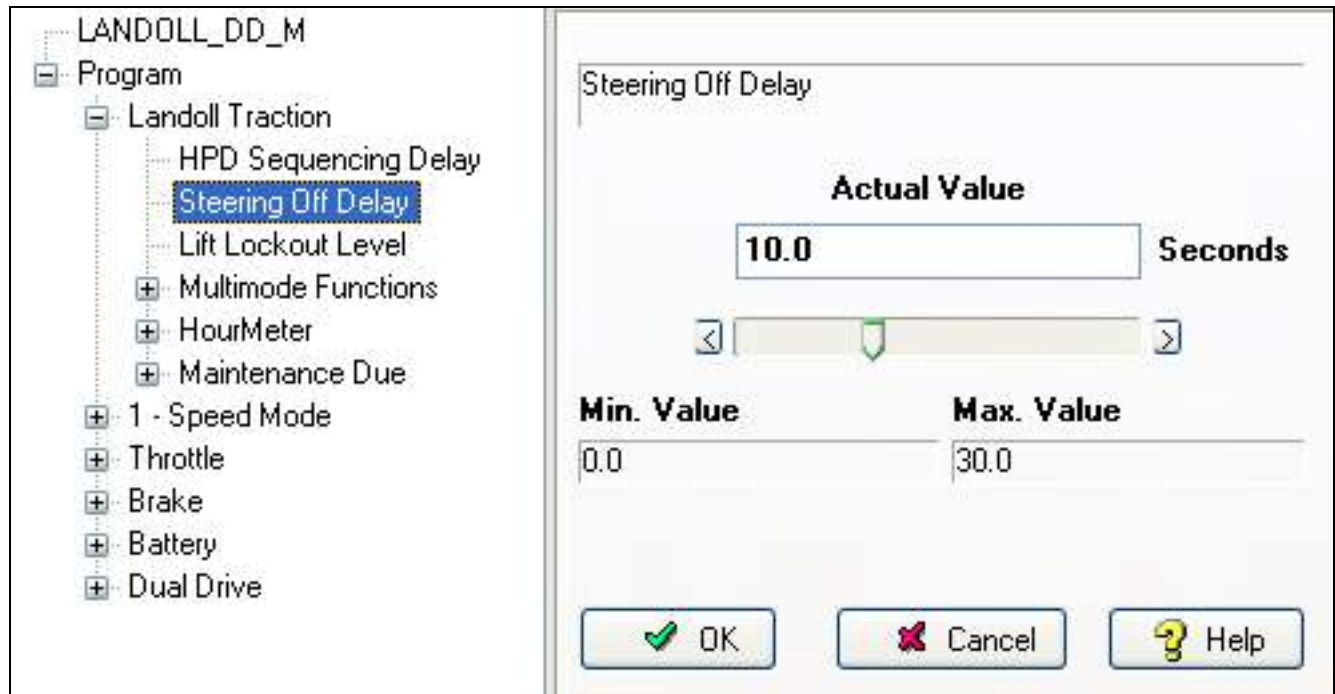

Figure 4-24: Steering Off Delay

Steering Off Delay: Sets the time the pump will continue to run after the seat switch input goes false (no operator's presence).

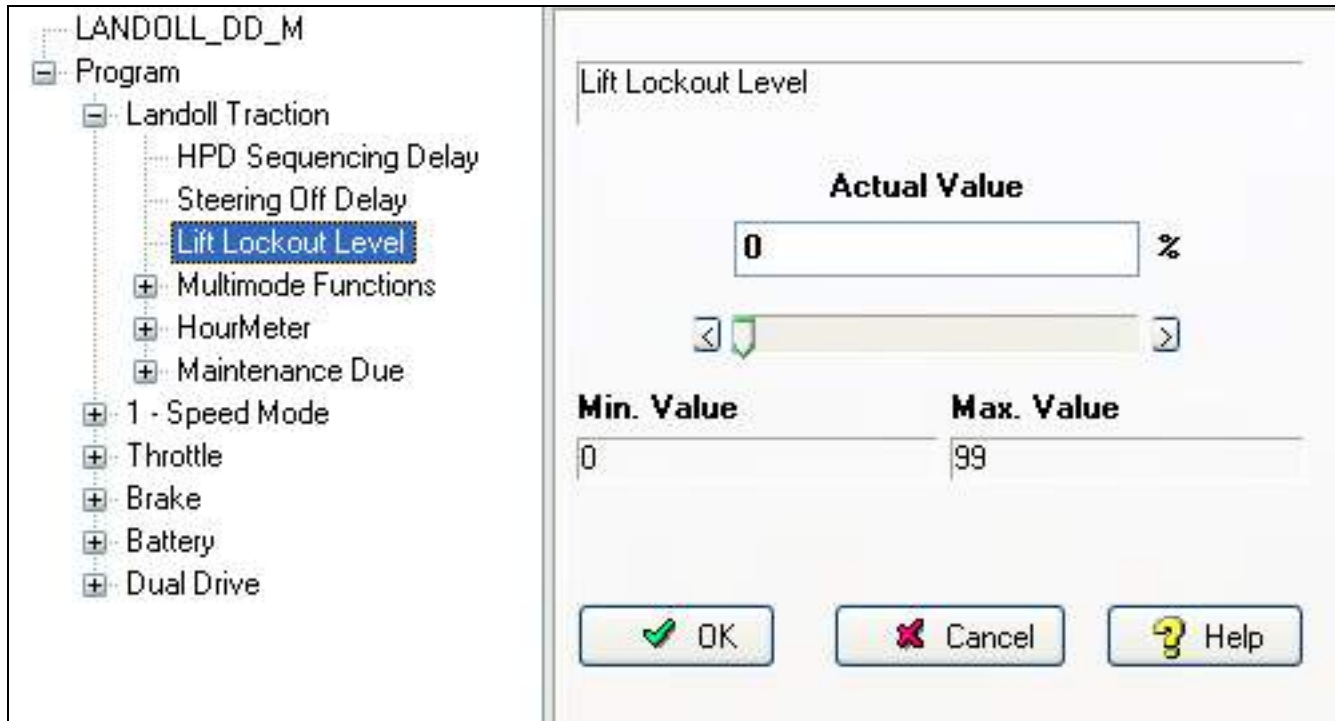

Figure 4-25: Lift Lockout Level

Lift Lockout Level: Sets the percentage of battery discharge before lift lockout occurs. This protects the operator from running the battery below a safe level.

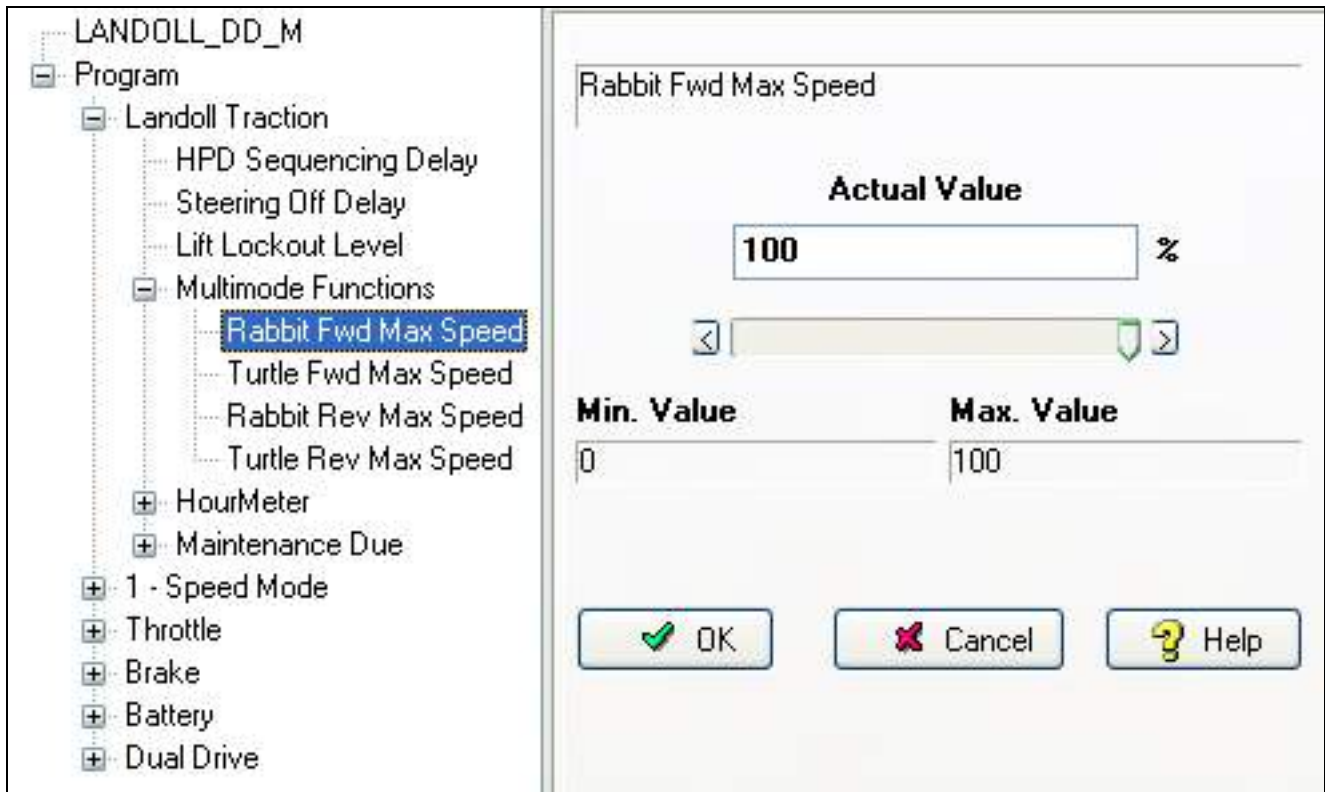

Figure 4-26: Rabbit Fwd Max Speed

Rabbit Forward Maximum Speed: Sets the Forward vehicle max speed in Rabbit Mode.

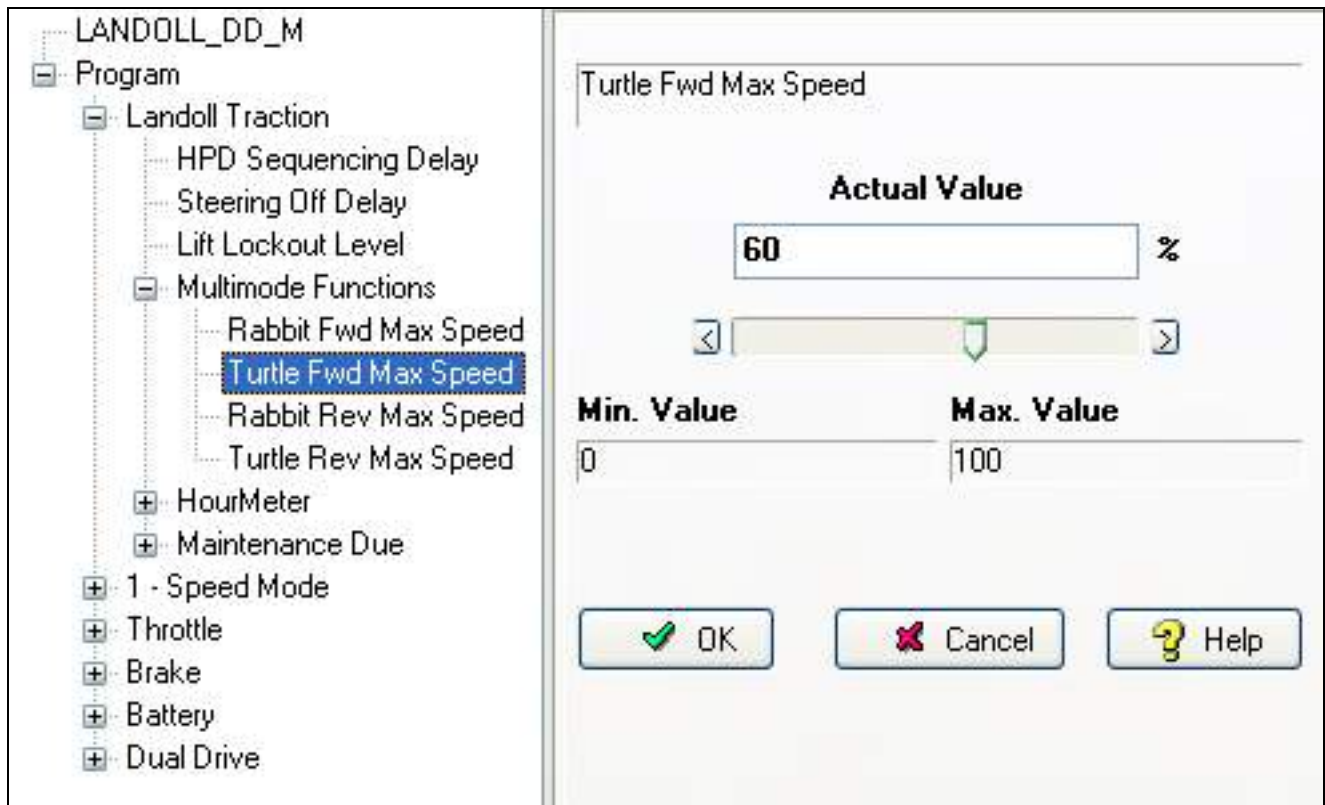

Figure 4-27: Turtle Fwd Max Speed

Turtle Forward Maximum Speed: Sets the Forward vehicle max speed in Turtle Mode.

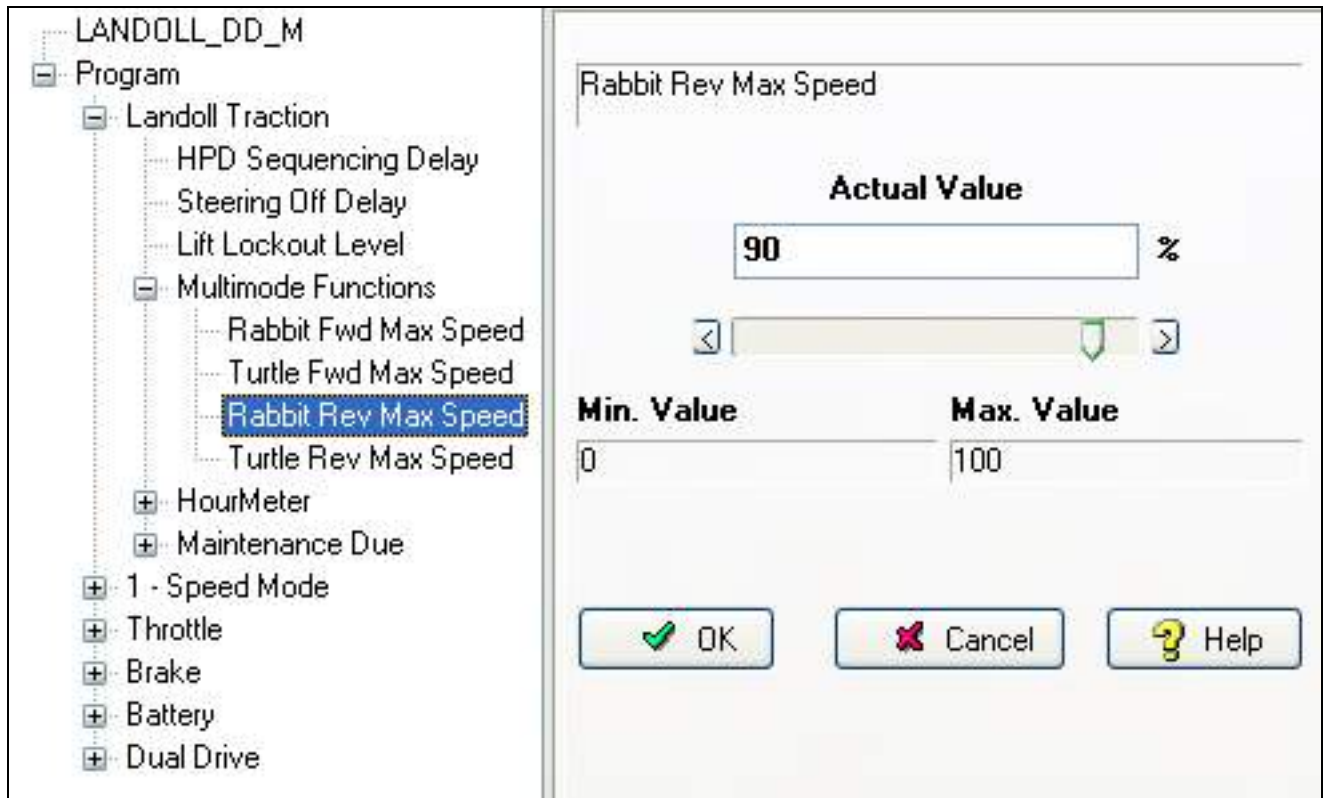

Figure 4-28: Rabbit Rev Max Speed

Rabbit Reverse Maximum Speed: Sets the Reverse vehicle max speed in Rabbit Mode.

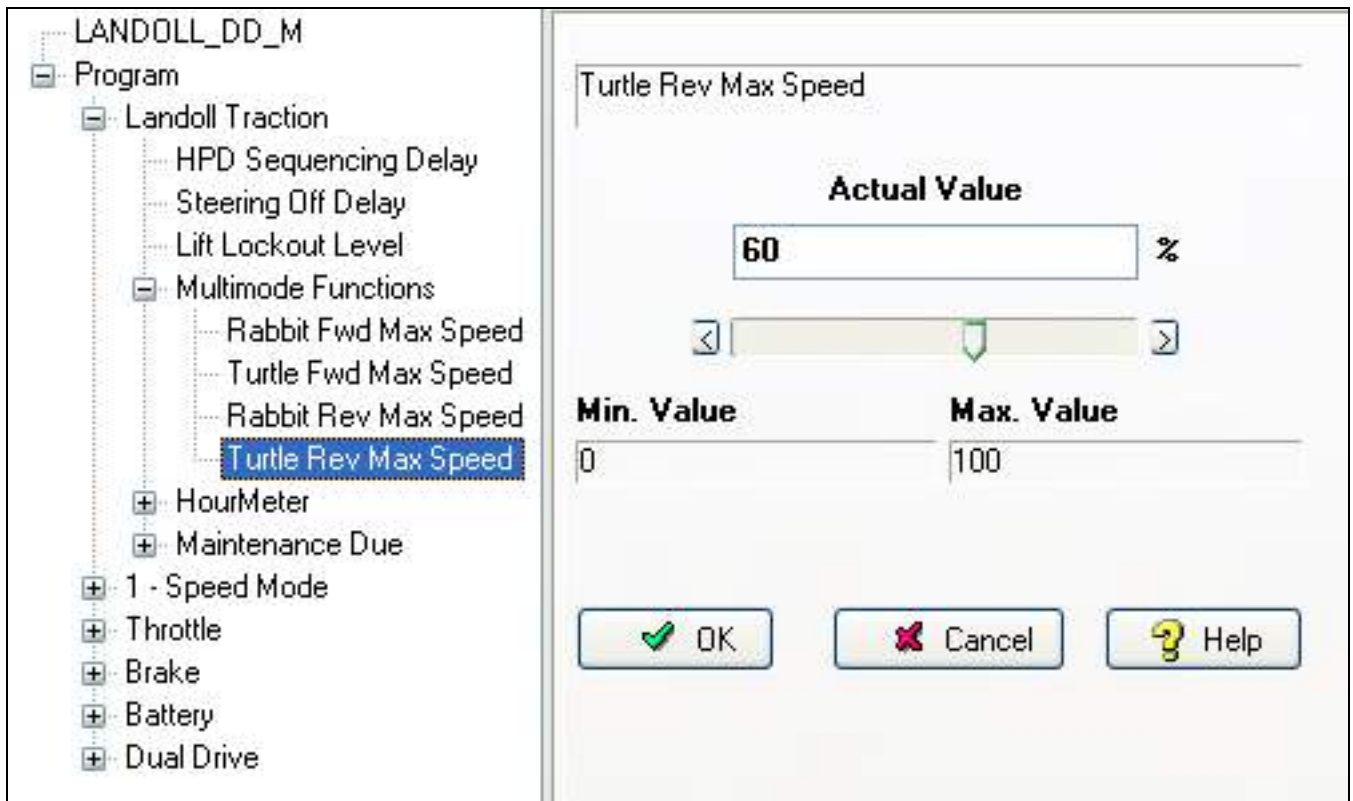

Figure 4-29: Turtle Rev Max Speed

Turtle Reverse Maximum Speed: Sets the Reverse vehicle max speed in Turtle Mode.

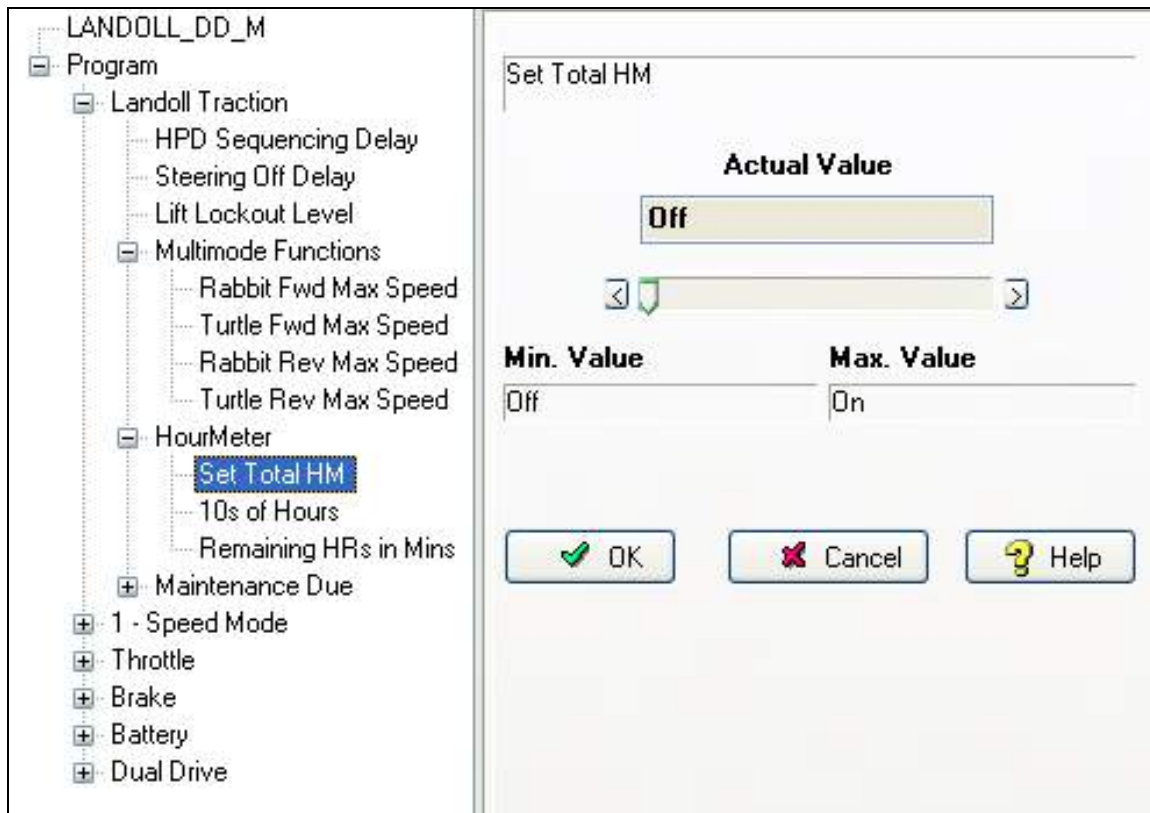

Figure 4-30: Set Total HM

Set Total Hours/Minutes: When set to On, values entered in “10’s of Hours” and “Remaining Hrs in Mins” are sent to the controller.

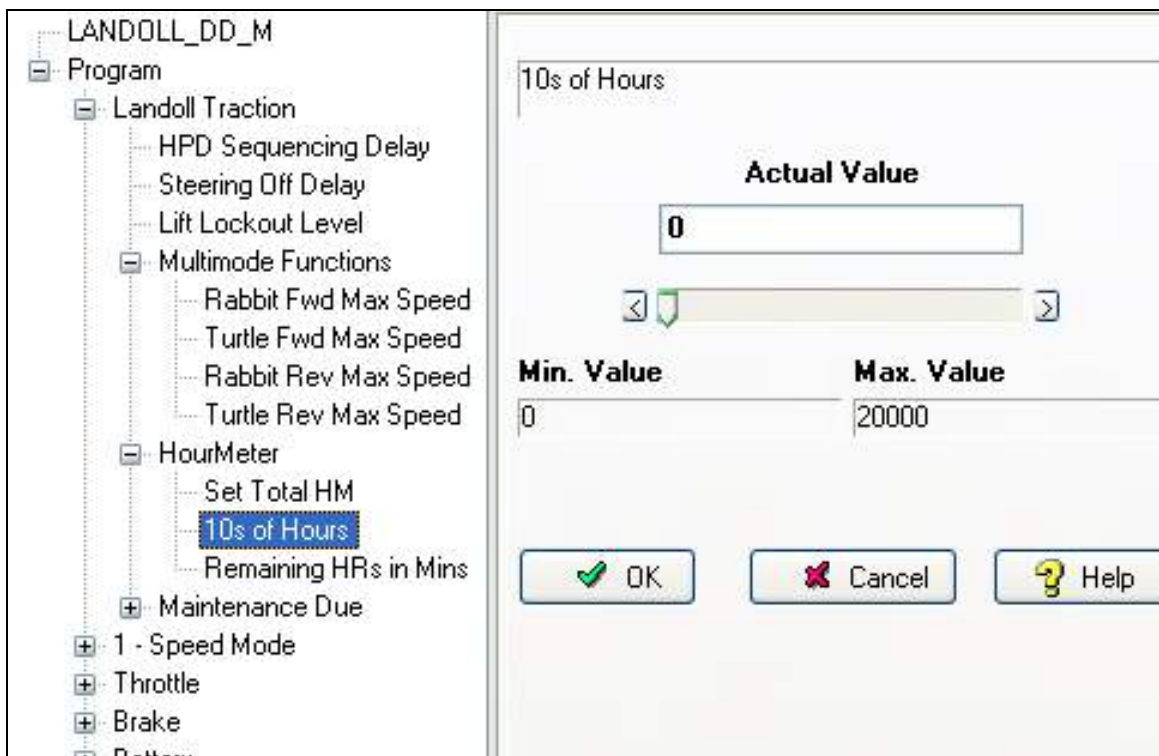

Figure 4-31: 10s of Hours

10’s of Hours: Sets number of 10 shown on the Hourmeter in increments of 10. Ex: Actual Value of 150 = 1500 Hours.

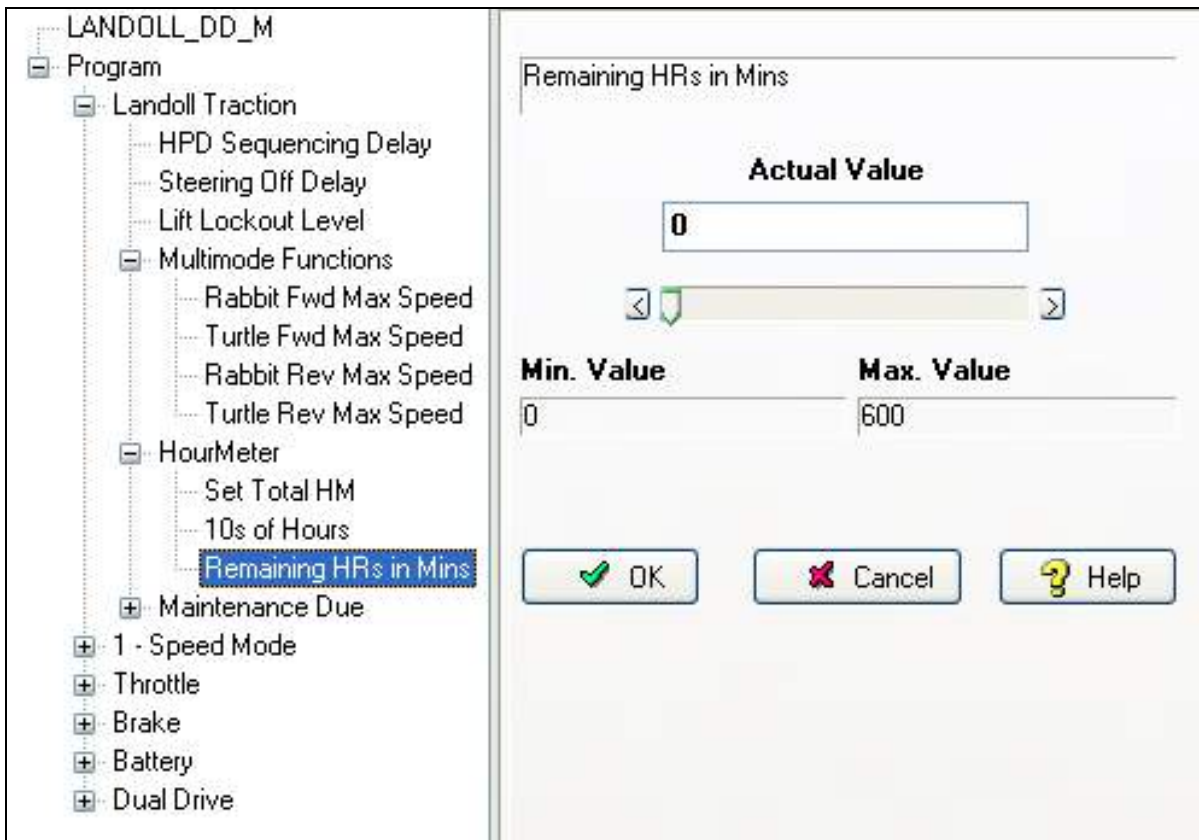

Figure 4-32: Remaining HRs in Mins

Remaining Hours in Minutes: Sets remaining number of hours besides those shown in “10’s of Hrs.” Ex: Actual Value of 390 = 6.5 hours

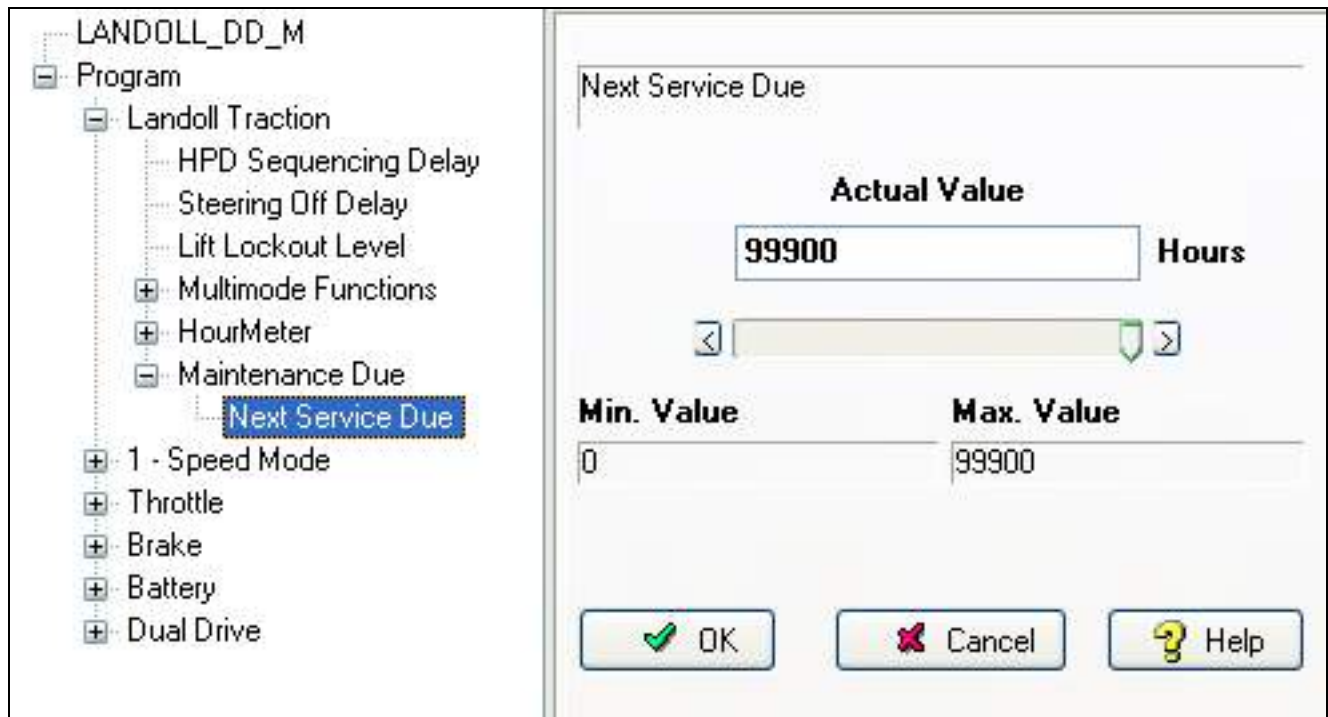

Figure 4-33: Next Service Due

Next Service Due: Sets when “Service Due” will be shown on the Dash Display. Can be set, defaulted at 99900 hours.

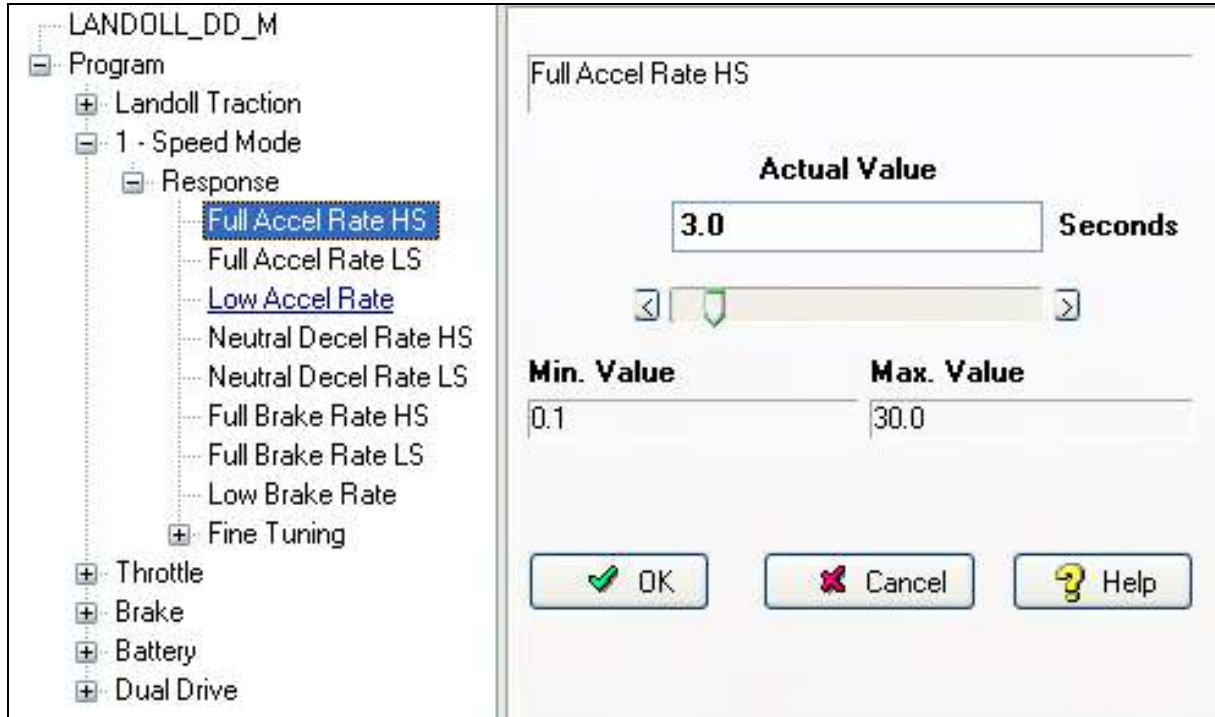

Figure 4-34: Full Accel Rate HS

Full Acceleration Rate, High Speed: The rate of which speed command increases when full throttle is applied at high speeds.

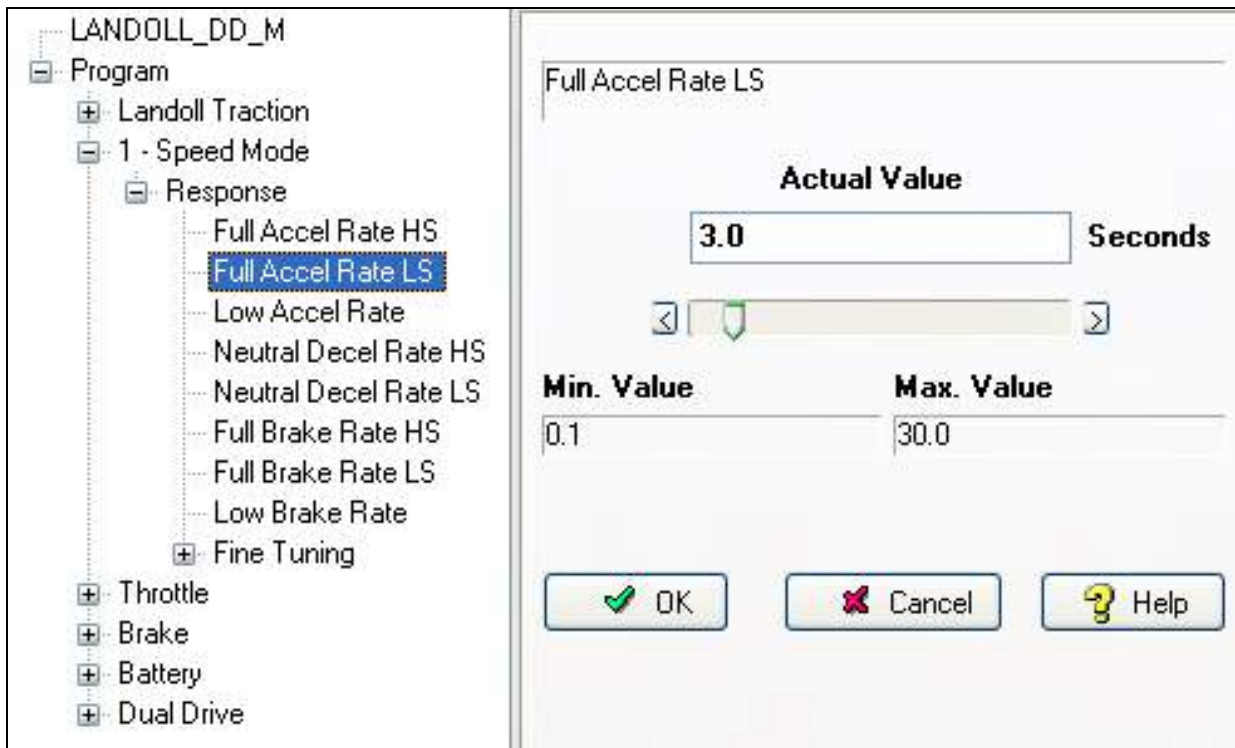

Figure 4-35: Full Accel Rate LS

Full Acceleration Rate, Low Speed: The rate of which speed command increases when full throttle is applied at low speeds.

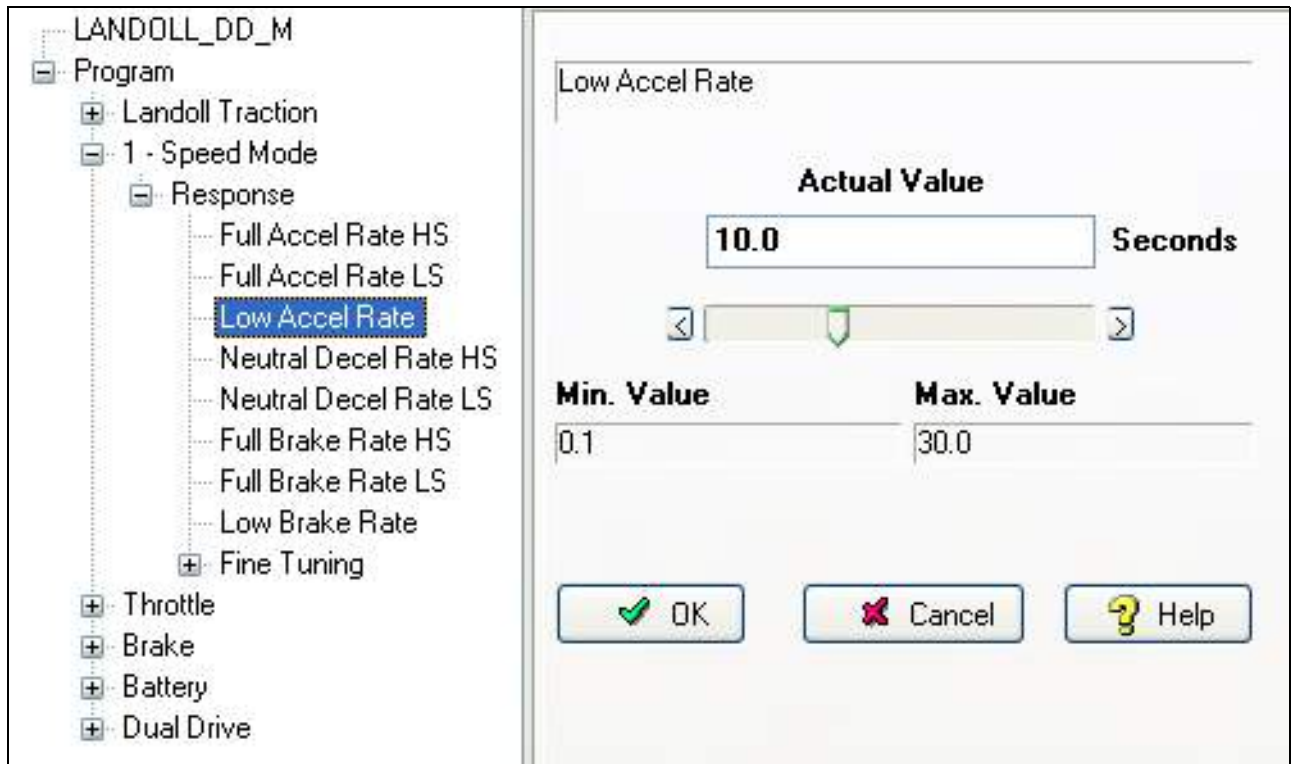

Figure 4-36: Low Accel Rate

Low Acceleration Rate: Sets the rate at which the speed command increases when a small amount of throttle is applied. Typically adjusts low speed control.

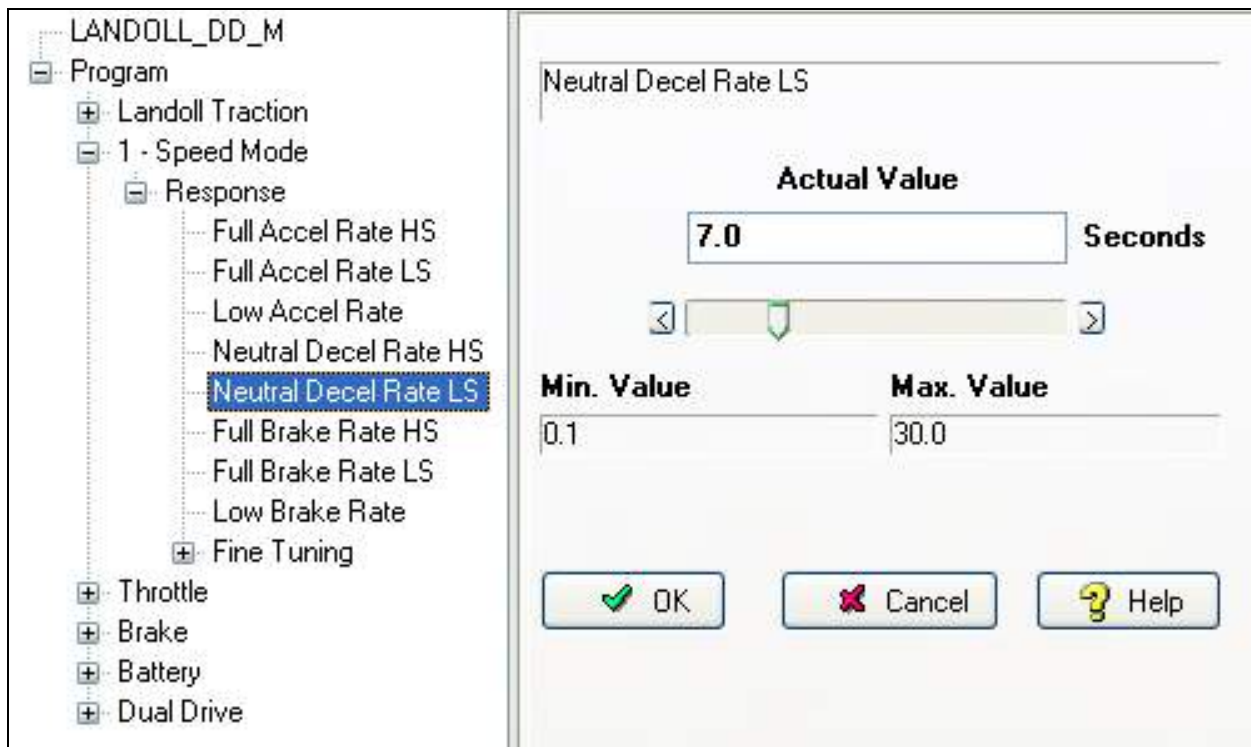

Figure 4-37: Neutral Decel Rate HS

Neutral Deceleration Rate, High Speed: Sets the rate that slows down the vehicle when the throttle is release to neutral at high vehicle speeds.

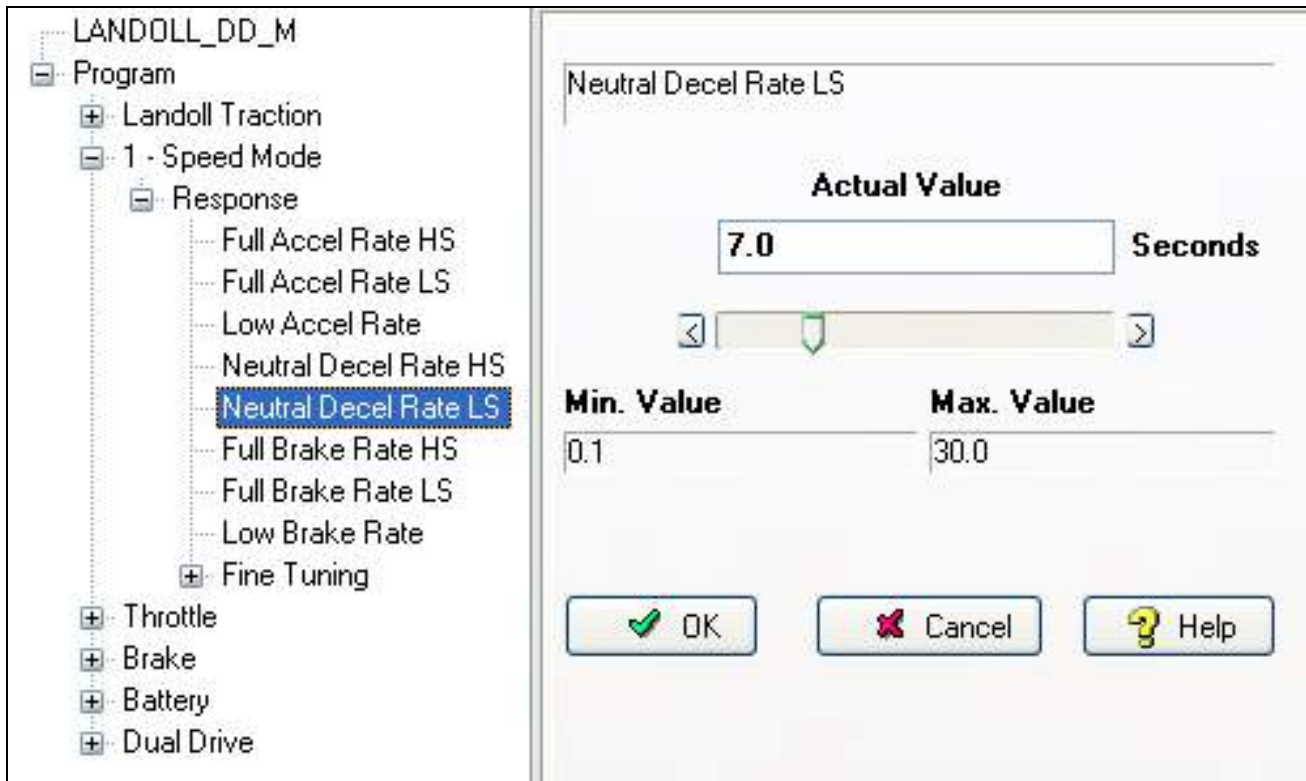

Figure 4-38: Neutral Decel Rate LS

Neutral Deceleration Rate, Low Speed: Sets the rate that slows down the vehicle when the throttle is released to neutral at slow vehicle speeds.

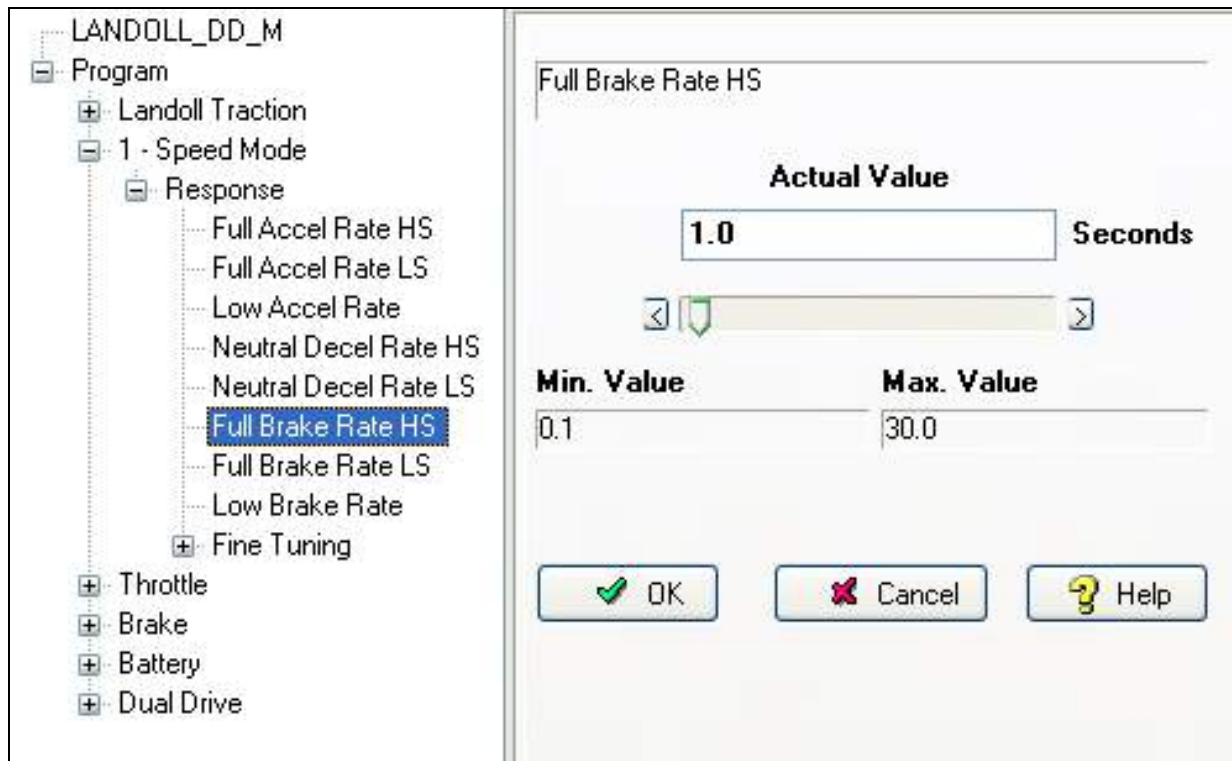

Figure 4-39: Full Brake Rate HS

Full Braking Rate, High Speed: Sets the rate at which the vehicle slows down from high speeds when full brake is applied or when full throttle is applied in the opposite direction.

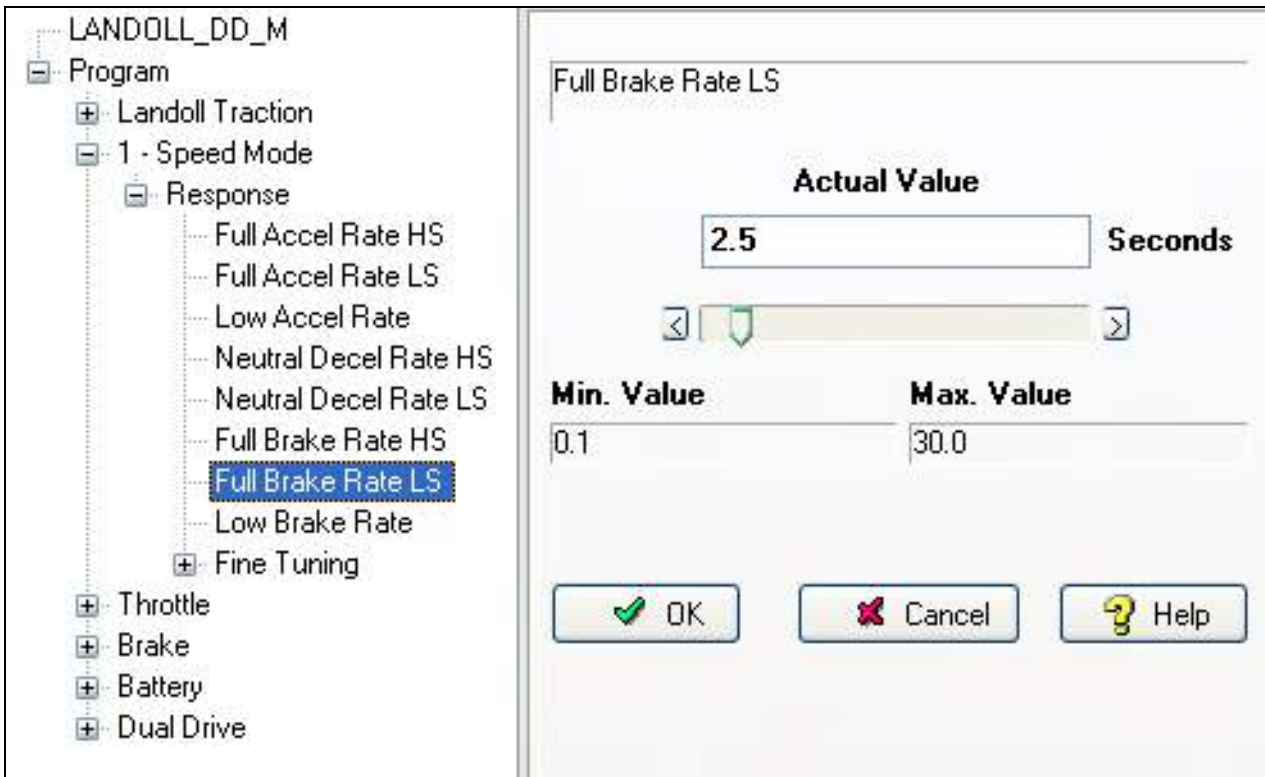

Figure 4-40: Full Brake Rate LS

Full Braking Rate, Low Speed: Sets the rate at which the vehicle slows down from slow speeds when full brake is applied or when full throttle is applied in the opposite direction.

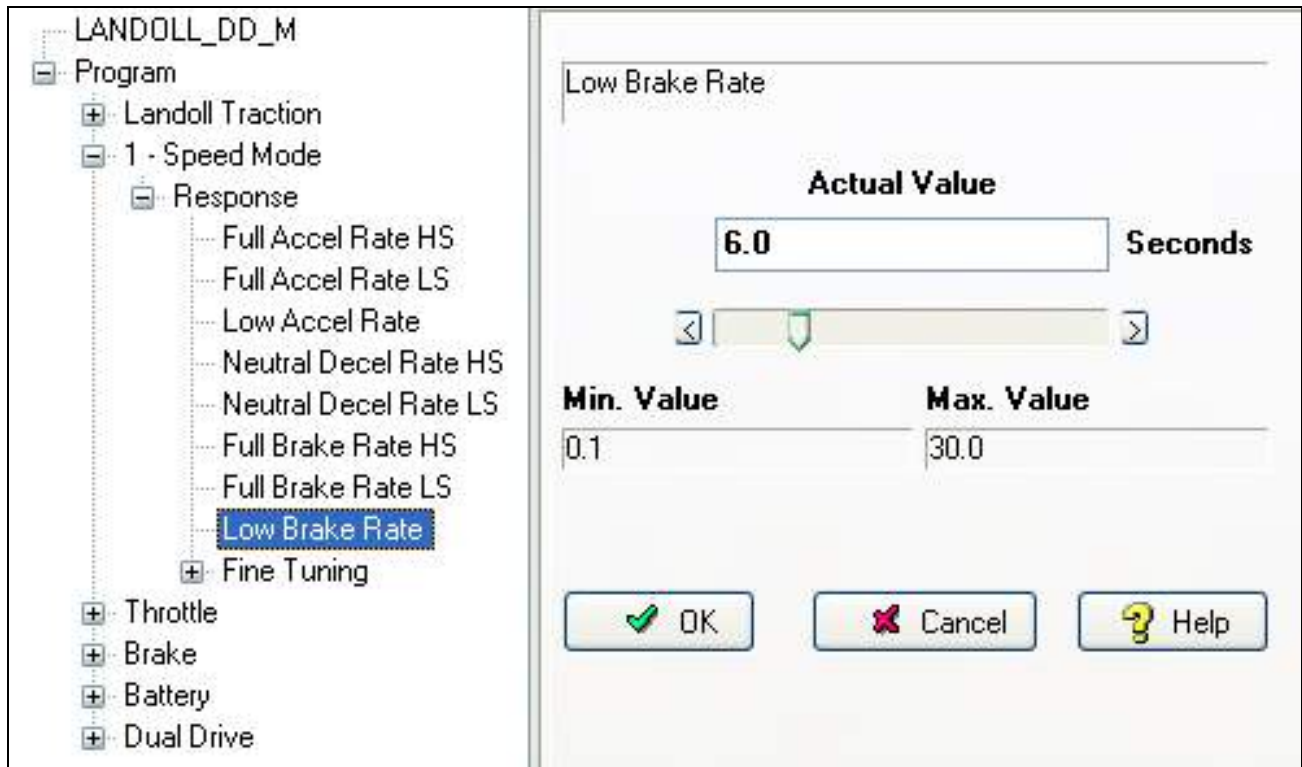

Figure 4-41: Low Brake Rate

Low Braking Rate: Sets the rate at which the vehicle slows down at all speeds when a small amount of brake is applied or a small amount of throttle is applied in the opposite direction.

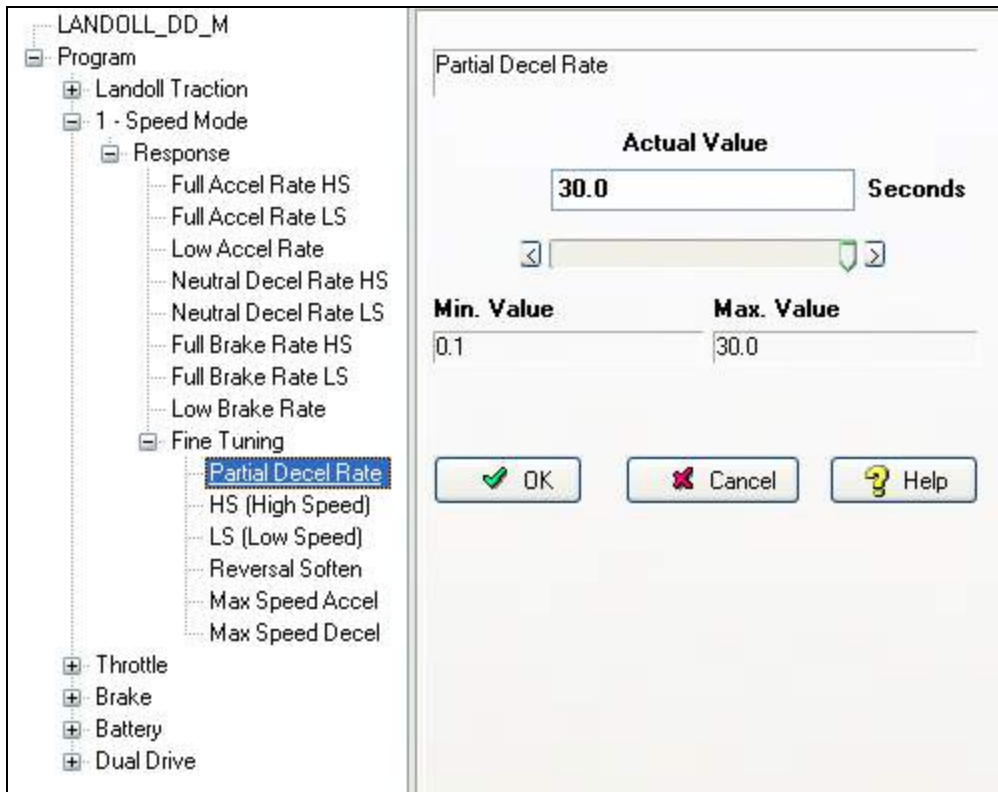

Figure 4-42: Partial Decel Rate

Partial Deceleration Rate: Sets the rate that is used to slow down the vehicle when the throttle is reduced without being released to neutral.

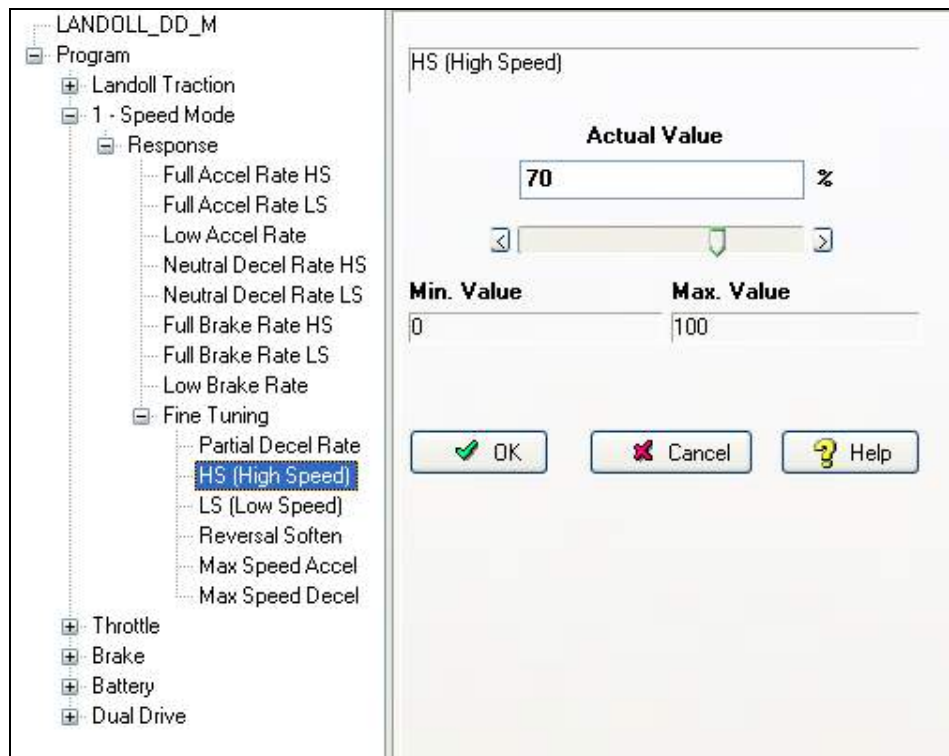

Figure 4-43: HS (High Speed)

HS (High Speed): Sets the percentage of the Typical Max Speed above which the “HS” parameters will be used.

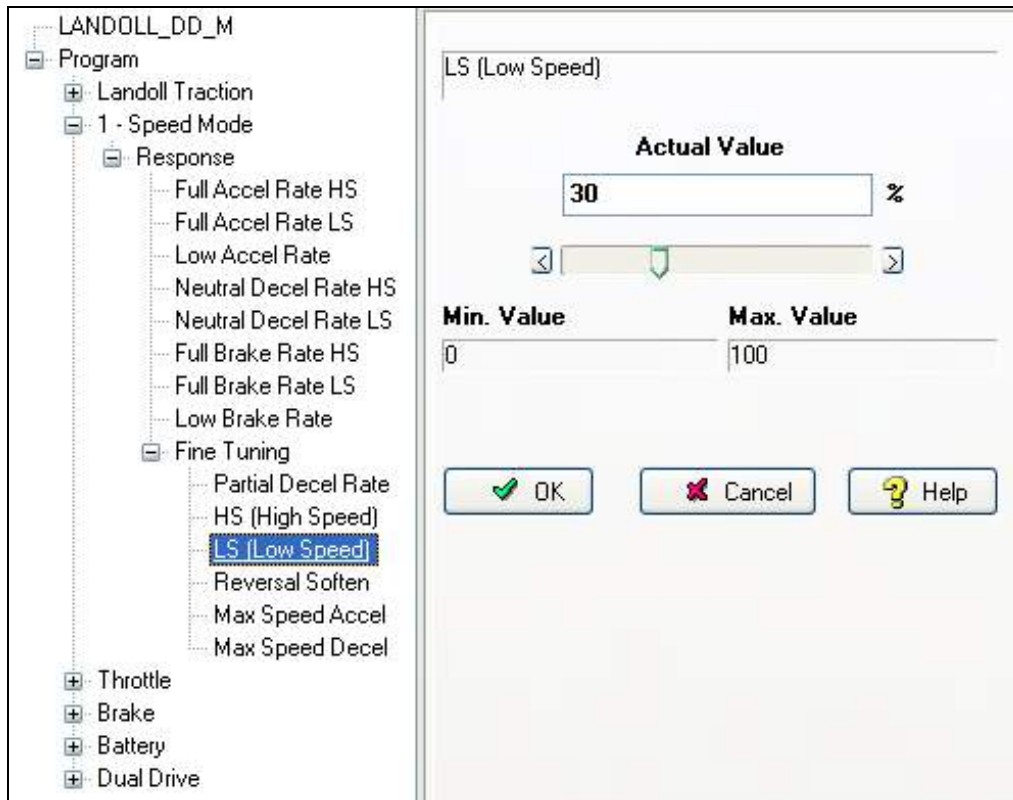

Figure 4-44: LS (Low Speed)

LS (Low Speed): Sets the percentage of the Typical Max Speed below which the “LS” parameters will be used.

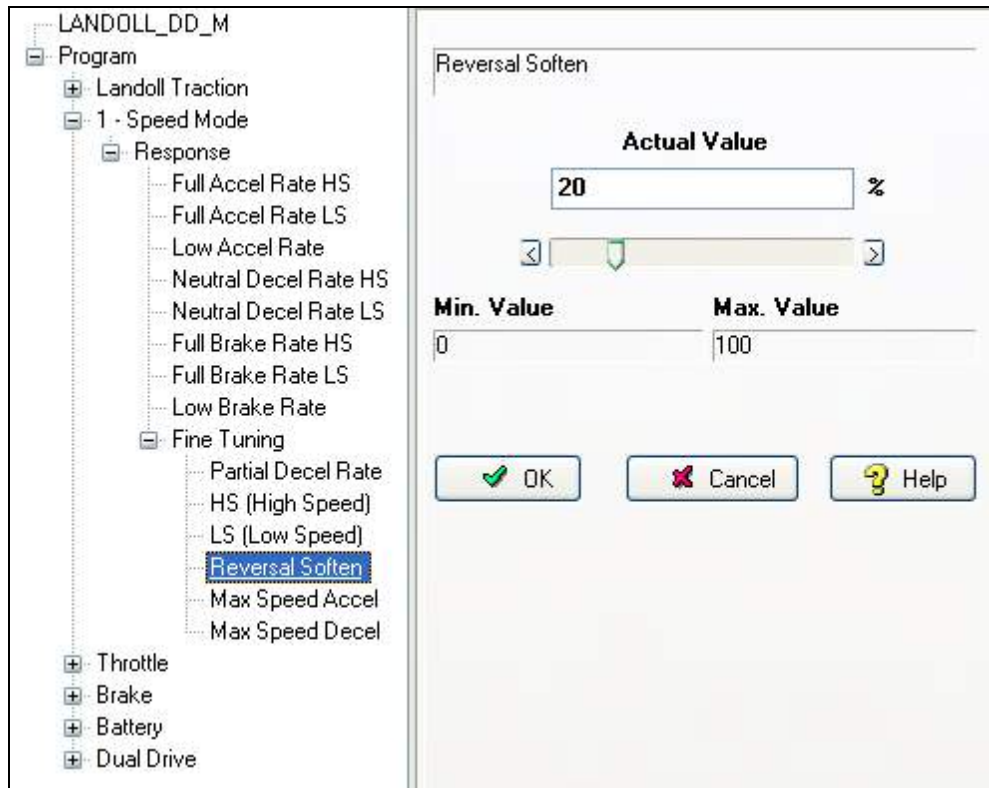

Figure 4-45: Reversal Soften

Reversal Soften: Larger values create a softer reversal from regen braking to drive when near zero speed.

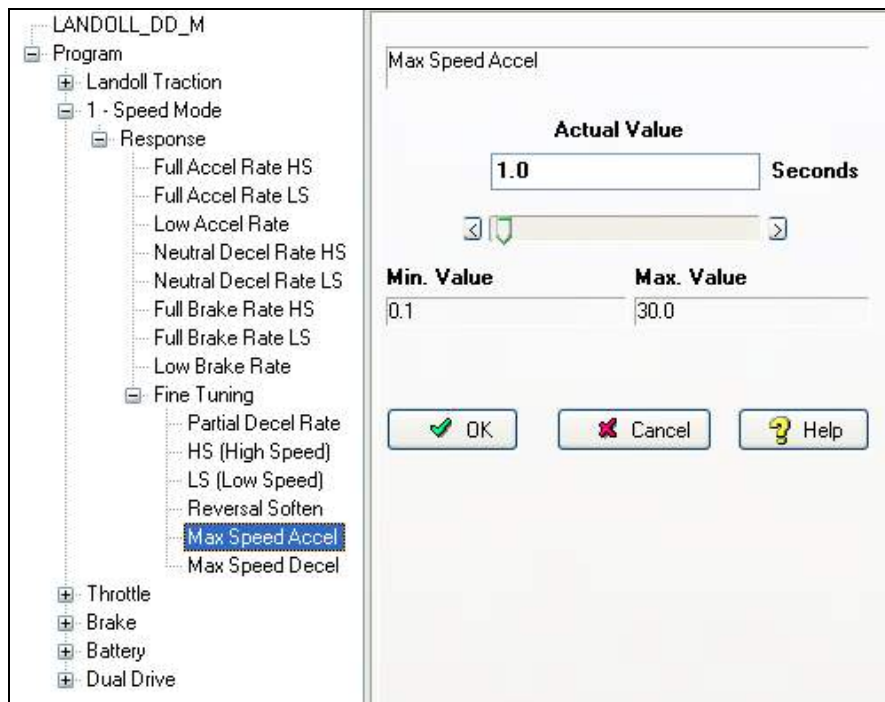

Figure 4-46: Max Speed Accel

Maximum Speed Acceleration: This parameter controls the rate at which the maximum speed setpoint is allowed to change when the value of Max Speed is raised.

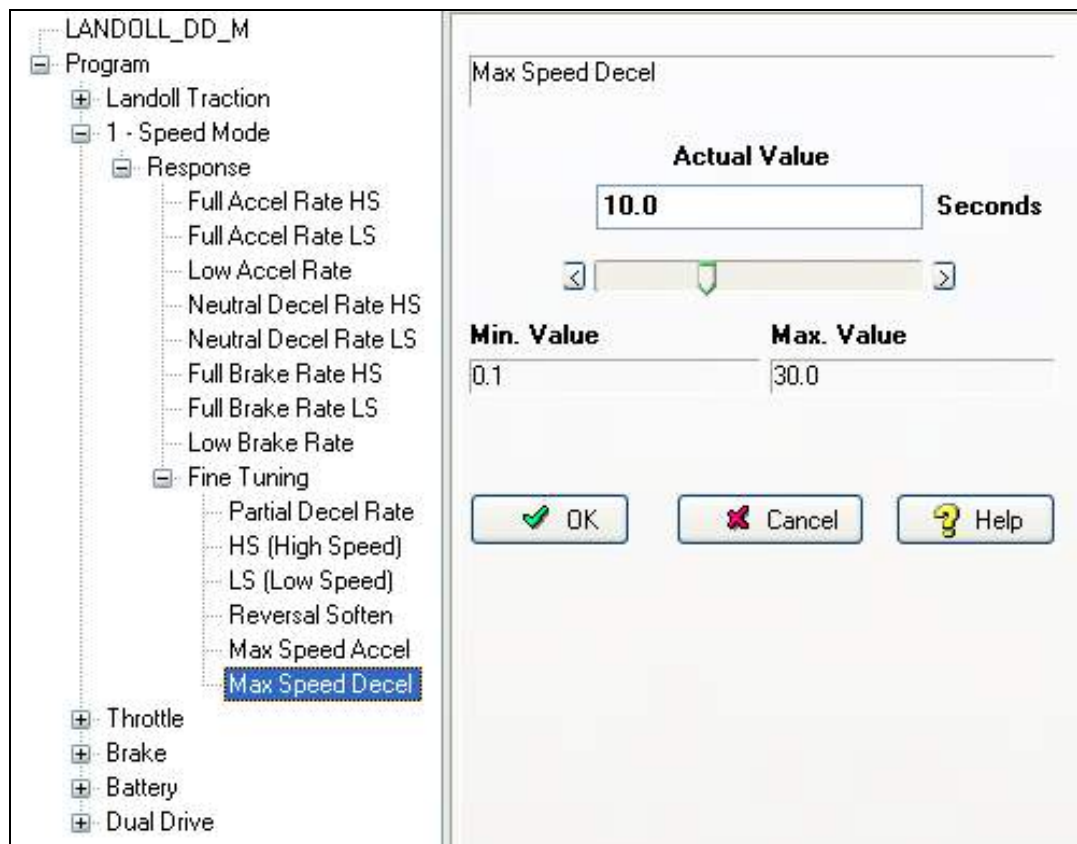

Figure 4-47: Max Speed Decel

Maximum Speed Deceleration: This parameter controls the rate at which the maximum speed set point is allowed to change when the value of Max Speed is lowered.

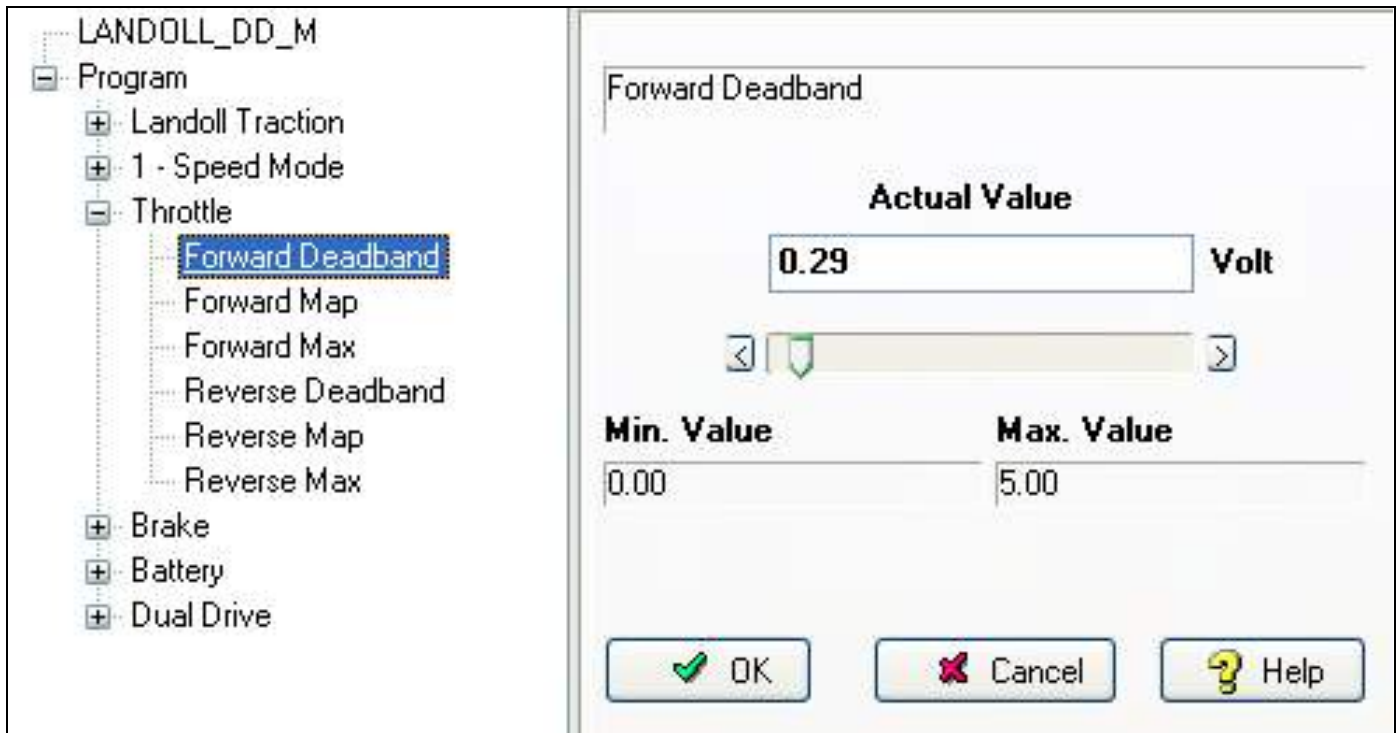

Figure 4-48: Forward Deadband

Forward Deadband: The value when the accelerator is not being depressed. Using the Monitor Menu, add .10 to the value shown for the Throttle Pot to get the appropriate value for this parameter. Should match Reverse Deadband.

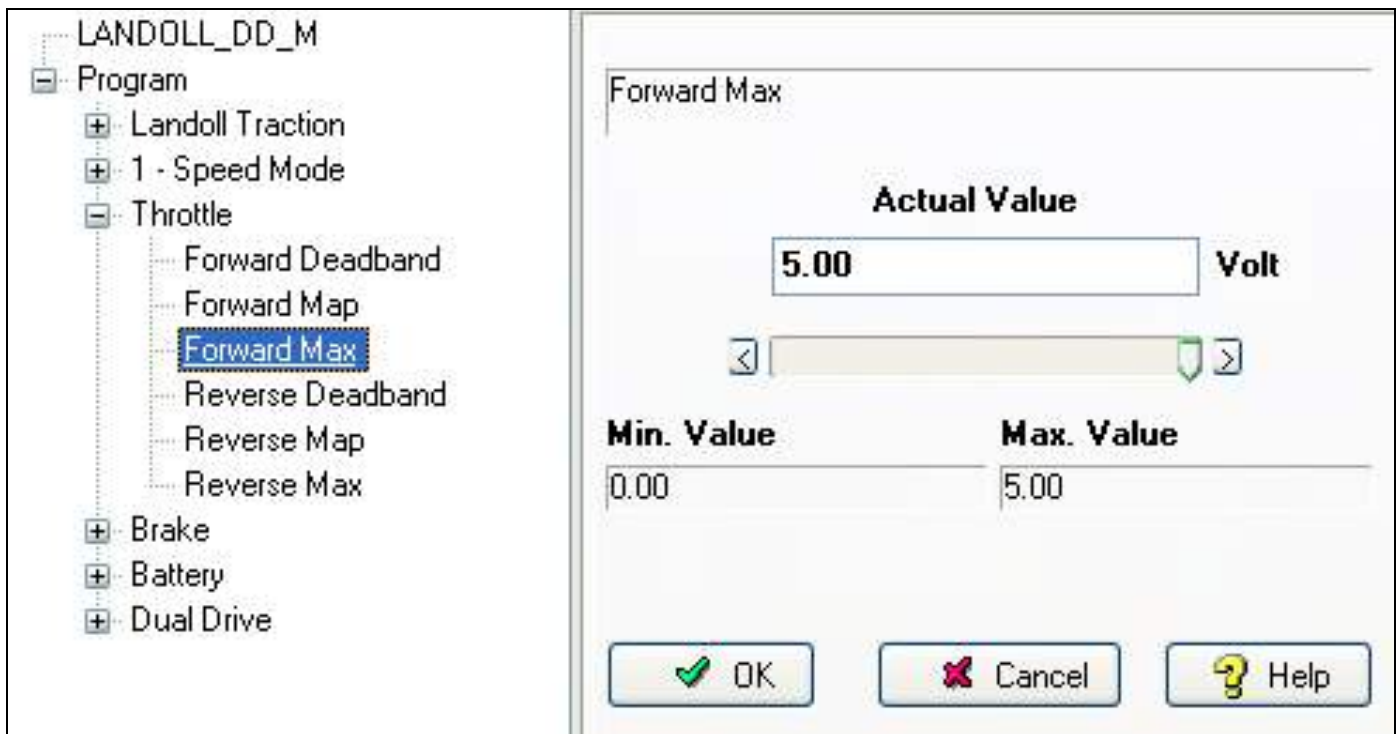

Figure 4-49: Forward Max

Forward Maximum: The value when the accelerator is fully depressed. Using the Monitor Menu, subtract .10 from the value shown for the Throttle Pot to get the appropriate value for this parameter. Should match Reverse Maximum.

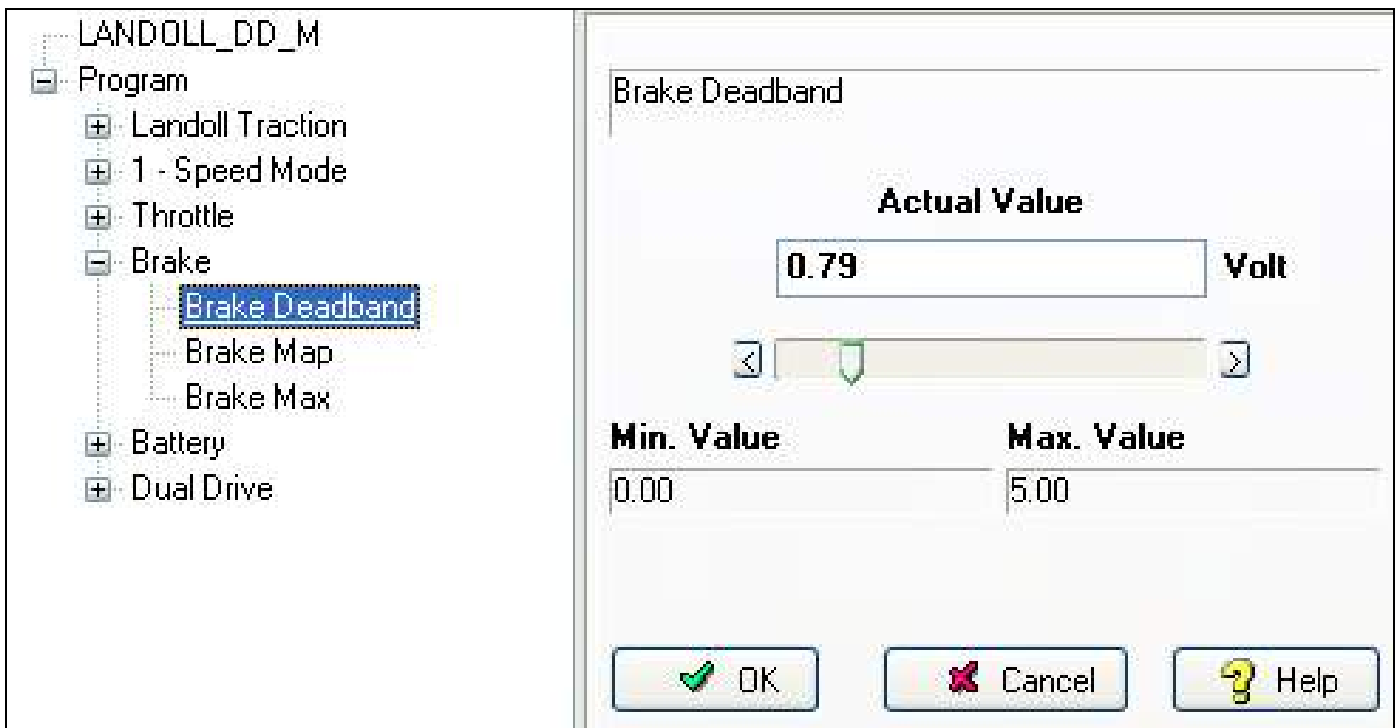

Figure 4-50: Brake Deadband

Brake Deadband: The value when the brake pedal is not being depressed. Using the Monitor Menu, add 2.0 to the value shown for the Brake Pot to get the appropriate value for this parameter. Should match Reverse Deadband.

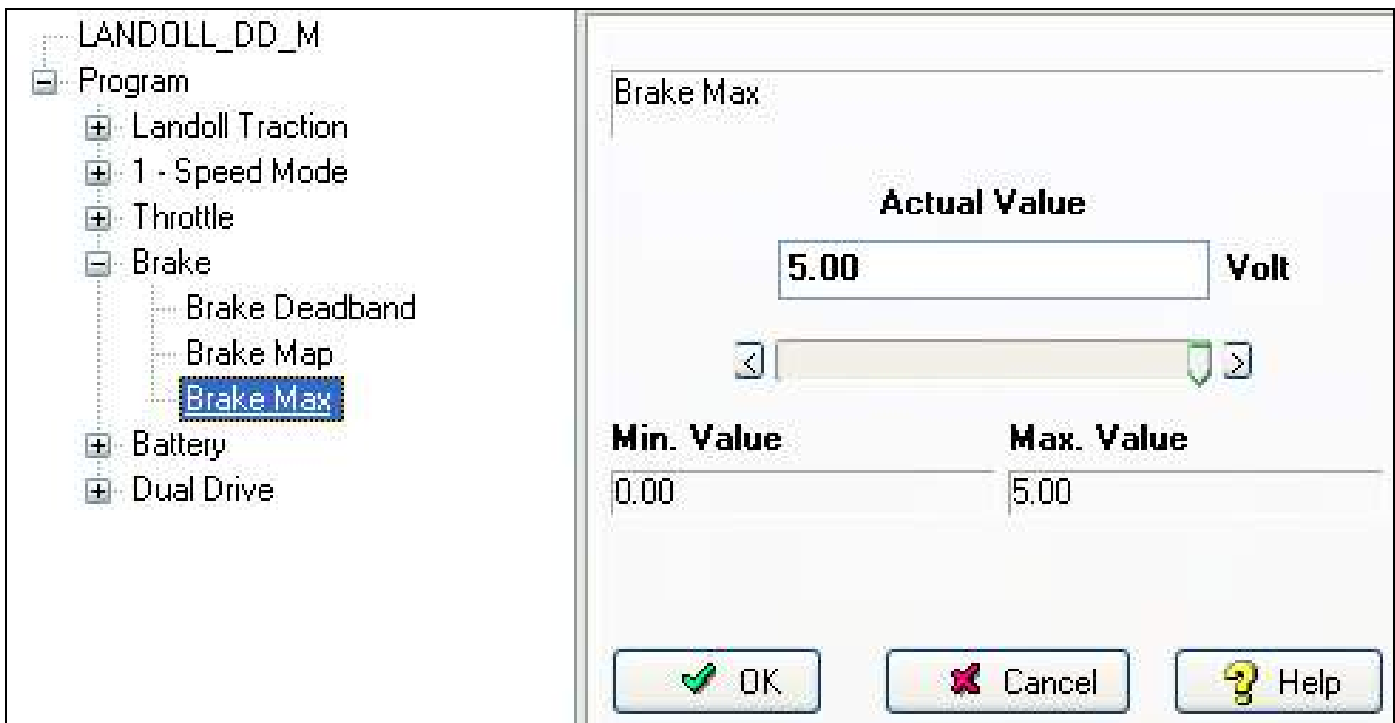

Figure 4-51: Brake Max

Brake Maximum: The value when the brake pedal is fully depressed. Using the Monitor Menu, subtract .10 from the value shown for the Brake Pot to get the appropriate value for this parameter. Should match Reverse Maximum.

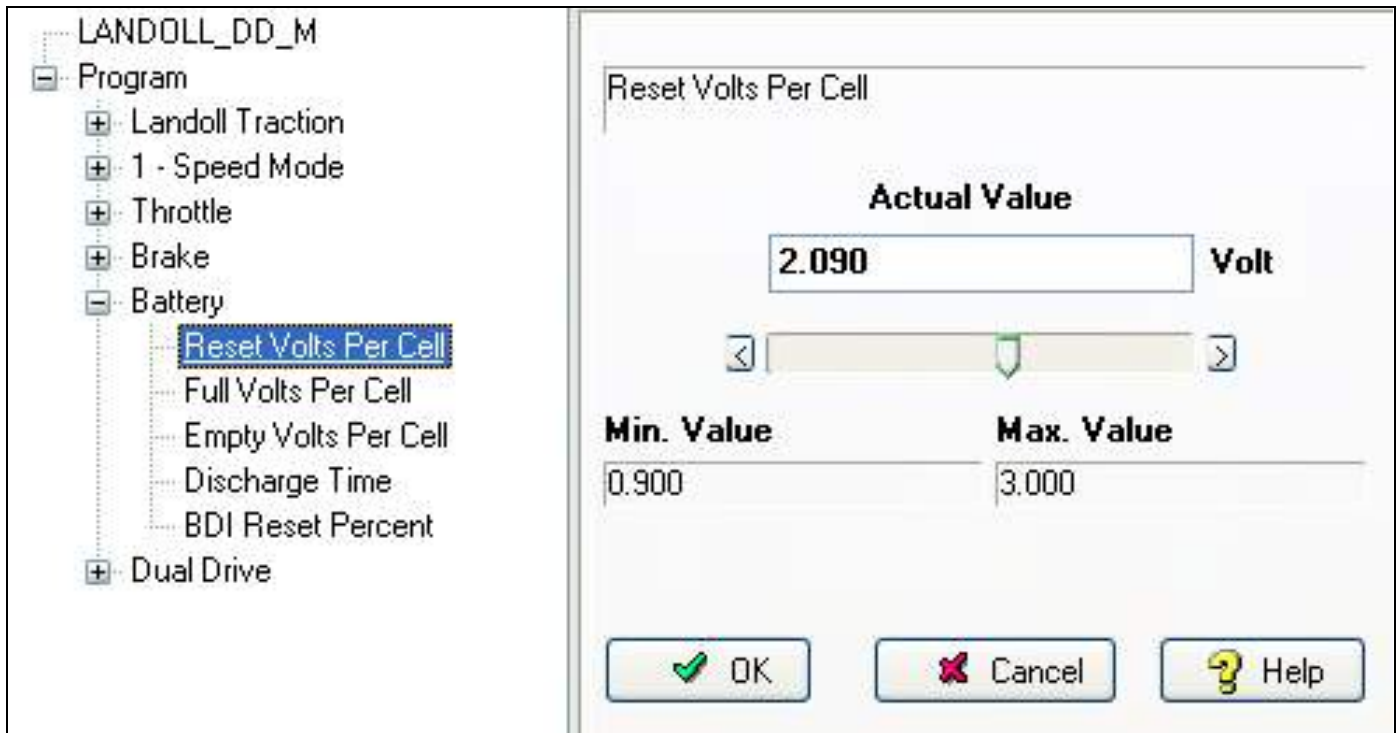

Figure 4-52: Reset Volts Per Cell

Reset Volts Per Cell: Landoll default setting. Changes are not recommended.



Figure 4-53: Full Volts Per Cell

Full Volts Per Cell: Landoll default setting. Changes are not recommended.

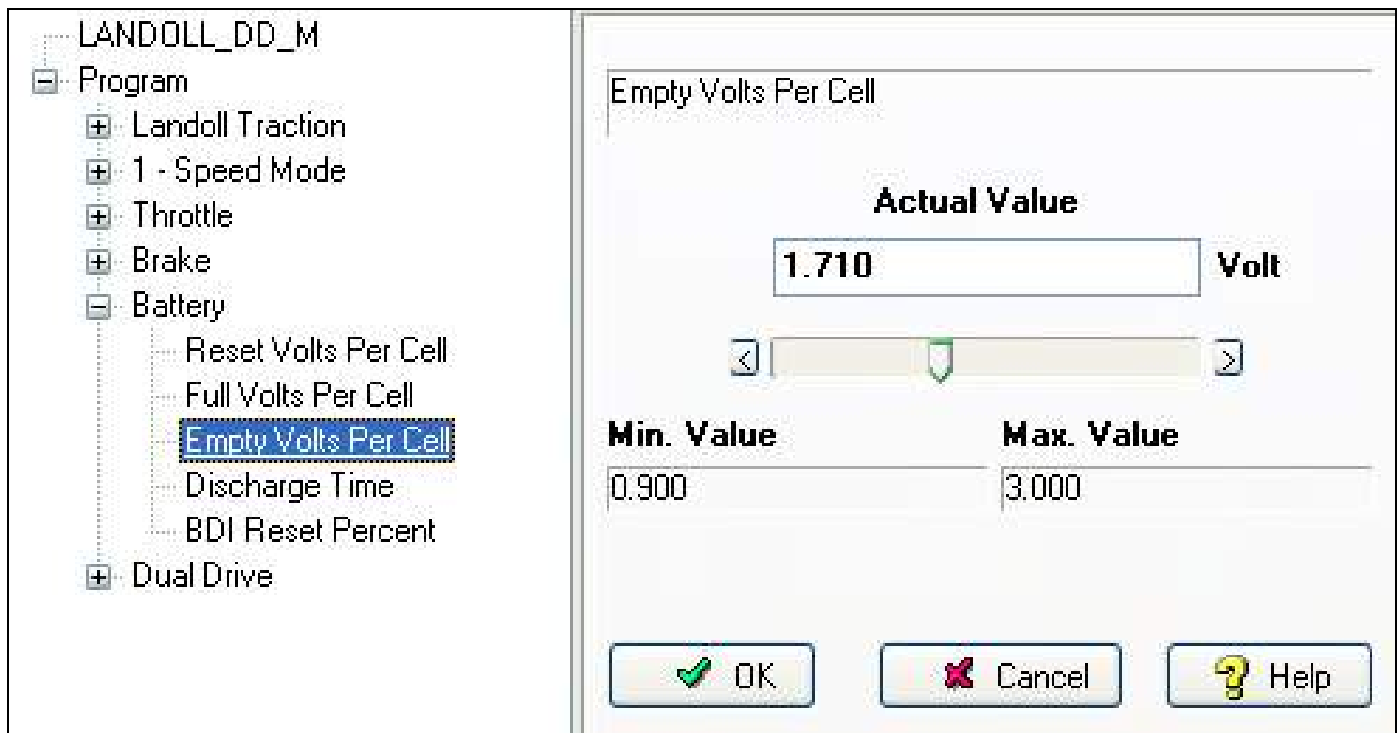

Figure 4-54: Empty Volts Per Cell

Empty Volts Per Cell: Landoll default setting. Changes are not recommended.

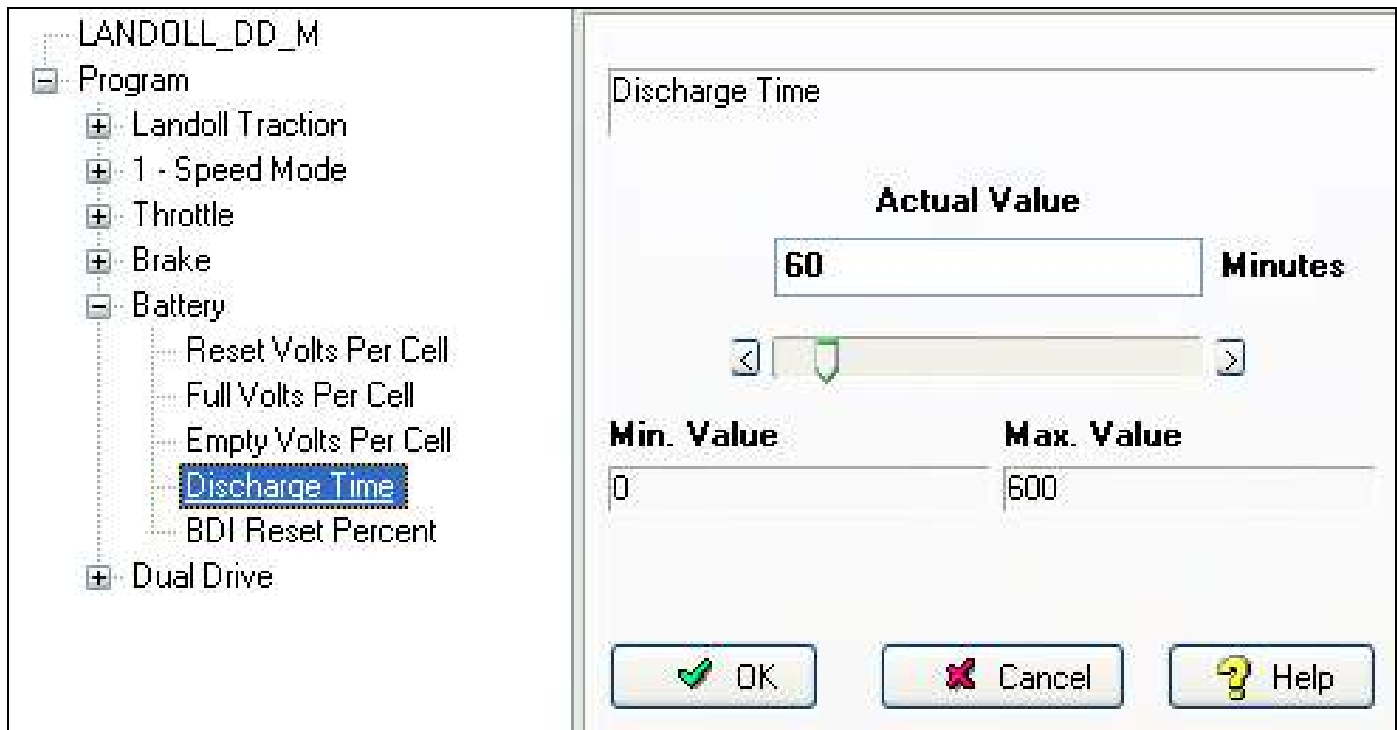

Figure 4-55: Discharge Time

Discharge Time: Sets the minimum time for the Battery Discharge Indicator to decrement from 100% to 0%.

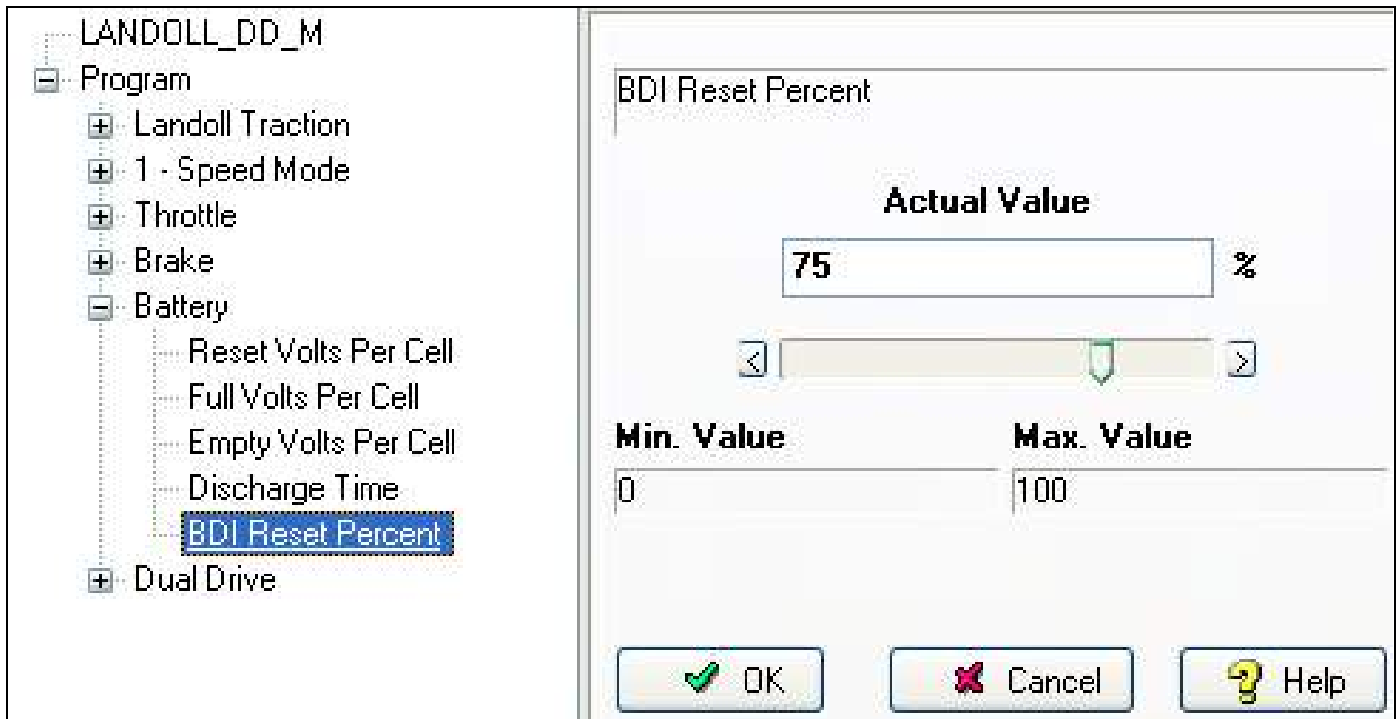

Figure 4-56: BDI Reset Percent

Battery Discharge Indicator Reset Percent: Defines a BDI percentage value above which the BDI% variable will not reset.

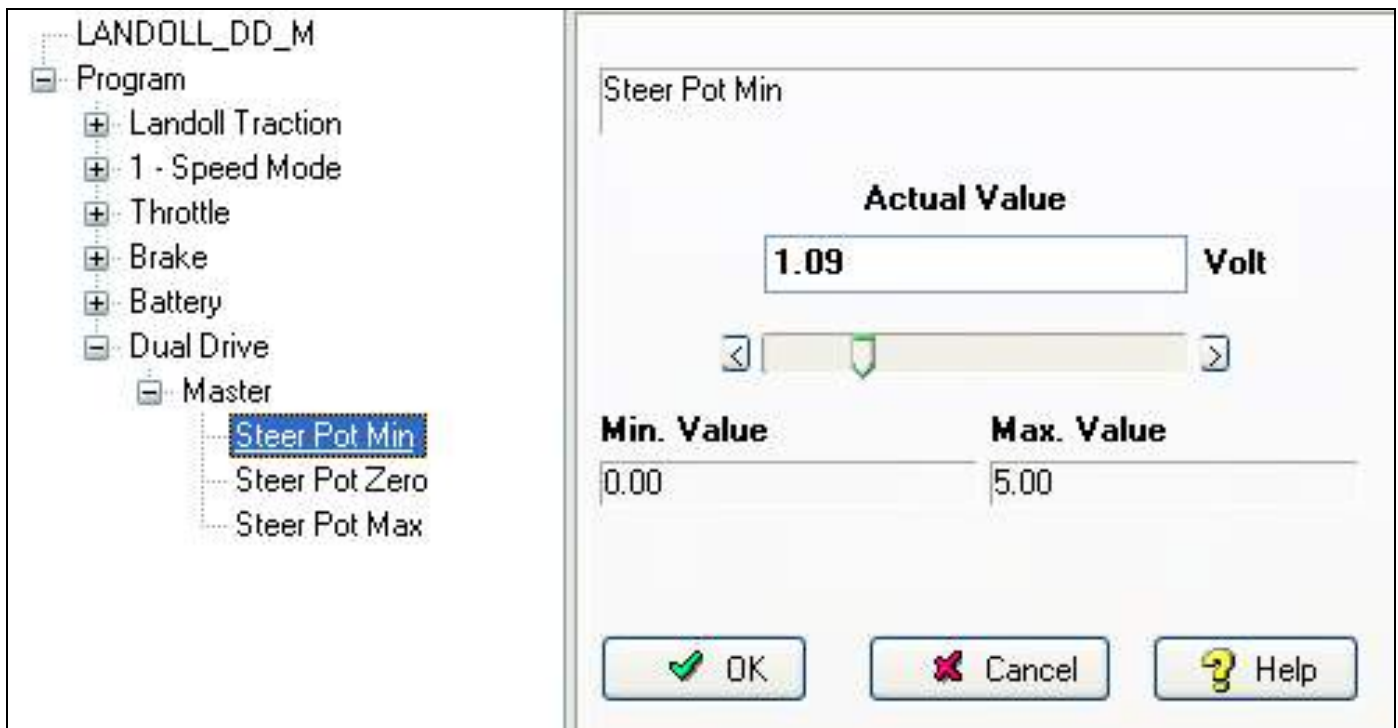

Figure 4-57: Steer Pot Min

Steer Potentiometer Minimum: Voltage on the steer pot when steering wheel turned completely counter-clockwise (left). Determined through the Monitor Menu under Steer Pot.

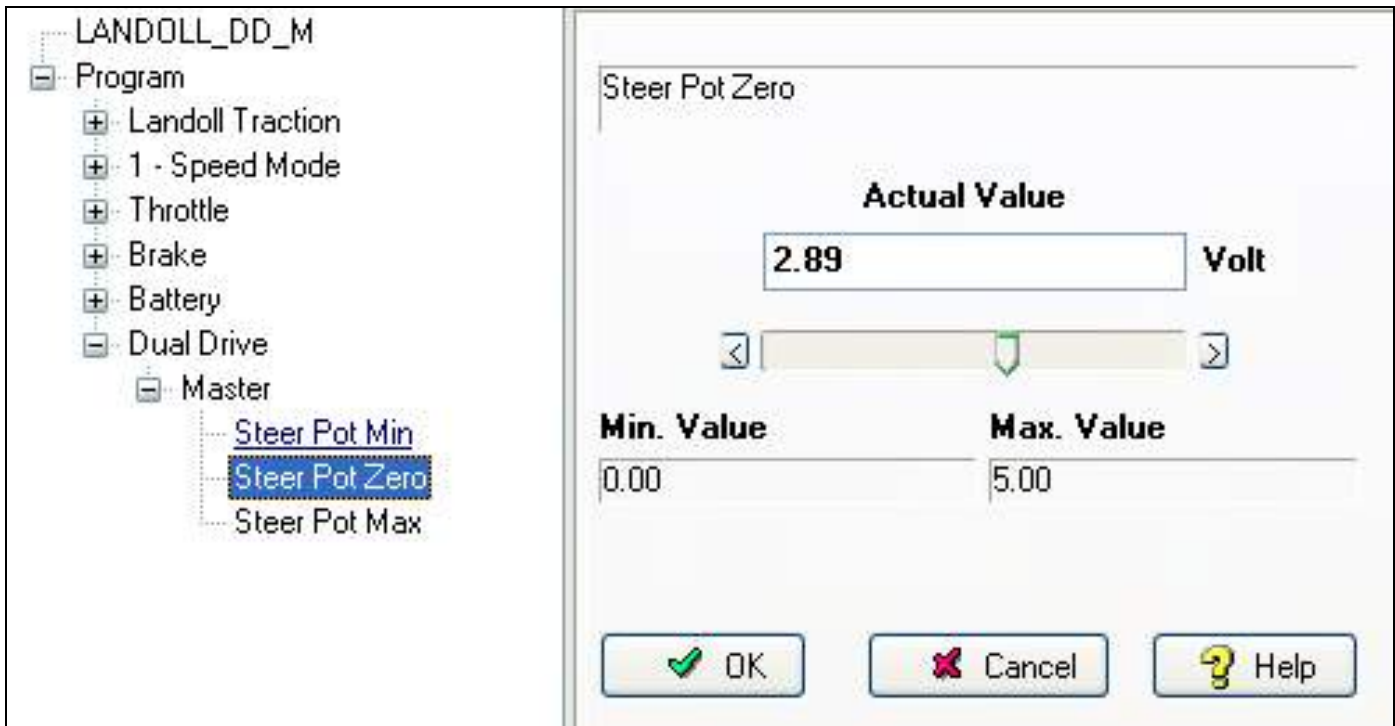

Figure 4-58: Steer Pot Zero

Steer Potentiometer Zero: Voltage on the steer pot when wheels are pointing straight ahead. Determined through the Monitor Menu under Steer Pot.

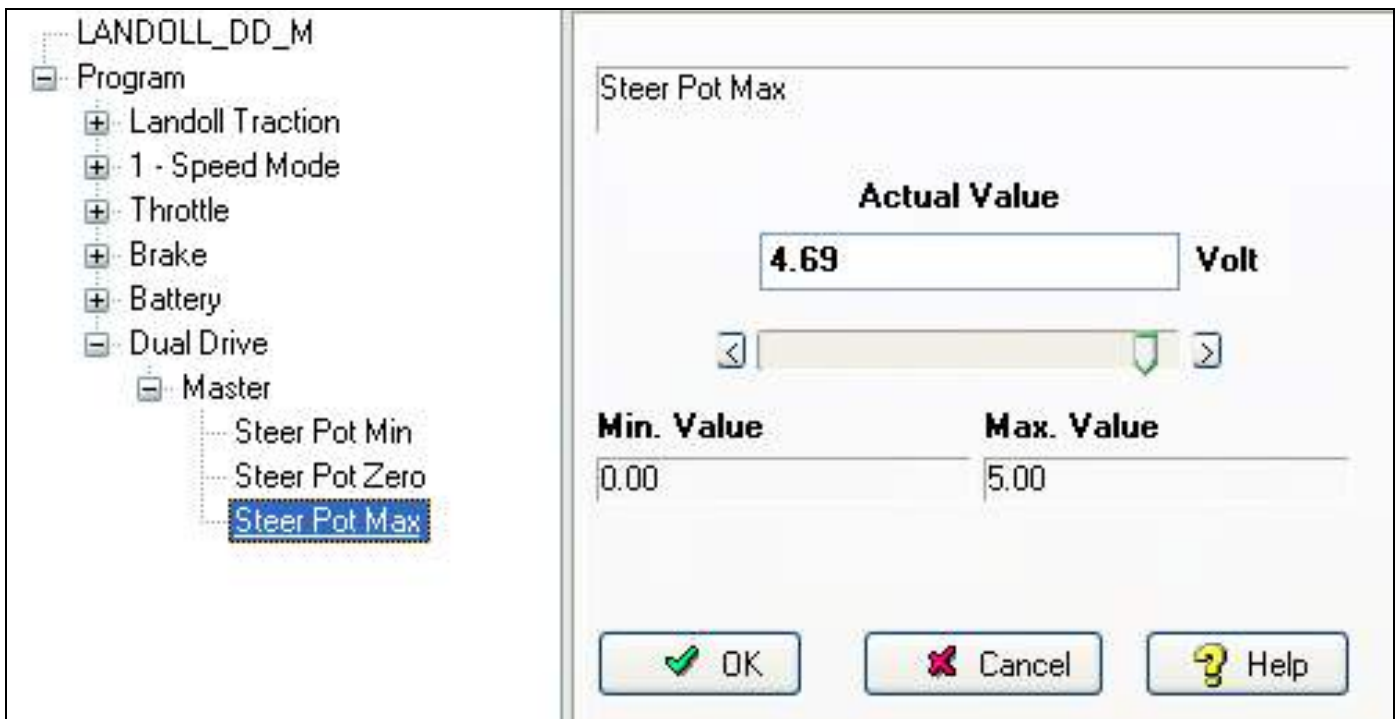

Figure 4-59: Steer Pot Max

Steer Potentiometer Maximum: Voltage on the steer pot when steering wheel turned completely clockwise. Determined through the Monitor Menu under Steer Pot.

Monitoring Default Parameters

Make sure that you have the controller selected (1) and click the Monitor Icon (2).



Figure 4-60: Monitor Menu

Monitor Value Name	Current Value	Unit
Lift Cutout Flag	Off	
Steer Pump Speed Flag	Off	
Pedal Brake Switch	Off	
Parking Brake Switch	On	
Seat Switch	On	
Battery Roll Out Switch	On	
Mode Switch	Off	
Throttle Pedal Switch	Off	
Forward Switch	Off	
Reverse Switch	Off	
Main Cont Driver PWM	78	%
Motor Temp Sensor Anal	1.21	Volt

Figure 4-61: Device Monitor

Landoll Parameter Details:

“Lift Cutout Flag” On when in Lift Lock-Out.

“Steer Pump Speed Flag” On when in forward or reverse AND driver is on the seat.

“Seat Switch” On when operator is in seat.

“Battery Roll Out Switch” (Optional) On when battery is correctly installed.

“Mode Switch” On when in Rabbit Mode, Off when in Turtle Mode.

“Throttle Pedal Switch” On when accelerator is depressed.

“Forward Switch” On when in Forward.

“Reverse Switch” On when in Reverse.

“Main Cont Driver PWM” 100% to pull in contactor and 80% to hold contactor.

“Motor Temp Sensor Analog” Linear Thermocouple reading.

Landoll	Throttle Command	0.0	%
Inputs	Mapped Throttle	0.0	%
Outputs	Throttle Pot	0.21	Volt
Battery	Brake Command	0.0	%
Motor	Mapped Brakes	0.0	%
Controller	Pot2 Raw	0.53	Volt
Vehicle	Mapped Hyd Throttle	0.0	%
CAN Status	Pump Throttle	0.00	%
Model Number	PD Throttle	0.00	%
Serial Number	Steer Pot	2.86	Volt
Mfg Date Code	Steer Angle (deg)	-2	
Hardware Version	Interlock	On	
OS Version	Emer Flw	Off	
Build Number	Analog 1	10.00	Volt
SM Version	Analog 2	1.21	Volt
Param Bk Version	Switch 1	On	
VCL App Version	Switch 2	Off	
	Switch 3	On	
	Switch 4	On	
	Switch 5	Off	
	Switch 6	Off	
	Switch 7	Off	
	Switch 8	Off	
	Driver 1 Input	Off	
	Driver 2 Input	Off	
	Driver 3 Input	Off	
	Driver 4 Input	Off	
	PD Input	Off	
	DigOut6 Input	Off	
	DigOut7 Input	Off	
	Switch 16	Off	

Figure 4-62: Factory Set Inputs

Inputs Parameter Details:

“**Throttle Command**” shows, in percentage, the amount of command being requested of the controller. (-100 - 100%)

“**Mapped Throttle**” shows, in percentage, the throttle being requested of the motors, factoring in speed setting, angle of steer pot, etc. (-100 - 100%)

“**Throttle Pot**” shows, in Volts, the value of the throttle’s potentiometer wiper. (0 - 5.5V)

“**Brake Command**” shows, in percentage, the amount of command being requested of the controller. (0 - 100%)

“**Mapped Brake**” shows, in percentage, the deceleration of the motors, factoring in speed setting, direction of travel, etc. (0 - 100%)

“**Pot2 Raw**” shows, in Volts, the value of the second potentiometer’s wiper. (0 - 5.5V)

“**Mapped Hyd Throttle**” shows, in percentage, speed being requested of the hydraulic throttle, factoring in the angle of the steer pot, mast operations, etc. (-100 - 100%)

“**Pump Throttle**” shows, in percentage, speed being requested of the hydraulic pump, factoring in the angle of steer pot, mast operations, etc. (0 - 100%)

“PD Throttle” shows, in percentage, the amount of the proportional driver current requested. (0 - 100%)

“Steer Pot” shows, in Volts, the value of the steering’s potentiometer wiper. (0 - 5.5V)

“Steer Angle (deg)” shows, in degrees, the steer angle calculated by the controller. (-90 - 90°)

“Interlock” shows if the interlock is on or off. (On - Off)

“Emer Rev” shows if the emergency reverse input is on or off. (On - Off)

“Analog 1” shows, in Volts, the value at analog input 1. (0 - 10.0V)

“Analog 2” shows, in Volts, the value at analog input 2. (0 - 10.0V)

“Switch (1-8)” shows if switches 1 through 8 are on or off. (On - Off)

“Driver (1-4) Input” shows if driver inputs (pins 6, 5, 4, and 3 respectively) are on or off. (On - Off)

“PD Input” shows if the proportional driver is on or off. *(On - Off)

“DigOut6 Input” shows if Digital Out input 6 (pin 19) is on or off. (On - Off)

“DigOut7 Input” shows if Digital Out input 7 (pin 20) is on or off. (On - Off)

“Switch 16” shows if switch 16 (pin 14) is on or off. (On - Off)

Monitor Value Name	Current Value	Unit
Analog Out	0.00	Volt
Digital Out 6	Off	
Digital Out 7	Off	
Driver 1 PWM	78	%
Driver 2 PWM	0	%
Driver 3 PWM	0	%
Driver 4 PWM	0	%
PD PWM	0	%
Pump PWM	0	%
PD Current	0.00	Ampere
Pump Current	0.0	Ampere
5 Volts	4.94	Volt
Ext Supply Current	44	mAmpere
Pot Low	0.21	Volt

Figure 4-63: Factory Set Outputs

Outputs Parameter Details:

“Analog Out” shows, in Volts, the value at the analog output. (0 - 10.0V)

“Digital Out 6” shows if the digital output from Digital Out 6 is on or off. (On - Off)

“Digital Out 7” shows if the digital output from Digital Out 7 is on or off. (On - Off)

“Driver 1 PWM” shows, in percentage, the driver 1 pulse-width modulation output at pin 6. (0 - 100%)

“Driver 2 PWM” shows, in percentage, the driver 2 pulse-width modulation output at pin 5. (0 - 100%)

“Driver 3 PWM” shows, in percentage, the driver 3 pulse-width modulation output at pin 4. (0 - 100%)

“Drive 4 PWM” shows, in percentage, the driver 4 pulse-width modulation output at pin 3. (0 - 100%)

“PD PWM” shows, in percentage, the proportional driver pulse-width modulation output at pin 2. (-100 - 100%)

“Pump PWM” shows, in percentage, the pulse-width modulation output of the DC pump motor. (0 - 100%)

“PD Current” shows, in Amps, the current of the proportional driver. (0 - 2.0)

CALIBRATION & PROGRAMMING

“**Pump Current**” shows, in Amps, the current in the DC pump motor. (0 - 2.0)

“**5 Volts**” shows, in Volts, the value of the +5V output at pin 26. (0 - 6.25)

“**Ext Supply Current**” shows, in milliAmps, the combined current of the external +12V and +5V supplies at pin 25 & 26 respectively. (5 - 200)

“**Pot Low**” shows, in Volts, the value of potentiometer low at pin 18. (0 - 6.25)

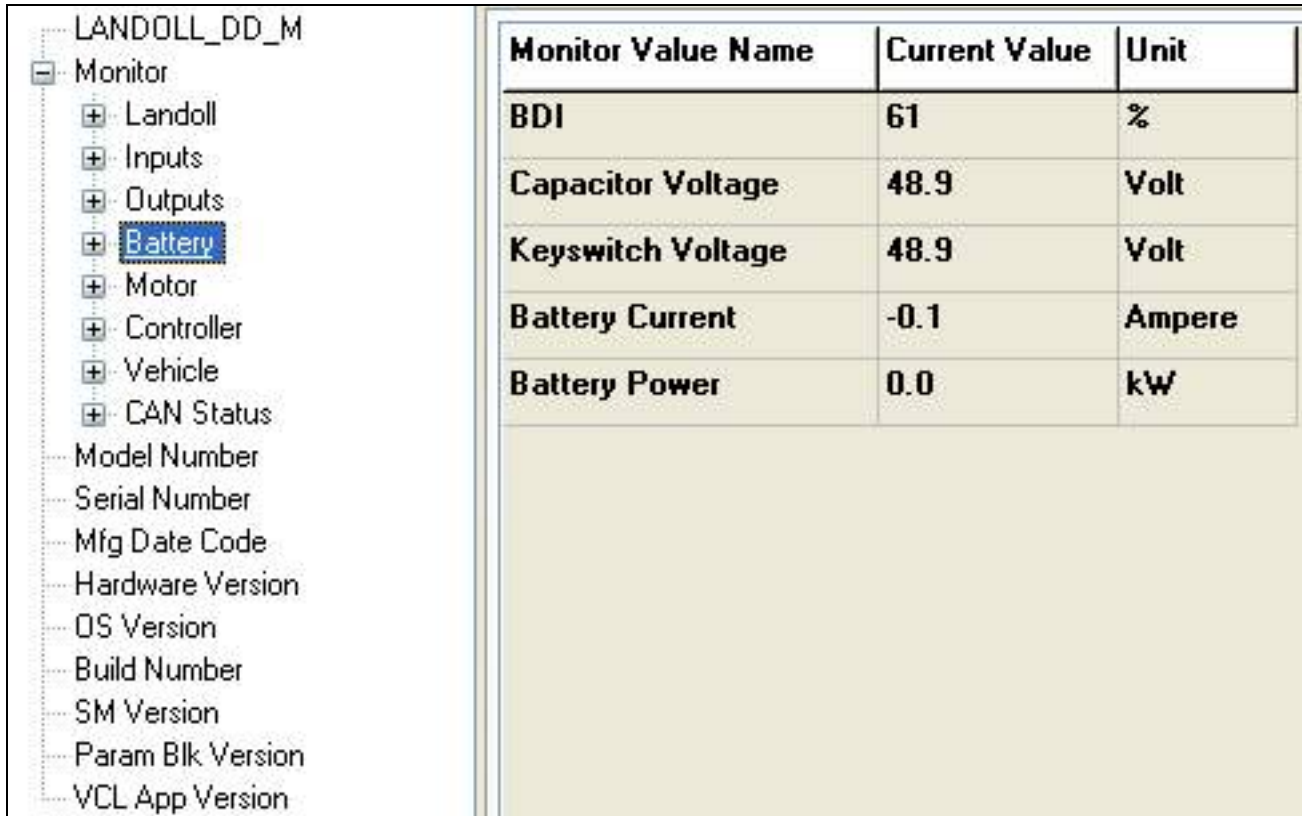

Monitor Value Name	Current Value	Unit
BDI	61	%
Capacitor Voltage	48.9	Volt
Keyswitch Voltage	48.9	Volt
Battery Current	-0.1	Ampere
Battery Power	0.0	kW

Figure 4-64: Battery Parameters

“**BDI**” shows, in percentage, the battery’s state of charge. (0 - 100%)

“**Capacitor Voltage**” shows, in Volts, the value of the controller’s internal capacitor bank at the B+ terminal. (0 - 105)

“**Keyswitch Voltage**” shows, in Volts, the value of the KSI at pin 1. (0 - 105)

“**Battery Current**” shows, in Amps, the current being pulled at the battery.

“**Battery Power**” shows, in kilowatts, power being used at the battery.

Monitor Value Name	Current Value	Unit
Motor RPM	0	rpm
Temperature	18	deg C
MotorSpeed A	0	rpm
MotorSpeed B	0	rpm

Figure 4-65: Motor Parameters

“**Motor RPM**” shows, in revolutions per minute, the speed of the motor. **(-12000 - 12000)**

“**Temperature**” shows, in degrees Celsius, temperature at the sensor readout. **(-100 - 300)**

“**MotorSpeed A**” shows, in revolutions per minute, the speed of the motor encoder phase A. Should equal MotorSpeed B. **(0 - 12000)**

“**MotorSpeed B**” shows, in revolutions per minute, the speed of the motor encoder phase B. Should equal MotorSpeed A. **(0 - 12000)**

Monitor Value Name	Current Value	Unit
Current (RMS)	2.9	Ampere
Modulation Depth	0.4	%
Frequency	0.0	Hz
Temperature	22	deg C
Main State	5	
Regen	On	
VCL Error Module	0	
VCL Error	0	
Motor Characterization E 0		

Figure 4-66: Controller Parameters

“**Current (RMS)**” shows, in Amps, the RMS current of the controller, all 3 phases taken into account. **(0 - 1000)**

“**Modulation Depth**” shows, in percentage, the value of the available voltage being used. **(0 - 100%)**

“**Frequency**” shows, in Hertz, the value of the controller’s electrical frequency. **(-300 - 300)**

“**Temperature**” shows, in degrees Celsius, the controller’s internal temperature. **(-100 - 300)**

“**Main State**” shows the state that the Main contactor is in. **(0 - 6.25)**

0 means open

1 means precharge

2 means weldcheck

3 means closing delay

4 means missing check

5 means closed (when Main Enable is on)

6 means delay

7 means arccheck

8 means opendelay

9 means fault

10 means closed (when Main Enable is off)

“**Regen**” shows if the regen braking is taking place. **(On - Off)**

“**VCL Error Module**” shows the value of the VCL Runtime Error. **(0 - 65536)**

“**VCL Error**” shows the value of the cause of the VCL Runtime Error. **(0 - 65536)**

“**Motor Characterization Error**” shows the value of the Motor Characterization Error. **(0 - 65536)**

0 means none

1 means encoder signal seen but unable to determine step size; must set up Encoder Step Size manually.

2 means the motor’s temperature sensor is at fault

3 means the motor temp hot cutback fault.

4 means the controller overtemp cutback fault.

5 means the controller undertemp cutback fault.

6 means the undervoltage cutback fault.

7 Severe overvoltage fault.

8 means encoder signal not seen, or one of the channels missing.

9 means motor parameters out of characterization range.

<p>LANDOLL_DD_M</p> <ul style="list-style-type: none"> Monitor <ul style="list-style-type: none"> Landoll Inputs Outputs Battery Motor Controller Vehicle CAN Status Model Number Serial Number Mfg Date Code Hardware Version OS Version Build Number SM Version Param Blk Version VCL App Version 	<table border="1"> <thead> <tr> <th>Monitor Value Name</th> <th>Current Value</th> <th>Unit</th> </tr> </thead> <tbody> <tr> <td>Vehicle Speed</td> <td>0.0</td> <td></td> </tr> <tr> <td>Vehicle Odometer</td> <td>10.4</td> <td></td> </tr> <tr> <td>Vehicle Acceleration</td> <td>0.000</td> <td>g</td> </tr> <tr> <td>Time to Speed 1</td> <td>0.00</td> <td>Seconds</td> </tr> <tr> <td>Time to Speed 2</td> <td>0.00</td> <td>Seconds</td> </tr> <tr> <td>Time Between Speeds</td> <td>0.00</td> <td>Seconds</td> </tr> <tr> <td>Time to Dist 1</td> <td>0.00</td> <td>Seconds</td> </tr> <tr> <td>Time to Dist 2</td> <td>0.00</td> <td>Seconds</td> </tr> <tr> <td>Time to Dist 3</td> <td>0.00</td> <td>Seconds</td> </tr> <tr> <td>Braking Distance Captur</td> <td>0.0</td> <td></td> </tr> <tr> <td>Distance Since Stop</td> <td>0.2</td> <td></td> </tr> <tr> <td>Distance Fine</td> <td>1.6</td> <td></td> </tr> </tbody> </table>	Monitor Value Name	Current Value	Unit	Vehicle Speed	0.0		Vehicle Odometer	10.4		Vehicle Acceleration	0.000	g	Time to Speed 1	0.00	Seconds	Time to Speed 2	0.00	Seconds	Time Between Speeds	0.00	Seconds	Time to Dist 1	0.00	Seconds	Time to Dist 2	0.00	Seconds	Time to Dist 3	0.00	Seconds	Braking Distance Captur	0.0		Distance Since Stop	0.2		Distance Fine	1.6	
Monitor Value Name	Current Value	Unit																																						
Vehicle Speed	0.0																																							
Vehicle Odometer	10.4																																							
Vehicle Acceleration	0.000	g																																						
Time to Speed 1	0.00	Seconds																																						
Time to Speed 2	0.00	Seconds																																						
Time Between Speeds	0.00	Seconds																																						
Time to Dist 1	0.00	Seconds																																						
Time to Dist 2	0.00	Seconds																																						
Time to Dist 3	0.00	Seconds																																						
Braking Distance Captur	0.0																																							
Distance Since Stop	0.2																																							
Distance Fine	1.6																																							

Figure 4-67: Vehicle Parameters

“**Vehicle Speed**” shows, in miles per hour, the current speed of the vehicle. [\(-327.7 - 327.7\)](#)

“**Vehicle Odometer**” shows, in miles, the distance the vehicle has traveled. [\(0 - 42949672.9\)](#)

“**Vehicle Acceleration**” shows, in gravitational units, the acceleration of the vehicle [\(0 - 6.25\)](#)

“**Time to Speed 1**” shows, in seconds, the length of time taken for the vehicle to go from zero rpm to the programmed Capture Speed 1 during its most recent acceleration. [\(0 - 128\)](#)

“**Time to Speed 2**” shows, in seconds, the length of time taken for the vehicle to go from zero rpm to the programmed Capture Speed 2 during its most recent acceleration. [\(0 - 128\)](#)

“**Time Between Speeds**” shows, in seconds, the length of time for the vehicle to go from programmed Capture Speed 1 to programmed Capture Speed 2 during its most recent acceleration. [\(0 - 6.25\)](#)

“**Time to Dist 1**” shows, in seconds, the length of time taken for the vehicle to travel from zero rpm to the Programmed Capture Distance 1 during its most recent trip. [\(0 - 128\)](#)

“**Time to Dist 2**” shows, in seconds, the length of time taken for the vehicle to travel from zero rpm to the programmed Capture Distance 2 during its most recent trip. [\(0 - 128\)](#)

“**Time to Dist 3**” shows, in seconds, the length of time taken for the vehicle to travel from zero rpm to the programmed Capture Distance 3 during its most recent trip. [\(0 - 128\)](#)

“**Braking Distance Captured**” shows, in feet, the distance traveled by the vehicle starting with the vehicle braking (initiated by throttle reversal, VCL_Brake or interlock braking) and ending when motor rpm reaches zero. [\(0 - 1000000.0\)](#)

“**Distance Since Stop**” shows, in feet, the distance traveled by the vehicle starting from a stop. In effect, the vehicle is used as a tape measure. The value will reset when the motor rpm reaches zero. [\(0 - 6.25\)](#)

“**Distance Fine**” shows, in inches, the net distance in both the forward and reverse directions. Eg. 20 inches forward and 20 inches backward will result in zero. [\(-214748364.8 - 214748364.7\)](#)

Monitor Value Name	Current Value	Unit
CAN NMT State	127	

Figure 4-68: CAN Status Parameters

“CAN NMT State” shows the current Controller CAN NMT State.

- 0 means initialization
- 4 means stopped
- 5 means operational
- 127 means pre-operational.

After successfully re-flashing a controller, make sure to clear the fault history of all comments.

Landoll_DD_S Parameters

Explanation of controller parameters are shown below in the following tables. Slave parameters are not adjustable.

DESCRIPTION	Unit	Value	Min	Max	Text Description
Landoll Traction					
HPD Sequencing Delay	Sec	2	0	5	Sets amount of time an operator can be off seat before SRO enables.
Steer Cont PWM	%	100	0	100	Sets the voltage to the steer contactor.
Steering Off Delay	Sec	10	0	30	Time that the pump continues to run after operator leaves seat.
Lift Lockout Level	%	0	0	99	Determines battery percentage before LOS engages.
Multimode Functions					
Rabbit Fwd Max Speed	%	100	0	100	Sets maximum speed of vehicle in rabbit mode.
Turtle Fwd Max Speed	%	15	0	100	Sets maximum speed of vehicle in turtle mode.
Rabbit Rev Max Speed	%	90	0	100	Sets maximum speed of vehicle in rabbit mode.
Turtle Rev Max Speed	%	15	0	100	Sets maximum speed of vehicle in turtle mode.
HourMeter					
Set Total HM		0	0	1	Set to 1 to write 10s of hours and remaining hours in minutes to controllers.
10s of Hours		0	0	20000	Sets 10s of hours. (I.E. 90=900 hours)
Remaining HRs in min.		0	0	600	Sets remaining hours in minutes. (I.E. 60=1hour)
Maintenance Due					
Next Service Due					When hour meter = next service due, maintenance due will be displayed on dash.
Speed Mode					
Response					
Full Accel Rate HS	Sec	0.1	3.0	30.0	Sets the rate at which the speed command increases when full throttle is applied at high vehicle speeds. Larger values represent slower response.
Full Accel Rate LS	Sec	0.1	3.0	30.0	Sets the rate at which the speed command increases when full throttle is applied at low vehicle speeds. Larger values represent slower response.
Low Accel Rate	Sec	0.1	10.0	30.0	Sets the rate at which the speed command increases when a small amount of throttle is applied. Typically adjusted to affect low speed control.
Neutral Decel LS	Sec	0.1	7.0	30.0	Sets the rate slows down the vehicle when the throttle is released to neutral at high vehicle speeds. Larger values represent slower response.
Neutral Decel Rate HS	Sec	0.1	2.5	30.0	Sets the rate that slows down the vehicle when the throttle is released to neutral at slow vehicle speeds. Larger values represent slower response.
Full Brake Rate HS	Sec	0.1	1.0	30.0	Sets the rate at which the vehicle slows down from high speeds when full brake is applied or when full throttle is applied in the opposite direction. Larger values represent slower response.
Full Brake Rate LS	Sec	0.1	2.5	30.0	Sets the rate at which the vehicle slows down from low speeds when full brake is applied or when full throttle is applied in the opposite direction. Larger values represent slower response.
Low break Rate	Sec	0.1	6.0	30.0	Sets the rate at which the vehicle slows down at all speeds when a small amount of brake is applied or a small amount of throttle is applied in the opposite direction. Larger values gives a slower response
Fine Tuning					

CALIBRATION & PROGRAMMING

DESCRIPTION	Unit	Value	Min	Max	Text Description
Partial Decel Rate	Sec	0.1	30.0	30.0	Sets the rate that is used to slow down the vehicle when the throttle is reduced without being released to neutral. Larger values represent slower response.
HS (High Speed)	Sec	0	70	100	Sets the percentage of the Typical Max Speed above which parameters will be used.
LS (Low Speed)	Sec	0	30	100	Sets the percentage of the Typical Max Speed below which the "LS" parameters will be used.
Reversal Soften	Sec	0	20	100	Larger values create a softer reversal from regen braking to drive when near zero speed. This helps soften the transition when the regen and drive current limits are set to different values.
Max Speed Accel	Sec	.1	1.0	30.0	In some applications, the Max Speed value is changed frequently through VCL or over the CAN bus. The Max Speed Accel parameter controls the rate at which the maximum speed setpoint is allowed to change when the value of Max Speed is raised. The rate set by this parameter is the time to ramp from 0 rpm to Typical Max Speed rpm. For example, suppose Max Speed is raised from 1000 rpm to 4000 rpm. If Typical Max Speed is 5000 rpm, and the rate is 10.0 seconds, it will take $10.0 * (4000-1000) / 5000 = 6.0$ seconds to ramp from 1000 rpm to 4000 rpm.
Max Speed Decel	Sec	0.1	10	30	This parameter works like the Max Speed Accel parameter, except that it controls the rate at which the maximum speed setpoint is allowed to change when the value of Max Speed is lowered. For example, suppose you change Max Speed from 4500 rpm to 2500 rpm. If Typical Max Speed is 5000 rpm, and the rate is 5.0 seconds, it will take $5.0 (4500-2500) / 5000 = 2.0$ seconds to ramp from 4500 rpm to 2500 rpm.
Throttle					
Forward Deadband	Volt	Auto set during calibration.	0	5	Defines the wiper voltage at the throttle deadband threshold. Increasing the throttle deadband setting will increase the neutral range. This parameter is especially useful with throttle assemblies that do not reliably return to a well-defined neutral point, because it allows the deadband to be defined wide enough to ensure that the controller goes into neutral when the throttle mechanism is released.
Forward Max	Volt	Auto set during calibration.	0	5	Defines the wiper voltage required to produce 100% controller output. Decreasing the throttle max setting reduces the wiper voltage and therefore the full stroke necessary to produce full controller output. This parameter allows reduced-range throttle assemblies to be accommodated.
Reverse Deadband	Volt	10	2	125	The four Throttle Reverse parameters are the same as their Throttle Forward counterparts, and apply when the throttle direction is reversed.
Reverse Max	Volt	3	0	5	Same as above.
Brake					
Brake Deadband	ms	48	40	2000	The four Brake throttle adjustment parameters are the same as their Drive throttle counterparts
Brake Max	ms	200	0	800	Same as above.
Battery					

DESCRIPTION	Unit	Value	Min	Max	Text Description
Reset Volts Per Cell	Volt	2.09	0.9	3	The value of this parameter is a percentage of the Nominal Voltage setting. The User Undervoltage parameter can be used to adjust the undervoltage threshold, which is the voltage at which the controller will cut back drive current to prevent damage to the electrical system. Typically this parameter is changed only when the controller is being used in an application at the high end of the controller's range: such as a 24–36V controller being used in a system with a 36V battery pack. In this case, the undervoltage threshold can be lowered by setting the User Undervoltage to a lower value. The undervoltage threshold can never be lowered below the controller's power base minimum voltage rating.
Full Volts Per Cell	Volt	2.04	0.9	3	The reset voltage level is checked only once, when KSI is first turned on. Note that the BDI Reset Percent parameter also influences the algorithm that determines whether BDI Percentage is reset to 100%. Reset Volts Per Cell should always be set higher than Full Volts Per Cell. $\text{Reset Voltage Level} = \text{Reset Volts Per Cell} \times \text{number of cells in the battery pack}$
Empty Volts Per Cell	Volt	1.71	0.9	3	The full voltage level sets the Keyswitch Voltage that is considered to be 100% state-of-charge; when a loaded battery drops below this voltage, it begins to lose charge. Keyswitch Voltage is viewable in the 1311 menu Monitor » Battery. $\text{Full Voltage Level} = \text{Full Volts Per Cell} \times \text{number of cells in the battery pack}$.
Discharge Time	Min	60	0	600	Sets the minimum time for the BDI algorithm to count down the BDI Percentage from 100% to 0%. The BDI algorithm integrates the time the filtered keyswitch voltage is below the state of charge voltage level. When that cumulative time exceeds the $\text{Discharge Time} / 100$, the BDI Percentage is decremented by one percentage point and a new state of charge voltage level is calculated. $\text{State of Charge Level} = ((\text{Full Voltage Level} - \text{Empty Voltage Level}) \times \text{BDI Percentage} / 100) + \text{Empty Voltage Level}$.

CALIBRATION & PROGRAMMING

DESCRIPTION	Unit	Value	Min	Max	Text Description
BDI Reset Percent	%	75	0	100	When a battery has a high BDI percentage, its float voltage at KSI On can sometimes cause false resets. The BDI Reset Percent parameter addresses this problem by allowing the user to define a BDI Percentage value above which the BDI Percentage variable will not reset. When KSI is first powered on, the BDI Percentage variable will reset to 100% only if ((Keyswitch Voltage > Reset Voltage Level) and (BDI Percentage < BDI Reset Percent)).
Dual Drive					
Master					
Steer Pot Min	Volt	1.12	0	5	Set Steer Pot Min to the voltage on the steering pot when steering as far as possible clockwise. Determine the value by reading the voltage on the pot when steering CW to the maximum position.
Steer Pot Zero	Volt				Set Steer Pot Zero to the voltage on the steering pot when steering straight ahead. Determine the value by reading the voltage on the pot when steering straight.
Steer Pot Max	Volt	4.77	0	5	Set Steer Pot Max to the voltage on the steering pot when steering as far as possible counterclockwise. Determine the value by reading the voltage on the pot when steering CCW to the maximum position.

Landoll_P_B55 Parameters

DESCRIPTION	Unit	Value	Min	Max	Text Description
Landoll Pump					
Pump Speeds					
Max Total Speed	rpm	2600	1000	5000	Max Pump motor RPM
Sideshift Speed	rpm	900	0	5000	Sideshift maximum motor RPM
Tilt Speed	rpm	900	0	5000	Tilt maximum motor RPM
Lift Speed	rpm	See p. 5-38.	0	5000	Lift maximum motor RPM
Steer Speed	rpm	850	0	5000	Steer maximum motor RPM
Seat Hydraulics Enable		0	0	1	When off, hydraulics can be operated without operator on seat. On: Can be operated regardless of seat switch.
Throttle					
Lift Deadband	Volt	2.72	0	5	Defines the wiper voltage at the throttle deadband threshold. Increasing the throttle deadband setting will increase the neutral range. This parameter is especially useful with throttle assemblies that do not reliably return to a well-defined neutral point, because it allows the deadband to be defined wide enough to ensure that the controller goes into neutral when the throttle mechanism is released.
Lift Max	Volt	3.8	0	5	Defines the wiper voltage required to produce 100% controller output. Decreasing the throttle max setting reduces the wiper voltage and therefore the full stroke necessary to produce full controller output. This parameter allows reduced-range throttle assemblies to be accommodated.

Curtis Controller Troubleshooting

IMPORTANT

The following troubleshooting chart provides information on the Curtis controller faults:

- • Fault code
- • Fault name displayed on the dash display.
- • The effect of the fault
- • Possible causes of the fault
- • Fault *set* conditions
- • Fault *clear* conditions

NOTE

Whenever a fault is encountered and no wiring or vehicle fault can be found, shut off KSI (Key Switch Interrupt) and turn it back on to see if the fault clears. If it does not, shut off Keyswitch Interrupt (KSI) and remove the 35-pin connector. Check the connector for corrosion, damage or unseated terminals. If necessary, clean the pins and re-insert them.



Figure 4-69: LED Status

TYPES OF LED DISPLAY

DISPLAY	STATUS
Neither LED illuminated	Controller is not powered on; or vehicle has dead battery; or severe damage.
Yellow LED flashing	Controller is operating normally.
Yellow and red LED's both on solid	Controller is in Flash program mode.
Red LED on solid	Watchdog failure or no software loaded. Cycle KSI to restart, and if necessary load software.
Red LED and yellow LED flashing alternately	Controller has detected a fault. 2-digit code flashed by yellow LED identifies the specific fault; one or two flashes by red LED indicate whether first or second code digit will follow.

See Figure 4-69. For illustration, see photo or refer to Controller panel shown on page 3-28 for the left, pump and right controllers, the interconnect cables and the LED lights.

Program Troubleshooting Chart

C O D E	PROGRAMMER LCD DISPLAY	T	P	POSSIBLE CAUSE	SET/CLEAR CONDITIONS
12	Controller Overcurrent <i>ShutdownMotor;</i> <i>ShutdownMainContactor;</i> <i>ShutdownEMBrake;</i> <i>ShutdownThrottle;</i> <i>FullBrake;</i> <i>ShutdownPump.</i>	X	X	1. External short of phase U,V, or W motor connections. 2. Motor parameters are mis-tuned. 3. Controller defective.	<i>Set:</i> Phase current exceeded the current measurement limit. <i>Clear:</i> Cycle KSI.
13	Current Sensor Fault <i>ShutdownMotor;</i> <i>ShutdownMainContactor;</i> <i>ShutdownEMBrake;</i> <i>ShutdownThrottle;</i> <i>FullBrake;</i> <i>ShutdownPump.</i>	X	X	1. Leakage to vehicle frame from phase U, V, or W (short in motor stator). 2. Controller defective.	<i>Set:</i> Controller current sensors have invalid offset reading. <i>Clear:</i> Cycle KSI.
14	Precharge Failed <i>ShutdownMotor;</i> <i>ShutdownMainContactor;</i> <i>ShutdownEMBrake;</i> <i>ShutdownThrottle;</i> <i>Full Brake;</i> <i>ShutdownPump.</i>	X	X	1. See Monitor menu » Battery: Capacitor Voltage. 2. External load on capacitor bank (B+ connection terminal) that prevents the capacitor bank from charging.	<i>Set:</i> Precharge failed to charge the capacitor bank to the KSI voltage. <i>Clear:</i> Cycle Interlock input or use VCL function Precharge().
15	Controller Severe Undertemp <i>ShutdownMotor;</i> <i>ShutdownMainContactor;</i> <i>ShutdownEMBrake;</i> <i>ShutdownThrottle;</i> <i>FullBrake;</i> <i>ShutdownPump.</i>	X	X	1. See Monitor menu » Controller: Temperature. 2. Controller is operating in an extreme environment.	<i>Set:</i> Heatsink temperature below -40°C. <i>Clear:</i> Bring heatsink temperature above -40°C, and cycle interlock or KSI.
16	Controller Severe Overtemp <i>ShutdownMotor;</i> <i>ShutdownMainContactor;</i> <i>ShutdownEMBrake;</i> <i>ShutdownThrottle;</i> <i>FullBrake;</i> <i>ShutdownPump.</i>	X	X	1. See Monitor menu » Controller: Temperature. 2. Controller is operating in an extreme environment. 3. Excessive load on vehicle. 4. Improper mounting of controller.	<i>Set:</i> Heatsink temperature above +95°C. <i>Clear:</i> Bring heatsink temperature below +95°C, and cycle interlock or KSI.
17	Severe Undervoltage Reduced drive torque.	X	X	1. Battery Menu parameters are misadjusted. 2. Non-controller system drain on battery. 3. Battery resistance too high. 4. Battery disconnected while driving. 5. See Monitor menu » Battery: Capacitor Voltage. 6. Blown B+ fuse or main contactor did not close.	<i>Set:</i> Capacitor bank voltage dropped below the Severe Undervoltage limit (see page 55) with FET bridge enabled. <i>Clear:</i> Bring capacitor voltage above Severe Undervoltage limit.
18	Severe Overvoltage <i>ShutdownMotor;</i> <i>ShutdownMainContactor;</i> <i>ShutdownEMBrake;</i> <i>ShutdownThrottle;</i> <i>FullBrake;</i> <i>ShutdownPump.</i>	X	X	1. See Monitor menu » Battery: Capacitor Voltage. 2. Battery menu parameters are misadjusted. 3. Battery resistance too high for given regen current. 4. Battery disconnected while regen braking.	<i>Set:</i> Capacitor bank voltage exceeded the Severe Overvoltage limit (see page 55) with FET bridge enabled. <i>Clear:</i> Bring capacitor voltage below Severe Overvoltage limit, and then cycle KSI.

C O D E	PROGRAMMER LCD DISPLAY	T	P	POSSIBLE CAUSE	SET/CLEAR CONDITIONS
22	Controller Overtemp Cutback <i>Reduced drive and brake torque.</i>	X	X	1. See Monitor menu » Controller: Temperature. 2. Controller is performance-limited at this temperature. 3. Controller is operating in an extreme setting. 4. Excessive load on vehicle. 5. Improper mounting of controller	<i>Set:</i> Heat sink temperature exceeded 85°C. <i>Clear:</i> Bring heat sink temperature below 85°C.
23	Undervoltage Cutback <i>Reduced drive torque.</i>	X	X	1. Normal operation. Fault shows that the batteries need recharging. Controller is performance limited at this voltage. 2. Battery parameters are misadjusted. 3. Non-controller system drain on battery. 4. Battery resistance too high. 5. Battery disconnected while driving. 6. See Monitor menu » Battery: Capacitor Voltage. 7. Blown B+ fuse or main contactor did not close.	<i>Set:</i> Capacitor bank voltage dropped below the Undervoltage limit (see page 55) with the FET bridge enabled. <i>Clear:</i> Bring capacitor voltage above the undervoltage limit.
24	Overvoltage Cutback <i>Reduced brake torque.</i>	X	X	1. Normal operation. Fault shows that regen braking currents elevated the battery voltage during regen braking. Controller is performance limited at this voltage. 2. Battery parameters are misadjusted. 3. Battery resistance too high for given regen current. 4. Battery disconnected while regen braking. 5. See Monitor menu » Battery: Capacitor Voltage.	<i>Set:</i> Capacitor bank voltage exceeded the Overvoltage limit (see page 55) with the FET bridge enabled. <i>Clear:</i> Bring capacitor voltage below the Overvoltage limit.
25	+5V Supply Failure <i>None, unless a fault action is programmed in VCL.</i>	X	X	1. External load impedance on the +5V supply (pin 26) is too low. 2. See Monitor menu » outputs: 5 Volts and Ext Supply Current.	<i>Set:</i> +5V supply (pin 26) outside the +5V±10% range. <i>Clear:</i> Bring voltage within range.
28	Motor Temp Hot Cutback <i>Reduced drive torque.</i>	X	X	1. Motor temperature is at or above the programmed Temperature Hot setting, and the requested current is being cut back. 2. Motor Temp Control Menu parameters are mis-tuned. 3. See Monitor menu » Motor: Temperature and » Inputs: Analog2. 4. If the application doesn't use a motor thermistor, Temp Compensation and Temp Cutback should be programmed Off.	<i>Set:</i> Motor temperature is at or above the Temperature Hot parameter setting. <i>Clear:</i> Bring the motor temperature within range.
29	Motor Temp Sensor Fault <i>MaxSpeed reduced (LOS, Limited Operating Strategy), and motor temperature cutback disabled.</i>	X	X	1. Motor thermistor is not connected properly. 2. If the application doesn't use a motor and motor thermistor, Motor Temp Sensor Enable should be programmed Off. 3. See Monitor menu » Motor: Temperature and » Inputs: Analog2.	<i>Set:</i> Motor thermistor input (pin 8) is at the voltage rail (0 or 10V). <i>Clear:</i> Bring the motor thermistor input voltage within range.
31	Coil1 Driver Open/Short ShutdownDriver1.	X	X	1. Open or short on driver load. 2. Dirty connector pins. 3. Bad crimps or faulty wiring.	<i>Set:</i> Main contactor driver (pin 6) is either open or shorted. This fault can be set only when Main Enable = Off. <i>Clear:</i> Correct open or short, and cycle driver.

CALIBRATION & PROGRAMMING

C O D E	PROGRAMMER LCD DISPLAY	T P		POSSIBLE CAUSE	SET/CLEAR CONDITIONS
		T	P		
36	Encoder Fault <i>ShutdownEMBrake.</i>	X	X	1. MotorCoil3 Driver Open/Short ShutdownDriver3. encoder failure. 2. Bad crimps or faulty wiring. 3. See Monitor menu » Motor: Motor RPM.	<i>Set:</i> Motor encoder phase failure detected. <i>Clear:</i> Cycle KSI.
37	Motor Open <i>ShutdownMotor;</i> <i>ShutdownMainContactor;</i> <i>ShutdownEMBrake;</i> <i>ShutdownThrottle;</i> <i>FullBrake;</i> <i>ShutdownPump.</i>	X	X	1. Motor phase is open. 2. Bad crimps or faulty wiring.	<i>Set:</i> Motor phase U, V, or W detected open. <i>Clear:</i> Cycle KSI.
38	Main Contactor Welded <i>ShutdownMotor;</i> <i>ShutdownMainContactor;</i> <i>ShutdownEMBrake;</i> <i>ShutdownThrottle;</i> <i>FullBrake;</i> <i>ShutdownPump.</i>	X	X	1. Main contactor tips are welded closed. 2. Motor phase U or V is disconnected or open. 3. An alternate voltage path (such as an external precharge resistor) is providing a current to the capacitor bank (B+ connection terminal).	<i>Set:</i> Just prior to the main contactor closing, the capacitor bank voltage (B+ connection terminal) was loaded for a short time and the voltage did not discharge. <i>Clear:</i> Cycle KSI
39	Main Contactor Didn't close <i>ShutdownMotor;</i> <i>ShutdownMainContactor;</i> <i>ShutdownEMBrake;</i> <i>ShutdownThrottle;</i> <i>FullBrake;</i> <i>ShutdownPump</i>	X	X	1. Maincontactor did not close. 2. Main contactor tips are oxidized, burned, or not making good contact. 3. External load on capacitor bank (B+ connection terminal) that prevents capacitor bank from charging. 4. Blown B+ fuse.	<i>Set:</i> With the main contactor commanded closed, the capacitor bank voltage (B+ connection terminal) did not charge to B+. <i>Clear:</i> Cycle KSI.
41	Throttle Wiper High <i>ShutdownThrottle.</i>	X	X	1. See Monitor menu >> Inputs: Throttle Pot. 2. Throttle pot wiper voltage too high.	<i>Set:</i> Throttle pot wiper (pin 16) voltage is higher than the high fault threshold (can be changed with the VCL function SETUP POT FAULTS) <i>Clear:</i> Bring throttle pot wiper voltage above the fault threshold.
42	Throttle Wiper Low <i>ShutdownThrottle;</i>	X	X	1. See Monitor menu >> Inputs: ThrottlePot. 2. Throttle pot wiper voltage too high.	<i>Set:</i> Throttle pot wiper (pin 16) voltage is higher than the high fault threshold (can be changed with the VCL function Setup_Pot_Faults). <i>Clear:</i> Bring throttle pot wiper voltage below the fault threshold.
43	Pot2 Wiper High <i>FullBrake.</i>	X		Refer to Curtis	Return Controller to Landoll Corporation for evaluation.
44	Pot2 Wiper Low <i>FullBrake.</i>	X		Refer to Curtis	Return Controller to Landoll Corporation for evaluation.
45	Pot Low Overcurrent <i>ShutdownThrottle.</i> <i>FullBrake</i> <i>ShutdownSteer</i>	X	X	1. See Monitor menu >> Outputs: Pot Low. 2. Combined pot resistance connected to pot low is too low.	<i>Set:</i> Pot low (pin 18) current exceeds 10mA. <i>Clear:</i> Clear pot low overcurrent condition and cycle KSI.

C O D E	PROGRAMMER LCD DISPLAY	T	P	POSSIBLE CAUSE	SET/CLEAR CONDITIONS
46	EEPROM Failure <i>ShutdownMotor; ShutdownMainContactor; ShutdownEMBrake; ShutdownThrottle; ShutdownInterlock;Shutdown Driver1 ShutdownDriver2;Shutdownr iver3; ShutdownDriver4;ShutdownP D; Fullbrake; ShutdownPump; TrimDisable;SevereDual; ShutdownSteer; LOSDual</i>	X	X	1. Failure to write to EEPROM memory. This can be caused by EEPROM memory writes initiated by VCL, by the CAN bus, by adjusting parameters with the programmer, or by loading new software into the controller.	<i>Set:</i> Controller operating system tried to write to EEPROM memory and failed. <i>Clear:</i> Download the correct software (OS) and matching parameter default settings into the controller and cycle KSI.
47	HPD/Sequencing Fault. <i>Shutdown Throttle</i>			1. KSI, interlock, direction, and throttle inputs applied in incorrect sequence. 2. Bad crimp, faulty wiring or KSI switch. See Monitor menu>>Inputs.	<i>Set:</i> HPD (High Pedal Disable) or sequencing fault caused by incorrect sequence if KSI, interlock, direction and throttle inputs. <i>Clear:</i> Reapply correct input sequence.
49	Parameter Change Fault <i>ShutdownMotor; ShutdownEMBrake; Shutdown Throttle; Fullbrake; ShutdownPump</i>	X	X	1. This is a safety fault caused by a change in certain parameter settings so that the vehicle will not operate until KSI is cycled. For example, if a user changes the Throttle Type, this fault will appear and require cycling KSI before the vehicle can operate.	<i>Set:</i> Adjustment of a parameter setting that requires cycling of KSI. <i>Clear:</i> Cycle KSI.
52	Battery Rollout Switch <i>Fault in Left traction controller.</i>				Return Controller to Landoll Corporation for evaluation.
68	VCL Run Time Error <i>ShutdownMotor; ShutdownMainContactor; ShutdownEMBrake; ShutdownThrottle; ShutdownInterlock; ShutdownDriver1; ShutdownDriver2; ShutdownDriver3; ShutdownDriver4; ShutdownPD; FullBrake; ShutdownPump. ShutdownPump: TrimDisable; SevereDual; ShutdownSteer; LOSDual.</i>	X	X	1. VCL code encountered a runtime VCL error. 2. See Monitor menu>>Controller:VCL Error Module and VCL Error. This error can then be compared to the runtime VCL module ID and error code definitions found in the specific OS system information file.	<i>Set:</i> Runtime VCL code error condition. <i>Clear:</i> Edit VCL application software to fix this error condition; flash the new compiled software and matching parameter defaults; cycle KSI.
69	External Supply Out of Range <i>None, unless a fault action is programmed in VCL;</i>	X	X	1. External load on the 5V and 12V supplies draws either too much or too little current. 2. Fault Checking Menu parameters Ext Supply Max and Ext Supply Min are mistuned. 3. See Monitor menu>>Outputs: Ext Supply Current.	<i>Set:</i> The external supply current (combined current used by the 5V supply [pin 26] and 12V supply [pin 25]) is either greater than the upper current threshold or lower than the low current threshold. The two thresholds are defined by the External Supply Max and External Supply Min parameter settings. <i>Clear:</i> Bring the external supply current within range.

CALIBRATION & PROGRAMMING

C O D E	PROGRAMMER LCD DISPLAY	T	P	POSSIBLE CAUSE	SET/CLEAR CONDITIONS
71	OS General <i>ShutdownMotor;</i> <i>ShutdownMainContactor;</i> <i>ShutdownEMBrake;</i> <i>ShutdownThrottle;</i> <i>ShutdownInterlock;</i> <i>ShutdownDriver1;ShutdownD</i> <i>river2;</i> <i>ShutdownDriver3;ShutdownD</i> <i>river4; ShutdownPD;</i> <i>FullBrake:Shutdown Pump;</i> <i>TrimDisable;</i> <i>SevereDual;Shutdown Steer;</i> <i>LOSDual</i>	X	X	1. Internal Controller fault.	<i>Set:</i> Internal controller fault detected. <i>Clear:</i> Cycle KSI.
72	PDO Timeout <i>Shutdown Interlock;</i> <i>CAN NMT State set to</i> <i>Pre-operational</i>	X	X	Time between CAN OPDO messages received exceeded the PDO Timeout Period.	<i>Set:</i> Time between CAN PDO messages received exceeded the PDO Timeout Period. <i>Clear:</i> Cycle KSI or receive CAN NMT message
73	Stall Detected <i>ShutdownMotor;</i> <i>SevereDual;</i> <i>ShutdownEMBrake;</i> <i>Control Mode changed to</i> <i>LOS (Limited Operating</i> <i>Strategy)</i>	X	X	1. Stalled motor. 2. Motor encoder failure. 3. Bad crimps or faulty wiring. 4. Problems with power supply for the motor encoder. 5. See Monitor menu>>Motor: Motor RPM.	<i>Set:</i> No motor encoder movement detected. <i>Clear:</i> Either cycle KSI, or detect valid motor encoder signals while operating in LOS mode and return Throttle Command=) and Motor RPM=0.
74	Fault On other Traction Controller <i>For information on this fault,</i> <i>plug the programmer into the</i> <i>other controller.</i>	X	X	1. A fault is active on the other traction controller.	<i>Set:</i> In a Dual Drive traction system, any fault in the other traction controller will cause this fault to be set. <i>Clear:</i> Clear all the active faults in the other traction controller.

C O D E	PROGRAMMER LCD DISPLAY	T	P	POSSIBLE CAUSE	SET/CLEAR CONDITIONS
75	Dual Severe Fault <i>ShutdownMotor; ShutdownMainContactor ShutdownEMBrake; ShutdownThrottle; FullBrake; Shutdown Pump Other controller: Same effects as this controller.</i>	X	X	1. Both traction controllers have active severe faults and therefore both will be disabled.	<i>Set:</i> A severe fault in each traction controller will cause this fault to be set. <i>Clear:</i> Correct the severe fault(s) in either controller to clear the Dual Severe Fault; of course, you will want to clear all faults on both controllers.
91	VCL/OS Mismatch <i>ShutdownMotor; ShutdownMainContactor; ShutdownEMBrake; ShutdownThrottle; ShutdownInterlock; ShutdownDriver1; ShutdownDriver2; ShutdownDriver3; ShutdownDriver4; ShutdownPD; FullBrake; ShutdownPump</i>			1.The VCL software in the controller does not match the OS software in the controller.	<i>Set:</i> VCL and OS software do not mach when KSI cycles, a check is made to verify that they match and a fault is issued when they don't. <i>Clear:</i> Download the correct VCL and OS software into the computer.
91	VCL/OS Mismatch <i>ShutdownMotor; ShutdownMainContactor; ShutdownEMBrake; ShutdownThrottle; ShutdownInterlock; ShutdownDriver1; ShutdownDriver2; ShutdownDriver3; ShutdownDriver4; ShutdownPD; FullBrake; ShutdownPump</i>			1.The VCL software in the controller does not match the OS software in the controller.	<i>Set:</i> VCL and OS software do not mach when KSI cycles, a check is made to verify that they match and a fault is issued when they don't. <i>Clear:</i> Download the correct VCL and OS software into the computer.
93	Encoder LOS <i>(LimitedOperatingStrategy). Enter LOS control mode.</i>			1. Limited Operating Strategy (LOS) control mode has been activated, as a result of either an Encoder Fault (Code 36) or a Stall Detect Fault (Code 73). 2. Motor encoder failure. 3.Bad crimps or faulty wiring. 4. Vehicle is stalled.	<i>Set:</i> Encoder Fault (Code 36) or Stall Detect Fault (Code 73) was activated, and Brake or Interlock has been applied to activate LOS control mode, allowing limited motor control. <i>Clear:</i> Cycle KSI or, if LOS mode was activated by the Stall Fault, clear by ensuring encoder senses proper operation, Motor RPM=0, and Throttle Command=0.
98	Illegal Model Number <i>ShutdownMotor; ShutdownMainContactor; ShutdownEMBrake; ShutdownThrottle; FullBrake; ShutdownPump.</i>	X	X	1. Model_Number variable contains illegal value (not 1234, 1236, 1238, or 1298). 2. Software and hardware do not match. 3. Controller defective.	<i>Set:</i> Illegal Model_Number variable; when KSI cycles, a check is made to confirm a legal Model_Number, and a fault is issued if one is not found. <i>Clear:</i> Download appropriate software for your controller model.
99	Dualmotor Parameter Mismatch <i>ShutdownMotor; ShutdownMainContactor; ShutdownEMBrake; ShutdownThrottle; FullBrake; ShutdownPump.</i>	X		1. Dual Motor Enable parameter set On and Control Mode Select parameter not set to 1 (Speed Mode Express) or 2 (Speed Mode).	<i>Set:</i> When the Dual Drive software is enabled, the controller must be set to either Speed Mode Express or Speed Mode; otherwise this fault is set. <i>Clear:</i> Adjust parameters to appropriate values for your application and cycle KSI.

Controller Maintenance

There are no user serviceable parts in the Curtis 1234/36/38 controllers. No attempt should be made to open, repair, or modify the controller. Modifying the controller will void the warranty. It is recommended that the controller and connection be kept clean and dry and that the controller's fault history file be checked and cleared during service.

Controller Cleaning

Periodically cleaning the controller exterior will help protect it against corrosion and possible electrical problems created by dirt that is part of the operating environment and that normally exists in battery powered systems. When working around any battery powered system, proper safety precautions should be taken. These include, but are not limited to: proper training, wearing eye protection, and avoiding loose clothing and jewelry.

IMPORTANT

Never use a pressure washer to clean the controller.

Use the following cleaning procedure for routine maintenance:

1. Remove power by disconnecting the battery.
2. Discharge the capacitors in the controller by connecting a load across the controller's **B+** and **B** terminals.
3. Remove any dirt or corrosion from the power and signal connector areas. The controller should be wiped clean with a moist rag. Dry it before reconnecting the battery.
4. Make sure the connections are tight.

Programmer Menus

The programmers have six menus, which in turn lead to nested submenus.

- **Program** — provides access to the programmable parameters.
- **Monitor** — presents real-time values during vehicle operation; these include all inputs and outputs, as well as the mapped throttle values and conditioned throttle requests.
- **Faults** — presents diagnostic information and also a means to clear the fault history file.
- **Functions** — provides access to the controller-cloning commands and to the "reset" command.
- **Information** — displays data about the host controller, model and serial numbers, date of manufacture, hardware and software revisions, and itemization of other devices that may be associated with the controller's operation.
- **Programmer Setup** — displays data about the programmer: model and serial numbers, and date of manufacture.

Supplier Provided Documentation - Mast

Disclaimer:

The documentation provided here within Chapter 5, "Supplier Provided Documentation", has been appended to this Landoll Maintenance Manual for reference only.

The specific contents of this information is not the responsibility of Landoll Corporation or any of its affiliates.

Lift Technologies Inc.

30D-60D 3-Stage Masts

Table of Contents - page 4

Proceed to the above "Table of Contents" starting on page 4, to the Mast Installation, Periodic Maintenance, Troubleshooting and Service instructions as required.

Mast Service Chapter

30D/35D/40D/50D/55D/60D

Full Free Lift 3-Stage Mast - MT

Contents

	Page
INTRODUCTION, Section 1	4
Introduction	4
Special Definitions	4
INSTALLATION INSTRUCTIONS, Section 2	5
Truck System Requirements	5
Mounting Bracket Installation	5
Mast Installation	6
Inspection and Adjustments	7
Chain Inspection and Tension	7
Main Lift Chain Adjustment	7
Free Lift Chain Adjustment	7
Free Lift Cylinder Supply Hose Tracking Adjustment	8
Upright Rail Lubrication	8
Cylinder Bleeding	8
Mast Skewing	8
Internal Reeving Installation	9
PERIODIC MAINTENANCE, Section 3	16
TROUBLESHOOTING, Section 4	17
SERVICE, Section 5	18
Mast Removal	18
Cylinders	19
2000 PSI Main Lift Cylinder Description	19
2600 PSI Main Lift Cylinder Description	20
Free Lift Cylinder Description	21
Cylinder Operation	22
Main Lift Cylinder Removal- Mast on Floor	24
Free Lift Cylinder Removal- Mast on Floor	25
Free Lift Cylinder Removal- Mast on Truck	26
Main Lift Cylinder Service	27
Free Lift Cylinder Service	28
Piston Removal	29
2600 PSI Cylinder Bleeding	29
Valve	29
Valve Cartridge Service	29
Carriage	30
Description	30
Carriage Removal- Mast on Truck	31
Carriage Removal- Mast on Floor	32
Carriage Inspection	33
Mast Uprights	34
Upright Description	34
Upright Operation	35
Upright Disassembly	36
Upright Inspection	37
Upright Reassembly	38
Mast Skewing	41
Chains	42
Inspection and Tension	42
Measuring Chain Stretch	43
Main Lift Chain Adjustment	43
Free Lift Chain Adjustment	43
Main Lift Chain Service	44
Free Lift Chain Service	44

Section 1 Introduction

1.1 Introduction

This manual provides the installation instruction, periodic maintenance, troubleshooting and service procedures for the Lift Tek Series masts.

In any communication about the mast, refer to the mast serial number stamped in the nameplate. If the nameplate is missing, these numbers are also stamped on the left-hand upper cheekplate. See Figure 1.



WARNING: Do not install a Lift Tek Mast on a truck with a capacity greater than the truck rated capacities shown below

TRUCK CAPACITY AT 24IN. (610 mm) LOAD CENTER

30D	35D	40D	50D	55D	60D
3000 lbs.	3500 lbs.	4000 lbs.	5000 lbs.	5500 lbs.	6000 lbs.
(1361 kg)	(1585 kg)	(1812 kg)	(2268 kg)	(2491kg)	(2718 kg)

Modifications and additions which affect capacity or safe operation shall not be performed without prior written approval from Lift Technologies per ANSI B56. 1.

1.2 Special Definitions

WARNING

A statement preceded by  **WARNING** is information that should be acted upon to prevent **bodily injury**. A **WARNING** is always inside a ruled box.

CAUTION

A statement preceded by **CAUTION** is information that should be acted upon to prevent **machine damage**.

IMPORTANT

A statement preceded by **IMPORTANT** that possesses special significance.

NOTE

A statement preceded by **NOTE** is information that is handy to know and may make your job easier.

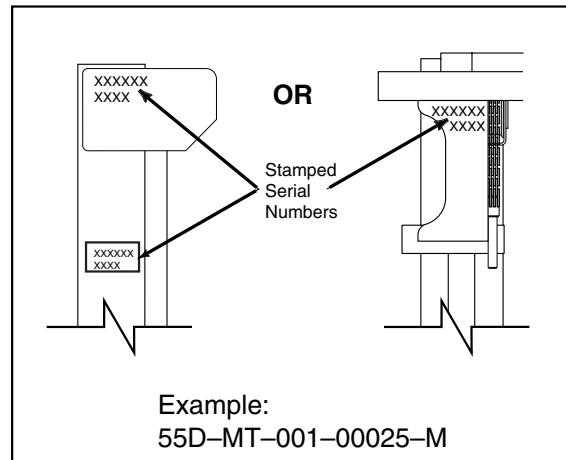

Figure 1. Serial Mast Number Location

2 Installation Instructions

2.1 Truck System Requirements

To achieve maximum lifting capacity of the mast, the truck relief valve should be set to relieve at the pressure indicated in the chart below. This chart also indicates the hose fitting size to use between the truck control valve and masts valve.

Lift Tek Mast	Relief Pressure	Hose Size	Fitting* Size
30D/35D/40D	2000 psi	No. 8 min.	No. 8 min.
30D/35D/40D	2600 psi	No. 6 min.	No. 6 min.
50D/55D/60D	2600 psi	No. 8 min.	13/32 in. Orifice

* Valve inlet port is 3/4 in. SAE O-ring. See Figure 2.

WARNING: For proper truck stability or to prevent interference, tilt restriction may be required. Contact the truck manufacturer.

IMPORTANT: Lift Tek Masts are compatible with SAE 10W petroleum base oil per Mil. Spec. MIL-0-5606 or MIL-0-2104 B only. Use of synthetic or aqueous base hydraulic oil is not recommended. If fire resistant hydraulic oil must be used, contact Lift Tek.

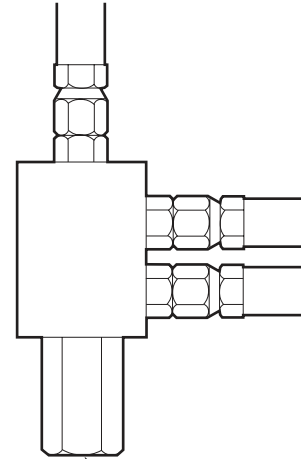

**Valve Inlet Port
3/4 in. SAE O-ring**

Figure 2. Valve inlet Port.

2.2 Mounting Bracket Installation

If it is necessary to install mounting brackets and crossmembers to fit your lift truck, consult with the nearest Lift Tek Service Department listed on the back cover. You must supply dimensions **A** through **F** shown in Figure 3. Failure to install the correct brackets and crossmembers can result in mast structural failure, bodily injury and loss of warranty.

WARNING: Failure to install the correct brackets and crossmembers can result in mast structural failure, bodily injury and loss of warranty.

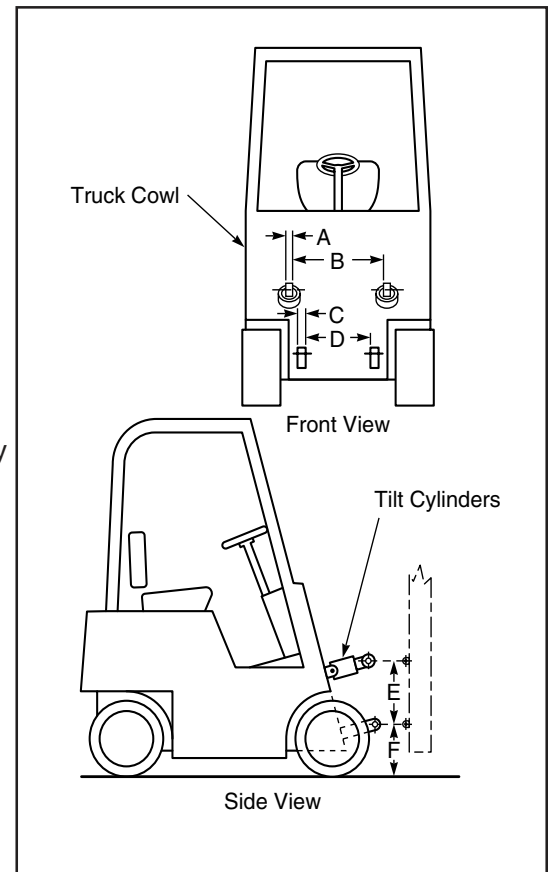

Figure 3. Determining Mounting Bracket Location.

2.3 Mast Installation

1. **Raise** and block the front end of the truck 1ft. (30 cm) per ANSI B56.1 or drive the truck over a service pit.
2. Install the bearings to lower the axle mounts.
3. Lubricate the bearing surfaces of the lower axle and tilt cylinder mounting brackets with chassis grease.
4. Lift the mast using an overhead hoist with chain hooks attached to the cheekplate lifting holes. Position the mast by lowering the axle mounts on the truck axle. Install the mount caps and capscrews. Tighten the capscrews to the truck manufacturer's torque specifications.

IMPORTANT: Prior to connecting the tilt cylinders to the mast, make sure the cylinders "bottom" evenly. Adjust the tilt cylinders to prevent the mast from "racking" during tilting. Refer to your truck service manual for procedures.

5. Connect the lift truck hose to the mast valve.
6. Connect the tilt cylinders to the mast anchor brackets. Tighten the pin capscrews to the truck manufacturer's torque specifications.

NOTE: Use as few fittings as possible and always use 45° fittings instead of 90° fittings. Keep the hose lengths to a minimum. Avoid sharp bends or pinch points when routing the hose.

Contact Lift Tek if additional fittings are required. See back cover.

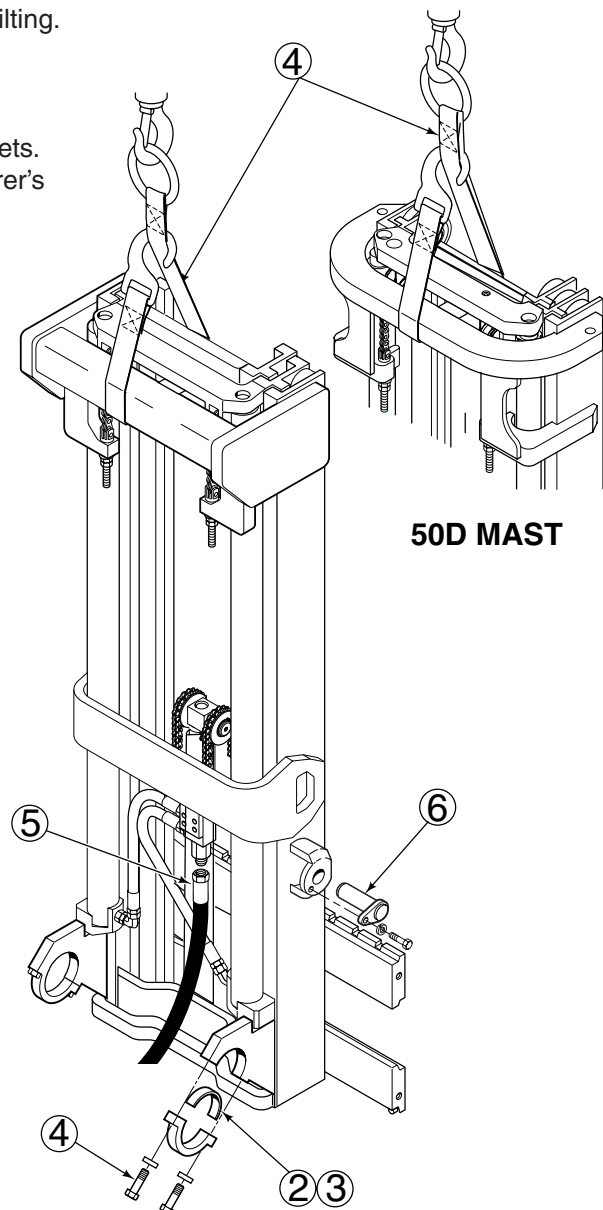

Figure 4. Mast Installation.

Section 2 Installation Instructions

2.4 Inspection and Adjustments

2.4-1 Chain Inspection and Tension

The hoist Chains have been factory lubricated using heat and pressure to force the lubricant thoroughly into the chain links. Avoid removal or contamination of this factory applied lubricant. **Do not wash, sand blast, etch, steam clean, or paint the chains for internal mast installation.**

The chains must be adjusted with equal tension to ensure proper load distribution and mast operation. To determine equal tension, extend the unload mast to put the chains under tension. Press the center of a strand of chain with your thumb, then press at the same place on the other chain of the pair. Each chain in a pair should have equal "give". If they do not have equal tension, perform the hoist chain adjustments described in Section 5.6-3 and 5.6-4.

2.4-2 Main Lift Chain Adjustment

SEE SECTION 5.6-4.

2.4-3 Free Lift Chain adjustment

SEE SECTION 5.6-6.

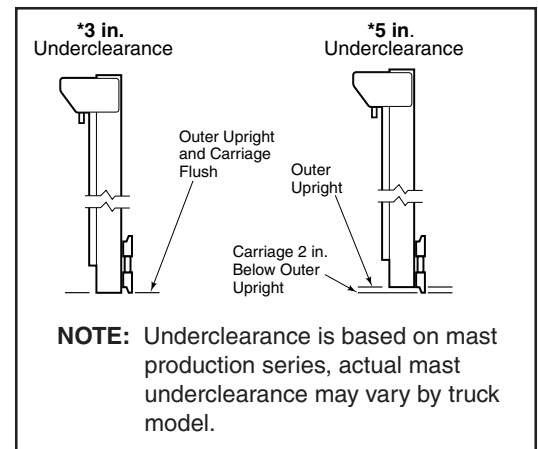

Figure 5. Upright and Carriage Position.

2.4-4 Free lift Cylinder Supply Hose Tracking Adjustment

Make sure the cylinder supply hose is not twisted and travels evenly in the hose guide. Check the hose to be sure it is not scuffing. Adjust the hose by loosening the hose end connection at the valve and twist the hose. Tighten the hose end while holding the hose in place. See Figure 10. Tension on the hose can be adjusted by using a different set of bracket holes. Use the holes that place a small amount of tension on the hose.

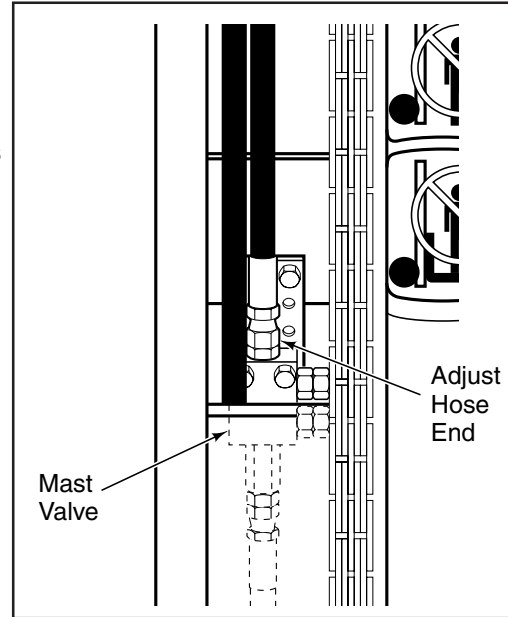

Figure 6. Free Lift Cylinder Supply Hose Adjustment.

2.4-5 Upright Rail Lubrication

Lubricate the full length of each upright rail with chassis lube or Kendall SR-12X as shown in Figure 6.

2.4-6 Cylinder Bleeding SEE SECTION 5.2-11.

2.4-7 Mast Skewing

Check for mast skewing as described in Section 5.5-6.

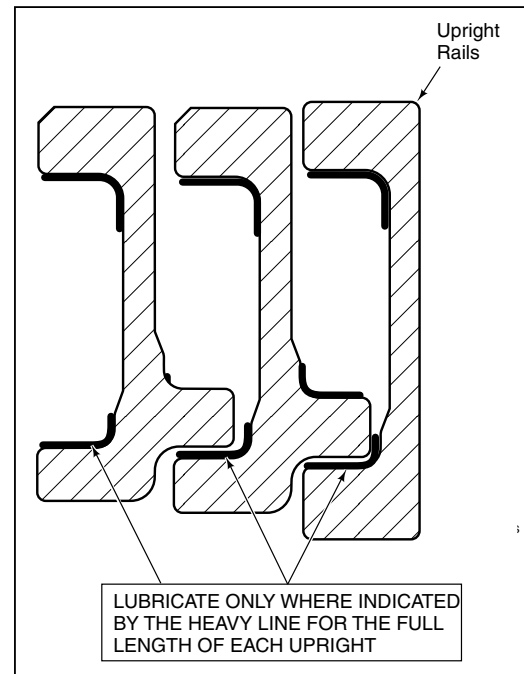

Figure 7. Channel lubrication.

2 Installation Instructions

2.5

Internal Reeving - Hi-Vis Installation 30D/35D/40D and 50D

1. Install the shafts, sheaves and hose guards to the crosshead center plate. Leave the capscrew and nut finger tight to allow hose installation.

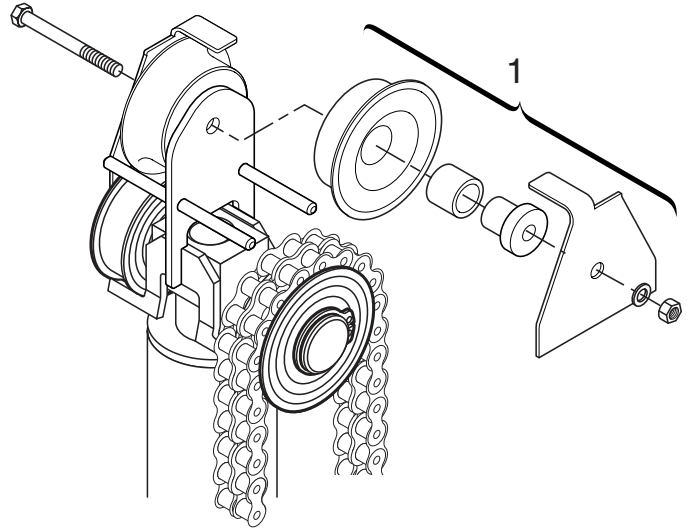

Figure 8 . Crosshead Assembly.

2. Install the carriage bracket to the tabs between the carriage sideplates. Leave the capscrews finger tight.

3. Install fittings to bracket.

- * Single Function - Install the fittings to the left or right side location. Tighten the fittings finger tight.
- * Double Function - Install the fittings to the left and right side location. Tighten the fittings finger tight.

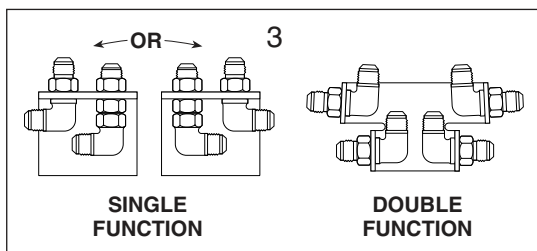

Figure 8. Carriage Bracket Assembly. MA0281.iii

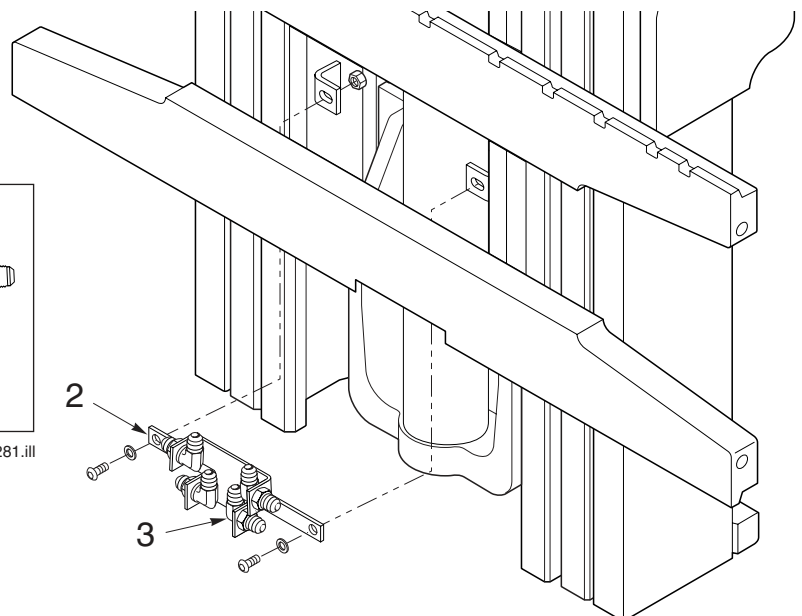

Figure 9. Carriage bracket Installation.

2 Installation Instructions

Internal Reeving - Hi-Vis

Installation 30D/35D/40D and 50D

4. Install the brackets, hose clamps and sheaves to the uprights. Tighten the bracket capscrews to a torque of 38 ft.- lbs. (51 Nm).
5. Completely lower the carriage. Route the hoses down behind the top carriage bar to the carriage bracket fittings. Connect the hoses fittings to the carriage fittings and tighten.
6. Loosen the crosshead coverplate capscrew. Route the hoses up over the crosshead sheaves. Orient the hoses with the natural curve over the sheaves.
7. Route the hoses down between the free lift cylinder and middle inner crossmember to the bracket behind the free lift cylinder. The hoses route through the wire loop then underneath the lower inner crossmember. Assemble the clamp and hoses, then pull down on the hoses with 80 lbs. force to remove slack. Tighten the clamp capscrews to a torque of 8 ft.-lbs (11Nm).

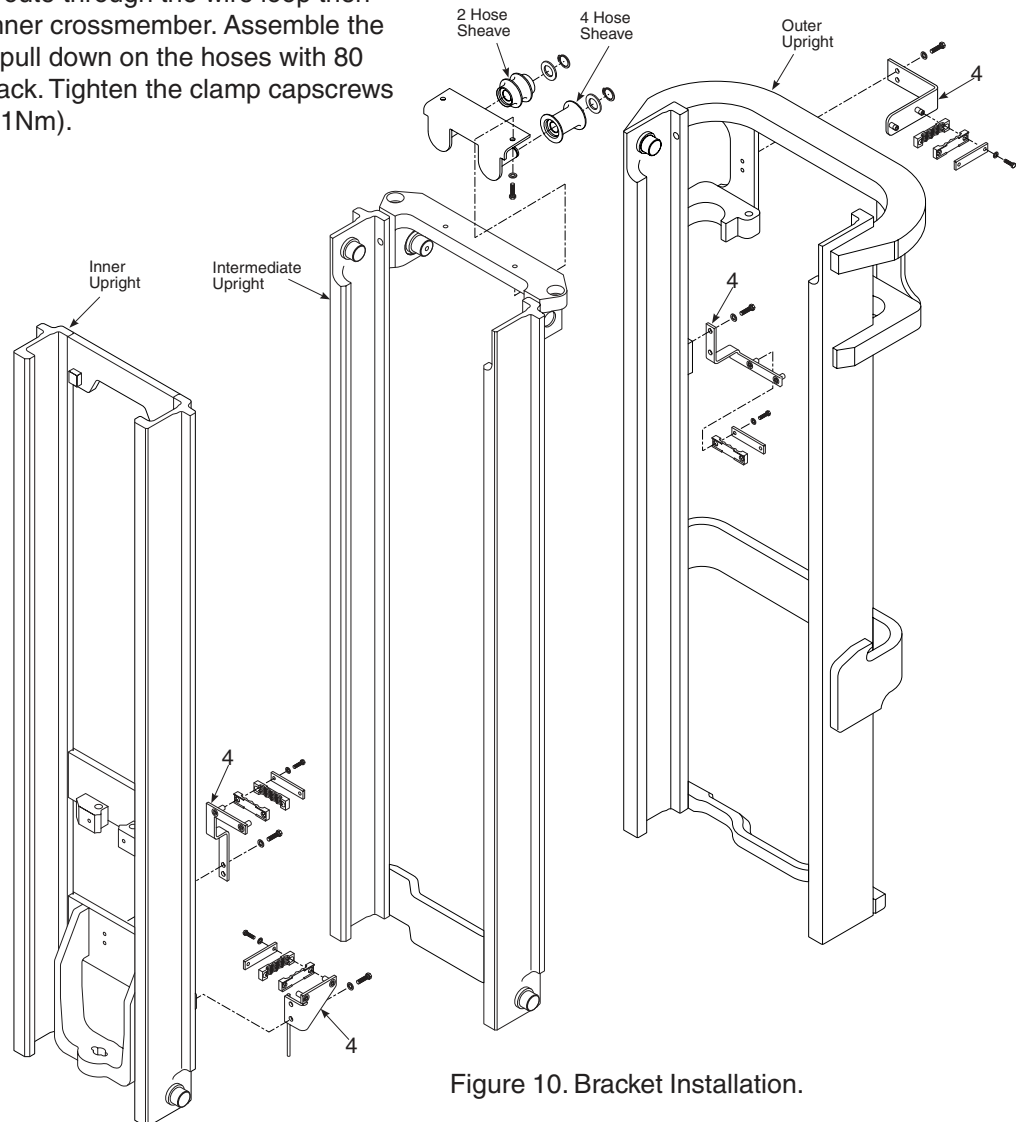

Figure 10. Bracket Installation.

2 Installation Instructions

Internal Reeving - Hi-Vis

Installation 30D/35D/40D and 50D

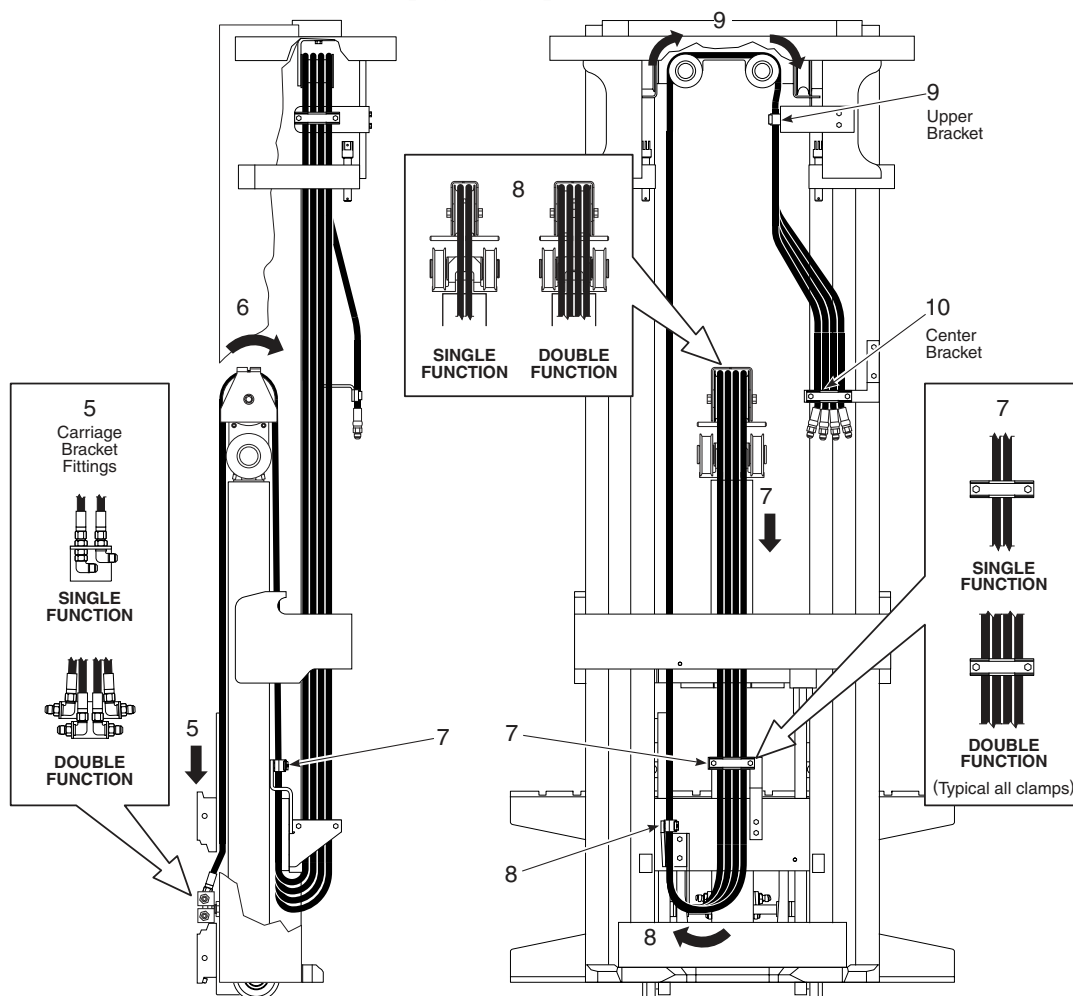

Figure 11. Hose Routing.

8. Route the hoses under the lower inner crossmember to loop up to the lower hose bracket. Install the hose clamps leaving the capscrews finger tight. Align the hoses under the crossmember and into the clamp. Tighten the clamp capscrews to a torque of 8 ft.-lbs. (11Nm).
9. Route the hoses up to and over the upper hose sheaves and then down to the upper hose bracket. Assemble the clamp and hoses to the upper bracket leaving the capscrews finger tight. Starting with the outer hose, pull down on the hoses with 80 lbs. of force to remove slack, then tighten the clamp capscrews to a torque of 8 ft.-lbs. (11Nm).
10. Attach the hose ends to the center hose bracket aligning the hoses with their natural curve. Tighten the clamp capscrews to a torque of 8 ft.-lbs. (11Nm.)
11. Attach the left hand cylinder supply hose and clamp to the outer upright center crossmember. Tighten the clamp capscrew to a torque of 8 ft.-lbs. (11Nm.)

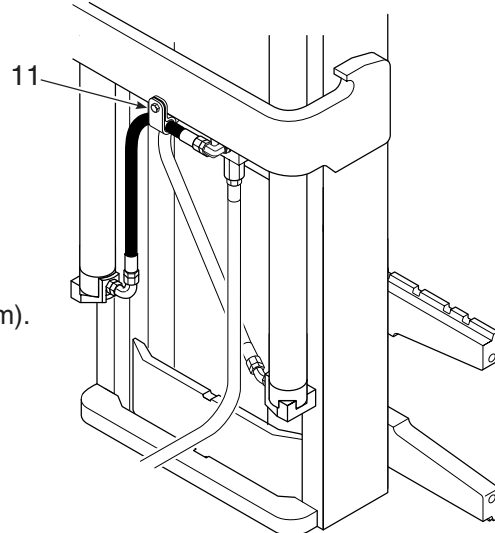

Figure 12. Main Lift Hose.

2 Installation Instructions

Internal Reeving - Hi-Vis

Installation 30D/35D/40D and 50D

12. Tighten the crosshead coverplate capscrew to a torque of 51 ft.-lbs. (70Nm.).
13. Tighten the carriage bracket capscrews to a torque of 46 ft.-lbs. (63 Nm.)
14. Raise and lower the mast slowly through several cycles checking for proper hose alignment, clearances and hose tracking.

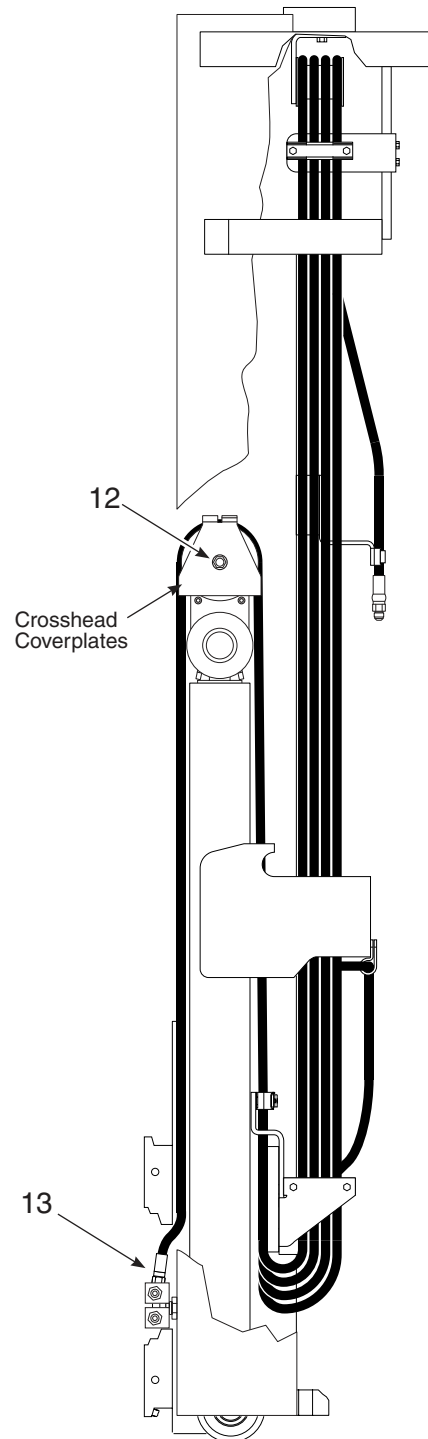

Figure 13. Crosshead Assembly.

2 Installation Instructions

Internal Reeving - Std-Vis Installation 55D/60D

1. Install the reeving brackets to the crosshead. Tighten the capscrews to a torque of 12 ft.-lbs. (17Nm.).
2. Install the rollers and hose guards to the crosshead reeving bracket. Leave the nut finger tight to allow hose installation.

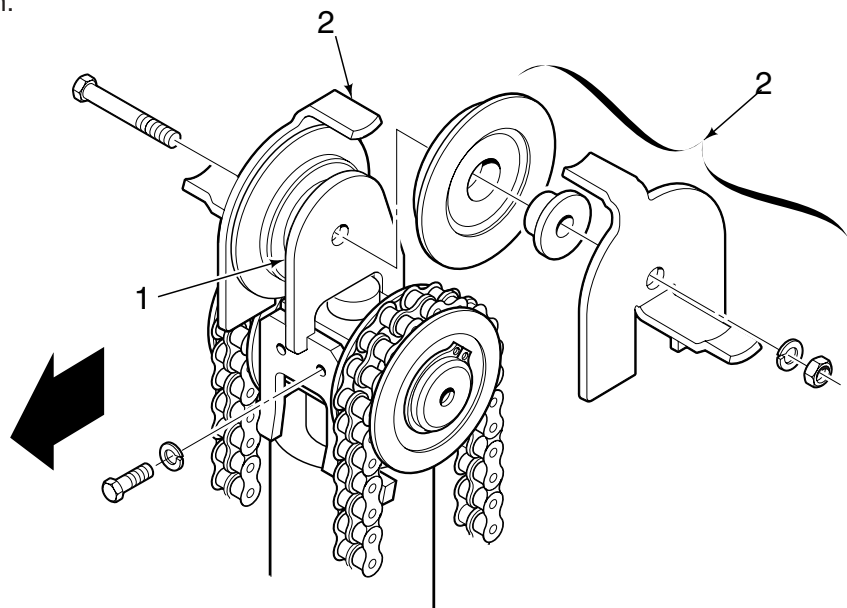

Figure 14. Center Crosshead Sheaves.

3. **Double Function Internal Reeving** - Install the sheaves to the crosshead chain shafts. Leave the capscrews finger tight to allow for hose installation.

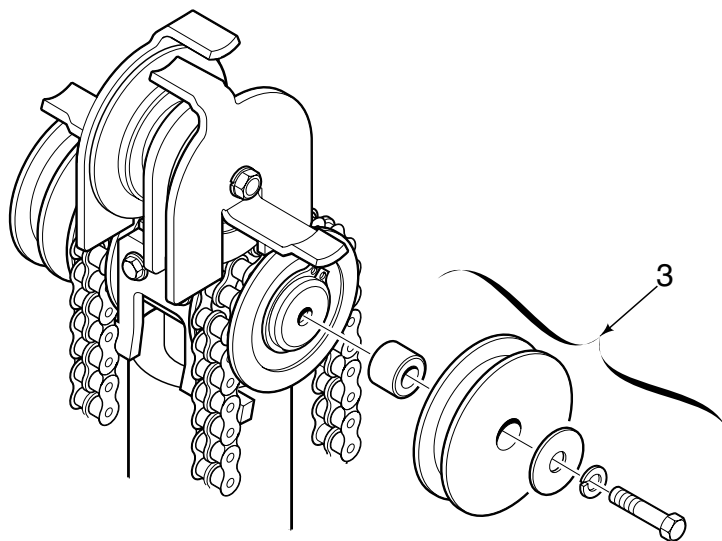

Figure 15. Outer Crosshead Sheaves.

Section 2 Installation Instructions

Internal Reeving - Std-Vis Installation 55D/60D Single Function

1. Install the carriage bracket to the tabs on the carriage side plates. Tighten the nuts to a torque of 38 ft.-lbs. (51Nm.)
2. Install the bulkhead and 90° fitting to the middle two holes in the carriage bracket.
3. Install the hoses to the carriage bracket fittings. Leave the fittings loose.
4. Route the hoses up and over the rollers on the center of the crosshead. Tighten the hose guard capscrew to a torque of 38 ft.-lbs. (51Nm.).



WARNING: Chain and block the uprights and carriage to secure for step 5.

5. Install spacers to the inner crossmember backside tabs.
6. Raise the carriage approximately 8 ft. (240cm). route the hoses downward on the front side of all the crossmembers, then under the tab on the front side of the cylinder support. Feed the hoses backward under the crossmember, around the casting guide upward under the back side.
7. Pull the hose ends to remove hose slack.
8. Remove the existing capscrews from the main lift chain shafts. Install the hose, sheaves, shafts and spacers to the main lift chain shafts. Tighten the capscrews to a torque of 58 ft.-lbs. (79Nm.). Make sure the sheaves rotate freely.
9. Attach the hoses to the brackets and fittings. Leave the fittings loose on the bracket.

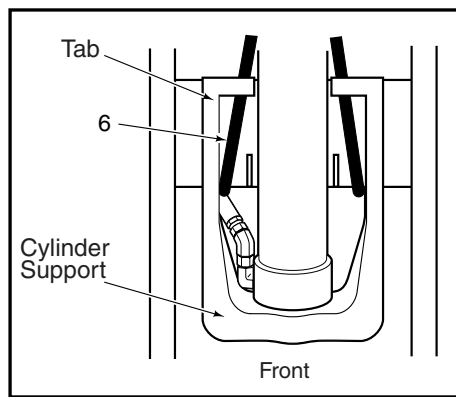
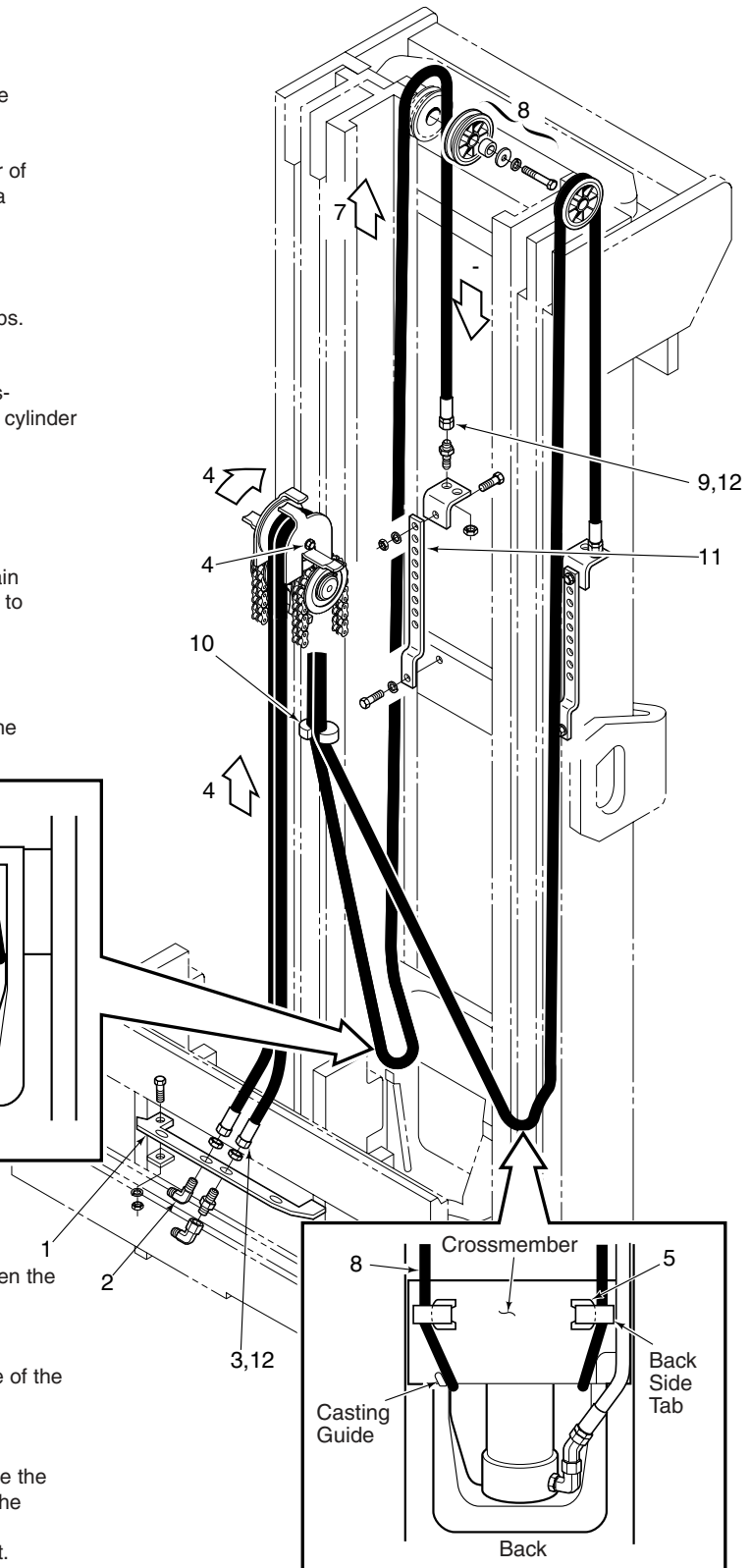

Figure 16. Hose Routing.

10. Install the hose clamps to the hoses half way between the crosshead and lower crossmember.
11. Pull down on the hoses to remove slack and stretch hoses one inch. Install the brackets on the front side of the crossmember using the next hole down. Tighten the capscrew to a torque of 38 ft.-lbs. (51 Nm.).
12. Raise and lower the mast several times to make sure the hoses are tracking correctly. Use the white line on the hose to detect twisting. Adjust the hose ends if required. Tighten fittings making sure they do not twist.



Internal Reeving - Std-Vis

Installation 55D/60D Double Function

1. Install the carriage bracket to the tabs on the carriage side plates. Tighten the nuts to a torque of 38 ft.-lbs. (51Nm.).
2. Install the bulkhead and 90° fitting to the holes in the carriage bracket.
3. Install the hoses to the carriage bracket fittings. Leave the fittings loose.
4. Route the hoses up and over the rollers on the crosshead. Tighten the sheave capscrews to a torque of 38 ft.-lbs. (51Nm.).



WARNING: Chain and block the uprights and carriage to secure for step 5.

5. Raise the carriage approximately 8 ft. (240 cm). Route the hoses downward on the front side of all crossmembers, then under the tab on the front side of the cylinder support. Feed the hoses backward under the crossmember, around the casting guide upward under the back side tabs.
6. Pull the hose ends to remove slack.
7. Remove the existing capscrew from the main lift chain shafts. Install the hoses, sheaves, shaft and spacers to the main lift chain shafts. Tighten the capscrew to a torque of 58 ft.-lbs. (79Nm.). Make sure the sheaves rotate freely.
8. Attach the hoses to the brackets and fittings. Leave the fittings loose on the bracket

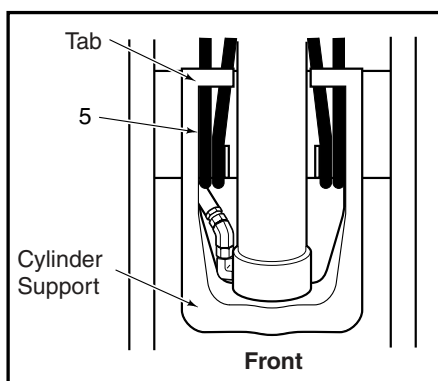
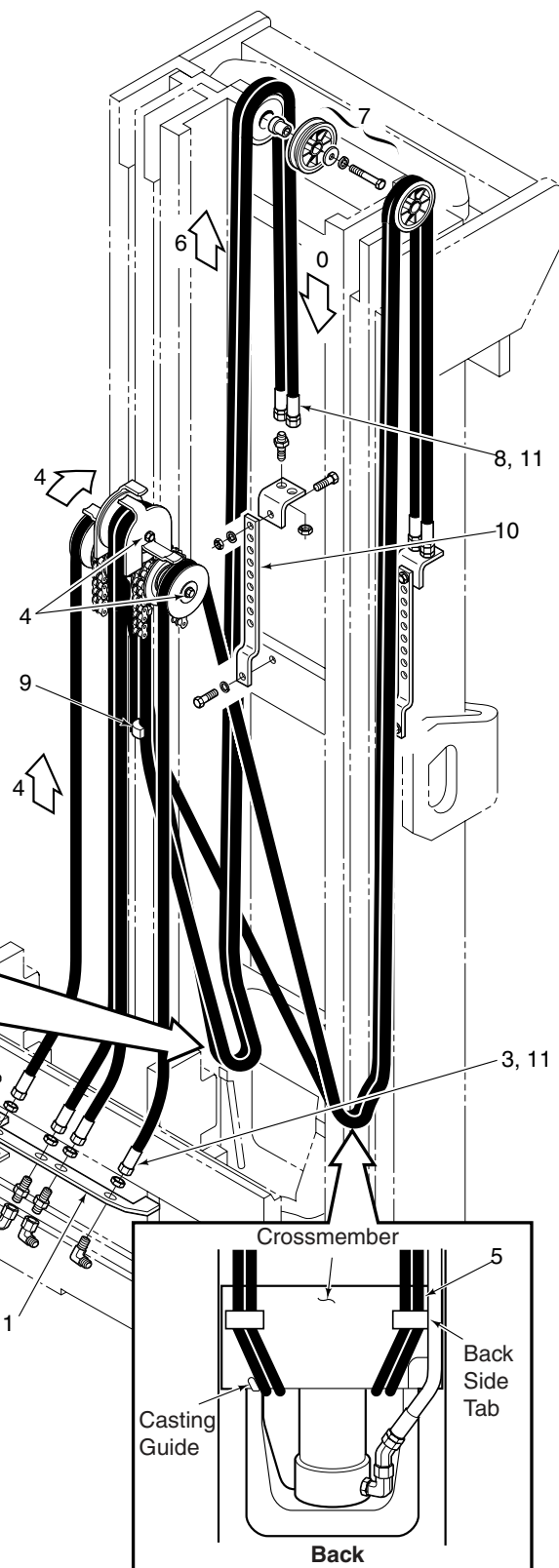

Figure 17. Hose Routing.

9. Install the hose clamp to the two center hoses half way between the crosshead and lower crossmember.
10. Pull down on the hoses to remove slack and stretch the hoses one inch. Install the brackets on the front side of the crossmember using the next hole down. Tighten the capscrew to a torque of 38 ft.-lbs. (51Nm.).
11. Raise and lower the mast several times to make sure the hoses are tracking correctly. Use the white line on the hose to detect twisting. Adjust the hose ends if required. Tighten the fittings making sure they do not twist.



Section 3 Periodic Maintenance

3.1 Periodic Maintenance

For proper operation and an extended service life, your Lift Tek Mast should be inspected and serviced regularly as part of your normal lift truck maintenance schedule according to the following outlines and ANSI B56.1 procedures.

The recommended intervals are for masts operating under normal conditions. If the mast is operating in severe conditions or corrosive atmospheres, the inspections should be performed more frequently.



WARNING: Never work on the mast with a load on the forks or attachment, in the raised position without supports or while anyone is near the lift truck control handles per ANSI B56.1

3.1-1 Daily Inspection

Perform the following at the beginning of each work shift:

1. Extend the carriage a few inches off the ground and make sure the chains are under equal tension. Refer to Section 5.6-3 and 5.6-6 for chain adjustment.
2. Extend the mast to its fullest height to make sure the mast rails and carriage extend freely without binding.
3. While the mast is extended, inspect the upright rails for proper lubrication. Refer to Section 2.4-5 Step for rail lubrication.
4. Make sure the internal reeving hoses (if equipped) travel evenly in the hose guides. Adjust the hose ends if required. Tighten the fittings making sure they do not twist.

100 Hour Inspection

After each 100 hours of lift truck operation, and in addition to the daily inspection:

1. Inspect and lubricate the full length of the chains with SAE 40 wt. oil or Bowman Heavy Load Red Grease.

CAUTION: The chains must be coated with a film of lubricant at all times.

500 Hour Inspection

After each 500 hours of lift truck operation, and in addition to the Daily and 100 Hour Inspection:

1. Each pair of load rollers on the uprights and carriage should be shimmed so that a total side to side clearance no greater than 1/16 in. (1.5 mm) occurs at the tightest point throughout the travel of the member. Pry between the upright and load roller so that the opposite load roller is tight against the upright. Measure the clearance for the pair of rollers at XXX shown. See Figure 18.

2. Check the chains for wear and stretch. Refer to Section 5.6-1 for complete chain inspection.

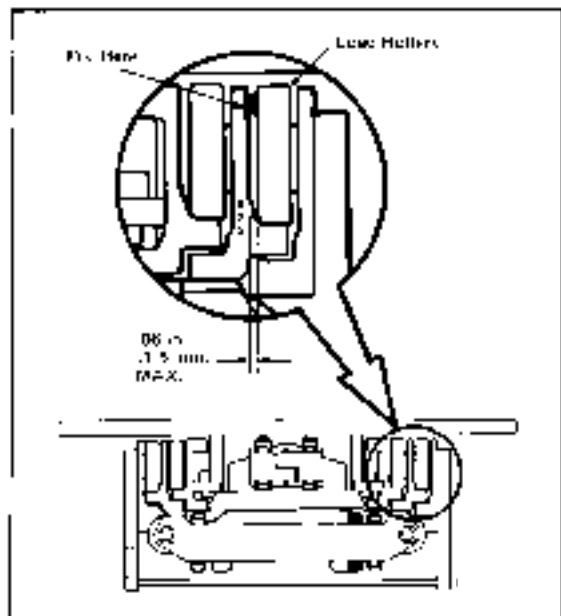

Figure 18. Load Roller Clearances.

4 Troubleshooting

The following table lists problems that may be encountered on your Lift Tek Mast, the probable causes and recommended corrective action that should be taken to restore the mast to normal operating condition.

PROBLEM	PROBABLE CAUSE	SOLUTION
Cylinders don't lift load or won't move		
	Empty	
	a) Plugged inlet hose	a) Unplug hose or replace.
	b) Insufficient oil.	b) Check the truck hydraulic system for correct oil level in tank, defective pump or pump drive, leaks in the lines or disconnect control valve linkage. Repair or replace as necessary.
	c) Bent or jammed plunger.	c) Repair or replace as necessary.
	⚠ WARNING: Extreme care should be used when working on a unit when the carriage (with or without a load) is in the raised position.	
Loaded	a) Plugged piston check valve.	a) Unplug check valve or replace.
	b) Truck relief valve setting low.	b) Raise truck relief setting to specified level.
	c) Over capacity.	c) Reduce load to specified capacity.
	d) Mechanical bind due to bent plunger or bad rollers.	d) Remove mechanical bind by replacing/freeing plunger and rollers.
	⚠ WARNING: Extreme care should be used when working on a unit when the carriage (with or without a load) is in the raised position.	
Cylinders drift-	a) External leak in pressure line.	a) Tighten or replace as necessary.
	b) Truck valve defective-cycle to full lift height to verify.	b) Repair or replace truck valve.
	c) External leaks at retainer.	c) Replace all cylinder seals.
	d) Piston check valve leaking.	d) Replace check valve.
Spongy or jerky action-	a) Sticky or defective truck relief valve.	a) remove and check the truck relief valve. If contaminated oil caused the malfunction, drain and flush the system, change the filter and refill with fresh oil.
	⚠ WARNING: Extreme care should be used when working on a unit when the carriage (with or without a load) is in the raised position.	
	b) Bent or damaged cylinder plunger.	b) Disassemble, check and repair cylinder assembly.
	⚠ WARNING: Extreme care should be used when working on a unit when the carriage (with or without a load) is in the raised position.	
	c) Load rollers not properly adjusted or defective.	c) Adjust or repair as necessary.
	⚠ WARNING: Extreme care should be used when working on a unit when the carriage (with or without a load) is in the raised position.	
	d) Mast channels improperly lubricated.	d) Lubricate mast.
	⚠ WARNING: Extreme care should be used when working on a unit when the carriage (with or without a load) is in the raised position.	
	e) Low Battery charge.	e) Charge battery.
	f) Low pump volume.	f) Install accumulator.
g) Low oil level.	g) Fill oil reservoir.	
h) Insufficient hydraulic tank capacity or baffles.	h) Install larger tank baffles	

Section 5 Service

5.1 Mast Removal

1. Raise and block the front end of the truck 1ft. (30cm) or drive the truck over a service pit.
2. Disconnect the lift truck supply hose from the mast valve. Plug the hose end and cap the valve fitting.



WARNING: Do not stand on or near the mast while suspended by the hoist.

3. Attach overhead hoist with lifting strap routed under all upper crossmembers. Take up slack in the strap.
4. Disconnect the tilt cylinders from the mast anchor brackets. For reassembly, tighten the pin capscrews to the truck manufacturer's torque specifications.
5. Disconnect the mast lower mounts. For reassembly, tighten the capscrews to the truck manufacturer's torque specifications.
6. Lift away the mast.
7. For mast installation, refer to Section 2.1.



WARNING: Do not stand the mast upright unless it is chained to a support.

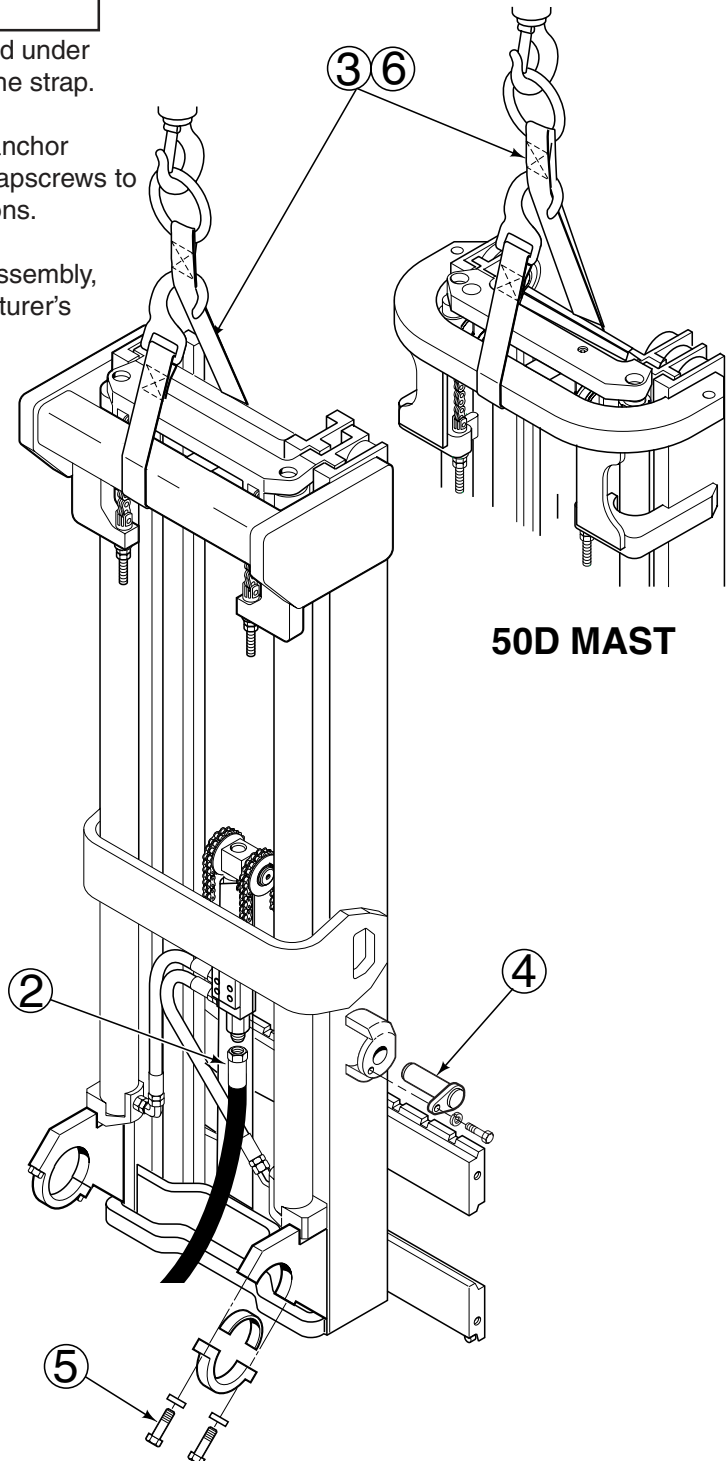

Figure 19. Mast Removal

Section 5 Service

5.2 Cylinders

5.2-1 2000 PSI Main Lift Cylinder Description

The main lift cylinders are single stage piston type cylinders. They consist of a shell and a telescoping plunger/piston assembly. During extension oil pressure is acting against the full piston area. The truck hoist control valve holds the cylinder in place once extension has stopped.

The shell is internally threaded at the top end to hold the retainer. The retainer seals provide a high-pressure hydraulic seal against the plunger. The retainer also limits the upward stroke of the plunger.

A piston is attached to the bottom end of the plunger. The piston seal provides a high-pressure hydraulic seal against the shell. A check valve is located in the bottom of the piston. The check valve allows residual oil between the shell and plunger to escape when the cylinder is extending.

A hydraulic fuse/cushion valve is located in the cylinder port. In case of a hose failure between the lowering control valve and cylinders, the fuse limits the lowering speed of the cylinder. The valve also cushions the piston when the cylinder nears the fully lowered position.

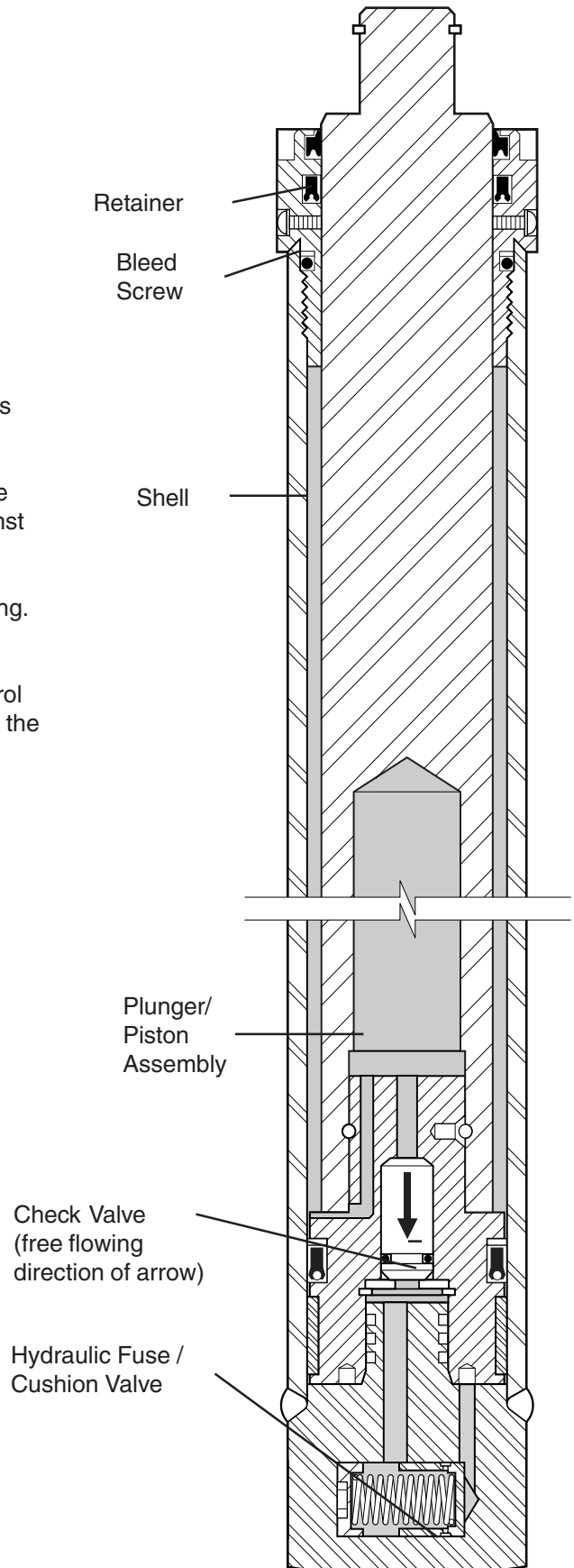

Figure 20. 2000 PSI Cylinder

Section 5 Service

5.2-2

2600 PSI Main Lift Cylinder Description

The main lift cylinders are a single stage displacement type cylinders. They consist of a shell and a telescoping plunger/piston assembly. During extension the oil pressure is acting against the plunger outer diameter due to the internal porting through the piston. The piston seals do not affect cylinder extension. The truck hoist control valve holds the cylinders in place once extension has stopped.

The shell is internally threaded at the top end to hold the retainer. The retainer seals provide a high-pressure hydraulic seal against the plunger. The retainer also limits the upward stroke of the plunger.

A piston is attached to the bottom end of the plunger. The piston seal provides a high-pressure hydraulic seal against the shell that engages the cushion valve when the cylinder is fully lowered.

A hydraulic fuse/cushion is located in the cylinder port. In case of a hose failure between the lowering control valve and cylinders, the fuse limits the lowering speed of the cylinder. The valve also cushions the piston when the cylinder nears the fully lowered position.

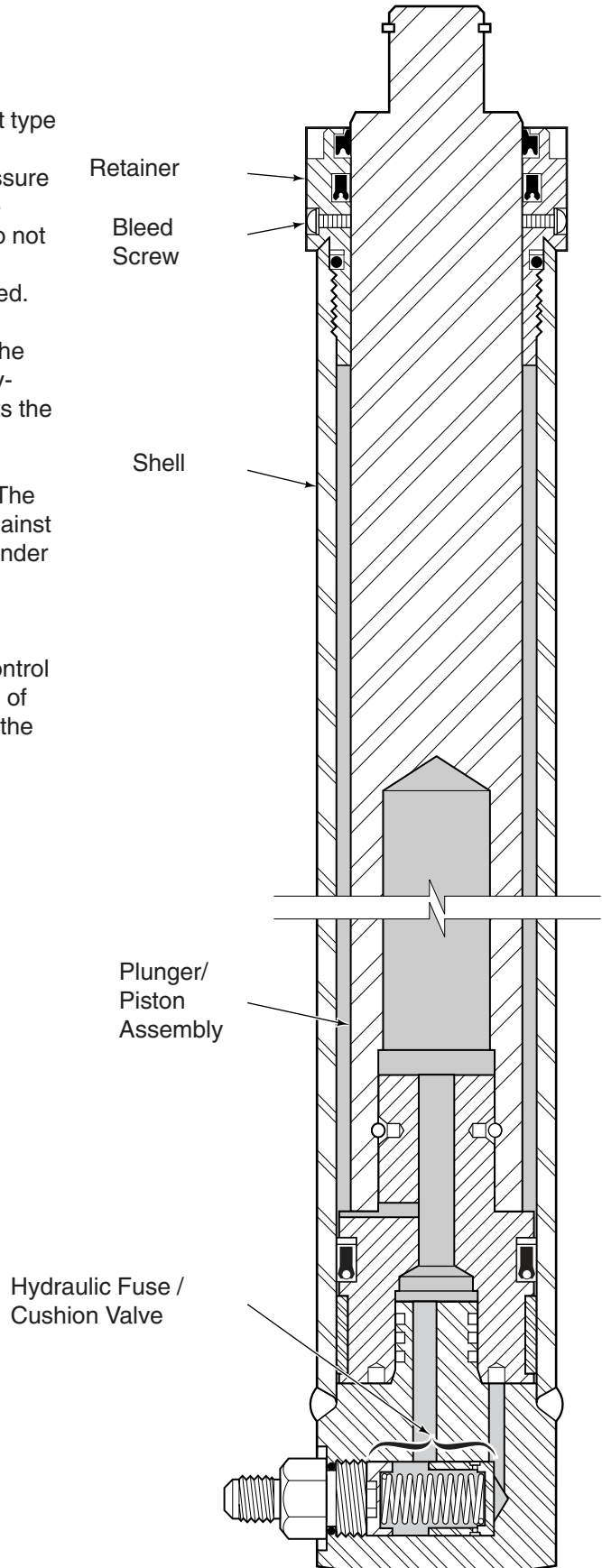

Figure 21. 2600 PSI Cylinder

Section 5 Service

5.2-3 Free Lift Cylinder Description

The 2000 and 2600 psi free lift cylinders are single stage piston type cylinders. They consist of a shell and a plunger/piston assembly. During extension the oil pressure is acting against the full piston area. The truck hoist control valve holds the cylinder in place once extension has stopped.

The shell is internally threaded at the top end to hold the retainer. The retainer seal provide a high-pressure hydraulic seal against the plunger. The retainer also limits the upward stroke of the plunger.

A piston is attached to the bottom end of the plunger. The piston seal provides a high-pressure hydraulic seal against the shell. A check valve is located in the bottom on the piston. The check valve allows residual oil between the shell and plunger to escape when the cylinder is extending.

A hydraulic fuse/cushion valve is located in the cylinder port. In case of a hose failure between the lowering control valve and cylinder, the fuse limits the lowering speed of the cylinder.

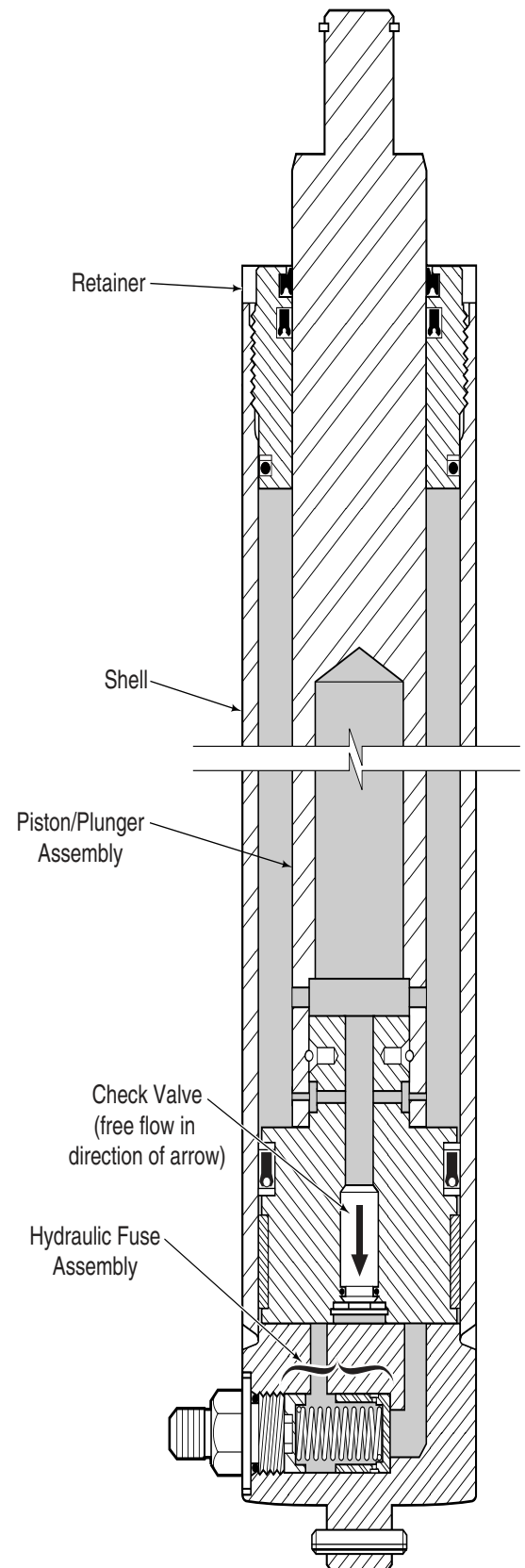

Figure 22. Free Lift Cylinder

Section 5 Service

5.2-4 Cylinder Operation

Cylinders Raising

1. When the truck hoist control valve is actuated, oil enters the lowering control valve through the inlet port and flows unrestricted through the lowering control cartridge.
2. Oil flows to the cylinder inlet ports. Due to the larger bore diameter of the free lift cylinder compared to both main lift cylinders, the free lift cylinder will raise completely before the main lift cylinders raise.
3. Oil flows through the free lift cylinder hydraulic fuse/cushion valve to the bottom of the piston. Lifting force is created against the bottom of the piston causing the plunger to raise. Oil in the area between the plunger and shell is allowed to escape through the check valve in the piston as the plunger raises to the end of its stroke.
4. **2000 PSI Piston Type Main Lift-Cylinders-** Oil flows through the hydraulic fuse/cushion valve to the bottom of the piston. Lifting force is created against the bottom of the piston causing the plunger to raise. Oil in the area between the plunger and shell is allowed to escape through the check valve in the piston as the plunger raises.
2600 PSI Displacement Type Main Lift Cylinders- Oil flows through the hydraulic fuse/cushion valve to the piston. The piston is internally ported to allow oil flow to the area between the plunger and shell. Lifting force is created that acts on the diameter of the plunger causing the plunger to raise.
5. When oil flow from the truck hoist control valve is discontinued, the cylinders are held in position by the closed center spool of the truck valve.

Cylinders Lowering

1. When the truck hoist control valve is actuated, the main lift then free lift cylinder plungers lower, forcing oil out through the hydraulic fuse/cushion valves.
NOTE: The restriction setting of each hydraulic fuse is lower (allows more oil flow) than the setting of the lowering control valve. The hydraulic fuses restrict flow only in the instance of a lowering control valve or hose failure.
2. Oil flows to the lowering control valve where it is restricted at a controlled speed determined by the load being handled.
3. As the main lift cylinder pistons lower over the spear in the bottom of the shell, a high pressure area is developed between the piston and shell which engages the cushion valve to restrict flow. This slows the piston/plunger just prior to bottoming providing a smooth transition to the free lift cylinder lowering.

Triple Mast (MT) Hydraulic Schematic

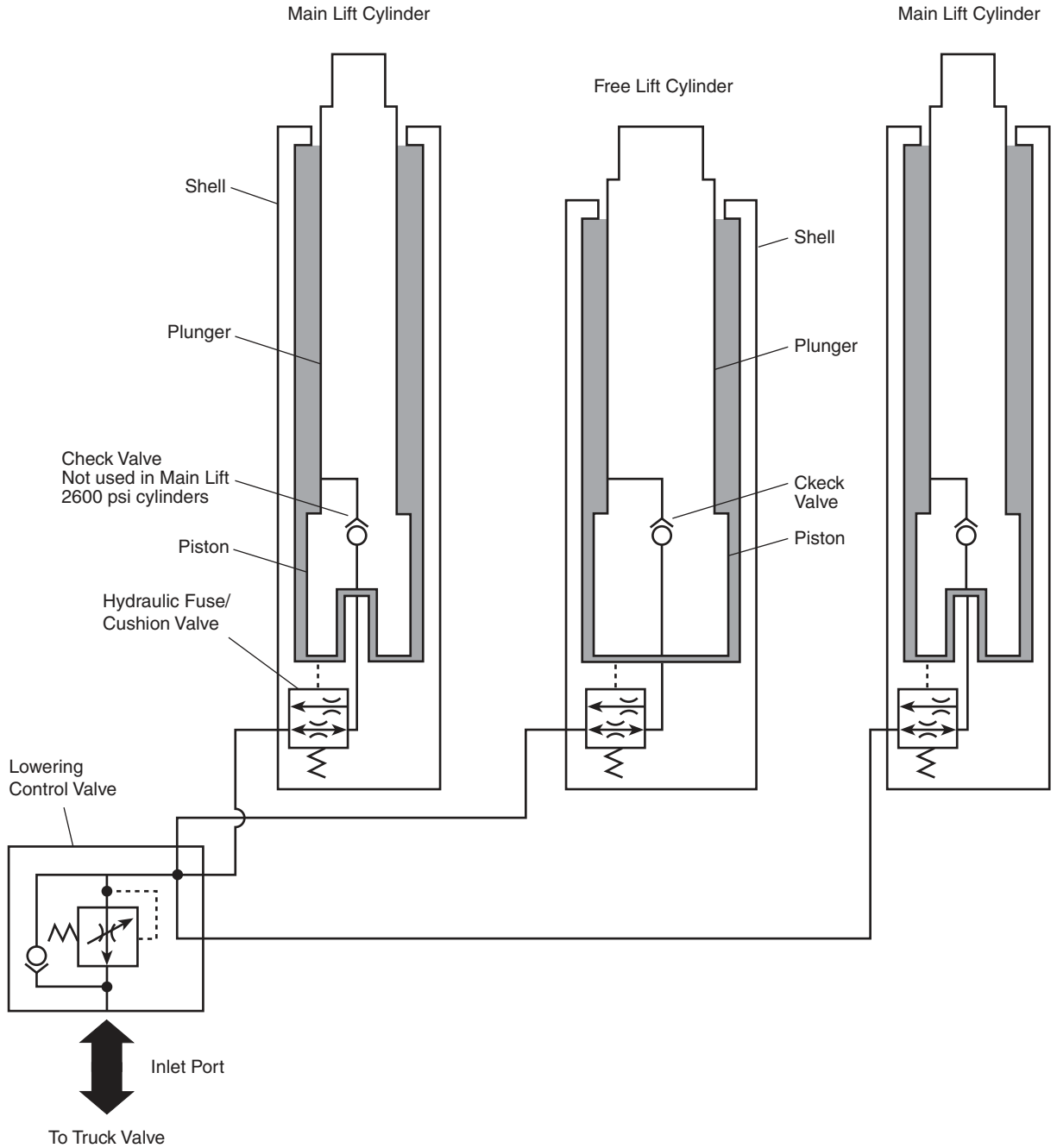

Figure 23. Cylinder Operation

Section 5 Service

5.2-5 Main Lift Cylinder Removal- Mast on Floor

1. **Remove** the mast from the truck as described in Section 5.1
2. Lay the mast down on wooden blocks as shown. Block under the outer upright so the inner upright will be free to move. The carriage must be positioned between the blocks and free to move.
3. Disconnect the cylinder supply hoses from the cylinder inlet ports. Remove the special long fittings from the cylinder ports and install plug fittings. **NOTE:** Each fitting holds a compressed spring in place.
4. Remove the snap rings fastening the cylinder rods to the intermediate upright.
5. Pull the inner and intermediate upright outward 2 ft. (60 cm).
6. Lift the cylinder from the base mount and angle inward to remove through the gap at the top of the uprights.
7. Note the number of shims (if equipped) on each cylinder rod.
8. For reassembly, reverse the above procedures except as follows:



WARNING: Main lift cylinders must be bled to remove trapped air prior to returning the mast to operation. Refer to Section 5.2-11.

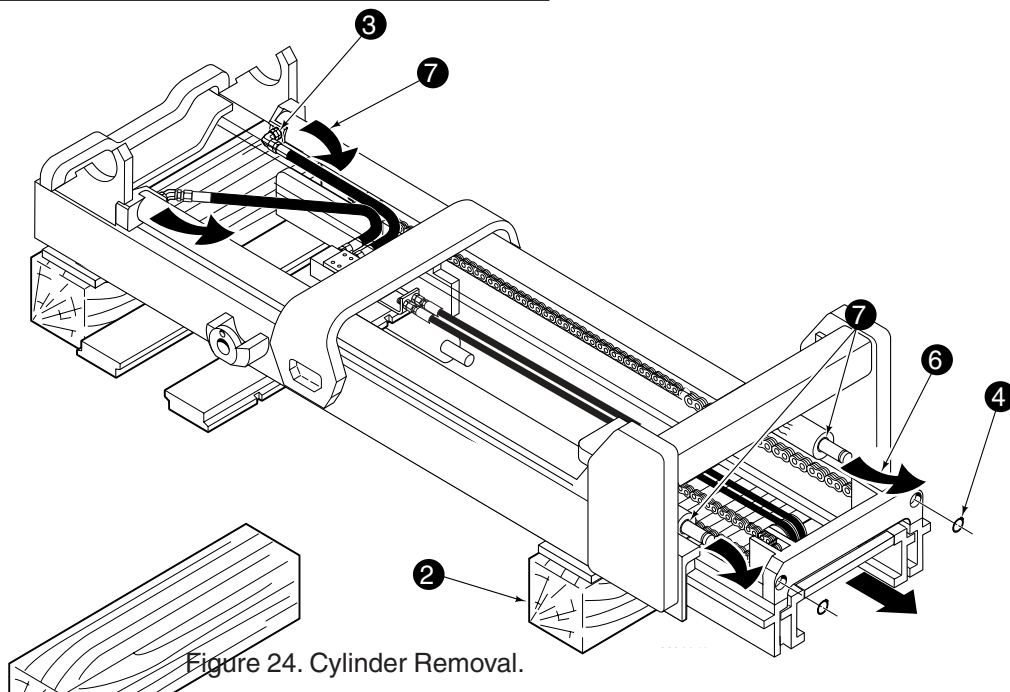

Figure 24. Cylinder Removal.

5.2-6

Free Lift Cylinder Removal- Mast on Floor

1. Remove the mast from the truck as described in Section 5.1.
2. Lay the mast down as shown.
3. Roll the carriage toward the center of the cylinder to slacken the chains and internal reeving hoses (if equipped).
4. Disconnect the hose from the cylinder 45° fitting. Cap the fitting and plug the hose.
5. Remove the chain guards from the crosshead. For reassembly, tighten the capscrews to a torque of 48-52 ft.-lbs. (65-70 Nm).
6. Remove the snap ring fastening the crosshead to the cylinder rod.
7. Pull the crosshead with chains and hoses (if equipped) off the cylinder rod.
8. Remove the cylinder strap.
9. Remove the cylinder from the mast.
10. For reassembly, reverse the above procedures.

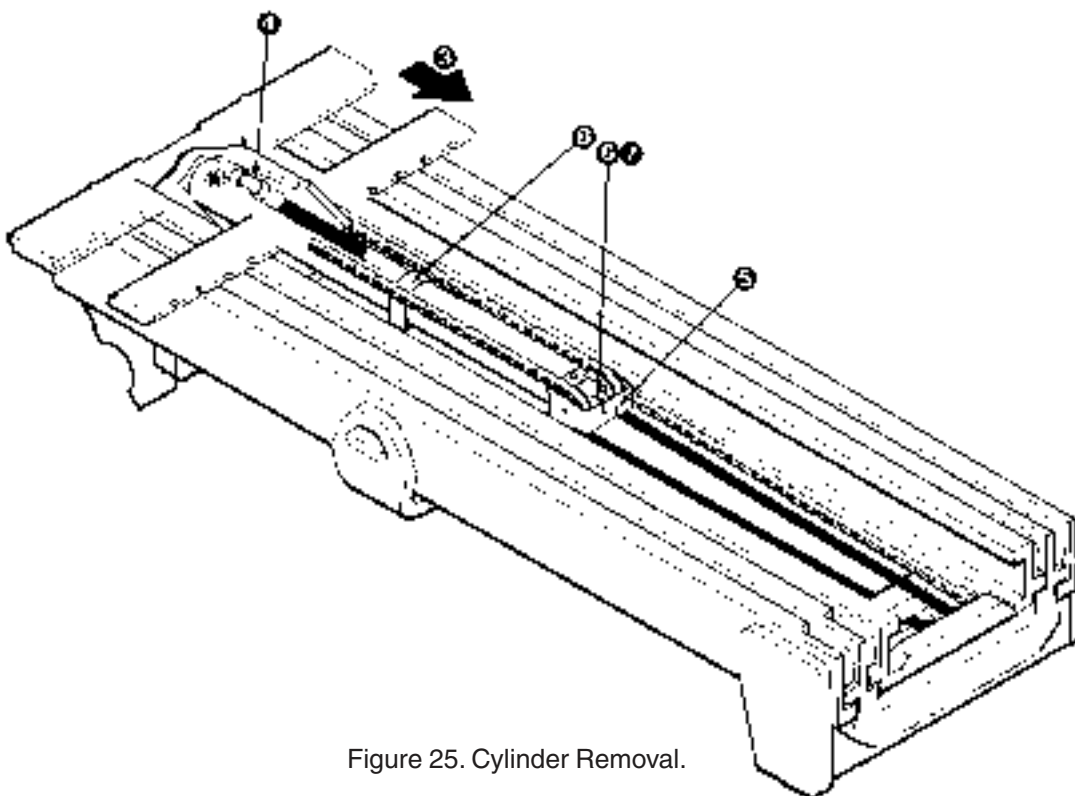

Figure 25. Cylinder Removal.

Section 5 Service

5.2-7 Free Lift Cylinder Removal- Mast on Truck

1. Completely lower the carriage. Remove forks or attachment if equipped. Make sure the free lift cylinder is completely retracted. Attach an overhead hoist to the top carriage bar.



WARNING: The carriage must be supported by a block while removing the cylinder to avoid possible injury.

2. Raise the carriage to the center of the cylinder to slacken the chains and internal reeving hoses (if equipped). Block the carriage in place using a 4 X 4 X 24 in. (10 X 10 X 60 cm) wood block between the lower carriage bar and the floor.
3. Remove the cylinder strap.
4. Remove the chain guards from the crosshead. For reassembly, tighten the capscrews to a torque of 48-52 ft.-lbs. (65-70 Nm).
5. Remove the snap ring fastening the crosshead to the cylinder rod.
6. Pull the crosshead with chains and hoses (if equipped) off the cylinder rod and lay over upper carriage bar.
7. Pry the cylinder up out of the support casting to gain access to the cylinder hose fitting. Remove the hose from the 45° fitting. Cap the fitting and plug the hose.
8. Remove the cylinder from the mast from the top.
9. For reassembly, reverse the above procedures.

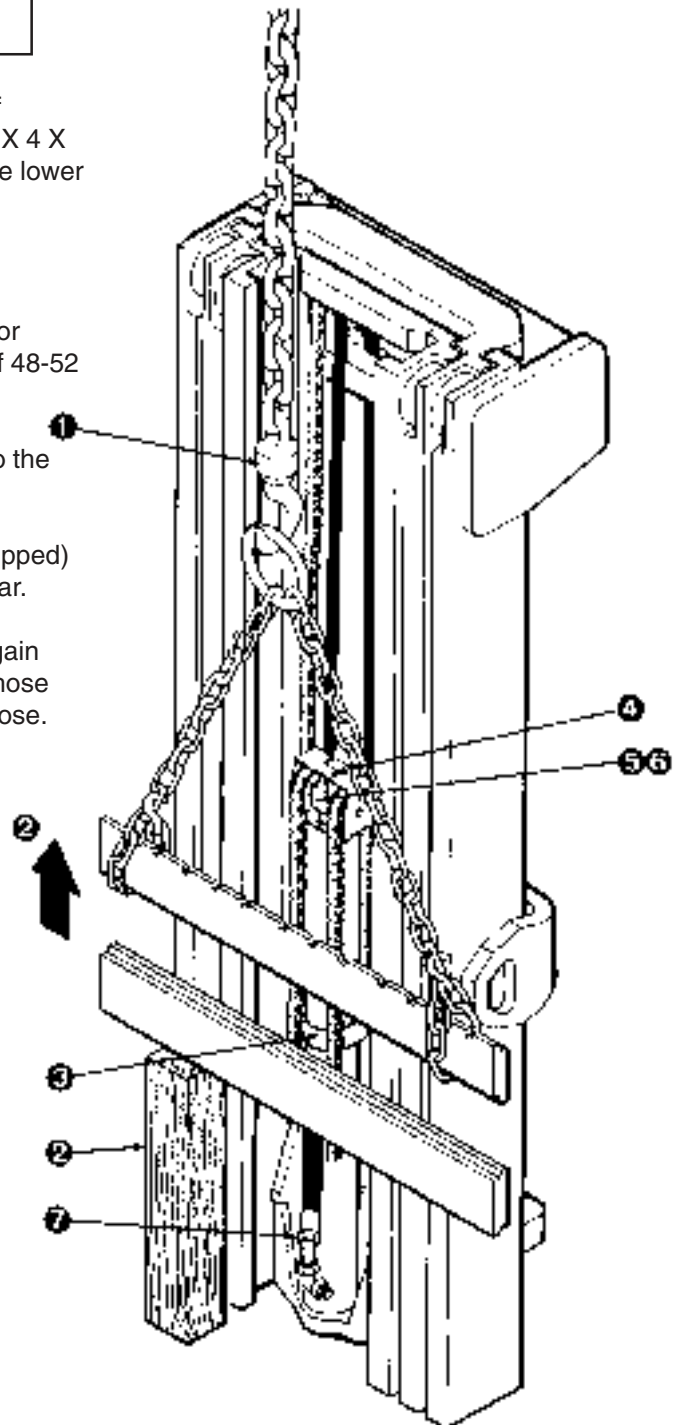

Figure 26. Cylinder Removal.

Section 5 Service

5.2-8 Main Lift Cylinder Service

1. Remove the cylinder from the mast as described in Section 5.2-5.
2. Use a claw type spanner wrench to remove the retainer. See Figure 27.
3. **Remove** the plunger/piston assembly from the shell.
4. Remove the Hydraulic Fuse/Lowering Cushion components.
5. Inspect all components for nicks or burrs. Minor nicks or burrs can be removed with 400 grit emery cloth.
NOTE: Minor nicks are those that will not bypass oil when under pressure. If they cannot be removed with emery cloth, replace the part. If the piston requires replacing, refer to Section 5.2-10.
6. Replace the retainer and piston seals, back-up rings O-rings and bearing. Lubricate the new seals with petroleum jelly prior to installation. **Note the correct seal directions.** The cylinder will not operate correctly if the seals are installed backwards.
7. **2000 PSI CYLINDERS-** When replacing the piston check valve O-ring, make sure the check valve is reinstalled with the arrow pointed in the correct direction.
8. Install the plunger retainer on the plunger. Install the plunger/piston assembly into the cylinder shell. Tighten the retainer to the torque value listed below using the claw spanner wrench and a strap wrench.

30D/35D/40D- 95-125 ft.-lbs. (129-169 Nm)
50D/55D/60D- 225-250 ft.-lbs. (305-340 Nm)

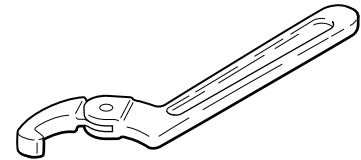

Figure 27. Claw Type Spanner Wrench..

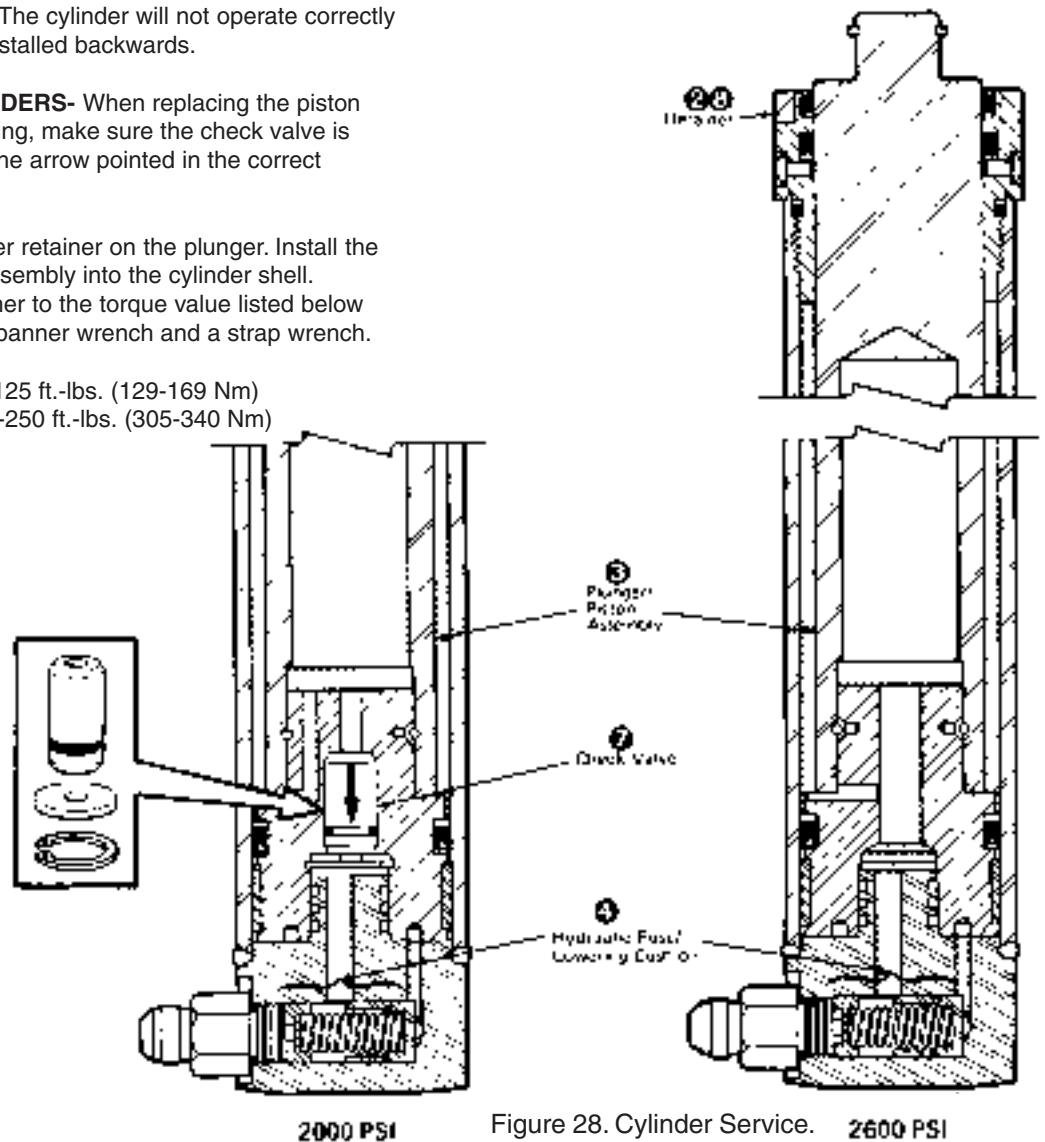

Figure 28. Cylinder Service. 2600 PSI

Section 5 Service

5.2-9 Free Lift Cylinder Service

1. Remove the cylinder from the mast as described in Section 5.2-6 or 5.2-7.
2. Use a claw type spanner wrench to remove the retainer. See Figure 29.
3. Remove the plunger/piston assembly from the shell.
4. Remove the Hydraulic Fuse/Lowering Cushion components.
5. Inspect all components for nicks or burrs. Minor nicks or burrs can be removed with 400 grit emery cloth.
NOTE: Minor nicks are those that will not bypass oil when under pressure. If they cannot be removed with emery cloth, replace the part. If the piston requires replacing, refer to Section 5.2-10.
6. Replace the retainer and piston seals, back-up rings, O-rings and bearing. Lubricate the new seals with petroleum jelly prior to installation. **Note the correct seal directions.** The cylinder will not operate correctly if the seals are installed backwards.
7. When replacing the piston check valve O-ring, make sure the check valve is reinstalled with the arrow pointed in the correct direction.
8. Install the plunger retainer on the plunger. Install the plunger/piston assembly into the cylinder shell. Pour 1/2 cup (120 ml) hydraulic oil into the cylinder cavity between the shell and rod. Tighten the retainer to a torque of 275-300 ft.-lbs. (375-405 Nm) using the claw spanner wrench and a strap wrench.

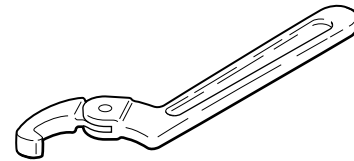

Figure 29. Claw Type Spanner Wrench..

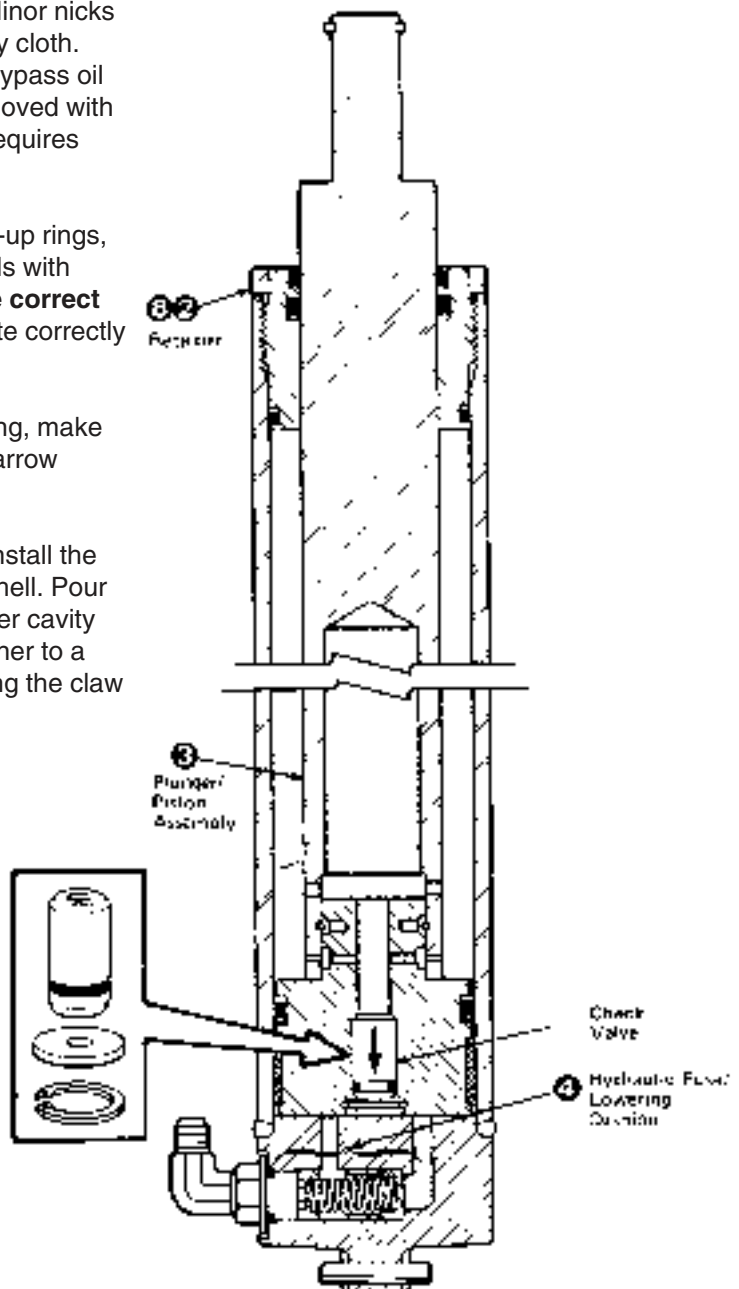

Figure 30. Cylinder Service.

Section 5 Service

5.2-10 Piston Removal

1. Remove the plunger/piston assembly from the cylinder shell as described in Section 5.2-8 or 5.2-9.
2. **Use** a strap wrench and 400 grit emery cloth to secure the plunger while turning the piston with a pin type spanner wrench
3. Turn the piston until the snap wire end is visible through the hole. Use a screwdriver to start the wire end out the hole. Turn the piston to feed the wire out.
4. Pull the piston from the plunger.
5. For reassembly, reverse the above procedures except as follows:
*Install a new snap wire when installing the piston.

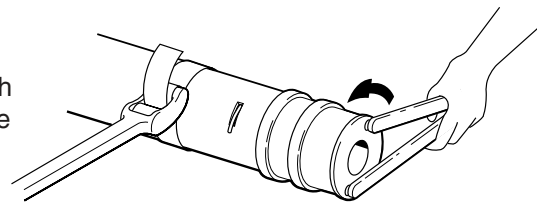

Figure 31. Piston Removal.

5.2-11 Cylinder Bleeding

WARNING: The cylinders must be bled to remove air. Air in the cylinders will compress on the first extension which could rupture the cylinders causing serious bodily injury and property damage.

After repair, the cylinders may have air trapped in them that must be removed. To bleed air do the following:

1. **Without a load** extend the free lift cylinder and continue to extend the main lift cylinders to 90% of full stroke. Retract all cylinders completely. Repeat **three** times.
2. Extend the cylinders **without a load** at 50% full engine speed then build to full system pressure at the end of the main lift cylinder stroke. Electric trucks - limit the control valve movement to achieve 50% speed. Retract all cylinders. Repeat **four** times.
3. Cycle the mast with a half load (50% mast rated capacity) through full cylinder extension several times. The cylinders should extend smoothly. Repeat the steps if cylinder extension is not smooth.

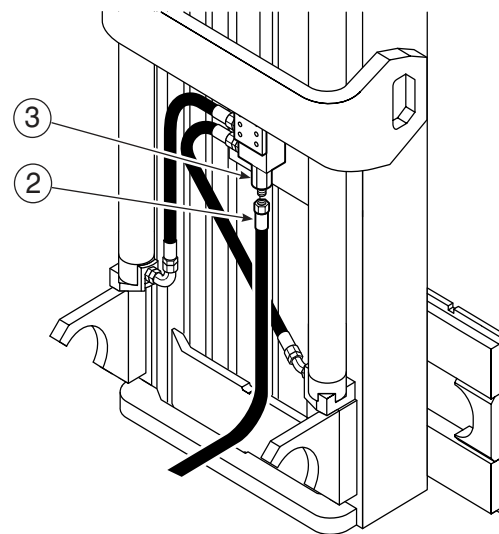

Figure 32. Valve Cartridge Service.

5.3 Valve

5.3-1 Valve Cartridge Service

1. Completely lower the mast.
2. Remove the truck supply hose from the valve cartridge. See Figure 32. Plug the hose.
3. Remove the valve cartridge from the valve. Note the stamped part no. on the Cartridge for ordering a replacement.

WARNING: Replacing the valve cartridge with a different part no. cartridge may cause the mast to malfunction.

4. For reassembly, reverse the above procedures.

Section 5 Service

5.4 Carriage

5.4-1 Description

The carriage shown below is the structure that hook-type forks or attachments are attached. The carriage travels within the rails of the mast inner upright on four (or six optional) shim adjustable rollers. The rollers are held in the uprights*. All load rollers are interchangeable. There are four side thrust rollers to transfer carriage side loading to the inner rails. These rollers are eccentrically adjustable. A pair of chain anchors are used to connect the carriage chains to the carriage.

**Except on 6 roller carriages where the top roller extends past the top of the mast inner upright at full extension and are held in place by a retainer plate.*

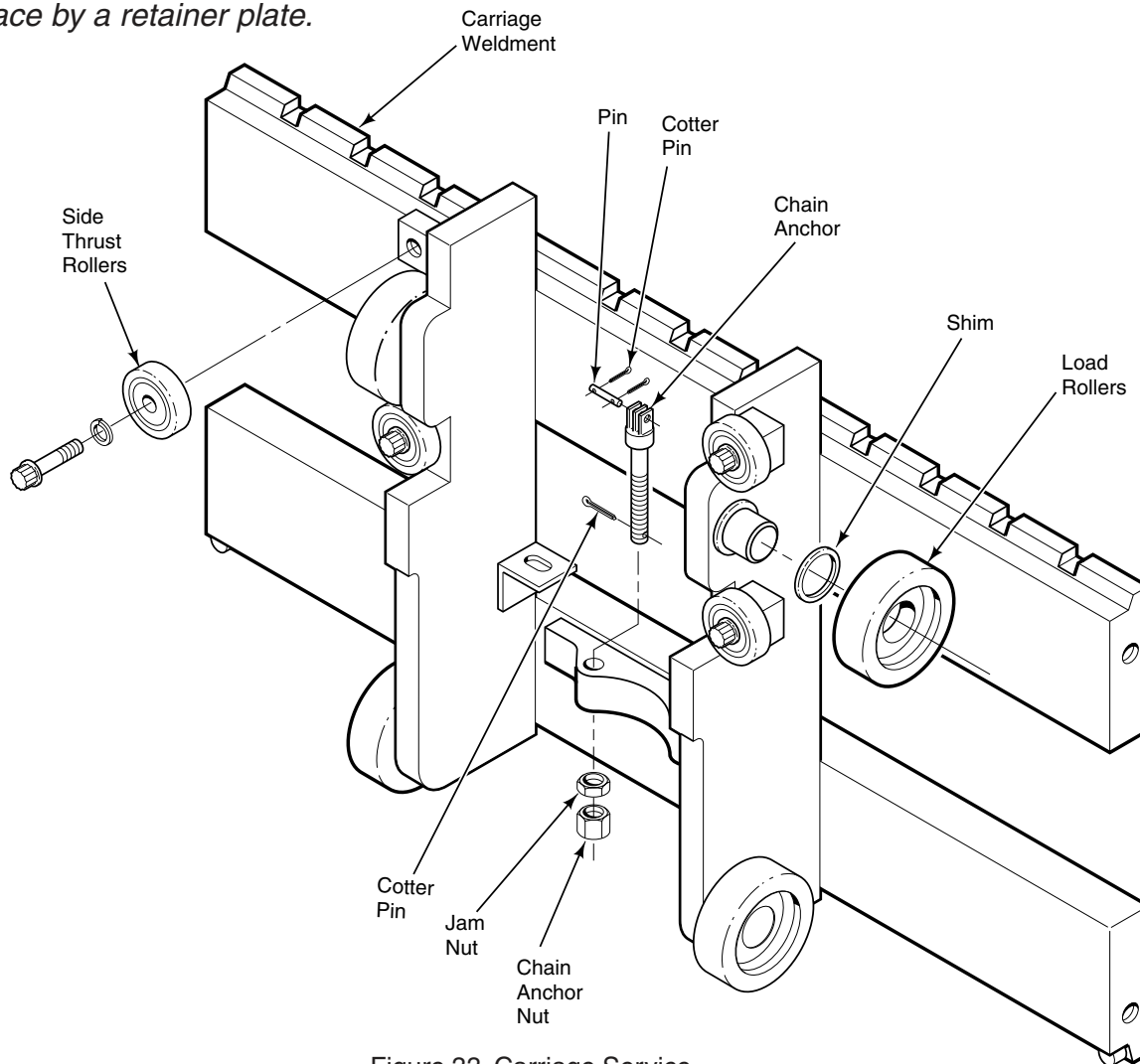

Figure 33. Carriage Service.

IMPORTANT: The chain anchor nuts must be installed as shown for correct operation.

Section 5 Service

5.4-2 Carriage Removal-Mast on Truck

1. Raise the mast high enough to place a 20 in. (50 cm) long, 4X4 in. (10 X 10cm) wood block between the intermediate lower crossmember and the ground. Lower the carriage to be even with the bottom of the inner upright
2. Attach an overhead hoist to the carriage. Raise the carriage to slacken the carriage chains.
3. Remove the chain anchor nuts. Note the location of the double nuts for reassembly.
4. Disconnect the internal reeving hoses from the carriage fittings (if equipped). Plug the hose ends.
5. Using the overhead hoist, lower the carriage to the bottom of the mast to remove.
6. Note the number of shims behind each load roller for reassembly.
7. For reassembly, reverse the above procedures except as follows:

*inspect the carriage as described in Section 5.4-4.

*Lubricate the inner upright rails with chassis lube or Kendall SR-12X.
See Figure 34.

*Assemble shims and load rollers on the stub shafts. The shims should be installed to provide a total side to side clearance no looser than 1/16 in. (1.5 cm) at the tightest point throughout the travel of the carriage. Use an equal amount of shims side to side.

*Adjust the carriage side thrust rollers for unrestricted clearance along the travel of the carriage. The rollers have eccentric mount bases. Turn the base of the roller toward the upright rail to decrease clearance. See Figure 28. Tighten the capscrews to a torque of 70-80 ft.-lbs. (95-110 Nm).

*Check and adjust the free lift chains as described in Section 5.6-4 and 5.6-6.

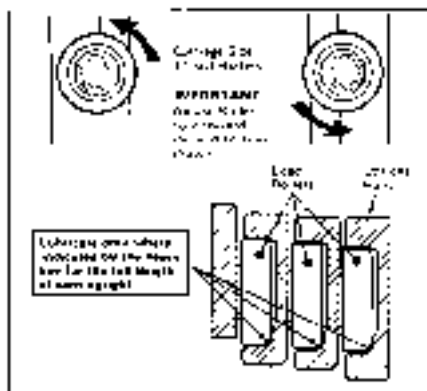

Figure 34. Rail Lubrication and Carriage Side Thrust Rollers.

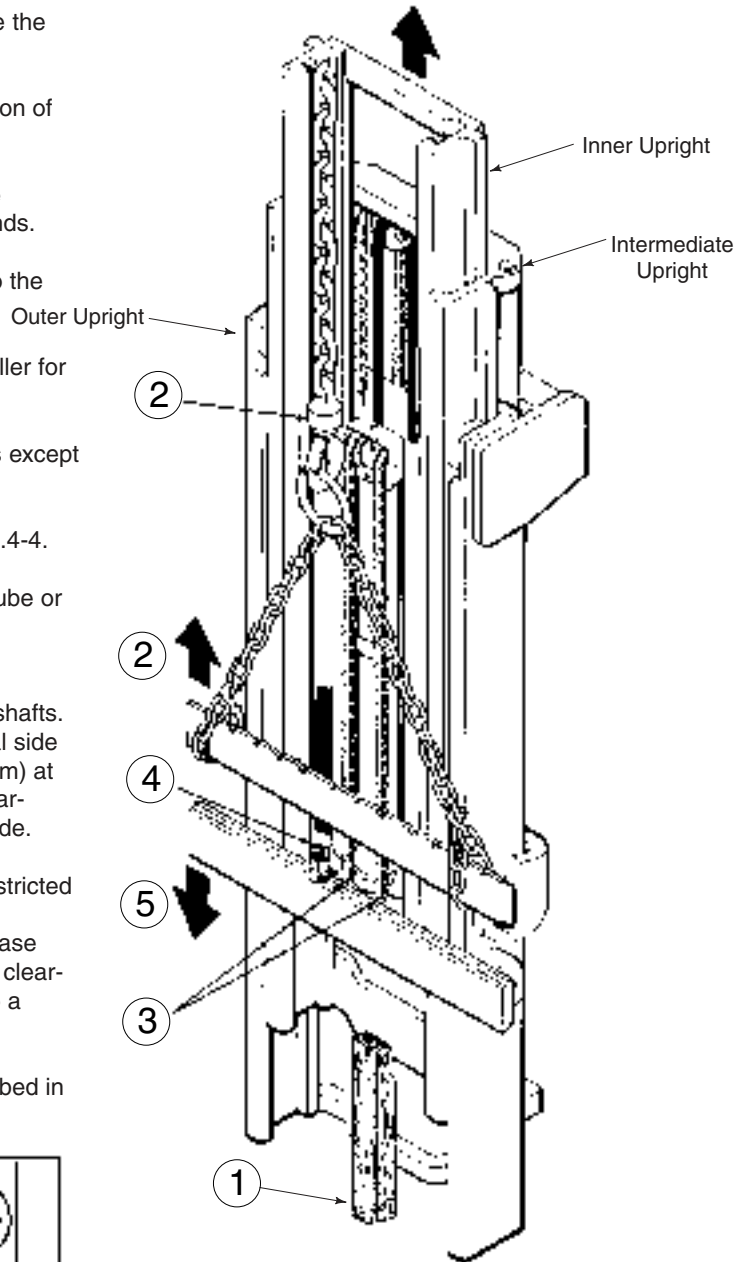

Figure 35. Carriage Removal.

Section 5 Service

5.4-3

Carriage Removal- Mast on Floor

1. Remove mast from truck as described in Section 5.1.
2. Remove chain anchor nuts. Note location of double nuts for reassembly. Remove the chain anchors.
3. Disconnect the internal reeving hoses for the carriage fittings (if equipped). Plug the hose ends.
4. Roll the carriage to the bottom of the mast.
5. Attach an overhead hoist to the carriage for bars. Remove the carriage through the bottom of the mast.
6. Note the number of shims located behind each load roller for reassembly.

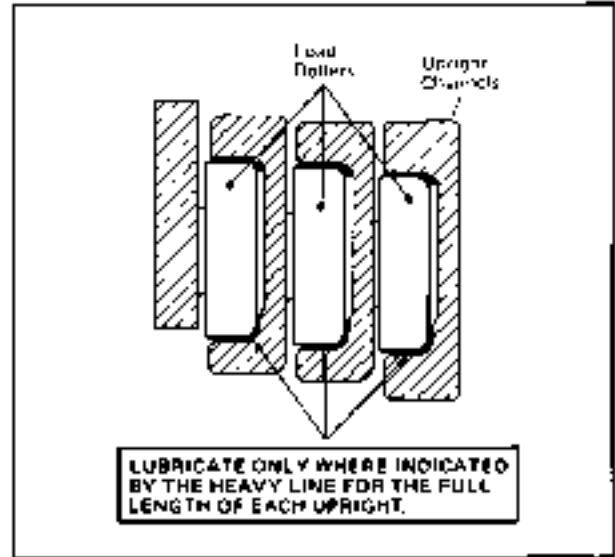

Figure 36. Rail Lubrication.

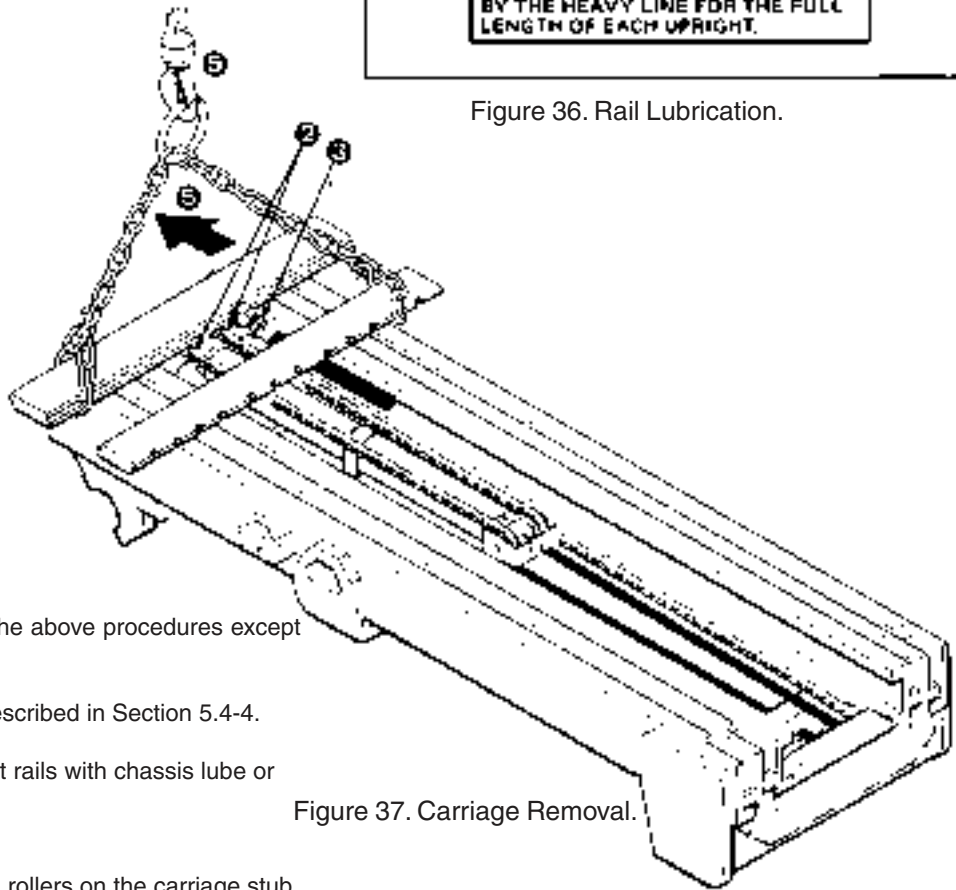

Figure 37. Carriage Removal.

7. For Reassembly, reverse the above procedures except as follows:

*inspect the carriage as described in Section 5.4-4.

*Lubricate the inner upright rails with chassis lube or Kendall SR-12X . See Figure 38.

*Assemble shims and load rollers on the carriage stub shafts. The shims should be installed to provide a total side to side clearance no looser than 1/16 in. (1.5 mm) at the tightest point throughout the travel of the carriage. Use an equal amount of shims side to side.

*Adjust the carriage side thrust rollers for unrestricted clearance along the travel of the carriage. The rollers have eccentric mount bases. Turn base of rollers toward the upright rail to decrease clearance. Tighten to a torque of 70-80 ft.-lbs. (96-110 Nm).

*Check and adjust the free lift chains as described in Section 5.6-4 and 5.6-6.

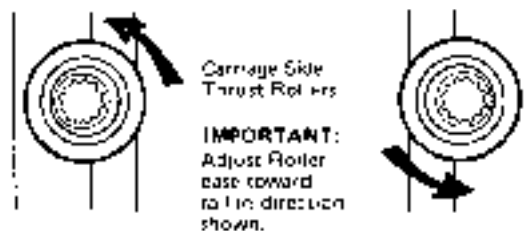

Figure 38. Carriage Side Thrust Rollers.

Section 5 Service

5.4-4 Carriage Inspection

1. Inspect the rollers for excessive wear or damage. Rollers with visible flat spots or cracks should be replaced.
2. Inspect the roller bearings by turning the rollers on their shafts. Rollers with roughness or noticeable restrictions to turning should be replaced.
3. Inspect all welds between the carriage side plates and the carriage fork bars. If any welds are cracked, replace the carriage.
4. Inspect the roller stub shafts. If they are damaged or if there are cracks at the base of the stub shafts, the carriage must be replaced or repaired. Contact Lift Tek for repair procedures.

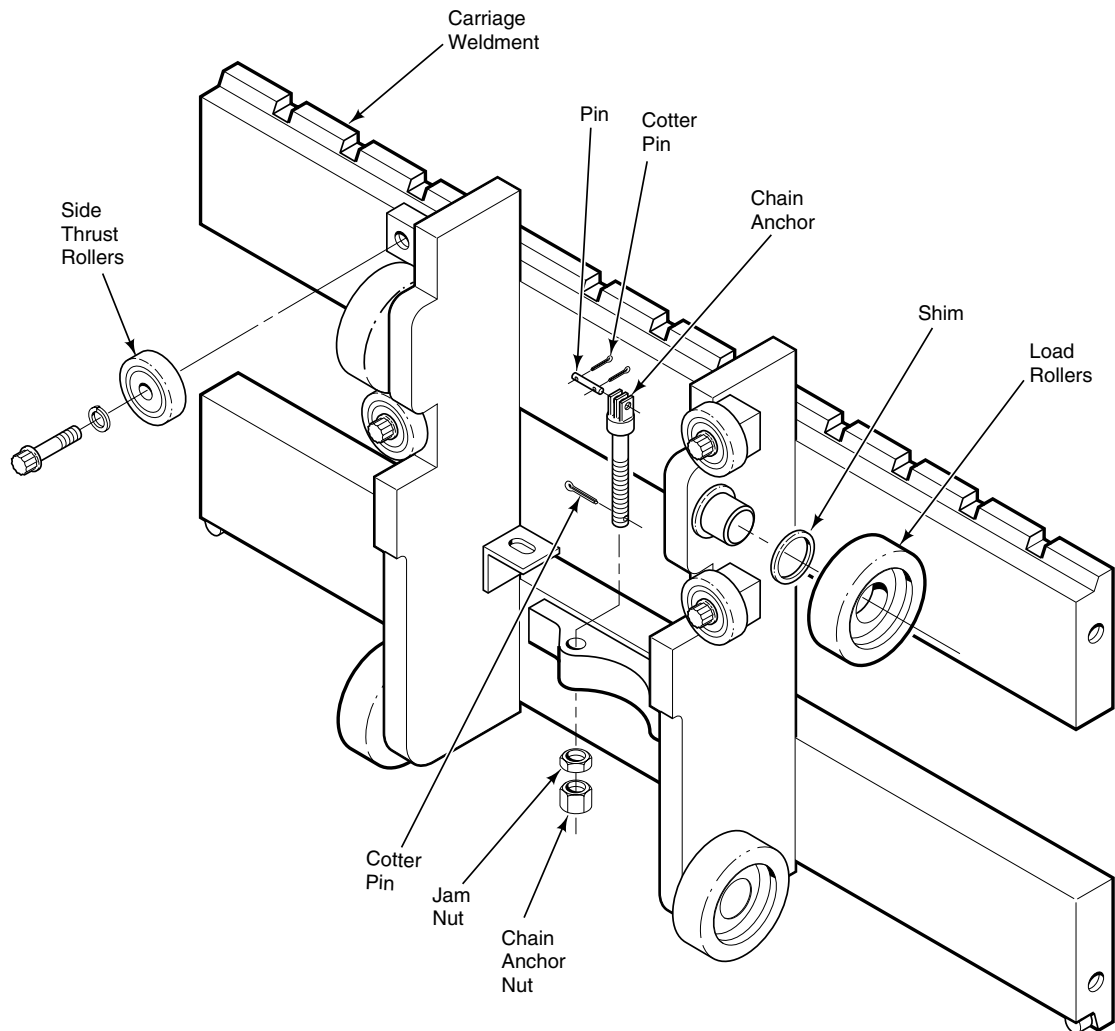

Figure 39. Carriage .

IMPORTANT: The chain anchor nuts must be installed as shown for correct operation.

Section 5 Service

5.5 Mast Uprights

5.5-1 Upright Description

Outer Upright Assembly

The outer upright assembly is mounted to the truck. A pair of shim adjustable load rollers are attached to stub shafts located near the top of the upright. A pair of adjustable hoist chain anchors are located on the top crossmember.

Intermediate Upright Assembly

The intermediate upright assembly telescopes within the outer upright assembly. A pair of shim adjustable load rollers are attached to stub shafts located at the top and bottom of the upright. A pair of chain sheaves are located near the top of the upright to provide a rolling surface for the main lift chains.

Inner Upright Assembly

The inner upright assembly telescopes within the intermediate upright assembly. A pair of shim adjustable load rollers are attached to stub shafts located at the bottom of the upright. The free lift chain anchors are attached to the center crossmember. The free lift cylinder rests on a cradle which is integral with the lower crossmember.

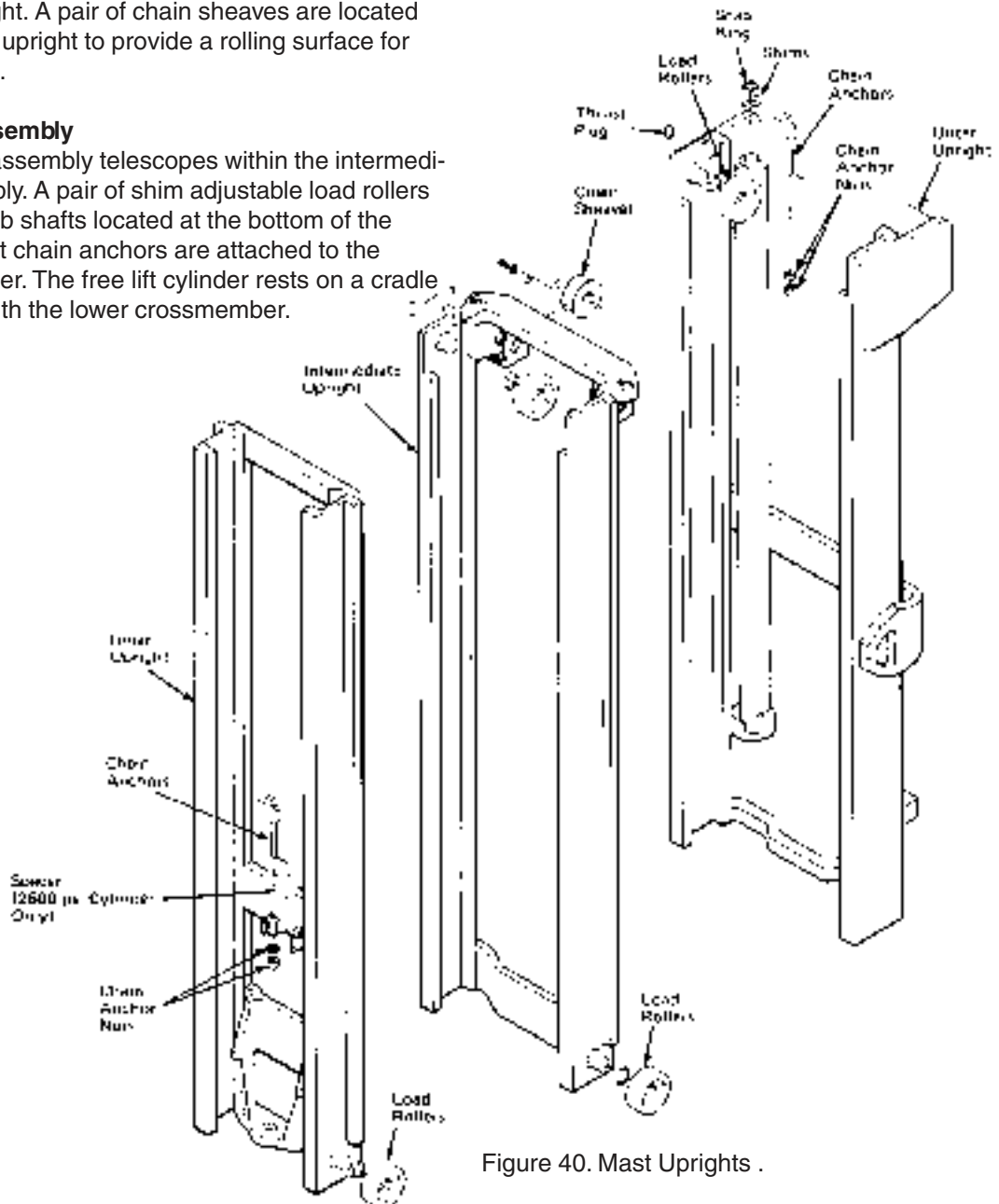

Figure 40. Mast Uprights .

Section 5 Service

5.5-2 Upright Operation

Fully Lowered

The main Lift chains are anchored to the outer upright top crossmember then travel over the intermediate upright chain sheaves and attach to the inner upright anchors.

The free lift chains are anchored to the inner upright center crossmember then travel over the free lift cylinder chain sheaves and attach to the carriage chain anchors.

Free Lift

Actuating the truck hoist valve causes the free lift cylinder to raise which draws the carriage to the top of the inner upright.

Full Extension

When the free Lift cylinder reaches the end of its stroke the main lift cylinders begin to rise. The extension of the cylinders causes the intermediate and inner uprights to raise.

Lowering

The main lift cylinders lower at the same time. Once the main lift cylinder have nottomed out, the free lift cylinder begins to lower resulting in a smooth lowering of the carriage.

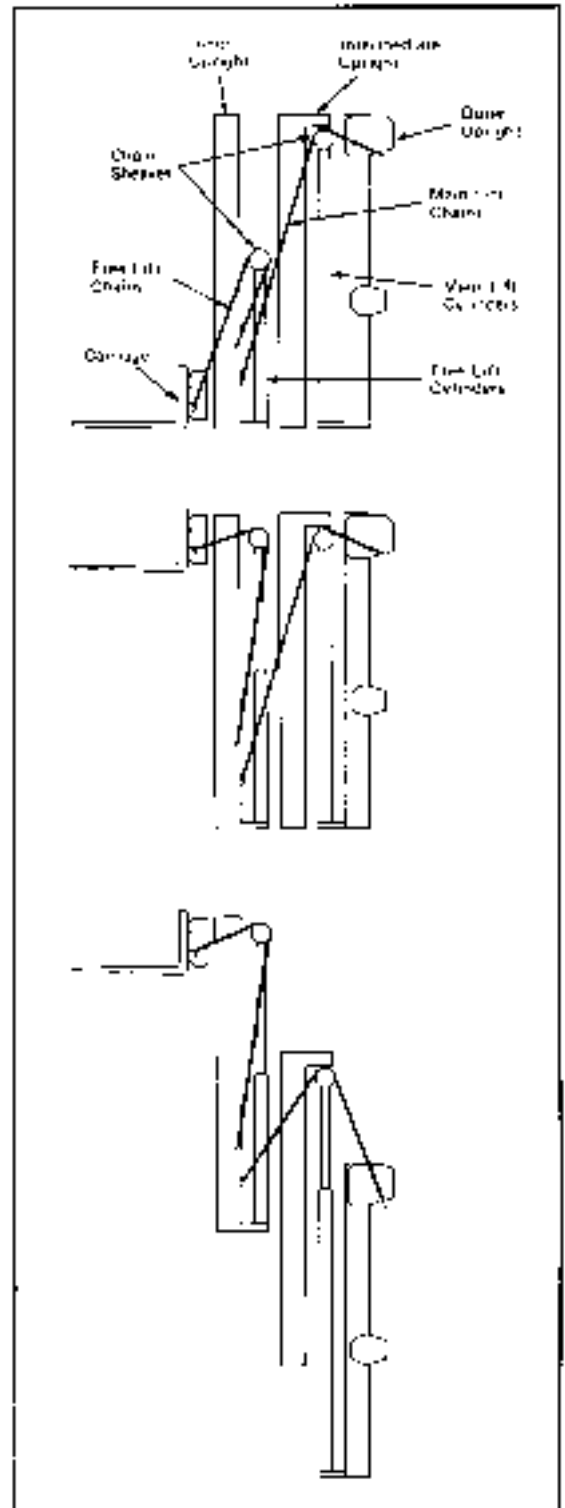
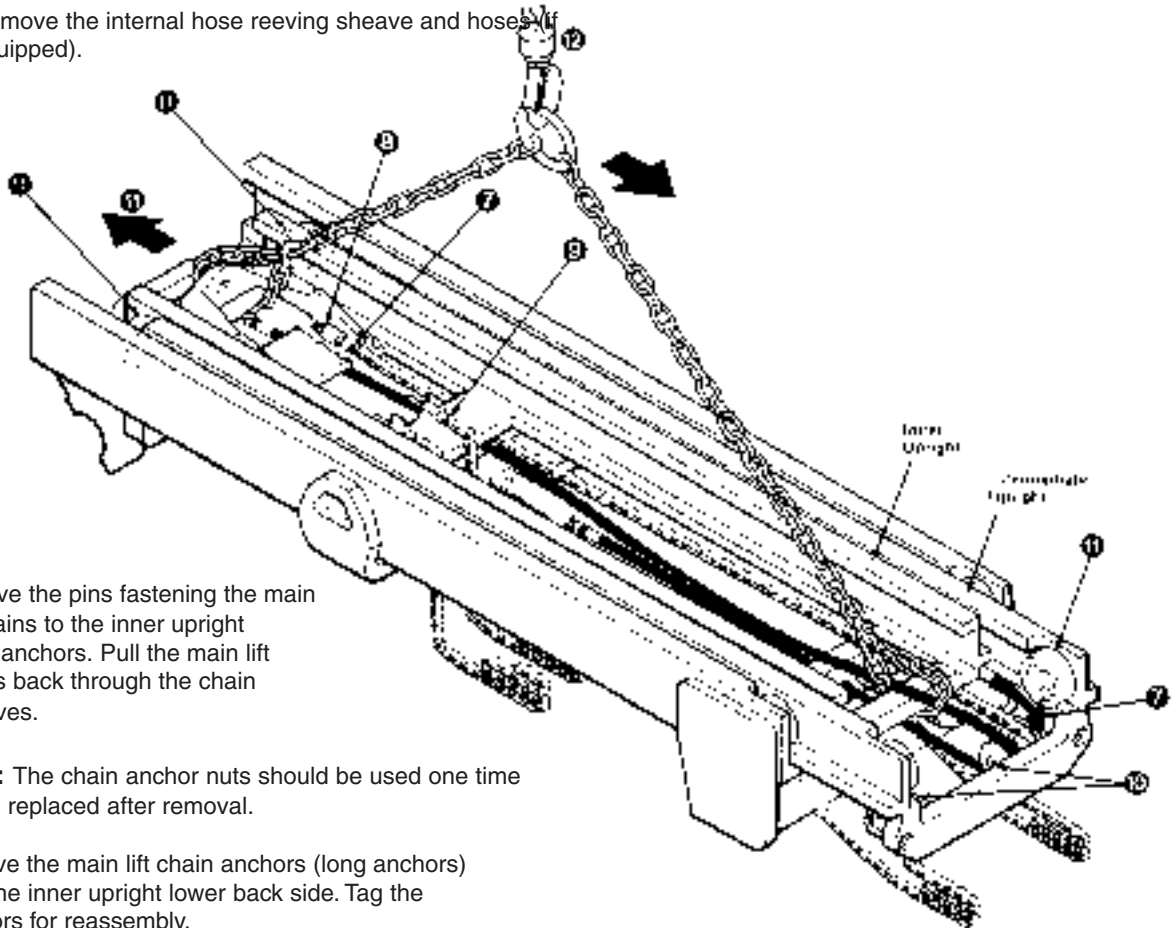

Figure 41. Upright Operation .

Section 5 Service

5.5-3 Upright Disassembly

1. Remove the mast assembly from the truck as described in Section 5.1.
2. Remove the main lift cylinders from the mast as described in Section 5.2-5.
3. Turn the mast over.
4. Remove the free lift cylinder from the mast as described in Section 5.2-6.
5. Remove the carriage from the mast as described in Section 5.4-3.
6. Remove the internal hose reeving sheave and hoses (if equipped).



7. Remove the pins fastening the main lift chains to the inner upright chain anchors. Pull the main lift chains back through the chain sheaves.

CAUTION: The chain anchor nuts should be used one time only and be replaced after removal.

8. Remove the main lift chain anchors (long anchors) from the inner upright lower back side. Tag the anchors for reassembly.
9. Remove the pins fastening the free lift chains to the inner upright chain anchors.
10. Remove the free lift cylinder supply hose and sheave. Remove the main lift chain sheaves.
11. Roll the inner upright downward to expose the inner and intermediate upright load rollers. Remove the load rollers. Note the number of shims behind each load roller.
12. Attach an overhead hoist to the inner upright. Remove the inner upright through the top of the intermediate upright.

Figure 42. Upright Disassembly .

Section 5 Service

5.5-3 Upright Disassembly

(Continued)

CAUTION: The chain anchor nuts should be used one time only and be replaced after removal.

13. Remove the main lift chain anchors (long anchors) and chains from the outer upright crossmember. Tag the anchors for reassembly.
14. Roll the inner upright downward to expose the intermediate and outer upright load rollers. Remove the load rollers. Note the number of shims behind each load roller.
15. Attach an overhead hoist to the intermediate upright. Remove the intermediate upright through the top of the outer upright.

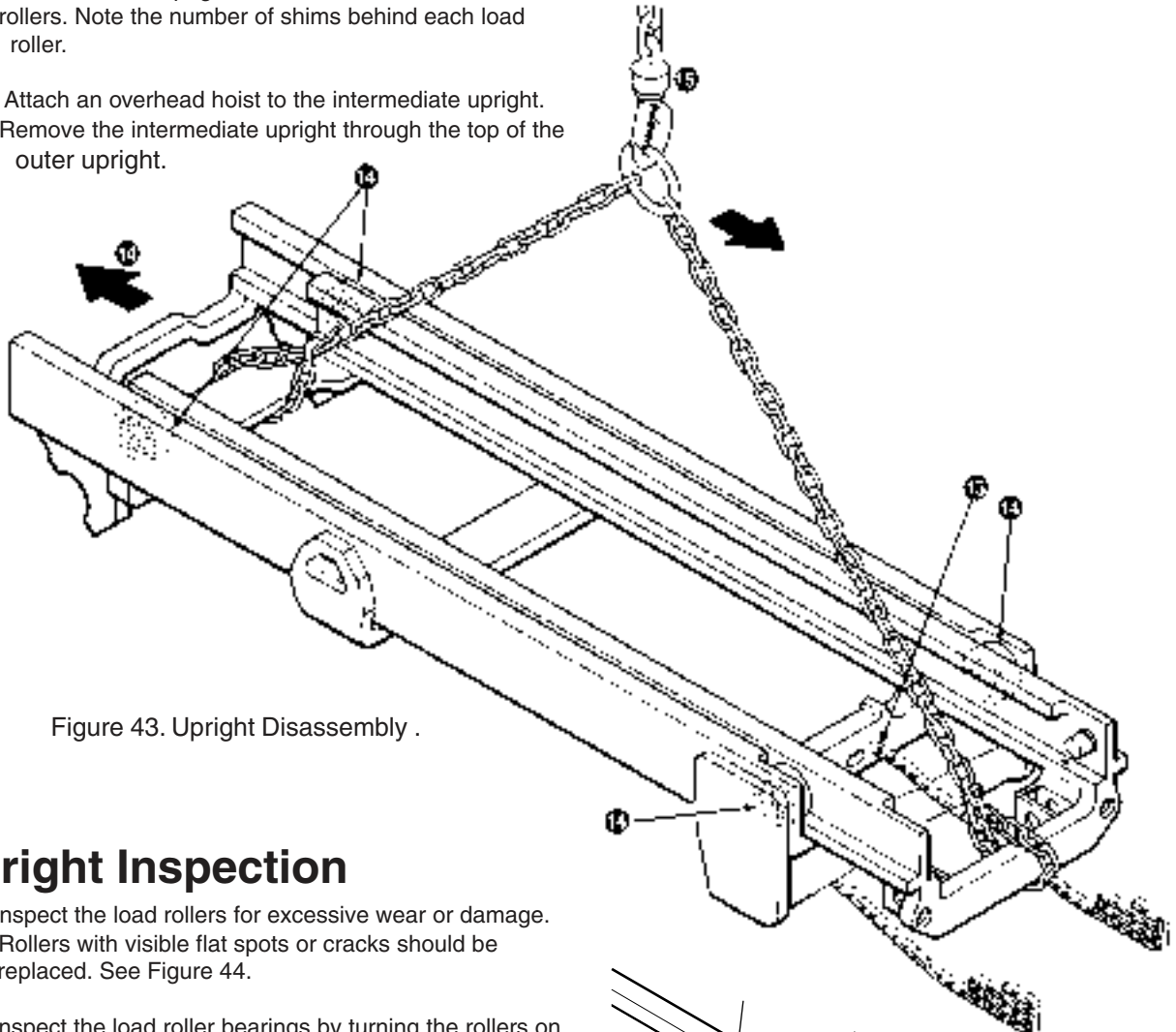

Figure 43. Upright Disassembly .

5.5-4 Upright Inspection

1. Inspect the load rollers for excessive wear or damage. Rollers with visible flat spots or cracks should be replaced. See Figure 44.
2. Inspect the load roller bearings by turning the rollers on their shafts. Rollers with roughness or noticeable restrictions to turning should be replaced.
3. Inspect the load roller stub shafts. If they are damaged or have cracks at the base, the upright mast must be replaced or repaired.
4. Inspect the outer and intermediate upright thrust plugs. If the wear surface is worn to less than 1/16 in. (1.5 mm), they should be replaced.
5. Inspect the hoist chains as described in Section 5.6-1.

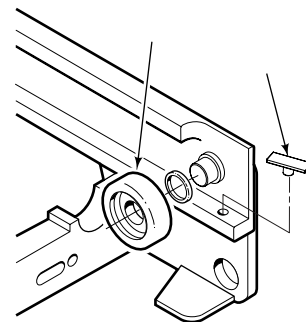

Figure 44. Upright Inspection .

Section 5 Service

5.5-5 Upright Reassembly

1. Lubricate the outer upright rails with chassis lube or Kendall SR-12X. See Figure 45.
2. Attach an overhead hoist to the intermediate upright. Install the intermediate upright through the top of the outer upright.
3. Install the thrust plugs to the uprights.
4. Assemble shims and load rollers to the outer upright and lower intermediate upright stub shafts. The shims should be installed to provide a total side to side clearance no looser than 1/16 in. (1.5 mm) at the tightest point throughout the travel in the upright. Use an equal amount of shims side to side. **NOTE:** Roll the upright past the thrust plugs before checking roller clearances.
5. Lubricate the intermediate upright rails with chassis lube or Kendall SR-12X. See Figure 40.

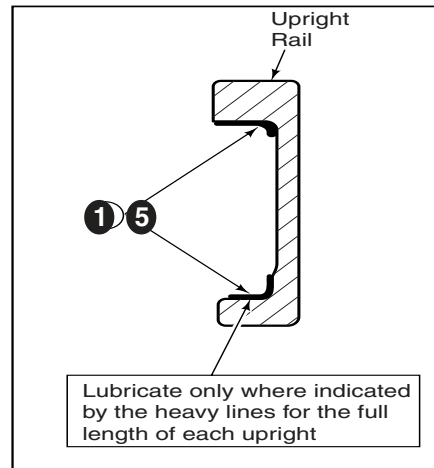

Figure 45. Rail Lubrication

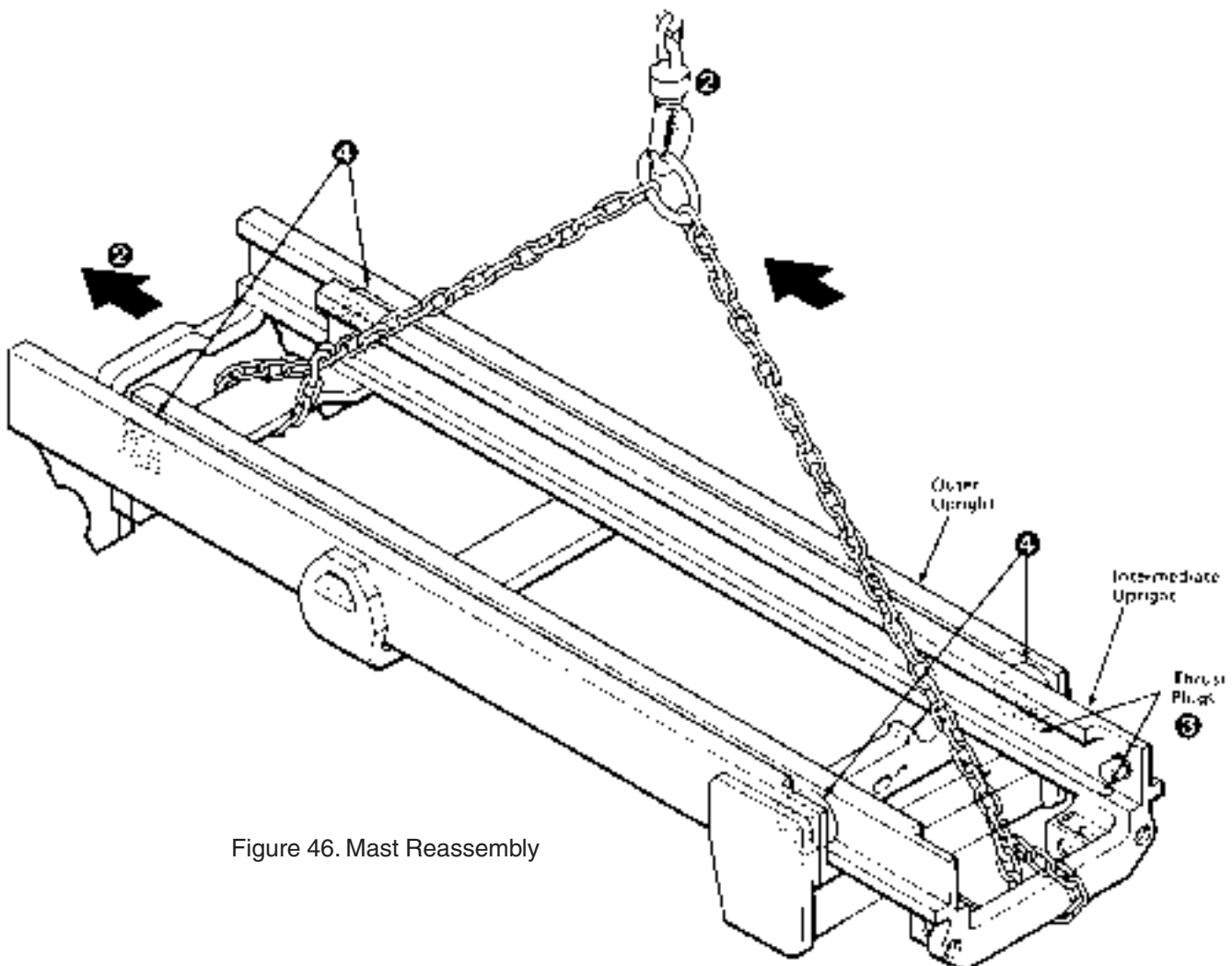

Figure 46. Mast Reassembly

Section 5 Service

5.5-5 Upright Reassembly (Continued)

5. Attach an overhead hoist to the inner upright. Install the inner upright through the top of the intermediate upright.
6. Assemble shims and load rollers to the intermediate upright top and inner upright lower stub shafts. The shims should be installed to provide a total side clearance no loosest than 1/16 in. (1.5 mm) at the tightest point throughout the travel in the upright. Use an equal amount of shims side to side. **NOTE:** Roll the upright past the thrust plugs before checking roller clearances.
7. Install the chain sheave and free lift hose sheave to the intermediate upright. Tighten the capscrew to a torque of 26-30 ft.-lbs. (35-40 Nm).
8. Install the main lift chain anchors (long anchors) and chains to the outer upright crossmember.

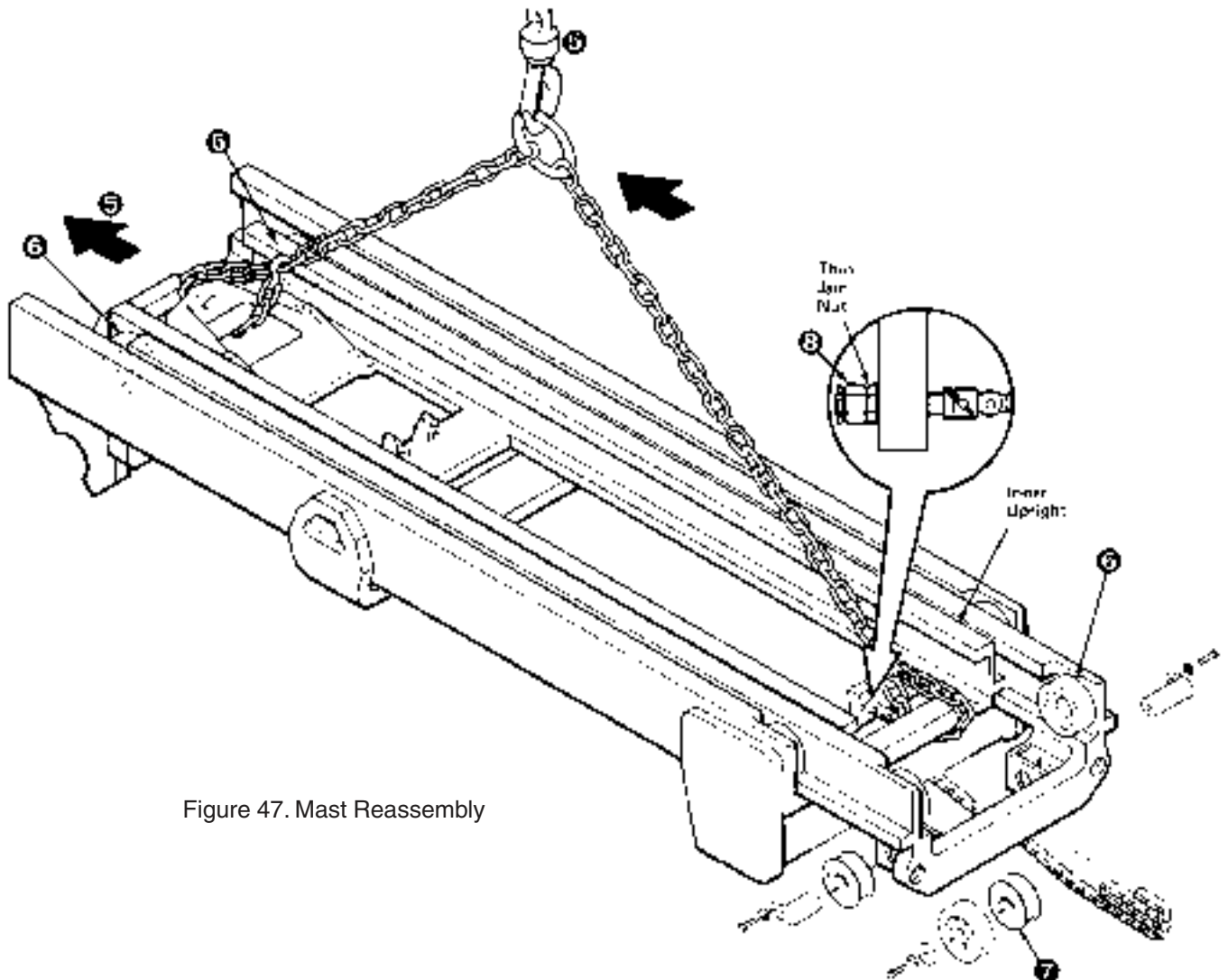

Figure 47. Mast Reassembly

Section 5 Service

5.5-5 Upright Reassembly

(Continued)

9. Install the chain anchors (long anchors) to the back side of the inner upright lower crossmember.
10. Pull the main lift chains over the chain sheaves and attach to the lower inner upright chain anchors.
11. Install the free lift chain anchors (short anchors) and chains to the inner upright center crossmember.
12. Install the free lift cylinder supply hose through the hole in the outer upright top crossmember and over the sheave on the intermediate top upright.
13. Install the carriage as described in Section 4.5-3.
14. Install the free lift cylinder as described in Section 5.2-6.
15. Install the internal reeving sheave and hoses (if equipped) as described in Section 2.4.
16. Turn the mast over.
17. Install the main lift cylinders as described in Section 5.2-5.
18. Install the mast to the truck as described in Section 5.1.
19. Adjust the main lift and free lift chains as described in Sections 5.6-3 and 5.6-4. Check for mast skewing as described in Section 5.5-6.

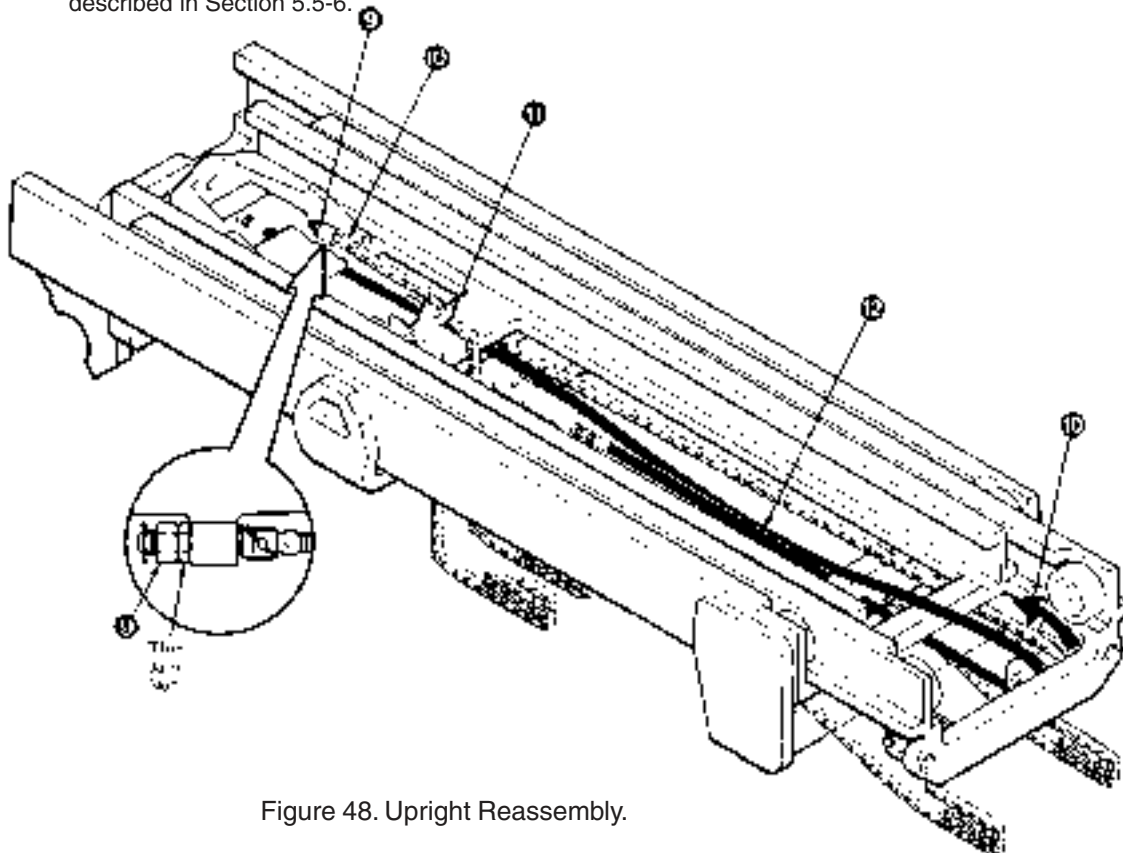

Figure 48. Upright Reassembly.

Section 5 Service

5.5-6 Mast Skewing

1. Extend the mast to the full lift height.

*If the mast kicks to the right at full extension, a shim (part no. 200524) needs to be installed to the right hand main lift cylinder rod.

*If the mast kicks to the left at full extension, a shim (part no. 200524) needs to be installed to the left hand main lift cylinder rod.

2. Place a 6 in. (15 cm) long, 2 X 2 in. (5 X 5 cm) angle iron between the top of the main lift cylinder and the crossmember. See Figure 45. Lower the crossmember onto the angle iron.
3. Remove the snap ring from the cylinder to be adjusted. Open the truck valve to allow the center (free lift) cylinder to fully retract. Tap the main lift cylinder rod down past the crossmember to install the shim.
4. Slowly hydraulically power the main lift cylinder back into the crossmember and reinstall the snap ring.
5. Repeat steps through until skewing is removed.

WARNING: The intermediate upright must be supported by angle iron to avoid possible injury.

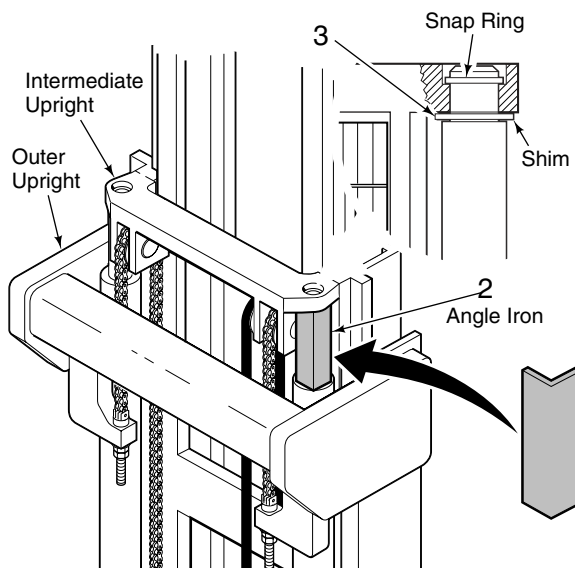

Figure 49. Shim Installation.

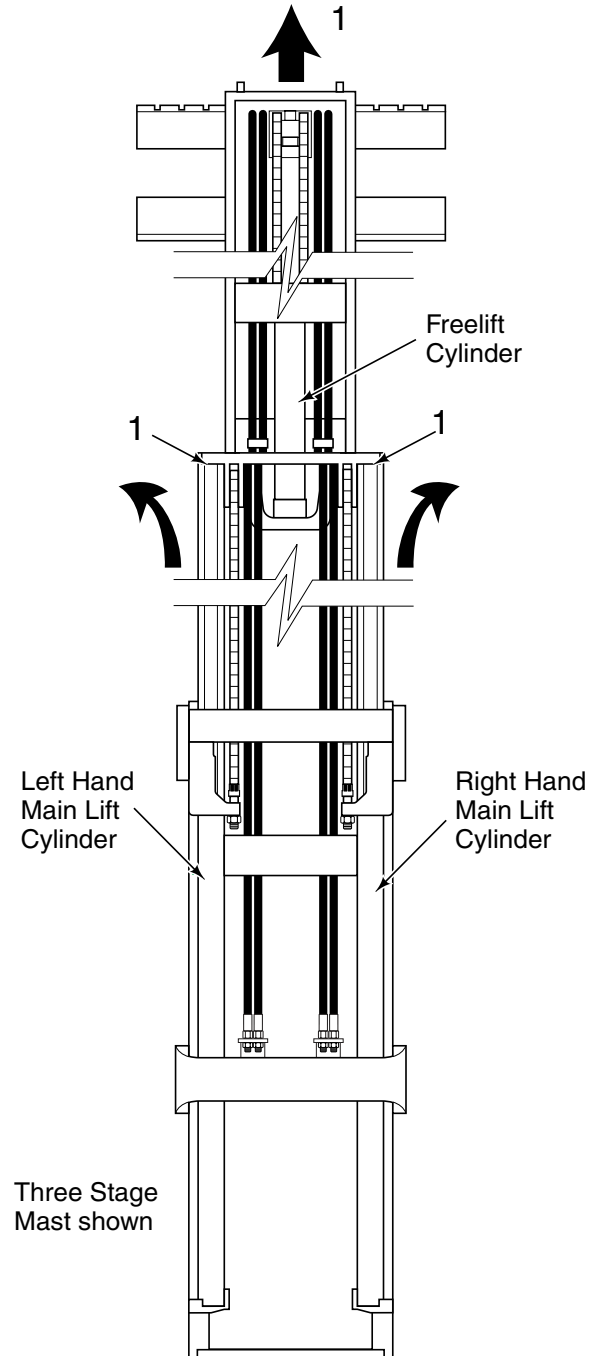

Figure 50. Extended Upright.

Section 5 Service

5.6 Chains

5.6-1 Inspection and Tension

Each pair of chains has been factory-lubricated using heat and pressure to force the lubricant thoroughly into the chain links. Avoid removal or contamination of this factory applied lubricant. **Do not wash, sand blast, etch, steam clean, or paint the chains on initial mast installation.**

The chains must be adjusted with equal tension to ensure proper load distribution and mast operation. To determine equal tension, extend the unloaded mast to put the chains under tension. Press the center of a strand of chain with your thumb, then press at the same place on the other chain of the pair. Each chain in a pair should have equal "give". If tension is not equal, adjust the chains as described in **Chain Adjustment**.

Inspect the chains. If inspection reveals that one strand of a pair of chains requires replacement, **both** strands of the pair should be replaced.

*Check for rust and corrosion.

*Check for cracked side plates. If you find cracked side plates, replace **both** strands of chain.

*Check for tight joints. If tight joints are caused by rust or corrosion, loosen them with SAE 40 wt. oil or penetrating oil. If they cannot be loosened, or if the tight joints are caused by bent pins or plates or by peened plate edge, replace **both** strands of the chain.

*Check for protruding or turned pins. Replace **both** strands of the chain.

*Check for chain side wear. If pins and outside plates show signs of wear, check for misalignment of sheaves, anchors or other components. Correct the misalignment. If wear is excessive, replace **both** strands of chain.

*Check for worn, broken or misaligned chain anchors. Replace or adjust as required.

*Lubricate the full length of the chains with SAE 40 wt. oil or Bowman Heavy Load Red Grease.

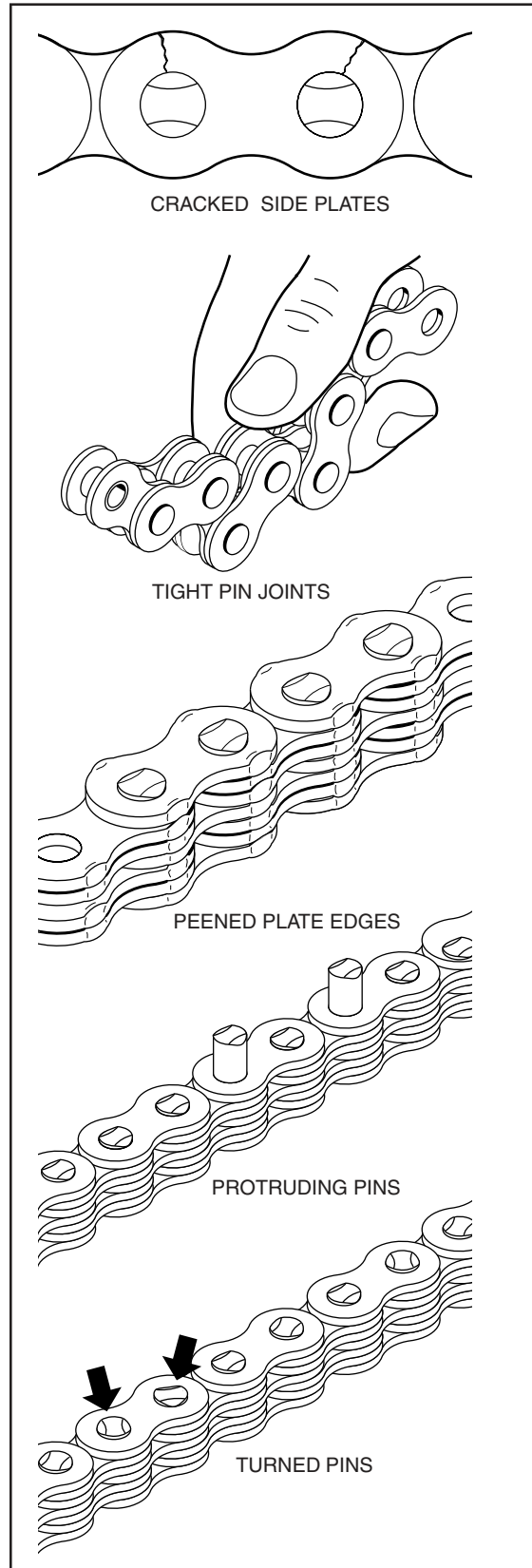

Figure 51.Chain Inspection.

Section 5 Service

5.6-2 Measuring Chain Stretch

Regular inspection and lubrication of the chains will increase their service life and reduce downtime.

If the chains stretch beyond the recommended amount, they should be replaced in pairs. Chain stretch can be measured with chain wear scale. Measure the chains according to the instructions printed on the chain wear scale, without a load on the carriage.

*to check the free lift chains, raise the carriage 1 ft. (30 cm) off the ground to put tension on the chains.

*To check the main lift chains, raise the mast until the inner upright starts to extend ensuring tension on the chains.

Main Lift Chain Adjustment

5.6-3 The main lift chains should be adjusted so that when the unloaded mast is fully lowered, the uprights are positioned as shown in figure 53.

1. Adjust one chain to achieve the correct upright position when fully lowered. See Figure 55.
2. Adjust the other chain to achieve equal chain tension. Tighten the nuts together to a torque of 50-70 ft.-lbs. (98-96 Nm).
3. Raise and lower the mast several times to confirm the adjustments.

Free Lift Chain Adjustment

5.6-4 The free lift chains should be adjusted so that when the unloaded mast is fully lowered, the upright channels and carriage are positioned as shown in Figure 53.

1. Locate the threaded chain anchors on the front side of the inner upright crossmember on each side of the cylinder. Adjust one chain to achieve the correct upright position when fully lowered. See Figure 54.
2. Adjust the other chain to achieve equal chain tension. Tighten the nuts together to a torque of 50-70 ft.-lbs. (68095 Nm).
3. Raise and lower the mast several times to confirm the adjustments.

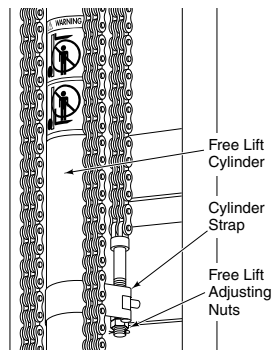

Figure 54. Free Lift Chains.

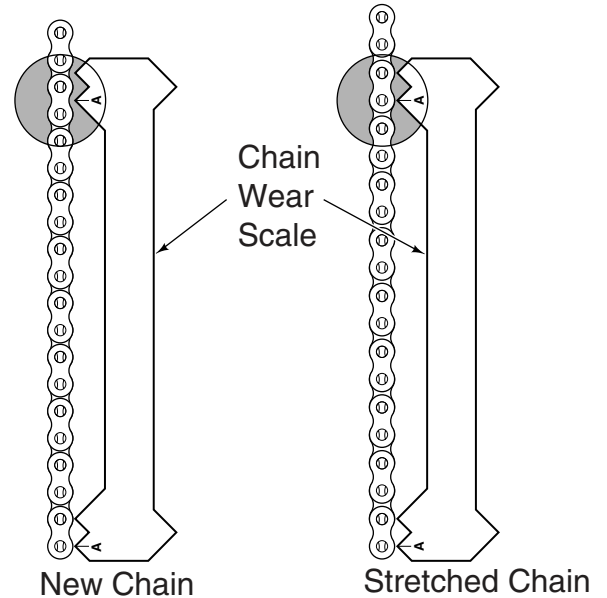
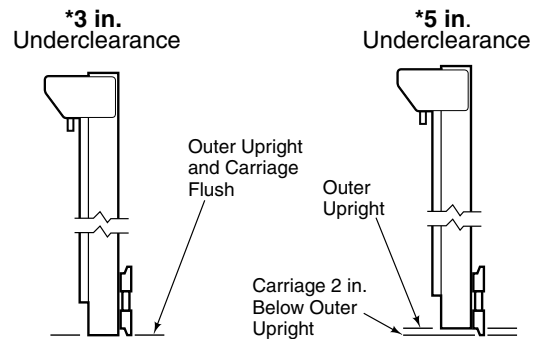

Figure 52. Measuring Chain Stretch.



NOTE: Underclearance is based on mast production series, actual mast underclearance may vary by truck model.

Figure 53. Upright and Carriage Position.

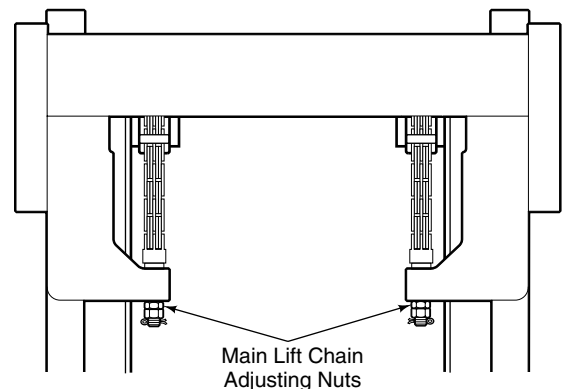

Figure 55. Main Lift Chains.

Section 5 Service

5.6-5 Main Lift Chain Service

WARNING: The intermediate upright must be supported by a block to avoid possible injury.

1. Raise the inner upright 3 ft. (90 cm). Place a 3 ft. (90 cm) block under the free lift cylinder support casting, then lower the cylinder support onto the block. The main lift chains should be slack. See Figure 51.
2. Remove the cotter pins and pins from the chain anchors. Remove the chains.
3. Inspect the chain anchors for cracks. Replace as required.
4. For reassembly, reverse the above procedures. Adjust the chains as described in Section 5.6-3.

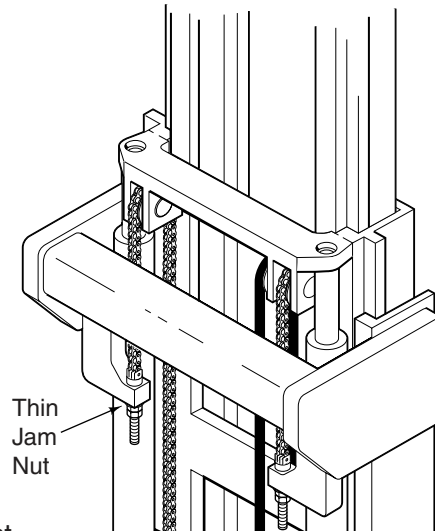

Figure 56. Main Chains.

5.6-6 Free Lift Chain Service

WARNING: The carriage must be supported by a block to avoid possible injury.

1. Raise the carriage 12 in. (30 cm). Place a 12 in. (30 cm) block under the carriage, then lower the carriage onto the block. The free lift chains should be slack. See Figure 52.
2. Remove the cotter pins and pins from the chain anchors. Remove the chains.
3. Inspect the chain anchors for cracks. Replace as required.
4. For reassembly, reverse the above procedures. Adjust the chains as described in Section 5.6-4.

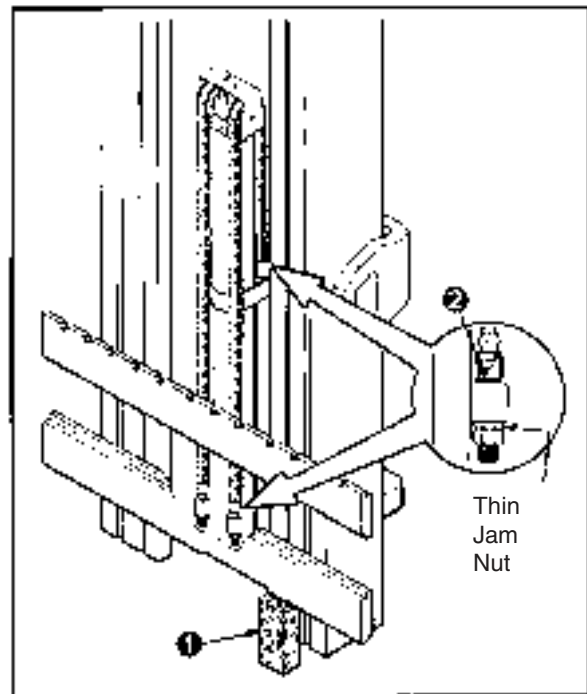

Figure 57. Free Lift Chains.

Supplier Provided Documentation - Mast

Disclaimer:

The documentation provided here within Chapter 5, "Supplier Provided Documentation", has been appended to this Landoll Maintenance Manual for reference only.

The specific contents of this information is not the responsibility of Landoll Corporation or any of its affiliates.

Lift Technologies Inc.

F60 MT 3-Stage Mast (High Lift)

Table of Contents - page 4

Proceed to the above "Table of Contents" starting on page 4, to the Mast Installation, Periodic Maintenance, Troubleshooting and Service instructions as required.

P ARTS MANUAL

This manual contains standard production
Product Identification Numbers.

Special Engineered Options not included.

F60 MT **Triple Stage Mast**

FOR PARTS AND SERVICE:
TELEPHONE: (888) 946-3330

Manual Number:
270848 R0



About This Manual

Introduction

This manual shows the parts breakdown for the most product ID numbers. Locate the product ID number (PID) stamped on the front upper tie bar on the left hand side. This number must be used when ordering replacement parts for this product.

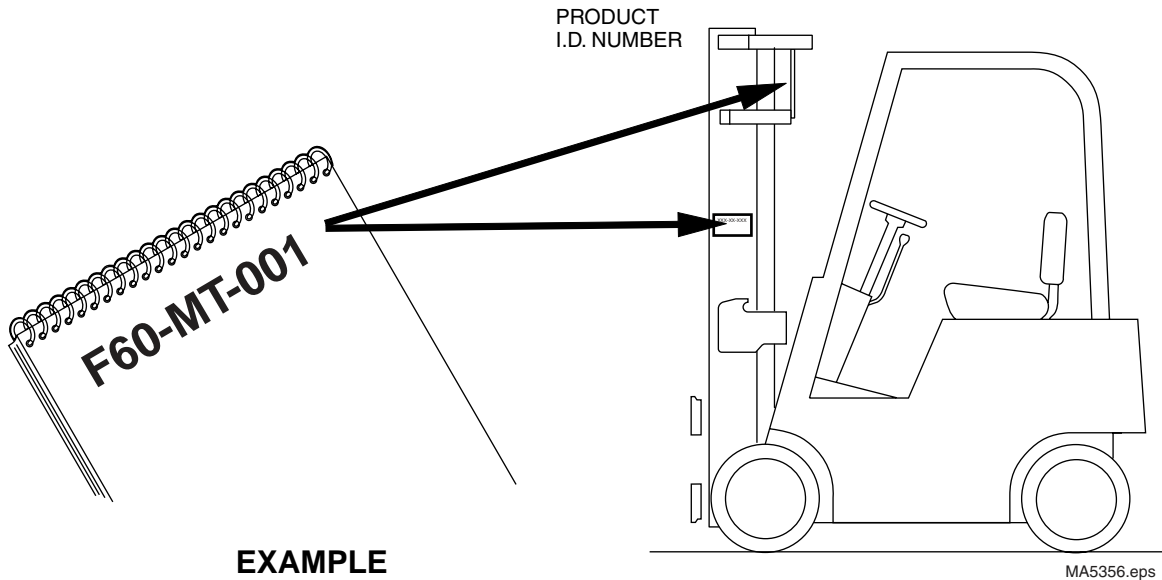

Ordering Parts

Customers -

Parts and service literature is available through authorized lift truck dealers. To place an order, contact the lift truck dealer of your choice.

Lift Truck Dealers -

To order parts and service literature contact:

LIFT-TEK / ELECAR
CUSTOMER SERVICE
7040 S HWY 11
WESTMINSTER, S.C. 29693
TELEPHONE: (877) 430-6302
LOCAL (864) 647-6302
FAX: (864) 647-7302

Contents

Cover.....	1
Introduction.....	2
Safety Decals.....	3
Freelift Cylinder.....	4
Mainlift Cylinder.....	6
Weldments.....	8
Hoist Chain Routing.....	9
Lowering Control Valve.....	10
4 Roller Carriage.....	11
Single Internal Hose Reeving.....	12
Double Internal Hose Reeving.....	13
Recommended Spare Parts List.....	14

Safety Decals

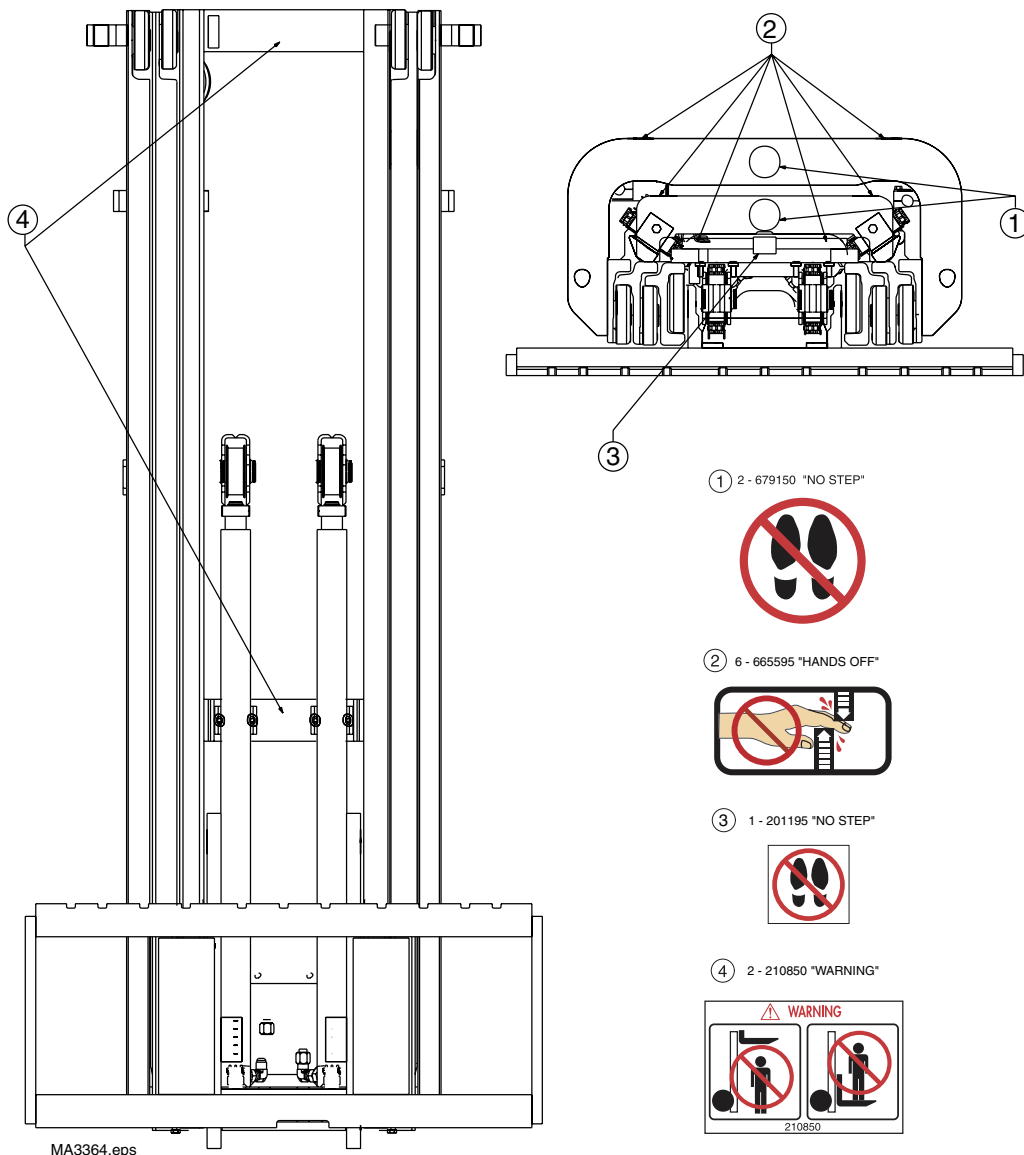

Freelift Cylinder

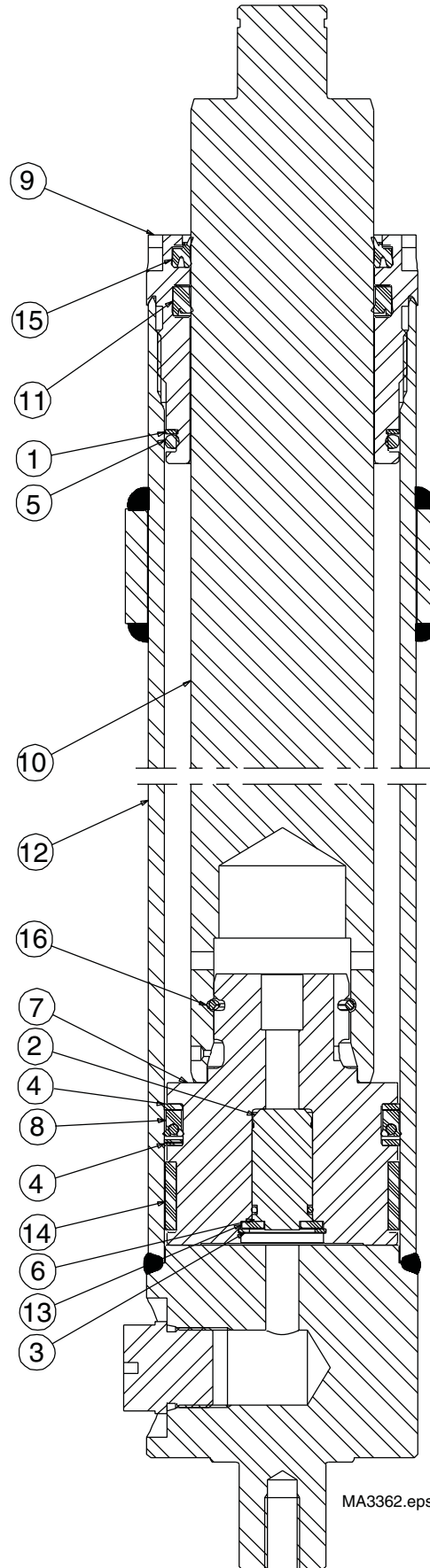

Freelift Cylinder

Common Parts

FL-1

Item #	Qty	Part #	Description
1	1	S, R	Back up ring
2	1	C	Check valve
3	1	S, C	Circlip
4	1	S, C	Nylon ring
5	1	S, R	O-Ring
6	1	S, C	O-Ring
7	1	P	Piston
8	1	S	Piston seal
9	1	R	Retainer
10	1	P	Rod
11	1	S, R	Rod seal
12	1	N/A	Shell assembly
13	1	S, C	Washer
14	1	S	Wear ring
15	1	S, R	Wiper
16	1	P	Wire ring

S - Included in Seal Kit P/N 3105187

P - Not Available.

C - Included in check valve kit P/N 563904.

R - Included in Retainer Kit P/N 3106703-SUB.

Cylinder P/N

*OCL (in)	RH FL Cylinder Part #	LH FL Cylinder Part #
130	1007484	1007483
152	1007739	1007740
168	1007741	1007742
174	1007743	1007744
190	1007745	1007746

* OCL - Outer channel length.

Mainlift Cylinder

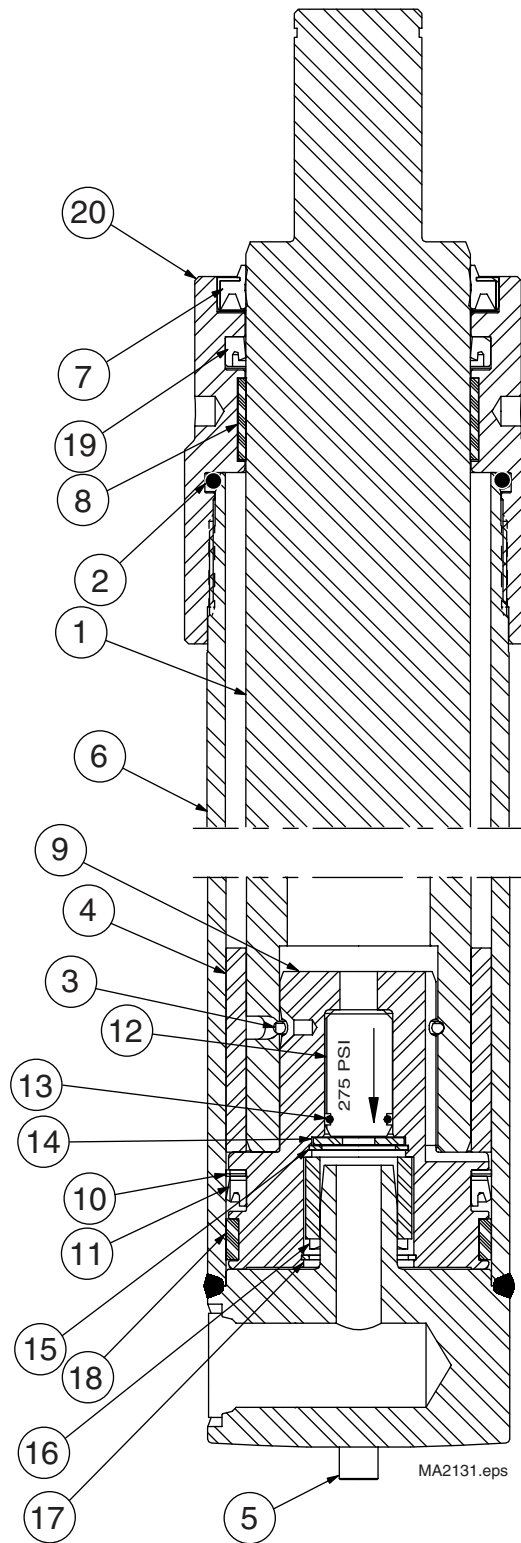

Mainlift Cylinder

Components

ML-1

Item #	Qty	Part #	Description
1	1	N/A	Rod/Plunger
2	1	S, R	O-Ring
3	1	S	Pull Wire
4	1	N/A	Spacer
5	2	N/A	Roll Pin
6	1	N/A	Shell/Case
7	1	S, R	Wiper
8	1	S, R	Bushing
9	1	N/A	Piston
10	1	S	Nylon Ring
11	1	S	Piston Seal
12	1	C	Check Valve
13	1	S,C	O-Ring
14	1	C	Washer
15	1	S,C	Circlip
16	1	219768	Sleeve
17	1	S,C	Retaining Ring
18	1	S	Wear Ring
19	1	S, R	Rod Seal
20	1	3102957	Retainer/Gland

S - Included in Seal Kit P/N 1002528.

C - Included in Check Valve Kit P/N 563904.

Cylinder P/Ns

*OCL (in)	ML Cylinder Part #
130	1007482
152	1007735
168	1007736
174	1007737
190	1007738

*OCL - Outer channel length.

Weldments

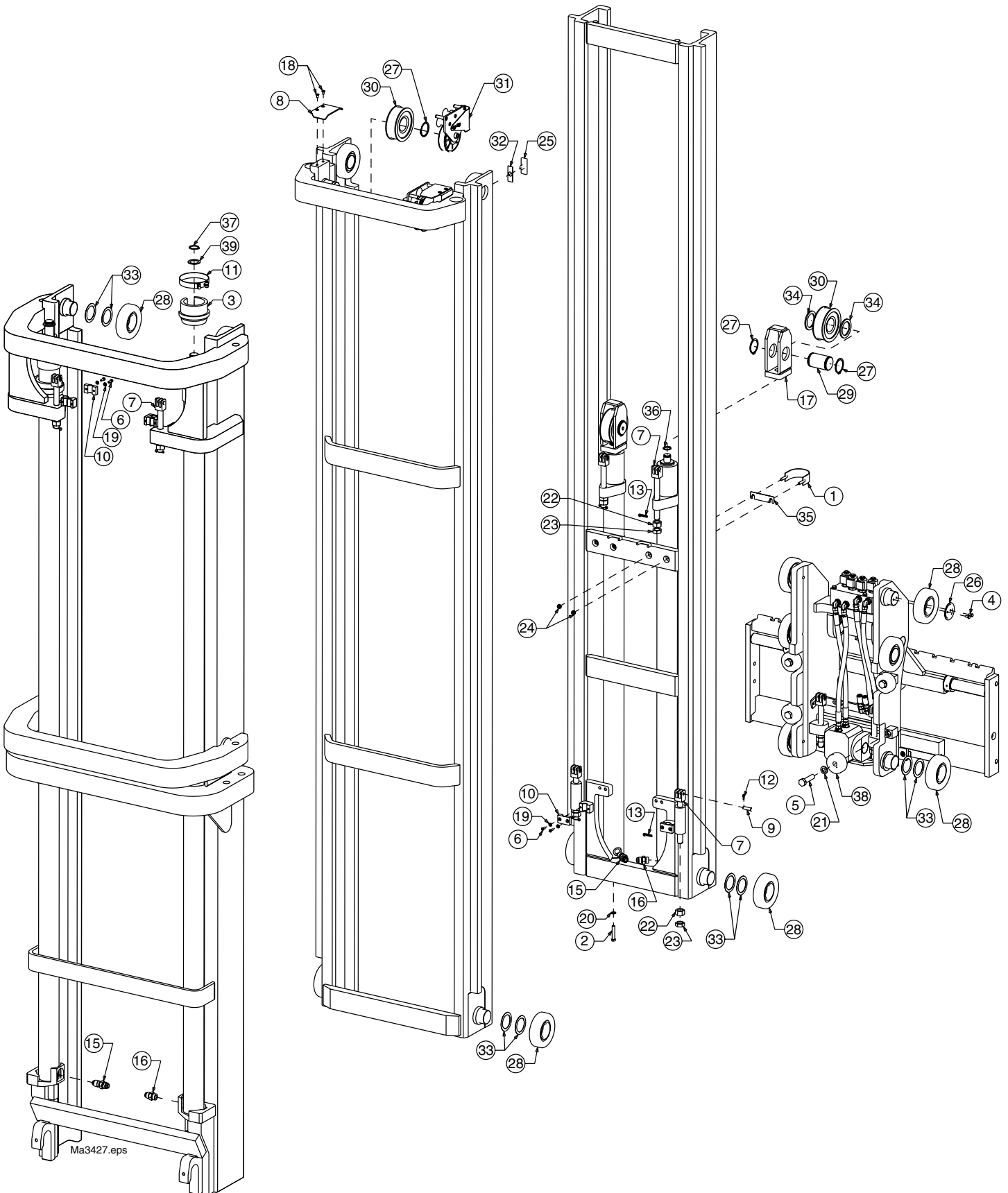

Common Parts Group 270001

270001

Item #	Qty	Part #	Description	Item #	Qty	Part #	Description
1	2	269161	BAND, FL CYL	21	4	684586	LOCKWASHER M16
2	2	643530	BOLT	22	8	200242	NUT HEX FULL
3	2	248890	BUMPER	23	8	200244	NUT HEX JAM
4	4	680218	CAPSCREW HEX HEAD	24	4	767414	NUT M8
5	4	220495	CAPSCREW M16X2X65	25	4	223078	PLUG WEAR
6	8	682662	CAPSCREW M6 X 16	26	2	222617	RETAINER
7	8	679144	CHAIN ANCHOR	27	6	3147	RETAINER CLIP
8	2	269205	CHAIN GUARD	28	14	688169	ROLLER ASSY
9	8	679149	CHAIN PIN	29	2	269209	SHAFT
10	4	923868	CLAMP	30	4	223071	SHEAVE
11	2	248978	CLAMP	31	2	927156	SHEAVE ASSEMBLY
12	8	6508	COTTER PIN	32	4	215722	SHIM
13	8	6518	COTTER PIN	33	*28	637536	SHIM
14	1	257917	DECAL KIT	34	4	269285	SHIM
15	2	224480	EXT FUSE VALVE-20.5GPM	35	2	269342	SHIM PLATE
16	2	611291	FITTING	36	2	688935	SNAP RING 1.00 DIA
17	2	269139	FL CROSSHEAD	37	2	3135	SNAP RING 1.25" DIA
18	4	766496	FLAT HEAD CAPSCREW	38	4	688168	THRUST ROLLER ASSY
19	8	202346	FLAT WASHER M6	39	2	205196	WASHER SHIM
20	2	4E6ER	LOCK WASHER				

* - Quantity will vary.

Hoist Chain Routing

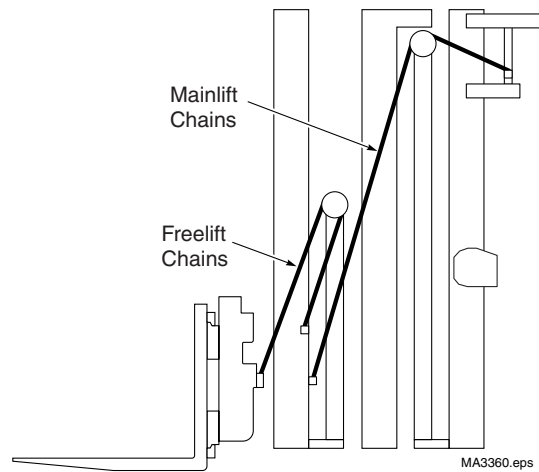

Weldments, Chains and Hoses

WLD-1

*OCL (in)	Outer Upright	Intermediate Upright	Inner Upright	Freelift Chain Qty 2	Mainlift Chain Qty 2	Freelift Hose Qty 2
130	269272	269271	269270	678806	263146	269353
152	269936	269948	269952	678808	270009	270005
168	269937	269949	269953	213370	270010	270006
174	269938	269950	269954	206005	270011	270007
190	269939	269951	269955	227340	270012	270008

*OCL - outer channel length.

Lowering Control Valve

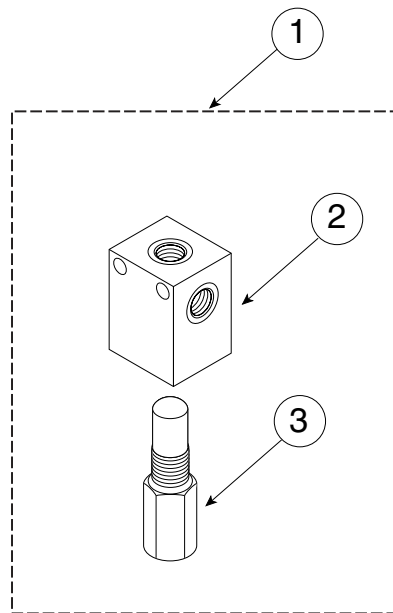

LCV 246670

Item #	Qty	Part #	Description
1	1	246670	VALVE ASSEMBLY
2	1	246669	VALVE BODY
3	1	689642	FLOW VALVE

6 Roller Tilt Carriage

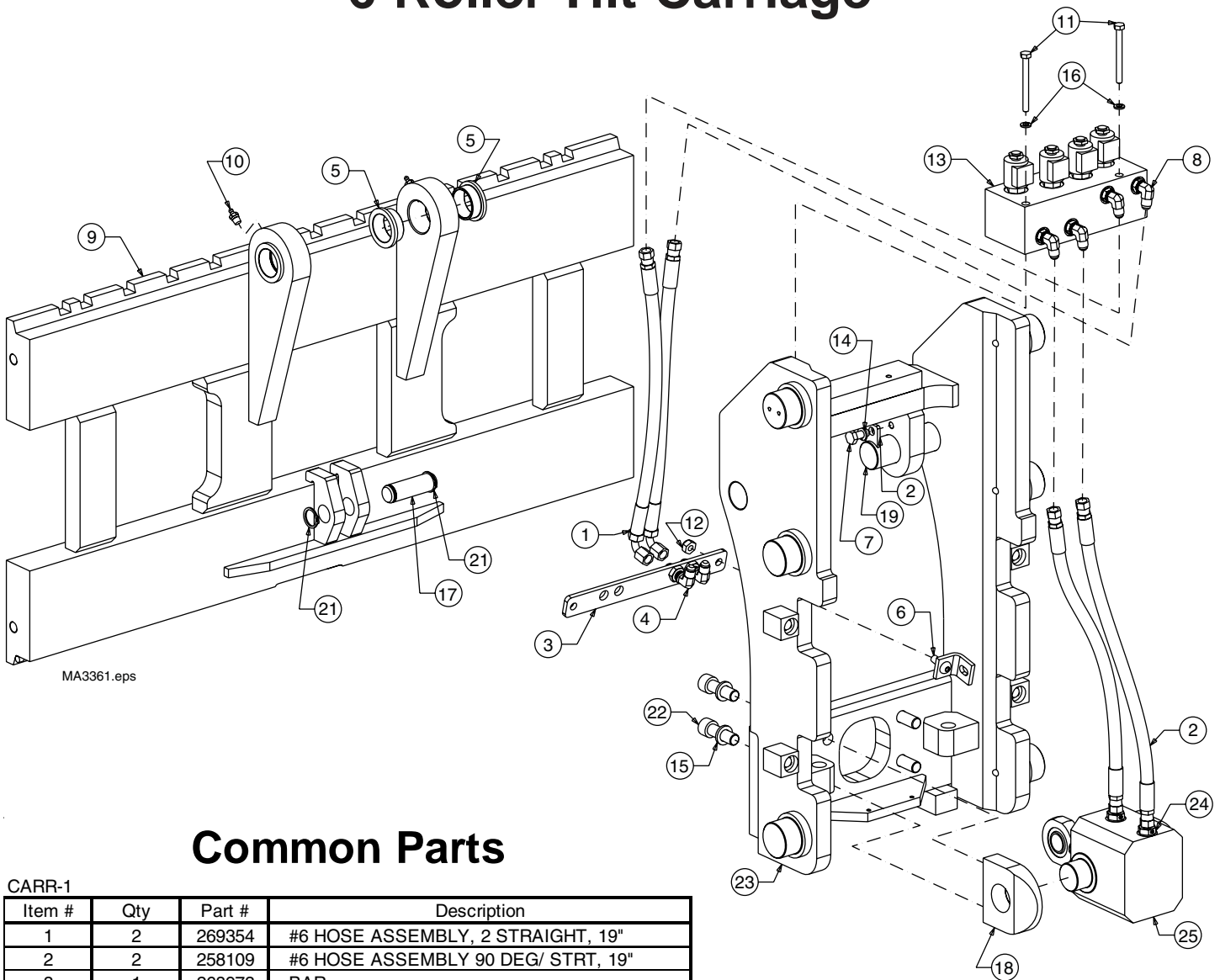

MA3361.eps

Common Parts

CARR-1

Item #	Qty	Part #	Description
1	2	269354	#6 HOSE ASSEMBLY, 2 STRAIGHT, 19"
2	2	258109	#6 HOSE ASSEMBLY 90 DEG/ STRT, 19"
3	1	268973	BAR
4	2	2453	BULKHEAD UNION 90 DEG
5	4	268972	BUSHING
6	2	206318	CAPSCREW BUTTONHEAD M10
7	2	684649	CAPSCREW M10X25 LG
8	4	601676	FITTING
9	1	S-16800	FRONT FRAME WELDMENT
10	2	253457	GREASE FITTING
11	2	768533	HEX HEAD CAP SCREW
12	2	786882	HEX NUT M10
13	1	269268	HYDRAULIC CONTROL VALVE
14	2	681238	LOCKWASHER M10
15	4	684586	LOCKWASHER M16
16	2	206315	LOCKWASHER M8
17	1	269186	PIN
18	2	268933	PIVOT PLATE
19	2	269214	PIVOT SHAFT
20	2	269215	RETAINER PLATE
21	2	688935	SNAP RING 1.00 DIA
22	4	769577	SOCKET HEAD CAPSCREW
23	1	S-16813	SPINE WELDMENT
24	2	269259	STRAIGHT FITTING
25	1	1007485	TILT CYLINDER

Components

CARR-2

Carriage Assembly	WIDTH	ITA Class	Spine	Front Frame
269279LB	42"	III	269277LB	269278LB

Contact Lift Technologies, Inc. Customer Service if your carriage does not match any of those listed
(Mast PID number needed).

6 Roller Tilting ISS

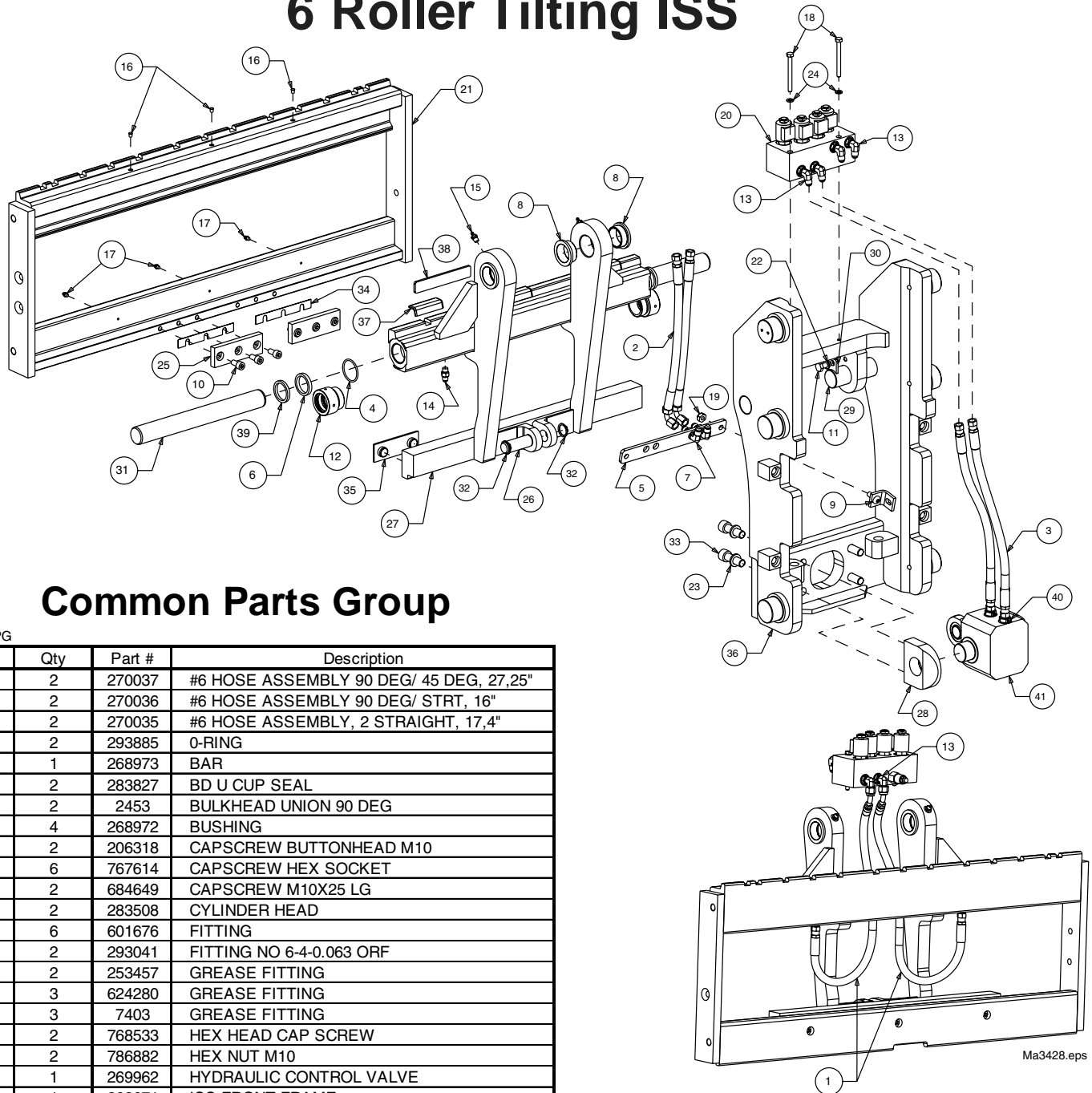

Common Parts Group

s16862CPG

Item #	Qty	Part #	Description
1	2	270037	#6 HOSE ASSEMBLY 90 DEG/ 45 DEG, 27,25"
2	2	270036	#6 HOSE ASSEMBLY 90 DEG/ STRT, 16"
3	2	270035	#6 HOSE ASSEMBLY, 2 STRAIGHT, 17,4"
4	2	293885	O-RING
5	1	268973	BAR
6	2	283827	BD U CUP SEAL
7	2	2453	BULKHEAD UNION 90 DEG
8	4	268972	BUSHING
9	2	206318	CAPSCREW BUTTONHEAD M10
10	6	767614	CAPSCREW HEX SOCKET
11	2	684649	CAPSCREW M10X25 LG
12	2	283508	CYLINDER HEAD
13	6	601676	FITTING
14	2	293041	FITTING NO 6-4-0.063 ORF
15	2	253457	GREASE FITTING
16	3	624280	GREASE FITTING
17	3	7403	GREASE FITTING
18	2	768533	HEX HEAD CAP SCREW
19	2	786882	HEX NUT M10
20	1	269962	HYDRAULIC CONTROL VALVE
21	1	262671	ISS FRONT FRAME
22	2	681238	LOCKWASHER M10
23	4	684586	LOCKWASHER M16
24	2	206315	LOCKWASHER M8
25	2	283510	LOWER CARRIAGE CLAW
26	1	269888	PIN
27	1	S-16861	PIVOT FRAME WELDMENT
28	2	269999	PIVOT PLATE
29	2	269214	PIVOT SHAFT
30	2	269215	RETAINER PLATE
31	2	262668	SIDESHIFT ROD
32	2	688935	SNAP RING 1.00 DIA
33	4	769577	SOCKET HEAD CAPSCREW
34	2	254563	SPACER
35	3	293977	SPINE BAR WEAR PAD
36	1	S-16860	SPINE WELDMENT
37	3	283512	SS CYLINDER TOP WEAR PAD
38	1	283617	SS CYLINDER FACE WEAR PAD
39	2	283632	SS CYLINDER ROD WIPER
40	2	269259	STRAIGHT FITTING
41	1	1007732	TILT CYLINDER

Assembly and Component P/Ns

s16862wld

ISS Assembly Part #	Width	ITA Class	Sideshift	Spine Part #	Pivot Frame Part #	Front Frame Part #
270038LB	1041,4mm (41")	II	142mm	270033LB	270034LB	262671LB

Single Internal Hose Reeving

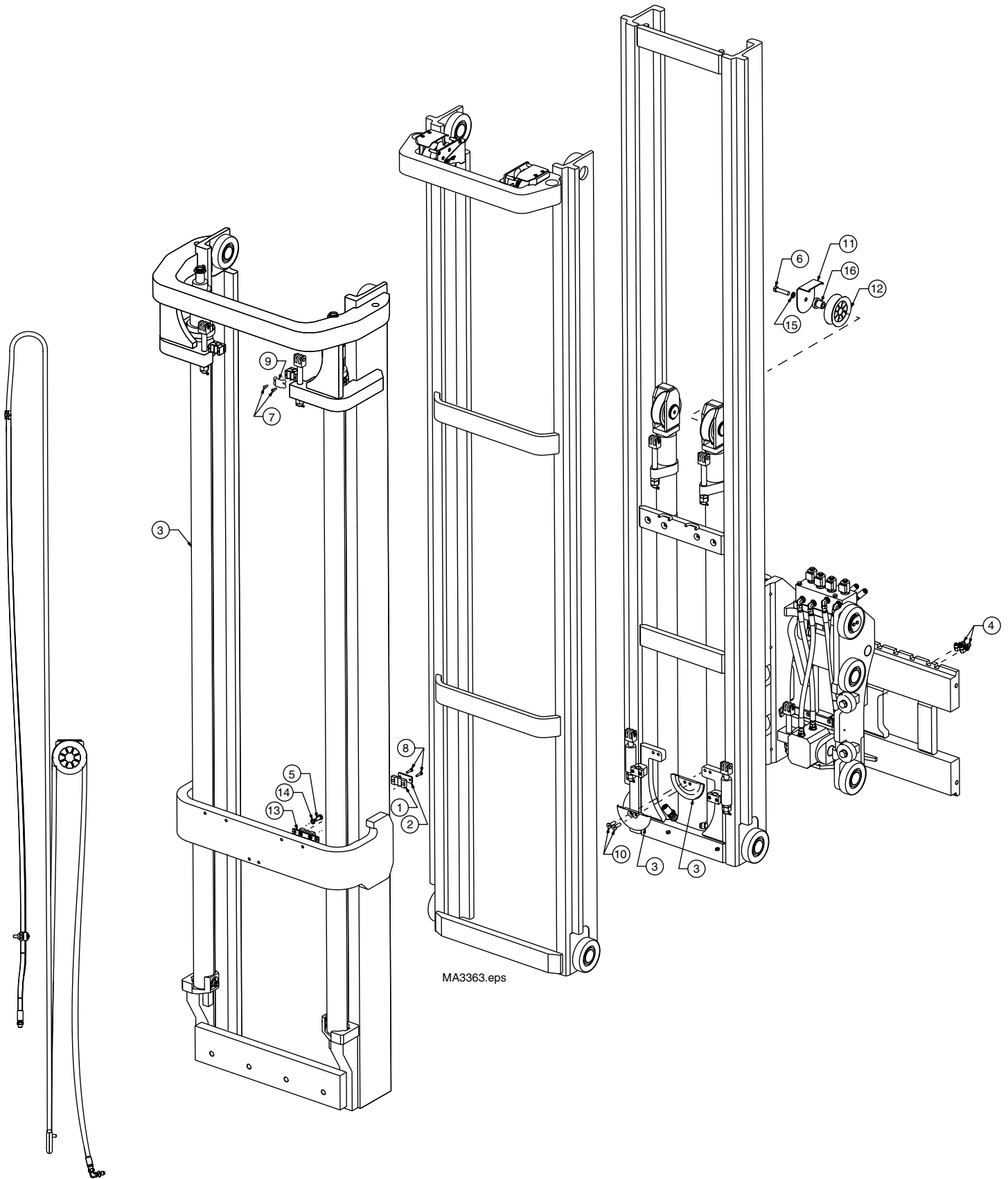

IHR Hose Routing

Common Parts Group P/N 269294

IHR-1

Item #	Qty	Part #	Description
1	2	227855	(2) HOSE CLAMP
2	1	227884	BAR, HOSE CLAMP
3	2	269211	U-TURN HOSE CLAMP
4	2	2453	BULKHEAD UNION 90 DEG
5	2	684649	CAPSCREW M10X25 LG
6	1	205206	CAPSCREW M12X55
7	2	682662	CAPSCREW M6 X 16
8	2	762900	CAPSCREW M6X25 LG
9	1	920347	CLAMP
10	2	768699	FLAT SOCKET HD CAPSCREW
11	1	269212	HOSE GUARD
12	1	677267	I.H.R. SHEAVE
13	1	232744	IHR BRACKET
14	2	681238	LOCKWASHER M10
15	1	683822	LOCKWASHER M12
16	1	210216	STUBSHAFT

Kits and Hoses

s16826wld

OCL (in)	IHR Kit Part #	Hoses Qty 2
130	269295	269357
152	270022	270018
168	270023	270019
174	270024	270020
190	270025	270021

*OCL - Outer channel length.

Double Internal Hose Reeving

For double IHR, use qty 2 single IHR kits.

Recommended Spare Parts List

F60 MT				
PART #	DESCRIPTION	MASTS SERVICED		
		1-5	6-19	20-50
FREELIFT LIFT CYLINDERS				
n	FreeLift Cylinder Assembly	0	0	1
561242	Piston Kit	1	2	4
3106703-SUB	Retainer Kit	1	2	4
560349	Seal Kit	1	2	4
563904	Check Valve Kit	1	2	4
MAINLIFT LIFT CYLINDERS				
n	FreeLift Cylinder Assembly	0	0	2
3102957-SUB	Retainer Kit	2	4	8
1002528	Seal Kit	2	4	8
563904	Check Valve Kit	2	4	8
UPRIGHTS				
223078	Wear Plug	4	8	16
3147	Retainer clip	6	12	24
688169	Roller Assmbly	14	28	56
215722	Shim	4	8	16
637536	Shim	28	56	112
269285	Shim	4	8	16
688935	Snap ring	2	4	8
3135	Snap ring	2	4	8
688168	Trust Roller Assembly	4	8	16
205196	Washer Shim	2	4	8
CARRIAGE AND CHAINS				
n	Free Lift Chains			
n	Mainlift Chains			
269354	#6 hose assembly	2	4	8
258109	#6 hose assembly	2	4	8
268972	Bushing	4	8	16
269268	Hydraulic control valve	1	2	4
269186	Pin	1	2	4
688935	Snap ring	2	4	8
664206	Roller	2	4	8
IHR				
677267	Sheave	1	2	4

n See Specific charts for part numbers

Document Control Revision Log:

Date	Revision	Improvement(s) Description and Comments
12/15/11	F-594-R1	Initial Release- Joshua
09/10/12	F-594-R2	Included additional information for HL Masts
nn/nn/nn	F-	



Intertek

Equipment from Landoll Corporation is built to
exacting standards ensured by ISO 9001 registration
Landoll manufacturing facilities.

Bendi B55AC / Bendi B55AC HL

Maintenance Manual

Re-Order Part Number F-594-R2

LANDOLL CORPORATION

1900 North Street

Marysville, Kansas 66508

(785) 562-5381

800-428-5655 ~ WWW.LANDOLL.COM



Copyright 2012. Landoll Corporation

“All rights reserved, including the right to reproduce this material or portions thereof in any form.”