



Model B3/30 AC
Electric Narrow Aisle Forklift
Operator's Manual



LANDOLL CORPORATION

1900 North Street
Marysville, Kansas 66508
(785) 562-5381

800-428-5655 ~ WWW.LANDOLL.COM

1 Safety and Familiarity

- Before You Begin (Please Read) 1-1**
- Site Supervision 1-1**
- Terminology and Illustrations Used in Manual 1-2**
- Understanding Safety Statements 1-2**
- Lock Out/Tag Out 1-2**
- B3/30 AC Decals and Placement 1-3**
- Operator Safety 1-5**
- Operator Safety Training 1-6**
 - Seat Belt 1-6
 - Seat Safety Switch 1-6
 - Parking Brake 1-6
- Tipping Hazards and Conditions 1-6**
 - Longitudinal Tipping 1-6
 - Lateral Tipping 1-7
 - Longitudinal or Lateral Tipping 1-7
- Traveling and Load Handling 1-7**
 - Speed 1-8
 - Visibility 1-8
- Battery Safety 1-8**
- Battery Safety Rules: 1-9**
 - Battery Care and Charging 1-9
 - Battery Removal and Installation 1-9
 - Good Battery Care Requirements: 1-10
 - In Case of a Fire! 1-10
- Service and Repair Safety 1-10**

2 Receiving and Inspection

Items Furnished With Your Truck	2-1
Items Required	2-1
Tools and Test Equipment	2-1
Preparing the Truck	2-1
Inspecting the Truck	2-1
Visual Inspection	2-1
General Walk Around	2-2
Battery Restraint	2-2
Service Brakes	2-2
Driver's Seat	2-2
Fasteners	2-2
Horn, Lights, etc.	2-2
Hydraulic Lines and Loose Fittings	2-3
Hydraulic Oil Level	2-3
Dash Display	2-3
Mast Operation	2-3
Overhead Guard	2-3
Parking Brake	2-3
Rust Or Corrosion	2-3
Safety Decals, Data Plates, etc.	2-3
Static Discharge Strap	2-3
Tires and Wheels	2-4
Welds, Cracked or Broken	2-4
Wires or Connectors	2-4
Fire Extinguisher Option	2-4
Storage, Towing or Shipping	2-4
Truck Storage	2-4
Towing the Truck	2-5
To Ship the Truck	2-5

3 Understanding the Bendi B3/30 AC Forklift

Vehicle Description	3-1
Truck Identification	3-2
Identification Plate	3-2
Bendi B3/30 AC Serial Number Code	3-4
Understanding Truck Rated Capacity	3-4
Truck Overview	3-4
Frame	3-4
Steering	3-4
Brake System	3-4
Electrical System	3-4
Traction	3-4
Keyswitch	3-5
Safety Interlock	3-5
Battery	3-5
Emergency Interrupt	3-6
Hydraulic System	3-6
Mast Controls	3-6
Mast Lift	3-6
Mast Tilt	3-6
Mast Side Shift	3-6
Mast Lift Assemblies	3-6
Driver Controls	3-8
Foot Control Pedals	3-8
Hand Operation Controls	3-8
Parking (Hand) Brake	3-8
Direction Lever	3-8
Lift Lever	3-8
Tilt Lever	3-9
Side Shift Lever	3-9
Horn	3-9
Rear View Mirror	3-9
Driver's Seat	3-9
Seat Belt	3-9
Steering Wheel	3-9
Dash Display	3-9
Understanding Stability	3-10
Basic Principles	3-10
Load Center	3-11
Counterweight	3-11
Maximum Fork Lift Height	3-11
Tilting Considerations	3-12
Attachments	3-12
Determining the Weight of the Load	3-12
Understanding Workplace Conditions	3-12
Working in Hazardous Environments	3-13

4 Operating the Bendi B3/30 AC Forklift

Operator's Daily Inspection	4-1
Basic Operating Instructions	4-1
Getting On and Off the Forklift	4-2
Driving Position	4-2
Starting and Traveling	4-2
Turning	4-2
Intersections	4-3
Stopping	4-3
Parking	4-3
Setting the Forks	4-4
Controls and Indicators	4-4
Accelerator Pedal	4-4
Brake Pedal	4-5
Parking (Hand) Brake	4-5
Direction Control Lever	4-5
Lift Lever	4-5
Tilt Lever	4-5
Side Shift Lever	4-5
Horn	4-5
Seat Switch	4-5
Seat Belt	4-6
Seat Adjustments	4-6
Steering Wheel	4-6
Dash Display	4-7
Emergency Stop	4-7
Slow/Fast (Std) Mode Switch	4-7
Handling a Load	4-7
Retrieving a Load	4-8
Transporting a Load	4-11
Traveling on Inclines	4-11
Unloading The Forklift	4-11

5 Bendi B3/30 AC Daily Operator Checks

Inspections Overview	5-1
Maintenance Schedule	5-1
Daily Checklist	5-1
Tires and Wheels	5-3
Static Discharge Strap(s)	5-3
Battery	5-3
Parking Brake	5-6
Service Brakes	5-6
Check the Brake Fluid Level	5-6
Accelerator Control	5-6
Lift Chains	5-6
Forks	5-6
Electrical Fastener Connections	5-7
Hydraulic Cylinders, Fittings & Hoses	5-7
Hydraulic Oil	5-7
Operator Controls	5-7
Directional Control	5-8
Auxiliary Function Controls (Optional)	5-8
Horn	5-8
Lights and Alarm	5-8
Steering	5-8
Steer Column Tilt & Telescope	5-8
Dash Display	5-9
Seat, Belt, Slides & Switch	5-9
Major Structural Points	5-9
Safety Labels	5-9
Capacity Plate	5-9
Unusual Noises	5-9
General Truck Lubrication	5-9
Recommended Lubricants	5-10
Technical Specifications	5-11

Safety and Familiarity

Before You Begin (Please Read)

This Chapter of the Bendi B3/30 AC Forklift Operator's Manual discusses important safety information regarding the operation and maintenance of your Forklift.

IMPORTANT

The Bendi Series* Model trucks have been designed for optimum safety of their operators. Please follow the safety guidelines listed in this section and adhere to all Important, Caution, Warning, and Danger notices found within this manual.

When the truck is in operation, always keep loose clothing, jewelry, hair and fingers out of the restricted areas (especially pinch areas), as labeled on the truck.

This chapter on Safety must be carefully read, understood and adhered to strictly by all operators and service personnel operating and/or maintaining the Bendi Series Model lift trucks.

Do not use this truck until you have thoroughly read this manual.

Failure to comply could cause risk of death or serious injury to yourself and others.

** Landoll and the Bendi Series are trademarks of the Landoll Corporation. All other brand and product names are the trademarks of their respective holders.*

Landoll Corporation, Bendi Series Model trucks meet or exceed ASME B56.1 - Part III, Safety for Powered Industrial Trucks.

IMPORTANT

NO modifications or additions may be made to this truck without prior written permission from:

**Landoll Corporation
Material Handling Product Group
1900 North Street
Marysville, KS 66508 U.S.A.**

**Telephone: (785) 562-5381
Fax: (785) 562-4853**



WARNING

- **Do not make modifications or additions to electrical devices.**
- **Do not tamper with or disconnect safety features or modify protective guards, such as overhead guards or load backrest extensions.**
- **Do not add or remove structural components.**
- **Any changes could affect truck capacity or safe operation of the truck and is a serious safety violation, that could cause personal injury or weaken the trucks construction.**

Site Supervision

Supervision is an essential element in the safe operation of powered industrial lift trucks. The site supervisor is to check that the Operator's Manual is in the seat compartment on the truck at all times. Operators must be trained on the use, maintenance and safety aspects of the Bendi B3/30 AC Model trucks, under the supervision of a trained and experienced operator. Only those individuals trained to operate and/or service this truck may do so. Familiarization and driving practice with a new truck should be arranged in a safe area, away from other trucks, obstacles and people. The training program is to be applied to all new operators, regardless of previous experience. Operator performance must be evaluated to ensure he/she has the proper skills and knowledge to operate the truck. Operators should be retrained when new equipment is introduced, existing equipment is modified, operating conditions change or an operator's performance is determined unsatisfactory. The truck is to be inspected daily for problems or damage which may risk the drivers safety, people in the work area, or possible damage to the truck and the load being moved. When trucks are used on a round-the-clock basis, they should be inspected after each shift.

Problems found are to be reported and corrected. The truck is to be taken out of operation until all repairs have been made and the truck has been re-inspected for safety.

Terminology and Illustrations Used in Manual

Whenever front and rear, right and left are mentioned throughout this manual, it is assumed that you are seated in the vehicle looking toward the forks.

This manual makes use of many illustrations to help you locate components on your Bendi B3/30 AC forklift and allow you to follow instructions/procedures.

You will notice that most illustrations have an identifying Figure number below the illustration frame. As an example ... "See Figure 1.1".

Understanding Safety Statements

You will find various types of safety information on the following pages and on the machine decals (signs) attached to the vehicle. This section explains their meaning.

The Safety Alert Symbol means ATTENTION! YOUR SAFETY IS INVOLVED!

NOTICE
Special notice - read and thoroughly understand.

 CAUTION
Proceed with caution. Failure to heed caution "may" cause injury to person or damage product.

 WARNING
Proceed with caution. Failure to heed warning "will" cause injury to person or damage product.

 DANGER
Proceed with extreme caution. Failure to heed notice will cause injury or death to person and/or damage product.

NOTE

You should read and understand the information contained in this manual and on the machine decals before you attempt to operate or maintain this forklift.

NOTICE
In the interest of operator safety and in compliance with OSHA regulations, guidelines have been developed for performing service and maintenance on the truck.
Before performing service and maintenance on the truck, review the following sections in this manual for additional procedures to be followed.

Lock Out/Tag Out

IMPORTANT

When doing maintenance or repair on the Bendi B3/30 AC truck, unless the truck must be on for testing, remove the key from the Keyswitch. In addition, because it's possible to have a duplicate key, remove the main power fuse and install a commercially available Lock Out/Tag Out device on the battery connectors. Also, install a lockout warning reminder on the steering wheel warning that the truck is not available for use.

B3/30 AC Decals and Placement

The location of each machine sign on the Bendi B3/30 AC forklift is illustrated on the next page. See Figure 1-1. A list of each machine decal is on the following page, See Figure 1-2.

Make sure you check each machine sign before you operate your Bendi B3/30 AC forklift and replace any that are no longer legible, missing or damaged.

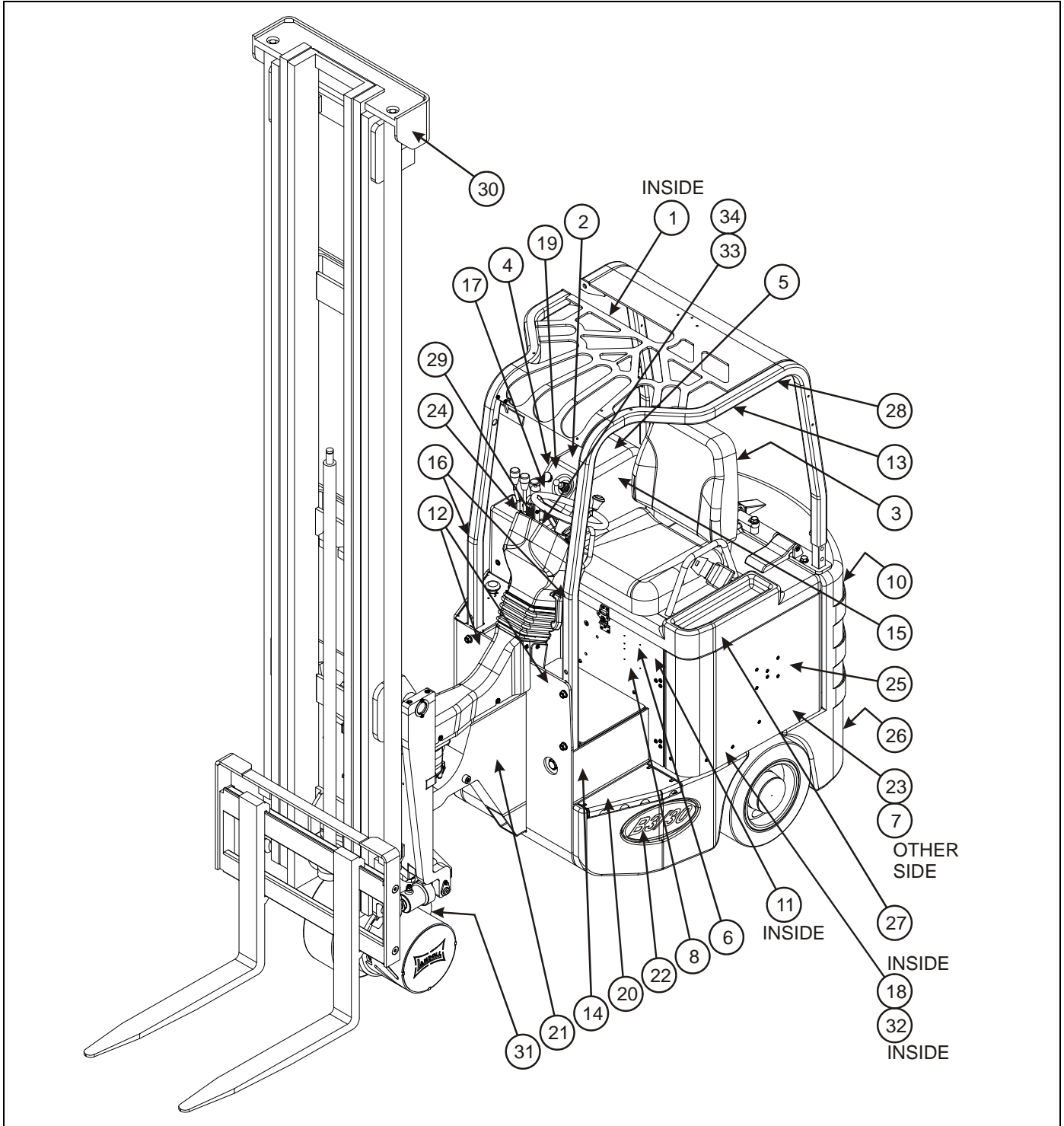

Figure 1-1: Bendi B3/30 AC Forklift Decal Placement

SAFETY AND FAMILIARITY

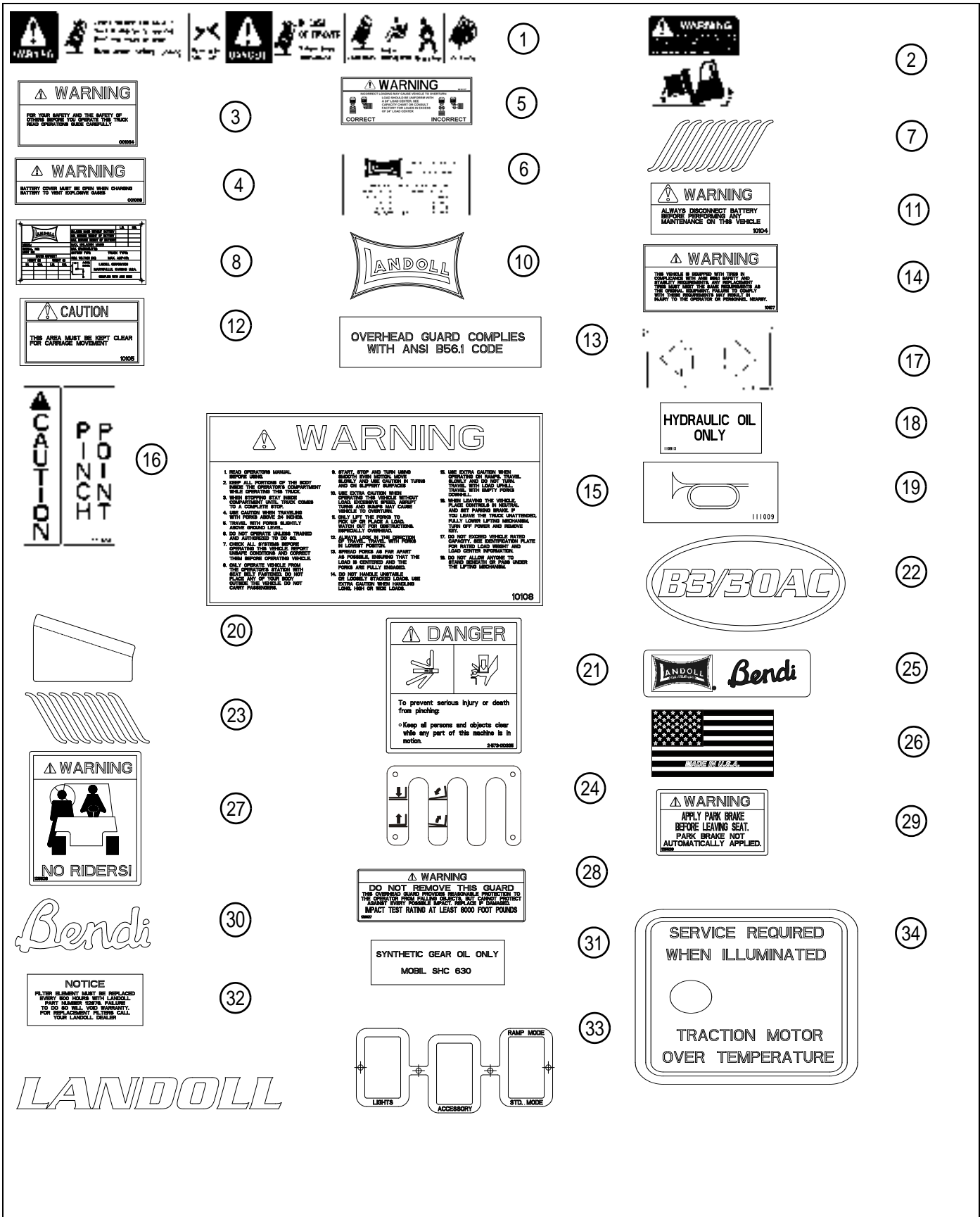

Figure 1-2: Decals

Operator Safety



WARNING

- Check that all directional controls are in their **NEUTRAL** position and your seat belt is fastened before setting the Keyswitch to **ON**, see “Seat Belt” on page 1-6.
 - To avoid personal injury when operating the truck, be extremely careful that **NO** part of your body (head, feet, arms, legs, fingers) is outside the operator’s compartment, subject to injury by aisle supports, other trucks or any obstacle in the area.
 - Know the location of and be especially careful of all pinch points, as indicated by the **WARNING** and **DANGER** labels on the truck. Be especially careful when there are other people, moving or fixed objects in the working area, or when the load reduces visibility. See “Visibility” on page 1-8.
 - Never drive a truck up to anyone standing in front of an object. Ensure that people stand clear of the rear swing area before making turns.
 - **NEVER** lift, lower or transport people.
 - **NEVER** allow anyone on or under the forks (or load).
 - Under no circumstances are there to be any riders anywhere on the truck, other than the operator.
 - When driving in narrow aisles, make sure there is enough space for the truck and the load, travel at reduced speeds, and where applicable, request a helper to guide you safely through the area.
- *The operator is responsible for observing all instructions and safety regulations in their daily work routine related to the use of this truck.*
 - *Be careful at cross aisles, doorways and other locations where people may step into the path of a moving truck.*
 - *The operator must check the condition of the truck at the start of each work shift: Check the operation of the steering and brakes; The direction control lever; The shift, tilt and lift/lower controls; The condition of the battery, parking brake, horn and signaling devices, where applicable.*
 - *Make sure all access/service panels, doors and covers are installed, closed and latched tight. Do not operate the truck with panels, doors and covers removed, opened or unlatched.*
 - *Keep the truck clean and in good working order. Report any problems or damage that may risk the safety of the driver or people in the work area. Problems found must be reported and corrected. The truck must be taken out of operation until all repairs have been made and the truck has been reinspected for safety.*
 - *Always start, stop, change direction, travel and brake smoothly so as not to shift the load and/or overturn the truck.*
 - *Do not indulge in stunt driving or horseplay.*
 - *Drive carefully and slowly onto dock boards and bridge plates. Do not exceed the rated capacity of the dock boards or bridge plates and ensure dock boards or bridge plates are properly secured, either by being anchored or by being equipped with devices that will prevent slipping.*
 - *Check that dock boards have substantial contact with both the dock and the carrier, preventing them from rocking or sliding.*
 - *Maintain a safe distance from the edge of ramps, platforms and other similar working surfaces.*
 - *When leaving the operator’s compartment, the forks must be lowered to the floor, the mast must be placed in a vertical position, all controls must be in a **NEUTRAL** position and the Keyswitch must be set to the **OFF** position. Truck wheels must be blocked if the truck is parked on an incline.*

NOTE

A powered industrial truck is considered unattended whenever the operator leaves the truck and it is not in view or when the operator is 25 feet (7.6 m) or more away from the truck.

Operator Safety Training



DANGER

Every forklift operator must be trained in accordance to the rules provided by appropriate legislation. Your employer is to ensure that each powered industrial truck operator is competent to operate a powered industrial truck safely, as demonstrated by the successful completion of the relevant training course. Operating a powered industrial truck without the proper training can cause serious injury or death.

Before you start using the Bendi B3/30 AC forklift you must become familiar with its capabilities. Thoroughly read and understand the material contained in this Operator's Manual and the various machine signs (decals) found on your vehicle. Whether you are a new operator or have used forklifts for many years, read through this Operator's Manual. It provides step-by-step instructions to help you operate the Bendi B3/30 AC forklift in a safe and efficient manner.

Seat Belt

The driver's seat belt must always be worn when driving this truck. The lap part of the belt must be worn low & snug on the hips, just touching the thighs and must not be twisted.



WARNING

A twisted belt can seriously injure you. In an accident or a tip-over, the full width of the belt would not be available to take up the impact forces.

IMPORTANT

Make sure the release button on the buckle is positioned so you can unbuckle the seat belt quickly in an emergency.

Seat Safety Switch

A seat switch tells the vehicle controllers when a driver is in the operator's seat. Traction operations will shut down if the seat switch opens, signaling that a driver is not in the operator's seat.

NOTE

A two to three second delay is programmed into the seat switch to avoid nuisance shutdown and interruption of normal operations.

Parking Brake

The parking brake is located to the right of the operator's seat and is operated by hand.

Tipping Hazards and Conditions



DANGER

- Lift truck tip-over can cause serious injury or death to the operator or others in the area. Every operator must be thoroughly familiar with the tipping hazards listed in this section and must always avoid any operation of the truck which is likely to result in tipping. Also reference Chapter 3, "Understanding Stability" on page 3-10.
- All lift trucks that elevate and tilt loads are subject to the risk of tipping over, especially when accelerating or when applying the brakes abruptly.
- Transporting loads off-center also increases the risk of tip-over.

If a tip-over occurs, the operator should follow the following guidelines:

- Do not jump.
- Brace your feet firmly.
- Hold on tight.
- Lean away from the tip.

The most common causes of tip-over are listed in this section. However, the operator must use good judgment based on proper training and experience to determine turning sharpness and speed for the load being handled and the operating surface (or road) conditions.

A truck can tip longitudinally (tipping over the front or rear wheels) or laterally (tipping either to the left or right side).

Longitudinal Tipping

Longitudinal Tipping Can Occur When:

See Figure 1-3.

- the truck is overloaded.
- the mast is tilted forward excessively, with or without a load.
- the load is raised and brakes are applied while the truck is traveling forward or backward.
- the load is raised and the truck is accelerated while it is traveling forward or backward.
- the truck is driven forward down a steep incline with a load.

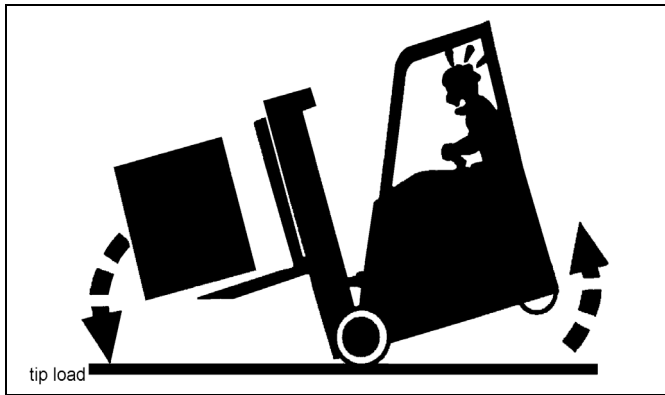

Figure 1-3 Longitudinal Tip

Lateral Tipping

Lateral Tipping Can Occur When:

See Figure 1-4.

- the truck is turned sharply while traveling rapidly in either direction, with or without a load. An unloaded truck can tip easier than a loaded truck (with the load lowered).
- the load is raised and the truck is being turned while traveling in either direction.
- the load is raised and the truck is being turned and accelerated or braked while traveling forward or backward.
- the truck is turned while traveling on a ramp or other inclined surface.
- a load heavier than the rated truck capacity is lifted.
- Tipping over in these conditions is made more likely by overloading, excessive mast tilt, or off-center positioning of the load.
- Soft tires can also reduce stability. The truck is equipped with tires of a size and hardness that will provide the necessary traction and maintain a proper shape to minimize tipping. Always replace tires with the type originally supplied by the manufacturer.

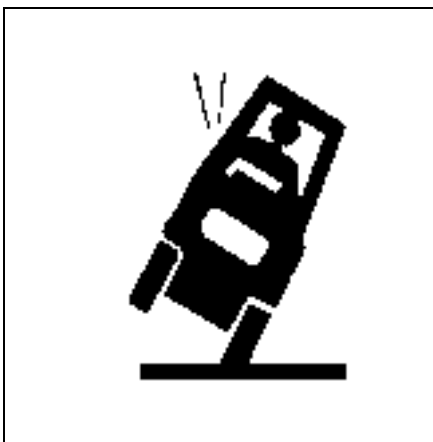

Figure 1-4 Lateral Tip

Longitudinal or Lateral Tipping

The Truck Can Be tipped Either Longitudinally or Laterally when driving:

- over objects on the floor or ground.
- off the edge of a paved surface.
- into a pothole in a paved surface.
- off the edge of a loading dock, or off the edge of a loading ramp. (It is important to avoid driving too close to the edge of a dock or ramp).

When loading or unloading a highway truck or trailer, make sure the highway truck cannot move away from a dock while loading is in process. Make sure the highway truck or trailer has its brakes applied, Keyswitch turned off and, if on an incline, has the wheels blocked.

Tipping can also occur if the truck collides with another truck or other vehicle, or if the mast runs into an overhead obstruction.

Traveling and Load Handling

- Observe all traffic regulations. Keep to the right and maintain a safe distance from the truck ahead based on speed of travel. Keep the truck under control at all times.
- Yield the right of way to other people in the area.
- Slow down and sound the horn at cross aisles and other locations where visibility is obstructed.
- Keep a clear view of the path of travel and be alert for other traffic, people and safe clearances.
- Under all travel conditions, operate the truck at a speed that permits you to bring the truck to a complete stop in a safe manner.
- Do not handle unstable loads. Use care when tilting forward or backward, stacking, returning or retrieving a load.
- Never travel with the mast tilted forward.
- Never exceed the truck's maximum lifting capacity. Refer to "Technical Specifications" on page 5-11 and the identification plate located right and front of the seat. See Figure 1-1.
- The Identification plate lists the load weights allowable for various fork heights, battery information and as well as the truck model number, serial number and other basic truck data.
- Pay particular attention when picking up a new load to ensure the load weight and height requirements are within the truck's capacity. Truck stability and handling may be adversely affected.
- Do not transport loads or other items within the operator's compartment or other areas of the truck.

SAFETY AND FAMILIARITY

- Check that the load is properly positioned on the forks before lifting.
- Spread forks as far apart as the load permits and push completely under the load. Check that forks and loads are centered. Use care when handling off-center loads.
- Travel with forks straight ahead and the mast tilted backward.
- Travel with forks or load in recommended traveling position.
- Elevate mast or load only to pick up or deposit a load. Watch out for obstructions, especially overhead. Watch all clearances.
- Tilt a loaded mast slowly.
- Do not release the lift/tilt controls suddenly when lowering loads. This may cause bouncing of the carriage, which could dump the load.
- Do not allow anyone, under any circumstances, to walk or stand under the forks or any part of the load.
- Never place any part of your body between the mast structures or any moving part of the truck.
- Do not turn when traveling on ramps. When descending ramps, travel forward (forks facing downhill) when empty, travel backward (forks facing uphill) when carrying a load.
- Use care even when traveling without a load. Avoid high speeds, sharp turns and abrupt stops.

Speed

Travel speed must be chosen according to the situation, such as, the load being handled, road surface conditions, visibility, people working in the area, moving and fixed objects in the area, and cross aisles.

Always operate the truck at a speed that will permit it to be brought to a stop in a safe manner.



WARNING

Careless driving, including, fast starts or abrupt braking, excessive speed at turns or through cross aisles, sudden stops, or hard turns at high speeds can all lead to serious personal injury and damage to the truck or load. Always drive with safety as your number one goal.

Visibility

Where visibility is restricted, travel at very slow speed and use the horn frequently.

Always ask for a helper ("Banksman") to guide you safely through the area when visibility is restricted.

Battery Safety

The truck battery contains concentrated sulfuric acid which can cause severe chemical burns.

When the battery is charging, it releases hydrogen, a colorless, odorless and highly explosive gas which can be ignited by a spark.

Eliminate all sparks or flames from the charging area.

Shorting battery terminals can release enormous amounts of energy, causing sparks or flame, or heating nearby components to dangerous temperatures.

The Bendi B3/30 AC Model truck is standard with a rollout battery tray. See Figure 1-5.

The battery restraint must be inserted and securely locked in place whenever the battery is installed.

A rollout safety switch will not allow the truck to move unless the restraint is in place.

The battery is very heavy, and if restraints are not replaced after maintenance, the battery could slide out of the truck, causing electrical shorts or spilling acid - or it could cause the truck to tip over.

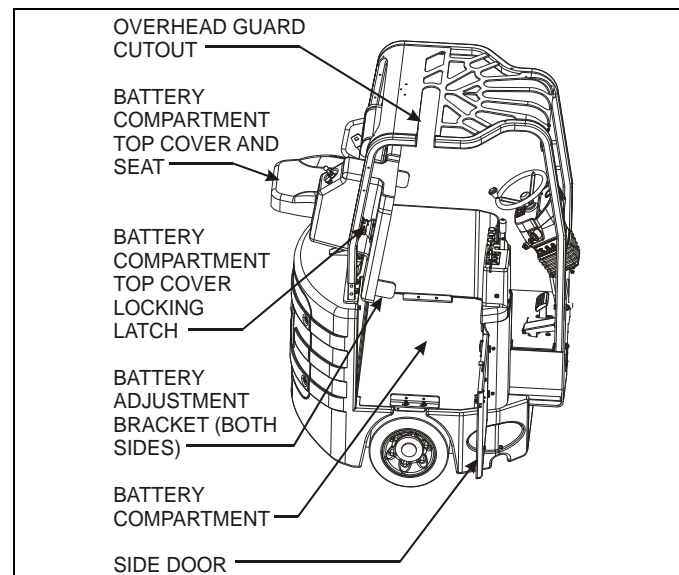

Figure 1-5: Battery Rollout Tray with Open Covers

The battery is also used as a counterweight. A different size or weight battery could cause the truck to become unstable and tip. Use a battery that meets the weight and size specifications shown on the capacity plate near the operator's compartment.

Battery Safety Rules:



CAUTION

- Wear protective clothing, rubber apron, boots gloves and full-face shield when performing any maintenance on the B3/30 AC battery.
- DO NOT allow electrolyte to come in contact with eyes, skin, clothing or floor. If electrolyte contacts eyes, flush immediately with clean water. OBTAIN MEDICAL ATTENTION IMMEDIATELY! Should electrolyte be spilled on skin, rinse promptly with clean water and soap. A baking soda solution (one pound to one gallon of water) will neutralize acid spilled on clothing, floor or other surfaces. Apply solution until bubbling stops and rinse with clean water.
- Keep battery vent plugs firmly in place at all times, except when adding water or taking hydrometer readings.
- DO NOT bring any type of flame or spark near the battery.
- DO NOT place any electrically conductive tool on the battery that could cause a spark. Gas formed while the battery is charging is highly explosive. This gas remains in the cells long after charging is complete.
- Keep the battery clean. Foreign matter in the electrolyte will result in poor battery performance.
- Follow the battery manufacturer's instructions concerning maintenance and repair.

Battery Care and Charging



CAUTION

- Only qualified and experienced personnel should perform maintenance and repair on batteries.
- Make certain the charger being used matches the voltage and amperage of the truck battery. This voltage is listed on the truck serial plate. See Figure 1-1.
- Before connecting or disconnecting batteries to the charger, make sure the charger is OFF. Attempts made to do this while the charger is ON could result in serious injury to the operator and damage could occur to the charger, with sparks or electrical spikes.
- Keep sparks or open flame away from the battery or the charging area.
BATTERY FUMES ARE EXPLOSIVE!
- NEVER smoke or have an open flame near the battery. Gas formed during charging is explosive and can cause injury. Consult the charger manufacturer's manual covering your charger for operation and maintenance.
- The battery must meet size, weight and voltage requirements of the truck.

Battery Removal and Installation



CAUTION

Battery Removal:

- When removing the battery move the truck to an area intended for battery care, on a level floor.
- Turn the Keyswitch to the OFF position and remove the key.
- Disconnect battery and lock out the truck as described in the Lock Out/Tag Out section described on page 1-2.
- Never remove the battery partially from the truck without a roller stand in place.
- Lower load completely. If battery is removed with load raised, use hoist attached to mast to protect against tip over.
- DO NOT allow any metallic object to come in contact with the top of the battery. This may cause a short circuit when removing or transporting the battery. Use an insulator (such as plywood) to cover the top of the battery during removal.



CAUTION

Battery Installation:

- When installing the battery move the truck to an area intended for battery care.
- The load forks must be all the way down to the floor.
- Turn Keyswitch to the OFF position and remove the key to a secure place.

Good Battery Care Requirements:

- Add approved water only - never add acid.
- Keep electrolyte levels proper.
- Keep battery top clean and dry.
- Keep flame and metal away from battery top.
- Keep vent caps tightened.
- Cool before charging/operating battery above 115°F.
- Use only approved correct voltage/current charger.
- Keep battery cover open while charging.
- If in doubt, call your local Landoll service technician.

In Case of a Fire!



WARNING

- Fumes and smoke from any fire may be dangerous and can be deadly.
- All fires should be handled by professionals. Be familiar with and follow your company's policy in regards to extinguishing a fire. Know ahead of time where the emergency phone numbers are located.

Service and Repair Safety

When it becomes necessary to do any service repair or maintenance to the truck, it is important to first review the following safety guidelines.



WARNING

You could be injured and the truck could be damaged if you try to do service work without proper training or equipment.

1. Be sure you have sufficient knowledge, experience, the proper tools and replacement parts before you attempt any truck maintenance.

2. Be sure to use proper nuts, bolts and other fasteners. Many are specifically rated; that is, SAE Grade 5, SAE Grade 8, ISO Prop Class 8.8, etc., and must be replaced with the identical type. It is recommended to use only Landoll authorized replacement parts.



WARNING

If you use the wrong nuts, bolts or other fasteners, parts can later break or loosen. Serious injury could occur.

3. Whenever possible, return the truck to a service area having sufficient lighting, work space and an assortment of tools needed to complete the service.
4. Set the Keyswitch to OFF and set the direction control lever to NEUTRAL.
5. Disconnect the battery and perform the Lock Out/Tag Out procedure.
6. Never place a tool or any metal object on top of the battery where it could possibly touch battery terminals, causing a short or serious electrical shock.
7. Make sure all lifting devices and supports, such as, a support or jack stand, are capable of handling the weight of the load being applied.



WARNING

- To be certain the truck will not move, place wedges (or blocks of wood) at the front and back of the tires.
- If you are servicing the brakes or tires, place the blocks at the front and rear of the tires farthest away from the one being serviced. (That would be the tire on the opposite side of the truck and at the opposite end.)

8. Always place an appropriate support stand under the truck if it is being lifted, then lower the truck on to the stand, having both the lifting device and stand supporting the weight of the truck.



DANGER

Getting under a truck when it is lifted or jacked is dangerous and could cause serious injury or death. Never go under a truck that is supported by only a jack.

9. Fully open the required truck covers and be sure they are braced to prevent accidental closing.

Receiving and Inspection

This Chapter of your Bendi B3/30 AC Forklift Operator's Manual covers all of the procedures and information you will need to successfully receive your truck and get it ready for operation. If needed Storage, Towing and Shipping information for the forklift is also provided, Before shipping from the Landoll Corporation, each Bendi B3/30 AC truck is inspected to make sure the truck you receive is in impeccable condition and equipped per your order. Additionally, we recommend that you:

- Inspect the truck for any signs of physical damage during shipment. Note any apparent damage on the bill of lading and request the delivery agent sign it.
- Report any damage to your distributor and the shipping company.
- Verify that the truck configuration and options match your purchase order. Report any discrepancies to your distributor.

Items Furnished With Your Truck

Bendi B3/30 AC trucks are shipped from the factory with one copy each of the Operator's Manual, Parts Manual, a battery disconnect handle and a set of ignition keys attached to the steering column.

Items Required

When the truck is received, a battery approved for use in the truck must be installed.

The battery must be replenished from a battery charger at certain intervals. See "Battery" on page 5-3.

No additional items are required to operate the truck.

Tools and Test Equipment

In general, no special tools or test equipment beyond those found in a well-equipped service center are required for general maintenance by the operator. However, custom bearing, seal installation tools and a calibrated torque wrench are helpful when performing more involved service.

Preparing the Truck

1. Check the hydraulic oil level. See "Hydraulic Oil" on page 5-7.
2. Check the fluid level in the brake master cylinder reservoir. See "Check the Brake Fluid Level" on page 5-6.
3. Check the condition of the battery. See "Battery" on page 5-3.

Inspecting the Truck

Before releasing the truck for use, prepare a log book or log sheet for each truck at your site. List all services, repairs and adjustments performed, as well as equipment or operation problems, along with when they are repaired (hour meter reading and date the service was performed). Permanent logs serve as a checklist to show maintenance and repair history, and to record whether faults have been corrected. See "Daily Checklist" on page 5-1.

Visual Inspection

Many problems can be spotted by a simple visual inspection of the truck; such as, oil leaks, damaged tires, cracks in welds or forks, damaged covers, etc.

It is possible for dirt, grease, oil and debris to mask some problems. If possible, the truck should be cleaned on a regular basis. If possible, high-pressure washing should be avoided.

To remove stubborn grease accumulations, a grease dissolving solvent may be needed. Make sure the solvent is not harmful to painted surfaces.

NOTE

Chapter 5, "Daily Checklist" on page 5-1, contains an Operator's Daily Checklist, which should be used as a guideline when inspecting the truck.



DANGER

Grease solvents are often toxic and may be flammable. Use only in accordance with the solvent manufacturer's recommendations supplied with the solvent. For example, use only in a well-ventilated area and do not breathe vapors. Wear protective goggles, aprons, and gloves. Avoid contact with skin, eyes and clothes. Keep away from heat and flame. Do not smoke when using solvents or in the area where solvents are stored.

Failure to observe these precautions may result in death or injury.

Lubricate all grease fittings and metal-to-metal surfaces located outside the truck. Refer to "Rotation Bearing Grease Points" on page 5-9 and "Recommended Lubricants" on page 5-10 for lubrication information.

General Walk Around

With the truck Keyswitch set to OFF and the direction control switch set to NEUTRAL, perform a walk-around inspection. Always pay strict attention to all CAUTION, WARNING, and DANGER decals affixed to the truck and thoroughly read the SAFETY chapter of this manual. Check for obvious damage that would require more detailed inspection. If you notice or suspect a problem, immediately report it to your supervisor, record it in the truck log book, and have it checked and/or repaired before releasing the truck for use.

General system checks should include the following:

Battery Restraint

Check that the battery restraint is in place and correctly positioned whenever a battery is installed in the truck. See Figure 2-1.

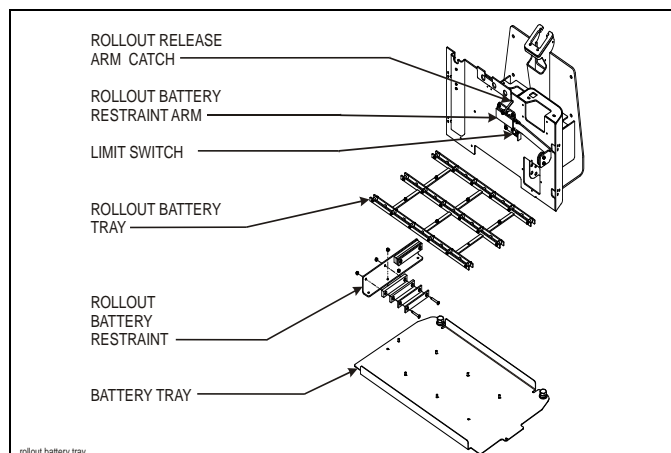

Figure 2-1 Battery Restraint

Service Brakes

With the Keyswitch set to ON, drive forward slowly and then steadily apply the brake pedal. The truck should stop smoothly without noticeable side pull or vibration. Check the operation of the brake pedal for smooth, firm, unobstructed movement when pressed and released. Problems with the brake system must be repaired immediately by service. Do not use the truck.

Driver's Seat

- Check the seat covering and seat belt for rips or cuts. Check that the seat belt is firmly attached and that the buckle is not damaged.
- Check that the seat belt works properly.

The driver's seat switch system includes an interlock that can shut down the drive and power steering motors and disable the direction control (resets to NEUTRAL) bringing the truck to a smooth STOP.

The mast functions remain operable.

To check the seat switch interlock:

1. Sit in the driver's seat and set the Keyswitch to ON.
2. Set the direction control lever to FORWARD and slowly increase motor speed until the truck begins to move.
3. Lift your foot from the accelerator pedal and let the truck come to a complete stop.
4. Lift yourself from the seat far enough to release the seat switch.
5. Press the accelerator and notice you must return the direction switch to neutral and then back to forward (or backward) for motion control to return. If this operation is not observed, immediately report this to your supervisor, record it in the truck log book. Have this operation checked and repaired before releasing the truck to use.

Fasteners

Check for damaged, loose or missing screws, bolts and nuts. Tighten and/or have service replace as needed.

Horn, Lights, etc.

Check lights for proper on/off operation and for blown bulbs. Check that the horn sounds when pressed. Repair and/or replace as needed.

Hydraulic Lines and Loose Fittings

Check underneath the truck for evidence of fluid leaks. Look for hydraulic hose wear, damage and leaks. Make sure clamps and fittings are tight. If leaks are found, have service repair all leaks immediately and check the hydraulic fluid level. Do not use the truck.

Hydraulic Oil Level

Check the oil level weekly. Low oil can cause operational problems. See "Hydraulic Oil" on page 5-7.

Dash Display

Inspect the dash display for errors, faults and damage to ensure normal operation.

Mast Operation

With the Keyswitch turned ON, raise the mast. Check that the primary cylinder extends fully and that the lift carriage rises to the top of the inner rails before the secondary cylinders begin to move.



WARNING

Never place your head, hands, arms or feet in the mast area. Make sure there is sufficient room above to raise the mast safely.

- When the lift carriage reaches the top of the inner rails, the secondary cylinders and middle rails begin lifting. Check to make sure the rails travel smoothly and that there is no chatter or visible binding.
- With the mast fully extended, begin lowering the mast. The secondary cylinders and middle rails fully lower first, followed by the primary cylinder and the lift carriage. Check for smooth travel with no chattering or visible binding.
- If there is noticeable chatter or binding, immediately notify your supervisor or service personnel.
- DO NOT attempt to repair the mast or operate the truck until the problem is corrected.



DANGER

If the mast does not raise or lower properly, or shows signs of binding, it may release or stop suddenly. Sudden motion may allow the load or carriage to drop, this could result in death or serious injury to the operator or nearby persons and/or damage the load.

Overhead Guard

Check the overhead guard and make sure that it is firmly attached to the truck and that all fasteners are secured. The overhead guard is adjustable to accommodate various drivers' and operating restrictions (low ceilings, door openings, etc).

Parking Brake

The parking brake system is controlled by the a lever located to the right of the seat.

To check the park brake:

- Pull the parking brake toward you to set it. Push it away from you to release it. You cannot drive your Bendi forklift while the brake is engaged. The truck will not respond to the accelerator pedal unless the lever is pushed forward all the way.
- If the park brake does not stop(hold) the forklift, the truck must be removed from operation until the problem has been identified and corrected.

Rust Or Corrosion

Check the truck frame, side and floor panels for rust and corrosion. Clean rusty or corroded areas and repaint, if applicable. Apply a thin coat of oil to any bare metal surface.

Safety Decals, Data Plates, etc.

Check for damage and missing decals or data plate. Check that the decals are legible. Clean and/or replace as needed.

Static Discharge Strap

Make sure the static discharge strap is dragging (touching) the ground. The strap is located at the bottom of the truck, near the front wheel. See Figure 2-2.



Figure 2-2 Static Discharge Strap

Tires and Wheels

Check tires for cuts or chunking, oil slicks, embedded foreign material or excessive wear. Check wheels for missing lug nuts. Repair and/or have service replace immediately. Do not use the truck.

Welds, Cracked or Broken

Check for damage and reliability. Clean and repair immediately. Do not use the truck.

Wires or Connectors

Look for damaged, cracked or broken insulation, bare wires showing loose or broken connectors. If electrical problems are found, have service make repairs immediately. Do not use the truck.

Fire Extinguisher Option

If your truck includes a fire extinguisher it should be inspected at least monthly, or more frequently if circumstances dictate. The extinguisher should be checked to see that:

- it is not damaged.
- the discharge outlet is not blocked.
- it is fully charged and the seal is not broken.
- the instruction pamphlet is clearly visible

IMPORTANT

Dry-powder extinguishers are shipped fully charged. Do not experiment with your extinguisher since even a small amount of discharge could cause it to slowly lose the rest of its pressure, rendering the extinguisher useless.

Storage, Towing or Shipping

Truck Storage

If the truck is to be stored for a length of time:

- The truck should be stored indoors within a temperature range of +35° F (2° C) to +115° F (46° C) and a relative humidity of 90%, preferably less.
- The truck should be raised with the tires at least 2" (51 mm) off the floor and the frame set on large wooden blocks. Hard polyurethane tires, over long periods of time can develop flat spots that may not return to normal when the truck is returned to service, rendering the tires defective.
- If the truck must be stored outside, it must be covered securely with a tarpaulin. Continued exposure to sunlight will cause deterioration of rubber tires, gaskets and hoses, as well as vinyl seat coverings, etc.
- For long-term storage, the truck battery should be removed and stored where it can be periodically checked and recharged every three months.
- In general, batteries that are fully charged with the electrolyte at the proper level may be stored for up to one year. Batteries should be stored in a cool, dry, well-ventilated area, covered with a non-conductive material to protect them from dirt, moisture, etc.

IMPORTANT

Do not drape flexible plastic sheeting over batteries as it might trap explosive gases underneath. For batteries stored for more than one year consult the manufacturer. Consult the battery documentation or the manufacturer for storage method and routine inspection required during the temporary storage interval.

Towing the Truck

If the truck breaks down and cannot be repaired at that location, it may be towed by attaching a suitable hook and chain to the tow pin in the rear of the truck. See Figure 2-3. Remember with no power to the truck being towed, steering will be difficult. Carefully and slowly tow the truck backwards to your service repair area.

An operator must be on the towed truck, wearing a seat belt.



WARNING

- **Make sure the towing equipment is capable of handling the weight of the truck being towed.**
- **Never lift a truck using straps, chains or hoists of any type. Never connect lifting equipment to the operator's compartment overhead guards.**
- **Never use the truck to tow materials.**
- **Never tow a truck that is carrying a load.**
- **Never connect towing equipment to the mast.**
- **For better traction, partially load the truck doing the towing.**



Figure 2-3: Tow Pin Used for Towing

To Ship the Truck

1. Set the mast to its forward position (straight ahead).
2. Back the truck onto its carrier so that the forks are pointed away from the forward direction of motion.
3. Set the mast to its forward (level) position and lower the forks to the bottom of the mast. Align the mast indicator pointer located on each side of the mast to a level position, as viewed from the front of the truck.
4. Set wedges against the front and rear tires and fasten them to the floor of the carrier. If the carrier is equipped with rings or receptacles for chains or cable rope, support the truck as firmly as possible.

IMPORTANT

Do not run chain or wire directly touching the battery cover or any other finished metal surface. Use padding as necessary to protect the truck finish from chains or cables.

Understanding the Bendi B3/30 AC Forklift

This Chapter of your Bendi B3/30 AC Forklift Operator's Manual contains information that will familiarize you with the basic forklift design and operating principles.

Vehicle Description

The Bendi B3/30 AC is a narrow aisle type lift truck. The principle operation of this forklift truck is that the weight of the load, which is carried on the forks in front of the load wheel, is offset by the combined weight of the heavy truck chassis and its battery unit. To maintain a safe counterbalance limit, a ballast weight is also mounted to the rear of the truck chassis.

The Bendi B3/30 AC forklift is available in a maximum 3,000 lb. capacity. The front end can be pivoted 200 degrees. This permits the vehicle to act as a conventional as well as a narrow aisle forklift.

The Bendi B3/30 AC truck also offers:

- Three-wheel configuration - single front drive/load wheel ; dual rear braking wheels.
- Interactive LCD Status Monitor; Battery Status(BDI) with lift interrupt, Hourmeter with Service Monitor and Diagnostic Code Display.
- Hydraulic lever operation for load functions - utilizing a three-function hydraulic control valve.
- 48 volt DC battery with emergency disconnect switch, latching battery cover with drive interlock, plus side access compartment utilizing slide strips or optional rollers.
- Triplex high visibility mast configurations.
- Lift capacity is a maximum of 3,000 lbs./1,361kgs. at 24"/600 mm load center.
- Ergonomically designed operator compartment includes sit-down operator position, adjustable driver's seat, tilt/telescoping steering wheel, hand lever direction and mast controls, arm rest and operator supply tray.
- Safety interlocks - Keyswitch activation and operator seat safety switch, plus an electrical lockout requiring the direction control lever to be in the neutral, or center position, before power can be restored.

Machine model, serial and option numbers (where applicable) are stamped on the identification (capacity) nameplate affixed near the front operator's cab. See Figure 3-1.

IMPORTANT

- **Bendi B3/30 AC truck operators and service personnel must familiarize themselves with this manual and the Bendi B3/30 AC truck to provide safe and efficient operation. Practice runs in a controlled and safe area, away from obstacles and other personnel, are recommended. Unauthorized driving by untrained or unskilled personnel must be strictly prohibited.**
- **All safety notices in this manual and the safety regulations, or standards valid in your local area, must be strictly enforced.**



Figure 3-1: Identification/Capacity Plate Location

Truck Identification

The following illustration will help you locate components on your Bendi B3/30 AC forklift (See Figure 3-2.)

1. Forks
2. Load Backrest
3. Mast
4. Rear Braking Wheels
5. Steer/Drive Wheel
6. Overhead Guard
7. Steering Column
8. Keyswitch
9. Emergency Interrupt Switch
10. Dash Display
11. Battery Compartment
12. Identification Plate
13. Frame ID Number Location - inside on rear surface
14. Mast ID Number Location

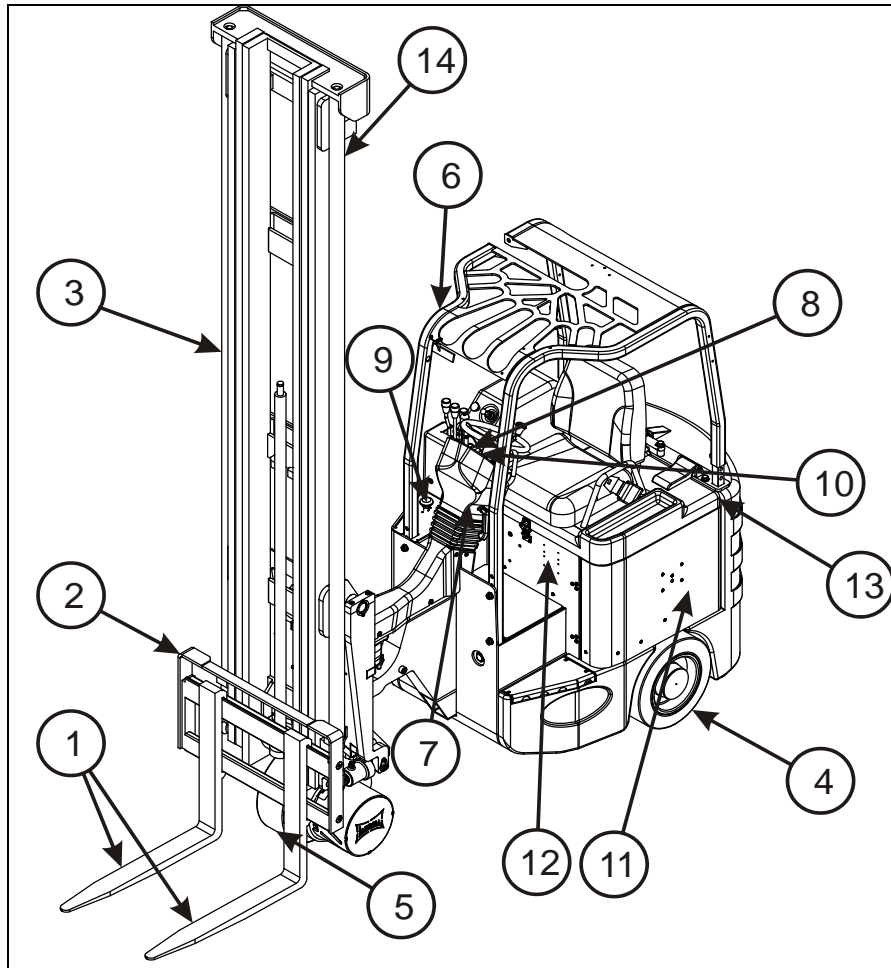

Figure 3-2: Component Locations

Identification Plate

The identification plate, which lists the rated capacity, serial number and other vehicle characteristics. See Figure 3-3. It is located to the right of the seat. See Figure 3-1.

The following list explains items that appear on the identification plate:

- **Model** - The model number of your Bendi B3/30 AC forklift appears here.
- **Serial Number** - The serial number of your Bendi B3/30 AC forklift appears here.
- **Mast Number** - The serial number of the mast appears here.
- **Rated capacity** - The rated capacity is stated with the forks at various fork heights. As you lift the load higher, the rated capacity of the forklift decreases.
- **Lift height** - This is the fork height stated in inches and centimeters. This is the distance between the ground and the top edge of the forks.
- **Weight** - The rated capacity of the forklift at various fork heights. Rated capacity stated in pounds and kilograms.

- **Unladen Mass Without Battery** - The actual weight of your Bendi B3/30 AC forklift as built without the battery installed; stated in pounds and kilograms.
- **Minimum Service Weight of Battery** - The battery must weigh at least this much for your Bendi B3/30 AC forklift to operate properly; stated in pounds and kilograms.
- **Maximum Service Weight of Battery** - The battery must not exceed the weight stated here for the Bendi B3/30 AC forklift to operate properly; stated in pounds and kilograms.
- **Maximum Unladen Mass** - This is the Unladen Mass Without Battery added to the Maximum Service Weight of Battery; stated in pounds and kilograms.
- **Battery Type** - This is the rating for the battery itself as designated by Underwriter's Laboratory (UL), Standard 583. This describes the construction of the battery and battery enclosure with respect to the risk of fire, electric shock and explosion.
- **Truck Type** - This designation assigned by the Underwriter's Laboratory (UL), Standard 583, describes the overall design of the electrical components on the truck. Type "E" offers safeguards against an inherent risk of fire and electrical shock and Types "ES and EE" adds additional safeguards to prevent emission of hazardous sparks and limits surface temperatures.
- **Nominal Voltage** - Nominal voltage indicates that the truck uses a 48 VDC battery.
- **Horizontal Load Center** - The horizontal load center is equal to one-half the length of the rated load when the weight is evenly distributed.
- **Vertical Load Center** - The vertical load center is equal to one-half the height of the rated load when the weight is evenly distributed.

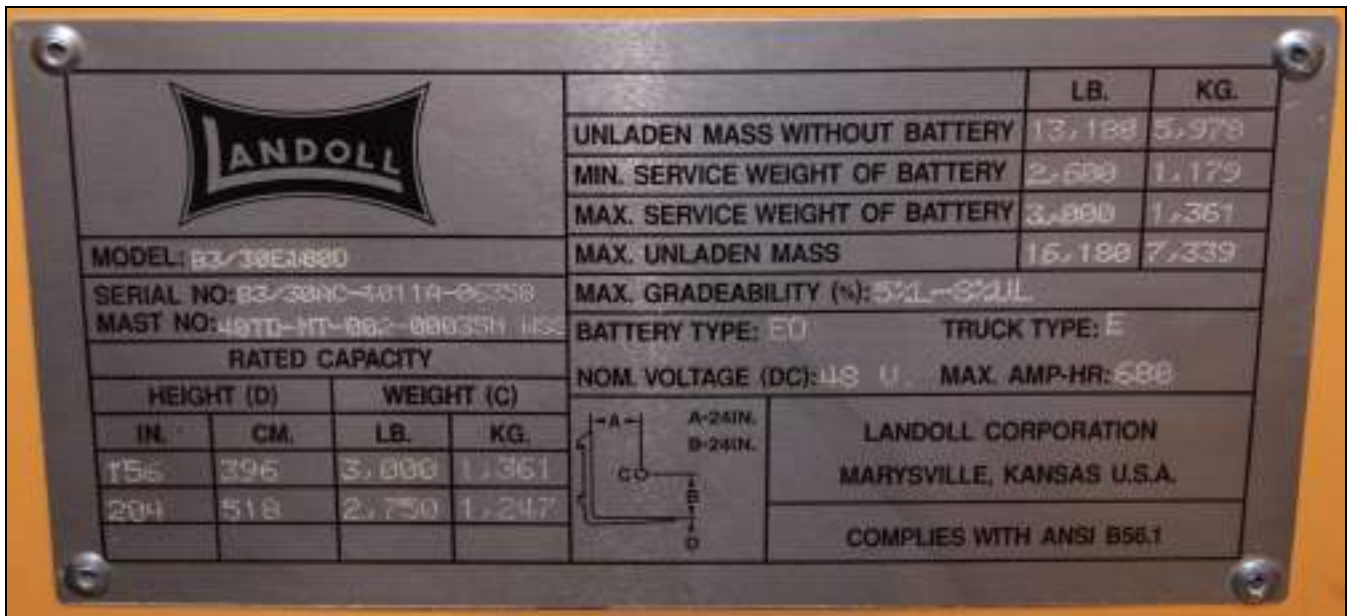

Figure 3-3: Identification (Capacity) Plate



CAUTION

The frame number is also located on the left side of the frame. See Figure 3-2. You can compare the frame number listed on the identification plate with the frame number on the frame of the truck before you operate the truck.



CAUTION

The mast serial number is also located on the inside of the mast. See Figure 3-2. You must compare the mast serial number listed on the identification plate with the mast serial number on the mast of the truck before you operate the truck.

Bendi B3/30 AC Serial Number Code

The following information will help decode the forklift serial number:

B3/aa/wwtt-yymms-xxxxx

Table 3-1: Serial Number Code

aa	= 30 for 3,000 lb rated capacity truck
ww	= 44 for 44" frame width
tt	= type i.e. AC
yy	= last digit of year of manufacture (ex. "09" means 2009, "10" means 2010)
mm	= month of manufacture
s	= component series; such as "A"
xxxxx	= frame number

Understanding Truck Rated Capacity



DANGER

Never load a lift truck beyond its rated capacity. Loading beyond rated capacities can cause axles to break, the truck to tip over, load to fall, serious injury or death. See identification (capacity) plate for rated capacity and load center information.

Before you begin to operate the Bendi B3/30 AC forklift, you need to know some basic operation principles. One of the most important facts about the Bendi B3/30 AC forklift is its rated capacity (how much weight it can safely lift) and how to properly carry a load to maintain stability. This weight is listed as the rated capacity on the identification plate. See Figure 3-3.

The rated capacity varies for each load depending on:

- Where the horizontal and vertical load centers are.
- The height you plan to lift the load.
- Attachments used.

Truck Overview

Before operating the Bendi B3/30 AC Forklift, familiarize yourself with the basic parts of the truck. The following sections describe the different components that make up the Bendi B3/30 AC Forklift.

Frame

The frame consists of 10 ga. to 4" thick (9.525 mm to 25.4 mm) steel panels welded together to form the backbone of the truck (basic truck shape). A number of thick rectangular steel shapes (counterweights) are welded within the frame to counterbalance the truck against the weight of its load. The rear wall of the truck also includes a thick steel plate to add additional counterbalance.

NOTE

The size and weight of the battery is also used as a counterbalance.

Steering

The steering system shares oil with the main hydraulic system. A single pump that is controlled through the AC pump motor controller generates steering flow and pressure. Oil is diverted from the main control valve to the steering control unit based on demand from the operator. As the steering wheel is turned, the on-demand oil is sent to the steering motor at the front of the lift truck causing the truck to turn.

Brake System

The rear wheels are equipped with hydraulically-actuated dry drum brakes. The brake pedal activates a master cylinder to apply hydraulic pressure to brake cylinders, forcing the brake pads to grip the drum.

The system is a dedicated system using standard DOT #3 brake fluid and non-asbestos brake shoes.

Electrical System

Traction

A single AC traction controller, rated at 350 amps, is used to control truck speed, by way of the front drive motor. The truck speed is limited by the mode switch on the dash and the angle of the front end relative to the body of the truck. As the truck is turned towards 100 degrees the maximum truck speed is limited.

Keyswitch

The Keyswitch switches electrical power to the truck ON and OFF. See Figure .

Safety Interlock

Both a key lock switch (Keyswitch) and an operator's seat switch must be engaged before the truck can move. The seat switch is activated when the operator is seated in the driver's seat. See "Seat Safety Switch" on page 1-6 for additional information.

Battery

A 48 volt lead-acid battery provides drive power, as well as power for the hydraulic system, power for lights and other auxiliary equipment.

For maintenance and/or emergencies, an emergency stop button (red) is provided on the front right-hand side of the driver's compartment. See Figure 3-2. For maintenance the driver's seat compartment cover, a hinged side cover, overhead guard cutout and slide strips allow easy battery removal from the right side. As an option, rollers can be provided for additional battery maneuverability.

Battery Rollout Tray

For maintenance, a rollout battery tray(optional) allows for easy battery removal from the right side of the truck.

The rollout battery tray assembly includes: See Figure 3-4.

- Roller tray.
- Side restraint bracket, with spacer/shims as required
- Adjustable restraint arm and required spacers/shims.
- Limit switch for restraint arm.

The battery rollout assembly reduces downtime when changing batteries by offering easy battery servicing.

With the battery rollout restraint arm installed and locked, the limit switch is actuated to allow complete truck operation. Spacers/shims are provided to secure the battery within the compartment.

Releasing the rollout restraint arm handle and removing the arm for battery removal, releases the limit switch to shut down the truck. All operations are disabled.

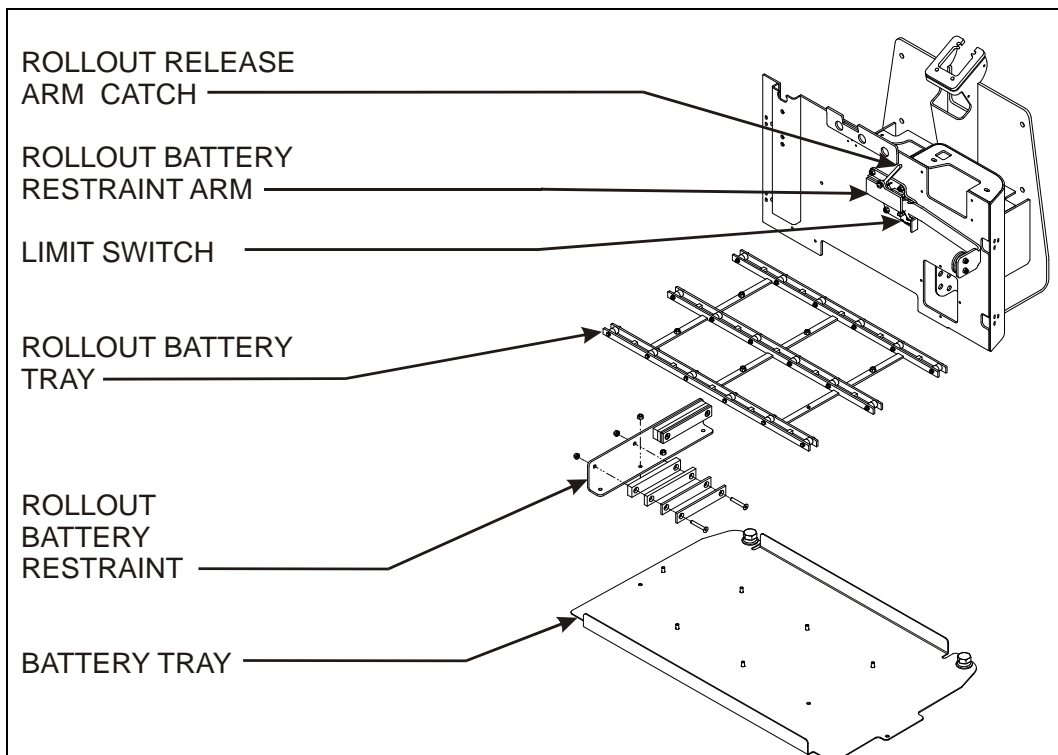

Figure 3-4: Rollout Battery Tray

Emergency Interrupt

The emergency interrupt is located to the front right-hand side of the driver's compartment. See Figure 3-2.

Activate the emergency interrupt by pushing the big red button down to disconnect all power from the truck. The truck will come to an abrupt stop. To reset pull button up.

Use this button:

- in case of fire, smoke/overheating or an accident.
- if a person comes between the truck and an object.
- in case of a short circuit or other electrical malfunction. Example: Pump motor is running continuously.

Hydraulic System

The system uses a single pump to generate pressure and flow to meet the needs of both the power steering system and the mast system. Only the amount of oil needed by the steering system is provided to the steering system. The amount of oil diverted to the steering system is based on operator input, allowing the excess oil to return to tank at a lower pressure, reducing the demands on the battery. The hydraulic pump motor is speed controlled to provide adequate steering response and is enabled through the selection of truck direction.

IMPORTANT

Do not turn the steering wheel to its full rotation and hold it there for long periods of time. Unnecessary pressure will build up and apply excessive pressure to the power steering components, causing excessive noise, heat and perhaps damage.

Additional pump flow is provided linearly with the actuation of the lift function.

Actuation of both the tilt and side shift functions provide step increases in pump flow to meet the demands of the function, while ensuring adequate flow to the steering system.

System cooling uses convection and conduction of heat from the reservoir, hydraulic tubing and cylinders to maintain a safe operating temperature below 175° F (97.22° C).

A steel mesh suction filter, within the hydraulic reservoir, plus an easily accessible return line filter (10 micron rating) with a contamination level of ISO 2943 or better, is used for oil filtration.

The following sections briefly describe how each of the hydraulic functions operate:

Mast Controls

Mast positioning is achieved by operating the proportional control valve via the mast control lever. Hydraulic pressure is provided by a vane pump driven by a single A.C. electric motor. Mast movements may be operated individually or together, however, when operated together, the speed of operation is somewhat limited.

Mast Lift

The mast lift circuit provides the means for lifting and lowering the mast and fork assembly. The mast lift consists of three hydraulic cylinders - one primary and two secondary, a velocity fuse and a flow regulator.

Mast Tilt

The mast tilt circuit provides the means for tilting the mast and fork assembly forward and back. Tilting movements are accomplished through the use of two hydraulic double-acting cylinders mounted to the bottom of the mast pivot arm.

Mast Side Shift

The side shift circuit provides the means for moving the mast laterally (left-to-right). Side shift movements are accomplished using two hydraulic cylinders that push the crosshead side to side, mounted on nylatron slides.

Mast Lift Assemblies

Various mast assembly configurations (triplex or quad) can be applied to the B3/30 AC Model trucks to provide both collapsed and extended heights suitable for all customer requirements. The lifting capacity of the mast also varies depending on the truck and its application. Load capacities are determined at 24" (609.6 mm) centers, centered on the mast and include all attachments on the carriage. The B3/30 AC specifications list the dimensions of standard masts available for these trucks. See "Technical Specifications" on page 5-10.

Also check the identification plate in the operator's compartment for the maximum lifting capabilities, based on the particular truck and mast combination. See Figure 3-3.

The trucks are counterweighted to compensate for all positions up to the maximum allowed load.

Masts are engineered to distribute thrust loads evenly between the rollers and rails. Masts move as a unit, providing maximum strength and endurance for the rated load and consist of up to four pairs of channels or rails (steel beams) rolling one within the other on steel rollers. The outer rails provide guidance and support for the middle rails, which in turn guide and support the inner rails. The truck forks are mounted on a carriage assembly that runs on rollers within the inner rails. See Figure 3-5.

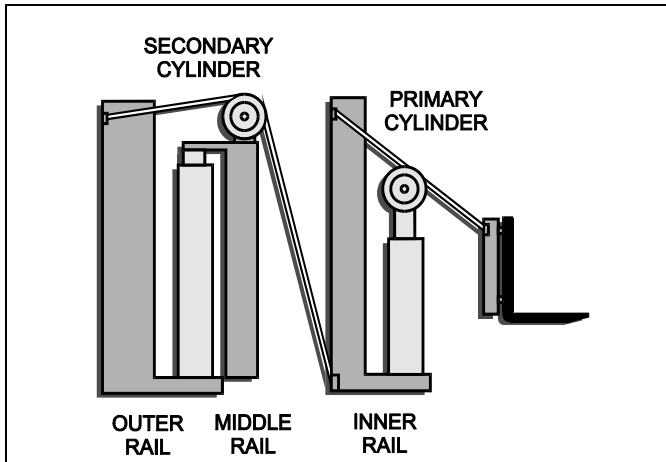

Figure 3-5 Mast in Collapsed Position

On a triplex mast, a primary cylinder is supported by the inner rails and hydraulically controlled. As the primary cylinder rod extends, a sheave and chain assembly lift the fork/carriage upward at twice the distance covered by the cylinder rod. This first stage of carriage lift is called free lift. It is the distance of lift available without increasing the overall height of the mast assembly. See Figure 3-6.

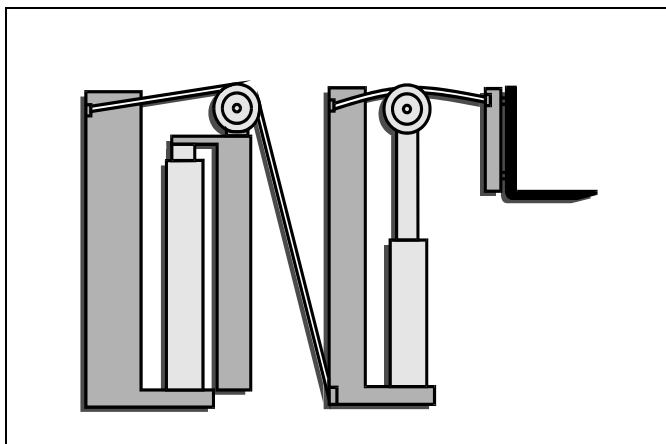

Figure 3-6 Mast in Free Lift Position

A secondary cylinder, attached to the outer rails, lifts the middle and inner rails progressively via chains, rollers and sheaves. The inner rails are raised at twice the rate of extension of the secondary cylinder piston. This upward lift continues until the secondary cylinders are fully extended. See Figure 3-7.

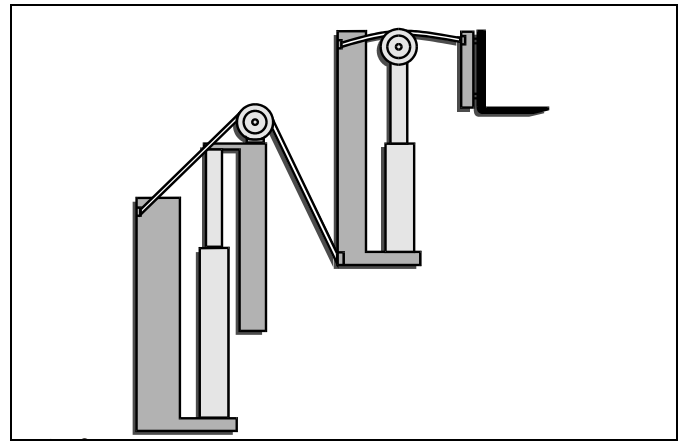

Figure 3-7 Mast Fully Extended

The hydraulic fluid used to lift the primary cylinder is applied sequentially to the secondary cylinder. When the primary cylinder reaches full extension, the secondary cylinder begins to extend. The differences in weights being supported by the cylinders, along with the differences in cylinder diameters, ensure that the primary cylinder will be fully extended before the secondary cylinder can begin to move. Consequently, when the mast is raised, it moves through two phases:

- Free lift, in which only the carriage assembly moves, up to the maximum height allowed by the inner rail. See Figure 3-5.
- Rail extension, in which both the middle and inner rail moves, carrying the carriage upward. See Figure 3-6.

Downward movement of the mast is accomplished by releasing the hydraulic fluid from the cylinders back into the reservoir.

The weight of the rails (& load) and carriage provides enough pressure to force the fluid from the cylinders. When the secondary cylinder piston is fully contracted, the primary cylinder begins to collapse, forcing its fluid back to the reservoir.

The mast is supported by trunnions, which allow it to tilt fore and aft. Two short hydraulic cylinders are mounted between the mast and the pivot arm to control the amount of tilt. A mast indicator gauge (pointer) is located on the both sides of the mast to indicate when the carriage and forks are perfectly level with the floor.

As an option, trucks may be equipped with quad masts which utilize four sets of rails, referred to as Outer, Outer Intermediate, Middle, and Inner rails, respectively. See Figure 3-8.

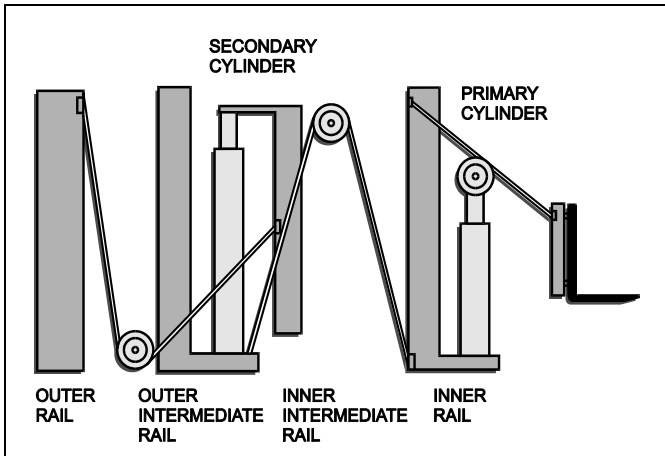

Figure 3-8 Quadplex Mast in Collapsed Position

The primary cylinder and carriage operate the same as a triplex (three-rail) mast. When the secondary cylinders extend, they lift the middle rails. Through an intricate system of chains and sheaves, the rising middle rails pull up the outer intermediate rails at half the middle rail speed, and push up the inner rails at twice the middle rail speed.

Driver Controls

Driving controls for the Bendi B3/30 AC truck include a foot brake pedal and an accelerator foot pedal for speed control, tilting/telescoping steering wheel, Keyswitch, dash display, hand-actuated parking brake lever, forward and reverse direction control lever, tilt/lift and side shift controls, horn button, an emergency stop button, rear view mirror and drivers seat adjustments. See Figures and 3-9.



WARNING

- Driving speed of the truck must be governed by your work environment, such as, slippery floors, cross aisles, slanted driving surfaces, load size, visibility or other people working in the area.
- Never travel at speeds with or without a load that could be dangerous to yourself or others. Also see the Safety section in the beginning of this manual, Chapter 1, "Operator Safety" on page 1-5.

Foot Control Pedals

The foot pedals consists of an accelerator pedal and a brake pedal. The accelerator pedal is pressed by the driver's right foot to control the speed of the truck.

When pressed, the brake pedal applies the service brakes bringing the truck to a safe STOP.

The accelerator pedal is the pedal on the right, and the brake is the pedal on the left. See Figure 3-9.

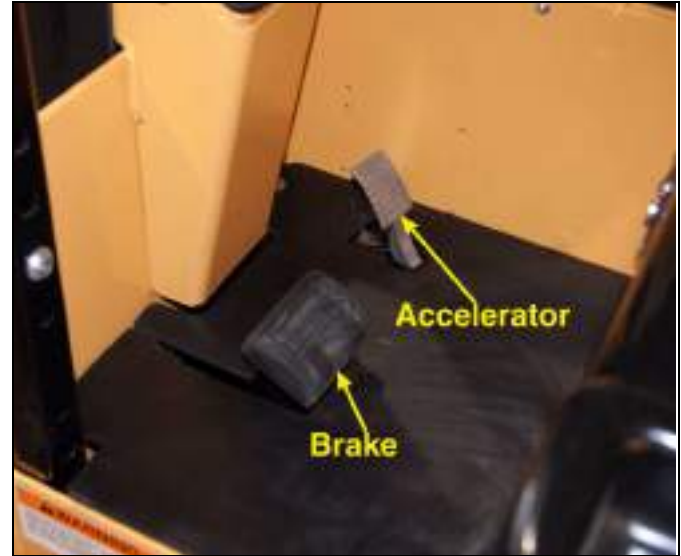

Figure 3-9 Foot Pedals

Hand Operation Controls

Parking (Hand) Brake

The parking (hand) brake is located to the left of the hand control levers. See Figure 3-10.

Direction Lever

The forklift direction control lever is located on the operators control pod. See Figure 3-10.

Lift Lever

The forklift mast lift control lever is located on the front control pod. See Figure 3-10.



Figure 3-10: Control Levers

Tilt Lever

The forklift mast tilt control lever is located on the front control pod. See Figure 3-10.

A visual indicator is provided on the mast tilt cylinder, located on both sides of the mast, so you can easily determine the number of degrees the mast is tilted.

Side Shift Lever

The forklift mast side shift control lever is located on the front control pod. See Figure 3-10. Side shift is a standard function on Bendi B3/30 AC forklifts.

Attachment Lever(s) - Option

A fourth optional function can be fitted via a push button controlled solenoid. The push button is mounted on the side shift lever. Powered attachments are optional functions on Bendi B3/30 AC forklifts.

Horn

The horn control button is located on the control pod, just to the right of the direction control lever. See Figure 3-10.

Rear View Mirror

The rear view mirror is attached to the front top of the overhead guard. The mirror is adjustable up and down, and side to side.

Driver's Seat

The driver's seat is adjustable to accommodate the driver's weight (seat cushion spring tension), backrest tilt and distance from the pedals.

The seat also includes a circuit interrupt safety switch, reference "Seat Safety Switch" on page 1-6.

Seat Belt

The driver's seat belt must always be worn correctly, low and flat across your lap, when driving this truck.

WARNING

A twisted belt can seriously injure you. In a crash or a tip-over, the full width of the belt is required to absorb the impact forces.

Steering Wheel

The steering wheel, is equipped with a steering knob, which should be held firmly with your left hand at all times. See Figure 3-11.

Dash Display

The Dash Display is located in the center of the console, in front of the steering wheel. See Figures 3-2 and 3-11.

The Dash Display shows Battery Discharge Status along with overall truck operational mode status, including Forward / Reverse, Rabbit / Turtle mode, etc.

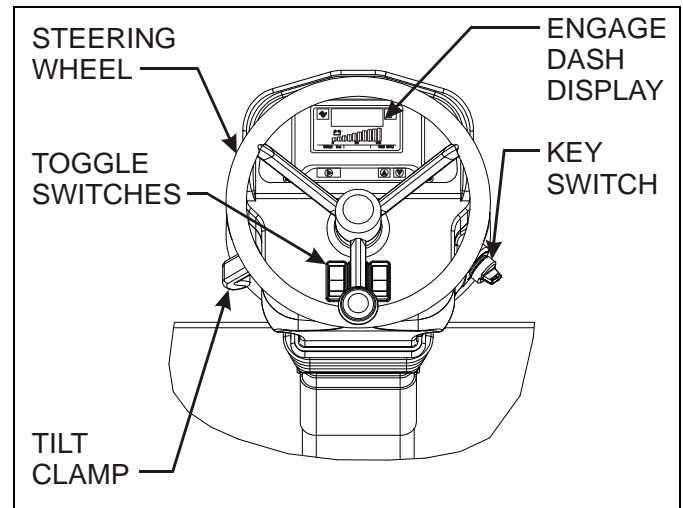

Figure 3-11 Dash Display & Steering Wheel

Understanding Stability



DANGER

- Never load a lift truck beyond its rated capacity. Loading beyond rated capacity can cause axles to break, trucks to tip over, loads to fall, causing serious injury or death. See identification plate for rated capacity and load center information.
- Never allow anyone to stand beneath or pass under the lifting mechanism.
- Make sure that the load is centered and the forks are fully engaged.
- Failure to do so can cause the load to fall, or the truck to tip over, resulting in serious injury or death

The leading causes of accidents involving forklift trucks are due to the lack of understanding how forklift trucks operate, especially when it comes to stability.



DANGER

If you don't understand the concepts of stability, you may tip over the Bendi B3/30 AC forklift truck, which can cause serious injury or death.

Basic Principles

The concepts concerning stability are relatively easy to understand. As the angle between the forks and the body of the truck approaches 90° to the right, See Figures 3-12 or left, See Figures 3-13, the truck is in its least stable position. Unlike an automobile which has four points of suspension, the Bendi B3/30 AC forklift truck operates on a three-point suspension. When the forks are turned nearly 90° to the right, two of the suspension points are on the rear axle (item 1) and (item 2). The third suspension point is the center point of the front wheel (item 3). The center of gravity, an imaginary point at which all of the truck's weight is concentrated, is located as shown (item 4) when:

- The forks are turned nearly 90° to the right.
- No load is placed on the forks.
- The truck is at rest.

In this position, the fulcrum, or axis around which the truck will tip, is between suspension point (item 2) and (item 3).

- If you try to pick up a load that is too heavy, the truck will tip around the fulcrum. Let's discuss why. Imagine a triangle (item 5), drawn between the three suspension points.

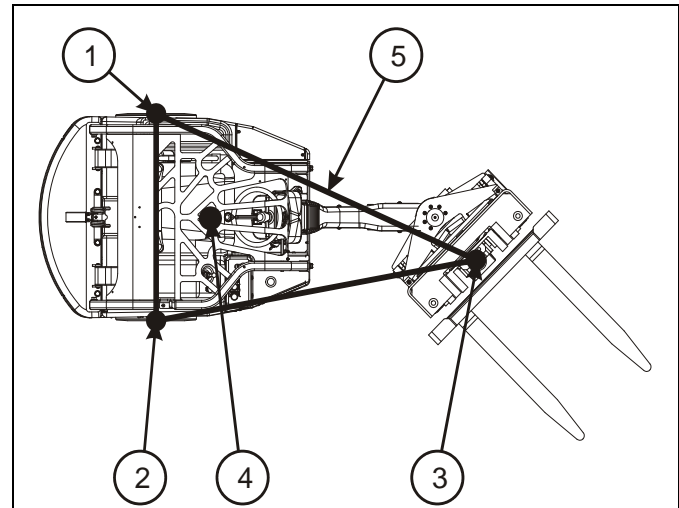

Figure 3-12: Right View 90° Stability

This triangle is commonly called the stability triangle. Since the center of gravity is an imaginary point, it will shift for various reasons that we will explain later. The crucial thing to remember is, as long as the center of gravity of the truck remains within the border of the stability triangle, the truck will not tip. If the center of gravity shifts so it falls outside of the border of the stability triangle, the truck will tip around the fulcrum.

Again, imagine a triangle, drawn between the three suspension points. The forklift is most vulnerable in three conditions: See Figure 3-13.

1. When the forks are loaded, the load is shifted to the left, and the forks are straight ahead, the center of gravity moves to a point along the axis between points (1) and (3).
2. When the forks are loaded, the load is shifted to the right, and the forks are pivoted 90° to the right, the center of gravity moves to a point along the axis between points (2) and (3).
3. When the forks are loaded and the load is too heavy or not properly distributed, the center of gravity moves to a point along the axis points (1) and (2).

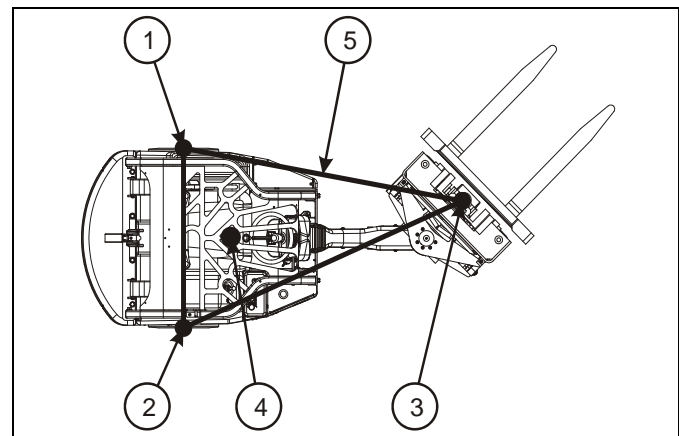

Figure 3-13: Left View 90° Stability

The center of gravity will also shift if:

- The load exceeds the rated capacity listed on the identification plate.
- The load exceeds the load center dimensions listed on the capacity plate.
- You do not seat the forks fully into the pallet, called “tip loading”.
- You take a corner too fast (with the truck unloaded or loaded).
- You drive with the load raised.
- The load is not distributed properly (always keep the heavier items near the load backrest).
- You drive across a slope.
- You drive on a slope with the load facing downhill.

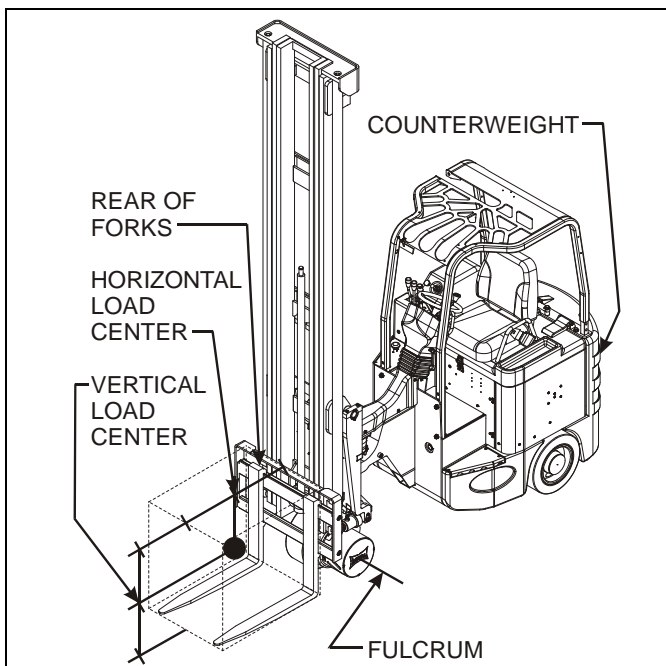

Figure 3-14: Load Center Rating

Load Center



Make sure the actual *horizontal and vertical* load centers do not exceed the maximum load centers stated on the identification plate.

Failure to do so can cause the forklift to tip over causing serious injury or death.

You need to consider *two types* of load centers. The *horizontal* load center is equal to one-half the *length* of the load when the weight is evenly distributed. For example, a load that is 48 in. long has a horizontal load center of 24 in.

The further the load center is from the fulcrum, the less stable the forklift. Always make sure your load is flush against the rear of the forks, and that unevenly distributed loads are loaded with the heaviest end of the load closest to the front wheels. See Figure 3-14.

The *vertical* load center is equal to one-half the *height* of the load when the weight is evenly distributed. For example, a load that is 48 in. high has a vertical load center of 24 in. Make sure that you **do not** pick up a load that is higher than twice the *vertical* load center.

The maximum *horizontal and vertical* load centers your Bendi B3/30 AC forklift can handle is listed on the identification plate.

Counterweight



Never let anyone stand on the back of the forklift to add counterweight. They can fall off the forklift, or the truck can tip backwards, causing serious injury or death.

The battery, left frame plates and bottom plate serve as counterweights and allow the Bendi B3/30 AC forklift to travel with heavy loads. When the forklift lifts a heavy load, the counterweights keep the center of gravity inside the stability triangle and prevent it from tipping over. See Figure 3-14.

Maximum Fork Lift Height



The load capacity of your forklift decreases the higher you raise the forks. Refer to the rated capacity at the heights listed on the identification plate. Failure to observe these guidelines can cause your forklift to tip over, causing serious injury or death.

The maximum fork height is the highest position the Bendi B3/30 AC forklift can lift a load. See Figure 3-15. This is measured from the floor to the forks when they are raised in their highest position. The higher the forks are raised, the less stable the forklift becomes.

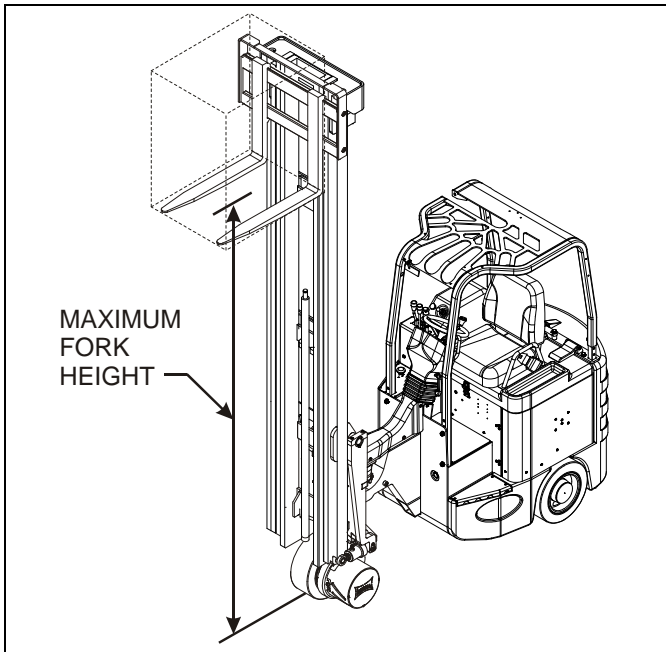

Figure 3-15: Maximum Lift Height

Tilting Considerations

The amount of forward and rearward tilt you should use is governed by the application. When you travel with the truck loaded, you should tilt the mast rearward as well as keep the load low. This will help stabilize loads with an uneven weight distribution. When you load at high heights, tilt the load back far enough to seat it against the load backrest or forks. When you unload at high heights, make sure you only use enough tilt to place the load onto the rack or stack.

Attachments



Never modify the Bendi B3/30 AC forklift in any manner. Only options and attachments approved by Landoll may be installed on the truck. Other modifications will void the warranty and can cause serious injury or death.

Attachments to the forks may affect the load center. When the factory, dealer, or distributor installs attachments approved by Landoll, a modified identification plate is attached to the truck. The new plate identifies the type of attachment, the changes in the load centers, and the rated capacity. It is illegal to use attachments for which revised capacities are not available.

Determining the Weight of the Load

In addition to the rated capacity you must determine the weight of the load **before** you attempt to lift it with the Bendi B3/30 AC forklift:

- Weight is listed on pallet wrapper.
- Weight is listed on Bill of Lading.
- Weight is determined by multiplying the weight of each small container by the number of small containers on a pallet. Each small container should be marked with its weight.
- When in doubt ... Ask your supervisor.

Understanding Workplace Conditions



Workplace situations are constantly changing. Check your area before beginning work for the day. If in doubt, check with your supervisor. Failure to observe new workplace conditions may lead to serious injury or death.

In addition to stability, you need to be aware of special situations in your workplace to avoid forklift accidents. Even if you work in the same area each day, there could be changes that would affect your safety, such as:

- Contractors doing maintenance.
- Wet areas.
- Overhead repair work.

Be on the defensive for anything that might present a hazard. Other situations that could present special operating conditions include:

- Potholes.
- Pedestrian traffic.
- Very narrow aisle ways.
- Overhead obstructions.
- Poor lighting making it hard to see hazards.
- Wet, oily, or uneven terrain.
- Other equipment or vehicles operated in the area.

IMPORTANT

Do not block the following items with the Bendi B3/30 AC forklift, or materials you are moving:

- Electrical panels.
- Fire exits.
- Emergency stop buttons.
- Aisle ways.

Working in Hazardous Environments



DANGER

Some atmospheric conditions encountered in the workplace are extremely explosive and/or flammable. Make sure the Bendi B3/30 AC forklift is designated with the type appropriate for your workplace. If you are unsure about the forklift, check with your supervisor. Using the wrong type designation can cause an explosion or fire resulting in a serious injury or death.

Atmospheric/Electrical

Special atmospheric conditions are explosive and/or flammable. For example, if gasoline or kerosene is stored in the area, the vapors they produce can be flammable and explosive. Make sure the Bendi B3/30 AC forklift meets the criteria for your workplace.

The standard Bendi B3/30 AC forklift meets the criteria for Type “E”, as described in UL 583.

Landoll Corporation also provides special Bendi B3/30 AC forklift trucks that comply with Type **ES** or **EE** designations.

Type ES limits the emission of hazardous sparks and surface temperatures. In addition to these requirements, Type EE requires that the electrical equipment, including the motors, be completely enclosed.

Check with your supervisor if you are not sure which designation is appropriate for your workplace.

Chemical Hazards

You should know the chemical characteristics of the substances you are moving. In case of an accident you would handle stable, reactive, or flammable substances differently. For example, if you puncture a drum that contains flammable material, you need to turn off all sources of ignition and contact the proper authorities.

Operating the Bendi B3/30 AC Forklift

This Chapter of your Bendi B3/30 AC Forklift Operator's Manual explains the concepts that must be thoroughly understood to operate a Bendi B3/30 AC forklift.



DANGER

Read the "Before You Begin (Please Read)" on page 1-1, Chapter 1, in this manual. It contains valuable information, such as stability and rated capacity information you need to know before you operate your Landoll forklift.

Your employer is to make training available, to ensure that you are competent to safely operate the type of forklift that you will be using in the workplace. More information on operator training requirements is included in, Chapter 1, "Operator Safety Training" on page 1-6. Failure to follow the information provided in the "Before You Begin" section or failure to receive proper operator training can cause serious injury or death.

Operator's Daily Inspection

NOTE

Daily inspection is a necessary requirement.

Report any defect immediately to your supervisor.

You are responsible for the daily inspection of your Bendi B3/30 AC forklift: See "Daily Checklist" on page 5-1.

- Photocopy the Operator's Daily Checklist in this Bendi B3/30 Operators Manual, shown in Chapter 5, page 5-1, or use the form supplied by your supervisor.
- Inspect the truck and fill out the form.
- Report defects and return the form to your supervisor.

Basic Operating Instructions



DANGER

Check all systems before operating this vehicle. Report unsafe conditions and correct them before operating vehicle.

Do not operate vehicle unless trained and authorized to do so.

Every forklift operator is to be trained in accordance with rules provided by OSHA, relating to Forklift Trucks.

Your employer is to ensure that each operator is competent to operate a powered industrial truck safely, as demonstrated by the successful completion of training and evaluation.

Operating a powered industrial truck without the proper training can cause serious injury or death.

IMPORTANT

The guidelines here are to give additional information related to this specific forklift truck. This information should never be used in lieu of driver training.



WARNING

To avoid personal injury when operating the truck, be extremely careful that NO part of your body (head, feet, arms, legs) is outside the operator's compartment where it could be subject to injury by aisle supports, other trucks, the mast raising or lowering, or any obstacle in the area.



DANGER

Look in the direction you will travel *before* you begin to drive the forklift.

Failure to look in the direction you are traveling can cause serious injury or death.

Before you operate your Bendi B3/30 AC forklift, familiarize yourself with the controls and indicators. Practice going forward, backward, turning, stopping and parking without a load on the truck. After you become familiar with the truck's operation, learn how to load and unload the forklift.

As the truck operator, you are responsible for observing all speed restrictions and traveling in accordance with aisle and work area conditions.

You are responsible for observing all instructions and safety regulations during your daily work routine related to the use of this truck.

It is your responsibility to thoroughly read the Operator's Manual, paying particular attention to Chapter 1, primarily devoted to Safety, before attempting to operate this truck.

Under normal driving conditions, speed must be chosen according to the situation, such as surface conditions, visibility, people working in the area, moving and fixed objects in the area, cross aisles, etc.

Where visibility is restricted, always travel at very slow speed and ask for a helper ("Banksman") to guide you through the area.

Getting On and Off the Forklift

Always maintain a three-point contact when you get on and off the forklift. Use the steps and hand grips provided for this purpose.

Driving Position



DANGER

- Only operate the vehicle from the operator's seat with the seat belt fastened.
- Do not place any part of your body outside the vehicle.
- Do not carry passengers.
- Failure to follow these guidelines can result in serious injury or death.

For proper seating position:

1. Adjust the driving seat for comfortable operation of the forklift controls. See Figure 4-6. You must be correctly seated with all body parts inside the cab.
2. Fasten your seat belt. See Figure 4-5.



DANGER

Remain in your seat with the seatbelt fastened while the truck is moving. Your seatbelt will help you remain inside of the truck should it tip over. Never jump from the truck if it begins to tip. The truck may land on you causing serious injury or death.

Starting and Traveling

Failure to follow this procedure will result in traction not being enabled.

1. Sit in the seat and face forward.
2. Set the direction lever to neutral. See Figure 4-4.
3. Turn the Keyswitch to the ON, run position.
4. Use the operator controls to raise the forks from the ground and tilt the mast back. According to ANSI B56.1, travel with the forks as low to the ground as possible. This is the recommended traveling position.



WARNING

Driving with the mast in traveling position improves driver visibility and improves the stability of the truck by reducing the possibility of personal injury or damage to the load.

5. Hold the steering knob firmly with your left hand.
6. Set the direction of travel.
7. Gently depress the accelerator pedal as required to achieve a safe operating speed.

Turning



DANGER

**A lateral tip-over can occur if your truck is improperly operated.
Slow down before turning!
Failure to slow down can cause serious injury or death.**

Intersections

When you reach an intersection:

- Slow down. Even if the forklift is not carrying a load it can tip-over if you turn at a high rate of speed.
- Sound the horn as you reach the intersection to warn pedestrians and other equipment operators you are approaching the intersection.
- Always follow the rules of the road and yield to other equipment operators and pedestrians as required.

Stopping

 DANGER
<p>When you stop, stay inside the cab until the truck comes to a complete stop.</p> <p>Failure to stay inside the cab can cause serious injury or death.</p>

 DANGER
<p>Do not apply brakes abruptly with the load raised or tilted forward. If you stop abruptly the load may dislodge from the forks causing serious injury or death.</p>

 CAUTION
<p>Always use right foot for braking.</p> <p>Do not ride the brakes.</p> <p>Do not apply brakes while steering.</p>

To slow down, release the accelerator, and the truck will automatically slow down and stop.

For an emergency stop, release the accelerator and press hard on the foot brake pedal with your right foot.

Stopping Distance

Stopping distance changes with the incline and quality of the road surface.

To make sure you come to a safe stop:

- Reduce speed.
- Allow adequate distance between the truck and any other vehicle, object or person.

Parking

 DANGER
<p>When you exit the vehicle, place controls in neutral and set the hand brake. If you leave the truck unattended, fully lower the mast, turn the truck Off and remove the key.</p> <p>Failure to properly exit and park your forklift can cause serious injury or death.</p>

Before you park the vehicle make sure:

- The parked truck will not cause an obstruction or safety hazard.
- The forklift is clear of fire exits, fire equipment and stairways.
- The truck is not to be left unattended on an incline. If the truck is inoperative and you must leave it parked on an incline, securely block the wheels and remove the key.

When you park your forklift always:

1. Apply the hand brake.
2. Tilt the mast forward.
3. Lower the forks to the ground.
4. Place in neutral, turn the Keyswitch to the OFF position and remove the key.

NOTE

Make sure all accessories are off (lights, etc.) before you turn the Keyswitch to the Off position.

Setting the Forks



WARNING

Make certain the truck Keyswitch is in the OFF position.

The forks must be set equal distance from the center of the fork carriage.

Setting them too far to the left or right could cause a load to unbalance and tip the truck.

Before you get on the forklift make sure the spacing between the forks is properly set. See Figure 4-1.

1. Measure the center to center between the fork openings on the pallet.
2. Lift the fork locks up. See Figure 4-2.
3. Move the forks until the center to center spacing is equal to the center to center distance. Make sure the forks are seated in a carriage notch and equidistant from the ends of the carriage.



WARNING

Never pull a fork toward you as this places your hands in a possible pinch position, which could cause serious injury. Always push the fork away from your body.

4. Press the fork locks down to ensure locking.

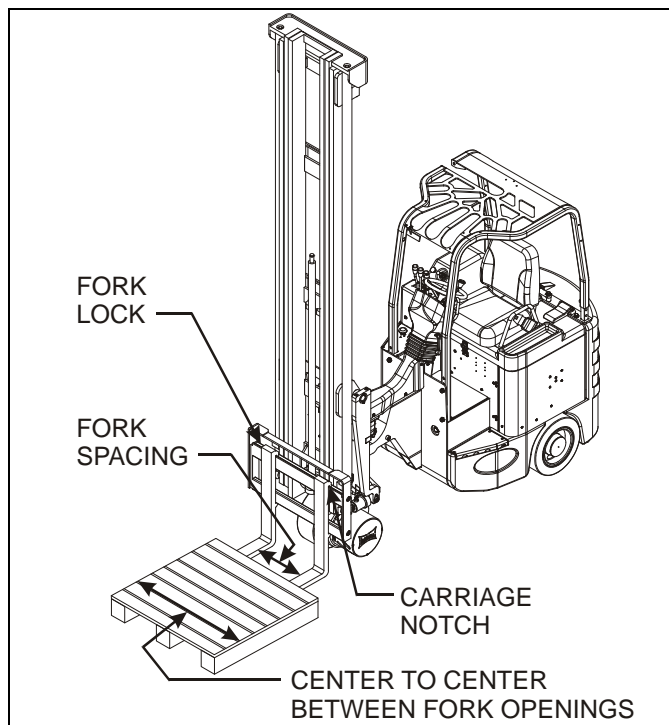

Figure 4-1: Setting the Fork Spacing

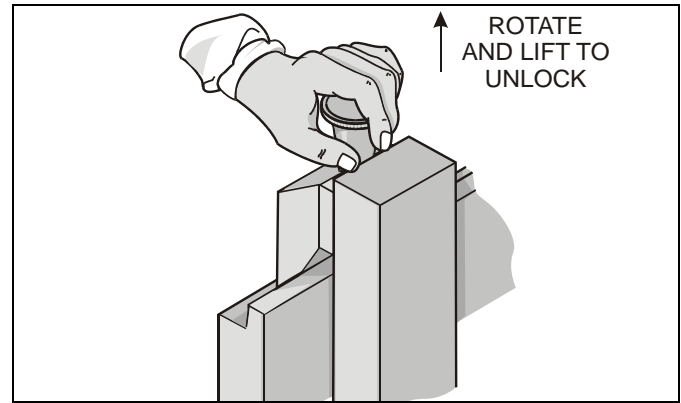

Figure 4-2: Setting the Forks

Controls and Indicators

This section explains how each control and indicator on the Bendi B3/30 AC forklift operate and identifies their location with an illustration.

NOTE

The operation of each control is established by the American Society of Mechanical Engineers (ASME) or Industrial Truck Association (ITA). If you notice that the control operation deviates from the way it is described in this manual, report the operation to your supervisor.

Accelerator Pedal

The accelerator pedal, is located on the floor to the right of the brake pedal. See Figure 4-3.

Pressing the pedal down starts the truck moving, dependent upon the direction you have selected. The closer you press the accelerator pedal to the floor, the faster the forklift moves. Releasing the pedal brings the vehicle to a smooth stop.

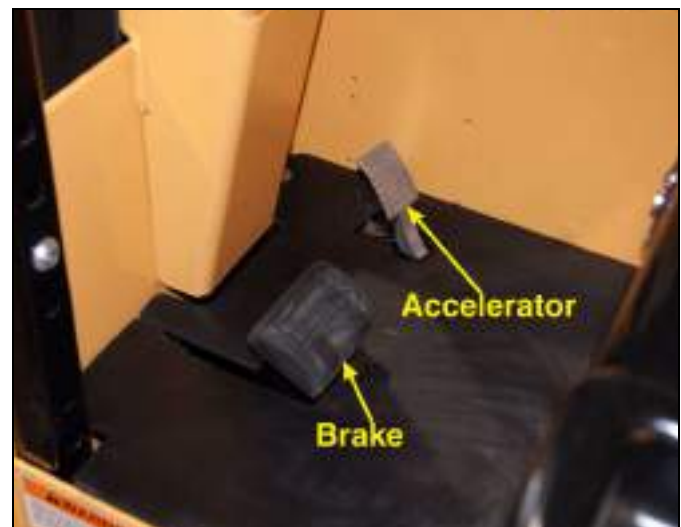

Figure 4-3: Accelerator and Brake Pedals

Brake Pedal



**Always use your right foot for braking.
Do not steer with brakes applied.**

The brake pedal is located on the floor to the left of the accelerator pedal. See Figure 4-3.

The Bendi B3/30 AC forklift will “brake by plugging”. “Brake by Plugging” is accomplished when you release the accelerator pedal, change direction with the direction lever, and press the accelerator pedal again. The motor will come to a smooth stop and then reverse direction. This process is automatic. **DO NOT** press the brake pedal.

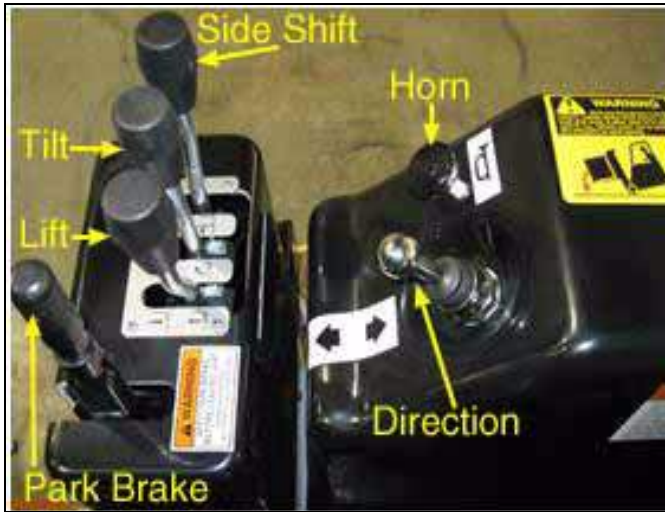

Figure 4-4 Operator Controls

Parking (Hand) Brake

The parking (hand) brake is located to the left of the control levers. See Figure 4-4. Pull the parking brake toward you to set it (pull hard). Push it away from you to release it. You cannot drive the Bendi B3/30 AC forklift while the parking (hand) brake is engaged. The truck will not respond to the accelerator pedal unless you push the parking (hand) brake forward all the way. A parking brake system is fitted to the drum brake system. The system is hand-lever actuated, and is electrically interlocked to create a NEUTRAL condition when the brake lever is actuated. As the lever is raised to apply the brake, the drive and power steering motors shut down and the directional control electrically resets to NEUTRAL, preventing further movement of the truck.

To continue, the operator must first set the direction control lever to NEUTRAL, release the parking brake, then set the direction control lever to the desired direction of travel.

Direction Control Lever

The direction lever is located near the front of the armrest. See Figure 4-4.

Push the lever away from you for forward travel and pull it toward you for rearward travel. The lever may be moved while the truck is in motion “known as “brake by plugging”. The motor will automatically come to a smooth stop and then reverse direction.

Placing the lever in neutral while traveling will bring the vehicle to a quick stop.

Lift Lever

The first lever (closest to the operator) near the front of the armrest is the lift lever. See Figure 4-4.

Pull it back to lift the forks and push it forward to lower the forks.

Tilt Lever

The second lever on the front of the armrest is the tilt lever. See Figure 4-4. Pull it back for backward tilt and push it forward for forward tilt.

Side Shift Lever

The third lever, away from the operator, near the front of the armrest, is the side shift lever. See Figure 4-4.

Side shift is a standard function on Bendi B3/30 AC forklifts.

Pull it back to shift to the right; push it forward to shift to the left.

Horn

The horn is located on the armrest. See Figure 4-4. Depress the button to sound the horn.

Seat Switch

A seat switch, built into the seat, tells the hydraulic controller when you are in the operator’s seat. Traction operations will shut down if the seat switch opens, signaling that you are not in the operator’s seat.

Seat Belt

The driver's seat belt must always be worn while driving a forklift truck.

1. Sit up straight in the driver's seat.
2. Pull the belt across you. Do not let the belt twist. The belt may lock if you pull it across too quickly or stop too soon. If this happens, let the belt go back slightly to unlock it, then pull the belt across slowly.



WARNING

A twisted belt can seriously injure you. In a crash or a tip-over, the full width of the belt is required to absorb the impact forces.

3. Push the latch plate into the buckle until it clicks. Pull up on the latch plate to make sure it is secure. If the belt stops before reaching the buckle, let it go back all the way, then start again.
4. The lap part of the belt must be worn low and snug on the hips, just touching the thighs.

IMPORTANT

Make sure the release button on the buckle is set so you can unbuckle the seat belt quickly in an emergency.

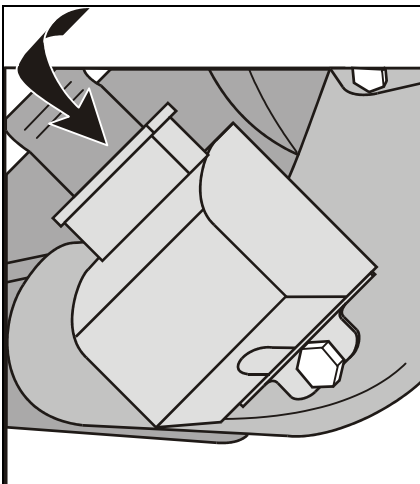

Figure 4-5 Seat Belt Latch

Seat Adjustments

A lever under the front of the seat releases the catch for forward or backward seat adjustment. See Figure 4-6. Weight or suspension adjustment is controlled by a seat adjustment. A gauge showing the adjusted level is located to the right of the adjustment handwheel.

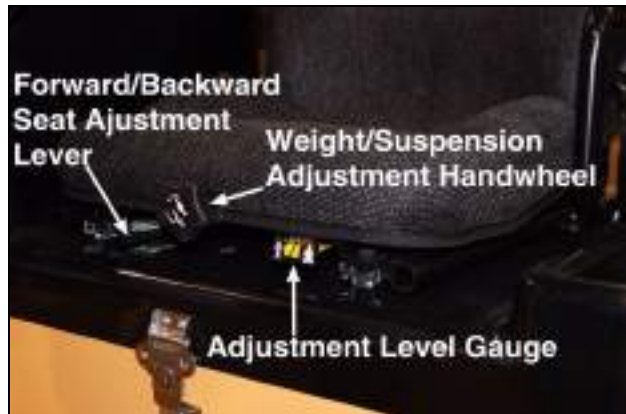

Figure 4-6 Seat Adjustments

Steering Wheel



CAUTION

Adjusting the steering column while driving the truck is dangerous.

Adjustment of the column while driving will cause you to lose control of the truck.

Adjust the steering column only when the truck is not being driven.

The steering wheel, is equipped with a steering knob, which should be held firmly with your left hand at all times. See Figure 4-7.

The steering column is adjustable.

Release the tilt steering adjust clamp and adjust the angle of the steering column.

Tighten the clamp before driving the forklift.

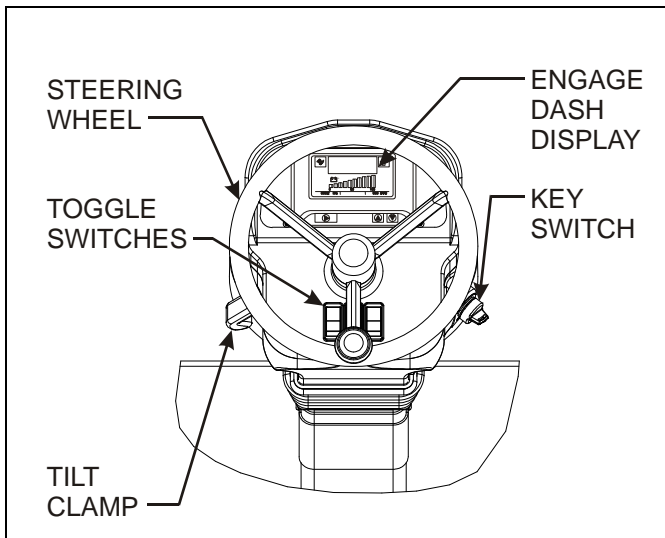

Figure 4-7 Steering Console Components

Dash Display

The Dash Display is centered in front of the steering wheel. See Figure 4-7.

The Dash Display shows Battery Discharge Status along with overall truck operational mode status, including Forward / Reverse, Rabbit / Turtle mode, etc. See Figure 4-8.

Battery capacity (BDI) - monitors the capacity (or percentage) of the battery charge remaining. When the battery drops to 15% of full charge, the lift function is disabled (by shutting off the pump if the lift lever is operated). At this point, the operator has no choice except to return the truck to the charging station. The main purpose of this interlock is to prevent deep discharge of the battery (which shortens battery life), and to also protect the electric motors and other electrical components from damage caused by too low of voltage.

For further detailed dash display operation and calibration refer to the B3/30 AC Maintenance Manual F-560.

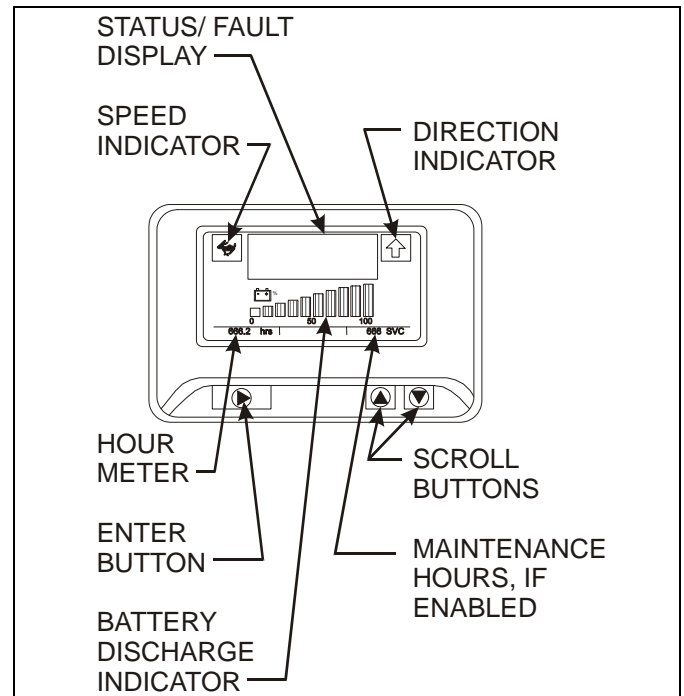

Figure 4-8 Dash Panel Display

Emergency Stop

The emergency stop button is the big red button located on the front of the control box top panel. See Figure 3-2.

Slow/Fast (Std) Mode Switch

The slow/std mode switch is right toggle switch below the steering wheel. See Figure 4-7.

Depress the switch to cut the maximum truck speed by 85%. This button is only to be used when training, gaining familiarity with the truck, and for added control when loading/unloading in a narrow aisle. Depress the button again to return to maximum speed.

Handling a Load

Narrow-aisles, plus the size of the truck can prevent a load from being pulled straight out of the rack. You must rotate the mast and shift (or inch) the load in or out of the rack. A combination of movements, where rotation or shift actions occur with forward or backward movements of the truck, are needed to inch the load in and out of position. This will require some practice by the operator to be performed smoothly and effectively.

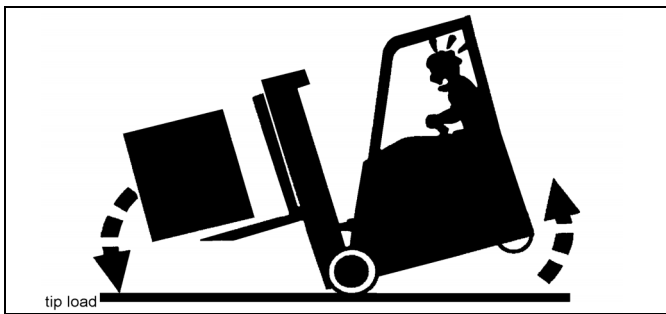

Figure 4-9: Tipping a Load



DANGER

- Look in the direction you will travel before you begin to drive the forklift.
- Make sure forks are set so the spacing between them is equal to one-half the opening between the end stringers on the pallet.
- Make sure you insert forks fully into the pallet. Do not “tip load”. See Figure 4-9.
- Read and understand the information in the “Before You Begin”, Chapter 1, section before you operate a Bendi B3/30 AC forklift.
- Do not handle unstable or loosely stacked loads.
- Use caution when you handle long, high or wide loads.
- Do not allow anyone to stand beneath or pass under the mast.
- Never use the forklift to elevate anyone without the use of an approved attachment.
- Never carry passengers on the truck.
- Never load the Bendi forklift beyond its rated capacity. Rated capacity is stated on the truck’s identification (capacity) plate.
- Loading the truck beyond its rated capacity can cause axle(s) to break, the truck to tip over and/or the load to fall.
- Make sure the load center of the load does not exceed the load center rating stated on the truck’s identification (capacity) plate.
- If the mast continues to raise after the control lever is released, turn off the Keyswitch or use the emergency stop button.
- Failure to follow these guidelines can cause serious injury or death.

Retrieving a Load

NOTES

Actual minimum aisle width will vary based upon application. See Figure 4-10., item 5.

The following illustrations show standard 40 in. x 48 in. (W x L) pallets loaded on a rack with 96 in. beams.

The arrow labeled with an ‘S’ shows the direction you must turn the steering wheel.

Follow these steps to retrieve a load:

1. Approach the side of the aisle that is *opposite* the load, Item 1 - See Figure 4-10.
2. For narrow aisles, straighten out the truck so it is 8 in. from the edge of the aisle opposite the load Item 2 - See Figure 4-10. For wider aisles, straighten out the truck so it is 36 in. to 48 in. from the side of the aisle where the load is located. Item 6 - See Figure 4-10.
3. Center the forks using the side shift lever.



DANGER

If the forks or load jam or catch during a stacking operation, do not attempt to free them by reaching through the mast.

Failure to follow this instruction can cause serious injury or death.

4. Drive forward until the front edge of the load wheels are aligned with the center of the pallet. Items 3 and 4 - See Figures 4-10 and 4-11.
5. Lift the forks to the required height, and then level the forks using the tilt lever.
6. Stop the forklift and turn the forks 90° using the steering wheel to align them with the load. See Figure 4-12.

NOTE

When you turn the steering wheel with the truck stopped, do not apply the foot brake or hand brake.

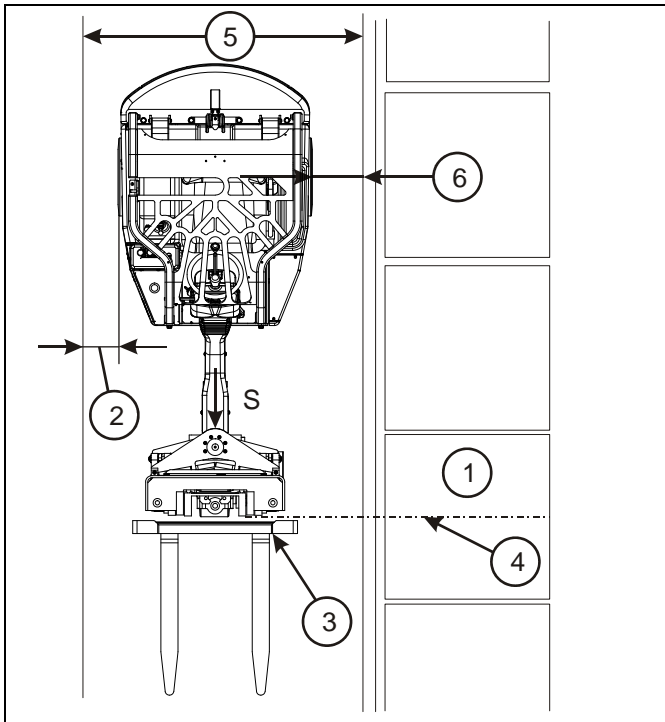

Figure 4-10: Setup - Load Pick Up

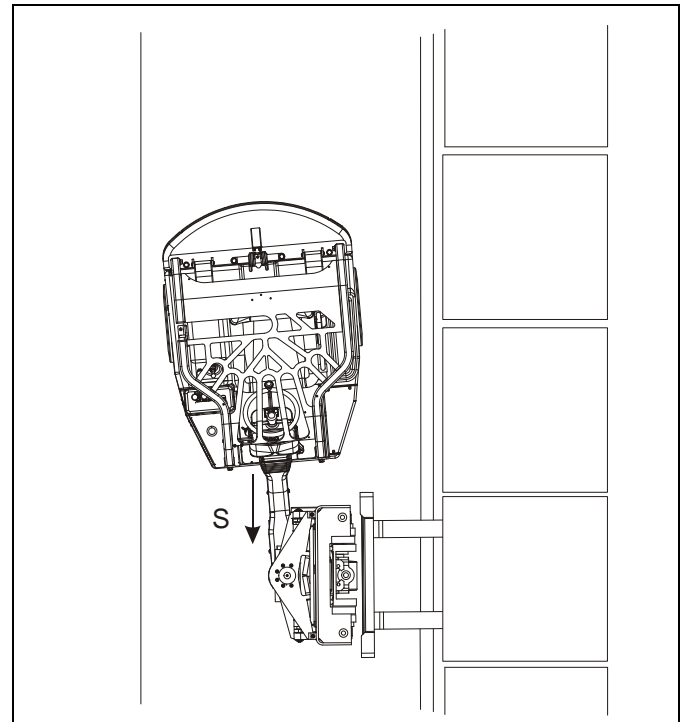

Figure 4-12: Positioning the Forks

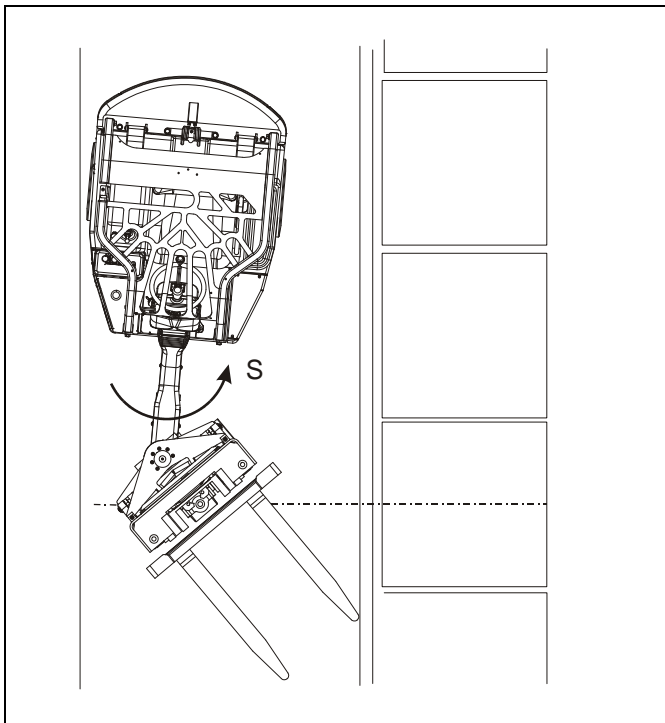

Figure 4-11: Align the Forks

7. Straighten out the forks using the steering wheel as you drive them into the load so the forks enter the load in a straight line. See Figure 4-13.

8. Turn the steering wheel to keep the forks straight as you fully insert them into the load. Lift, tilt, and side shift as required to stabilize and pickup the load. See Figure 4-14. Only raise the load high enough to clear the rack or the load backrest may catch on the rack.

NOTE

All movement may be controlled to a greater extent by the use of the inching procedure.

9. Shift into reverse and slowly back away from the stack as you turn the steering wheel to keep the forks straight. See Figure 4-15.
10. You may need to side shift as you back out the load to clear the rack.
11. If you still are unable to get enough clearance, drive forward and try the removal process again. To get more clearance, don't start turning the forks until you have backed out 8 in. to 16 in..

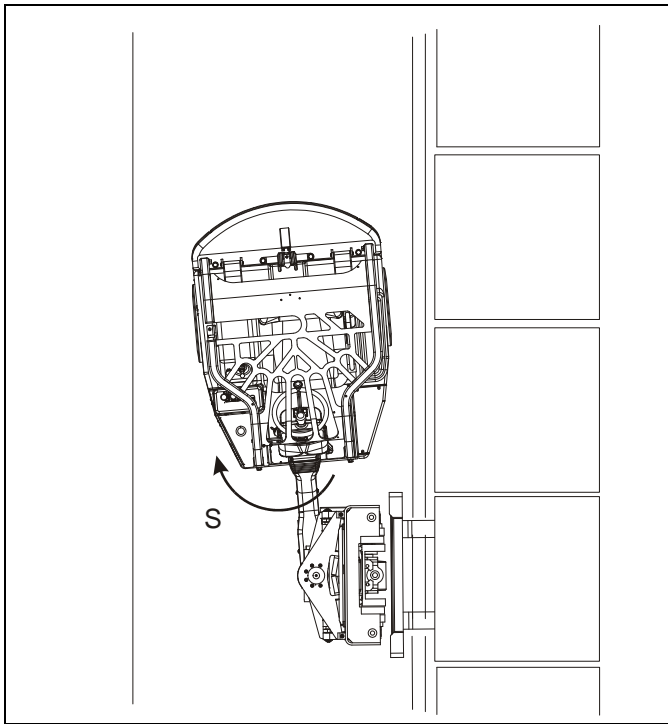

Figure 4-13: Inserting the Forks into the Load

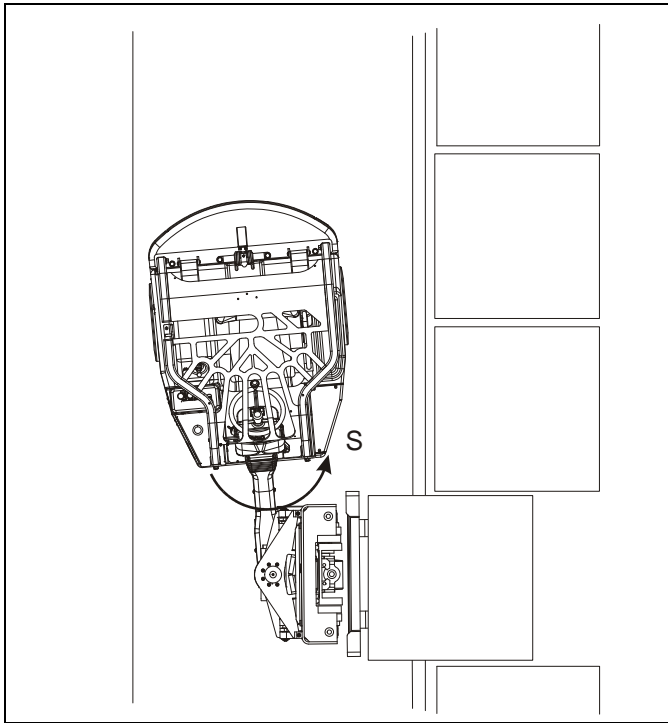

Figure 4-14: Retrieving the Pallet

12. When the front right hand corner of the load clears the rack, stop backing and turn the steering wheel clockwise to straighten out the forks, so they are parallel with the body of the truck. See Figures 4-15 and 4-16.

13. Lower the forks until they are 4 in. to 6 in. off the ground and slowly drive the truck to the next location observing the safety rules previously stated.



WARNING

Lowering the mast improves driver visibility, and improves the stability of the truck by reducing the possibility of personal injury or damage to the load if it were to slip from the forks.

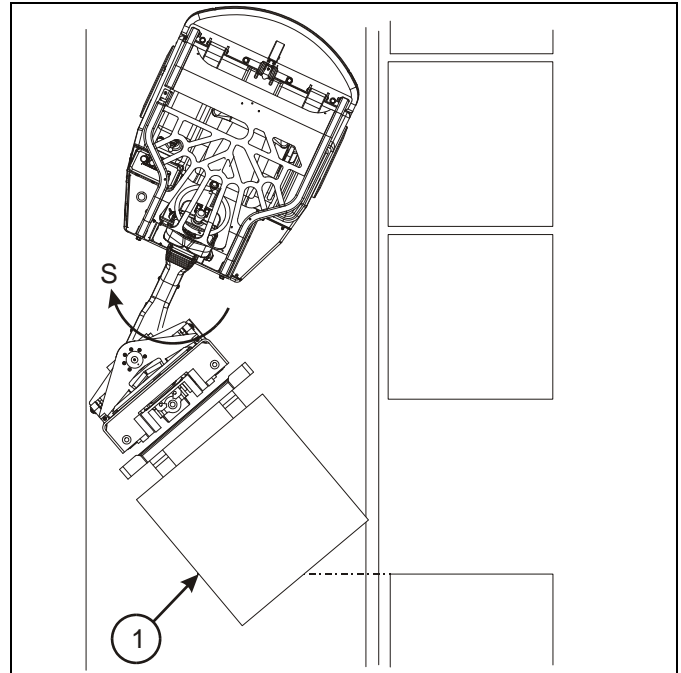

Figure 4-15: Retrieving the Load

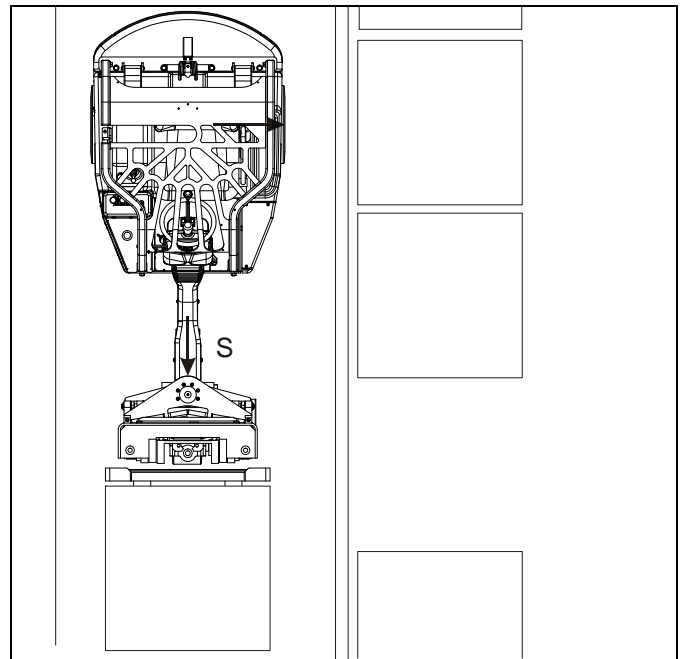

Figure 4-16: Normal Travel Position

Transporting a Load

Follow these guidelines when you transport a load:

- Do not speed.
- Use your horn to warn others of danger.
- Make sure the load is seated firmly against the fork backrest.
- Tilt the mast back.
- Lower the load to recommended traveling position before moving the load to another location.
- Be alert to overhead obstructions such as low doorways, racking and pipes. Make sure you know the raised and lowered heights of the mast.
- Make sure the load is not wider than the width of the gangways or aisles, especially if you are backing a bulky load down an incline.

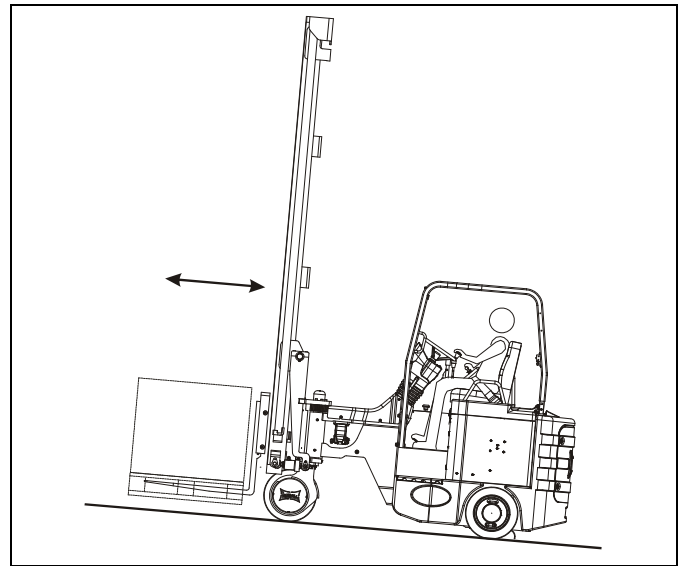

Figure 4-17: Traveling Uphill

Traveling on Inclines



DANGER

**Use extra caution when operating on ramps.
Never travel across a grade.
Travel slowly and do not turn.
Travel with load *uphill*.
Travel with empty forks downhill.
Failure to follow these guidelines can cause serious injury or death.**

When you travel up or down an incline, follow these guidelines:

- Make sure the gradient is 5% or less with a loaded Bendi B3/30 AC forklift and 8% or less if you are not carrying a load.
- **Always keep the load pointed uphill.** See Figure 4-17. Travel with the forks facing uphill whether you are going up or down an incline. You must then back down an incline when you are carrying a load. If vision is obscured, arrange for a 'Banksman' to guide you.
- If you are not carrying a load, travel with the forks facing uphill when you are going up the incline and face the forks downhill when you are traveling down an incline. See Figure 4-18.
- Use the foot brake to maintain control *before* the truck builds up momentum.
- Raise the forks as necessary to avoid damaging the forks or load as the road surface changes grade at the top or bottom of an incline. Lower the forks to 4 in. to 6 in. off the ground when you clear the incline.

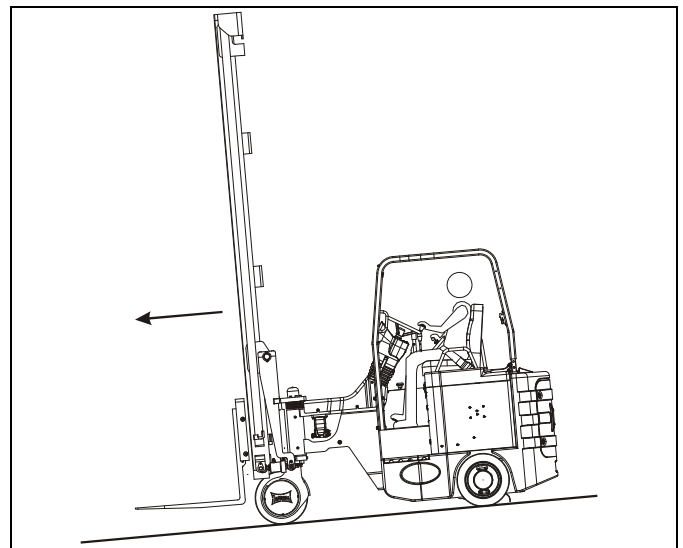

Figure 4-18: Traveling Down an Incline

Unloading The Forklift

NOTES

Actual minimum aisle width may vary based upon application. Item 5 - See Figure 4-19.

The following illustrations show standard 40 in. x 48 in. (W x L) pallets loaded on a rack with 96in. beams. The arrow labeled with an 'S' shows the direction you must turn the steering wheel.

Follow these steps to store a load:

1. Approach the side of the aisle that is *opposite* the area where you will unload the forklift. Item 1 - See Figure 4-19.

OPERATING THE BENDI B3/30 AC FORKLIFT

2. For narrow aisles, straighten out the truck so it is 6 in. to 8 in. from the edge of the aisle opposite the drop off point. Item 2 - See Figure 4-19. For wide aisles, straighten out the truck so it is 36 in. to 48 in. from the side of the aisle where the load is located. Item 6 - See Figure 4-19.
3. Center the load using the side shift lever.
4. See Figure 4-19. Drive forward until the front edge of the load wheels, items 3 and 4, are aligned with the center of the rack opening.



DANGER

If the forks or load jam or catch during a stacking operation, do not attempt to free them by reaching through the mast.

Failure to follow this guideline can cause serious injury or death.

5. Lift the load to the proper height.
6. Stop the forklift and turn the load 90° (turn the steering wheel counterclockwise) so it points in the direction you will drop it off. See Figure 4-20.

NOTE

When you turn the steering wheel with the truck stopped, do not apply the foot brake or hand brake.

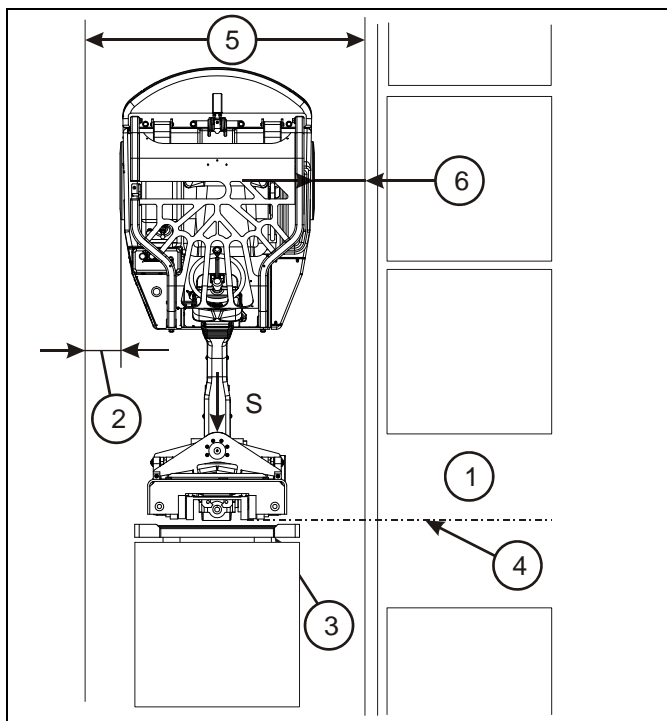

Figure 4-19: Setup - Delivering a Load

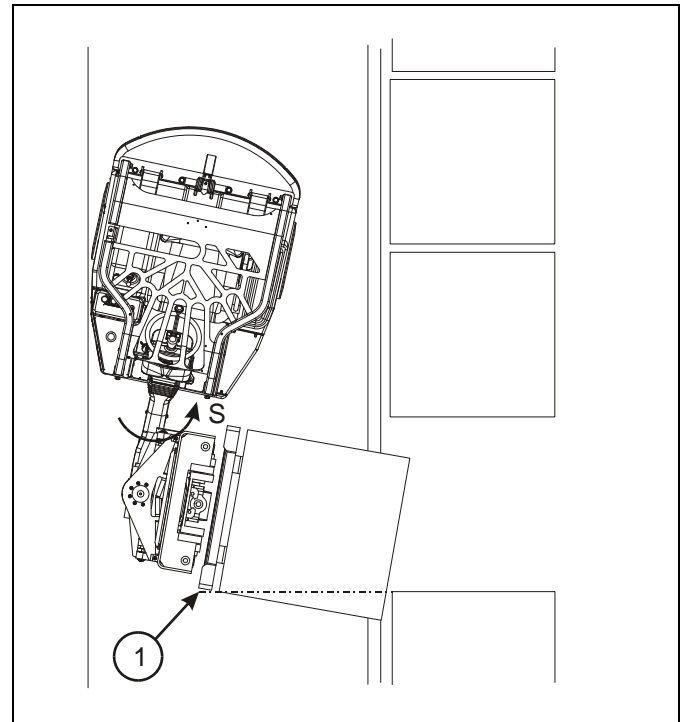

Figure 4-20: Load Drop-Off

7. Drive forward and straighten out the load using the steering wheel so it is square over the stack. See Figure 4-21.

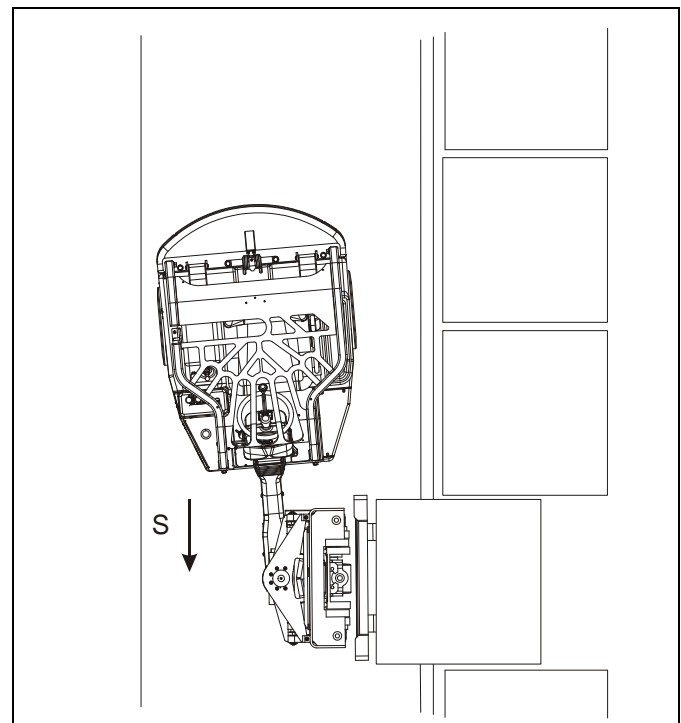

Figure 4-21: Straighten the Load for Drop-Off

8. Turn the steering wheel to keep the load straight as you drive it into the opening. See Figure 4-22.

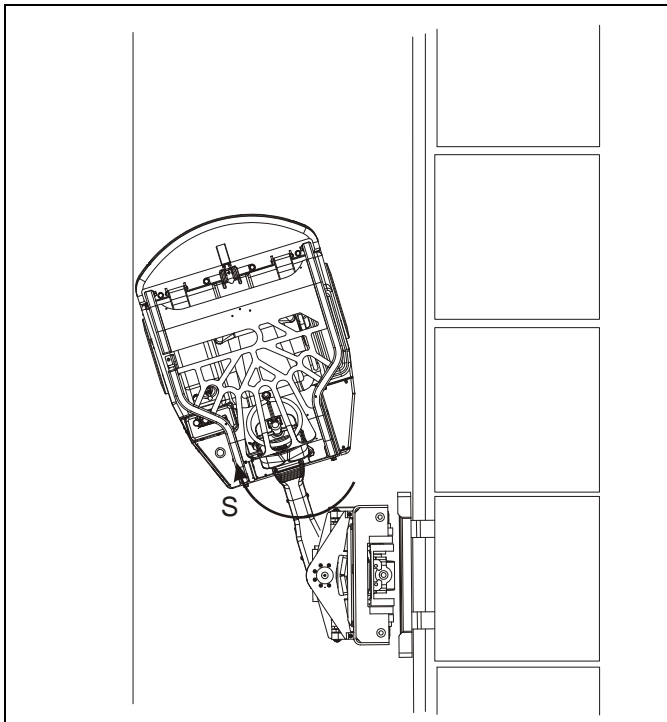

Figure 4-22: Inserting the Load

9. Position the load directly over the rack beams and tilt the mast into its vertical position.

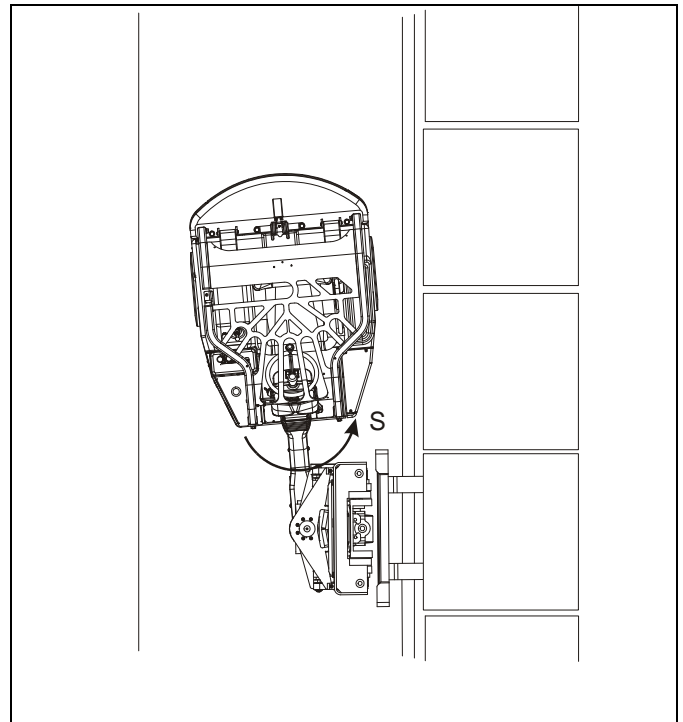

Figure 4-23: No-Load Position

11. Shift into reverse and slowly back out of the load as you turn the steering wheel to keep the forks straight. See Figure 4-24.

! DANGER

When you lower the forks to the “no load” position, make sure you do not lower the forks too far. See Figure 4-23. If the forks are lowered too far beyond the “no load” position, you can damage the mast, rack, or other containers on the stack. This can cause serious injury or death.

10. Lower the forks until the load sits firmly on the rack. Continue to lower the forks until they no longer support the load (‘no load’ position). See Figure 4-23.

! DANGER

Do not attempt to withdraw the forks until they have been lowered to a “no load” position. Failure to follow this guideline can cause the load to fall off the stack causing serious injury or death.

NOTE

Do not tilt the mast back until the forks clear the pallet.

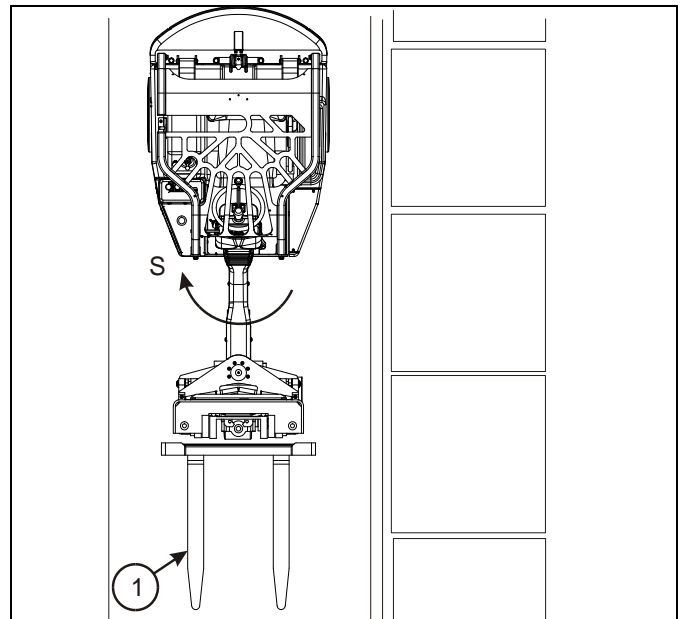

Figure 4-24: Backing Away from the Load

12. When the front right fork clears the rack, stop backing and turn the steering wheel to straighten out the forks so they are parallel with the body of the truck. Item 1 - See Figure 4-24.
13. Lower the forks until they are 4 in. to 6 in. off the ground and slowly drive the truck to the next location observing the safety rules previously stated.

Bendi B3/30 AC Daily Operator Checks

This Chapter of your Bendi B3/30 AC Forklift Operator's Manual details the procedures and information the Operator will need to successfully inspect and maintain the truck on a daily basis.

Inspections Overview

Both Daily and Scheduled maintenance procedures are designed to extend the service life of the truck and prevent major problems, causing costly downtime. The Daily Checklist is provided describing routine inspections, adjustments and lubrication necessary to keep your Bendi B3/30 AC fork lift operating safely, followed by details to facilitate the specific checks.

Maintenance Schedule

A detailed and rigorous full inspection maintenance schedule must be followed and is explained in the "Bendi B3/30 AC Maintenance Manual", F-560.

IMPORTANT

Read and comply with all applicable SAFETY precautions explained in "Safety Information" starting on page 1-1. Recommended service inspections are based on normal operating conditions. If the truck is subject to severe or above normal operating conditions, extreme temperatures, excessive dust or wet environments, or if the truck is around corrosive materials, service must be performed more often.

Daily Checklist

IMPORTANT

Daily Pre-Shift Documented Inspections are an OSHA requirement. Reference page 5-2.

You are responsible for the daily inspection of your Bendi B3/30 AC forklift:

- Photocopy the "Operator's Daily Checklist" or use the form supplied by your supervisor. See page 5-2.
- Inspect the truck and fill out the form.
- Report any defect immediately to your supervisor.

BENDI B3/30 AC DAILY OPERATOR CHECKS

Operator's Daily Checklist	Condition/Operation	Status	Notes
Tires and Wheels	Check Condition		
	Torque Lug Nuts (225 ft-lbs, 300 Nm)		
Static Discharge Straps	Check Condition		
Battery	Check Water, Electrolyte and Charge		
Battery Restraint System	Check Adjustment		
	Check Rollout Switch Operation		
Parking Brake	Check Operation		
Service Brakes	Check Operation		
Accelerator Pedal	Check Operation		
Lift Chains	Check Condition		
Forks	Check Condition		
Electrical Fastener Connections	Check for Loose or Frayed Connections		
Hydraulic Fittings	Check Fittings and Fasteners		
Hydraulic Cylinders	Check for Leaks		
Hydraulic Hoses	Check for Wear and Leaks		
Hydraulic Oil	Check Fluid Level		
Operator Controls	Check Lift/Lower Control		
	Check Tilt Control		
	Check Side-shift Control		
	Check Directional Switch Operation		
	Check Auxiliary Functions		
	Check Horn Operation		
Lights and Alarms	Check Operation		
Steering	Check Operation		
	Check Resistance		
	Check End Stops		
Steer Column Tilt/Extend	Check Operation & Torque Levers		
Dash Display - Gauges	Check BDI Operation		
	Check Hourmeter Operation		
Seat,Belt,Slides,Switch	Check Operation		
Major Structural Points	Check Frame for Cracks		
Overhead Guard	Check Overhead Guard for Cracks and Proper Tight Mounting		
Safety Labels	Replace as necessary		
Capacity Plate	Match Model, Serial No. and Attachments		

Date	Driver	Truck Number	Model Number	Location Number	Serial Number	Shift	Hr Meter	Hydraulic Oil

Tires and Wheels

The condition of the tires is to be checked along with the lug nut torque setting at the beginning of each shift.

The truck is equipped with tires of a size and hardness that provide the necessary traction and still maintain a proper shape to minimize tipping. To maintain stability and maximum reliability you must always replace tires with the type originally supplied, as listed on the specification sheet at the end of this manual. It is also recommended to replace worn tires in pairs. Treaded drive tires must be replaced when the tread depth is less than 0.0625" (1.6mm) at the deepest point.

1. Inspect the tire for chunking or embedded objects. See Figure 5-1. This is caused by running over objects on a littered floor, overloading or bad driving habits - i.e. sharp, rapid turns at high speeds or rapid starts and stops.

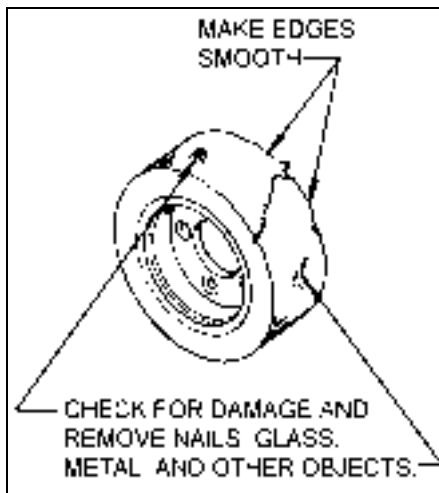

Figure 5-1 Tire wear and Damage

- Remove any embedded foreign material and torn pieces of tread as soon as it is noticed.
 - Replace chunked tires if it produces a rough ride.
2. Inspect tires for undercutting and uneven wear. Undercutting is caused by continuous overloads, rapid sharp turns, operating on slopes, a faulty steer axle, transporting loads with a high center of gravity or transporting off center loads causing the rubber to bulge out over the edge of the steel band, cutting the rubber just above the base band. Uneven tire wear is usually the result of mechanical defects, such as badly adjusted brakes, misaligned wheels or a faulty drive axle.
 3. Check that the tires remain centered on the wheels to prevent splitting of the base band and tread separation. Correct defects as soon as possible.
 4. Flat spotting can occur from excessive heat, a load left on the forks overnight, or locking the brakes with excessive skidding.

5. Avoid oil, grease, gasoline and acid.
6. Torque lug nuts to 225 ft.-lbs. (300Nm) and make sure no lug nuts are missing.

IMPORTANT

If tires have excessive wear and/or chunking, or lug nuts are missing, repair and/or have service replace them immediately. Do not use the truck until repairs are made.

Static Discharge Strap(s)

At the beginning of each shift check the condition of the static strap, attached near the steering pivot point, to ensure it is attached and is dragging the floor. Replace if missing to ensure proper truck operation. See Figure 5-2.



Figure 5-2 Static Discharge Straps

Battery

It is important to properly maintain the battery to ensure long life and strong voltage potential.

The truck battery contains concentrated sulfuric acid which can cause severe chemical burns. When the battery is charging it releases hydrogen, a highly explosive gas.

Shorting the battery terminals together releases enormous amounts of energy causing sparks and flames or it can heat nearby components to dangerous temperatures.

The battery is very heavy and if restraints are not replaced after maintenance the battery could slide out of the truck causing electrical shorts and/or spilling acid. The truck could also tip.

NOTE

If the truck has been shipped with the battery installed first remove the battery from the truck.



WARNING

- Always disconnect the battery before performing any truck maintenance.
- Wear protective clothing and safety glasses when working with battery acid or the battery in general.
- Neutralize acid spills immediately with Bicarbonate of Soda.
- If acid contacts the skin or eyes wash with water immediately and seek medical attention at once.
- Use caution when changing battery connectors to ensure that the polarity is not reversed.
- Keep vent plugs in place and clean at all times.
- When replacing the battery use the same type battery as specified on the truck rating nameplate. Failure to comply could result in an unbalanced condition resulting in tipping the truck and possible injury.
- Close and/or tighten any battery restraints which have been installed on the truck.
- Always assume that the battery is emitting explosive hydrogen gas and practice proper safety precautions.
- Do not smoke, use open flame, create arcs or sparks near the battery.
- Consult the label on your battery for information on cell-type, ampere-hour capacity, charge rate and normal full-charge voltage. Do not charge the battery at a current greater than 1.5 amp per 100 amp-hours capacity at the end of the charge.
- Packaged with every battery are specific instructions for battery care and a Material Safety Data Sheet(MSDS). Read these documents thoroughly before performing any service to the battery.
- Never place any tool or metal object on top of the battery where it could possibly touch battery terminals and cause a short or serious electrical shock.

Removing the Battery From Truck

Replacing the battery requires a lift and support apparatus capable of supporting the weight and size of the battery. Check the capacity plate for battery information.

An external battery roller tray stand is also helpful and will allow the battery to be pushed into the compartment. This is available from your Landoll distributor.

To remove the battery:

1. Return the truck to your service charging area.
2. Set the Keyswitch to OFF and remove the key.
3. Place blocks in front of and behind all wheels.
4. See Figures 5-3 and 5-4.
5. Remove battery door from the forklift.
6. Disconnect the battery/truck cable disconnect and lay the battery cable across the battery.
7. Remove battery restraint and slide the battery out of the truck.

If the battery has been shipped with electrolyte installed check the specific gravity of the electrolyte using a hydrometer to determine if a charge is needed. If the reading is between 1.280 and 1.290 the battery is fully charged. If the reading is near 1.150 the battery must be charged as described in "Charging a Wet Cell Battery" on page 5-5.

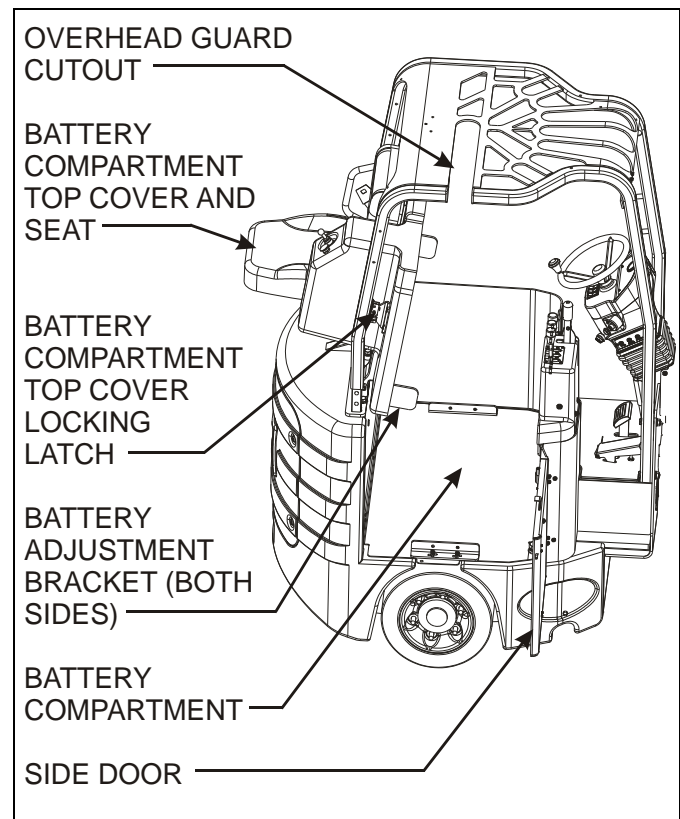

Figure 5-3 Battery Compartment

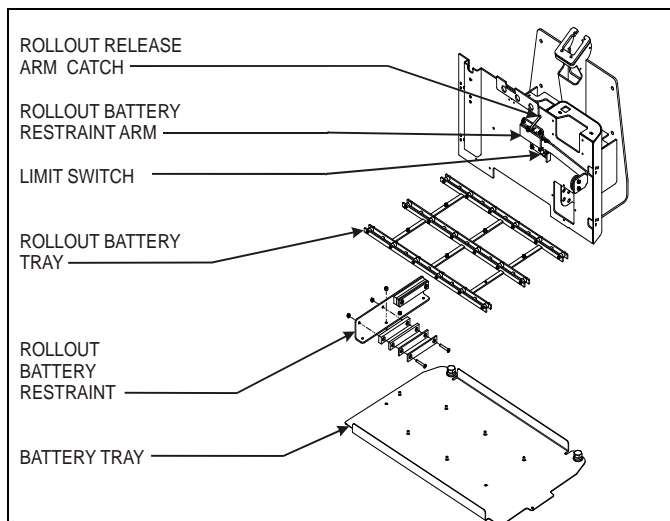

Figure 5-4 Battery Rollout Mechanism

Using a Hydrometer

As the battery discharges the specific gravity of the electrolyte lowers. A hydrometer allows you to check the specific gravity of the cells, thus the charge state of the battery.

To use a hydrometer:

- Remove a cap from one or two of the cells. Gently squeeze (compress) the bulb of the hydrometer.
- Insert the tube of the hydrometer into the cell electrolyte. Slowly release the bulb to allow fluid to draw into the hydrometer. Enough fluid must enter the hydrometer to allow the float to move freely.
- The specific gravity of the electrolyte is read off the scale of the float where it emerges from the fluid.
- It is good practice to select many different and multiple cells.
- When returning the electrolyte to the battery, ensure that the fluid is returned to the cell from which it was taken. Be careful not to splash the electrolyte.

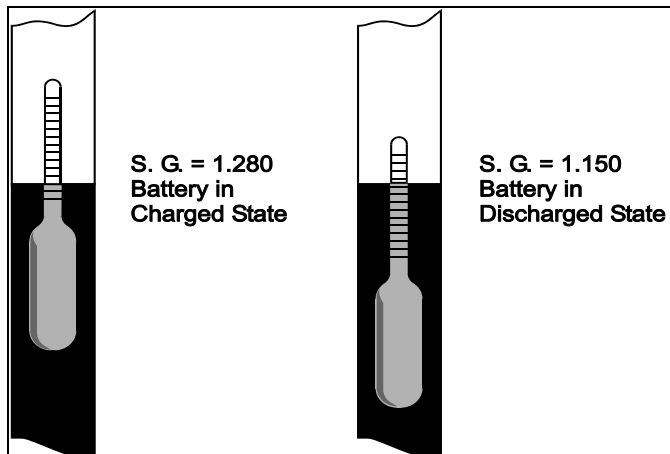

Figure 5-5 Hydrometer

Charging a Wet Cell Battery

1. Remove each vent cap and check electrolyte levels. Ambient temperature should be +77°F (+25°C) to get a proper reading. In cold weather the battery may look dry.
2. Do not add water until an accurate level is obtained; cold weather can affect the level. If water must be added use only distilled water.
3. Make sure the electrolyte level is at the level indicator.
4. Replace the vent caps. They must be secured in place during charging. Ordinarily, the charge should take about 3 to 5 hours to complete.
5. Charge the battery using a constant current charger set to 5% of the six-hour battery capacity. For example, 55 amps for a 1,100 AH (ampere-hour) battery.

IMPORTANT

Do not charge the battery at a finish current which exceeds the rating on the battery nameplate. Consult the label on your battery for information on cell-type, ampere-hour capacity, charge rate and normal full charge voltage. Do not charge the battery at a current greater than 1.5 amp per 100 amp-hours capacity, at the end of the charge.

6. During the initial charge the volume of electrolyte decreases through electrolysis and evaporation. Water approved for use in lead-acid storage batteries should be added if the electrolyte levels falls below the level indicator.
7. If the cell temperature rises higher than +110°F (+61.2°C), either reduce the charging current to half the original value or stop charging until the temperature falls below +110°F (+61.2°C). If you reduce the charging current extend the time accordingly.
8. Refer to Table 5-1 for Specific Gravity correction factors dependent upon electrolyte temperature.
9. Continue charging until the cells out gas freely and the specific gravity remains constant over a three-hour period. At the end of the charge period the cell voltages rise to about 2.55 volts and the specific gravity rises to about 1.280, corrected to 77°F.
10. When charging is complete, ensure the vented cell caps on the battery are secure.
11. Connect battery cables and install battery back into truck.

Temp °F	Correction	Temp °F	Correction
39-41	-0.012	101-103	+0.008
42-44	-0.011	104-106	+0.009
45-47	-0.010	107-109	+0.010
48-50	-0.009	110-112	+0.011
51-53	-0.008	113-115	+0.012
54-56	-0.007	116-118	+0.013
57-60	-0.006	119-121	+0.014
61-63	-0.005	122-124	+0.015
64-66	-0.004	125-127	+0.016
67-69	-0.003	128-130	+0.017
70-72	-0.002	131-133	+0.018
73-75	-0.001	134-136	+0.019
76-78	0	137-139	+0.020
79-81	+0.001	140-142	+0.021
82-84	+0.002	143-145	+0.022
85-87	+0.003	146-148	+0.023
88-91	+0.004	149-151	+0.024
92-94	+0.005	152-154	+0.025
95-97	+0.006	155-157	+0.026
98-100	+0.007	158-160	+0.027

Table 5-1: Specific Gravity Electrolyte Corrections

Battery Restraint System

The battery restraint should be in place at all times when a battery is installed in the truck. A switch that contacts the battery restraint will disable the truck if the restraint is not in place.

Parking Brake

The parking brake system on an Bendi B3/30 AC forklift is manually controlled and is located near the Direction and Lift/Tilt control levers.

To check the park brake:

1. Sit on the driver's seat and turn the Keyswitch to ON.
2. Put the Parking Brake lever in the upward position and attempt drive forward at a very slow speed.
3. The park brake should not allow the truck to move.
4. If any problems are found with the operation of the park brake immediately pull the truck from service, repair and do not use the truck.

Service Brakes

With the Keyswitch set to ON drive forward slowly and then steadily apply the brake pedal. The truck should stop smoothly without noticeable side pull or vibration. Any problems with the brake system must be repaired immediately. Do not use the truck.

Check the Brake Fluid Level

The Master Cylinder reservoir is located under the left side floor plate. Remove the floor plate, remove the threaded fill plug on top of the reservoir and check the levels as indicated. Ensure the oil level reads between the marks.

Accelerator Control

With the Keyswitch set to ON and the direction control in the forward position gradually press on the accelerator. The further you press on the accelerator pedal the faster the truck will go. Let up on the accelerator and the truck should come to a controlled stop. Check to make sure the pedal does not stick or catch. If the accelerator functions incorrectly, remove truck from service immediately and repair.

Lift Chains

Primary Lift Chain (Duplex, Triplex and Quadplex Masts)

Visually inspect the chain for cracks, stretched or stressed links and broken pins. When raising the mast listen for usual chain noise and watch the action of the chain for anything unusual. Watch for unusual pulley movement or pulley wobble that would indicate a worn mast bearing.

Forks



CAUTION

- Do not service carriage forks while the Keyswitch is on. If a control lever is accidentally moved, serious injury could occur.
- It is recommended to use only Landoll Corporation replacement parts. Use only quality forks that are forged or have an up-set heel and that have the same capacity rating as the factory installed forks.
- Never use forks repaired by welding.
- Always replace both forks. Switching forks from one truck to another can be dangerous if the capacity of the forks is not known.
- Check the forks for cracks, closely at the heel portion of the forks. Replace the fork if cracks are found. Never attempt to repair, weld or alter a fork.

Electrical Fastener Connections

Check for loose electrical connections and frayed or broken wires.

Hydraulic Cylinders, Fittings & Hoses

Check underneath the truck for evidence of fluid leaks. Look for hydraulic hose wear, damage and leaks. Make sure clamps and fittings are tight. If leaks are found, have service repair all leaks immediately and check the hydraulic fluid level. Do not drive the truck.

Hydraulic Oil

1. Lower the mast.
2. The Fill/Dipstick is located under the left side floor plate. Remove the floor plate and pull the dipstick. Ensure the oil level reads between the marks.

NOTE

If the truck has been in operation, let the truck sit for several minutes before checking the oil level to allow time for oil to return to the tank.

3. Add oil if oil level is low.

Operator Controls

Lift/Lower Control

With the Keyswitch turned ON, raise the mast. The hydraulic motor should start running as soon as the control is moved out of the neutral position and stop as soon as the control returns to the neutral position. The motor should not run at all when lowering the mast.

Check that the primary mast cylinder extends fully and that the lift carriage rises to the top of the inner rails before the secondary cylinders begin to move.



WARNING

Make sure there is sufficient room above to raise the mast safely and keep all people clear.

When the lift carriage reaches the top of the inner rails the secondary cylinders and middle rails begin lifting. Check to make sure the rails travel smoothly and that there is no chatter or visible binding.

- With the mast fully extended, begin lowering the mast. The secondary cylinders and middle rails fully lower first, followed by the primary cylinder and the lift carriage. Check for smooth travel with no chattering or visible binding.
- If there is noticeable chatter or binding, immediately notify your supervisor or service personnel.

- DO NOT attempt to repair the mast or operate the truck until the problem is corrected.

Tilt Control

Move the tilt mechanism both directions, tilting the mast to both extents, watching for racking. Racking occurs when the tilt cylinder strokes are uneven (One cylinder bottoms before the other). The mast rails then twist, eventually causing them to crack and separate. Proper tilt degree adjust is 1° forward and 2° backward maximum.

1. To check for racking find a reasonably level floor area to park the truck on and center the mast on the truck.
2. Raise the mast about 36" (914 mm) from the floor and tilt the mast full forward and rearward several times watching for twisting at the ends of the stroke.
3. If there is any twisting or racking, both tilt cylinder rods must be readjusted. Remove the truck from service immediately and repair.



CAUTION

If the above scenario is left unattended serious damage to the mast assembly or the tilt cylinders can occur causing extensive repair/downtime.

Side-shift control

Hold down the side shift control, moving the mast left and right several times back and forth to both extents. Listen for any abnormal noise that maybe caused by binding in the side-shift mechanism. If any binding is detected apply grease to the bearing pads immediately.

The side shift bearing pads are located within the slide channels above and below the side shift assembly. The channels are lined (sides, top and bottom) with strips of low-friction plastic pads, embedded with molybdenum di-sulfide, an inorganic lubricant. During the first week of operation it is recommended to lubricate these pads once every day to allow the grease to permeate the pads completely. See Figure 5-6.



WARNING

Do not service the side-shift bearing pads while the Keyswitch is ON. If the control is accidentally moved serious injury could occur.

1. Shift the mast to its full left position, as viewed from the operator's compartment and set the Keyswitch to off and remove the key.
2. Before lubricating the bearing pads and channels wipe off any excess lubricant and dirt buildup from within the channels.

3. Using a small brush paint a thin film of grease to the sides, top and bottom of the side-shift channel surfaces reachable with the mast in this position.
4. Apply a little extra grease to the top surface of the bottom channel pads.
5. Turn the truck back on and shift the mast to its full right position and then turn Keyswitch back to the off position and remove key.
6. Repeat grease procedure that was done on the left side. There are a total of 6 grease points

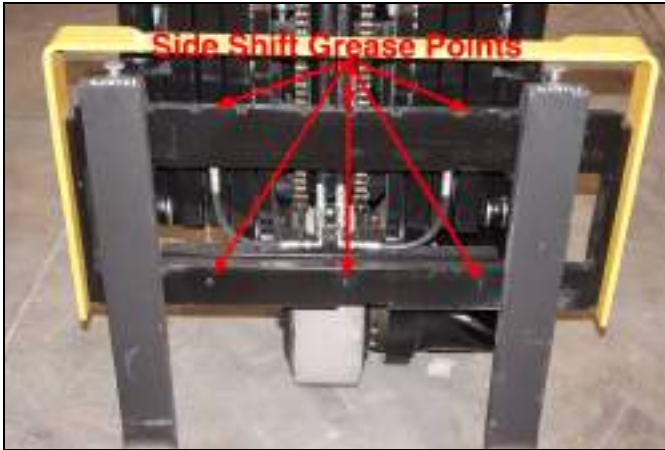

Figure 5-6 Side Shift Grease Points

Directional Control

Rock the directional switch forward to put the truck in forward operation. Press on the accelerator to check. Repeat for the reverse direction by rocking the direction switch backwards.

Static Return to Off (SRO) Function

The static return to off (SRO) is a built in safety feature to prevent accidental truck movement.

To check the SRO:

1. Get in the operator's seat, drive the truck forward, and then come to a stop. Leave the directional control switch in the forward position and turn the Keyswitch to the off position.
2. Turn Keyswitch back to the on position and then press on the accelerator. The truck should not move. Cycle the directional switch to neutral and then back to forward. The truck should now operate correctly.
3. Next, drive the truck forward and come to a stop leaving the directional control switch in the forward position.
4. Lift yourself out of the seat for three seconds. Sit back down and then press on the accelerator. The truck should not move without cycling the directional switch back through neutral.

Auxiliary Function Controls (Optional)

If your truck is equipped with an auxiliary hydraulic attachment, such as a fork positioner, sit in the driver's seat and turn the truck on. Press and hold the auxiliary function control mechanism, moving the control forward and aft. Watch the attachment to determine if it functions properly. If abnormalities are found remove the truck from service and repair.

Horn

Press the horn button located to the right of the direction control lever, near the mast levers. Make certain the horn sounds when button is pushed.

Lights and Alarm

Check lights for proper on/off operation. Check that alarms sound when intended. Repair and/or replace as needed.

Steering

Before operating the truck check the steering system to make sure it operates correctly. The steering is speed sensitive, meaning it requires fewer turns of the steering wheel at lower speeds than faster speeds to turn the front steer wheel lock-to-lock or full rotation.

To check the steering system:

1. Get in the operators seat and turn the Keyswitch to the ON position.
2. Next, while moving forward or backwards slowly, turn the steering wheel clockwise until the steering wheel locks. The front steer wheel should have turned clockwise. Repeat turning the steering wheel counterclockwise and the front steer wheel should turn counterclockwise.
3. While turning the steering wheel there should be a little resistance felt and the steering wheel should not move once the front steer wheel stops rotation.

Steer Column Tilt & Telescope

Before operating the truck adjust the steer column tilt and telescope in a comfortable position and torque the levers tight to ensure the steer column stays locked in place during operation.

Dash Display

Inspect the dash display for errors or faults and ensure that the display reads normal. Check the BDI and hour meter to ensure everything looks normal. If any abnormalities are found remove the truck from service immediately, for repair.

Seat, Belt, Slides & Switch

Check the seat covering for rips or cuts. Check seat belt straps for cuts, worn or frayed areas. Make certain seat slides and adjustments lock in position. Check that the seat belt is firmly attached and that the buckle is not damaged. Check that the seat belt works properly. There is a switch in the seat that detects operator presence. The driver's seat switch system includes an interlock that shuts down the drive and power steering motors and disables the direction control (resets to NEUTRAL) bringing the truck to a Stop. The mast functions remain operable.

To check the seat switch interlock:

1. Get in the operator's seat, drive the truck forward and then come to a stop leaving the directional control switch in the forward position.
2. Lift yourself out of the seat for three seconds. Sit back down and then press on the accelerator. The truck should not move without cycling the directional switch back through neutral. If this interlock does not work, remove the truck from service and repair. Do not use the truck.

Major Structural Points

Rust Or Corrosion

Check the truck frame, side and floor panels for rust and corrosion. Clean rusty or corroded areas and repaint, if applicable. Apply a thin coat of oil to any bare metal surface.

NOTE

Immediately pull truck from service and repair if frame cracks are found.

Overhead Guard

Check the overhead guard, making sure that it is firmly attached to the truck and that all fasteners are secured. The overhead guard is adjustable to accommodate various drivers' and operating restrictions (low ceilings, door openings, etc.).

Safety Labels

Check for damaged and missing decals. Check that the decals are legible. Clean and/or replace as needed. See **page 1-3** and **page 1-4**.

Capacity Plate

The capacity plate should be checked to verify capacity ratings and lift heights. Also check the serial number of the truck and mast to make sure they match up with the corresponding numbers on the capacity plate. See **page 3-3**.

Unusual Noises

The operator, as well as the maintenance technician, should be aware and take action on any unusual noises that may surfaced.

The type of noise, such a grinding or a growl, as well as the location of the noise can determine if or what type of maintenance needs to be taken.

Most grinding noises may indicate a need for mast rail lubrication or a faulty wheel bearing.

Growling noises can indicate faulty hydraulic pumps or simply low oil in the hydraulic tank.

Any unusual noises should be noted in the daily check sheet and reported to the person in charge of repairs and maintenance immediately.

General Truck Lubrication

Inspect lubrication points. See Figures 5-7 and 5-8.

These lubrication points along with proper recommended lubricants ... See Table 5-2 on page 5-10 ... are designed to extend the service life of the truck and prevent major problems, causing costly downtime.



Figure 5-7 Rotation Bearing Grease Points

Recommended Lubricants

See Table 5-2 below for recommended lubricants.

For specific areas to lubricate the forklift - See Figure 5-8.

Name	Lubrication	Comments
Chain	SAE40W oil or Bowman Heavy Load Red Grease	Clean and reoil
Upright Rail	Chassis Lube or Kendall SR-12X	Lubricate inner sides of upright rails
Rotation Bearings	Mobil XHP222	Mobil XHP222
Hydraulic Reservoir	Amoco Rykon MV	Drain, flush, and refill
Gear Case	Mobilube SHC-630	Drain, flush, and refill
Articulating Axle Bearings	Mobil XHP222	Use standard lubrication gun
Load Wheel Axle	Mobil XHP222	Use lubrication gun and adapter for flush type fittings
Steering Gears	Mobil XHP222	Brush or spray on lubricant
Tilt Cylinders	Mobil XHP222	Use standard lubrication gun
Splines of the Drive Motor and Gearbox	Kluberplex BEM 34-132	Apply to splines

Table 5-2: Lubrication Chart



Figure 5-8: Lubrication Points

Technical Specifications

Table 5-3: Standard Specifications

Model	B3/30 AC
Capacity @ 24" Load Centers	3,000 lbs. / 1,361 kg
Load Center	24 in. / 600 mm
Power Source	Battery, Electric 48V
Weight w/ Battery	12,800 lbs./6,146 kg
Travel Speed Loaded Unloaded	5.6 mph / 9.7 kph 6 mph / 11.3 kph
Lift Speed Loaded Unloaded	90 fpm / 29 mpm 110 fpm / 33.5 mpm
Lower Speed Loaded Unloaded	100 fpm / 24.4 mpm 90 fpm / 22.8 mpm
Mast Tilt (Forward/Reverse)	1° / 2°
Standard Forks (ITA Class II)	40 x 4 x 1.5in. / 1016 x 101 x 38mm
Gradeability (Loaded)	8% Empty, 8% Loaded
Lift Motor Rating	12kW
Front Articulation	200° - Full Left to Full Right Travel
Traction Motor Rating	5.1 kW AC
Wheel Sizes Front (1 each) Rear (2 each)	18 x 7in. (457x178mm) 18 x 7in (457x178mm)
Battery Recommended - 48V	24-125-13, 48 Volt, 680 AHC(6 hr rate)
Battery Weight	Minimum 2,600 lb. / 1,180 kg Maximum 3,100lb. / 1,497 Kg
Control Type Traction Hydraulic Lift	AC AC

* Technical Specifications Subject to Change.

BENDI B3/30 AC DAILY OPERATOR CHECKS

Document Control Revision Log:

Date	Revision	Improvement(s) Description and Comments
10/29/10	F-548-1010	Initial Release
nn/nn/nn	F-	
nn/nn/nn	F-	



Equipment from Landoll Corporation is built to exacting standards ensured by ISO 9001:2008 registration at all Landoll manufacturing facilities.

Bendi Model B3/30 AC

Operator's Manual

Re-Order Part Number F-548-1010

LANDOLL CORPORATION

1900 North Street

Marysville, Kansas 66508

(785) 562-5381

800-428-5655 ~ WWW.LANDOLL.COM



Copyright 2010. Landoll Corporation - Author Tech Comm Zeke

"All rights reserved, including the right to reproduce this material or portions thereof in any form"