

SERVICE MANUAL

AOS

ADVANCED OPERATION SYSTEM



FINGERTIP

**FB-70
SERIES**

AC

NICHYU
NIPPON YUSOKI CO.,LTD.
KYOTO. JAPAN

CONTENTS

1. OUTLINE OF TRUCK WITH PROPORTIONAL CONTROL VALVE 1

1-1. Model and specifications.....	1
1-2. AOS function	1
1-2-1. Features	1
1-2-2. Automatic fork leveling	2
1-2-3. Hydraulic system emergency stop	2
1-2-4. Automatic speed reduction at high lifting height	3
1-3. Names and functions of the device	4
1-3-1. Overall appearance	4
1-3-2. AOS switch	6
1-3-3. Monitor display	9
1-4. MPU board	10
1-4-1. Travel/Hydraulic board	10
1-4-2. Display board	10

2. OPERATION PROCEDURES FOR TRUCK WITH PROPORTIONAL CONTROL VALVE 11

2-1. Operation procedures.....	11
2-1-1. Joystick operation	11
2-1-2. Automatic lifting stop operation	12
2-1-3. Switching the automatic fork leveling mode	15
2-1-4. A/B rack switching	16
2-1-5. Lifting height limit mode switching	16
2-1-6. Storing the stop position	17
2-1-7. Stop (emergency stop) operation	21

3. ADJUSTMENTS OF TRUCK WITH PROPORTIONAL CONTROL VALVE 22

3-1. Adjustments	22
3-1-1. Memory clear	23
3-1-2. Optional setting	24
3-1-3. Adjusting the potentiometer for tilting angle detection	27
3-1-4. Storing the tilt end/level position	28
3-1-5. Storing the lift end	30
3-1-6. Setting the distance of the picking and stacking heights	33
3-1-7. Lift end speed reduction setting	35
3-1-8. Tilt end speed reduction setting	37
3-1-9. Switching of fork leveling and A/B rack	39
3-1-10. Lever potentiometer adjustments	41
3-1-11. Solenoid valve current adjustments	43
3-2. Final check	45
3-2-1. Checking the accuracy of automatic lifting stop	45
3-2-2. Checking the accuracy of automatic fork leveling	46
3-2-3. Checking the solenoid valve current	46
3-3. Speed limit at high lifting height	47

1. OUTLINE OF TRUCK WITH PROPORTIONAL CONTROL VALVE

1-1. Model and specifications

FB-70 truck with proportional control valve

[Spec. 1]	AOS (lever type)	2 - 4 spools
[Spec. 2]	AOS + Fingertip control (joystick type)	3/4 spools
[Spec. 3]	Fingertip control (joystick type)	3/4 spools

1-2. AOS function

1-2-1. Features

Shockless loading

If the valve lever is operated rapidly, the fork operation starts smoothly to prevent the load from collapsing. Even the beginners can operate the lever safely.

Automatic lifting stop

The desired lifting height can be memorized up to 6 levels. Pressing the picking/stacking button automatically lifts and stops the forks at the specified height.

Automatic fork leveling

The forks can be automatically stopped in a horizontal position by operating the tilt lever.

The operation, supervised and controlled by the operator, will be executed automatically and securely.

Automatic speed reduction at high lifting height

The travel speed is automatically controlled according to lifting height.

Loading operation at high position can be performed safely.

1-2-2. Automatic fork leveling

When the fork tips are lifted upward

Engage the automatic fork leveling mode by pressing the AOS switch (the LED lights up) and push forward the tilt lever. The forks automatically stop at the horizontal position.

- If you want to tilt the forks upward or downward further, return the tilt lever to the neutral position and operate it again.

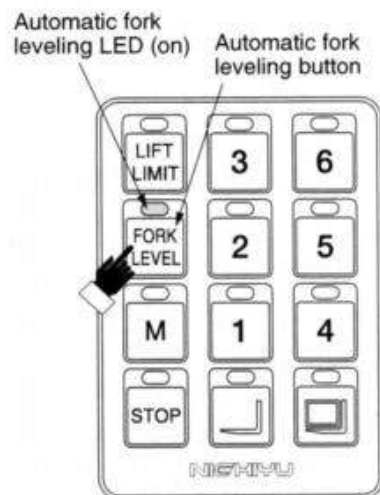

2211248E

1-2-3. Hydraulic system emergency stop

Pressing the emergency switch turns off the electrical circuit of the hydraulic system.

To restore the hydraulic system

Perform the following operations.
(This system's priority is safety first.)

- 1 Cancel the emergency stop. (While holding down the emergency switch, turn it clockwise.)
- 2 Turn OFF the key switch of the truck and turn it ON again.

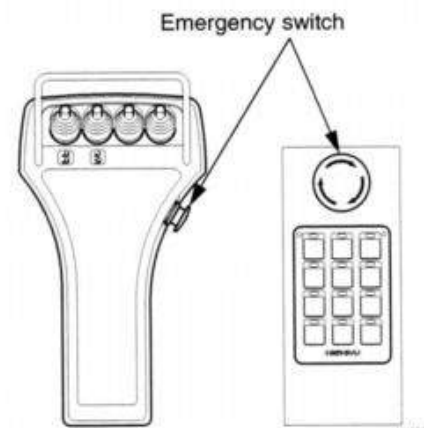

- [Spec. 2] : AOS + Fingertip control
- [Spec. 3] : Fingertip control

- [Spec. 1] : AOS (lever type)

CAUTION

The automatic lifting stop and automatic fork leveling operations work with the highest accuracy when there are no loads. When loads are stacked, the accuracy is reduced.

1-2-4. Automatic speed reduction at high lifting height

- Lifting the forks high automatically activates the slow speed mode and reduces the travel speed.
(For the lifting height and speed limit, refer to "3-3. Speed limit at high lifting height" on page 47.)
- When the slow speed mode switch (turtle) is pressed, the slower speed is prioritized.
The same display as that of the turtle switch appears on the monitor.



Slow speed mode switch (turtle) 2211172

1-3. Names and functions of the device

1-3-1. Overall appearance

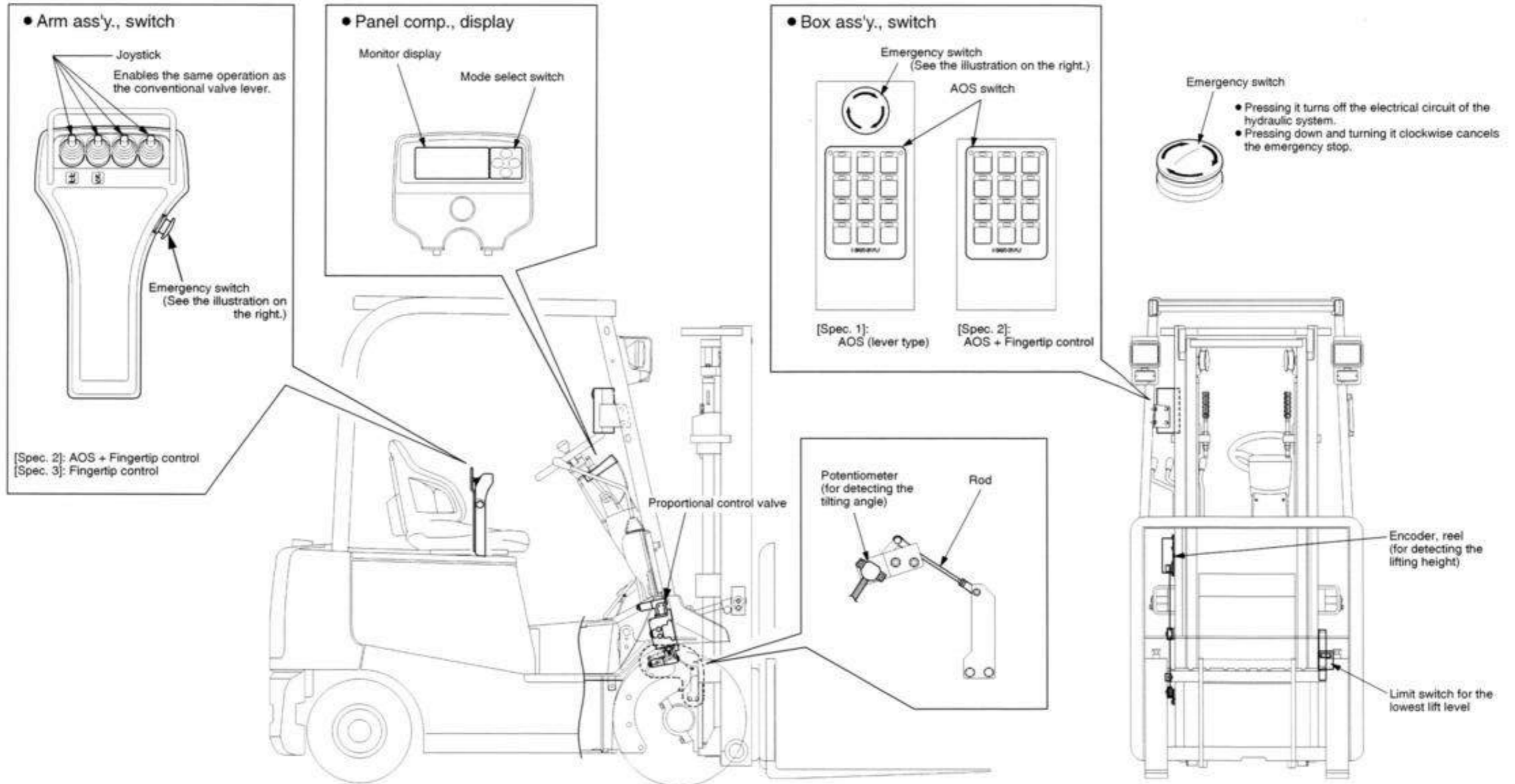

1-3-2. AOS switch

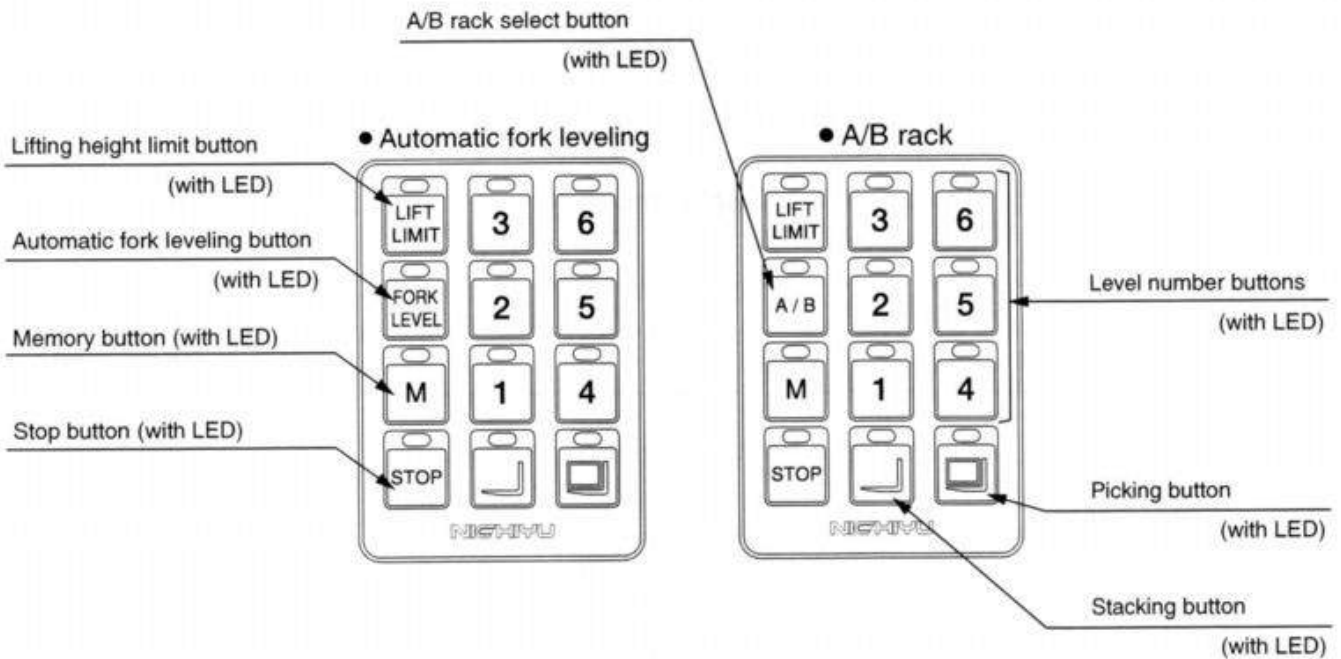

2211230E

Lifting height limit button/LED

Enables or cancels the lifting height limit mode.

- When the mode is enabled, the LED lights up.
- When the mode is canceled, the LED goes off.

It is also used to set (store) the lifting height.



2211221E

NOTE

When the truck is in the lifting height limit mode, the forks automatically stop at the preset height and cannot be operated manually. When the height of the forks exceeds the limit, the LED flashes.

Automatic fork leveling button/LED

Enables or cancels the automatic fork leveling mode.

- When the mode is enabled, the LED lights up.
- When the mode is canceled, the LED goes off.
- When the forks stop in the horizontal position in this mode, the LED flashes.



2211220E

A/B rack select button/LED

Allows you to select A or B rack.

- When the A rack is selected, the LED goes off.
- When the B rack is selected, the LED lights up.

NOTE

The previously stored lifting height limit is applied according to the selected rack.

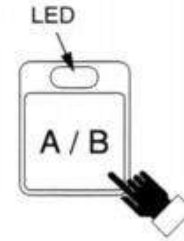

2211233

Memory button/LED

It allows you to set the lifting height where the forks are automatically stopped.

In the memory mode, the automatic stop position can be stored by pressing the level number buttons and the lifting height limit position can be stored with the LIFT LIMIT button, and the lifting height for automatic stop can be set or reset.

- When the lifting height is set (memory mode), the LED lights up.
- When the lifting height is reset (normal mode), the LED goes off.

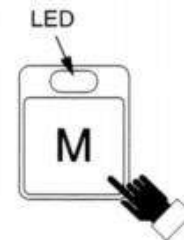

2211234

Stop button/LED

It allows you to cancel the automatic lifting stop operation or interrupt the valve lever operation.

By pressing the button after specifying the level number, the operation can be stopped.

When the valve lever operation is interrupted, the LED remains lit for a certain period of time (approx. 5 seconds) after returning the valve lever to the neutral position.



2211235

Level number buttons/LEDs

Allows you to specify the lifting height level where the forks are automatically stopped.

- You can only specify the level number buttons in which LEDs are on.
- They are also used to set (memorize) the lifting height.

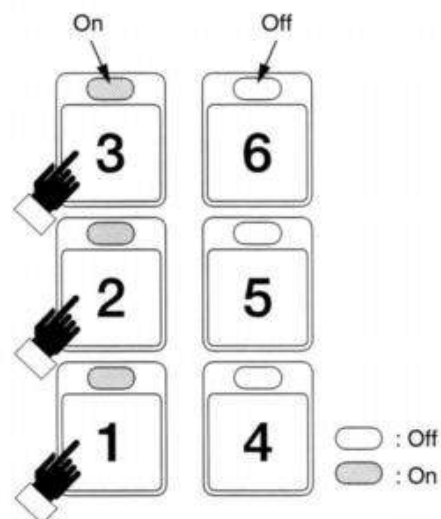

221129K

Picking button/LED

Press it to lift the forks automatically up to the loading height after specifying the level number.

- While lifting up the forks, the LED lights up.
- When the lifting operation is completed, the LED flashes.
- When canceling the lifting operation or lifting up manually, the LED goes off.

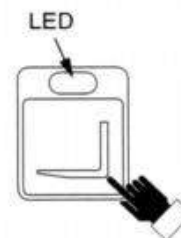

2211297

NOTE

After the level number is specified, both the picking LED and stacking LED light up.

Stacking button/LED

Press it to lift the forks automatically up to the unloading height after specifying the level number.

- While lifting the forks up, the LED lights up.
- When the lifting operation is completed, the LED flashes.
- When canceling the lifting operation or lifting up manually, the LED goes off.

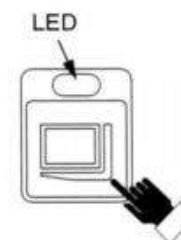

2211298

NOTE

After the level number is specified, both the picking LED and stacking LED light up.

1-3-3. Monitor display

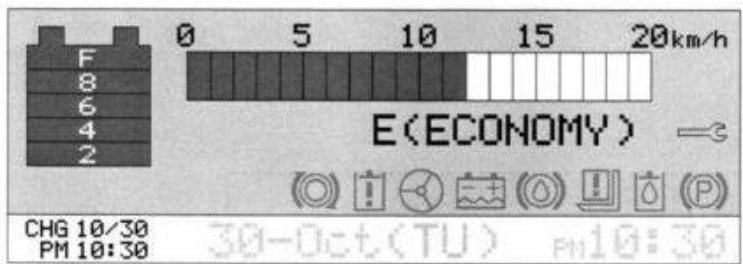
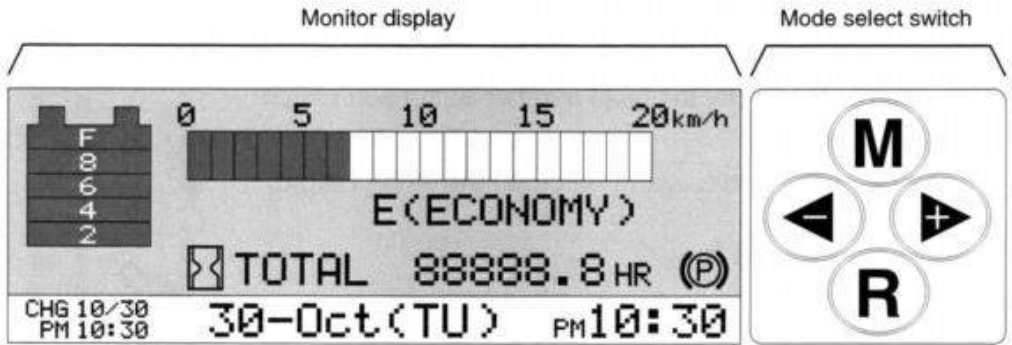

Slow speed mode switch (turtle)

1-4. MPU board

1-4-1. Travel/ Hydraulic board

- Boards of PBC100-93C (program: T70100+T80100) or above can be used.

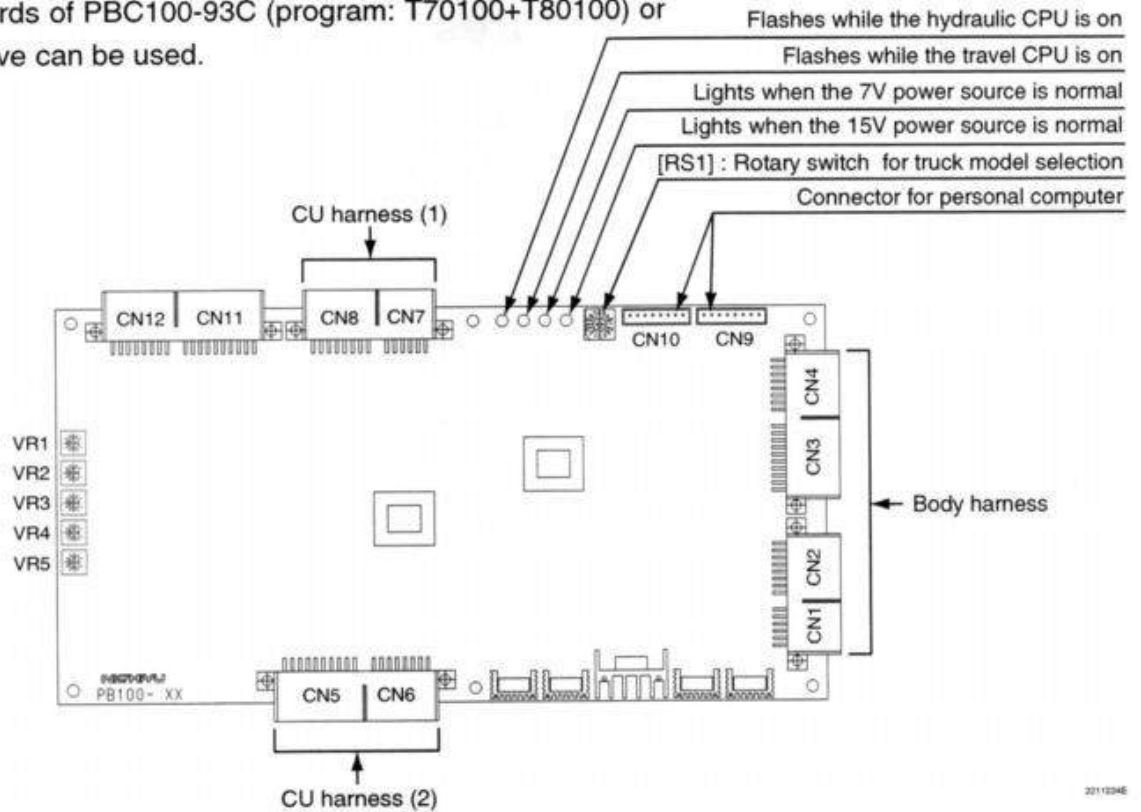

2211294E

1-4-2. Display board

- Boards of PB101-23D (program: L10200) or above can be used.

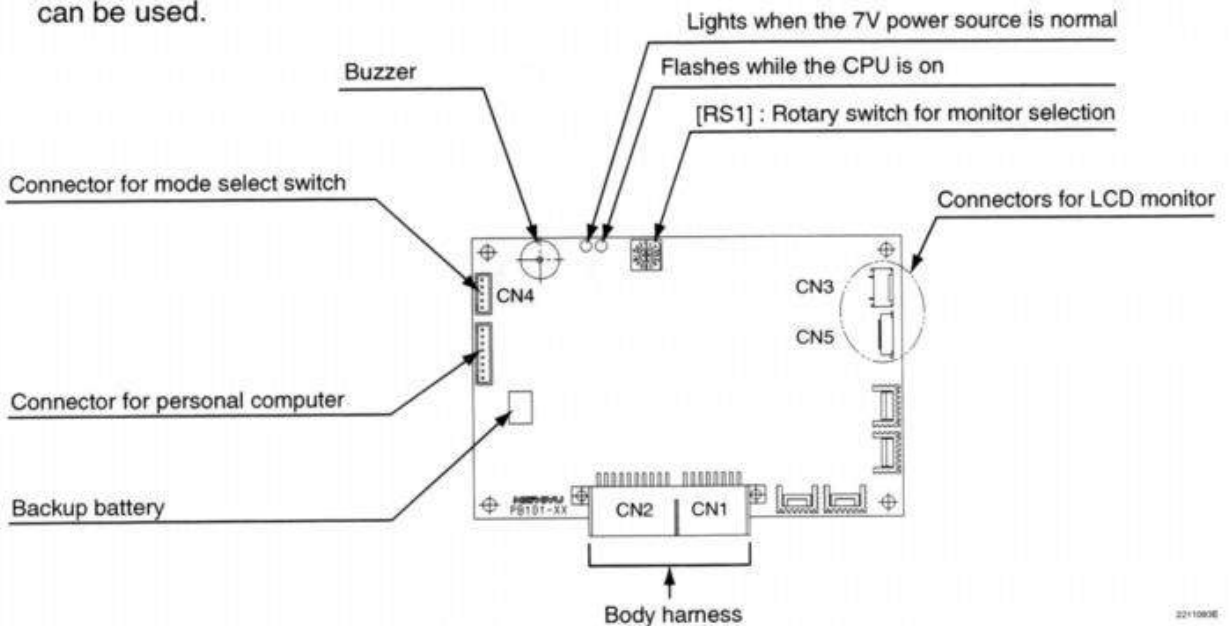

2211295E



Even when the key is turned off, voltage from the battery is still sent to the display board. Disconnect the battery plug before performing this work.

2. OPERATION PROCEDURES FOR TRUCK WITH PROPORTIONAL CONTROL VALVE

2- 1. Operation procedures

<Operation procedures list>

For the AOS model, either "Automatic fork leveling" or "A/B rack" can be selected.

[Spec. 1]: AOS
 [Spec. 2]: AOS + Fingertip control
 [Spec. 3]: Fingertip control

Item	Specification	[Spec. 1]		[Spec. 2]		[Spec. 3]
		Automatic fork leveling	A/B rack	Automatic fork leveling	A/B rack	
2-1-1. Joystick operation	P.11			○	○	○
2-1-2. Automatic lifting stop operation	P.12 - P.14	○	○	○	○	
2-1-3. Switching the automatic fork leveling mode	P.15			○		
2-1-4. A/B rack switching	P.16		○			
2-1-5. Lifting height limit mode switching	P.16	○	○	○	○	
2-1-6. Storing the stop position	P.17 - P.20	○	○	○	○	
2-1-7. Stop (emergency stop) operation	P.21	○	○	○	○	

2-1-1. Joystick operation

Joysticks for "Lift", "Tilt", "Att. 1" and "Att. 2" can be operated as same as the normal valve levers.

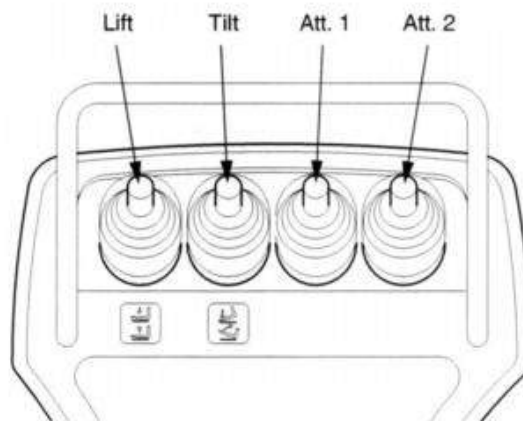

For AOS model (AOS + Fingertip control)

- When lifting the forks up or down with the joysticks, the level number LED lights up or goes off according to the height.
- When lifting the forks up with the joysticks in the lifting height limit mode, the forks automatically stop at the preset height.

2-1-2. Automatic lifting stop operation

- 1 After turning ON the key switch, set the lift to the lowest level.
All the LEDs should not flash.

- When all the LEDs are flashing, the lift is not set to the lowest level after the key switch is turned ON.
- ➔ Lower the forks up to the level where the LEDs do not flash.

- The lift is not set to the lowest level.

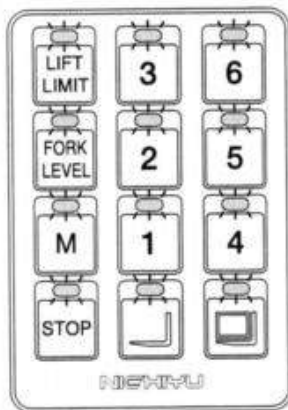

Lifting down

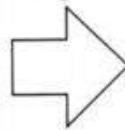

- The lift is set to the lowest level.

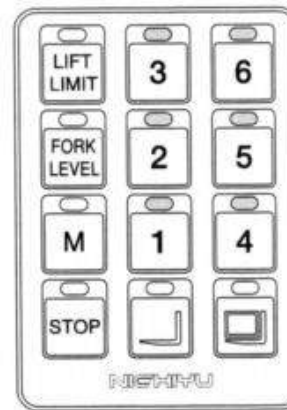

○ : Off
● : On
⚡ : Flashing

* It depends on the memorized stop positions and previous operations.

2011207E

NOTE

When the lift is not set to the lowest level,

- operations with the valve lever and the joystick can be performed.
- automatic lifting stop operation cannot be performed.
- the operation switching for the automatic fork leveling, lifting height limit and A/B rack cannot be performed.
- the stop position cannot be memorized.
- the automatic fork leveling mode and the lifting height limit mode that were set at the end of the previous operation are effective.

2 Check that the LEDs for the level number, where you want to stop the lift automatically, light up.

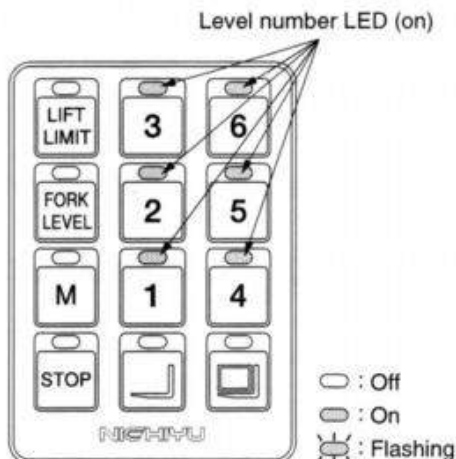

* The figure shows that stop positions are set at 1 - 6 levels.

2211209E

When the LEDs are not lit,

- stop positions have not been stored.
- ➔ Store them (refer to "2-1-6. Storing the stop position" on page 17).
- the lift is positioned above the level where you want to stop it automatically.
- ➔ Lower the lift up to below the level where you want to stop it automatically.
- the lifting height limit mode is selected and the desired level exceeds the limit.
- ➔ Cancel the lifting height limit mode (refer to "2-1-5. Lifting height limit mode switching" on page 16).

3 Press the button for the level number where you want to stop the lift automatically. The LED flashes and the picking and the stacking LEDs are turned on. The stacking LED may not light up depending on the lift's height.

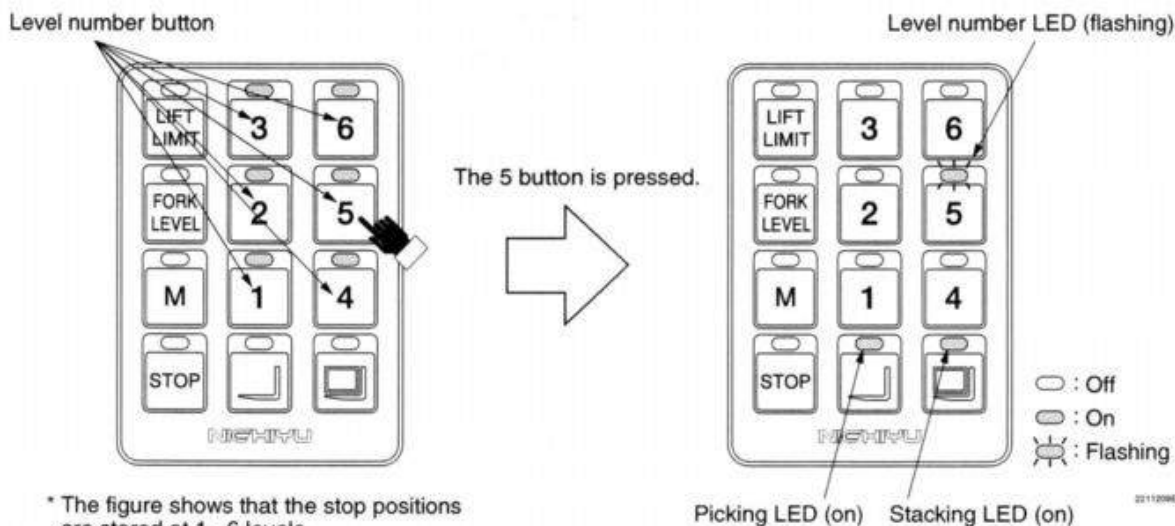

* The figure shows that the stop positions are stored at 1 - 6 levels.

2211209E

4 Press the picking or the stacking button.

The level number LED lights up and the LED for unselected button (either the picking or stacking LED) is turned off.

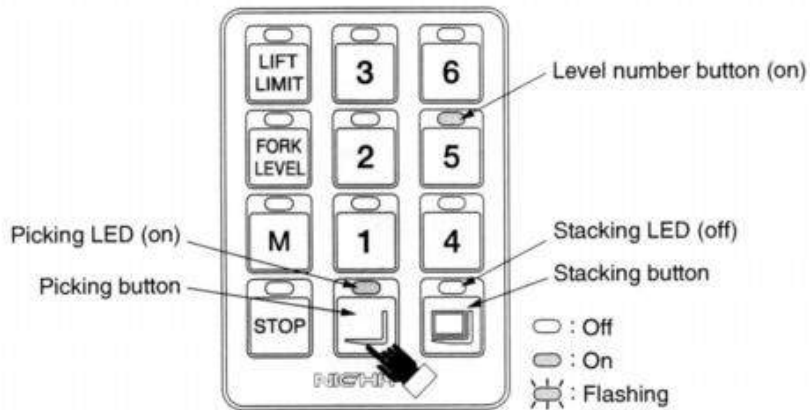

* The figure shows that the picking button is pressed.

22110106

NOTE

If neither the picking nor stacking buttons are pressed for a certain period of time, the operation status automatically returns to 2.

5 The forks are automatically lifted and stopped at the height of the level number that was selected in operation 3. The level number LED and the LED that was selected in operation 4 (either the picking or stacking LED) flash.

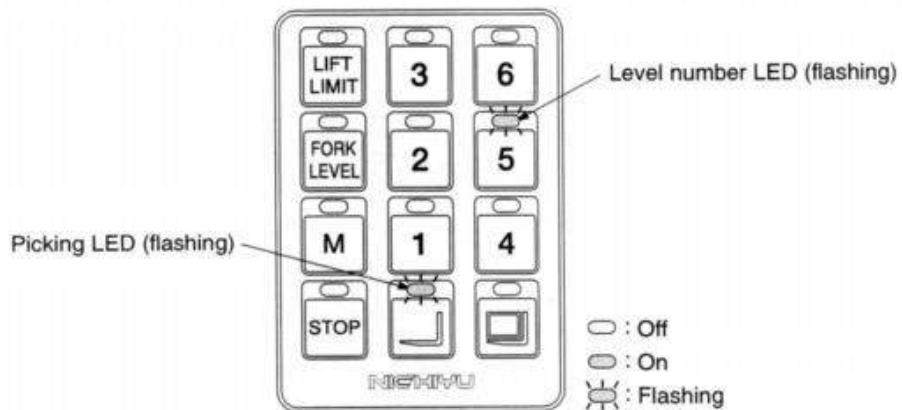

* The figure shows that the picking button is pressed.

22112116

NOTE

- If you operate the valve lever or joystick while in the automatic lifting stop mode, the mode is cancelled.
- If you press the STOP button while in the automatic lifting stop mode, the mode is cancelled and the operation stops.

6 Pick or stack the load.

7 Repeat operations 2 - 6.

2-1-3. Switching the automatic fork leveling mode

- 1 Press the FORK LEVEL button to enter the automatic fork leveling mode.
The LED is turned on.

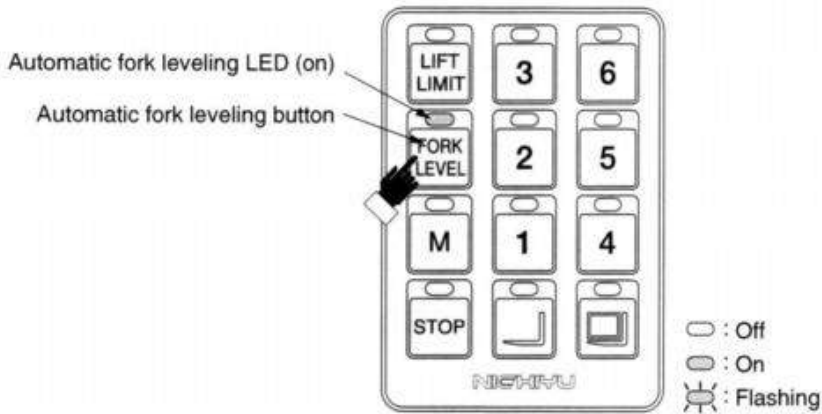

22112126

NOTE

Each time the button is pressed, the automatic fork leveling mode switches between on and off.

- When the LED is not turned on, the fork level position has not been stored.
- ➔ Store the fork level position (refer to "3-1-4. Storing the tilt end/level position").

- 2 Tilt the mast forward or backward with the valve lever or the joystick.
- 3 The mast automatically stops at the preset position where the forks are horizontal.
After the mast stops, the FORK LEVEL LED flashes.

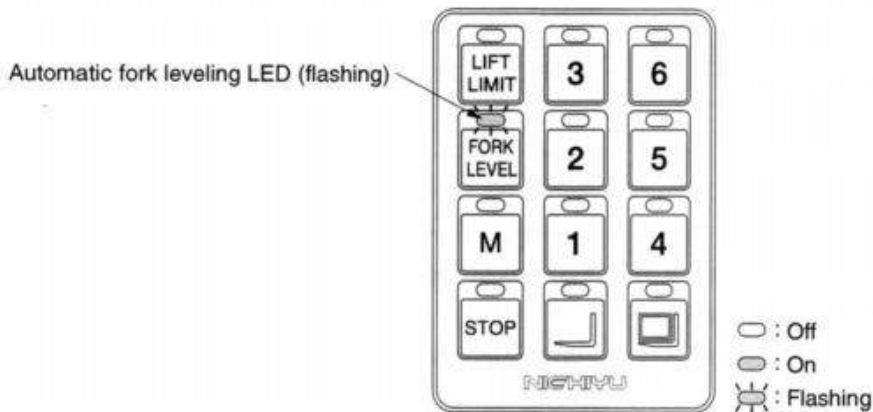

22112126

- 4 Return the valve lever or the joystick to the neutral position.
- 5 Repeat operations 2 - 4.

2-1-4. A/B rack switching

1 Press the A/B button to select the A (the LED is off) or B rack (the LED is on).

NOTE

- Each time the button is pressed, the rack is switched. The level number LED and the LIFT LIMIT LED are turned on or off according to the selected rack.
- The previously stored lifting height limit is applied according to the selected rack.



2211214E

2-1-5. Lifting height limit mode switching

1 Press the LIFT LIMIT button to select the lifting height limit mode.
The LED lights up.

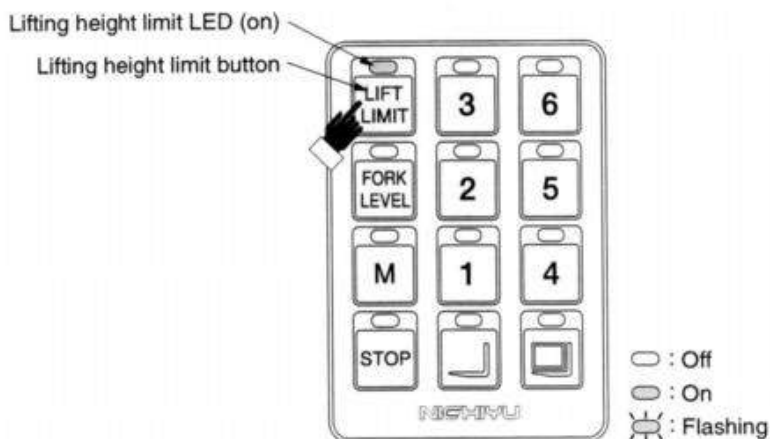

2211215E

NOTE

Each time the button is pressed, the lifting height limit mode switches between on and off.
(When the lifting height limit mode is canceled, the LIFT LIMIT LED is turned off.)

2-1-6. Storing the stop position

A/B rack: For each rack, the automatic lifting stop position and lifting height limit can be stored. In total, 12 automatic lifting stop positions and 2 lifting height limits can be stored.

Automatic fork leveling: In total, 6 automatic lifting stop positions and 1 lifting height limit can be stored.

- 1 Press the M button until the LED is turned on to enter the memory mode.
The LED is turned on by holding down the M button for a few seconds.

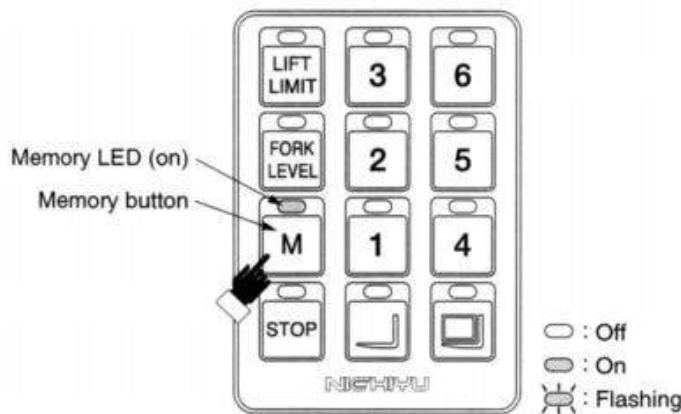

- 2 For a truck with A/B rack, press the A/B button to select the rack.

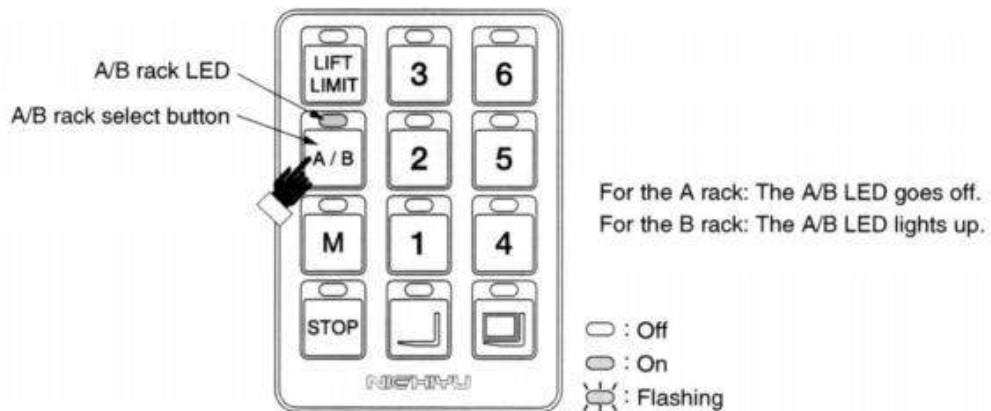

3 Check that the LED of the level number where you want to store the stop position is turned off.

If it is turned off, the stop position has not stored.

Level number LED
(When it lights up, the stop position has been stored.)

Level number LED
(When it goes off, the stop position has not been stored.)

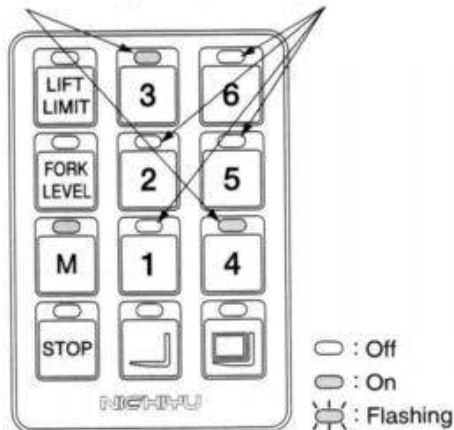

22112176

- When it is turned on, the stop position has been stored.
- ➔ Press down the level number button until the LED goes off.
The previously stored data will be erased.

4 Set the lift with the valve lever or the joystick to the position that you want to store.

- * The position should be the picking height.
- * The stacking height is automatically set where the picking and stacking height distance (50 - 200mm) is added to the picking height. The default distance is 100mm (refer to "3-1-6. Setting the distance of the picking and stacking heights").

5 Press the level number button where you want to memorize the stop position.

The level number LED lights up and the stop position is stored.

Level number LED
(When it lights up, the stop position has been stored.)

Level number LED
(When it goes off, the stop position has not been stored.)

Level number LED (on)

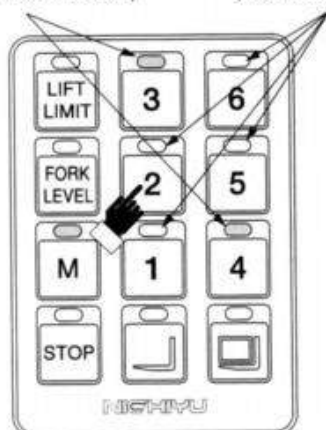

The 2 button is pressed.

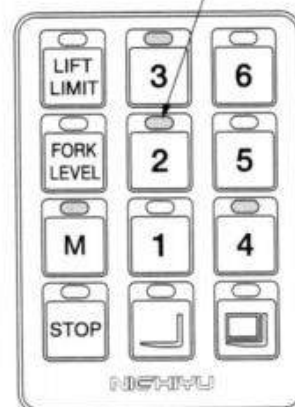
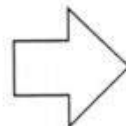

Legend:
 ○ : Off
 ● : On
 ⚡ : Flashing

22112176

When the level number LED is not turned off, "***RACK MISSET***" appears on the monitor display.



2011758

- The lift is positioned above the lift end (maximum) height (as for the lift end, refer to "3-1-5. Storing the lift end" on page 30).
 ➔ Lower the lift up to below the lift end (maximum) position.
- The lift is positioned above the registered level.
 [Ex.]: The registered level number is 3 and the lift is positioned at one of the 4 - 6 levels.
 ➔ Lower the lift up to the stored level or below.
- The lift is positioned below the registered level.
 [Ex.]: The registered level number is 3 and the lift is positioned at either 1 or 2 level.
 ➔ Raise the lift up to the stored level or above.

6 Check that the LIFT LIMIT LED is turned off.
 If it is turned off, the lifting height limit has not been stored.

Lifting height limit LED (off)



2011286

- When it is not turned off, the lifting height limit has already been stored.
 ➔ Press down the LIFT LIMIT button until the LED is turned off. The data is erased.

7 Set the lift with the valve lever or the joystick to the position where you want to register the lifting height limit.

8 Press the LIFT LIMIT button.
The LED lights up and the limit is stored.

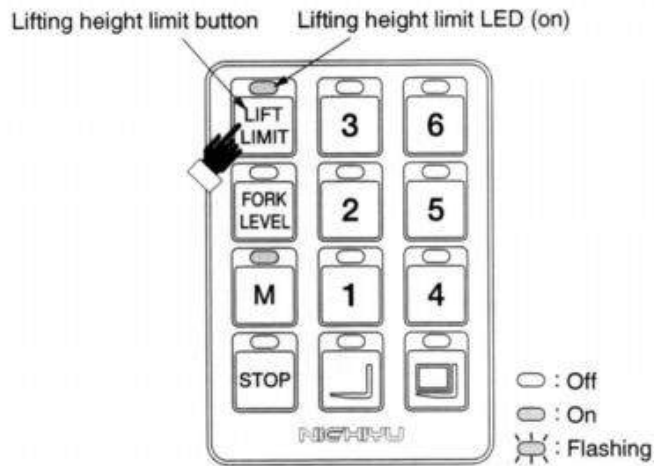

2211220E

9 Repeat operations 3 - 8.

10 Press the M button.
The LED lights up and the memory mode is cancelled.

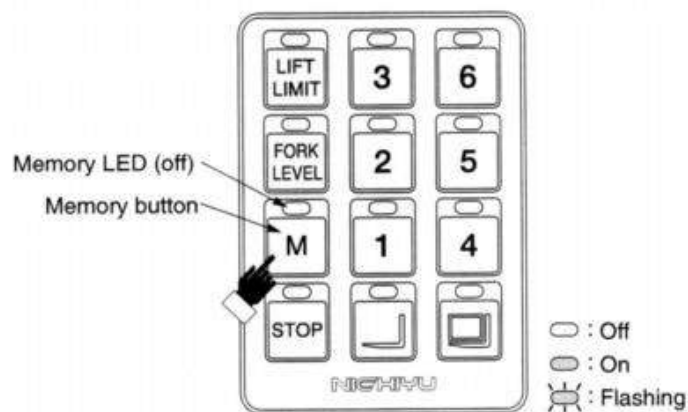

2211245E

2-1-7. Stop (emergency stop) operation

- 1 Press the STOP button during the valve lever, joystick, or the automatic lifting stop operation.
The LED lights up.

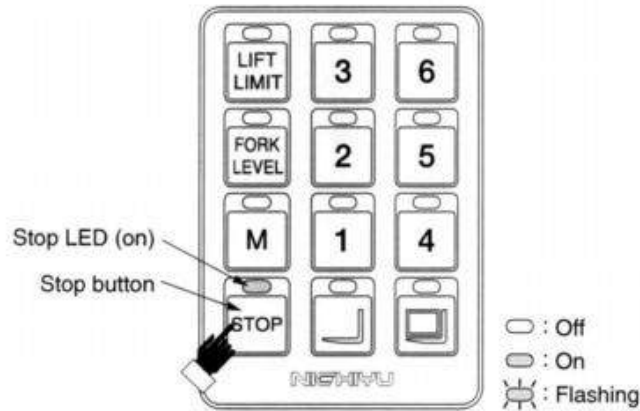

2211221E

- 2 The operation is stopped.
" *AOS FAIL OPERATION* " appears on the monitor display.

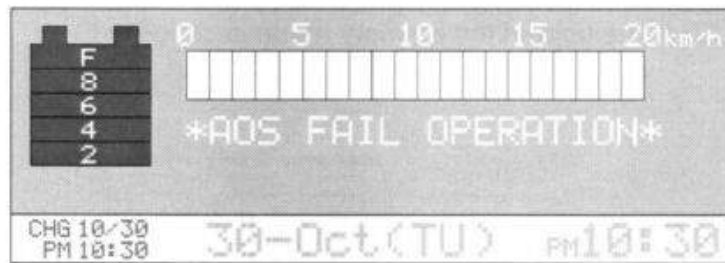

221176E

- 3 Return the valve lever or the joystick to the neutral position and wait for a certain period of time (approx. 5 seconds).
- 4 The emergency stop is cancelled.
The LED goes off.

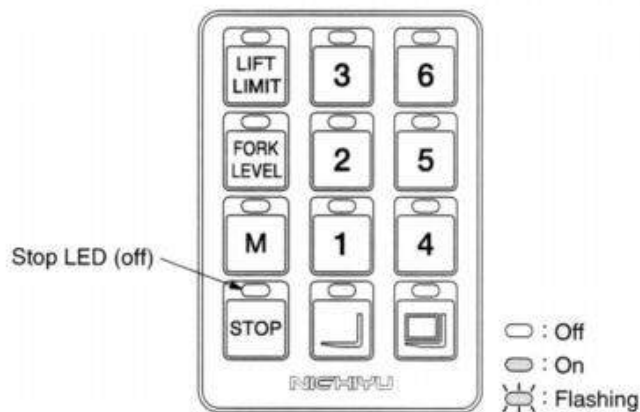

2211222E

3. ADJUSTMENTS OF TRUCK WITH PROPORTIONAL CONTROL VALVE

3- 1. Adjustments

<Adjustments list>

[Spec. 1]: AOS
 [Spec. 2]: AOS + Fingertip control
 [Spec. 3]: Fingertip control

○ : mandatory adjustments (Numbers indicate the adjustment order.)

△ : adjustments based on user demand

RS1	Item	Specification	[Spec. 1] or [Spec. 2]		[Spec. 3]
			Automatic fork leveling	A/B rack	
6	3-1-1. Memory clear	P.23	①	①	
	3-1-2. Optional setting	P.24 - P.26	②	②	①
C	3-1-3. Adjusting the potentiometer for tilting angle detection	P.27	⑤		
	3-1-4. Storing the tilt end/level position	P.28, P.29	⑥		
	3-1-5. Storing the lift end	P.30 - P.32	⑦	⑤	
	3-1-6. Setting the distance of the picking and stacking heights	P.33, P.34	△	△	
	3-1-7. Lift end speed reduction setting	P.35, P.36	△	△	
	3-1-8. Tilt end speed reduction setting	P.37, P.38	△	△	
	3-1-9. Switching of fork leveling and A/B rack	P.39, P.40	⑧	⑥	
D	3-1-10. Lever potentiometer adjustment	P.41, P.42	③	③	②
	3-1-11. Solenoid valve current adjustment	P.43, P.44	④	④	③

* RS 1: rotary switch on the display board

* If "3-1-2. Optional setting" is not performed, "C" and "D" of RS 1 are disabled.

3-1-1. Memory clear

- 1 Set rotary switch RS1 on the display board to "6".
- 2 Turn the key switch ON and the following screen appears.

• Display board

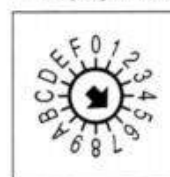

Set RS1 to "6".

- Option setting screen

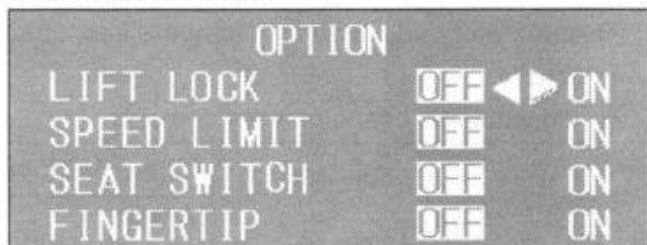

201177

- 3 Press the **(R)** button repeatedly to select "AOS".

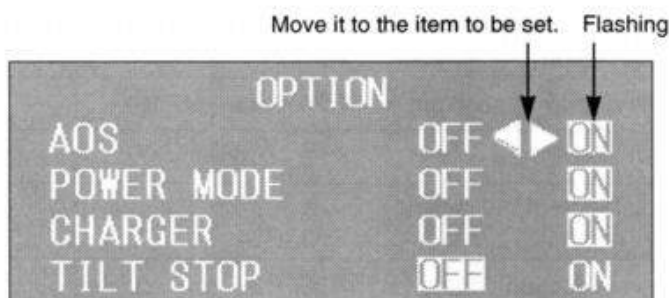

201178

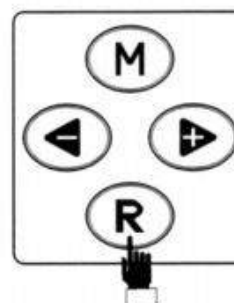

- * When "OFF" is selected for the AOS option, press the **(▶)** button to select "ON".

- 4 Press the **(◀)** button to select "OFF".

The AOS memory is cleared and parameters return to default.

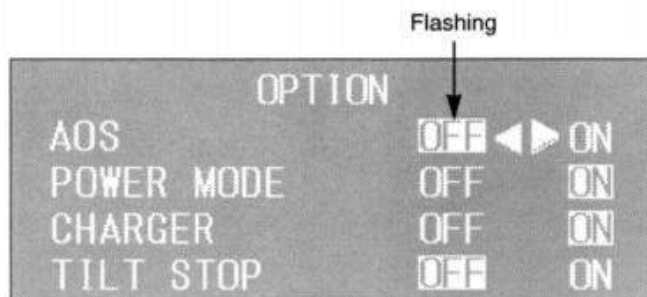

201179

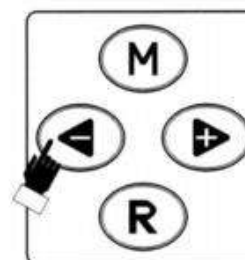

- When "OFF" cannot be selected, the display board and travel/hydraulic board cannot communicate with each other.

➔ Check for the breaking of wire.

3-1-2. Optional setting

- 1 Set rotary switch RS1 on the display board to "6".
- 2 Turn the key switch ON and the following screen appears.

• Display board

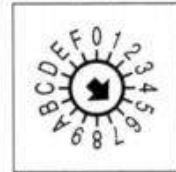

Set RS1 to "6".

• Option setting screen

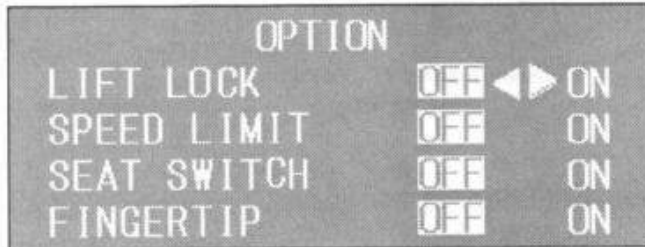

221177

- 3 Press the **R** button to select "SPEED LIMIT".

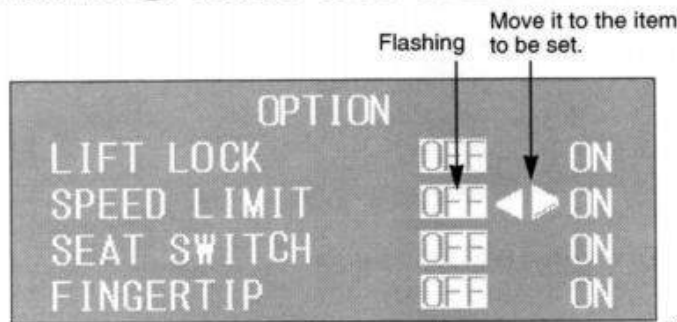

221180

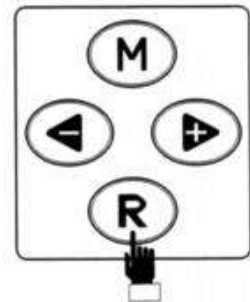

- 4 For the AOS model ([Spec. 1] and [Spec. 2]), press the **▶** button to select "ON".

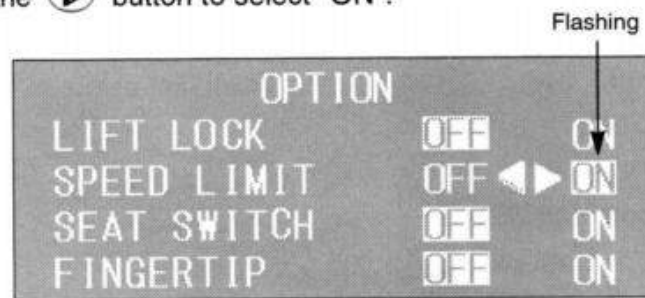

221181

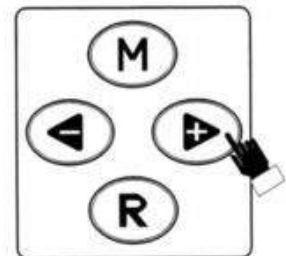

If "ON" is selected, the traveling speed is limited according to the lifting height (the same as when the turtle switch is turned on).

(Refer to "3-3. Speed limit at high lifting height" on page 47 for the traveling speed limit.)

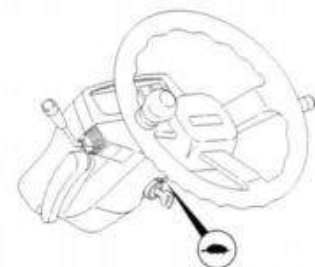

turtle switch

221172

- When "ON" cannot be selected, the display board and travel/hydraulic board cannot communicate with each other.

➔ Check for the breaking of wire.

5 Press the **R** button twice to select "FINGERTIP".

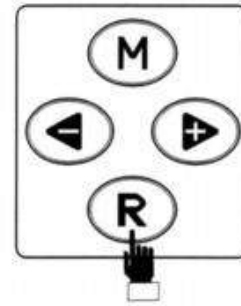
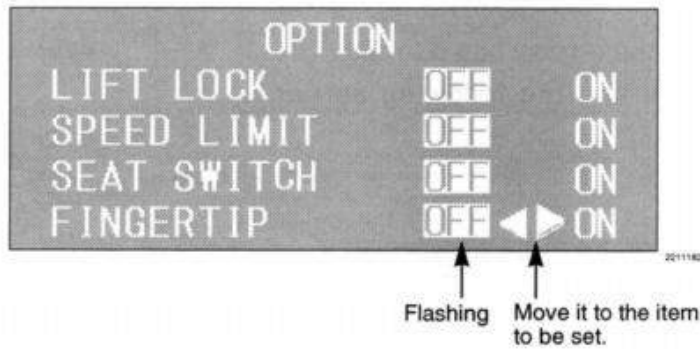

6 For the fingertip control model ([Spec. 2] and [Spec. 3]), press the **▶** button to select "ON".

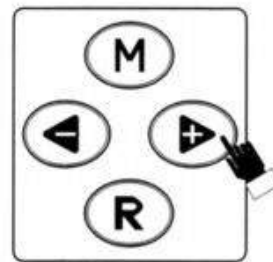
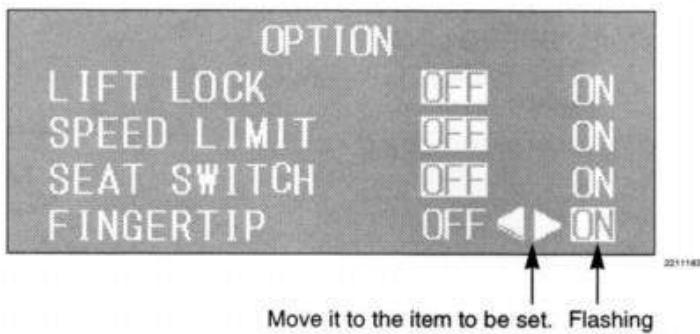

- When "ON" cannot be selected, the display board and travel/hydraulic board cannot communicate with each other.

➔ Check for the breaking of wire.

7 Press the **R** button to select "AOS".

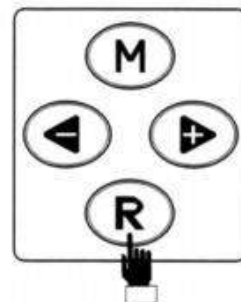
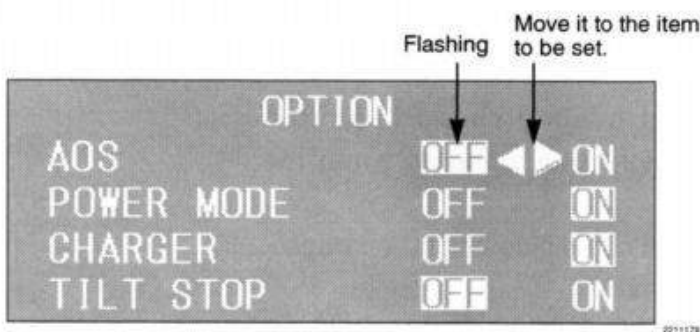

- 8] For the AOS model ([Spec. 1] and [Spec. 2]), press the  button to select "ON".

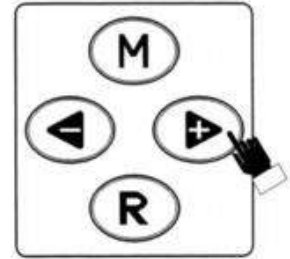
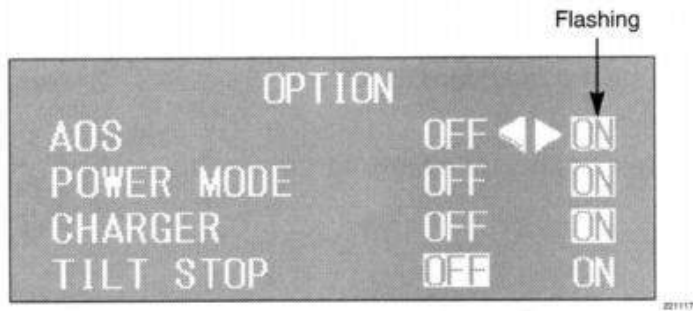

- When "ON" cannot be selected, the display board and travel/hydraulic board cannot communicate with each other.
- ➔ Check for the breaking of wire.

3-1-3. Adjusting the potentiometer for tilting angle detection

1 Set rotary switch RS1 on the display board to "C".

2 Turn the key switch ON and the following screen appears.

• AOS setting screen

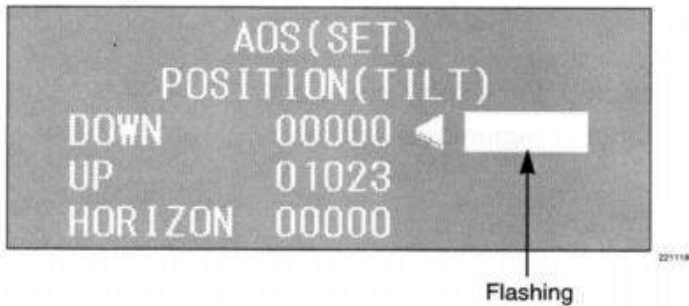

• Display board

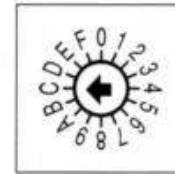

Set RS1 to "C".

3 After a few seconds, the parameter for tilt potentiometer starts flashing.

4 Check that all the LEDs for the AOS switch are flashing.

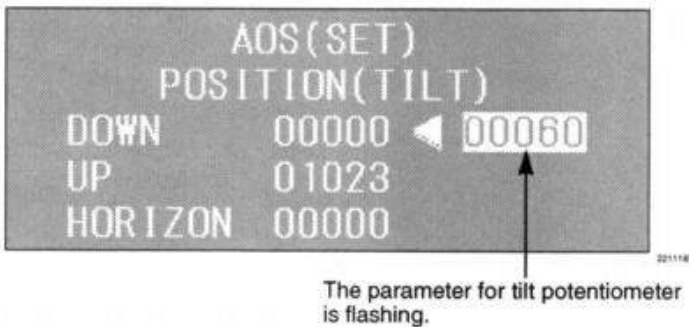

• AOS switch

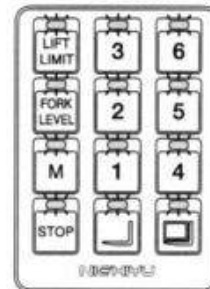

⚡: Flashing

All the LEDs are flashing.

• When the parameter for tilt potentiometer is not displayed, the display board and travel/hydraulic board cannot communicate with each other.

➔ Check for the breaking of wire.

5 Using the valve lever or the joystick, set the rod of the potentiometer to detect the tilting angle to the value below.

When the mast is tilted forward fully	Parameter for tilt potentiometer ≥ 40
When the mast is tilted backward fully	Parameter for tilt potentiometer ≤ 980

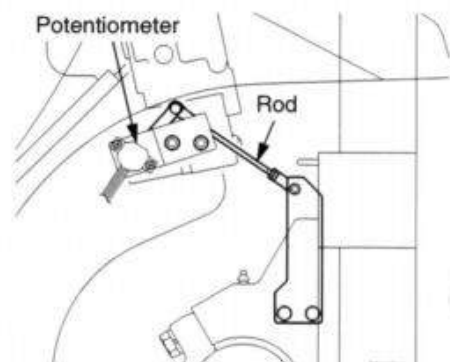

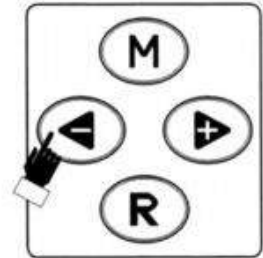
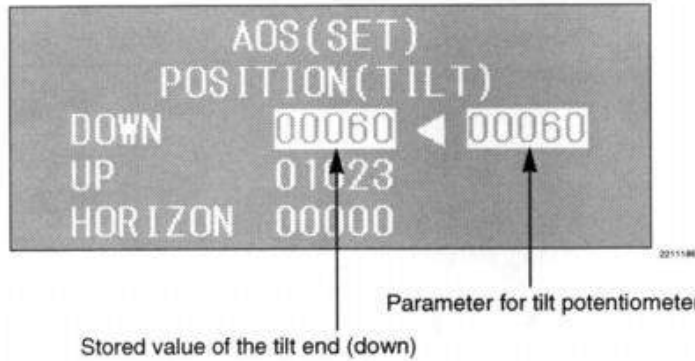

3-1-4. Storing the tilt end/level position

- 1 After operations in "3-1-3. Adjusting the potentiometer for tilting angle detection" are completed, tilt the mast forward fully with the valve lever or the joystick.
- 2 Press the  button to store the tilt end (down) ["POSITION (TILT)/DOWN"].

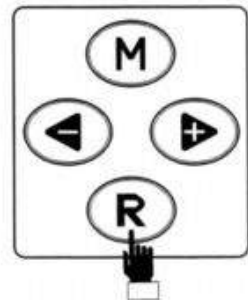
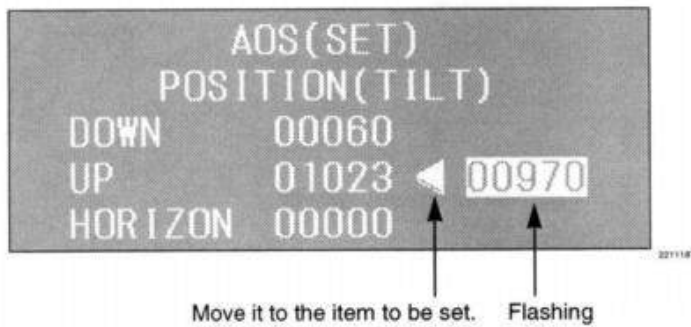

- 3 Using the valve lever or the joystick, tilt the mast backward fully.
- 4 Press the  button to select "POSITION (TILT)/UP".



- 5 Press the  button to store the tilt end (up).

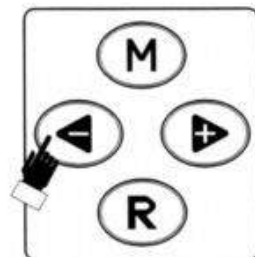
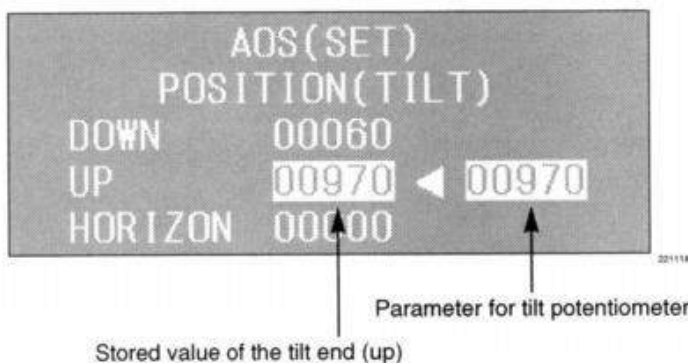

6 Adjust the mast with the valve lever or the joystick so that the forks are in the horizontal position.

NOTE

Using the level vial, check that the upper face of the forks without loads is horizontal.

7 Press the **R** button to select "POSITION (TILT)/HORIZON".

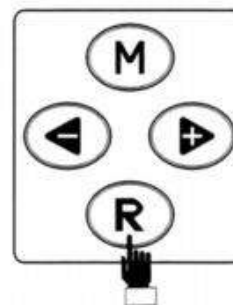
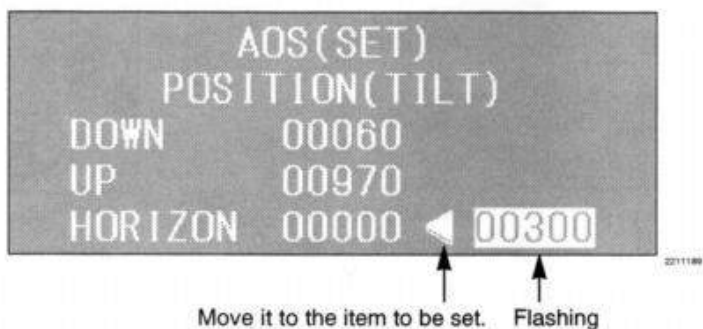

8 Press the **◀** button to store the fork level position.

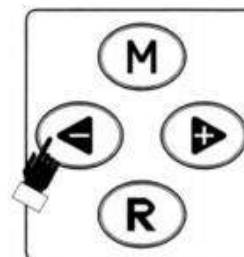
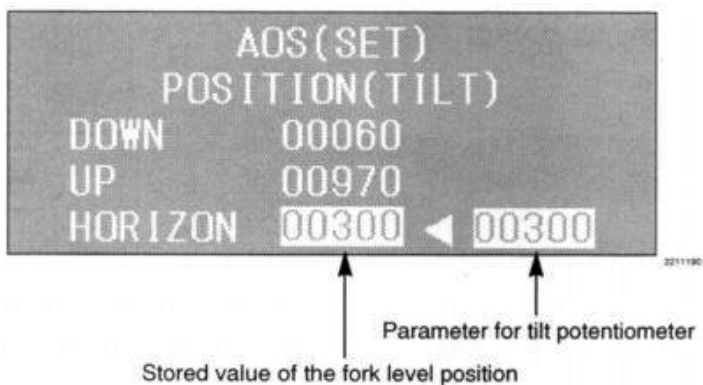

3-1-5. Storing the lift end

- 1 Set rotary switch RS1 on the display board to "C".
- 2 Turn the key switch ON and the following screen appears.

• Display board

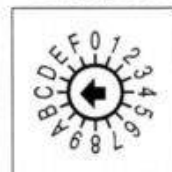

Set RS1 to "C".

- AOS setting screen



Flashing

- 3 After a few seconds, the parameter for tilt potentiometer starts flashing.
- 4 Check that all the LEDs for the AOS switch are flashing.

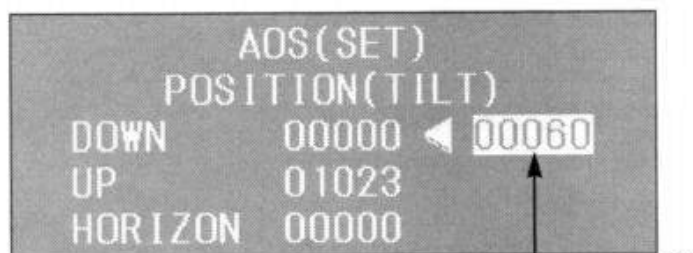

The parameter for tilt potentiometer is flashing.

• AOS switch

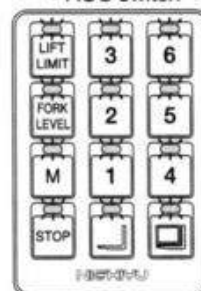

⚡: Flashing

All the LEDs are flashing.

- When the parameter for tilt potentiometer is not displayed, the display board and the travel/hydraulic board cannot communicate with each other.
- ➔ Check for the breaking of wire.

- 5 Press the **R** button repeatedly to select "POSITION (LIFT)/DOWN".

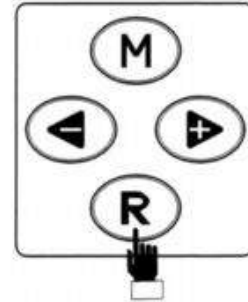
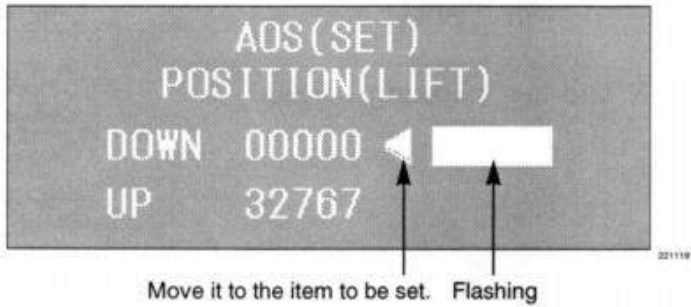

- 6 Lower the lift up to the lowest level with the valve lever or the joystick.

- 7 Check that the parameter for lift encoder is flashing.

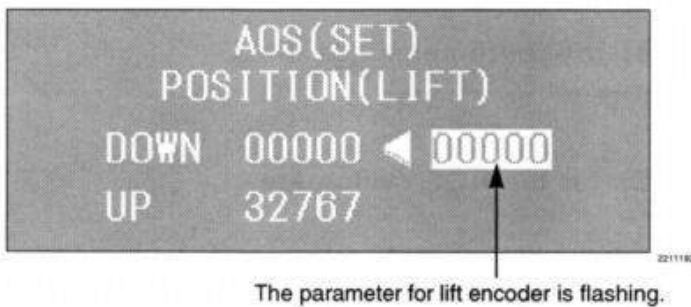

The parameter for lift encoder is flashing.

When the parameter for lift encoder is not displayed,

- the setting for lift lowest level has not completed.
 - ➔ Lower the lift up to the lowest level.
 - ➔ Check that the wire of the limit switch for setting the lift lowest level is not broken.
- the display board and the travel/hydraulic board cannot communicate with each other.
 - ➔ Check for the breaking of wire.

- 8 Press the **←** button to store the lift end (down).

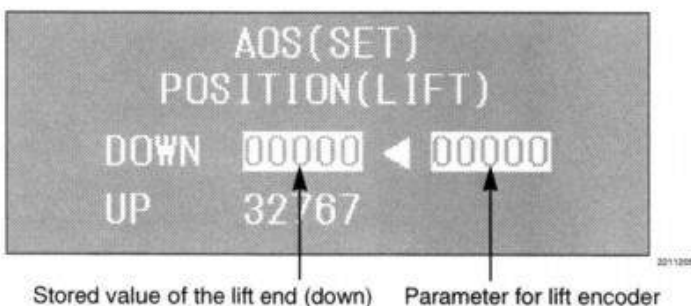

Stored value of the lift end (down) Parameter for lift encoder

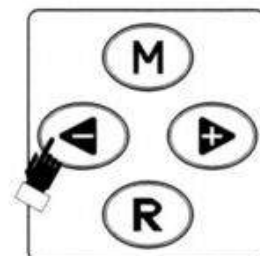

9] Raise the lift up to the highest level with the valve lever or the joystick.

10] Press the **(R)** button to select "POSITION (LIFT) /UP".

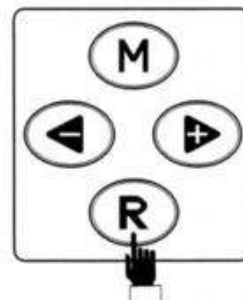
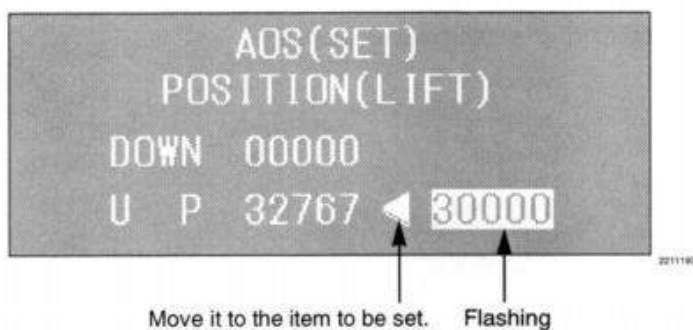

11] Press the **(◀)** button to store the lift end (up).

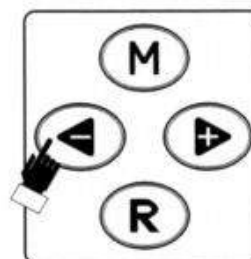
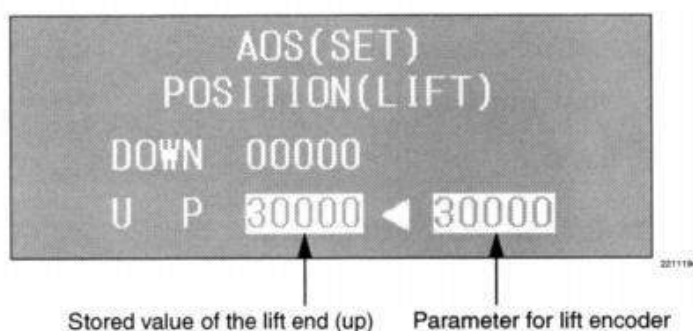

3-1-6. Setting the distance of the picking and stacking heights

- 1 Set rotary switch RS1 on the display board to "C".
- 2 Turn the key switch ON and the following screen appears.

• Display board

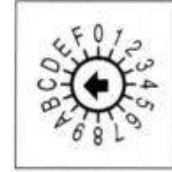

Set RS1 to "C".

• AOS setting screen

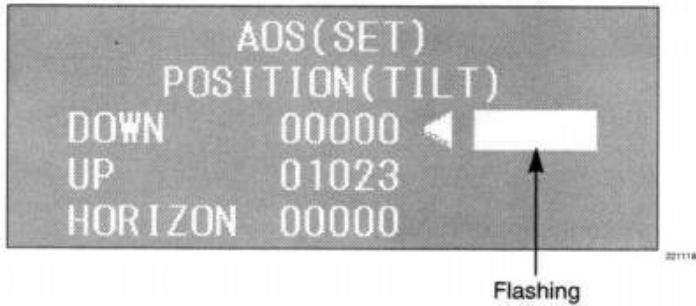

- 3 After a few seconds, the parameter for tilt potentiometer starts flashing.
- 4 Check that all the LEDs for the AOS switch are flashing.



The parameter for tilt potentiometer is flashing.

• AOS switch

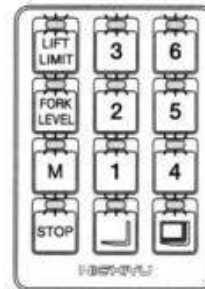

⚡: Flashing

All the LEDs are flashing.

- When the parameter for tilt potentiometer is not displayed, the display board and the travel/hydraulic board cannot communicate with each other.
- ➔ Check for the breaking of wire.

- 5 Press the **(R)** button repeatedly to select "DISTANCE".

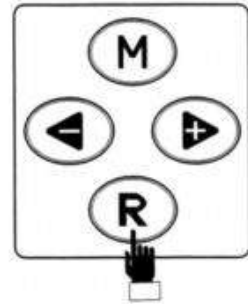
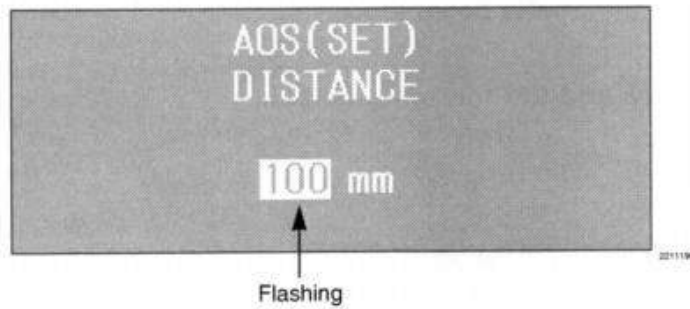

- 6 Press the **(←)** or **(→)** button to adjust the parameter (50 - 200mm).

- Press the **(→)** button to increase the parameter.
- Press the **(←)** button to decrease the parameter.

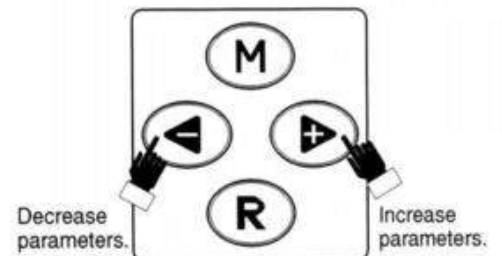
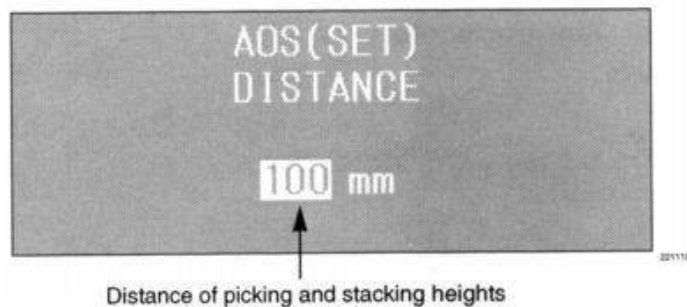

3-1-7. Lift end speed reduction setting

1 Set rotary switch RS1 on the display board to "C".

2 Turn the key switch ON and the following screen appears.

• AOS setting screen

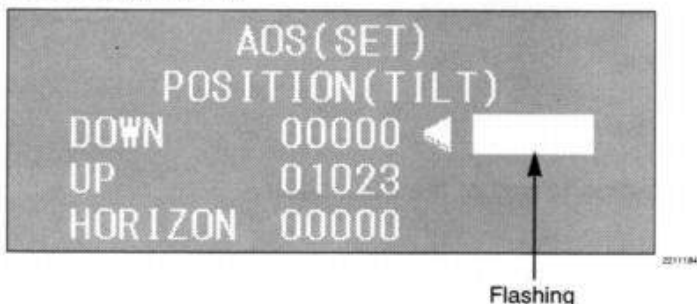

• Display board

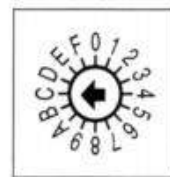

Set RS1 to "C".

3 After a few seconds, the parameter for tilt potentiometer starts flashing.

4 Check that all the LEDs for the AOS switch are flashing.

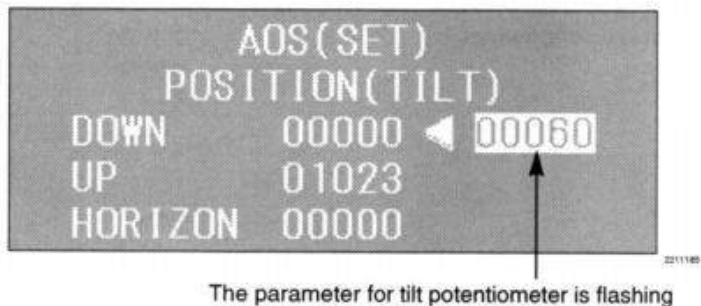

• AOS switch

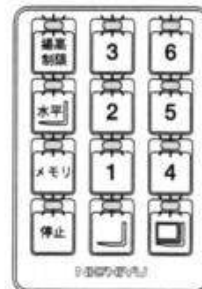

All the LEDs are flashing.

⚡ : Flashing

• When the parameter for tilt potentiometer is not displayed, the display board and the travel/hydraulic board cannot communicate with each other.

➡ Check for the breaking of wire.

5 Press the **R** button repeatedly to select "SLOWDOWN/LIFT".

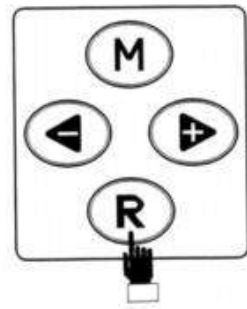
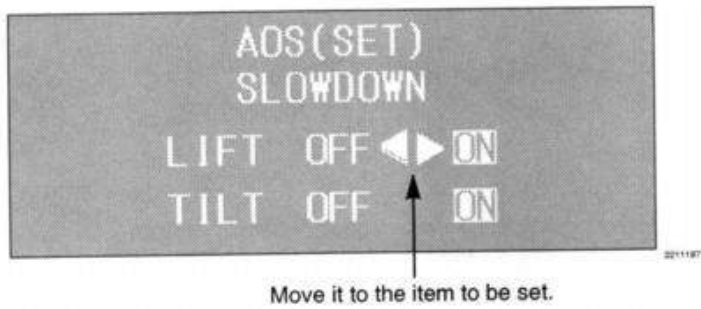

6 Press the ◀ or ▶ button to turn ON or OFF the setting.

- When the ▶ button is pressed, the setting is turned ON.
- When the ◀ button is pressed, the setting is turned OFF.

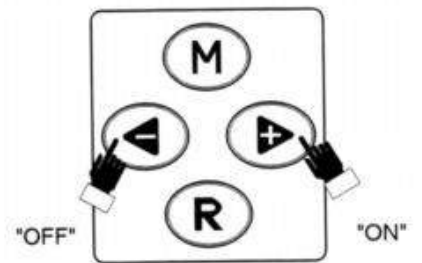
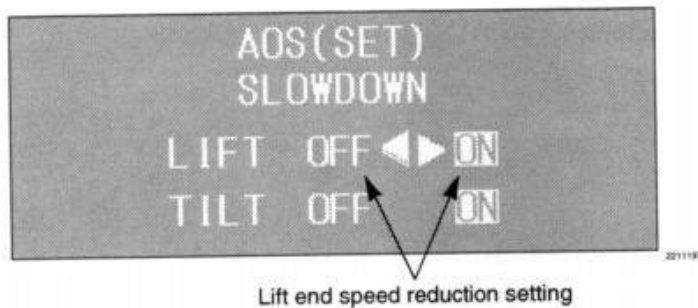

3-1-8. Tilt end speed reduction setting

- 1 Set rotary switch RS1 on the display board to "C".
- 2 Turn the key switch ON and the following screen appears.

• AOS setting screen

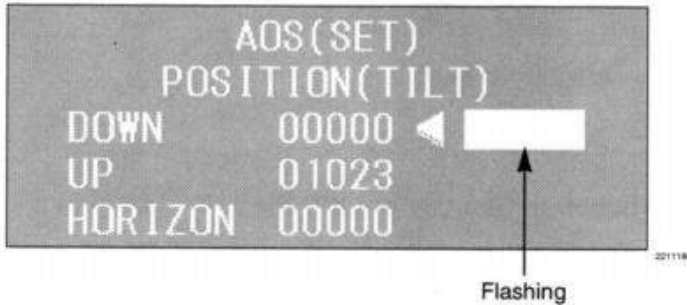

• Display board

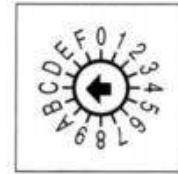

Set RS1 to "C".

- 3 After a few seconds, the parameter for tilt potentiometer starts flashing.

- 4 Check that all the LEDs for the AOS switch are flashing.



The parameter for tilt potentiometer is flashing.

• AOS switch

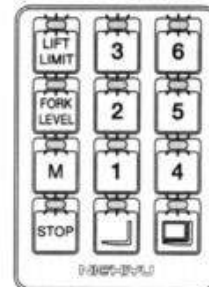

⚡: Flashing

All the LEDs are flashing.

- When the parameter for tilt potentiometer is not displayed, the display board and the travel/hydraulic board cannot communicate with each other.

➔ Check for the breaking of wire.

- 5 Press the **R** button repeatedly to select "SLOWDOWN/TILT".

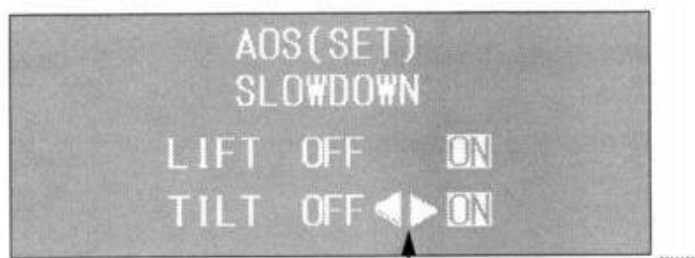

Move it to the item to be set.

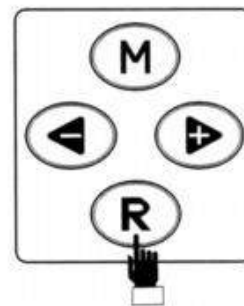

- 6 Press the **◀** or **▶** button to turn on or off the setting.

- Pressing the **▶** button turns ON the setting.
- Pressing the **◀** button turns OFF the setting.

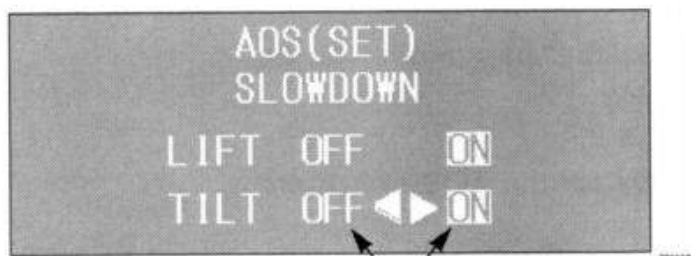

Tilt end speed reduction

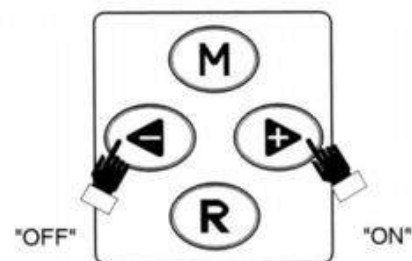

3-1-9. Switching of fork leveling and A/B rack

1 Set rotary switch RS1 on the display board to "C".

2 Turn the key switch ON and the following screen appears.

• Display board

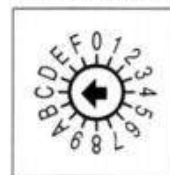

Set RS1 to "C".

• AOS setting screen

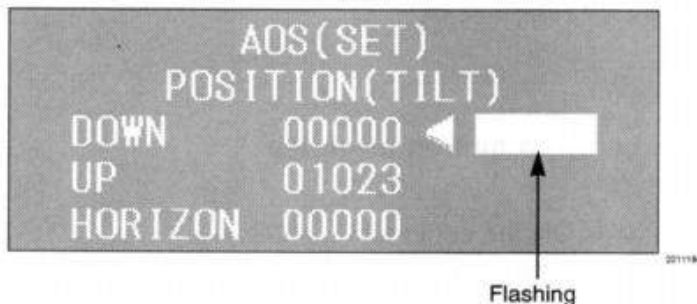

3 After a few seconds, the parameter for tilt potentiometer starts flashing.

4 Check that all the LEDs for the AOS switch are flashing.

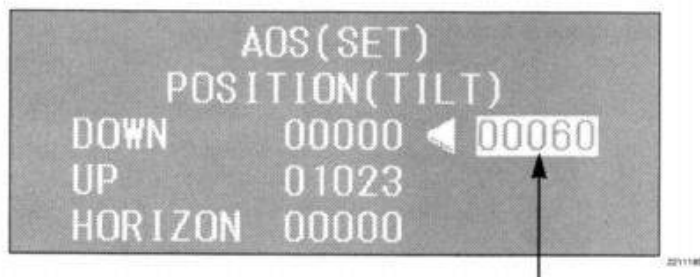

The parameter for tilt potentiometer is flashing.

• AOS switch

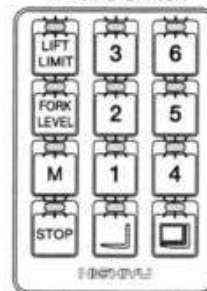

⚡: Flashing

All the LEDs are flashing.

• When the parameter for tilt potentiometer is not displayed, the display board and the travel/hydraulic board cannot communicate with each other.

➔ Check for the breaking of wire.

- 5 Press the **R** button repeatedly to select "SW FUNCTION".

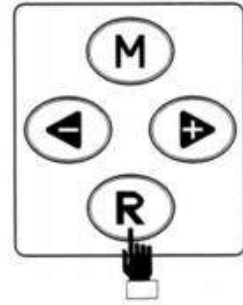
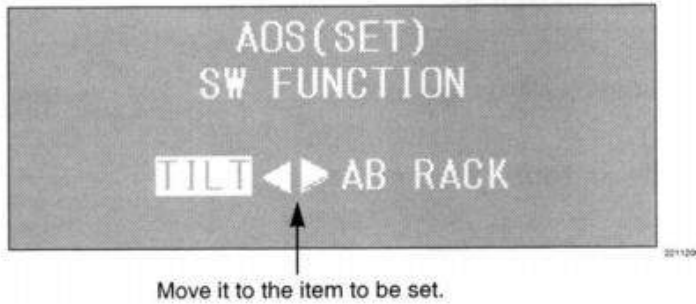

- 6 Press the ◀ or ▶ button to select "TILT" or "AB RACK".

- Press the ▶ button to select "AB RACK".
- Press the ◀ button to select "TILT".

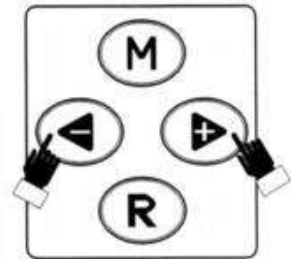
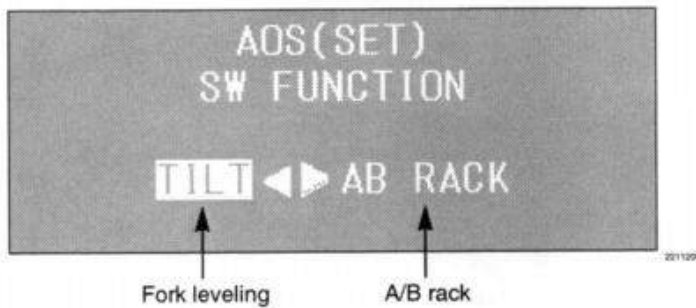

3-1-10. Lever potentiometer adjustment

Adjustment by the display

- 1 Set rotary switch RS1 on the display board to "D".
- 2 Turn the key switch ON and the following screen appears.

• AOS inspection screen

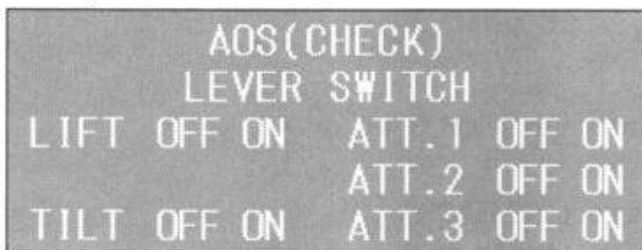

0211001

• Display board

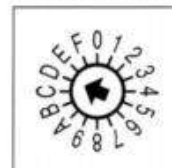

Set RS1 to "D".

- 3 After a few seconds, the status of all the lever switches is highlighted.

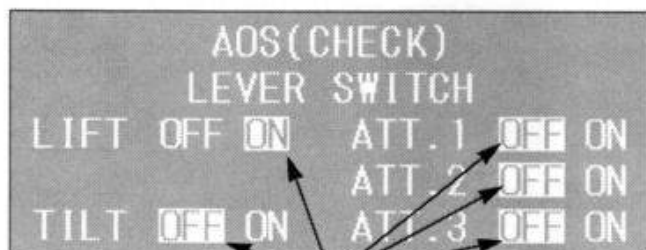

0211002

Status of the lever switch

CAUTION

• Never operate the potentiometer, the valve lever and the joystick before the status of all the lever switches is highlighted.
 ➔ The hydraulic system is activated.

- When the status of the lever switch is not highlighted, the display board and the travel/hydraulic board cannot communicate with each other.
- ➔ Check for the breaking of wire.

- 4 While setting all the valve levers or the joysticks to the neutral position, adjust the potentiometer to highlight all the "OFF" displays.

Even if the levers or the joysticks are in the free play area for the neutral position, "OFF" should be highlighted.

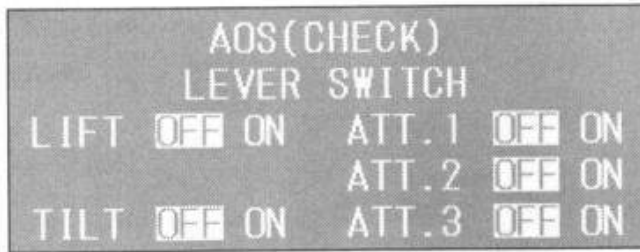

Adjustment by the tester

- 1 Turn the key switch OFF and disconnect the potentiometer.
- 2 Check that the electric conductivity between the black and the red/black wires of the potentiometer with the tester.

CAUTION

- The tester should not come into contact with other terminals.
- ➔ The resistance in the potentiometer may be broken.

- 3 While setting all the valve levers or the joysticks to the neutral position, adjust the potentiometer so that the electricity is not conducted. Even if the levers or joysticks are in the free play area for the neutral position, the electricity should not be conducted.

- 4 To protect the resistance in the potentiometer, put a resistance of $1\text{ k}\Omega$ between the tester and the potentiometer in advance.

- 5 While operating the valve lever or the joystick, check that the resistance is the value below.

Position of the lever or joystick	Resistance
Fully pushed forward	$1.09\text{ k}\Omega$ or less
Fully pulled back	$1.91\text{ k}\Omega$ or less

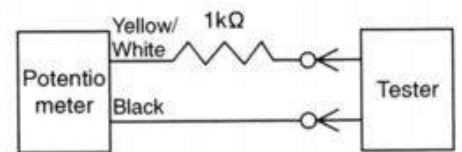
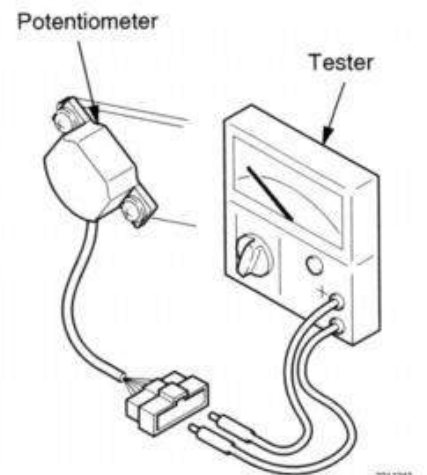

3-1-11. Solenoid valve current adjustment

- 1 Set rotary switch RS1 on the display board to "D".
- 2 Turn the key switch ON and the following screen appears.

• Display board

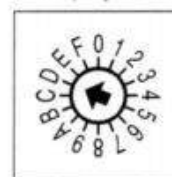

Set RS1 to "D".

• AOS inspection screen

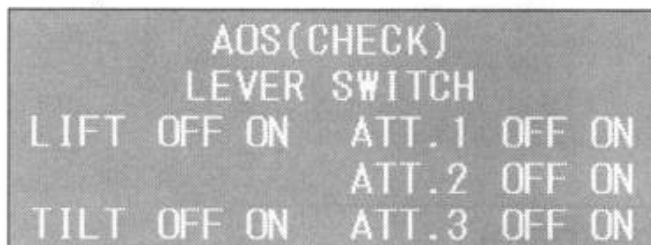

2011201

- 3 After a few seconds, the status of all the lever switches is highlighted.

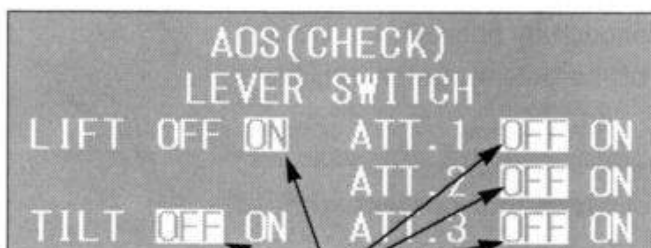

2011202

Status of the lever switch

CAUTION

- Never operate the potentiometer, the valve lever and the joystick before the status of all the lever switches is highlighted.
- ➔ The hydraulic system is activated.

- When the status of the lever switch is not highlighted, the display board and the travel/hydraulic board cannot communicate with each other.
- ➔ Check for the breaking of wire.

- 4 While pushing forward or pulling back fully all the valve levers or the joysticks, adjust the volume on the travel/hydraulic board so that the electric current to the solenoid valve is $0.70 \pm 0.02A$.

<Measuring point>

Solenoid valve current

<Measuring instrument>

Clamp ammeter

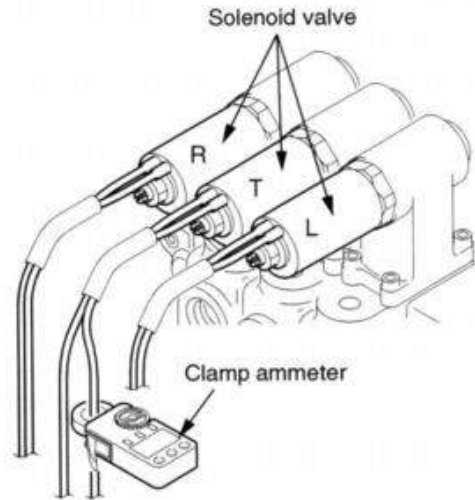

221047

• Travel / Hydraulic board

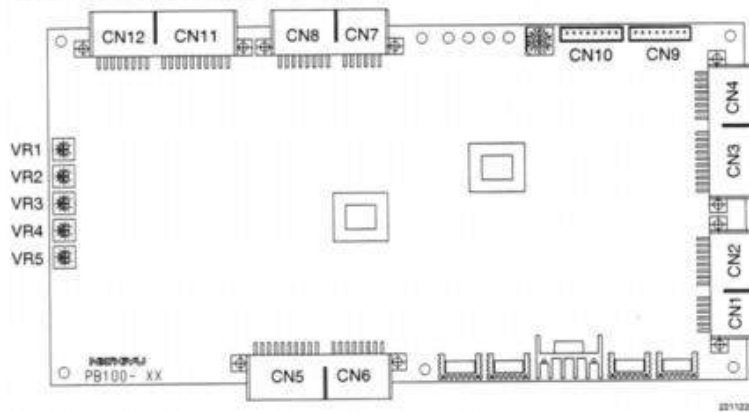

Volume	Solenoid valve
VR1	—
VR2	ATT. 2
VR3	ATT. 1
VR4	Tilt
VR5	Lift

2211229

3-2. Final check

- 1 After all the adjustments are completed, turn the key switch OFF
- 2 Return the rotary switch RS1 to "0".
- 3 For the AOS model ([Spec. 1] and [Spec. 2]), turn the key switch ON again and check the following (3-2-1, 3-2-2 and 3-2-3).

• Display board

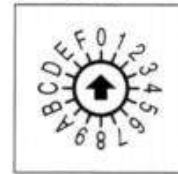

Return RS1 to "0".

3-2-1. Checking the accuracy of automatic lifting stop

- 1 While no loads are stacked on the lift, store the stop position.
(Refer to "2-1-6. Storing the stop position" on page 17.)
- 2 Perform the automatic lifting stop operation with and without loads and check that the automatic lifting stop position is within the value below.
(Refer to "2-1-2. Automatic lifting stop operation" on page 12.)

Automatic lifting stop position	Stored position \pm 10mm
---------------------------------	----------------------------

- Automatic lifting stop position > Stored position + 10mm
➔ Adjust the stored position lower.
- Automatic lifting stop position < Stored position - 10mm
➔ Adjust the stored position higher.

3-2-2. Checking the accuracy of automatic fork leveling

- 1 Engage the automatic fork leveling mode.
(Refer to "2-1-3. Switching the automatic fork leveling mode" on page 15.)
- 2 Move the mast from the fully anteverted position to the fully retroverted position, and vice versa. When the forks stop in the horizontal position, check that the drift of tilt is within the value below.

Drift of tilt	$\pm 2^\circ$
---------------	---------------

- Drift of tilt $> +2^\circ$
➔ Adjust the fork stop position downward a little
- Drift of tilt $< -2^\circ$
➔ Adjust the fork stop position upward a little.

3-2-3. Checking the solenoid valve current

- 1 With no loads stacked on the lift, store the stop position.
(Refer to "2-1-6. Storing the stop position" on page 17.)
 - 2 Perform the automatic lifting stop operation with and without loads, and check that the forks stop smoothly.
(Refer to "2-1-2. Automatic lifting stop operation" on page 12.)
- When the lift does not stop smoothly, adjust the solenoid valve current.

3- 3. Speed limit at high lifting height

Lift height [mm]		Speed limit [km/h]	
1273 + L	-	5	
1179 + L	-	1273 + L	6
1084 + L	-	1179 + L	7
990 + L	-	1084 + L	8
896 + L	-	990 + L	9
802 + L	-	896 + L	10
707 + L	-	802 + L	11
613 + L	-	707 + L	12
519 + L	-	613 + L	13
424 + L	-	519 + L	14
330 + L	-	424 + L	15
	-	330 + L	No limitation

* L: Lifting height where the limit switch for the lowest level is turned on

Model		L [mm]
FB10 - 15P	FBB15P	490
FB20 / 25 /28P	FBB20 / 25P	502
FB30P	FBB30P	603

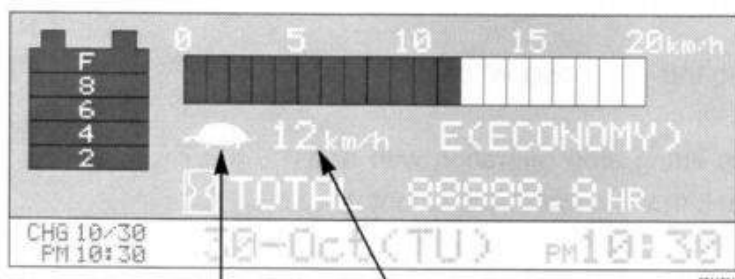

Speed limit at high lifting height (lights up when the turtle switch is turned OFF.)

Reduced speed according to the lifting height

NOTE

When the speed limit at high lifting height operation, the speed limit at turning operation and the turtle switch are simultaneously activated, the slowest speed limit is adopted.

Reproduction prohibited

First printing : March 2002

Issued by : Nippon Yusoki Co., Ltd

Edited by : Overseas division
Nippon Yusoki Co., Ltd.