

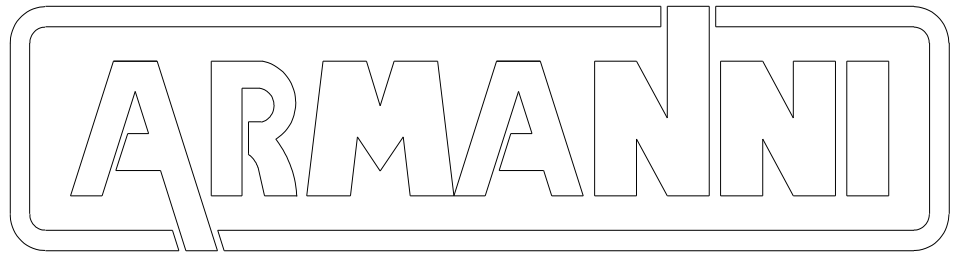

FORKLIFT
CP LIGHTevo030.con
PINZA BECCO

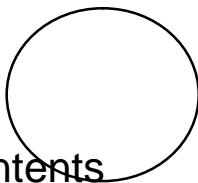

MANUALE DI ISTRUZIONI



Contents

Chapter 1 **G**eneral information 1-1

1.1	Available documentation	1-1
	1.1.1 This handbook.....	1-1
1.2	Information ownership.....	1-1
1.3	Manufacturer's identification data.....	1-2
1.4	Machine identification data.....	1-2
1.5	CE conformity statement.....	1-3
1.6	General safety instructions.....	1-3
	1.6.1 Passive safety devices.....	1-4
	1.6.2 Active safety devices.....	1-4
	1.6.3 Personnel qualification.....	1-4
	1.6.4 Danger zones.....	1-5
	1.6.5 Machine danger zones during use and maintenance.....	1-5
	1.6.6 Personal protections.....	1-6
1.7	Uses foreseen.....	1-6
	1.7.1 Operations foreseen.....	1-6
	1.7.2 Installation modalities foreseen.....	1-6
	1.7.3 Operation modalities foreseen.....	1-6
	1.7.4 Safety norms and suggestions.....	1-7
1.8	Uses not foreseen.....	1-9
1.9	Guarantee.....	1-9
1.10	Assistance.....	1-9
	1.10.1 Demand for assistance interventions.....	1-9
1.11	How to use the available documentation.....	1-9
	1.11.1 Use of the handbook.....	1-9
1.12	Handbook preservation.....	1-10
1.13	Conventions.....	1-10
	1.13.1 Typographical conventions.....	1-10

Chapter 2 **D**escription 2-1

2.1	Machine description.....	2-1
	2.1.1 Machine function.....	2-1
	2.1.2 Working principle.....	2-1
	2.1.3 Structure.....	2-1
	2-2
2.2	Properties.....	2-3
	2.2.1 Noise.....	2-3

2.3	Responsibility.....	2-3
Chapter 3 Installation 3-1		
3.1	Storage.....	3-1
	3.1.1 Characteristics of the storage area.....	3-1
	3.1.2 Environmental characteristics of the storage area.....	3-2
3.2	Transport.....	3-2
	3.2.1 Transport conditions.....	3-2
	3.2.2 Transport.....	3-2
	3.2.3 Lifting.....	3-2
	3-3
	3.2.4 Preliminary operations.....	3-3
	3-4
3.3	Collocation.....	3-4
	3.3.1 Physical characteristics of collocation.....	3-4
	3-5
	3.3.2 Environmental characteristics of the collocation area.....	3-5
	3.3.3 Connections.....	3-5
	3-6
3.4	Test.....	3-7
Chapter 4 Use 4-1		
4.1	Operator's qualification.....	4-1
4.2	Danger zones.....	4-1
4.3	Drives and signals.....	4-2
	4.3.1 Drives.....	4-2
	4-3
4.4	Working.....	4-3
	4.4.1 Machine setting and ignition.....	4-3
	4.4.2 Suggestions for a good piling-up.....	4-3
	4-4
	4.4.3 Working modalities.....	4-4
4.5	Working problems.....	4-5
	4.5.1 The truck does not move.....	4-5
	4-6
Chapter 5 Maintenance 5-1		
5.1	Maintenance obligations in accordance with CE 2006/42 directive.....	5-1
5.2	Periodical maintenance checks and technical advice.....	5-2
	5-3
5.3	Danger zones.....	5-4
5.4	Routine (periodical and preventive) maintenance.....	5-4
	5.4.1 Operator's qualification.....	5-5
	5.4.2 Cleaning.....	5-5
	5.4.3 Periodical inspections.....	5-6
	5.4.4 Special maintenance.....	5-7

Chapter 6 Dismantling 6-1

6.1	Machine deactivation.....	6-1
6.2	Deactivation procedures.....	6-1
	6-2
6.3	Risks solved after the machine deactivation.....	6-3

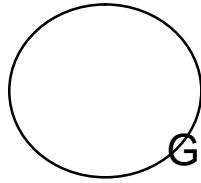

1.1 Available documentation

1.1.1 This handbook

- Handbook data.
 - Use and maintenance handbook of the DELTA CP AC-evo Lift Truck
 - Edition: 1.0
 - Version: 1.0
 - January 2013
- Consignees.
 - Carrier
 - Installer
 - User
 - Maintenance operator

1.2 Information ownership

This handbook contains confidential information. All rights are reserved.

This handbook cannot be reproduced or photocopied, partially or wholly, without the written authorisation of ARMANNI. The utilisation of this documentation is allowed only to the customer to whom the handbook has been supplied as a machine equipment, only for installation, use and maintenance of the machine handbook.

ARMANNI states that all information of this handbook is in compliance with the technical and safety specifications of the machine handbook. ARMANNI declines all responsibilities for direct or indirect damages to persons, things or domestic animals due to the use of this documentation or of the machine in conditions different from the ones suggested.

ARMANNI has the right to change or improve this handbook and ARMANNI machines without any advance notice, even the machines commercialised with the same nameplate as the one of this handbook but with a different serial number. The information of this handbook particularly refers to the machine described in 1.4 "Machine identification data".

1.3 Manufacturer's identification data

ARMANNI CARRELLI ELEVATORI s.r.l.
Via Serio 15
24021 ALBINO (BG)
Tel. +39 035 752909

1.4 Machine identification data

- Denomination: LIFT TRUCK
- Model: CP LIGHT evo 020 ASPO
- Serial number:
- Construction year:
- Possible accessories added:
- For the accessory instruction handbook see enclosures

IDENTIFICATION NAME PLATE
POSITION

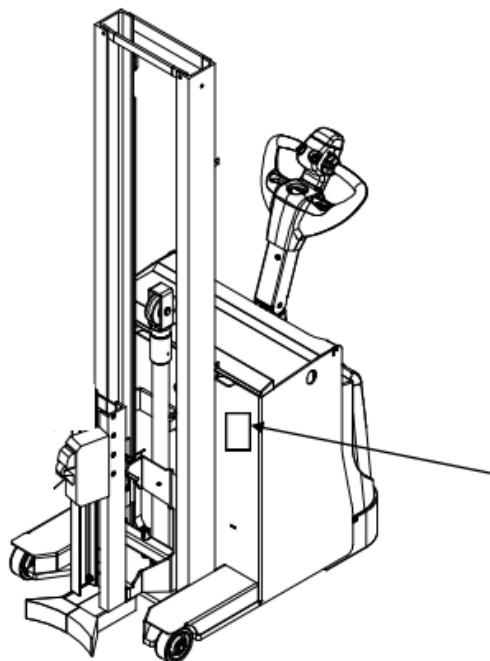

Fig. 1.1 Identification name plate position



ARMANNI CARRELLI ELEVATORI S.R.L.
 VIA SERIO N°15 - 24021 ALBINO (BG) - ITALIA
 TEL. +39 035752909 FAX +39 035754533 www.armanni.com

MOD.		
S/N		V. <input type="checkbox"/>
MASSA A VUOTO - UNLOADED WEIGHT - POIDS A VIDE - EIGEN GEWICHT - PESO SIN CARGA		
MASSA BATTERIA - BATTERY WEIGHT - POIDS BATTERIE - GEWICHT BATTERIE PESO BATTERIA		
PORTATA NOMINALE - RATED CAPACITY CAPACITÈ NOMINALE - NENNTRAGKRAFT CAPACIDAD		
ALZATA MAX - LIFTING MAX - LEVEE MAX - MAX HUBHOEHE ELEVACIÒN MAX		

Fig. 1.2 Identification name plate

1.5 CE conformity statement

See enclosure: *CE conformity statement*

1.6 General safety instructions

During the design and construction of this machine methods and precautions have been adopted in order to meet the essential safety demands in compliance with the 20069/42/CE Directive and subsequent changes and with applicable norms. In particular, during the design and construction phases precautionary measures have been adopted in order to prevent risks for the operators during installation, use, maintenance, disassemble and deactivation of the machine. The complete documentation of the safety measures is included in the technical brochure of the machine.

Thanks to the accurate examination of the risks carried out by the manufacturer most risks in relation to the expected and foreseeable conditions of the machine use have been eliminated. The possible protections to eliminate completely the fall risk of the load from the forks would seriously compromise the functionality and versatility of the machine. Consequently, the residual fall risks of the load from the forks are described in this manual.

ARMANNI recommends to read carefully the instructions, procedures and suggestions of this handbook and follow the safety norms in force and the use of the protection equipment, both those supplemented in the machine and the individual ones.



ARMANNI declines all responsibilities for possible damages to persons or things due to the non-observance of the safety norms and recommendations included in the documentation.

1.6.1 Passive safety devices

DEFINITION

Such devices are the devices or precautions that eliminate or reduce the risks for the operators without any active intervention from the operators.

Microswitch: the presence of the limit switch reduces the movable fork movement at the maximum height.

Protection grating: it prevents the operator from bringing his hands near to the moving parts during the load rise and descent.

Bumper on the forks: it prevents the load from falling down on the operator in case of oscillation.

An important passive safety device is the parachute valve situated in the connection between the hydraulic plant and the cylinder. In case of a sudden leakage or a break inside the hydraulic circuit, it locks the load movement in a very short time and avoids the abrupt descent to the ground.

Rubber foot guard: it prevents the operator's foot from going under the truck.

Safety push-button: in case of contact with the operator, it instantaneously stops the truck stroke and avoids the squashing.

When the load is lifted at a height of more than 300 mm from the ground, the truck translation speed is automatically reduced to a lower value by means of a microswitch positioned near the mast. Also this device serves as a passive safety device.

1.6.2 Active safety devices

Such devices are the devices or precautions that eliminate the risks for exposed operators or persons or that reduce the risks that can not be eliminated during the design. Such devices require active and aware interventions from the operator.

The continuous action switches and the lever for the forks lifting/lowering are active safety devices; in case of intentional release, they cause the forks movement stop.

The same counts for the onward-backward drives of the truck.

The emergency switch is an active safety device as well since it locks the whole system when operated in case of danger.

Finally, also the "safety push-button" can serve as an active safety device because it can be controlled by means of an intentional manoeuvre, too.

1.6.3 Personnel qualification

The machine working is safe when used by qualified personnel in accordance with the recommendations and instructions of this handbook. All installation, use and maintenance operations of the machine shall be carried out only by authorised and qualified personnel after having acquired the instructions supplied by this handbook.



ARMANNI declines all responsibilities for possible damages to persons, things or domestic animals due to the use of the machine from unqualified operators.

1.6.4 Danger zones

DEFINITION

A danger zone is any zone inside or near the machine in which the presence of an exposed person represents a risk for the health and safety for that person.

1.6.5 Danger zones of the machine during use and maintenance

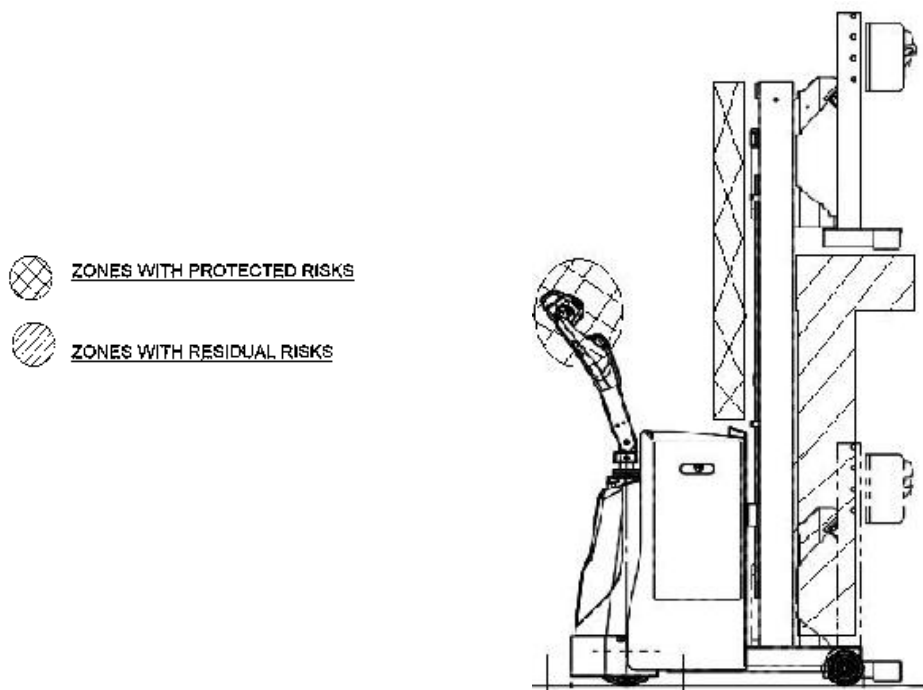

Fig. 1.3 Danger zones of the machine during use and maintenance

**DANGER**

Each operator shall carry out the operations for which he has been appropriately instructed.

- During installation, use and maintenance operations use appropriate means of personal protection.

The non-utilisation of adequate protection means may be a danger for the operator.

**NOTE**

ARMANNI declines all responsibilities for possible damages to persons or things due to the non-observance of the safety norms and recommendations included in the documentation supplied.

1.6.6 Personal protections

The utilisation of protective gloves and safety steel-toed shoes is foreseen for the machine use

1.7 Uses foreseen

1.7.1 Operations foreseen

- Drum positioning
- Drum lifting
- Drum movements

1.7.2 Installation modalities foreseen

The following conditions are necessary for the machine installation:

- An environment with sufficient lighting
- Flat surfaces without holes

1.7.3 Operation modalities foreseen

- The machine is fed by internal electric energy, which is converted into mechanical, hydraulic and movement energy for the uses foreseen.
- One single operator is foreseen for the safe use of the machine.

1.7.4 Safety norms and driving suggestions

In order to use the lift truck safely it is necessary to follow some precautionary norms:

- Only the authorised personnel is allowed to use the truck
- In the work area of the truck there shall be nobody for 8 m. at least, so as to avoid accidents due to the accidental fall of the load.
- While using it, always keep a correct manoeuvre position.

The load shall have the following dimensions in order to work safely: (See Fig. 1.4):

- As for width, its dimensions shall not project from the load holder grating and have the barycenter (G) on the longitudinal axis.
- As for length, it shall not exceed a length of 1200 mm and have the barycenter (G) positioned at a distance lower or equal to the C distance (reported in the technical specifications) from the load holder grating.

As for height two cases may occur:

- 1- If the load is not packed, it shall not absolutely project from the load holder grating
- 2- If the load should project from the load holder grating, the load transport can be carried out only when it is appropriately packed as one single body with all its parts (for example, a pallet consisting of a lot of boxes firmly piled up and cellophaned); In order to reduce the fall risk it will be necessary to keep the load barycenter lower than the load holder grating.

If you follow these regulations, you will obtain a correct load positioning and a weight equally distributed on the forks surface, consequently the load balance will be very stable, thus reducing to a minimum the accident risk due to the accidental fall of the load.

- All movements inside the firm shall be carried out only along the yellow stripes on the floor.
- During the movements from one area to the other always keep the forks at a maximum height of 20 cm from the ground.
- Never overload the truck.
- Center the load on the two forks, so that its barycenter falls on the longitudinal axis of the truck and the weight is equally distributed on the forks (always refer to the diagrams of the technical specifications and the label on the mast).
- If the load should hinder the visibility during the movements, carry out a reverse and go on by keeping the truck behind you.
- Be careful with the piling-up of the material; when starting, avoid abrupt manoeuvres, stops and steering; Carry out the loading, unloading and movement operations by keeping the truck motion as straightaway as possible.
- Moderate the speed in the dangerous zones or near obstacles.
- Be careful with slopes, in particular never pass through slopes superior to 5%. Never pass transversally through slopes. Keep rigorously the forks at a maximum height of 20 cm from the ground.
- Use the audible alarms if necessary.
- In case of any danger, turn immediately the emergency key anticlockwise.
- Never get near the battery during the recharge with free flames. Read carefully the use and maintenance handbook of the battery in order to obtain a perfect efficiency.
- Be careful with fires and explosions, especially in environments where gas fumes or fuels are present. The truck is not explosion-proof.
- Never leave the truck with hanging loads or with the forks lifted.
If it is unattended, take the key out of the control panel. Park the truck only in appropriate areas or far from other work areas or working machines (minimum distance: 5m.).

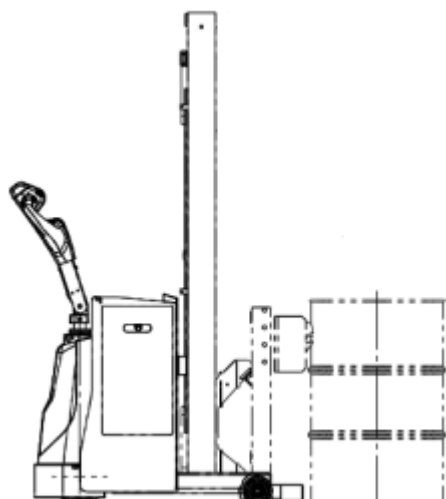
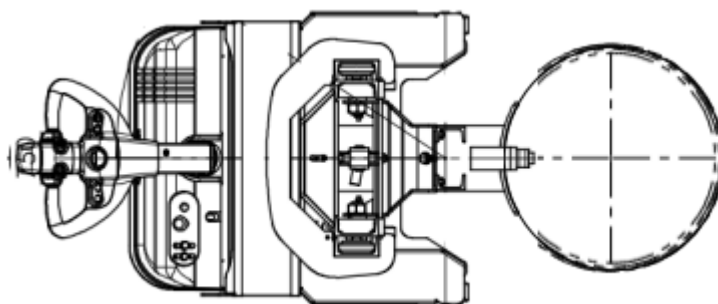

Fig. 1.4 Load position



Fig. 1.5 Correct attachment



DANGER

The non-observance of the regulations for the load positioning previously mentioned can seriously increase the fall risk of the load with consequent physical damages to the operator.

1.8 Uses not foreseen

The uses not foreseen are the uses that are not expressly specified in 1.7 *Uses foreseen*, and in particular:

- The use of the lift truck as an elevator for the rise or descent of persons or for the transport of persons besides the operator (see version with footboard for operator's transport).

1.9 Guarantee

For the general conditions of guarantee refer to *Certification of guarantee*, in the 3 *Enclosure*.

1.10 Assistance

The supplier places at his own clients' disposal an Assistance Service

1.10.1 Demand for assistance interventions

In case of problems during the machine use, it is advisable to read this handbook. Contact the Assistance Service to solve the problems not mentioned in the handbook or if the problem persists even after your intervention.

Assistance Service

In case of necessary interventions:

During the guarantee period please contact:

ARMANNI manufacturer

Once the guarantee period is expired, address to:

ARMANNI if the jobber or the assistance centre is unknown.

For spare parts address to:

ARMANNI if the jobber or the assistance centre is unknown.

1.11 How to use the available documentation

1.11.1 Use of the handbook

Before using the machine and carrying out any maintenance operation, read carefully the conditions given by this handbook.

Table 1.1 How to use the documentation

If you want to:	Read
Transport, move, load, unload and operate the machine	Chapter 3 Installation
Set and equip the machine	Chapter 4 Use
Use the machine already installed and set	Chapter 4 Use
Carry out regulations during the use	Chapter 4 Use
Solve the use problems	Chapter 4 Use
Estimate and carry out maintenance	Chapter 5 Maintenance
Deactivate or dismantle completely the machine	Chapter 6 Dismantling

1.12 Handbook preservation

This handbook and the whole documentation shall be preserved for all the technical duration of the machine. In case of sale of the machine used, the machine shall be sold along with the documentation supplied.

1.13 Conventions

1.13.1 Typographical conventions

- **Italics text:** it refers to the title of a chapter, a section, a sub-section, a paragraph, a table or a figure of this handbook or another reference publication.



NOTE

The notes contain important information, highlighted outside the text they refer to.



ATTENTION

The attention references indicate those procedures whose non or partial observance can cause damages to the machine or its equipment.



DANGER

The danger references indicate those procedures whose non or partial observance can cause physical damages to the operator.

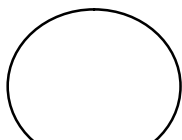

2.1 Machine description

2.1.1 MACHINE FUNCTION

The lift truck is used for lifting and lowering loads and positioning them as desired; or, once they are lifted from the ground, it is useful for their transport, for short distances (inside a workshop, warehouse, truck loading/unloading, storage on stands etc.).

2.1.2 WORKING PRINCIPLE

The lift truck moves objects vertically with onward-backward movements or towards a direction desired by the operator, since he can change both direction and the running direction by means of the steering wheel.

- * Rise
 - The high oleodynamic pressure due to a pump connected in series with an electromotor moves the stem of an hydraulic cylinder, which, fastened to the basement and pivoted on a support welded to the internal mast, moves it vertically. Inside the two mast guides, by means of a pulley and chain system, the movement is transmitted to the forks, in the same translation direction as the stem.
- * Descent
 - The force of gravity operates on the forks which drag downward the whole system moved during the rise. The descent speed is kept constant by the action of a balancing valve in the gear-case that checks the oil flow from the cylinder to the tank.
- * Movement
 - The electromotive force supplied by the motor-wheel gives a motion to the truck; this motion will be appropriately proportioned and controlled by means of the drives positioned on the steering wheel. The speed is changed by means of a potentiometer in the steering wheel, while the movement stop is controlled by an electromagnetic brake positioned on the same wheel.
- * Steering.
 - The directional control of the truck is obtained by means of electromechanical power steering; by rotating the steering arm around its vertical axis, the operator will control the rotation of the driving wheel around the relevant steering axis

2.1.3 Structure

The main structural elements of the machine are the following:
Mechanical electro-welded steel structure.

- Basement for driving wheel consisting of a closed basement welded .
- External mast, pivoted onto the base by means of specific supports .

- Internal mast or headframe sliding inside the external mast.
- The cylinder-stem group
- Traverse cylinder assembly
- The steering wheel group that serves as a steering and manoeuvre point of the truck.
- The motorwheel.
- The forks group that is integral to the headframe by means of a pulley-chain connection.
- The sump group.

Electric installation:

- Gearcase of electric installation control including an electronic card protected by a plastic sump.
 - Two fuses
 - LED ignition
 - hour counter
 - LED series which indicate the battery charge condition
 - Emergency button to deactivate the electric installation
 - 24 V battery
- Motorwheel including:
 - Electromotor
 - Electrobrake
 - Geared motor.
 - Steering motor.
- Switches
 - A limit switch for the rise
 - Switch for the automatic speed reduction
 - Key switch for starting
 - Emergency button switch

Hydraulic system

- Hydraulic pump
- Tank built-in in the pump
- Hydraulic gearcase:
 - 24 V electromotor
 - Gearcase lock
 - Solenoid valve
 - Maximum pressure valve
 - Nonreturn valve
- Filter
- Flow adjustment valve to check the oil downflow from the cylinder
- Parachute-type valve to stop the oil flow and the load descent in case of break of the hydraulic system
- Connectors
- Plastic pipelines

Drive device:

- Rise-descent lever
- Tilting lever
- Electric horn
- Key switch
- Drive devices of onward-backward truck movement
- Emergency switch
- Safety stop cap

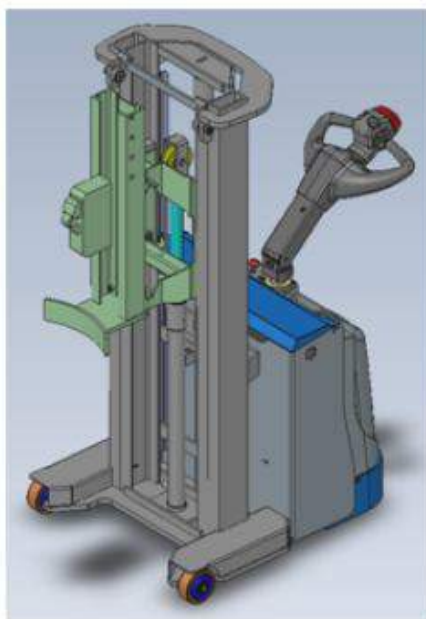

Fig. 2.1 Photograph of the machine

2.2 Properties

2.2.1 Noise

The parameter values of the aerial noise caused by the machine are within the limits in accordance with the 2006/42/CE European Directive.

- The weighted continuous equivalent level A of the acoustic pressure is under 70 dB (A)
- The maximum value of the weighted instantaneous acoustic pressure C is under 63 Pa

2.3 Responsibilities



ARMANNI declines all responsibilities for possible inconvenience, failures or malfunctioning due to the non-observance of the feed values supplied.

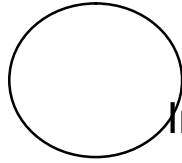

The instructions of this section shall be followed during the periods of temporary storage of the machine that can occur in the following situations:

- Machine installation not immediately after its supply
- Machine disassemble and storage awaiting its re-collocation

In case of non-observance of these instructions, ARMANNI declines all responsibilities for possible damages to the machine or subsequent performance not in compliance with the technical specifications supplied.

3.1 Storage

3.1.1 Characteristics of the storage area

The machine shall be collocated in a space having the following characteristics:

Dimensions

Besides the overall dimensions of the machine, it is necessary to provide for the appropriate circulation and manoeuvre spaces so as to allow the personnel to carry out safely and comfortably the machine sling and lifting.

Protection from environmental and external agents

The storage area shall be covered and protected by the action of the atmospheric precipitations and is accessible to authorised personnel only.

Supporting plane capacity

The floor shall assure a whole capacity (G) equal to:

$$G = \frac{P.K \cdot 9,81}{1000} = \frac{Kg \cdot 1,1 \cdot 9,81 \text{ m/S}^2}{1000} = \dots\dots\dots\text{KN}$$

Where: G = whole capacity referred to the whole storage area, expressed in (KN)
 P = machine weight, expressed in (kg)
 K = fixed increased coefficient, in order to include the packaging weight in the calculation
 9,81 = gravity acceleration expressed in (m/S²)
 And consequently a unit load (C) equal to:

$$C = \frac{G \cdot 1000}{S} = \frac{KN \cdot 1000}{m^2} = \dots\dots\dots N/m^2$$

Where: C = minimum unit load, expressed in (N/m²)
 S = support surface, expressed in (m²)

3.1.2 Environmental characteristics of the storage area

- Temperature admitted: from 0° C to 40° C +/-5° C.
- Relative humidity admitted: from 30% to 90% +/-5%

3.2 Transport

3.2.1 Transport conditions

The machine shall be transported in the following conditions:
 Position the truck with the forks lowered

- Cover completely the truck with a plastic covering to protect the machine from atmospheric agents.

The machine is normally delivered wrapped in a cellophane cloth.

ATTENTION

If there should be particular height problems in the vertical positioning, the truck can be positioned horizontally on one side (left or right, indifferently) removing the battery and putting a cap to the oil tank before carrying out the operation.

- The bolts and any other material supplied with the machine shall be put into plastic bags.

Total weight

See technical specifications

3.2.2 Transport

During the transport, the machine shall be correctly covered with cellophane and fastened to the means of transport so as to avoid movements or turnovers. During transport operations avoid impacts or turnovers.

3.2.3 Lifting Lifting equipment

For the lifting of the machine components use:

- Cranes or lift trucks with minimum flow rate for the weight of the truck
- Four terminal sling accessories

Procedures

Sling the machine in the appropriate slots provided in the lower part of the base as in Fig.3.1 lifting points of the machine.

- The machine is ready for the lifting

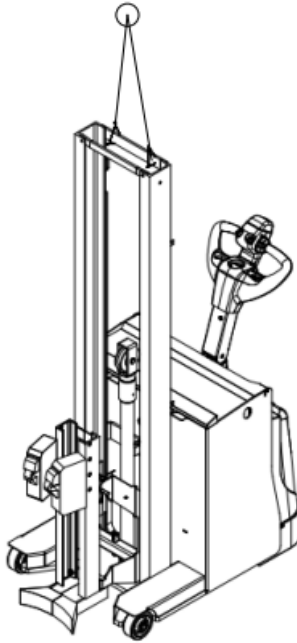

Fig. 3.1 Machine lifting points

3.2.4 Preliminary operations

Unpacking

- Remove the plastic wrapping covering the machine.

Preservation of the transport accessories

When the lift truck is transported horizontally, the drilled gearcase plug is normally replaced with a closed plug; keep the closed plug for the next machine transports.

Verification of the damages occurred during transport

Before installing the machine check the presence of possible damages occurred to the machine components during transport.

Check in particular the condition of the following components:

- Lifting stem and cylinder of the lift truck
- Chain and chain pivots
- Limit switches
- Emergency switches
- Motor feed cables
- Hydraulic pump
- Control panel

Machine cleaning

Remove the machine dust and dirt due to the transport. Use a rag or compressed air.

In case of damages

Before using the machine, it is necessary to check its conditions. The damages due to transport are attributed to the carrier and immediately communicated to the supplier.

3.3 Collocation

The physical characteristics and pre-arrangement procedures of the collocation areas of the truck are described as follows:

3.3.1 Physical characteristics of the collocation area

Space requirements

The machine simply needs a work area suitable for its dimensions supplied in the *Technical specifications* in order to obtain a good manoeuvrability; the work surface shall be flat and smooth.

Flooring

The floor shall have a slope not over 1% and be without holes. Furthermore, the floor shall assure a whole work capacity (GL) equal to:

$$GL = \frac{(P + Q) \cdot 9,81}{1000} = \frac{(Kg + Kg) \cdot 9,81 \text{ m/S}^2}{1000} = \dots\dots\dots\text{KN}$$

Where: GL = whole work capacity expressed in (KN)
 P = machine weight expressed in (Kg)
 Q = machine capacity expressed in (kg)
 9,81 = gravity acceleration expressed in (m/S²)

Consequently, a work unit load (CL) equal to:

$$CL = \frac{GL \cdot 1000}{S} = \frac{KN \cdot 1000}{m^2} = \dots\dots\dots N/m^2$$

Where: CL = minimum work unit load, expressed in (N/m²)
S = machine support surface, expressed in (m²)

In addition, the floor shall assure a whole capacity of 20 KN/m² referred to the whole storage surface and a minimum unit load of 20 KN/m².

Lighting

In order to carry out safely and correctly the working and maintenance operations of the machine a good lighting is necessary. The machine is not equipped with a built-in lighting system.

A room lighting having a normal value allows any operation without any risks due to shadow areas.



DANGER

The use of the machine is authorised to one single operator. It is advisable not to park the machine near a work area or a passage area of other persons. Refer to 1.6.4 *Danger zones*. Never leave hanging loads.

Protection from atmospheric agents

The machine shall be collocated in a covered place protected from the direct contact with atmospheric agents.

3.3.2 Environmental characteristics of the collocation area

- Temperature admitted: from 5° C to 40° C +/- 5° C
- Relative humidity admitted: from 30% to 90% +/- 5%

3.3.3 Electrical connections

The machine is provided with a cable in order to connect the battery charger to the electrical net.

The battery and the battery charger are usually supplied along with the machine, but they cannot be supplied on request (in this case it will be supplied a cable with two connectors in order to connect the battery to the battery charger).

The battery shall have the following requirements:

Voltage: 24V; maximum amperage: 288Ah

The battery charger shall have the following requirements:

Battery recharge capacity: 24 V

The battery-battery charger connection, with the battery charger broken up, is carried out as described in Fig. 3.1:

Use instructions of the battery charger

1. **Connection to the supply mains 220V 50Hz**

Before connecting the rectifier to the supply mains make yourself sure that the voltage corresponds to the data reported on the nameplate of the battery charger, that is 220V.
It is advisable to use a 15Ah plug with earthing.
2. **Connection to the battery**

Lift up the battery room cover and check that the battery has already been introduced in the transpallet. Disconnect the battery plug from the electric circuit of the transpallet and connect it to that of the battery charger. During the connection (battery-battery charger), on the front panel of the battery charger the led checking the connection between battery and battery charger lights up. Open all caps of the elements and check the liquid level.
3. **Charge start**

Press the ON push-button, the rectifier starts the charge cycle signaled by the LED placed on the control panel and by the amperometer signaling the charge condition of the battery. In case of emergency press the OFF push-button to interrupt the cycle and disconnect the battery charger from the supply mains 220V.
4. **Charge end**

The end of the charge operation is signaled by one more LED placed on the battery charger and by the amperometer zeroing. Disconnect the battery from the battery charger only when the battery charger is off. Re-connect the battery plug to the transpallet circuit plug and close the battery room cover.
5. **Working lack**

The working lack of the battery charger may be due to:

 - Voltage lack in the supply mains
 - Protection fuse intervention of the battery charger; switch off the battery charger and disconnect the pin from the line plug, open the battery charger, remove the protection sump and replace the fuse with one of the same kind.

indicates anomaly, it starts when the charge is over 13 hours. See fig. 3.2

**ATTENTION**

The battery charger shall not be absolutely washed with bolts of water or steam cleaning machines. This operation may seriously compromise the functionality and safety of the device.

Electronic control

The lift truck is provided with a MOSFET electronic control that adjusts the current pulses, according to the necessities.

Thus, it is possible to avoid abrupt accelerations in the running direction unlike the lift trucks controlled by means of electric circuits (current metering by means of electric resistance that incandescents).

In addition, you have an energy saving with a consequent increase of the work autonomy in about 35%.

The electronic control is provided with safety circuits (see CEE norms - fuses) that are appropriately calibrated and protect the lift truck working, if serious conditions compromising the elements integrity should occur.

With the electronic control, the wrong manoeuvres from the operator do not really occur. In fact, for example, even during an abrupt acceleration, the speed change occurs gradually and according to a ramp pre-arranged. If the running direction is abruptly reversed, an automatic and controlled speed decrease is obtained till the stop and is followed by a starting in the opposite direction.

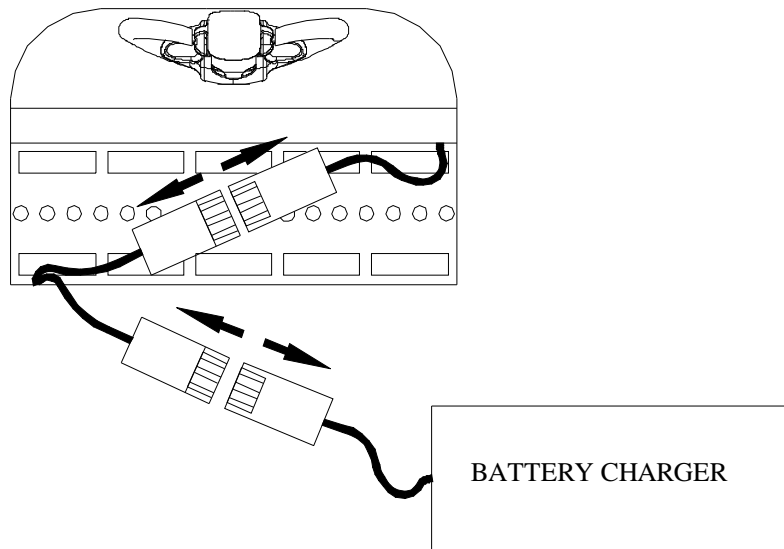

Fig. 3.2 Connection battery-charger in the case the charger battery is not provided with the machine (For use see the instruction book of the charger).

3.4 Test

The machine is tested by the constructor before going out of the factory. The test includes the static and dynamic tests to guarantee that the machines have been produced and assembled correctly.

The tests carried out are:

- General inspection of the lift truck in order to find possible assemble errors.
- Test without load so as to check the correct working of the hydraulic and mechanical systems and control devices.
- Fully laden static test for different heights
- Fully laden dynamic test in rise and descent
- Check test of the safety device efficiency
- Loadless translation test and with maximum load
- Loadless brake test and with maximum load.

This chapter describes the use functions and modalities of the machines.

4.1 Operator's qualification

The machine can be used by one single operator in order to eliminate the risks due to movements and the truck movement along with the load. For the lift truck use, no specialised qualification is required, but it is advisable to use it carefully so as to avoid damages to things or persons.

4.2 Danger zones

Definition

The danger zones are the zones inside and near the machine in which the presence of an exposed person represents a risk for the health and safety of that person.

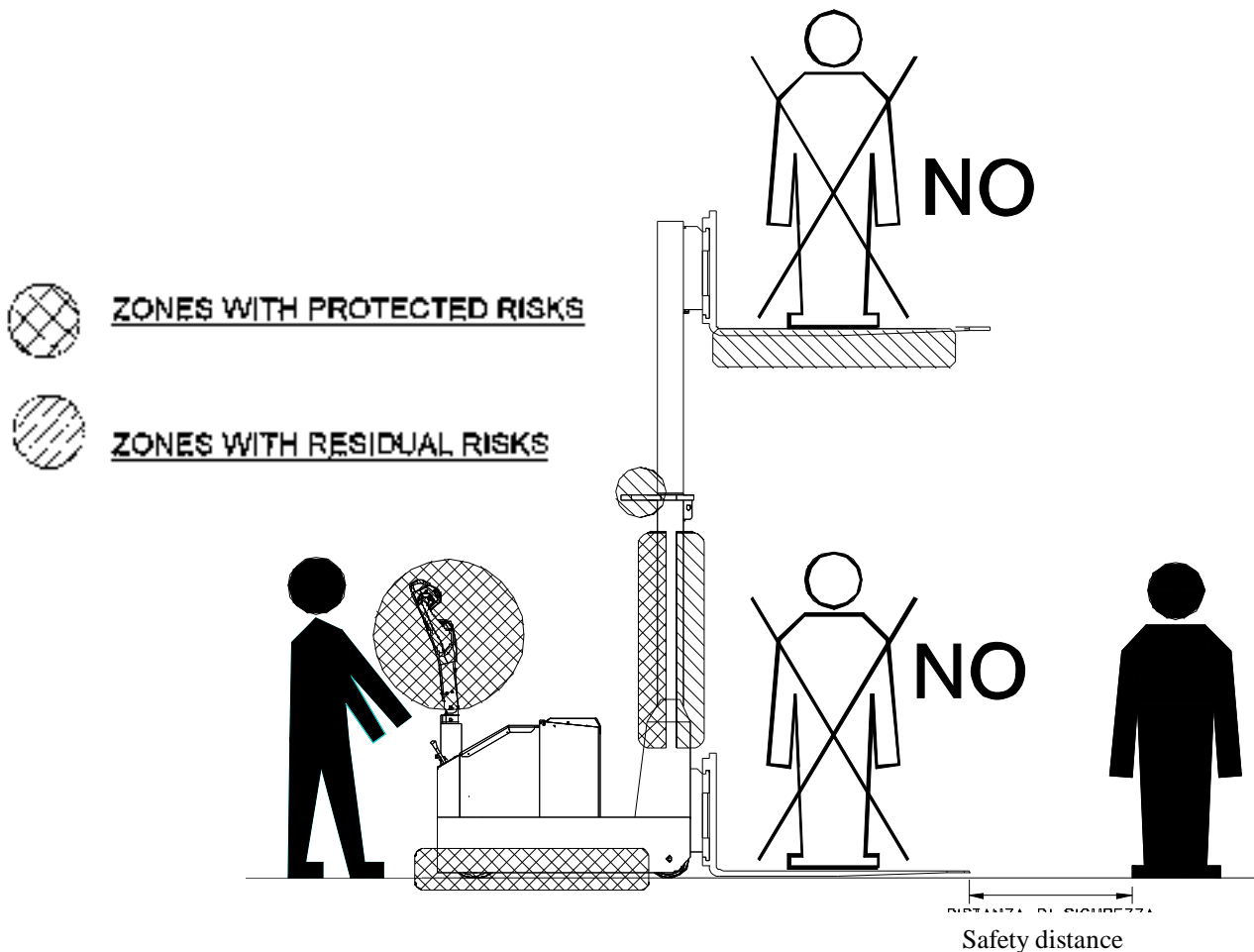

Fig. 4.1 Operator's position and danger zones of the machine during its use.

4.3 Drives and signals

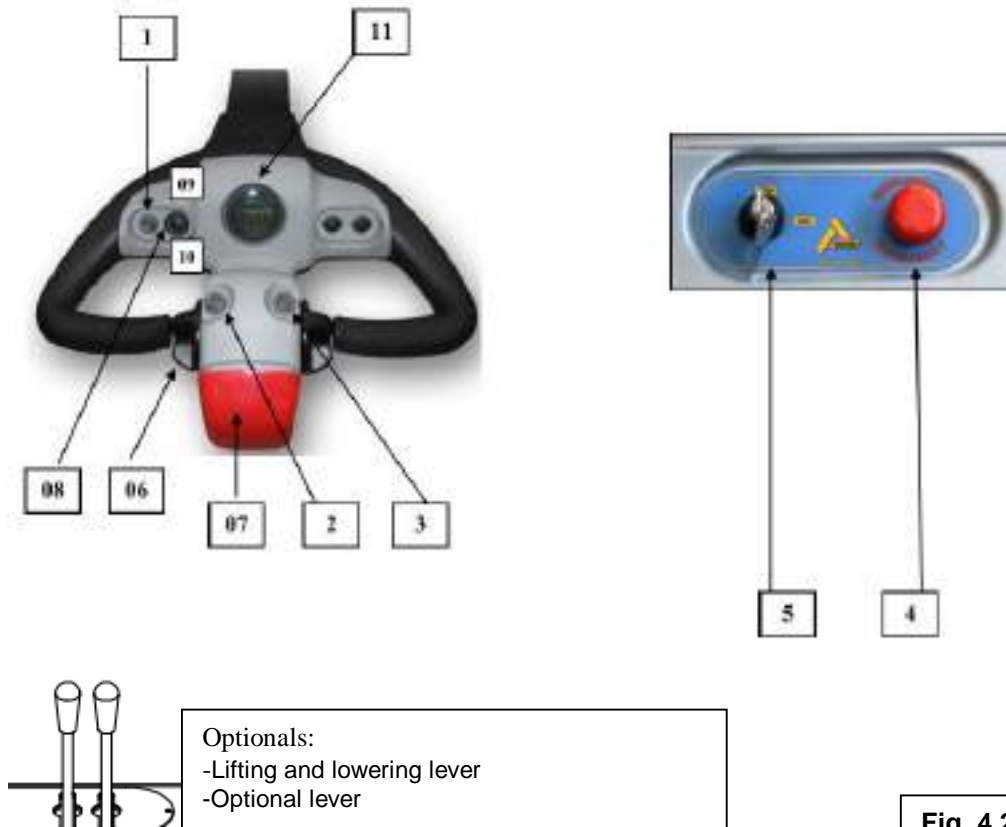

Fig. 4.2 Panel control

4.3.1 Drives

The drives for the truck working are both on the driving steering wheel and on the instrument board, as you see in Fig. 4.2

Their functions are described as follows in position order:

- 01:** Audible signal push-button: by pressing it, it closes a circuit that gives voltage to an electric horn that produces the sound; by releasing it, the sound is interrupted and returns to the initial position.
- 02/03:** Lifting and lowering push buttons; pull for lift or lower the forks;
- 04:** Emergency button. The button is provided with a mechanical locking system that, after being activated, will retain the red mushroom-head button in the stop position (pressed button position). If you press the button downwards, the current will be interrupted for the entire system.
NOTE: For the normal operation of the truck, the emergency button must be in the released position; to release the button, pull the red mushroom-head activation button upwards.
- 05:** Key switch: it is the machine ignition switch; it is activated by introducing the key and carrying out a slight rotation clockwise, at the same time the 05 pilot light will light up.
- 06:** Butterfly control device: this device controls the onward-backward running of the truck; the devices are two, one for each handgrip (right and left) and work at the same time (when one rotates, automatically the other one rotates as well, since they are connected by a spindle). It works as follows:
 - By gripping the knob, rotating onwards the butterfly device with the thumb and operating on the tongues it is possible to obtain an accelerated movement onwards of the truck; by releasing the thumb from the tongues, the truck returns to the initial position with a constant deceleration. When the deceleration is over, the stop force of the electrobrake damps the inertial force acquired by the truck weight and stops it.

- By gripping the knob, rotating backwards the same device with the thumb on the appropriate tongues it is possible to obtain an accelerated movement backwards of the truck; by releasing the thumb from the tongues, what has been previously mentioned occurs.
- 07:** Safety stop cap: it is a spring cap, under which a release switch is positioned and disconnects and connects the circuit whenever it is pressed and released.
- 10:** Safety stop cap: it is a spring cap, under which a release switch is positioned and disconnects and connects the circuit whenever it is pressed and released.
- 08:** Speed selector :
 - Position 09 – Lower speed
 - Position 10 – Normal speed
- 11:** Indicator for the charging conditions of the battery. If you turn the key to the "ON" position, the indicator will perform a short test. After that, the charging condition will keep displayed. It is a percentage value scale included between 0 and 100. It is advisable to recharge the battery before the second-last notch turns OFF. In addition, the display will show the total hours of truck operation.
The aforesaid display includes a red LED that shows possible operation irregularities of the truck (alarm). When the truck is in alarm condition, it will not operate. If the LED blinks, you must turn the machine OFF and ON; if the alarm condition persists, you must call the customer assistance service.

4.4 Working

4.4.1 Machine setting and ignition

The lift truck is equipped with all protections in accordance with the safety norms in order to obtain a correct machine working and the operator's safety. It is advisable to follow strictly the use norms reported as follows:

- Remove the protection sump of the battery compartment and check that the battery is in the truck.
- Check that the emergency switch is in the insertion position.
- Insert the ignition key in the switch with the lock positioned on the instrument board and rotate it clockwise from the OFF position to the ON position.
- Check the ignition of the LED on the drive.
- For the forks lifting and lowering pull the relative lever .
- For the movement, rotate the butterfly switch (see Fig. 4.2, 09 particular) as described in the previous chapter *4.3.1 Drives*.

4.4.2 Suggestions for a good piling-up

- Slowly get near to the pallet to be lifted, with the forks on the ground.
- Introduce the forks into the appropriate spaces on the pallet
- Once sure that the truck position is correct in comparison with the forks, lift the load slowly as far as the forks are at a maximum height of 20 cm from the ground.
- Get near to the place where the load must be positioned keeping a safety distance of about 50 cm with the forks.
- Gradually lift the load up to a height superior to the piling-up plane in about 8 cm.
- Gradually get near at moderate speed, avoiding abrupt starts, steering and stops that may cause the load fall.
- Once the correct position is reached, stop the truck, lower the forks slowly as far as the pallet reaches the pile.
- Once the pallet has been lain down, slightly lower the forks as far as they are free of any load; the lower part of the forks must not touch the pile.
- Slowly go back and with the forks go out of the pile or shelving area. Once the forks are far from this area at least 1/2 meter lower them to the ground and carry out the following operation.

In order to remove a piled-up pallet it is necessary to do what follows:

- Get near to the piling-up place with the forks lowered
- Stop the forks at least at 50 cm from the pile or stand

-
- Lift the forks up to the desired height of the pallet in a position that allows the forking without touching the pallet or the pile.
 - Get near slowly and fork the pallet without causing accidental impacts with the forks.
 - Once the forks position is correct, lift the pallet slowly up to a height of 10 cm from the supporting plane.
 - Go back with the pallet and go out of the pile or stand area in about 50 cm.
 - Lower the forks slowly with the load up to a fork height of 20 cm from the ground
 - Move the load to the position desired.

Never overload the truck in order not to compromise the stability and the good working. As for the maximum admitted capacity always refer to the diagrams reported in the technical specifications and on the nameplate applied on the mast. Make yourself sure that nobody is under or above the load during the rise or descent operations.

4.4.3 Working modalities

For the use modalities see *4.3 Drives and signals*, for information and technical data refer to *Technical specifications*.

Overload working

In order to avoid overloads, the maximum pressure valve is calibrated for a pressure value a bit higher than the maximum allowed load. In case of overload the lift truck will behave as follows:

Rise

- At the beginning of the load lifting, the pressure in the oleodynamic circuit will exceed the maximum value admitted. The maximum pressure valve will drain oil into the tank and the forks will be standstill. The load is not moved.

Descent

- If there should be a too heavy load on the forks already lifted, the flow adjusting valve will keep constant the descent speed of the forks themselves. The load is moved.



DANGER

It is advisable not to exceed the load limits foreseen for the machine so as to avoid machine stresses that could seriously compromise the technical life and safety of the user.

Emergency stop

In case of danger operate on the emergency devices as mentioned in the Chapter *4.3 Drives and signals*.

Restarting after emergency stop

Reset the machine by zeroing the emergency devices and go on with the operations interrupted by means of the drives.

4.5 Working problems

4.5.1 The truck does not move

A table concerning the main possible failures that may occur while using the lift truck is reported as follows along with the possible solutions of the problems.
Remember that any repair of the truck shall be carried out by qualified and competent technical personnel. If no qualified personnel should be available for these operations, please contact the technical assistance.

First-intervention handbook of failure search	
PROBLEM	CAUSE/SOLUTION
When the key is turned to (ON), the truck does not work and the dashboard is OFF	<ul style="list-style-type: none"> - Check that the battery is live. - Check that the battery is connected with the cables of the bipolar connector and the polarity is correct. - Check that the bipolar connector between the battery and the power system is correctly connected. - Check that the emergency stop button has not been activated (red mushroom-head button in high position). - Check that all cables are connected and that the fuses are not blown.
When the starting key is turned to (ON), the dashboard switches ON, but the truck does not move.	<ul style="list-style-type: none"> - Check that the steering arm is not in an extreme position (completely lifted or lowered); a safety micro-switch is installed, which prevents the operation of the truck when the steering arm is not kept in an intermediate position. - Check the traverse motor. - Call the technical assistance service.
When the starting key is turned to (ON), the dashboard switches ON, but the lifting device does not work.	<ul style="list-style-type: none"> - Check that the maximum lifting limit-stop micro-switch has not kept pressed or is not damaged. - Check if the lifting-lowering buttons are faulty. - Check that all cables are connected. - Check the motor of the hydraulic control unit. - If necessary, replace the simple relay that is installed in the motor of the hydraulic control unit. - Call the technical assistance service.
When you turn the steering arm, the driving wheel does not turn around the steering axis (when moving, the truck does not steer).	<ul style="list-style-type: none"> - Check the steering motor. - Check the potentiometer of the driving wheel. - Check the potentiometer of the steering arm. - Check that all cables are connected. - Call the technical assistance service.
The pallet truck moves slowly.	<ul style="list-style-type: none"> - Check if the slow motion mode (turtle function) was selected. - Use a tester to check that the voltage reaches the electric brake. - Check that the electric brake operates correctly. - Check that all cables are connected. - Call the technical assistance service
The truck does not keep still after stopping.	<ul style="list-style-type: none"> - Check the wearing condition of the lining that is installed inside the electric brake. - Call the technical assistance service.
The truck suddenly starts without performing the electronic adjustment.	<ul style="list-style-type: none"> - By using a tester, check that the cables that start from the drive steering arm are not interrupted. - Check the cables that are connected with the electronic panel. - Check the electronic board by calling the technical assistance service.
When the forks are lifted more than 50 cm, the truck has no traverse force.	<ul style="list-style-type: none"> - Adjust the electronic board by calling the technical assistance service.
The forks go down by themselves	<ul style="list-style-type: none"> - Load the forks with weight and press the push-buttons and the rise descent lever many times - Clean the seal valve on the lifting gearcase - Contact the Technical Assistance
The forks go down by strokes	<ul style="list-style-type: none"> - Check the correct forks adjustment - check the descent adjusting valve on the lifting gearcase (placed on the level of the oil pipe connection), if necessary replace it - Contact the Technical Assistance
The forks do not lower.	<p>Check the adjustment of the forks (see point 5.2).</p> <ul style="list-style-type: none"> - Check that the oil filter of the solenoid valve that is installed in the control unit is not clogged. - Check that the electrical pulse reaches the solenoid valve.
The forks lower by themselves.	<ul style="list-style-type: none"> - Load a weight in the forks and activate the lifting-lowering lever various times. - Clean the retaining valve that is installed in the lifting control unit. - Call the technical assistance service.
The forks lower by fits and starts.	<ul style="list-style-type: none"> - Check that the forks were regulated in a correct way. - Check the lowering adjustment valve that is installed in the lifting control unit (installed next to the connection of the oil pipe). If it causes problems, replace it. - Call the technical assistance service.
The faulty truck blocks the way.	<ul style="list-style-type: none"> - Do not drag or push the truck to prevent damaging the driving wheel (the parking brake will automatically activate); on the contrary, use suitable lifting means to move the truck to an area where it does not cause hold-ups.

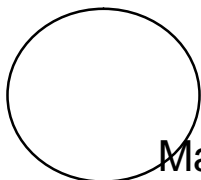

5.1 Maintenance obligations in accordance with CE 2006/42 directive

The lift truck maintenance is very important since it is aimed at preserving the operating and safety characteristics defined by the constructor in the design.

Consequently, the routine maintenance and above all the repairs shall be carried out by specialised technical personnel authorised by the constructor by using original spare parts.

The frequency of maintenance is defined by the manufacturer (see Table 5.1, section 5.4.3).

Check what follows:

1. Frame
2. Forks
3. Chains and relative pivots, tie rods, chain fastening block
4. Masts
5. Wheels
6. General screw and bolt tightening
7. Pipelines
8. Hydraulic valves
9. Brakes
10. Safety protections
11. Identification nameplates of trucks (capacity and lifting graphics), drives and equipment.

5.2 Periodical maintenance checks and technical advice

Hydraulic system

Check the seal of all pipes, pipe fittings, gaskets and oleodynamic cylinder.
Check the oil level, with the forks completely lifted, by unscrewing and removing the cap on the gearcase tank; with the help of a scaled rod check that the oil level is at about 3 cm from the bottom. If the oil level should not reach this value, carry out an oil topping up with LI 32 oil to obtain the optimum value.

Chain, nut and screw tightening check

Check all truck screws and nuts and particularly wheels, traction motor and lifting group. Check and adjust the lifting chain, pivots and chain fastening tie rods (check that the hole of the chain fastening pivot has no backlash, otherwise replace the chain fastening block by contacting the Technical Assistance). Replace periodically chain, pulley, pivots and tie rod.

Forks adjustment

In case of lateral backlash of the forks operate on the four nylon sliding blocks inside the mast (See Fig. 5.1) by means of a ch 5 setscrew wrench on the dowel inside the bush supporting them; rotate clockwise to reduce the backlash and anticlockwise to increase it. Always distribute equally the adjustment on all four sliding blocks. If the forks are inclined downwards or onwards operate on the two eccentric pivots placed on the level of the upper nylon sliding blocks; rotate the pivots one symmetrical to the other in comparison with the machine middle axis in order to avoid to lift only one of the two forks. NB - The keys for this adjustment can be supplied by ARMANNI.

Greasing

Grease the battery terminals with vaseline grease.
Grease the masts
Grease the chain and relative pulley

Electric parts

Check the insulation of the electric installation
Check the battery and the terminal oxidation (water level)
Check the tightening of the power cables in the anchor points
Check the wear of the lifting motor brushes; if necessary, replace them.

Battery maintenance

In order to obtain the best performance and a good duration of the battery, it is advisable to follow some maintenance norms:

The electrolyte level must always cover the plates, consequently it is necessary to add periodically distilled water after the charging.

Do not drop water into the battery box.

Keep dry the caps of the elements and the box.

Do not grease the connections, but only the side plugs with pure vaseline.

Do not clean the caps of the elements with any kind of diluent, but with a rag soaked in water.

For further information about the battery, read the use and maintenance handbook of the battery.

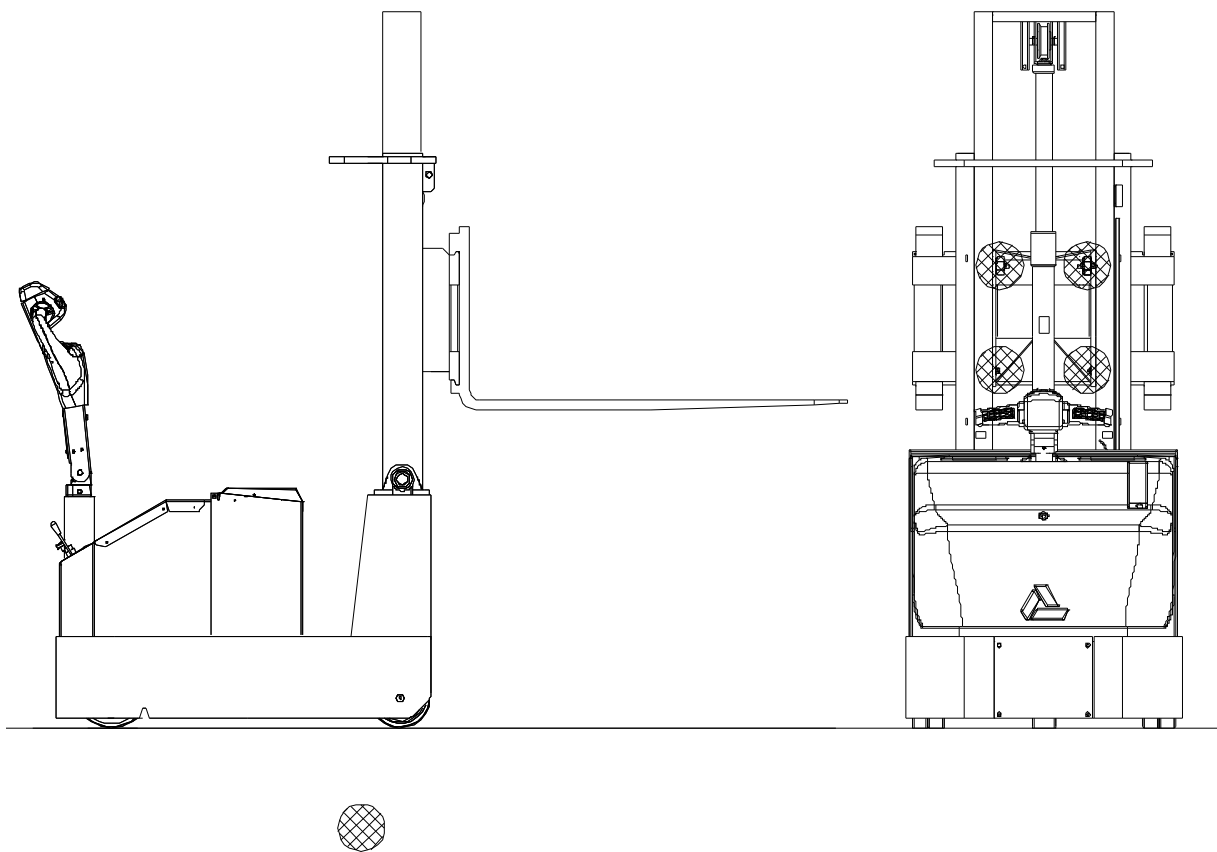

Fig. 5.1 Forks adjustment points

5.3 Danger zones

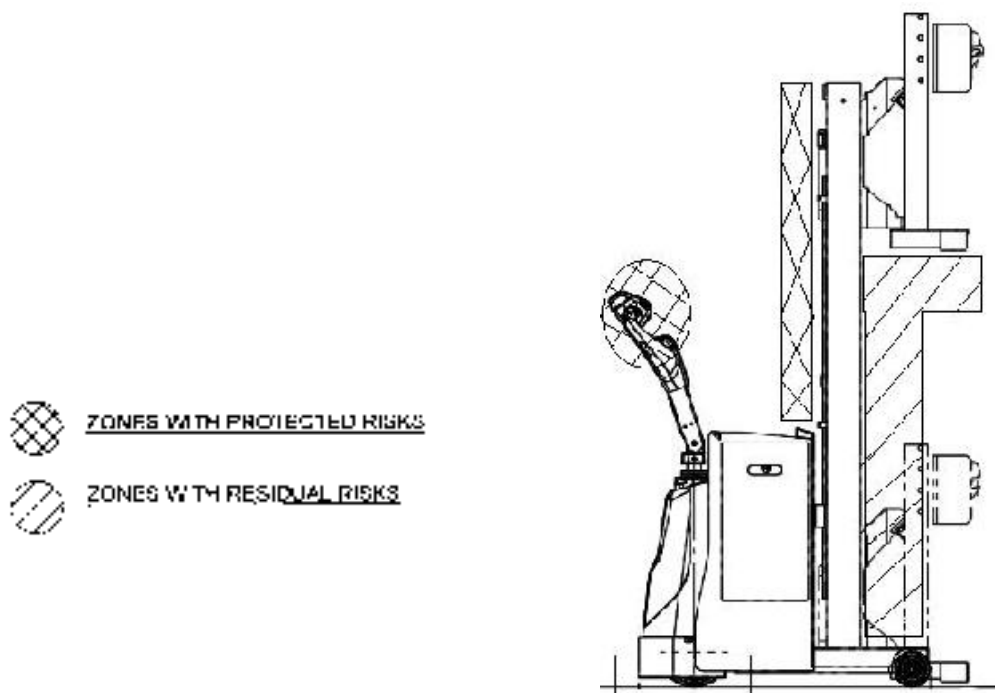

Fig. 5.2 Danger zones of the machine



DANGER

Carry out all maintenance operations when the machine is off and the switch is in (OFF) position.

5.4 Routine (periodical and preventive) maintenance

The routine maintenance operations are all those operations that are carried out at regular intervals so as to keep the machine always efficient.

5.4.1 Operator's qualification

- The routine maintenance operations can be carried out by the user in safe conditions after having read carefully all recommendations and instructions of this section.
- It is advisable for the machine user to take care of the machine maintenance as well.
- The maintenance operations can be carried out by using normal mechanical tools.

5.4.2 Cleaning

Cleaning products and tools

For the machine cleaning it is necessary to have:

- Plastic spatula
- Sponge or cloth
- Compressed air gun
- Protective glasses

Cleaning products

For the cleaning operations a normal detergent and non-potable water are sufficient.

Cleaning procedures

Prepare the machine for the cleaning.

- Lower the forks up to lower position
- With a plastic spatula, a sponge or a clean wet cloth remove the residual materials on the forks.
- Lift the forks up to the maximum height position
- Position the switch on (OFF)
- Clean the remainder of the machine.



ATTENTION

The truck must not be washed with bolts of water or steam cleaning machine. This operation may cause serious damages to the electric installation.

**DANGER**

Do not use any solvents since they damage the painting.

**ATTENTION**

Do not use a bolt of current water. The water could reach the motor and damage it.

5.4.3 Periodical inspections

Table 5.1 Periodical inspections of the lift truck

Parts to be inspected	Inspection frequency
Oil level	3 months
Lubrication of pivots and masts	1 month
Oil filter change	6 years
Oil replacement	6 years
Safety devices check	Every day
Battery acid level	Every day
Chains	3 months
General check of the truck by trained personnel (security devices, wear parts, etc.).	1 year

Oil replacement

In order to drain the oil from the tank, follow the instructions of the deactivation procedures in Chapter 6 concerning the oil drain. For the supply of the new oil refer to the previous paragraph.

Machine lubrication

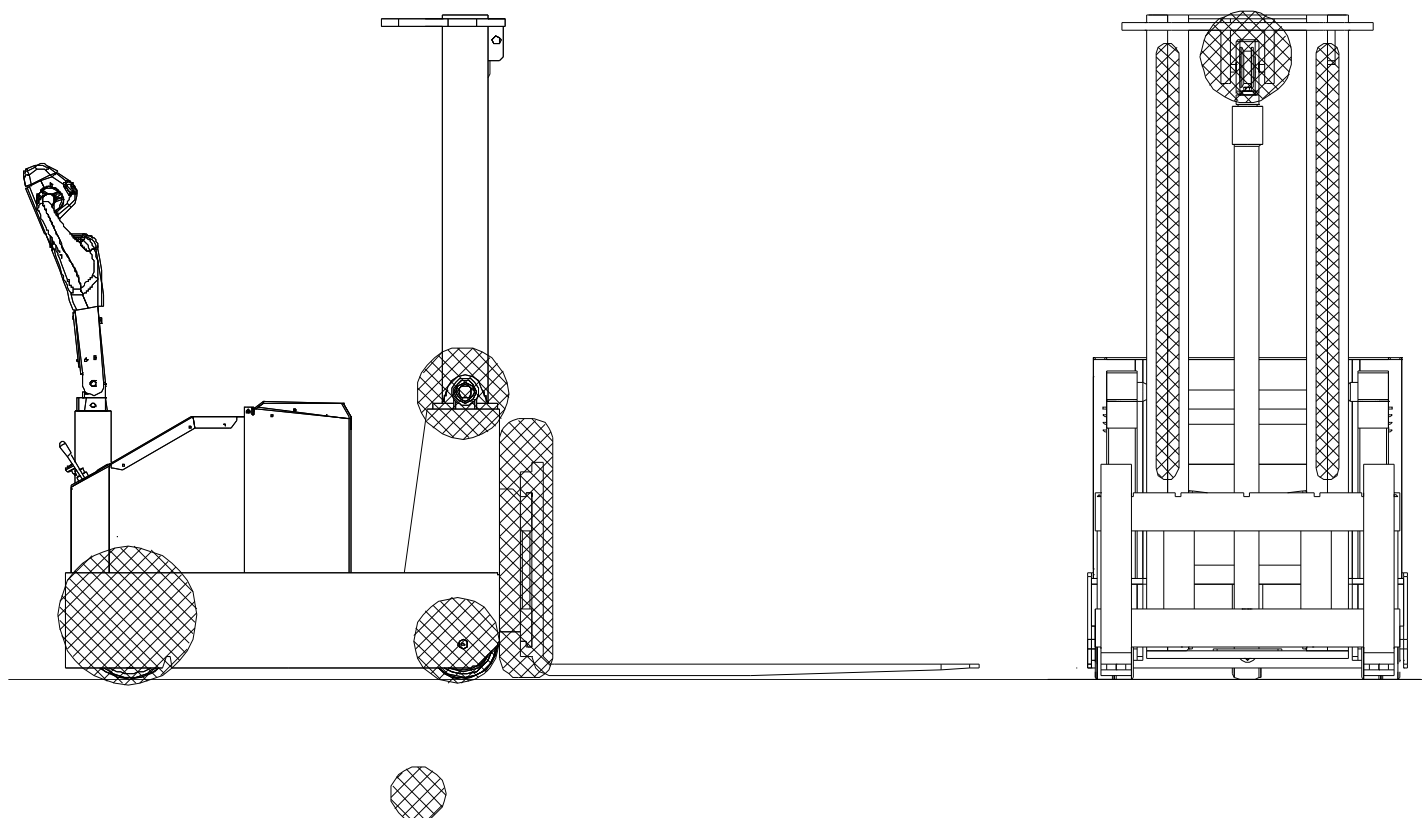

Fig. 5.3 Lubrication and greasing points

5.4.5 Special maintenance

The special maintenance includes all interventions specialised in mechanical, hydraulic or electric parts.

Contact the Technical Assistance for the repairs and supply of the spare parts.

NOTE The failures caused by a wrong maintenance or repairs carried out by unauthorised personnel are not included in the guarantee.

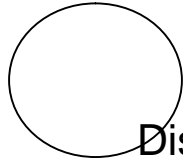

6.1 Machine deactivation

ARMANNI machines are designed and produced according to duration and flexibility criteria that allow their utilisation for several years. At the end of its technical and operating life, the machine shall be deactivated. The disability and deactivation of all the functions for which the machine had been designed and manufactured must allow the re-utilisation of its raw materials.

It is necessary to carry out a safe deactivation and dismantling of the machine so as to eliminate the following risks:

- Impact or squashing risks due to the presence of movable parts and stored energies (oil under pressure, forks in high position).
- Poisoning or environmental pollution risks due to the presence of oil in the hydraulic circuit.

NOTE

ARMANNI declines all responsibilities for damages to persons or things due to the re-utilisation of single parts of the machine for functions or assemble operations different from the original ones.

6.2 Deactivation procedures

In order to deactivate completely the machine do what follows:

- Lower the forks up to the lower position
- The truck is in the position in which it had been transported
- Disconnect the panel by positioning the switch on (OFF). Disconnect the battery
- Remove the sump and the instrument board
- Remove the oil tank and keep the oil inside a basin
-



DANGER

Give the oil to the Body in charge of the dismantling of the residual oils.
Give all the other materials (ferrous and nonferrous) to the bodies in charge of the recycle and dismantling

- Remove the battery
-



DANGER

Give the battery to the Body in charge of the dismantling of run-down batteries.

- Disassemble and remove the pump, the electromotor and the electric gearcase with the connection wires.
 - Reassemble the sump and the instrument board
 - Sling the truck by means of suitable holes and lift it in order to load it.
 - Carry the machine to destination.
-



ATTENTION

The deactivation and dismantling operations of the machine shall be carried out only by personnel adequately trained and equipped.



DANGER

If it should be necessary to remove the motorwheel, lift the machine and remove the wheel from underneath. Never remove the nylon bush positioned under the steering wheel before having extracted the motorwheel since underneath there is a high compression spring that could suddenly go out of the seat and cause serious damages to operators.

6.3 Hazards solved after the machine deactivation

If the machine deactivation procedure of this instruction handbook is followed accurately, all movable parts will be stopped; this will cause no residual risk.

