

MODEL LT-35**MODEL LT-40**

MODEL	LT-35	LT-40	LT-44	LT-48
Cap., lbs. — inch lbs.	(A) 1,500 — 38,500 (B) 2,000 — 51,500	3,000 — 79,500	4,000 — 106,000	4,000 — 142,000
Load Center	15"	15"	15"	24"
Lift Height	72" 84" 108" 120"	72" 84" 108" 120" 132"	72" 84" 108" 120" 132"	72" 84" 108" 120" 132"
Mast Height Lowered	64" 70" 82" 82"	65" 71" 83" 83" 95"	65" 71" 83" 83" 95"	65" 71" 83" 83" 95"
Mast Height Extended	96" 108" 132" 144"	97" 109" 133" 145" 157"	97" 109" 133" 145" 157"	97" 109" 133" 145" 157"
Free Lift	24" 24" 24" 12"	24" 24" 24" 12" 24"	24" 24" 24" 12" 24"	24" 24" 24" 12" 24"
Weight, lbs.	(A) 3000 3020 3060 3070 (B) 3390 3410 3450 3460	4380-4420-4490-4510-4560	5060-5090-5170-5200-5260	5780-5820-5900-5920-5980
Tilt	3 ¹ / ₂ ' Fwd., 10' Bkwd.	3 ¹ / ₂ ' Fwd., 10' Bkwd.	3 ¹ / ₂ ' Fwd., 10' Bkwd.	3 ¹ / ₂ ' Fwd., 10' Bkwd.
Length, Less Forks	59"	70"	74"	78 ¹ / ₂ "
Width, Overall	35"	37"	37"	37"
Wheelbase	35"	40"	44"	48"
Unde clearance	5"	6 ¹ / ₂ "	6 ¹ / ₂ "	6 ¹ / ₂ "
Carriage Rollers, No.	4	4	4	4
Carriage Width	35"	35"	35"	35"
Ht., Carr. Above Forks	23"	24"	24"	24"
Turning Radius, Out.	58"	68"	72"	76"
Turning Radius, In.	6"	6 ¹ / ₂ "	6"	9"
Turns in Inter. Axles	54"	63"	66"	69"
Speed of Travel	up to 7 mph	up to 7 mph	up to 7 mph	up to 7 mph
Speed of Lift, Loaded	35 F.P.M.	37 F.P.M.	37 F.P.M.	37 F.P.M.
Forks, Standard Length	30"	30"	36"	36"
Lateral Adj., In.-In.	5 ¹ / ₂ "	6 ¹ / ₂ "	6 ¹ / ₂ "	6 ¹ / ₂ "
Lateral Adj., Out.-Out.	33 ¹ / ₂ "	33"	33"	33"
Tread, Steer — Drive	27 ¹ / ₂ " — 29 ¹ / ₂ "	28 ¹ / ₂ " — 29 ¹ / ₂ "	28 ¹ / ₂ " — 30 ¹ / ₂ "	28 ¹ / ₂ " — 30 ¹ / ₂ "
Tires, Steer	12" x 3 ¹ / ₂ " x 8"	12" x 4" x 8"	12" x 4 ¹ / ₂ " x 8"	12" x 4 ¹ / ₂ " x 8"
Tires, Drive	16" x 3 ¹ / ₂ " x 12 ¹ / ₂ "	17" x 5" x 12 ¹ / ₂ "	17" x 6" x 12 ¹ / ₂ "	17" x 6" x 12 ¹ / ₂ "
Engine, Continental	N-62	Y-112	Y-112	Y-112

MODEL LT-44**MODEL LT-48**

MODEL LT-50

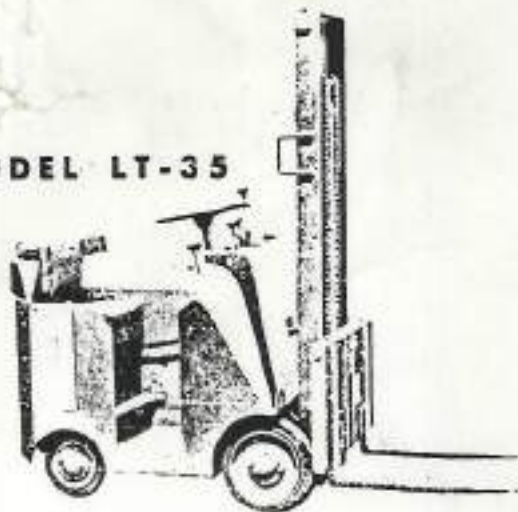
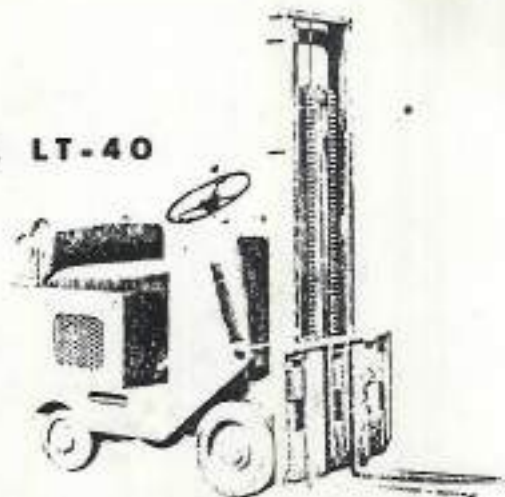
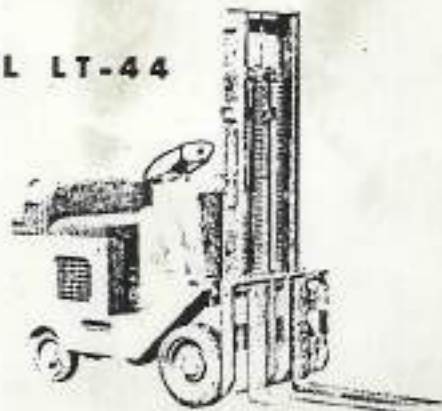

MODEL LT-56

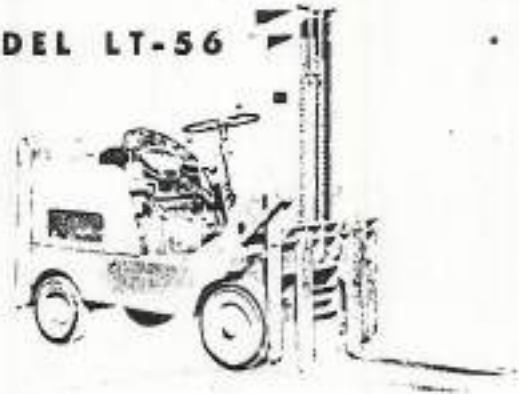

MODEL	LT-50	LT-56	LT-60
Cap., lbs. inch lbs.	5,000 - 175,000	5,000 - 240,000	(A) 4,000 - 183,000 (B) 5,000 - 229,000 (C) 6,000 - 278,000
Load Center	20"	25"	25"
Lift Height	72" 84" 108" 114" 144"	72" 84" 108" 114" 144"	72" 84" 108"
Max. Height Lowered	65" 71" 83" 83" 104"	65" 71" 83" 83" 104"	69" 75" 87"
Max. Height Extended	105" 117" 141" 147" 177"	105" 117" 141" 147" 177"	110" 122" 146"
Free Lift	15" 15" 15" 9" 21"	15" 15" 15" 9" 21"	12" 12" 12"
Weight, lbs.	7530-7590-7720-7740-7980	8415-8480-8610-8635-9000	(A) 7405 7470 7800 (B) 8025 8090 8220 (C) 8955 9030 9190
Til	3-1/2° Fwd., 10° Bkwd.	3-1/2° Fwd., 10° Bkwd.	3-1/2° Fwd., 10° Bkwd.
Length, Low Forks	80"	94"	106"
Width, Overall	42"	42"	55"
Wheelbase	50"	56"	60"
Underclearance	6"	7"	10 1/2"
Carriage Rollers, No.	4	4	4
Carriage Width	42"	42"	42"
Ht., Carr. Above Forks	32"	32"	37"
Turning Radius, Out.	81"	89"	A & B 125"; C 131"
Turning Radius, In.	21"	26"	A & B 50"; C 58"
Turns in Inter. Axles	60°	71°	90°
Speed of Travel	up to 8 mph	up to 8 mph	up to 11 mph
Speed of Lift, Lowered	40 F.P.M.	40 F.P.M.	45 F.P.M.
Forks, Standard Length	36"	42"	42"
Lateral Adj., In.-In.	8"	8"	8"
Lateral Adj., Out.-Out.	39"	39"	39"
Tires, Steer Drive	33 1/2" x 30 1/2"	34 1/2" x 30 1/2"	35" x 45"
Tires, Steer	17" x 5" x 12 1/2"	17" x 6" x 12 1/2"	A & B 6 5/8" x 10" C 7 3/8" x 10"
Tires, Drive	20" x 6" x 16"	20" x 4" x 16" dual	9.25 x 15"
Engine, Continental	F.162	F.162	F.209

MODEL LT-60

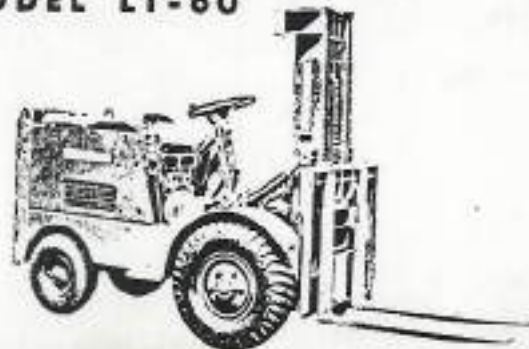

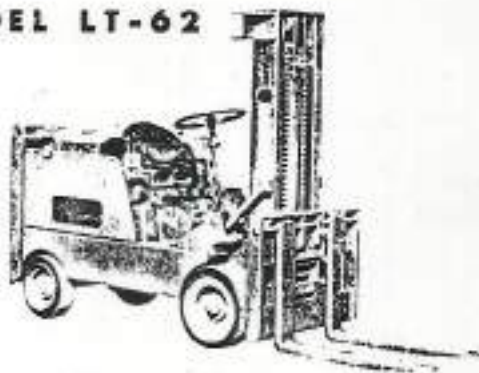
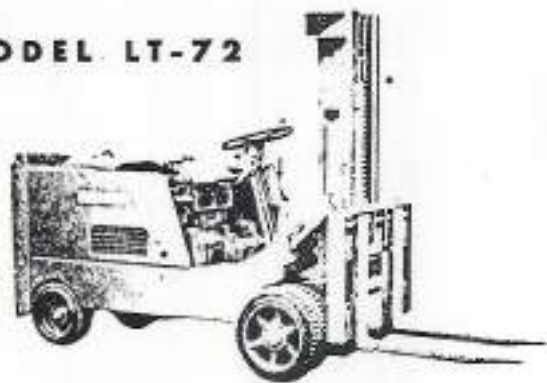
MODEL LT-62**MODEL LT-72**

MODEL	LT-62	LT-72	LT-90
Cap., lbs. — inch lbs.	7,000 — 287,000	10,000 — 410,000	15,000 — 675,000
Load Center	25"	25"	25"
Lift Height	72" 84" 104" 144"	74" 104"	74" 104"
Mast Height Lowered	67" 73" 83" 106"	71" 86"	60½" 95½"
Mast Height Extended	105" 117" 137" 177"	107" 137"	117½" 147½"
Free Lift	15" 15" 15" 21"	18" 18"	20½" 20½"
Weight, lbs.	9420 9490 9610 9900	12080 12350	16,300 16,700
Tilt	3°-8° Fwd., 10° Bkwd.	3°-8° Fwd., 10° Bkwd.	3° Fwd., 10° Bkwd.
Length, Less Forks	101"	112"	134½"
Width, Overall	42"	51"	58½"
Wheelbase	62"	72"	90"
Underclearance	7"	7"	8"
Carriage Rollers, No.	8	8	8
Carriage Width	42"	42"	57"
Ht. Carr. Above Forks	31"	31"	41½"
Turning Radius, Out.	97"	117"	145"
Turning Radius, In.	27"	27"	47"
Turns in Inter. Axles	78"	96"	112"
Speed of Travel	up to 8 mph	up to 8 mph	up to 5½ mph
Speed of Lift, Loaded	40 F.P.M.	34 F.P.M.	26 F.P.M.
Forks, Standard Length	42"	42"	42"
Lateral Adj., In.-In.	8"	8"	14"
Lateral Adj., Out.-Out.	39"	39"	54"
Tread, Steer—Drive	34½" — 32½"	34½" — 40"	35½" — 41½"
Tires, Steer	17" x 7" x 12½"	17" x 7" x 12½"	18" x 8" x 12½"
Tires, Drive	20" x 8" x 16" dual	20" x 8" x 16" dual	22" x 8" x 16" dual
Engine, Continental	F-209	F-209	F-225

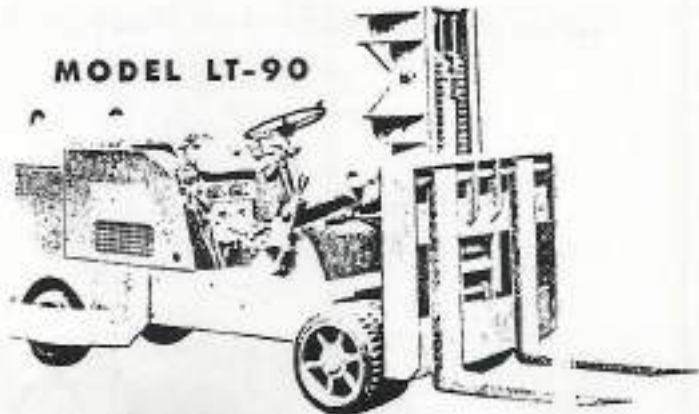
MODEL LT-90

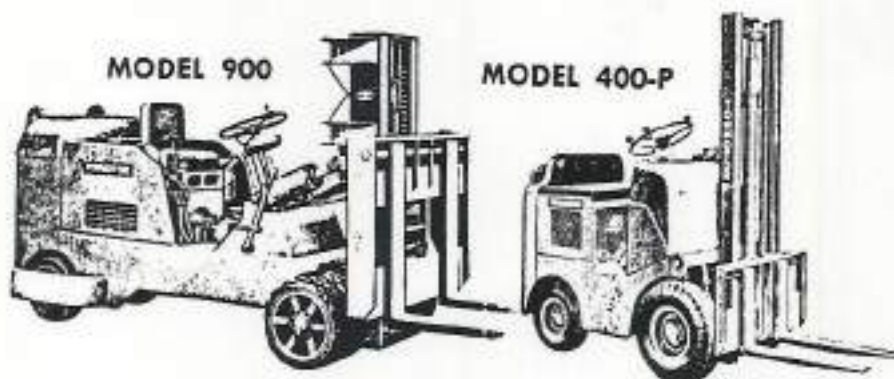

MODEL	900 900-LP	400-P 400-PLP
Capacity, lbs.—inch lbs.	(A) 15,000—660,000 (B) 18,000—798,000	2,000—79,000
Load Center	24"	24"
Lift Height	74" 104"	72" 108" 120"
Maximum Fork Height	76 1/4" 106 1/4"	73 1/2" 109 1/2" 121 1/2"
Mast Height Lowered	80" 95"	65" 83" 83"
Mast Height Extended	118" 145"	92" 120" 140"
Free Lift	22" 22"	21 1/2" 21 1/2" 21 1/2"
*Weight, lbs.	Gasoline: (A) 16,300 18,700 (B) 18,000 18,400 LP-Gas: (A) 16,350 16,750 (B) 18,050 18,450	Gasoline: 4510 4630 4650 LP-Gas: 4550 4610 4690
Tilt	3° Fwd., 10° Bkwd.	3° Fwd., 12° Bkwd.
Length, Less Forks	134"	74"
Width, Overall	58 1/2"	34 1/2"
Wheelbase	90"	40"
Underclearance	8"	7 1/2"
Carriage Rollers, No.	8	4
Carriage Width	57"	34"
Carriage Ht. Above Floor	44"	20"
Turning Radius, Outside	145"	32"
Turning Radius, Inside	43"	15 1/2"
Turns in Intersecting Aisles	104"	60 1/2"
Min. Aisle Right Angle Stacking	(A) 207" (B) 207 1/2"	117 1/2"
Speed of Travel	up to 5 1/2 mph	up to 9 mph
Speed of Lift, Loaded	27 F.P.M.	37 F.P.M.
Forks, Standard Length	42"	30"
Lateral Adj., In-In	10 1/2"	6 1/2"
Lateral Adj., Out-Out	54"	32"
Tread, Steer—Drive	34 1/2"—(A) 41 1/2", (B) 40 1/2"	27 1/2"—27 1/2"
Tires, Steer	18" x 8" x 12 1/2" Cushion	5.00" x 8" Pneumatic
Tires, Drive	(A) 22" x 8" x 16" Dual (B) 22" x 9" x 16" Cushion	6.50" x 10" Pneumatic
Drive Axle to Fork Face	(A) 20" (B) 20 1/2"	15 1/2"
Sole Height Above Floor	42 1/2"	41 1/2"
Ht. of Truck Exclusive of Mast	62 1/2" (LP-Gas, 65")	59 1/2" (LP-Gas, 61 1/2")
Gasoline & LPG Engine—Continental Diesel Engine—Continental	F-226	Y-112

MODEL 390

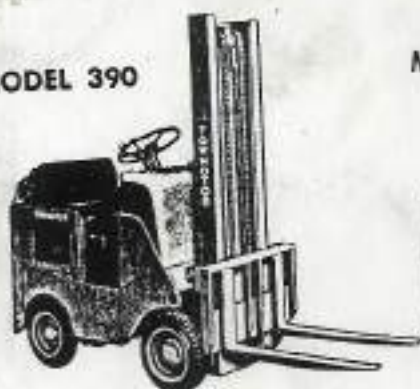

MODEL 420

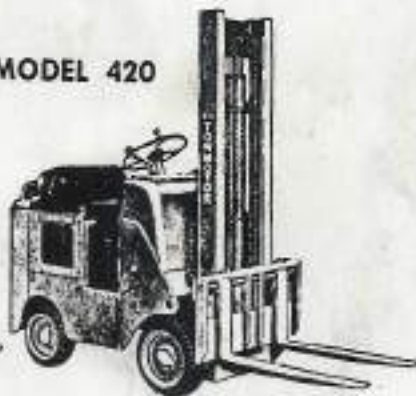

MODEL 460

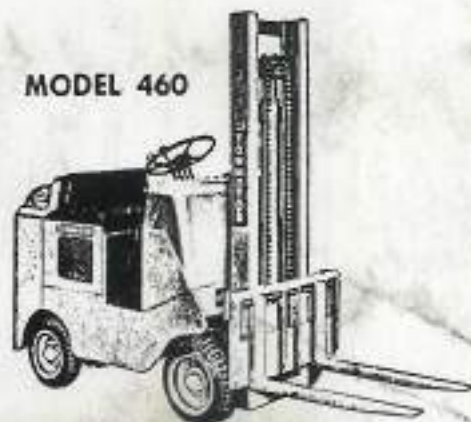

MODEL	390 390-LP	420 420-LP	460 460-LP 460-D
Cap., lbs.—inch lbs.	3,000—82,500	4,000—110,000	4,000—146,000
Load Center	15"	15"	24"
Lift Height	72" 108" 120" 144"	72" 108" 120" 144"	72" 108" 120" 144"
Max. Fork Height	74" 110" 122" 146"	74" 110" 122" 146"	74" 110" 122" 146"
**Max Height Lowered	65" 83" 83" 101"	65" 83" 83" 101"	65" 83" 83" 101"
***Max Height Extended	95" 128" 140" 164"	95" 128" 140" 164"	95" 128" 140" 164"
Free Lift	25 1/2" 25 1/2" 12 1/2" 25 1/2"	25 1/2" 25 1/2" 13 1/2" 25 1/2"	25 1/2" 25 1/2" 13 1/2" 25 1/2"
*Weight, lbs.	Gasoline: 4825-4975-5000-5125 LP-Gas: 4875-5015-5040-5165	Gasoline: 5350-5690-5715-5840 LP-Gas: 5600-5740-5765-5890	Gasoline: 6210-6350-6375-6500 LP-Gas: 6260-6400-6425-6550 Diesel: 6495-6585-6590-6715
Tilt	3°-5° Fwd., 10° Bkwd.	3°-5° Fwd., 10° Bkwd.	3°-5° Fwd., 10° Bkwd.
Length, Less Forks	21 1/4"	24 1/2"	28 1/2"
Width, Overall	32 3/4"	38 1/4"	38 1/2"
Wheelbase	39"	42"	46"
Underclearance	8 1/2"	7"	7 3/4"
Carriage Rollers, No.	4	4	4
Carriage Width	37"	37"	37"
Ht., Carr. Above Floor	20"	20"	20"
Turning Radius, Out	68"	71"	75"
Turning Radius, In	5"	5 1/2"	6"
Turn in Inter. Axles	61"	63 1/2"	65"
Min. Axle Right Angle Steering	110 1/2"	119 1/2"	122 1/2"
Speed of Travel	up to 8 mph	up to 8 mph	up to 8 mph
Speed of Lift, Loaded	37 F.P.M.	37 F.P.M.	37 F.P.M.
Forks, Standard Length	30"	36"	36"
Lateral Adj., In-In.	6 1/2"	6 1/2"	6 1/2"
Lateral Adj., Out-Out	25"	25"	25"
Tread, Steer—Drive	32 1/2"—31 3/4"	32 3/4"—31 1/4"	31 3/4"—31 1/4"
Tires, Steer	16 1/4" x 4" x 11 1/4" Cushion	16 1/4" x 5" x 11 1/4" Cushion	16 1/2" x 5" x 11 1/4" Cushion
Tires, Drive	17 1/4" x 6" x 10 1/4" Cushion	18" x 7" x 10 1/4" Cushion	18" x 7" x 10 1/4" Cushion
Drive Axle to Fork Face	12 1/2"	12 1/2"	12 1/2"
Seat Height Above Floor	42"	42"	42"
Ht. of Truck Excl. of Mast	58 1/2" (LP-Gas, 61 1/2")	58 1/2" (LP-Gas, 61 1/2")	58 1/2" (LP-Gas, 61 1/2")
Engine, Continental	Y-112	F-140	F-140 (Diesel: GD-137)

MODEL 500

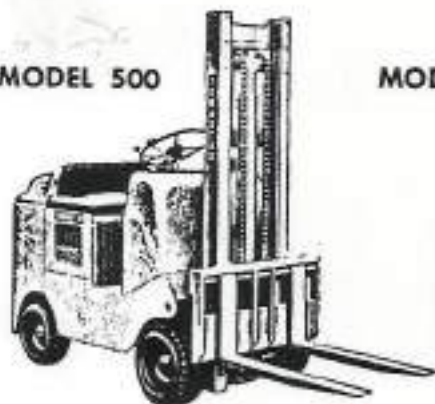

MODEL L500-P
500-P

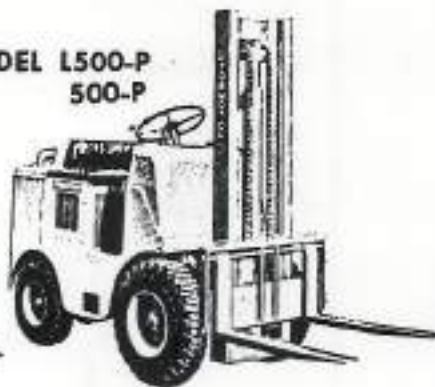

MODEL 680-P

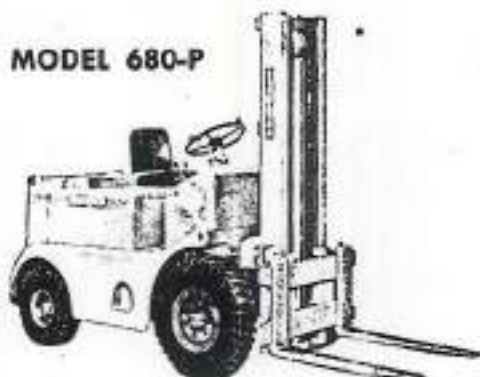

MODEL	500 500-LP 500-D	L500-F L500-PLP L500-PD	500-P 500-PLP 500-PD	680-P 680-PLP 680-PD
Cap., lbs.—inch lbs.	5,000—183,750	3,000—122,550	4,000—171,000	(A) 6,000—271,500 (B) 7,000—318,500
Load Center	24"	24"	24"	24"
Lift Height	72" 108" 120" 144"	78" 108" 120"	78" 108" 120"	84" 120" 144"
Max. Fork Height	74½" 110¼" 122¼" 146¼"	73½" 109½" 121½"	73½" 109½" 121½"	85" 121" 146"
**Mast Height Lowered	65" 83" 83" 101"	67" 85" 85"	67" 85" 85"	68" 86" 98"
**Mast Height Extended	75" 128" 140" 164"	92¼" 128¼" 140¼"	92¼" 128¼" 140¼"	111" 147" 171"
Free Lift	25¼" 25¼" 13¾" 15¾"	25½" 25½" 13½"	25¾" 25¾" 13¾"	17" 17" 17"
*Weight, lbs.	Gasoline: 7135-7375-7400-7525 LP-Gas: 7280-7420-7445-7570 Diesel: 7450-7590-7615-7740	6145 6195 6310 6195 6335 6360 6360 6500 6525	6785 6835 6950 6975 7000 7140 7165	Gasoline: 9365 9650 9840 (A) 9365 (B) 10275 10560 10750
Tilt	3°-5° Fwd., 10° Bkwd.	3°-5° Fwd., 10° Bkwd.	3°-5° Fwd., 10° Bkwd.	3°-5° Fwd., 10° Bkwd.
Length, Less Forks	88½"	85"	88½"	109¼"
Width, Overall	40¼"	41½"	41½"	A-53½"—B-72"
Wheelbase	50"	50"	50"	62"
Clearance	7½"	9½" (Diesel 8")	9½" (Diesel 8")	10½"
Carriage Rollers, No.	4	4	4	4
Carriage Width	31"	41"	41"	43"
Ht., Cav. Above Floor	50"	50¼"	50¼"	A-27"—B-26¾"
Turning Radius, Out	81"	85½"	87"	110"
Turning Radius, In	103¼"	18"	18"	A-20"—B-11"
Turns in Inter. Axles	69"	10½"	73½"	A-89¾"—B-96¼"
Min. Aisle Right Angle Stacking	129¾"	140¼"	141¾"	A-173¼"—B-173¾"
Speed of Travel	up to 8 mph	up to 10 mph	up to 10 mph	up to 11.5 mph
Speed of Lift, Loaded	37 F.P.M.	37 F.P.M.	37 F.P.M.	35 F.P.M.
Forks, Standard Length	36"	36"	36"	42"
Lateral Adj., In-In	5½"	6½"	6½"	0"
Lateral Adj., Out-Out	35"	39"	39"	43"
Tread, Steer—Drive	32¼"—35¼"	30¼"—34"	30¼"—34"	A-42¼"—45" B-42¼"—54¾"
Tires, Steer	16¼" x 6" x 11½" Cushion	6.50" x 10" Pneumatic	6.50" x 10" Pneumatic	7.50" x 10" Pneumatic
Tires, Drive	18" x 8" x 12¼" Cushion	7.00" x 12" Pneumatic	7.00" x 12" Pneumatic	(A) 8.25" x 15"—Pneumatic (B) 7.50" x 15"—Dual Pneumatic
Drive Axle to Fork Face	19¼"	18½"	18½"	A-21¼"—B-21¼"
Seat Height Above Floor	42"	46"	45"	51¾"
Ht. of Truck Excl. of Mast	58¼" (LP-Gas, 61¼")	62¼" (LP Gas, 64")	62¼" (LP-Gas, 63¼")	69"
Engine, Continental	F-140 (Diesel: GD-157)	F-140 (Diesel: GD-157)	F-140 (Diesel: GD-157)	F-209 (Diesel: HD-260)

MODEL 350

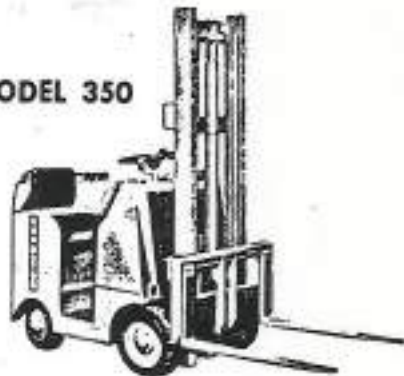

MODEL 391



**410
MODEL 440**

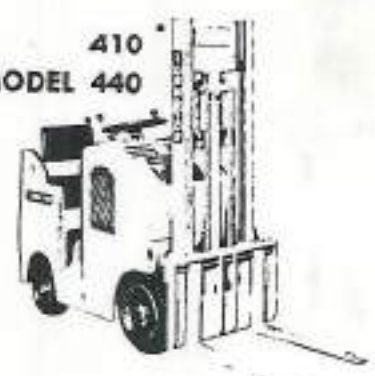

Unless otherwise noted, individual model specifications are the same for all applicable power types.

MODEL	350 350-LP	391 391-LP	410 410-LP	440 440-LP
Capacity, lbs.—inch lbs.	(A) 1,500—39,750 (B) 2,000—53,000 (C) 2,000—71,000	3,000—42,500	2,000—19,750	3,000—113,250
Load Center	(A&B) 15" (C) 24"	15"	24"	24"
Lift Height	75" 84" 108" 120"	72" 108" 120" 144"	75" 108" 120" 144"	72" 108" 120" 144"
Maximum Park Height	74" 86" 110" 122"	74" 110" 122" 146"	74" 110" 122" 146"	74" 110" 122" 146"
Max Height Lowered	65" 71" 83" 83"	65" 83" 83" 101"	65" 83" 83" 101"	65" 83" 83" 101"
Max Height Extended	95½" 104½" 128½" 140½"	90" 128" 140" 164"	95½" 128½" 140½" 164½"	95½" 128½" 140½" 164½"
Free Lift	25½" 25½" 25½" 13½"	25½" 25½" 13½" 25½"	25½" 25½" 13½" 25½"	25½" 25½" 13½" 25½"
*Weight, lbs.	Gasoline: (A) 3095 3120 3170 3180 (B) 3405 3430 3580 3640 (C) 4130 4150 4190 4200	Gasoline: 4835 4975 5000 5125 LP-Gas: 4875 5015 5040 5165	Gasoline: 4615 4675 4685 4745 LP-Gas: 4655 4715 4725 4785	Gasoline: 5810 5950 6075 6000 LP-Gas: 5855 5995 6120 6045
Tilt	3°-5° Fwd., 10° Bkwd.	3°-5° Fwd., 10° Bkwd.	3°-5° Fwd., 10° Bkwd.	3°-5° Fwd., 10° Bkwd.
Length, Lash Forks	(A&B) 60½" (C) 61½"	71½"	70½"	74½"
Width, Overall	35"	37½"	38"	35½"
Wheelbase	35"	39"	41"	44"
Underclearance	5"	8½"	4½"	4½"
Carriage Rollers, No.	4	4	4	4
Carriage Width	35"	37"	38"	39"
Carriage Ht. Above Floor	20½"	20"	20½"	20½"
Turning Radius, Outside	(A&B) 58" (C) 60½"	68"	61½"	65½"
Turning Radius, Inside	5"	5"	1½"	1½"
Turns in Intersecting Aisles	(A&B) 55" (C) 56"	61"	56"	60½"
Min. Aisle Right Angle Stacking	(A&B) 99½" (C) 102"	110½"	104½"	115"
Speed of Travel	up to 8 mph	up to 8 mph	up to 9 mph	up to 9 mph
Speed of Lift, Loaded	40 F.P.M.	48 F.P.M.	85 F.P.M.	75 F.P.M.
Forks, Standard Length	30"	30"	30"	36"
Lateral Adj., in-in.	5½"	6½"	5½"	6½"
Lateral Adj., Out-Out	33"	35"	29½"	29½"
Tread, Steer—Drive	28½"—28½"	22½"—31½"	27"—27"	27"—29½"
Tires, Steer	13" x 3½" x 8" Cushion	16½" x 4" x 11½" Cushion	13" x 3½" x 8" Cushion	13" x 4½" x 8" Cushion
Tires, Drive	17" x 4½" x 12½" Cushion	17½" x 6" x 12½" Cushion	17½" x 5" x 12½" Cushion	17½" x 6" x 12½" Cushion
Drive Axle to Fork Face	11½"	12½"	12½"	13½"
Seat Height Above Floor	22½"	42"	32"	32"
Ht. of Truck Exclusive of Mast	50½"	60" (LP Gas, 61½")	48"	48"
Gasoline & LPG Engine—Continental Diesel Engine—Continental	N-55	Y-112	Y-112	Y-112

M EL 421

MODEL L461

MODEL 461

MODEL 501

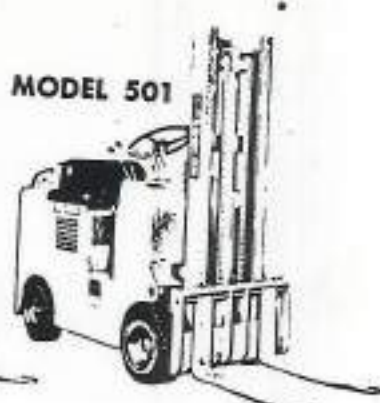
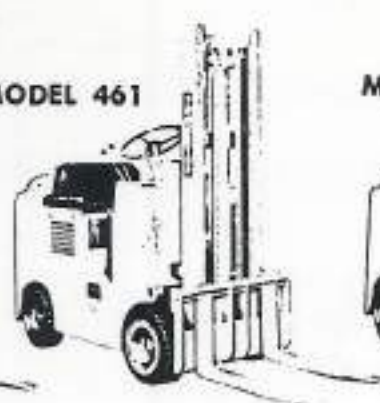
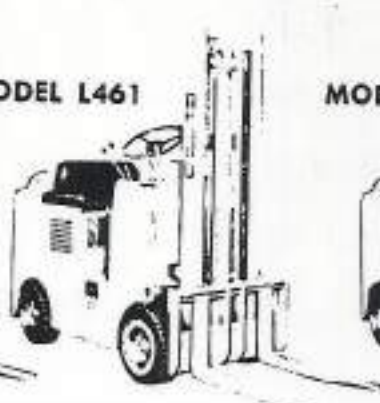
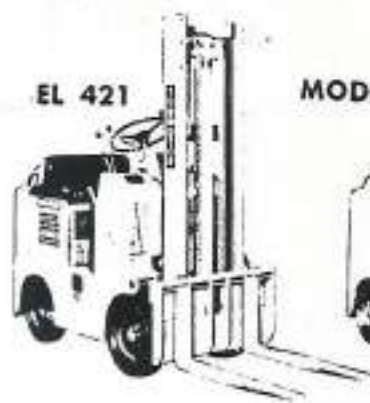

MODEL	421 421-LP	L461 L461-LP L461-D	461 461-LP 461-D	501 501-LP 501-D
Capacity, lbs.—inch lbs.	4,000—110,000	3,000—109,500	4,000—146,000	5,000—183,750
Load Center	15"	24"	24"	24"
Lift Height	78" 110" 120" 144"	78" 108" 120" 144"	70" 108" 120" 144"	78" 108" 120" 144"
Minimum Fork Height	74" 110" 120" 146"	74" 110" 120" 146"	74" 110" 122" 146"	74½" 110½" 122½" 146½"
Max Height Lowered	65" 83" 83" 101"	65" 83" 83" 101"	65" 83" 83" 101"	65" 83" 83" 101"
Max Height Extended	92" 118" 140" 164"	92" 128" 140" 164"	92" 128" 140" 164"	92" 128" 140" 164"
Free Lift	25½" 15½" 13½" 25½"	25½" 25½" 13½" 25½"	25½" 25½" 13½" 25½"	25½" 25½" 13½" 25½"
*Weight, lbs.	Gasoline: 3390 3690 5715 3840 LP-Gas: 3600 3740 5765 3890	Gasoline: 5285 5475 5450 5575 LP-Gas: 5335 5475 5500 5625 Diesel: 5500 5640 5665 5790	Gasoline: 6210 6350 6375 6500 LP-Gas: 6260 6400 6425 6550 Diesel: 6425 6565 6590 6715	Gasoline: 7235 7375 7400 7595 LP-Gas: 7280 7420 7445 7570 Diesel: 7450 7590 7615 7740
Tilt	3°-5° Fwd., 10° Bkwd.	3°-5° Fwd., 10° Bkwd.	3°-5° Fwd., 10° Bkwd.	3°-5° Fwd., 10° Bkwd.
Length, Less Forks	74½"	78¾"	78¾"	82¾"
Width, Overall	38½"	38¾"	38½"	40¾"
base	42"	46"	46"	50"
Underclearance	7¼"	7¾"	7¾"	7¾"
Carriage Rollers, No.	4	4	4	4
Carriage Width	37"	37"	37"	37"
Carriage Ht. Above Floor	20"	20"	20"	20"
Turning Radius, Outside	71"	75"	75"	81"
Turning Radius, Inside	5½"	6"	6"	10¾"
Turns in Intersecting Aisles	63½"	65"	65"	69"
Min. Aisle Right Angle Stacking	119½"	123½"	123½"	129½"
Speed of Travel	up to 8 mph	up to 8 mph	up to 8 mph	up to 8 mph
Speed of Lift, Loaded	50 F.P.M.	50 F.P.M.	50 F.P.M.	48 F.P.M.
Forks, Standard Length	36"	36"	36"	36"
Lateral Adj., In-In	6½"	6½"	6½"	6½"
Lateral Adj., Out-Out	35"	35"	35"	35"
Travel, Steer—Drive	21¾" — 31¼"	21¾" — 31¼"	21¾" — 31¼"	25¾" — 25¾"
Tires, Steer	16¼" x 5" x 11¼" Cushion	16¼" x 5" x 11¼" Cushion	16¼" x 5" x 11¼" Cushion	16¼" x 6" x 11¼" Cushion
Tires, Drive	18" x 7" x 12½" Cushion	18" x 7" x 12½" Cushion	18" x 7" x 12½" Cushion	18" x 8" x 12½" Cushion
Drive Axle to Fork Floor	19½"	19½"	19½"	19½"
Sole Height Above Floor	43½"	43½"	43½"	43½"
Ht. of Truck Exclusive of Mast	60" (LP-Gas, 61½")	60" (LP-Gas, 61½")	60" (LP-Gas, 61½")	60" (LP-Gas, 61½")
Gasoline & LPG Engine—Continental Diesel Engine—Continental	F-140	F-140 GD-157	F-140 GD-157	F-140 GD-157

MODEL 540



MODEL 600

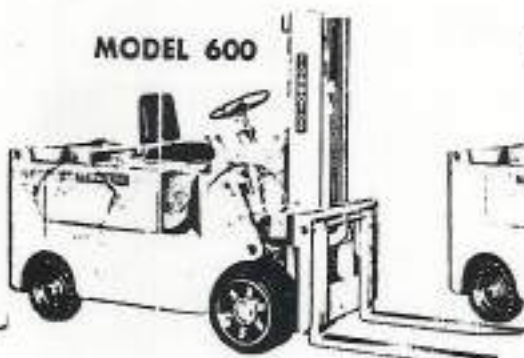

MODEL 670

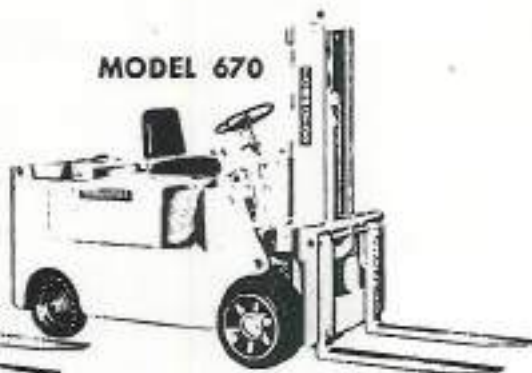

MODEL	540 540-LP 540-D	600 600-LP 600-D	670 670-LP 670-D	
Capacity, lbs.—inch lbs.	(A) 6,000—236,250 (B) 7,000—275,625	(A) 8,000—315,000 (B) 9,000—356,625	(A) 10,000—396,250 (B) 11,000—435,675	12,000—481,500
Load Center	34"	34"	34"	34"
Lift Height	84" 120" 144"	84" 108" 144"	74" 98" 144"	74" 98" 144"
Maximum Fork Height	85½" 121½" 145½"	86" 110" 140"	76" 100" 140"	76½" 100½" 140½"
Mast Height Lowered	65" 83" 95"	71" 83" 101"	71" 83" 106"	75" 87" 110"
Mast Height Extended	108½" 144½" 168½"	116½" 140½" 176"	105½" 129½" 175½"	110½" 134½" 180½"
Free Lift	16½" 16½" 16½"	26½" 26½" 26"	36½" 36½" 35½"	14" 14" 14"
*Weight, lbs.	Gasoline: (A) 9095 9380 9570 (B) 9945 10230 10420	Gasoline: (A) 11000 11190 11475 (B) 11740 11930 11915	Gasoline: (A) 12240 12430 12795 (B) 13140 13330 13695	Gasoline: 14,710 14,900 15,265
Tilt	3°-5° Fwd., 10° Bkwd.	3°-5° Fwd., 10° Bkwd.	3°-5° Fwd., 10° Bkwd.	3°-5° Fwd., 10° Bkwd.
Length, Less Forks	(A) 91½" (B) 93½"	(A) 99½" (B) 100½"	107½"	107½"
Width, Overall	44"	(A) 44½" (B) 46"	50½"	50½"
Wheelbase	54"	60"	67"	67"
Underclearance	6½"	6½"	6½"	6½"
Carriage Rollers, No.	4	4	4	4
Carriage Width	44"	44"	44"	44"
Carriage Ht. Above Floor	24½"	23½"	31½"	36½"
Turning Radius, Outside	(A) 85" (B) 87"	(A) 93½" (B) 94½"	102"	102"
Turning Radius, Inside	4"	(A) 6½" (B) 5½"	5½"	5½"
Turns in Intersecting Aisles	(A) 74½" (B) 75½"	(A) 79" (B) 79½"	85½"	86"
Min. Aisle Right Angle Stacking	(A) 142½" (B) 144½"	(A) 150½" (B) 150½"	159½"	160½"
Speed of Travel	up to 9 mph	up to 9 mph	up to 8 mph	up to 8 mph
Speed of Lift, Loaded	(A) 50 F.P.M. (B) 45 F.P.M.	50 F.P.M.	45 F.P.M.	45 F.P.M.
Forks, Standard Length	48"	48"	48"	48"
Lateral Adj., In-In	¾"	1½"	1½"	1½"
Lateral Adj., Out-Out	41½"	41½"	41½"	41½"
Tread, Steer—Drive	37½"—36"	37½"—34"	31½"—(A) 40", (B) 38½"	37½"—38½"
Tires, Steer	17½" x 6" x 12½" Cushion	18" x 7" x 12½" Cushion	18" x 7" x 12½" Cushion	18" x 7" x 12½" Cushion
Tires, Drive	22" x 8" x 16" Cushion	(A) 22" x 5" x 16" (Dual) (B) 22" x 6" x 16" (Cushion)	(A) 22" x 6" x 16" (Dual) (B) 22" x 7" x 16" (Cush.)	22" x 7" x 16" Dual Cushion
Drive Axle to Fork Face	153½"	(A) 15½" (B) 153½"	15½"	16½"
Seat Height Above Floor	47"	47"	47"	47"
Ht. of Truck Exclusive of Mast	63½"	63½"	63½"	63½"
Gasoline & LPG Engine—Continental Diesel Engine—Continental	F-209 HD-260	F-209 HD-260	F-209 HD-260	F-209 HD-260

*MODEL 351S

Model 350S

Model 411S

Model 441S



MODEL	350SG2015	350SG2024	411SG2024	411SG3015	411SG3024	441SG4015
Capacity, lbs.	2000	2000	2000	3000	3000	4000
Load Center	35"	24"	24"	15"	24"	15"
Fach-Pound Rating	53,250	71,250	71,250	82,875	113,250	115,000
Centerline of Drive Axle to Fork Face	11 $\frac{1}{2}$ "	11 $\frac{1}{2}$ "	12 $\frac{3}{4}$ "	12 $\frac{1}{2}$ "	13 $\frac{1}{2}$ "	13 $\frac{1}{2}$ "
Maximum Lift Height with Rated Load (1)	144"	144"	144"	144"	144"	144"
Maximum Fork Height	145"	145"	146"	146"	146"	146"
Mast Lowered Height	90"	90"	90"	90"	90"	90"
Mast Extended Height (Less Load Backrest With Load Backrest	164 $\frac{1}{2}$ " 194"	164 $\frac{1}{2}$ " 194"	164 $\frac{1}{2}$ " 193 $\frac{1}{2}$ "	164 $\frac{1}{2}$ " 193 $\frac{1}{2}$ "	164 $\frac{1}{2}$ " 194"	164 $\frac{1}{2}$ " 194"
Free Lift	18"	18"	18"	18"	17 $\frac{1}{2}$ "	17 $\frac{1}{2}$ "
Truck Weight, lbs.	4070	4435	4850	5230	6255	6480
Tilt—Degree (Forward Backward	5 10	5 10	5 10	5 10	5 10	5 10
Speed of Lift, Loaded	45 fpm	45 fpm	95 fpm	95 fpm	75 fpm	75 fpm
Speed of Travel	Up to 8.0 mph	Up to 8.0 mph	Up to 5.0 mph	Up to 9.0 mph	Up to 9.0 mph	Up to 9.0 mph
Carriage Width	35"	35"	32"	32"	32"	32"
Carriage Height (Less Load Backrest With Load Backrest	20 $\frac{1}{2}$ " 50"	20 $\frac{1}{2}$ " 50"	20 $\frac{1}{2}$ " 49 $\frac{1}{2}$ "	20 $\frac{1}{2}$ " 49 $\frac{1}{2}$ "	20 $\frac{1}{2}$ " 50"	20 $\frac{1}{2}$ " 50"
Forks, Standard Section and Length	1 $\frac{1}{2}$ " x 4" x 30"	1 $\frac{1}{2}$ " x 4" x 30"	1 $\frac{1}{2}$ " x 4" x 30"	1 $\frac{1}{2}$ " x 4" x 30"	1 $\frac{1}{2}$ " x 4" x 36"	1 $\frac{1}{2}$ " x 4" x 36"
Lateral Adjustment, In to In	1 $\frac{1}{4}$ "	1 $\frac{1}{4}$ "	1 $\frac{1}{4}$ "	1 $\frac{1}{4}$ "	6 $\frac{1}{2}$ "	6 $\frac{1}{2}$ "
Lateral Adjustment, Out to Out	33 $\frac{1}{2}$ "	33 $\frac{1}{2}$ "	30 $\frac{1}{2}$ "	30 $\frac{1}{2}$ "	29 $\frac{1}{2}$ "	29 $\frac{1}{2}$ "
Turning Radius (Outside Inside	59" 4"	59" 4"	61 $\frac{1}{2}$ " 1 $\frac{1}{2}$ "	61" 1"	67" 1 $\frac{1}{4}$ "	67" 1 $\frac{1}{4}$ "
Minimum Intersecting Axle	54 $\frac{1}{2}$ "	54 $\frac{1}{2}$ "	56"	58"	61 $\frac{1}{2}$ "	61 $\frac{1}{2}$ "
Minimum Axle for Right Angle Stacking Less Load Length	70 $\frac{1}{2}$ "	70 $\frac{1}{2}$ "	74 $\frac{1}{2}$ "	75 $\frac{1}{2}$ "	80 $\frac{1}{2}$ "	80 $\frac{1}{2}$ "
Overall Width	35 $\frac{1}{2}$ "	35 $\frac{1}{2}$ "	32"	32"	35 $\frac{1}{2}$ "	35 $\frac{1}{2}$ "
Wheelbase	35"	35"	41"	41"	44"	44"
Overall Length, Less Forks and Towing Eye	61 $\frac{1}{2}$ "	61 $\frac{1}{2}$ "	70 $\frac{1}{2}$ "	72"	76 $\frac{1}{2}$ "	76 $\frac{1}{2}$ "
Driver's Overhead Guard Height	83"	83"	71 $\frac{1}{2}$ "	71 $\frac{1}{2}$ "	71 $\frac{1}{2}$ "	71 $\frac{1}{2}$ "
Effective Seat Height	32 $\frac{1}{2}$ "	32 $\frac{1}{2}$ "	32"	32"	32"	32"
Tread, Steer—Drive	28 $\frac{1}{2}$ "-29 $\frac{1}{2}$ "	28 $\frac{1}{2}$ "-29 $\frac{1}{2}$ "	27"-27"	27"-27"	27"-29 $\frac{1}{4}$ "	27"-29 $\frac{1}{4}$ "
Tire Size, Steer	13" x 3 $\frac{1}{2}$ " x 8"	13" x 3 $\frac{1}{2}$ " x 8"	13" x 3 $\frac{1}{2}$ " x 8"	13" x 4 $\frac{1}{2}$ " x 8"	13" x 4 $\frac{1}{2}$ " x 8"	13" x 4 $\frac{1}{2}$ " x 8"
Tire Size, Drive	17" x 4 $\frac{1}{2}$ " x 12 $\frac{1}{2}$ "	17" x 4 $\frac{1}{2}$ " x 12 $\frac{1}{2}$ "	17 $\frac{1}{2}$ " x 5" x 12 $\frac{1}{2}$ "	17 $\frac{1}{2}$ " x 5" x 12 $\frac{1}{2}$ "	18" x 6" x 12 $\frac{1}{2}$ "	18" x 6" x 12 $\frac{1}{2}$ "
Underclearance, Center of Truck	5 $\frac{1}{4}$ "	5 $\frac{1}{4}$ "	4 $\frac{1}{2}$ "	4 $\frac{1}{2}$ "	4 $\frac{1}{2}$ "	4 $\frac{1}{2}$ "
Engine, Continental Model	N-62	N-62	Y-112	Y-112	Y-112	Y-112
Optional Power Types Available	LP-Gas	LP-Gas	LP-Gas	LP-Gas	LP-Gas	LP-Gas

* Engine: Waukesha, ICK

Model 392S

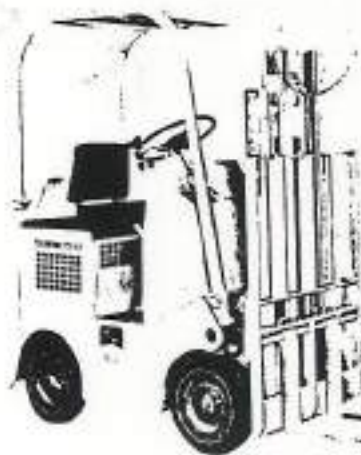

Model 422S

Model 462S
Model 502S

MODEL	392SG2024	392SG2524	422SG3024	422SG4015	462SG4024	502SG5024
Capacity, lbs.	2000	2500	3000	4000	4000	5000
Load Center	24"	24"	24"	15"	24"	24"
Inch-Pound Rating	71,750	91,250	130,000	110,000	146,000	183,750
Centerline of Drive Axle to Fork Face	21 $\frac{3}{8}$ "	22 $\frac{1}{2}$ "	22 $\frac{1}{2}$ "	22 $\frac{3}{8}$ "	22 $\frac{3}{8}$ "	22 $\frac{3}{8}$ "
Maximum Lift Height with Rated Load (1)	144"	144"	144"	144"	144"	144"
Maximum Fork Height	146"	146"	146"	146"	146"	146 $\frac{1}{2}$ "
Max Lowered Height	90"	90"	90"	90"	90"	90"
Max Extended Height { Less Load Backrest With Load Backrest	164 $\frac{1}{2}$ " 194"	164 $\frac{1}{2}$ " 194"	164 $\frac{1}{2}$ " 194"	164 $\frac{1}{2}$ " 194"	164 $\frac{1}{2}$ " 194"	164 $\frac{1}{2}$ " 194"
Free Lift	18"	17 $\frac{1}{2}$ "	17 $\frac{1}{2}$ "	17 $\frac{1}{2}$ "	17 $\frac{1}{2}$ "	17 $\frac{1}{2}$ "
Truck Weight, lbs.	4055	5425	5825	5825	6665	7680
Tilt—Degrees { Forward Backward	5 10	5 10	5 10	5 10	5 10	5 10
Speed of Lift, Loaded	110 fpm	80 fpm	90 fpm	90 fpm	80 fpm	80 fpm
Speed of Travel	Up to 8.0 mph	Up to 8.0 mph	Up to 8.0 mph	Up to 8.0 mph	Up to 8.0 mph	Up to 8.0 mph
Carriage Width	35"	37"	37"	37"	37"	37"
Carriage Height { Less Load Backrest With Load Backrest	20 $\frac{3}{4}$ " 50"	20 $\frac{3}{4}$ " 50"	20 $\frac{3}{4}$ " 50"	20 $\frac{3}{4}$ " 50"	20 $\frac{3}{4}$ " 50"	20 $\frac{3}{4}$ " 50"
Forks, Standard Section and Length	1 $\frac{1}{2}$ " x 4" x 30"	1 $\frac{1}{2}$ " x 4" x 30"	1 $\frac{1}{2}$ " x 4" x 36"	1 $\frac{1}{2}$ " x 4" x 36"	1 $\frac{1}{2}$ " x 4" x 36"	1 $\frac{1}{2}$ " x 4" x 36"
Lateral Adjustment, In to In	1 $\frac{1}{2}$ "	6 $\frac{1}{2}$ "	6 $\frac{1}{2}$ "	6 $\frac{1}{2}$ "	6 $\frac{1}{2}$ "	6 $\frac{1}{2}$ "
Lateral Adjustment, Out to Out	33 $\frac{3}{8}$ "	34 $\frac{3}{8}$ "	34 $\frac{3}{8}$ "	34 $\frac{3}{8}$ "	34 $\frac{3}{8}$ "	34 $\frac{3}{8}$ "
Turning Radius { Outside Inside	68" 5 $\frac{1}{4}$ "	68 $\frac{3}{8}$ " 5"	71" 5 $\frac{1}{2}$ "	71" 5 $\frac{1}{2}$ "	75" 6"	81" 10 $\frac{1}{4}$ "
Minimum Intersecting Aisle	60 $\frac{1}{2}$ "	61 $\frac{1}{2}$ "	63 $\frac{1}{2}$ "	63 $\frac{1}{2}$ "	65"	69"
Minimum Aisle for Right Angle Stacking Less Load Length	79 $\frac{3}{8}$ "	80 $\frac{3}{8}$ "	83 $\frac{1}{8}$ "	83 $\frac{1}{8}$ "	87 $\frac{1}{8}$ "	93 $\frac{1}{8}$ "
Overall Width	37 $\frac{1}{2}$ "	37 $\frac{3}{4}$ "	38 $\frac{1}{4}$ "	38 $\frac{1}{4}$ "	38 $\frac{1}{4}$ "	40 $\frac{1}{4}$ "
Wheelbase	39"	39"	42"	42"	46"	50"
Overall Length, Less Forks and Towing Eye	70 $\frac{3}{4}$ "	72 $\frac{3}{4}$ "	74 $\frac{3}{4}$ "	74 $\frac{3}{4}$ "	79 $\frac{3}{4}$ "	82 $\frac{3}{4}$ "
Driver's Overhead Guard Height	81 $\frac{1}{2}$ "	81 $\frac{1}{2}$ "	81 $\frac{1}{2}$ "	81 $\frac{1}{2}$ "	81 $\frac{1}{2}$ "	81 $\frac{1}{2}$ "
Effective Seat Height	40 $\frac{1}{4}$ "	40 $\frac{1}{2}$ "	40 $\frac{1}{2}$ "	40 $\frac{1}{4}$ "	40 $\frac{1}{4}$ "	40 $\frac{1}{2}$ "
Tread, Steer—Drive	32 $\frac{1}{2}$ "-32 $\frac{1}{2}$ "	32 $\frac{1}{2}$ "-31 $\frac{1}{2}$ "	31 $\frac{3}{4}$ "-31 $\frac{1}{4}$ "	31 $\frac{3}{4}$ "-31 $\frac{1}{4}$ "	31 $\frac{1}{2}$ "-31 $\frac{1}{4}$ "	32 $\frac{3}{4}$ "-32 $\frac{1}{2}$ "
Tire Size, Steer	16 $\frac{1}{2}$ " x 4" x 11 $\frac{1}{4}$ "	16 $\frac{1}{2}$ " x 4" x 11 $\frac{1}{4}$ "	16 $\frac{1}{2}$ " x 5" x 11 $\frac{1}{4}$ "	16 $\frac{1}{2}$ " x 5" x 11 $\frac{1}{4}$ "	16 $\frac{1}{2}$ " x 5" x 11 $\frac{1}{4}$ "	16 $\frac{1}{2}$ " x 6" x 11 $\frac{1}{4}$ "
Tire Size, Drive	17 $\frac{1}{2}$ " x 5" x 12 $\frac{1}{4}$ "	18" x 6" x 12 $\frac{1}{4}$ "	18" x 7" x 12 $\frac{1}{4}$ "	18" x 7" x 12 $\frac{1}{4}$ "	18" x 7" x 12 $\frac{1}{4}$ "	18" x 8" x 12 $\frac{1}{4}$ "
Underclearance, Center of Truck	5 $\frac{1}{2}$ "	5 $\frac{1}{2}$ "	5 $\frac{1}{2}$ "	5 $\frac{1}{2}$ "	5 $\frac{1}{2}$ "	5 $\frac{1}{2}$ "
Engine, Continental Model	Y-112	Y-112	F-163	F-163	F-163	F-163
Optional Power Types Available	LP-Gas	LP-Gas	LP-Gas	LP-Gas	LP-Gas Diesel	LP-Gas Diesel

Model 510P

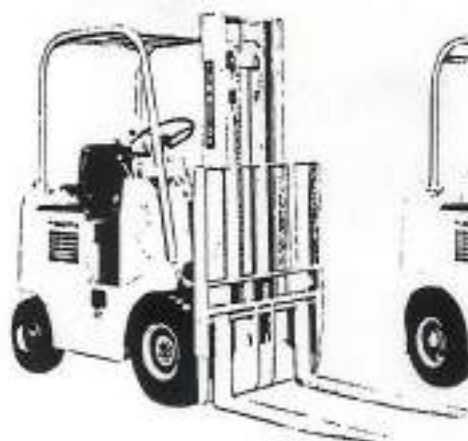

Model 502P

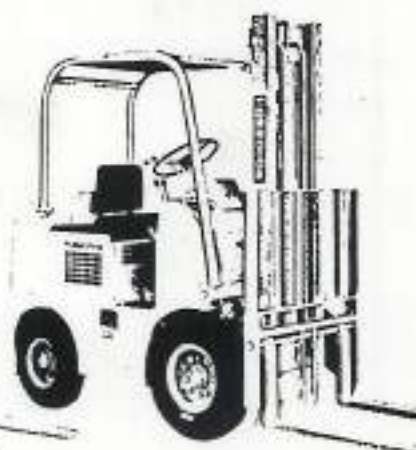

Model 601P

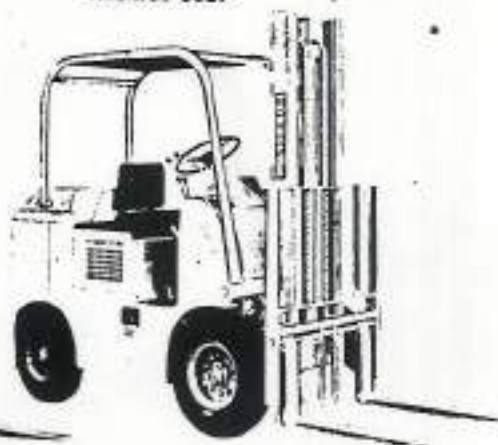

MODEL	510PG2024	510PG2524	502PG3024	502PG4024	601PG4024	601PG5024
Capacity, lbs.	2000	2500	3000	4000	4000	5000
Load Center	24"	24"	24"	24"	24"	24"
Inch-Pound Rating	77,750	97,500	121,500	163,000	163,000	203,750
Centerline of Drive Axle to Fork Face	14 1/2"	15"	15 1/2"	16 1/2"	16 1/2"	16 1/2"
Maximum Lift Height with Rated Load (1)	146"	144"	144"	144"	144"	144"
Maximum Fork Height	146"	146"	145 1/2"	146"	146"	146"
Mast Lowered Height	90 1/2"	90 1/2"	92"	92"	92"	92"
Mast Extended Height (Less Load Backrest With Load Backrest)	164 1/2" 194"	164 1/2" 194"	164 1/2" 194"	164 1/2" 194"	164 1/2" 194"	164 1/2" 194"
Free Lift	18"	17 1/2"	17"	17 1/2"	17 1/2"	17 1/2"
Truck Weight, lbs.	4630	5505	6330	7330	7205	7885
Tilt—Degrees (Forward Backward)	6 10	6 10	5 10	5 10	5 10	5 10
Speed of Lift, Loaded	120 fpm	90 fpm	80 fpm	80 fpm	80 fpm	80 fpm
Speed of Travel	Up to 11.5 mph	Up to 11.5 mph	Up to 10.0 mph	Up to 10.0 mph	Up to 10.0 mph	Up to 10.0 mph
Carriage Width	35"	37"	41"	41"	41"	41"
Carriage Height (Less Load Backrest With Load Backrest)	20 1/2" 50"	20 1/2" 50"	20 1/2" 50"	20 1/2" 50"	20 1/2" 50"	20 1/2" 50"
Forks, Standard Section and Length	1 1/2" x 4" x 30"	1 1/2" x 4" x 30"	1 1/2" x 4" x 36"	1 1/2" x 4" x 36"	1 1/2" x 4" x 36"	1 1/2" x 4" x 36"
Lateral Adjustment, In to In	1 1/2"	6 1/2"	6 1/2"	6 1/2"	6 1/2"	6 1/2"
Lateral Adjustment, Out to Out	33 1/2"	34 1/2"	38 1/2"	38 1/2"	38 1/2"	38 1/2"
Turning Radius (Outside Inside)	68" 2"	68" 2"	77 1/2" 3 1/2"	77 1/2" 3 1/2"	87 1/2" 6 1/2"	88 1/2" 0"
Minimum Intersecting Aisle	62 1/2"	62 1/2"	70 1/2"	72 1/2"	77"	81 1/2"
Minimum Aisle for Right Angle Stacking Less Load Length	82 1/2"	83"	94"	94"	104 1/2"	105"
Overall Width	37 1/2"	37 1/2"	41 1/2"	45 1/2"	45 1/2"	58 1/2"
Wheelbase	51"	51"	50"	50"	60"	60"
Overall Length, Less Forks and Towing Eye	78 1/2"	79"	85 1/2"	85 1/2"	95 1/2"	95 1/2"
Driver's Overhead Guard Height	83 1/2"	83 1/2"	86 1/2"	86 1/2"	86 1/2"	86 1/2"
Effective Seat Height	42 1/2"	42 1/2"	44 1/2"	44 1/2"	44 1/2"	44 1/2"
Tread, Steer—Drive	31"–30"	31"–30"	34 1/2"–34 1/2"	34 1/2"–38 1/2"	34 1/2"–38 1/2"	34 1/2"–42 1/2"
Tire Size, Steer	5.00" x 8" 8 Ply	5.00" x 8" 8 Ply	6.50" x 10" 10 Ply	6.50" x 10" 10 Ply	6.50" x 10" 10 Ply	6.50" x 10" 10 Ply
Tire Size, Drive	6.50" x 10" 10 Ply	6.50" x 10" 10 Ply	7.00" x 12" 12 Ply	7.00" x 12" 12 Ply	7.00" x 12" 12 Ply	7.00" x 12" 8 Ply Dual
Underclearance, Center of Truck	7 1/2"	7 1/2"	9 1/2"	9 1/2"	9 1/2"	9 1/2"
Engine, Continental Model	F-103	F-103	F-103	F-103	F-103	F-103
Optional Power Types Available	LP-Gas	LP-Gas	LP-Gas Diesel	LP-Gas Diesel	LP-Gas Diesel	LP-Gas Diesel

Model 950S

Model 750S

Model 850S

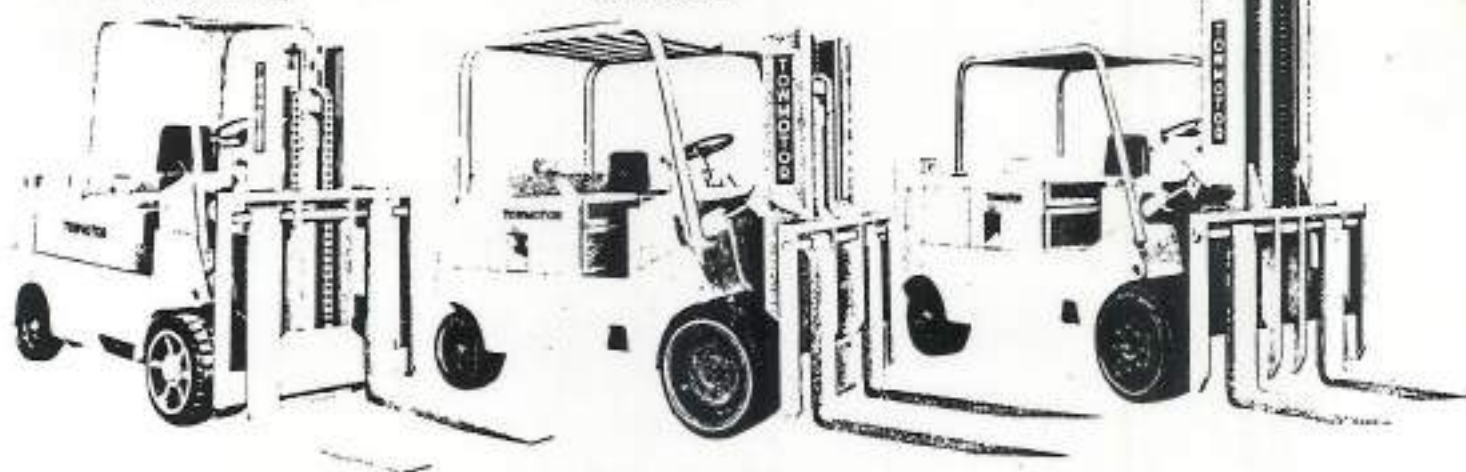

MODEL	750SG15024	850SG15024	850SG18024	850SG20024	950SG20030	950SG22030	950SG25030
Capacity, lbs.	15,000	15,000	18,000	20,000	20,000	22,000	25,000
Load Center	24"	24"	24"	24"	30"	30"	30"
Inch-Pound Rating	628,125	693,750	841,500	935,000	1,032,500	1,135,750	1,290,625
Centerline of Drive Axle to Fork Face	17 $\frac{3}{4}$ "	22 $\frac{1}{4}$ "	22 $\frac{3}{4}$ "	22 $\frac{3}{4}$ "	21 $\frac{3}{4}$ "	21 $\frac{3}{4}$ "	21 $\frac{3}{4}$ "
Maximum Lift Height with Rated Load(1)	144"	144"	144"	144"	144"	144"	144"
Maximum Fork Height	146 $\frac{1}{4}$ "	146 $\frac{1}{4}$ "	149 $\frac{3}{4}$ "	148 $\frac{3}{4}$ "	147 $\frac{1}{4}$ "	147 $\frac{1}{4}$ "	147 $\frac{1}{4}$ "
Most Lowered Height	111"	111"	111"	111"	126"	126"	126"
Most Extended Height	189 $\frac{1}{4}$ "	192 $\frac{3}{4}$ "	192 $\frac{3}{4}$ "	192 $\frac{3}{4}$ "	200 $\frac{1}{4}$ "	200 $\frac{1}{4}$ "	200 $\frac{1}{4}$ "
Free Lift	22 $\frac{3}{4}$ "	22 $\frac{3}{4}$ "	22 $\frac{3}{4}$ "	22 $\frac{3}{4}$ "	None	None	None
Truck Weight, lbs.	19,300	21,540	23,630	25,165	26,935	28,375	30,585
Tilt—Degrees	Forward Backward	5 10	5 10	5 10	5 10	5 10	5 10
Speed of Lift, Loaded	35 fpm	50 fpm	50 fpm	50 fpm	50 fpm	50 fpm	50 fpm
Speed of Travel	Up to 6.5 mph	Up to 6.5 mph	Up to 6.5 mph	Up to 6.5 mph	Up to 7.5 mph	Up to 7.5 mph	Up to 7.5 mph
Carriage Width	54"	54"	54"	54"	62"	62"	62"
Carriage Height	45 $\frac{1}{4}$ "	48 $\frac{3}{4}$ "	48 $\frac{3}{4}$ "	48 $\frac{3}{4}$ "	56 $\frac{1}{4}$ "	56 $\frac{1}{4}$ "	56 $\frac{1}{4}$ "
Forks, Standard Section and Length	2 $\frac{1}{2}$ " x 7" x 42"	2 $\frac{1}{2}$ " x 7" x 42"	2 $\frac{3}{4}$ " x 7" x 42"	2 $\frac{3}{4}$ " x 7" x 42"	3 $\frac{1}{2}$ " x 8" x 48"	3 $\frac{1}{2}$ " x 8" x 48"	3 $\frac{1}{2}$ " x 8" x 48"
Lateral Adjustment, In to In	17"	16"	16"	16"	19 $\frac{1}{2}$ "	19 $\frac{1}{2}$ "	19 $\frac{1}{2}$ "
Lateral Adjustment, Out to Out	50 $\frac{1}{4}$ "	50 $\frac{1}{4}$ "	50 $\frac{1}{4}$ "	50 $\frac{1}{4}$ "	57 $\frac{3}{4}$ "	57 $\frac{3}{4}$ "	57 $\frac{3}{4}$ "
Turning Radius	Outside Inside	110 $\frac{3}{4}$ " 6 $\frac{1}{2}$ "	112 $\frac{3}{4}$ " 4 $\frac{1}{2}$ "	112 $\frac{3}{4}$ " 2 $\frac{1}{2}$ "	128" 4 $\frac{5}{8}$ "	128" $\frac{1}{2}$ "	128" $\frac{1}{2}$ "
Minimum Intersecting Aisle	93 $\frac{1}{2}$ "	96"	97 $\frac{1}{2}$ "	97 $\frac{1}{2}$ "	109 $\frac{1}{4}$ "	112"	112"
Minimum Aisle for Right Angle Stacking Less Load Length	128 $\frac{1}{4}$ "	134 $\frac{3}{4}$ "	135 $\frac{1}{4}$ "	135 $\frac{1}{4}$ "	149 $\frac{1}{4}$ "	149 $\frac{1}{4}$ "	149 $\frac{1}{4}$ "
Overall Width	58 $\frac{1}{2}$ "	54"	58"	58"	62"	70"	70"
Wheelbase	75"	85"	85"	85"	95"	95"	95"
Overall Length, Less Forks and Towing Eye	117 $\frac{3}{4}$ "	127"	127"	127"	141 $\frac{3}{4}$ "	141 $\frac{3}{4}$ "	141 $\frac{3}{4}$ "
Driver's Overhead Guard Height	88"	94 $\frac{1}{2}$ "	94 $\frac{1}{2}$ "	94 $\frac{1}{2}$ "	94 $\frac{1}{2}$ "	94 $\frac{1}{2}$ "	94 $\frac{1}{2}$ "
Effective Seat Height	47 $\frac{1}{4}$ "	50 $\frac{1}{2}$ "	50 $\frac{1}{2}$ "	50 $\frac{1}{2}$ "	50 $\frac{3}{4}$ "	50 $\frac{3}{4}$ "	50 $\frac{3}{4}$ "
Tread, Steer—Drive	38"-42 $\frac{1}{2}$ "	46"-40"	46"-42"	44"-42"	51"-48"	51"-50"	51"-50"
Tire Size, Steer	18" x 8" x 12 $\frac{1}{2}$ "	22" x 7" x 16"	22" x 8" x 16"	22" x 9" x 16"	22" x 10" x 16" Solid	22" x 10" x 16" Solid	22" x 10" x 16" Solid
Tire Size, Drive	22" x 8" x 16" Dual	28" x 7" x 22" Solid Dual	28" x 16" x 22" Solid	28" x 16" x 22" Solid	28" x 16" x 22" Solid	28" x 10" x 22" Solid Dual	28" x 10" x 22" Solid Dual
Underclearance, Center of Truck	8"	6 $\frac{1}{2}$ "	6 $\frac{1}{2}$ "	6 $\frac{1}{2}$ "	8 $\frac{1}{2}$ "	8 $\frac{1}{2}$ "	8 $\frac{1}{2}$ "
Engine	*F-245	1V-266	1V-266	1V-266	1V-304	1V-304	1V-304
Optional Power Types Available	LP-Gas	LP-Gas Diesel	LP-Gas Diesel	LP-Gas Diesel	LP-Gas	LP-Gas	LP-Gas

MODEL L501-P

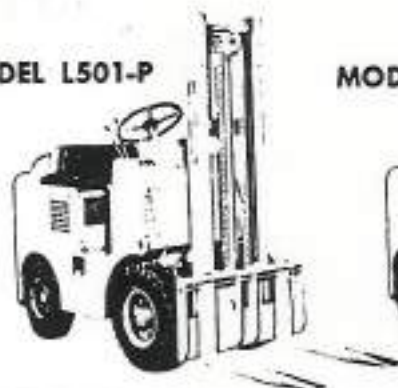

MODEL 501-P

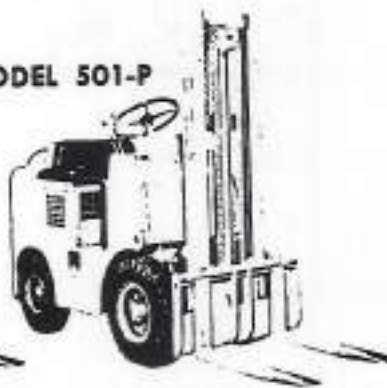

MODEL 680-P

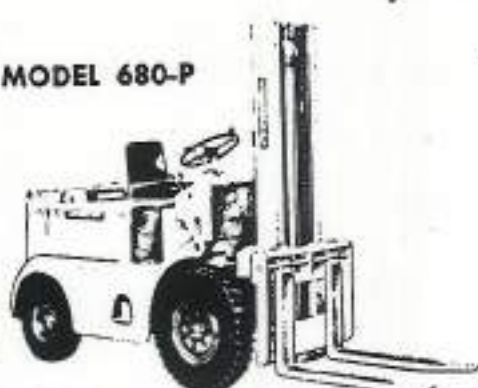

MODEL	L501-P	L501-PLP	L501-PD	501-P	501-PLP	501-PD	680-P	680-PLP	680-PD					
Capacity, lbs.—inch lbs.	3,000—127,500			4,000—171,000			(A) 36,000—273,500 (B) 71,000—317,625	8,000—363,000						
Load Center	94"			94"			94"		94"					
Lift Height	72"	108"	120"	144"	72"	108"	120"	144"	84"	120"	144"	84"	120"	144"
Maximum Fork Height	73 1/2"	109 1/2"	121 1/2"	145 1/2"	73 1/2"	109 1/2"	121 1/2"	145 1/2"	86 1/2"	122 1/2"	146 1/2"	86 1/2"	122 1/2"	146 1/2"
Mast Height Lowered	67"	85"	85"	103"	67"	85"	85"	103"	68"	86"	98"	74"	95"	104"
Mast Height Extended	92 1/4"	128 1/4"	140 1/4"	164 1/4"	92 1/4"	128 1/4"	140 1/4"	164 1/4"	109 1/4"	145 1/4"	169 1/4"	116 3/8"	153 3/8"	176 3/8"
Free Lift	25 1/2"	25 1/2"	13 1/2"	25 1/2"	25 1/2"	25 1/2"	17 1/2"	17 1/2"	17 1/2"	26 1/2"	26 1/2"	26 1/2"	26 1/2"	26 1/2"
*Weight, lbs.	Gasoline: 6145 6205 6310 6555 LP-Gas: 6195 6235 6360 6605 Diesel: 6160 6500 6555 6770			Gasoline: 6785 6925 6950 7235 LP-Gas: 6835 6975 7000 7285 Diesel: 7000 7140 7165 7450			Gasoline: (A) 9315 9800 9990 (B) 10465 10150 10940		Gasoline: 11610 11895 12085					
Tilt	3°-5° Fwd., 10° Bkwd.			3°-5° Fwd., 10° Bkwd.			3°-5° Fwd., 10° Bkwd.		3°-5° Fwd., 10° Bkwd.					
Length, Less Forks	84 1/2"			88 1/2"			110 3/4"		110 3/4"					
Width, Overall	41 1/2"			41 1/2"			53 3/4"		53 3/4"					
Wheelbase	50"			50"			68"		68"					
Underclearance	9 1/2" (Diesel: 8")			9 1/2" (Diesel: 8")			10 1/2"		10 3/4"					
Carriage Rollers, No.	4			4			4		4					
Carriage Width	41"			41"			44"		44"					
Carriage Ht. Above Floor	20 1/4"			20 1/4"			25 1/2"		35 3/4"					
Turning Radius, Outside	85 1/2"			87"			110"		110"					
Turning Radius, Inside	18"			18"			20"		20"					
Turns in Intersecting Aisles	70 1/2"			73 1/2"			89 1/4"		89 3/4"					
Min. Aisle Right Angle Stacking	140"			141 3/4"			173 1/2"		173 3/4"					
Speed of Travel	up to 10 mph			up to 10 mph			up to 11.5 mph		up to 11.5 mph					
Speed of Lift, Loaded	50 F.P.M.			50 F.P.M.			(A) 50 F.P.M. (B) 45 F.P.M.		50 F.P.M.					
Forks, Standard Length	36"			36"			42"		45"					
Lateral Adj., In-In	6 1/2"			6 1/2"			1 1/2"		1 1/4"					
Lateral Adj., Out-Out	39"			39"			41 1/2"		41 1/2"					
Tread, Steer-Drive	35 1/2"—34"			39 3/4"—34"			45 1/2"—43"		45 1/2"—43"					
Tires, Steer	6.50" x 10" Pneumatic			6.50" x 10" Pneumatic			7.50" x 10" Pneumatic		7.50" x 10" Pneumatic					
Tires, Drive	7.00" x 12" Pneumatic			7.00" x 12" Pneumatic			8.25" x 15" Pneumatic		8.25" x 15" Pneumatic					
Drive Axle to Fork Face	18 1/2"			18 1/4"			21 1/2"		21 3/4"					
Seat Height Above Floor	46 1/4"			46 1/4"			52 1/4"		52 3/4"					
Ht. of Truck Exclusive of Mast	64 1/2"			64 1/2"			69"		69"					
Gasoline & LPG Engine—Caterpillar Diesel Engine—Cummins	F-102 GD-157			F-102 GD-157			F-209 HD-260		F-226 HD-260					

Model 860P

Model 760P

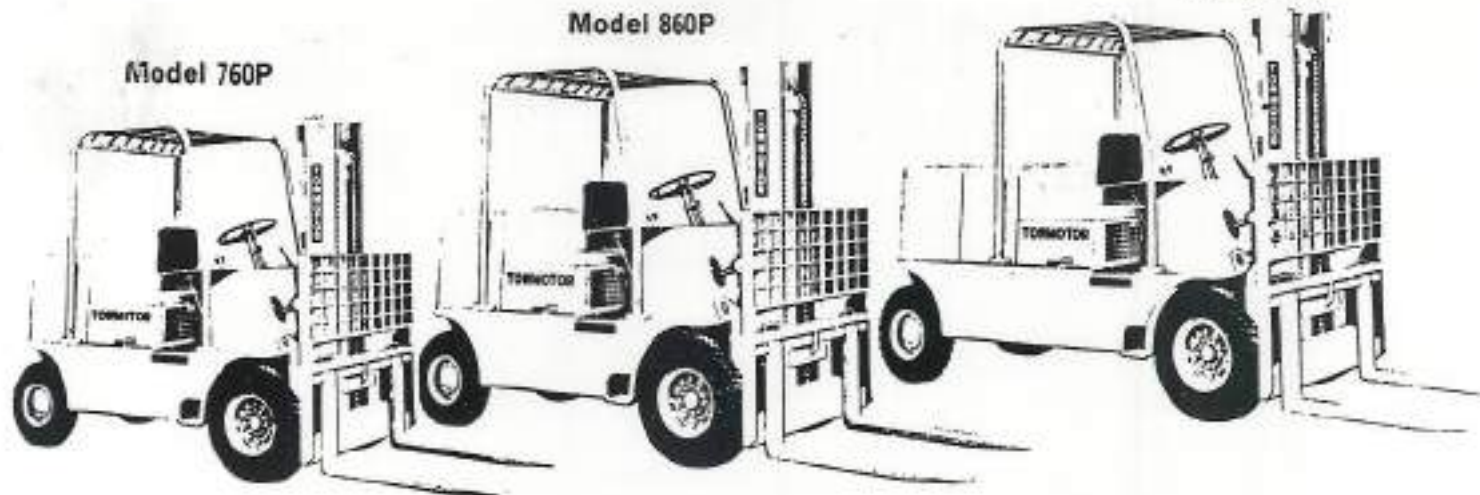

MODEL	760PG6024	760PG7024	860PG8024	860PG9024	960PG10024
Capacity, lbs.	6000	7000	8000	9000	10,000
Load Center	24"	24"	24"	24"	24"
Inch-Pound Rating	248,250	289,625	331,000	374,625	416,250
Centerline of Drive Axle to Fork Face	17 $\frac{1}{2}$ "	17 $\frac{1}{2}$ "	17 $\frac{1}{2}$ "	17 $\frac{1}{2}$ "	17 $\frac{1}{2}$ "
Maximum Lift Height with Rated Load (1)	144"	144"	144"	144"	144"
Maximum Fork Height	146 $\frac{1}{2}$ "	146 $\frac{1}{2}$ "	146 $\frac{1}{2}$ "	146 $\frac{1}{2}$ "	146 $\frac{1}{2}$ "
Maxi Lowered Height	58"	58"	104"	104"	109"
Maxi Extended Height	169 $\frac{1}{2}$ " 194 $\frac{1}{2}$ "	169 $\frac{1}{2}$ " 194 $\frac{1}{2}$ "	176 $\frac{1}{2}$ " 194 $\frac{1}{2}$ "	176 $\frac{1}{2}$ " 194 $\frac{1}{2}$ "	178 $\frac{1}{2}$ " 194 $\frac{1}{2}$ "
Free Lift	17 $\frac{1}{4}$ "	17 $\frac{1}{4}$ "	26 $\frac{1}{4}$ "	26 $\frac{1}{4}$ "	35 $\frac{1}{4}$ "
Truck Weight, lbs.	9525	10,405	11,125	11,795	11,800
Tilt—Degrees	6 12	6 12	6 12	6 12	6 12
Speed of Lift, Loaded	75 fpm	75 fpm	60 fpm	60 fpm *	55 fpm
Speed of Travel	Up to 17.0 mph	Up to 17.0 mph	Up to 17.0 mph	Up to 17.0 mph	Up to 17.0 mph
Carriage Width	54"	54"	54"	54"	54"
Carriage Height	23 $\frac{1}{2}$ " 50 $\frac{1}{2}$ "	23 $\frac{1}{2}$ " 50 $\frac{1}{2}$ "	32 $\frac{1}{2}$ " 50 $\frac{1}{2}$ "	32 $\frac{1}{2}$ " 50 $\frac{1}{2}$ "	34 $\frac{1}{2}$ " 50 $\frac{1}{2}$ "
Forks, Standard Section and Length	1 $\frac{3}{4}$ " x 5" x 42"	1 $\frac{3}{4}$ " x 5" x 42"	2" x 5" x 42"	2" x 5" x 42"	2" x 6" x 42"
Lateral Adjustment, In to In	1 $\frac{1}{4}$ "	1 $\frac{1}{4}$ "	1 $\frac{1}{4}$ "	1 $\frac{1}{4}$ "	1 $\frac{1}{4}$ "
Lateral Adjustment, Out to Out	51 $\frac{1}{2}$ "	51 $\frac{1}{2}$ "	51 $\frac{1}{2}$ "	51 $\frac{1}{2}$ "	51 $\frac{1}{2}$ "
Turning Radius	99 $\frac{1}{2}$ " 8 $\frac{1}{2}$ "	99 $\frac{1}{2}$ " 8 $\frac{1}{2}$ "	110 $\frac{1}{2}$ " 13"	110 $\frac{1}{2}$ " 13"	122 $\frac{1}{4}$ " 18"
Minimum Intersecting Aisle	88 $\frac{1}{4}$ "	88 $\frac{1}{4}$ "	93 $\frac{1}{4}$ "	93 $\frac{1}{4}$ "	96 $\frac{1}{2}$ "
Minimum Aisle for Right Angle Stacking Less Load Length	116 $\frac{1}{2}$ "	116 $\frac{1}{2}$ "	128 $\frac{1}{4}$ "	128 $\frac{1}{4}$ "	139 $\frac{1}{2}$ "
Overall Width	55"	55"	55"	55"	55"
Wheelbase	76"	76"	86"	86"	96"
Overall Length, Less Forks and Towing Eye	105"	109"	119"	119"	129 $\frac{1}{4}$ "
Driver's Overhead Guard Height	85 $\frac{1}{16}$ "	86 $\frac{1}{16}$ "	85 $\frac{1}{16}$ "	85 $\frac{1}{16}$ "	85 $\frac{1}{16}$ "
Effective Seat Height	45"	45"	45"	45"	45"
Trail, Steer—Drive	39 $\frac{1}{16}$ "-38 $\frac{1}{16}$ "	39 $\frac{1}{16}$ "-38 $\frac{1}{16}$ "	39 $\frac{1}{16}$ "-38 $\frac{1}{16}$ "	39 $\frac{1}{16}$ "-38 $\frac{1}{16}$ "	39 $\frac{1}{16}$ "-38 $\frac{1}{16}$ "
Tire Size, Steer	6.50" x 10" 9 Ply	6.50" x 10" 10 Ply	6.50" x 10" 10 Ply	7.50" x 10" 10 Ply	7.50" x 10" 10 Ply
Tire Size, Drive	7.00" x 12" 8 Ply Dual	7.00" x 12" 12 Ply Dual	7.00" x 12" 12 Ply Dual	7.00" x 12" 12 Ply Dual	7.00" x 12" 12 Ply Dual
Underclearance, Center of Truck	8"	8"	8"	8"	8 $\frac{1}{2}$ "
Engine, Continental Model	F-227	F-227	F-227	F-227	F-227
Optional Power Types Available	LP-Gas	LP-Gas	LP-Gas	LP-Gas	LP-Gas

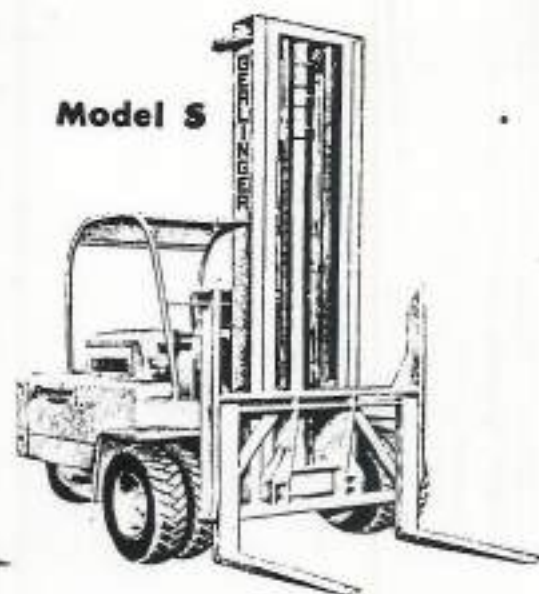
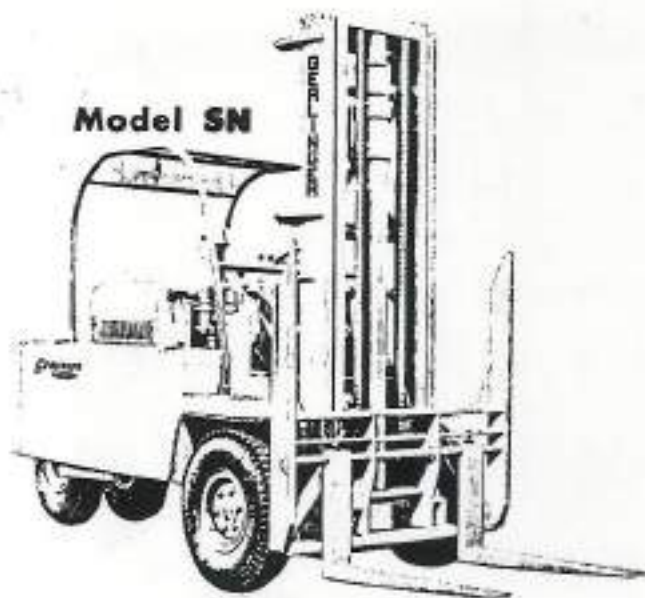

MODEL	S-10N	S-10	S-12	S-15	S-16	S-18
Capacity	10,000 lbs.	10,000 lbs.	12,000 lbs.	15,000 lbs.	16,000 lbs.	18,000 lbs.
Load Center	24"	24"	24"	25"	25"	24"
Inch-Pound Rating with 135% Safety Factor	480,000 in.-lbs.	480,000 in.-lbs.	576,000 in.-lbs.	735,000 in.-lbs.	800,000 in.-lbs.	882,000 in.-lbs.
Inch-Pound Rating BALANCED	700,000 in.-lbs.	700,000 in.-lbs.	790,000 in.-lbs.	985,000 in.-lbs.	1,080,000 in.-lbs.	1,170,000 in.-lbs.
Height Mast Lowered	8' 8"	8' 7"	9' 4 1/2"	9' 4 1/2"	9' 5 1/2"	9' 6"
Height Mast Extended	16' 1 3/4"	16' 1 3/4"	16' 1 3/4"	16' 1 3/4"	16' 1 3/4"	16' 1 3/4"
Height of Lift	10' 0"	10' 0"	10' 0"	10' 0"	10' 0"	10' 0"
Speed of Lift Limited	28 fpm	38 fpm	32 fpm	30 fpm	30 fpm	24 fpm
Speed of Lift Empty	48 fpm	48 fpm	48 fpm	42 fpm	42 fpm	38 fpm
Speed of Travel	up to 16 mph	up to 14 mph	up to 15 mph	up to 15 mph	up to 15 mph	up to 16 mph
Fork Spacing Inside to Outside	22" to 66"	22" to 66"	20" to 66"	20" to 66"	20" to 66"	20" to 66"
Fork Length	48"	48"	48"	48"	48"	48"
Fork Section	2 1/2" x 6"	2 1/2" x 6"	2 1/2" x 6"	2 1/2" x 6"	2 1/2" x 6"	3" x 7"
Tilt Forward	6°	6°	6°	6°	6°	6°
Tilt Backward	0°	0°	0°	0°	0°	0°
Overall Width	70 1/2"	69 1/2"	93"	93"	91"	94 1/2"
Wheelbase	106"	106"	106"	106"	115"	115"
Overall Length Less Forks	150"	150"	151"	154"	164"	166"
Overall Length With Forks	198"	198"	199"	202"	212"	214"
Turning Radius	21"	10"	10"	10"	10"	10"
Tail Swing	138"	138"	130"	145"	150"	159"
Min. Width of Intersecting Aisle for 90° Turn	117"	117"	118"	121"	129"	131"
Underclearance Axle	13"	11 1/2"	12 1/2"	12 1/2"	13 1/2"	13"
Underclearance Mast	12"	11"	10 1/2"	10 1/2"	10 3/4"	11"
Tires	9:00 x 15	7:50 x 15	8:25 x 15	8:25 x 15	8:25 x 15	9:00 x 15
Total Weight	15,700 lbs.	16,000 lbs.	17,050 lbs.	19,500 lbs.	19,000 lbs.	20,900 lbs.
Weight on Drive Wheels	9,100 lbs.	9,100 lbs.	10,000 lbs.	10,200 lbs.	10,800 lbs.	10,500 lbs.
Weight on Steer Wheels	6,600 lbs.	6,900 lbs.	7,050 lbs.	9,300 lbs.	8,200 lbs.	10,400 lbs.
Ram Size	6 1/2"	6 1/2"	6 1/2"	6 1/2"	6 1/2"	7"
Axle C/L to Face of Garrage	24"	24"	24"	24"	25"	25"
Wheel Brakes † Vacuum Booster on Models S, G, & W	16 1/2" x 4"	16 1/2" x 4"	16 1/2" x 4"	16 1/2" x 4"	16 1/2" x 4"	16 1/2" x 4"
Engine	A	A	A	A	B	B

A STANDARD—Continental Model F-244, 6 cyl.
OPTIONAL—Ford V-8 Ind., Model J, OHV
(At Extra Cost)—Hercules GO 298, 6 cyl.
Hercules Diesel DD 298, 6 cyl.—85 H.P.

B STANDARD—Continental Model M-330, 6 cyl.
OPTIONAL—Ford V-8 Ind., Model J, OHV
Hercules GO 298, 6 cyl.
(At Extra Cost)—Hercules Diesel DD 298, 6 cyl.—85 H.P.

C STANDARD—Ford V-8 Ind., Model J, OHV
OPTIONAL—Hercules GO 298, 6 cyl.
(At Extra Cost)—Hercules Diesel DD 298, 6 cyl.—85 H.P.

D STANDARD—Continental Model M-363, 6 cyl.
OPTIONAL—Ford V-8 Ind., Model L, OHV
Hercules GO 339, 6 cyl.
(At Extra Cost)—Hercules Diesel DD 339, 6 cyl.—100 H.P.

E STANDARD—Continental Model T-6427, 6 cyl.
(At Extra Cost)—Continental Diesel, 6 cyl.—147 H.P.

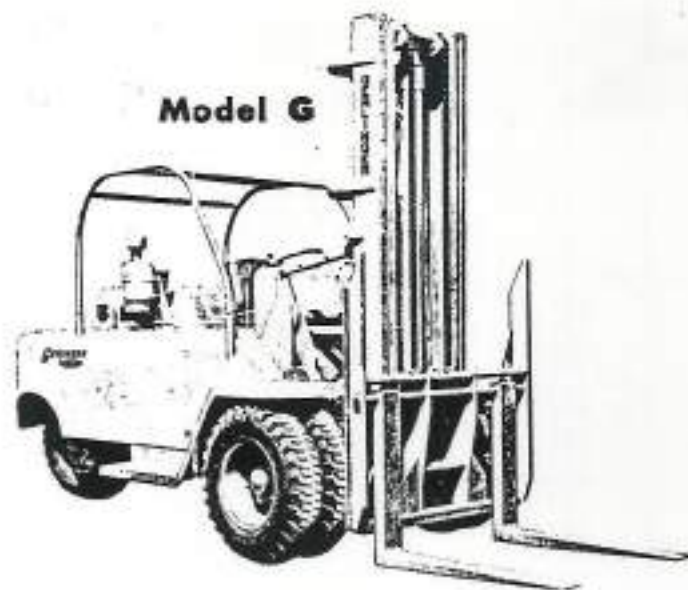

Model G

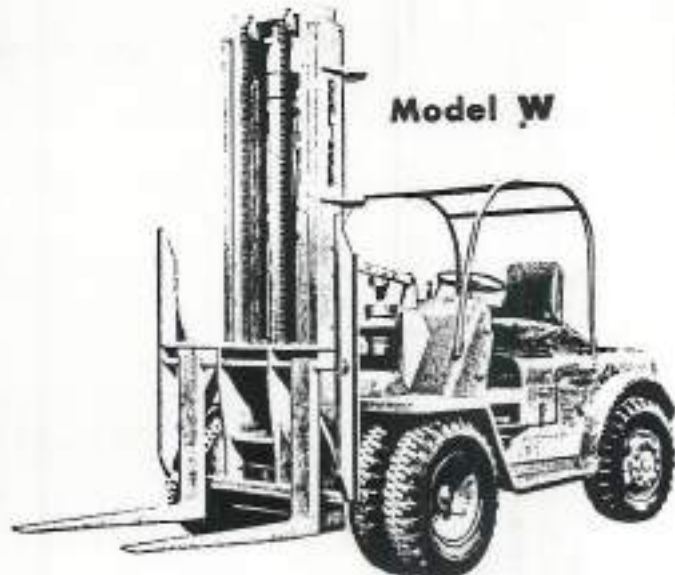

Model W

MODEL	G-20	G-22	W-12	W-15	W-16	W-18	W-20	W-22
Capacity	20,000 lbs.	22,000 lbs.	12,000 lbs.	13,000 lbs.	16,000 lbs.	18,000 lbs.	20,000 lbs.	22,000 lbs.
Load Center	24"	24"	21"	24"	27"	27"	24"	24"
Inch-Pound Rating with 135% Safety Factor	1,100,000 in.-lbs.	1,210,000 in.-lbs.	648,000 in.-lbs.	765,000 in.-lbs.	990,000 in.-lbs.	1,044,000 in.-lbs.	1,100,000 in.-lbs.	1,210,000 in.-lbs.
Inch-Pound Rating BALANCED	1,485,000 in.-lbs.	1,635,000 in.-lbs.	876,000 in.-lbs.	1,032,000 in.-lbs.	1,340,000 in.-lbs.	1,410,000 in.-lbs.	1,485,000 in.-lbs.	1,635,000 in.-lbs.
Height Mast Lowered	9' 5 1/4"	9' 5 1/4"	9' 6 1/2"	9' 6 1/2"	9' 5 1/4"	9' 5 1/4"	9' 5 1/4"	9' 5 1/4"
Height Mast Extended	16' 1 1/4"	16' 1 1/4"	16' 1 3/4"	16' 1 3/4"	16' 1 3/4"	16' 1 3/4"	16' 1 3/4"	16' 1 1/4"
Height of Lift	10' 0"	10' 0"	10' 0"	10' 0"	10' 0"	10' 0"	10' 0"	10' 0"
Speed of Lift Loaded	40 fpm	40 fpm	60 fpm	60 fpm	60 fpm	60 fpm	49 fpm	49 fpm
Speed of Lift Empty	43 fpm	43 fpm	69 fpm	69 fpm	69 fpm	60 fpm	49 fpm	49 fpm
Speed of Travel	up to 15 mph	up to 15 mph	up to 17 mph	up to 17 mph	up to 15 mph	up to 15 mph	up to 15 mph	up to 15 mph
Fork Spacing Inside to Outside	20" to 66"	20" to 66"	20" to 66"	20" to 66"	20" to 66"	20" to 96"	20" to 66"	20" to 66"
Fork Length	48"	48"	48"	48"	48"	48"	48"	48"
Fork Section	3" x 1"	3" x 1"	2 1/2" x 6"	2 1/2" x 6"	2 1/2" x 6"	3" x 1"	3" x 1"	3" x 1"
Tilt Forward	7"	7"	7"	7"	7"	7"	7"	7"
Tilt Backward	8"	8"	8"	8"	8"	8"	8"	8"
Overall Width	94"	94"	93 1/4"	93 1/4"	94"	94"	94"	94"
Wheelbase	136"	136"	106"	106"	106"	125"	125"	125"
Overall Length Less Forks	201"	203"	132"	132"	176"	195"	195"	195"
Overall Length With Forks	249"	251"	220"	220"	224"	243"	243"	243"
Turning Radius	24"	24"	28"	28"	28"	42"	42"	42"
Tail Swing	175"	177"	169"	169"	169"	185"	185"	185"
Min. Width of Intersecting Aisle for 90° Turn	144"	146"	141"	141"	141"	143"	143"	143"
Underclearance Axle	16 1/2"	16 1/2"	15 3/4"	15 3/4"	16 1/2"	16 1/2"	16 1/2"	16 1/2"
Underclearance Mast	10 1/4"	10 1/4"	12"	12"	10 1/4"	10 1/4"	10 1/4"	10 1/4"
Tires	9-00 x 20	9-00 x 20	8-95 x 20	8-25 x 20	9-00 x 20	9-00 x 20	9-00 x 20	9-00 x 20
Total Weight	21,700 lbs.	22,700 lbs.	18,570 lbs.	20,050 lbs.	22,100 lbs.	22,400 lbs.	23,300 lbs.	24,400 lbs.
Weight on Drive Wheels	10,300 lbs.	10,100 lbs.	10,300 lbs.	10,300 lbs.	10,300 lbs.	11,200 lbs.	11,400 lbs.	11,300 lbs.
Weight on Steer Wheels	11,400 lbs.	12,600 lbs.	8,270 lbs.	9,750 lbs.	11,800 lbs.	11,200 lbs.	11,900 lbs.	13,100 lbs.
Ram Size	7 1/2"	7 1/2"	6 1/2"	6 1/2"	6 1/2"	7"	7 1/2"	7 1/2"
Axle C/L to Face of Carriage	31"	31"	27"	27"	31"	31"	31"	31"
Wheel Brakes 1 Vacuum Booster on Models S, G, & W	16 1/2" x 4"	16 1/2" x 4"	16 1/2" x 4"	16 1/2" x 4"	16 1/2" x 4"	16 1/2" x 4"	16 1/2" x 4"	16 1/2" x 4"
Engine	C	C	A	A	B	B	B	B

A STANDARD—Continental Model F-344, 6 cyl.
OPTIONAL—Ford V-8 Ind., Model J, OHV
(At Extra Cost)—Hercules GO 298, 6 cyl.
Hercules Diesel DD 298, 6 cyl.—85 H.P.

B STANDARD—Continental Model M-130, 6 cyl.
OPTIONAL—Ford V-8 Ind., Model J, OHV
Hercules GO 298, 6 cyl.
(At Extra Cost)—Hercules Diesel DD 298, 6 cyl.—85 H.P.

C STANDARD—Ford V-8 Ind., Model J, OHV
OPTIONAL—Hercules GO 298, 6 cyl.
(At Extra Cost)—Hercules Diesel DD 298, 6 cyl.—85 H.P.

D STANDARD—Continental Model M-361, 6 cyl.
OPTIONAL—Ford V-8 Ind., Model L, OHV
Hercules GO 319, 6 cyl.
(At Extra Cost)—Hercules Diesel DD 339, 6 cyl.—100 H.P.

E STANDARD—Continental Model T-6421, 6 cyl.
(At Extra Cost)—Continental Diesel, 6 cyl.—147 H.P.

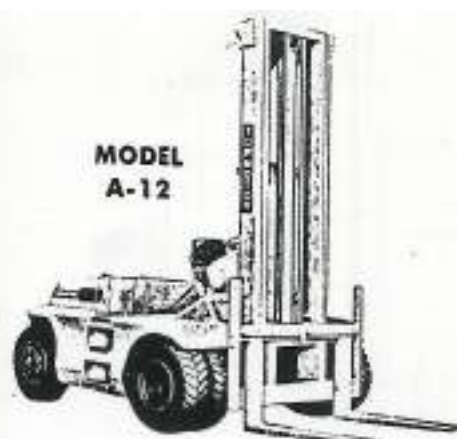
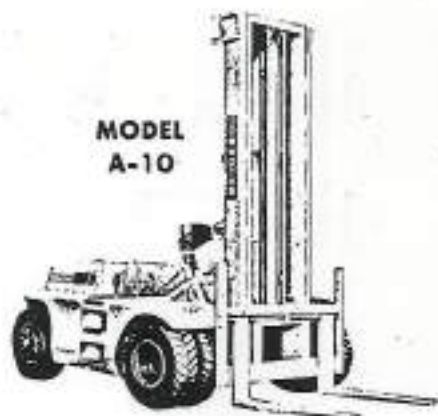

MODEL	A-10	A-12	A-15	A-16
Capacity	10,000 lbs. 470,000 in.-lbs.	12,000 lbs. 564,000 in.-lbs.	15,000 lbs. 754,000 in.-lbs.	16,500 lbs. 829,000 in.-lbs.
Load Center	24"	24"	24"	24"
Height of Mast Lowered	8' 2 1/4"	8' 3"	9' 2"	9' 2"
Height of Mast Extended	13' 2 1/4"	13' 3"	14' 1 3/4"	14' 1 3/4"
Height of Carriage Raised	14' 0"	14' 0"	15' 6"	15' 6"
Height of Lift	10' 0"	10' 0"	10' 0"	10' 0"
Speed of Lift Loaded	65 fpm	65 fpm	75 fpm	75 fpm
Speed of Lift Empty	80 fpm	80 fpm	105 fpm	105 fpm
Speed of Travel	20 mph	20 mph	23 mph	23 mph
Fork Spacing Inside to Outside	2" to 66"	2" to 66"	2" to 66"	2" to 66"
Fork Length	48"	48"	48"	48"
Fork Section	2" x 7"	2" x 7"	2 1/2" x 6"	2 1/2" x 6"
Tilt Forward	6°	6°	6°	6°
Tilt Backward	12°	12°	12°	12°
Overall Width	90"	90"	96"	96"
Wheelbase	86"	86"	106"	106"
Overall Length Less Forks	143"	143"	168"	168"
Overall Length With Forks	191"	191"	216"	216"
Inside Turning Radius	9"	9"	13"	13"
Outside Turning Radius	134"	134"	158"	158"
Min. Width of Intersecting Aisle for 90° Turn	125"	125"	145"	145"
Tires	7:50 x 15	8:25 x 15	9:00 x 20	9:00 x 20
Total Weight Empty	15,300 lbs.	16,730 lbs.	21,650 lbs.	22,550 lbs.
Empty Weight on Drive Wheels	8,200 lbs.	8,200 lbs.	12,400 lbs.	12,350 lbs.
Empty Weight on Steer Wheels	7,110 lbs.	8,530 lbs.	9,250 lbs.	10,200 lbs.
CL of Axle to Face of Fork	23"	23"	26 1/4"	26 1/4"
Wheel Brakes	12" x 2 1/2"	12" x 2 1/2"	16" x 6"	16" x 6"
ENGINE	Standard Diesel Std. Trans. Auto. Trans.	Continental F-244 Hercules DD226H	Continental F-244 Hercules DD226H	Continental M-330 Hercules D298H D339H

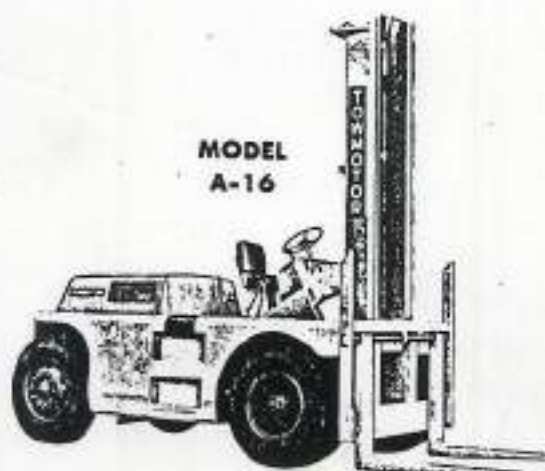
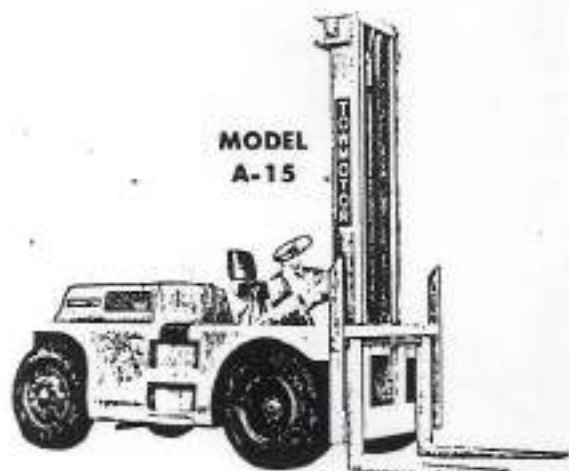

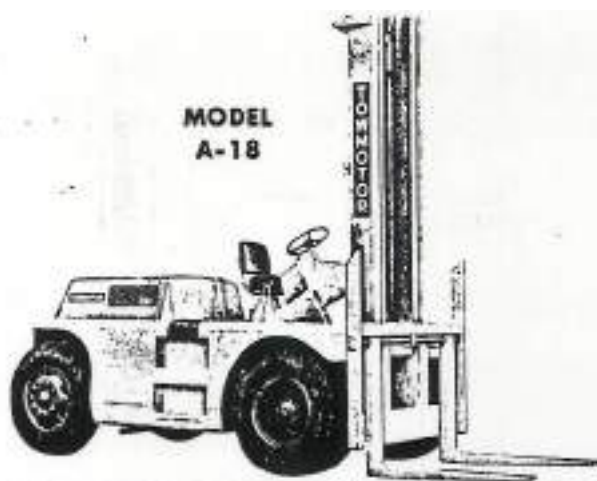

**MODEL
A-18**

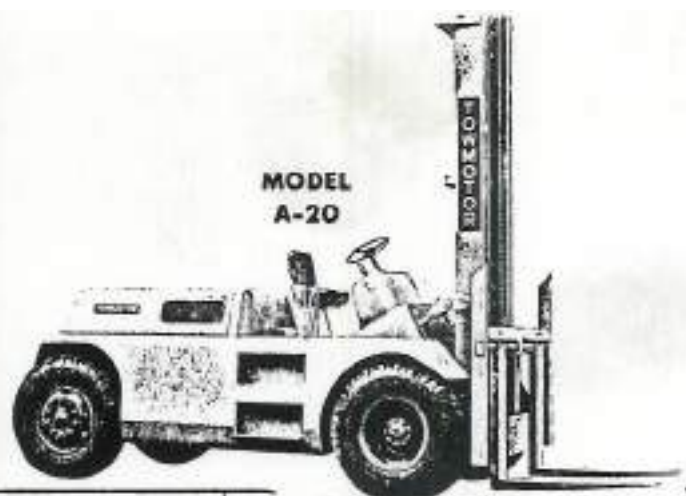

**MODEL
A-20**

MODEL	A-18	A-20	A-22	A-24
Capacity	18,000 lbs.	20,000 lbs.	22,000 lbs.	24,000 lbs.
	905,000 in.-lbs.	1,050,000 in.-lbs.	1,155,000 in.-lbs.	1,260,000 in.-lbs.
Load Center	24"	24"	24"	24"
Height of Mast Lowered	9' 2"	9' 3 3/4"	9' 3 3/4"	9' 3 3/4"
Height of Mast Extended	14' 1 3/4"	14' 3 1/2"	14' 3 1/2"	14' 3 1/2"
Height of Carriage Raised	15' 6"	15' 5 1/2"	15' 5 1/2"	15' 5 1/2"
Height of Lift	10' 0"	10' 0"	10' 0"	10' 0"
Speed of Lift Loaded	75 fpm	50 fpm	50 fpm	50 fpm
Speed of Lift Empty	105 fpm	75 fpm	75 fpm	75 fpm
Speed of Travel	23 mph	23 mph	23 mph	23 mph
Fork Spacing Inside to Outside	2" to 66"	2" to 66"	2" to 66"	2" to 66"
Fork Length	48"	48"	48"	48"
Fork Section	2 1/2" x 1"	3" x 7"	3" x 7"	3" x 7"
Tilt Forward	6°	6°	6°	6°
Tilt Backward	12°	12°	12°	12°
Overall Width	96"	96"	96"	96"
Wheelbase	105"	120"	120"	120"
Overall Length Less Forks	165"	184"	187"	187"
Overall Length With Forks	216"	232"	235"	235"
Inside Turning Radius	13'	16"	16"	16"
Outside Turning Radius	158"	171"	173"	173"
Min. Width of Intersecting Aisle for 90° Turn	145"	155"	157"	157"
Tires	9-00 x 20	10-00 x 20	10-00 x 20	10-00 x 20
Total Weight Empty	23,500 lbs.	24,650 lbs.	25,630 lbs.	26,680 lbs.
Empty Weight on Drive Wheels	12,400 lbs.	13,150 lbs.	13,000 lbs.	12,900 lbs.
Empty Weight on Steer Wheels	11,100 lbs.	11,500 lbs.	12,630 lbs.	13,780 lbs.
CL of Axle to Face of Fork	26 1/4"	28 1/2"	28 1/2"	28 1/2"
Wheel Brakes	16" x 6"	16" x 6"	16" x 6"	16" x 6"
Standard ENGINE	Continental M-330	Continental M-330	Continental M-330	Continental M-330
Diesel	Hercules	Hercules	Hercules	Hercules
Sid. Trans.	D298H	D298H	D298H	D298H
Auto. Trans.	D339H	D339H	D339H	D339H

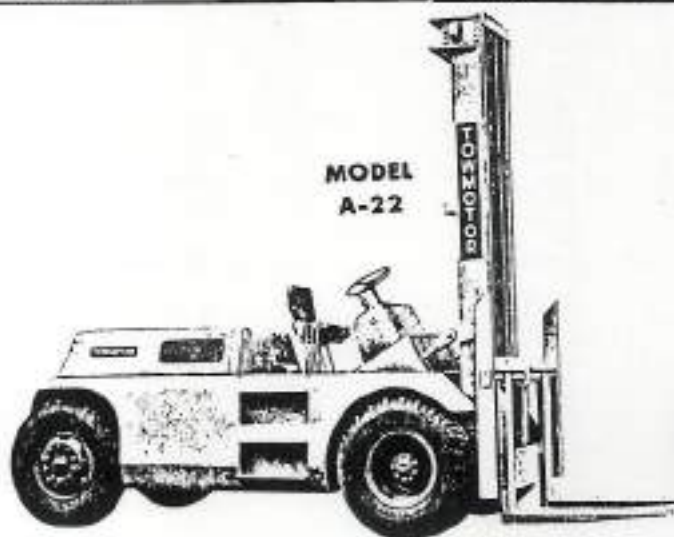

**MODEL
A-22**

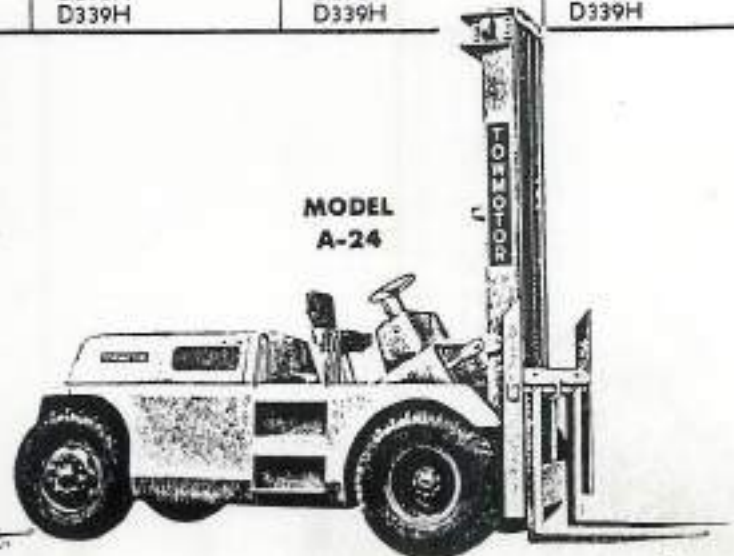

**MODEL
A-24**

Model H

Model M

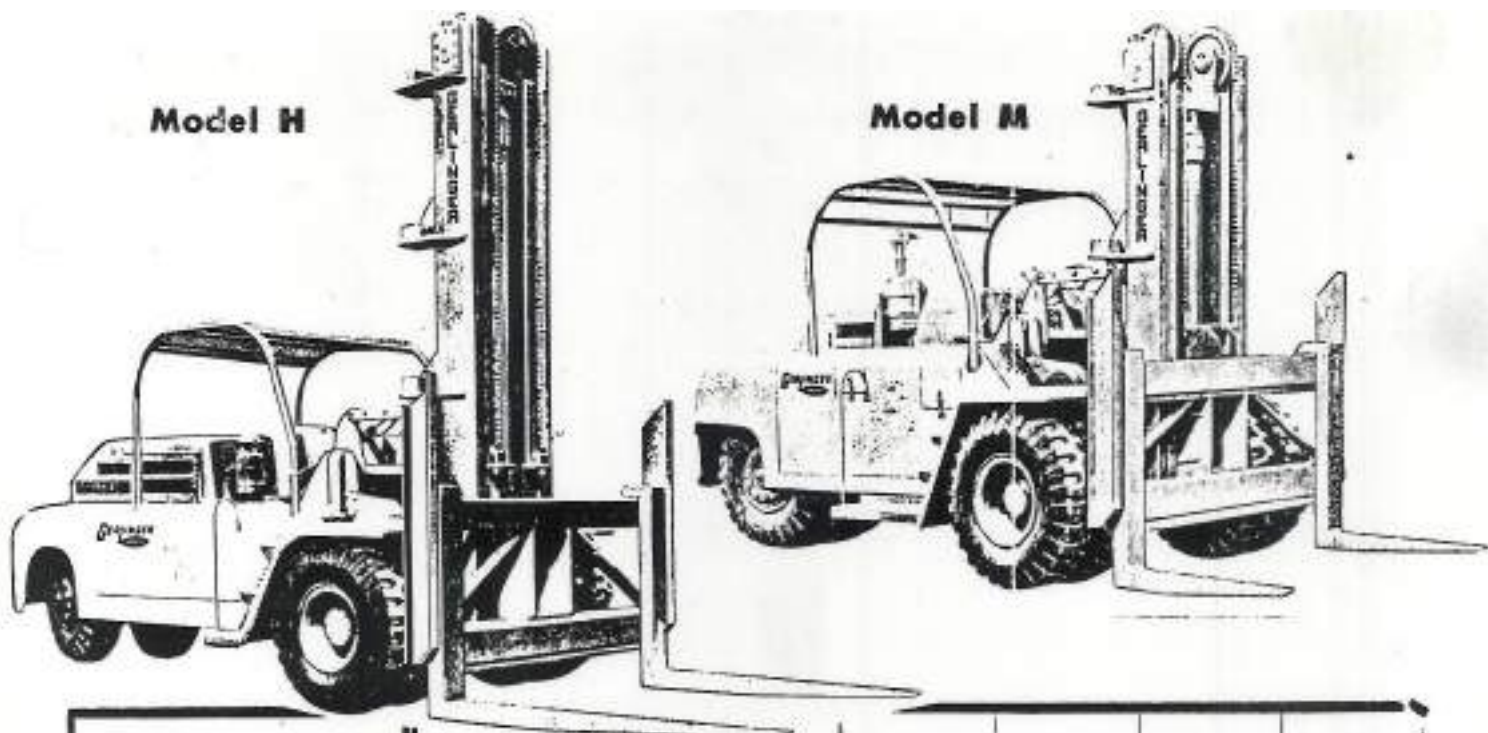

MODEL	H-32	H-36	H-40	M-24	M-26	M-28	M-30
Capacity	35,000 lbs.	36,000 lbs.	40,000 lbs.	24,000 lbs.	26,000 lbs.	28,000 lbs.	30,000 lbs.
Load Center	36"	36"	36"	36"	36"	36"	36"
Inch-Pound Rating with 125% Safety Factor	2,400,000 in.-lbs.	2,705,000 in.-lbs.	3,000,000 in.-lbs.	1,750,000 in.-lbs.	1,900,000 in.-lbs.	2,045,000 in.-lbs.	2,190,000 in.-lbs.
Inch-Pound Rating BALANCED	2,240,000 in.-lbs.	2,645,000 in.-lbs.	4,050,000 in.-lbs.	2,370,000 in.-lbs.	2,570,000 in.-lbs.	2,760,000 in.-lbs.	2,960,000 in.-lbs.
Height Mast Lowered	19' 2"	19' 2"	19' 2"	19' 1/2"	19' 1"	19' 1 1/4"	19' 2 1/2"
Height Mast Extended	17'	17'	17'	16' 10 1/2"	16' 11"	16' 11 3/4"	17 1/4"
Height of Lift	10' 0"	10' 0"	10' 0"	10' 0"	10' 0"	10' 0"	10' 0"
Speed of Lift Loaded	35 fpm	35 fpm	35 fpm	24 fpm	24 fpm	24 fpm	24 fpm
Speed of Lift Empty	38 fpm	38 fpm	38 fpm	28 fpm	28 fpm	28 fpm	28 fpm
Speed of Travel	up to 16 mph	up to 16 mph	up to 16 mph	up to 16 mph	up to 16 mph	up to 17 mph	up to 15 mph
Fork Spacing Inside to Outside	0" to 108"	0" to 108"	0" to 108"	0" to 100"	0" to 100"	0" to 100"	0" to 100"
Fork Length	79"	79"	79"	48"	48"	48"	48"
Fork Section	4" x 9"	4" x 9"	4" x 9"	4" x 7"	4" x 7"	4" x 7"	4" x 7"
Tilt Forward	6°	6°	6°	6°	6°	6°	6°
Tilt Backward	10°	10°	10°	10°	10°	10°	10°
Overall Width	113 1/2"	113 1/2"	113 1/2"	106"	106 1/2"	107 1/2"	110 1/2"
Wheelbase	132"	129"	129"	158"	158"	158"	158"
Overall Length Less Forks	252"	255"	251"	235"	235"	235"	235"
Overall Length With Forks	324"	327"	323"	283"	283"	283"	283"
Turning Radius	48"	48"	48"	49"	49"	49"	49"
Tail Swing	257"	260"	260"	236"	236"	236"	236"
Min. Width of Intersecting Aisle for 90° Turn	209"	212"	214"	188"	188"	188"	188"
Underclearance Aisle	20 1/2"	20 1/2"	20 1/2"	16 1/2"	16 1/2"	17 1/2"	18"
Underclearance Mast	19 1/2"	19 1/2"	19 1/2"	12"	12 1/2"	13 1/4"	13 1/2"
Tires	14.00 x 24 20 ply	14.00 x 24 20 ply	14.00 x 24 20 ply	10.00 x 20 12 ply	11.00 x 20 14 ply	12.00 x 20 16 ply	13.00 x 20 20 ply
Total Weight	45,714 lbs.	47,630 lbs.	49,600 lbs.	38,850 lbs.	39,900 lbs.	40,950 lbs.	43,000 lbs.
Weight on Drive Wheels	26,884 lbs.	26,430 lbs.	26,200 lbs.	23,350 lbs.	23,000 lbs.	22,750 lbs.	22,500 lbs.
Weight on Steer Wheels	18,850 lbs.	21,200 lbs.	23,600 lbs.	15,600 lbs.	16,900 lbs.	18,200 lbs.	19,500 lbs.
Ram Size	9 1/2"	9 1/2"	9 1/2"	8 1/2"	8 1/2"	8 1/2"	8 1/2"
Axle C/h. to Face of Carriage	39"	39"	39"	37"	37"	37"	37"
Wheel Brakes 1 Vacuum Booster on Models S, G, & W	16 1/2" x 7" Full air actuated	16 1/2" x 7" Full air actuated	16 1/2" x 7" Full air actuated	16 1/2" x 7" Full air actuated	16 1/2" x 7" Full air actuated	16 1/2" x 7" Full air actuated	16 1/2" x 7" Full air actuated
Engine	E	E	E	D	D	D	D

A. STANDARD—Continental Model E-244, 6 cyl.
OPTIONAL—Ford V-8 Ind., Model J, OHV
(At Extra Cost)—Hercules G1 298, 6 cyl.
Hercules Diesel D1 298, 6 cyl.—85 H.P.

B. STANDARD—Continental Model M-130, 6 cyl.
OPTIONAL—Ford V-8 Ind., Model J, OHV
Hercules G1 290, 6 cyl.
(At Extra Cost)—Hercules Diesel DD 298, 6 cyl.—85 H.P.

C. STANDARD—Ford V-8 Ind., Model J, OHV
OPTIONAL—Hercules G1 298, 6 cyl.
(At Extra Cost)—Hercules Diesel DD 298, 6 cyl.—85 H.P.

D. STANDARD—Continental Model M-363, 6 cyl.
OPTIONAL—Ford V-8 Ind., Model L, OHV
Hercules G1 319, 6 cyl.
(At Extra Cost)—Hercules Diesel DD 319, 6 cyl.—100 H.P.

E. STANDARD—Continental Model T-6471, 6 cyl.
(At Extra Cost)—Continental Diesel, 6 cyl.—147 H.P.

MODEL U-6
6000 lbs. Capacity

MODEL U-8
8000 lbs. Capacity

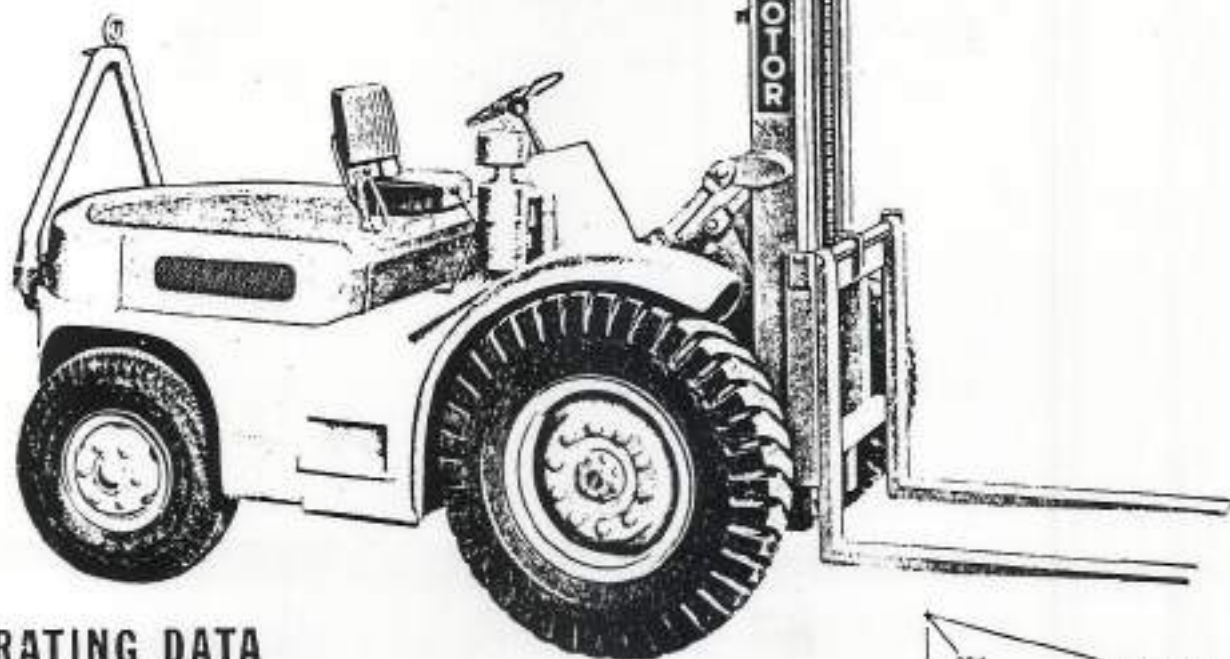

OPERATING DATA

	U-6	U-8
Capacity.....	6,000 lbs. 300,000 in.-lbs.	8,000 lbs. 400,000 in.-lbs.
Load Center.....	24"	24"
Height of Mast Lowered.....	9'6 $\frac{1}{2}$ "	9'6 $\frac{1}{2}$ "
Height of Mast Extended.....	15'6 $\frac{1}{2}$ "	15'6 $\frac{1}{2}$ "
Height of Carriage Raised.....	15'6 $\frac{1}{2}$ "	15'6 $\frac{1}{2}$ "
Height of Lift.....	12'0"	12'0"
Speed of Lift Loaded.....	65 fpm	60 fpm
Speed of Lift Empty.....	75 fpm	75 fpm
Speed of Travel.....	35 mph	35 mph
Fork Spacing Inside to Outside.....	2" to 48"	2" to 48"
Fork Length.....	48"	48"
Fork Section.....	2" x 5"	2" x 5"
Tilt Forward.....	10°	10°
Tilt Backward.....	12°	12°
Overall Width.....	81 $\frac{1}{4}$ "	81 $\frac{1}{4}$ "
Wheelbase.....	80"	80"
Overall Length Less Forks.....	140"	140"
Overall Length With Forks.....	188"	188"
Inside Turning Radius.....	36"	36"
Outside Turning Radius.....	144"	144"
Min. Width of Intersecting Aisle for 90° turn.....	120"	120"
Tires-Drive (Front).....	12.00 x 24 6 ply	12.00 x 24 8 ply
Steer (Rear).....	8.25 x 15 12 ply	9.00 x 15 12 ply
Total Weight Empty.....	11,790 lbs.	12,900 lbs.
Empty Weight on Drive Wheels.....	6,920 lbs.	6,400 lbs.
Empty Weight on Steer Wheels.....	4,870 lbs.	6,500 lbs.
CL of Axle to Face of Fork.....	26"	26"
Wheel Brakes.....	12" x 2 $\frac{1}{2}$ "	12" x 2 $\frac{1}{2}$ "
Engine, Standard.....	Continental F-244	F-244

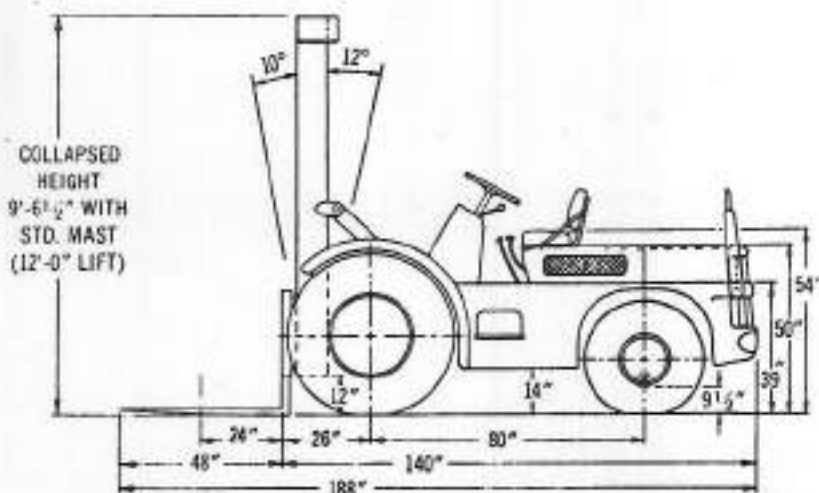
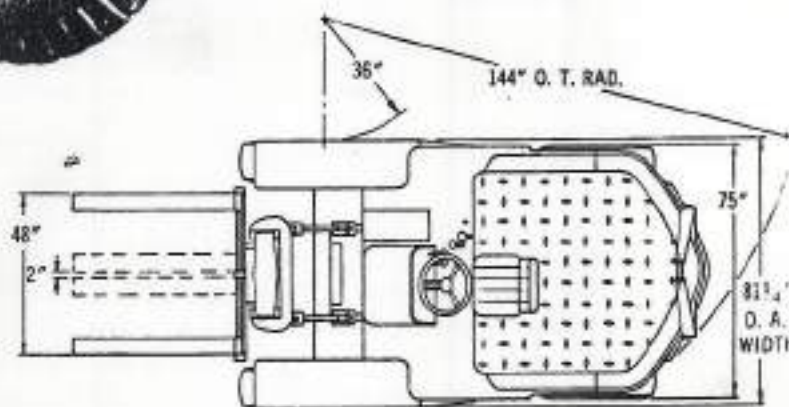

MODEL 590SG4024 NARROW-AISLE STACK

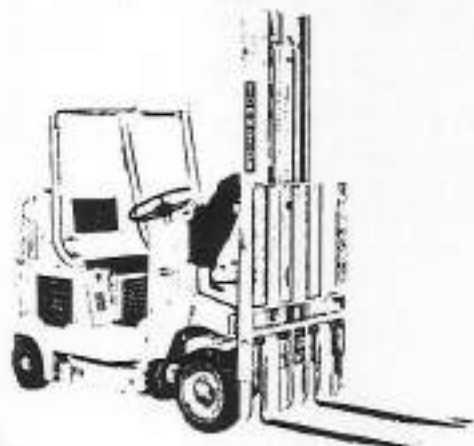

Capacity, Lbs.	4000
Load Center	24"
Inch-Pound Rating	149,000
Centerline of Drive Axle to Fork Face	13 1/2"
Maximum Lift Height with Rated Load	144"
Maximum Fork Height	148 1/2"
Mast Lowered Height	90"
Mast Extended Height	Less Load Backrest: 164 1/2" With Load Backrest: 194"
Free Lift	17 1/2"
Truck Weight, Lbs.	7200
Tilt: Conventional	Forward: 3" Backward: 5"
Stacking	Forward: Up to 3" Backward: Up to 5"

Speed of Lift, Loaded	75 fpm
Speed of Travel	Up to 8.0 mph
Carriage Width	36"
Carriage Height	Less Load Backrest: 20 1/4" With Load Backrest: 50"
Forks, Standard Section and Length	1 1/2" x 4" x 36"
Lateral Adjustment, In to In	6 1/2"
Lateral Adjustment, Out to Out	33 1/2"
Turning Radius	Outside: 82 1/2" Inside: 5 1/2"
Minimum Intersecting Aisle	67 1/2"
Minimum Aisle for Right Angle Stacking:	
Conventional	95 1/2" Plus Load Length
Narrow Aisle—36" x 36" Load	72"
Narrow Aisle—48" x 48" Load	84 1/2"
Overall Width	36 1/2"
Wheelbase	59"
Overall Length, Less Forks and Towing Eye	91 1/2"
Driver's Overhead Guard Height	71"
Effective Seat Height	32"
Tread, Steer—Drive	30 1/2" - 30 1/2"
Tire Size:	
Steer	13 1/2" x 5 1/2" x 8"
Drive	18" x 6" x 12 1/2"
Outrigger	9" x 5" x 5" Solid
Underclearance, Center of Truck	4 1/2"
Engine, Continental Model	F-112
Optional Power Types Available	LP-Gas

TOWMOTOR INDUSTRIAL TRACTORS



MODEL	KS-30	KS-33	KS-36	KS-40
Drawbar Capacity, Lbs. . . .	3000	3300	3600	4000
Capacity Trailing Load on Dry Level Concrete—Tons.	73	80	88	98
Tractor Weight, Lbs.	3000	3950	4260	4550

Speed of Travel	Up to 10.0 mph	Effective Seat Height	43"
Turning Radius	Outside: 54" Inside: 5 1/2"	Tread, Steer—Drive	33 1/2" - 30 1/2"
Minimum Intersecting Aisle	53"	Tire Size, Steer	17" x 4 1/2" x 12 1/2"
Overall Height	54 1/2"	Tire Size, Drive	22" x 8" x 16"
Overall Width	40 1/2"	Underclearance, Center of Truck	11"
Overall Length, Less Towing Eyes	67"	Engine, Continental Model	F-163
Wheelbase	36 1/2"	For more detailed information, ask for Literature Sheet Number	F-13

TOWMOTOR ELECTRIC PALLET TRUCK

Model "W"
Capacity 4,000 lbs.

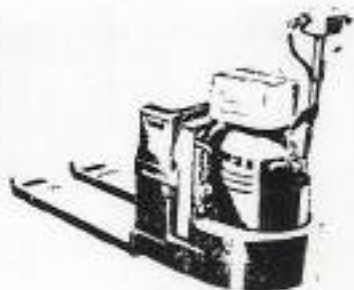

Speed of Travel	3.3 mph Empty, 2.2 mph Loaded
Lift Height	4"
Lifting Time	5 Seconds (4000 lbs. Load)
Lowering Time	4 Seconds (Controlled by Solenoid Flow Valve)
Forks, Standard Length	30", 36", 42", 48", 54", 60", 66", 72"
Forks, Standard Width	9"
Forks, Outside to Outside Width	27"
Forks, Height in Lowered Position	3 1/4"
Length, Overall, Handle Vertical	30" plus fork length
Length, Overall, Handle Horizontal	51" plus fork length
Width, Overall	27" with Lead-Acid Type Battery 29" with Edison Type Battery
Height, Overall, Handle Vertical	46"
Underclearance	Forks Lowered: 1" Forks Raised: 3 1/4" with 48" Forks
Wheelbase	Forks Lowered: 12 1/2" plus fork length Forks Raised: 9" plus fork length
Steering Arc	190 Degrees
Tires, Drive, Press-on	9 1/2" x 5" x 5" Non-Skid
Tires, Trailer, Special:	
30" Forks	3 1/4" O.D. x 6" width Single Steel
36" through 72" Forks	3 1/4" O.D. x 3" width Dual Rubber
Weight without Battery	920 lbs. (with 48" Forks)
Weight with Lead-Acid Battery	1280 lbs.
Weight with Edison Battery	1240 lb.