

Brochure Design: GK Design, Soken Hiroshima Inc. 2015.11

Aisle width (unit: mm)		Pallet length: L, Pallet width: W		*The table below indicates the value during AWC (small turn radius control) "Stacking Mode".										
Model	Type	Mast	Battery	Intersecting (IA) and Right-angle aisle width					Right-angle stacking (SA) aisle width *1					
				L	800	1,000	1,000	1,000	1,100	800	1,000	1,000	1,000	1,100
1.0 ton	8FBR10 S(J)XII	typeS Front (side)	Standard/Semi-free	201 (front)	1,550	1,560	1,570	1,610	1,570	2,060	2,210	2,230	2,250	2,320
				201 (side), 260	1,550	1,560	1,570	1,610	1,570	2,070	2,220	2,240	2,270	2,330
				280-370	1,560	1,560	1,570	1,610	1,580	2,130	2,290	2,310	2,330	2,400
				201, 260	1,560	1,560	1,570	1,610	1,580	2,100	2,250	2,270	2,290	2,360
				280-370	1,560	1,560	1,570	1,610	1,580	2,160	2,320	2,330	2,360	2,430
				201, 260	1,560	1,560	1,570	1,610	1,580	2,100	2,250	2,270	2,290	2,360
1.25 ton	8FBR13 S(J)XII	typeS Front (side)	Standard/Semi-free	201 (front)	1,630	1,630	1,640	1,690	1,650	2,060	2,210	2,230	2,260	2,320
				201 (side), 260	1,630	1,630	1,640	1,690	1,650	2,070	2,220	2,240	2,270	2,330
				280-370	1,640	1,640	1,650	1,690	1,650	2,140	2,290	2,310	2,330	2,400
				201, 260	1,640	1,640	1,650	1,690	1,650	2,100	2,250	2,270	2,290	2,360
				280-370	1,640	1,640	1,650	1,690	1,650	2,160	2,320	2,330	2,360	2,430
				201, 260	1,640	1,640	1,650	1,690	1,650	2,100	2,250	2,270	2,290	2,360
1.35 ton	8FBR14 S(J)XII	typeS Front (side)	Standard/Semi-free	201 (front)	1,630	1,630	1,640	1,690	1,650	2,060	2,210	2,230	2,260	2,320
				201 (side), 260	1,630	1,630	1,640	1,690	1,650	2,070	2,220	2,240	2,270	2,330
				280-370	1,640	1,640	1,650	1,690	1,650	2,140	2,290	2,310	2,330	2,400
				201, 260	1,640	1,640	1,650	1,690	1,650	2,100	2,250	2,270	2,290	2,360
				280-370	1,640	1,640	1,650	1,690	1,650	2,160	2,320	2,330	2,360	2,430
				201, 260	1,640	1,640	1,650	1,690	1,650	2,100	2,250	2,270	2,290	2,360
1.5 ton	8FBR15 C(J)XII	typeC Front (side)	Standard/Semi-free	260	1,690	1,690	1,700	1,740	1,700	2,090	2,230	2,250	2,280	2,340
			Full-free	260	1,690	1,690	1,700	1,740	1,700	2,100	2,250	2,270	2,300	2,360
			3-stage full-free	260	1,690	1,690	1,700	1,740	1,700	2,100	2,250	2,270	2,300	2,360
	8FBR15 S(J)XII	typeS Front (side)	Standard/Semi-free	280-370	1,690	1,690	1,700	1,740	1,700	2,140	2,290	2,310	2,330	2,400
			2-stage full-free	280-370	1,690	1,690	1,700	1,740	1,710	2,160	2,320	2,330	2,360	2,430
			3-stage full-free	280-370	1,690	1,690	1,700	1,740	1,710	2,160	2,320	2,330	2,360	2,430
8FBR15 A(J)XII	typeA Front (side)	Standard/Semi-free	280-370	1,800	1,790	1,800	1,840	1,810	2,140	2,290	2,310	2,340	2,400	
		2-stage full-free	280-370	1,800	1,790	1,800	1,850	1,810	2,190	2,360	2,370	2,390	2,470	
		3-stage full-free	280-370	1,800	1,790	1,800	1,850	1,810	2,190	2,360	2,370	2,390	2,470	
8FBR15 W(J)XII	typeW Front (side)	3-stage full-free	280-370	1,850	1,850	1,850	1,870	1,860	2,190	2,360	2,370	2,390	2,470	
1.8 ton	8FBR18 S(J)XII	typeS Front (side)	Standard/Semi-free	280-370	1,800	1,790	1,800	1,840	1,810	2,140	2,290	2,310	2,340	2,400
			2-stage full-free	280-370	1,800	1,790	1,800	1,850	1,810	2,190	2,360	2,370	2,390	2,470
			3-stage full-free	280-370	1,800	1,790	1,800	1,850	1,810	2,190	2,360	2,370	2,390	2,470
	8FBR18 A(J)XII	typeA Front (side)	Standard/Semi-free	280-370	1,820	1,820	1,830	1,870	1,840	2,170	2,320	2,340	2,370	2,430
			2-stage full-free	280-370	1,820	1,820	1,830	1,870	1,840	2,220	2,390	2,400	2,420	2,500
			3-stage full-free	280-370	1,820	1,820	1,830	1,870	1,840	2,220	2,390	2,400	2,420	2,500
8FBR18 W(J)XII	typeW Front (side)	3-stage full-free	280-370	1,850	1,850	1,850	1,870	1,860	2,190	2,360	2,370	2,390	2,470	

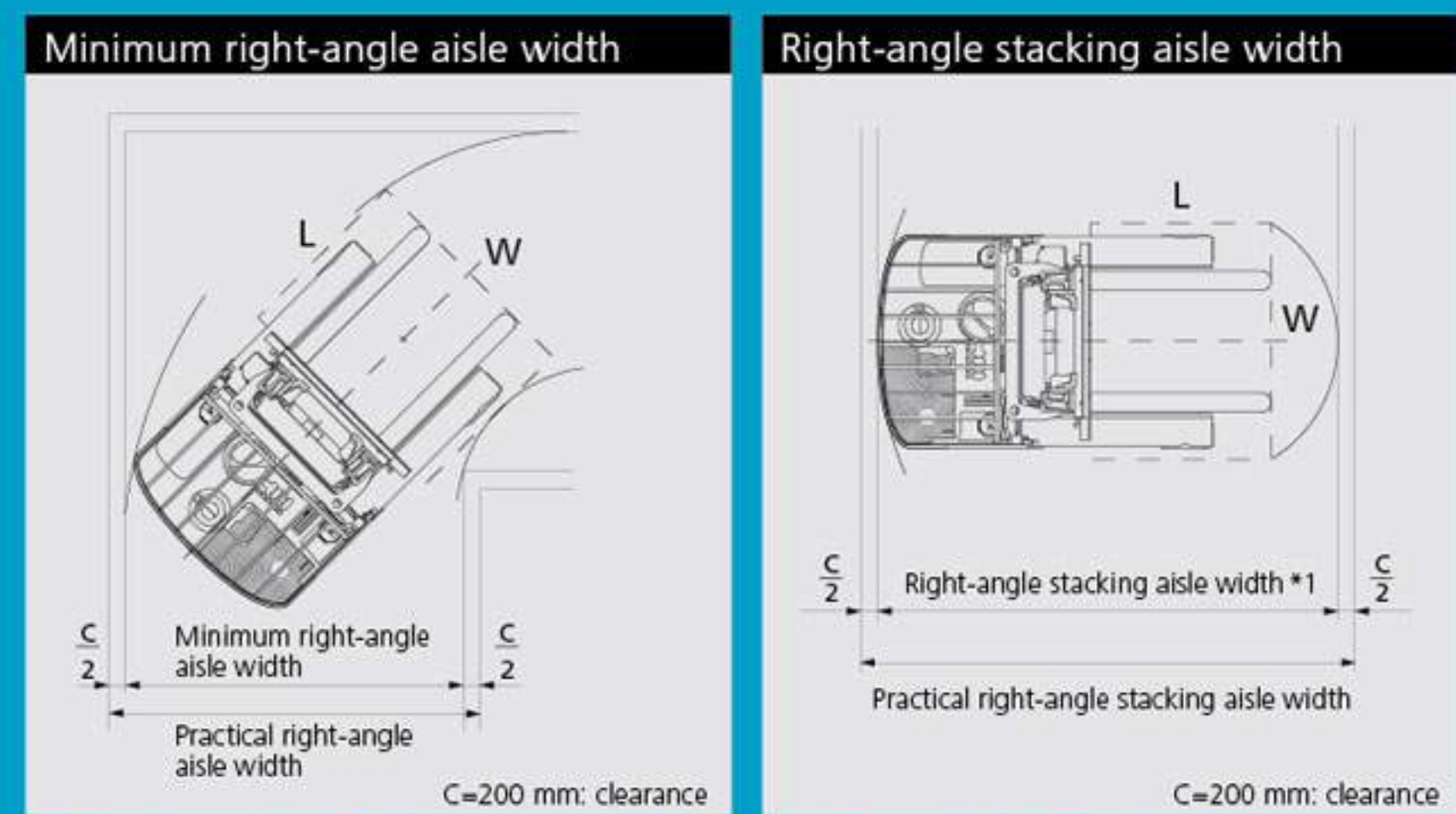

For the forklift driver operations, inspection and maintenance, always read the instruction manual and follow the instructions correctly.



*1: Figure does not include the turning capacity of 200 mm in the practical right-angle stacking aisle width.

Manufactured by
SUMITOMO NACCO FORKLIFT CO.,LTD.
 2-75, Daitoh-cho, Obu-shi, Aichi-ken, 474-8555 JAPAN
 Phone: 81-562-48-5251 Fax: 81-562-48-5396

We offer personalized after service and looking forward to see you.

QuaPro-R

Electric Reach Forklift Trucks

1.0 TON — 1.8 TON

- 8FBR 10 · 13 · 14 · 15 · 18 S(J)XII
- 8FBR 15 C(J)XII
- 8FBR 15 · 18 A(J)XII
- 8FBR 15 · 18 W(J)XII

The 4 "PRO" in response to the customer's voice.
 QuaPro-R has greatly advanced in load handling operations.

PROFESSIONAL
PRODUCTIVE
PROFITABLE
PROGRESSIVE



SUMITOMO NACCO FORKLIFT SALES CO.,LTD.
 2-18, Heiwajima 3-chome, Ota-ku, Tokyo, 143-0006 JAPAN
 Phone: 81-3-6404-3262 Fax: 81-3-6404-3272

CODE
ER-01E

*The actual features and specifications may differ from those described in the catalog.
 *The color of the photographs in this catalog may differ slightly from the actual color depending on the ink quality.



