

## **Robust, powerful, manoeuvrable and reliable ride-on electric pallet trucks.**



The ride-on electric low lift pallet trucks model 320 P5 (20 tons capacity and mechanical guide in standard version) and 325 P5 (25 tons capacity and servo-assisted tiller in standard version) are ideal for quick handling of goods on long travel distances and for loading and unloading of lorries on logistic platforms, where robustness, manoeuvrability, power and reliability are essential requirements for logistic processes' optimisation. The OMG pallet trucks models 320 P5 – 325 P5 use a new ac technology that ensures lower power consumption and high performance. The trucks are easy to use and efficient in small spaces thanks to their size. Not only high performance, but also care for the operator: comfortable controls positioning and maximum safety ensured by the automatic return of the tiller to standby position when released.

### **Electronic system**

The entire range of OMG low lift pallet trucks is equipped with ac electronic devices that can operate in high temperature conditions, without any truck stops. The controls are equipped with anti roll-back devices which control and check all machine functions and allow unlimited adjustments for performance optimisation, adapting the truck to the operation to be carried out. All electric drive and braking parameters can be set electronically from a control panel, according to customer's requirements. All models are equipped with timer and battery level indicator with auto-lock function that switches on once 80% of the battery capacity is discharged.

### **Drive**

Powerful and reliable three-phase ac traction motors, able to satisfy even the most demanding requests for performance, providing the necessary amount of power every time, as the speed of the truck can be adjusted by changing the position of the throttle.

### **Braking system**

There are three braking systems in this range:

- braking by reversing the running direction and releasing the throttle (service braking that can be adjusted from the control panel);
- emergency braking that takes place automatically if the tiller is suddenly

- released or lowered (electromagnetic brake);
- parking brake.

## Frame

Made of bended sheet metal to minimise any tensions induced by welds, ensuring maximum mechanical resistance over time. The frame has been painted using cutting edge equipment. The battery compartment can be

easily opened by lifting the cover, simplifying the daily and periodical battery recharge and check operations. Particular attention has been paid to provide easy access to wear parts, minimising therefore the routine maintenance costs. The forks are made of high strength steel.

---

## Additional versions

- 325 P5 ac with fixed platform and backrest
- 325 P5 ac with fixed platform and lateral guards (Ben-Hur version)
- 325 P5 ac with mast and initial lift



---

## Driving comfort

- The central operator workstation located inside the chassis protects the operator while offering him excellent visibility.
- Comfortable operator platform with cushioned footrest.
- Strong and robust armrests covered in polyurethane.
- Spring lever for lateral armrests unlocking, allowing you to switch from a ride-on truck to a walk behind truck in just a few seconds.



---

## Tiller

Result of a meticulous ergonomic study that combines operating comfort with modern industrial design. The tiller is fitted with easy to reach controls, ensuring enhanced productivity, precision and efficiency. When released, the tiller returns smoothly to its vertical position thanks to the gas spring fitted with slowdown limit switch.

- tiller head made of ABS with steel core, able to absorb heavy impact without deformation;
- push-buttons located on both sides of the tiller for lifting and lowering the forks;
- acoustic warning button in the centre of the tiller head;
- active safety system with suitably positioned anti-crush device for walk behind setup.
- electrical servo-assisted tiller on model 325 P5 ac.



---

## Lateral battery extraction

- standard on model 325 P5 ac
- optional on model 320 P5 ac with 24V 375Ah battery.
- Laterally hinged battery case made of polyethylene.
- battery compartment placed on steel rollers for readily battery replacement when using the truck for multiple work shifts.
- The traction battery can be easily removed using the unlocking lever and reconnected by simply inserting it in the compartment.



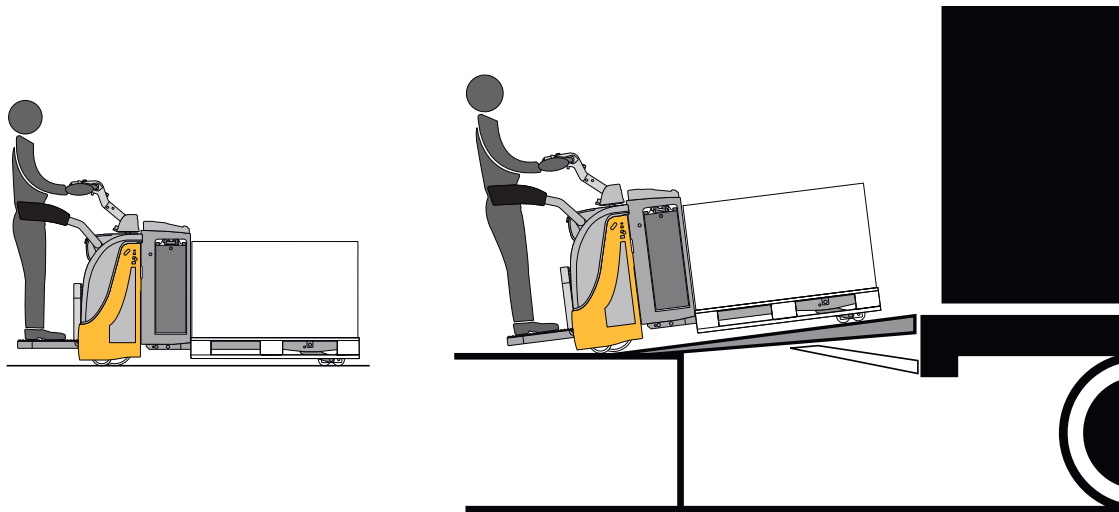
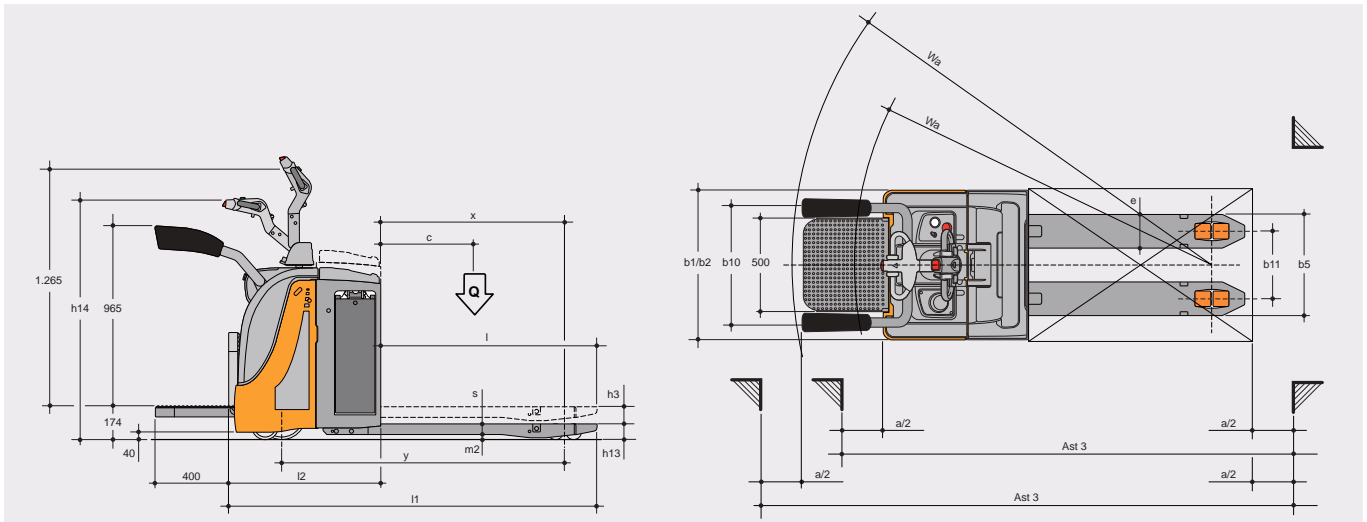

#### Accessories and special features

double front roller	lateral battery extraction (320 P5 ac with 375Ah battery)	
width over forks 540 mm	lateral battery extraction for model 325 P5 ac	
width over forks 680 mm	simple battery extraction roller (320 P5 ac with 375Ah battery)	
supertrack drive wheel	double battery extraction roller with wheels (320 P5 ac with 375Ah battery)	
polyurethane drive wheel	electronic braking system	
12 km/h speed for model 320 P5 ac	anti roll-back device	
12 km/h speed for model 325 P5 ac	electronic speed control	
fixed platform with backrest	electromagnetic parking brake	
fixed platform with lateral guards (Ben-Hur version)	protection for cold store	
access keypad with pin code	electric servo-assisted tiller (only available on model 325 P5 ac)	
central battery recharger	voltmeter-timer, auto-lock function when 80% of the battery capacity is discharged	

standard



optional



Characteristics	1.1	Manufacturer		OMG S.r.l. Single member company		
	1.2	Model		320 P5 ac	325 P5 ac	
		Execution				
	1.3	Operation		Electric		
	1.4	Operator position		Ride-on / At ground level		
	1.5	Capacity	Q	t	2.0	2.5
	1.6	Load centre of gravity	c	mm	600	
	1.8	Load distance	x	mm	978	
	1.9	Wheel centre distance	y	mm	1,506	
Weights	2.1	Truck weight incl. battery (see line 6.5)		kg	820	825
	2.2	Weight on axis with front / rear load		kg	1,700 / 1,135	2,100 / 1,169
	2.3	Weight on axis without front / rear load		kg	150 / 650	160 / 665
Wheels Frame	3.1	Wheels and tyres		mm	polyurethane	
	3.2	Front wheels size		mm	245 / 150	
	3.3	Rear wheels size		mm	85	
	3.4	Stabiliser wheels size		mm	150	
	3.5	Number of front / rear wheels (x = drive)		no.	1x + 2 / 4	
	3.6	Front track	b10	mm	536	
	3.7	Rear track	b11	mm	360	
Base dimensions	4.4	Forks lifting stroke		h3	mm	120
	4.9	Tiller height in min. /max. driving position		h14	mm	998 / 1,170
	4.15	Forks lowered height		h13	mm	85
	4.19	Overall length		l1	mm	2,345 / 1,915
	4.20	Length including forks heel		l2	mm	1,195 / 765
	4.21	Overall width		b1	mm	790
	4.22	Forks size		s/e/l	mm	60 / 180 / 1,150
	4.25	Width over forks		b5	mm	540
	4.32	Clearance at mid stroke		m2	mm	30
	4.33	Working aisle width with 1000 x 1200 transversal pallet		Ast	mm	3,028 / 2,698
	4.34	Working aisle width with 800 x 1200 longitudinal pallet		Ast	mm	2,883 / 2,533
4.35	Turning radius		Wa	mm	2,228 / 1,898	
Performance	5.1	Speed with / without load		km/h	8.5	12
	5.2	Lifting speed with / without load		m/s	0.04 / 0.05	
	5.3	Lowering speed with/without load		m/s	0.26 / 0.06	
	5.8	Max. feasible gradient with / without load		%	10 / 18 - 7 / 15	
	5.10	Service brake		Electromagnetic		
Electric motors	6.1	Traction motor, 60 min performance with S2		kW	2.6	
	6.2	Lift motor, 15% performance with S3		kW	2.0	
	6.3	Battery as per DIN 43531 / 35 / 36 A, B, C, no		no		
	6.4	K5 battery voltage, nominal capacity		V/Ah	24 / 250 - 375*	24 / 375 - 460*
	6.5	Battery weight		kg	215 / 295	295 / 390
	6.6	Power consumption as per VDI cycle		kW/h		
Miscellaneous	8.1	Type of electronic system		AC		
	8.4	Noise threshold as per EN 12 053		dB(A)	< 70	
						* optional

Technical data sheet referring to pallet truck in standard version; data determined in compliance with VDI 2198. These values may differ if your product is fitted with other types of wheels and tires, supports and accessories. All data and images herein are indicative, OMG S.r.l. Single member company reserves the right to modify the documentation without prior notice.