

SERVICE & MAINTENANCE MANUAL

Electric Pallet Truck

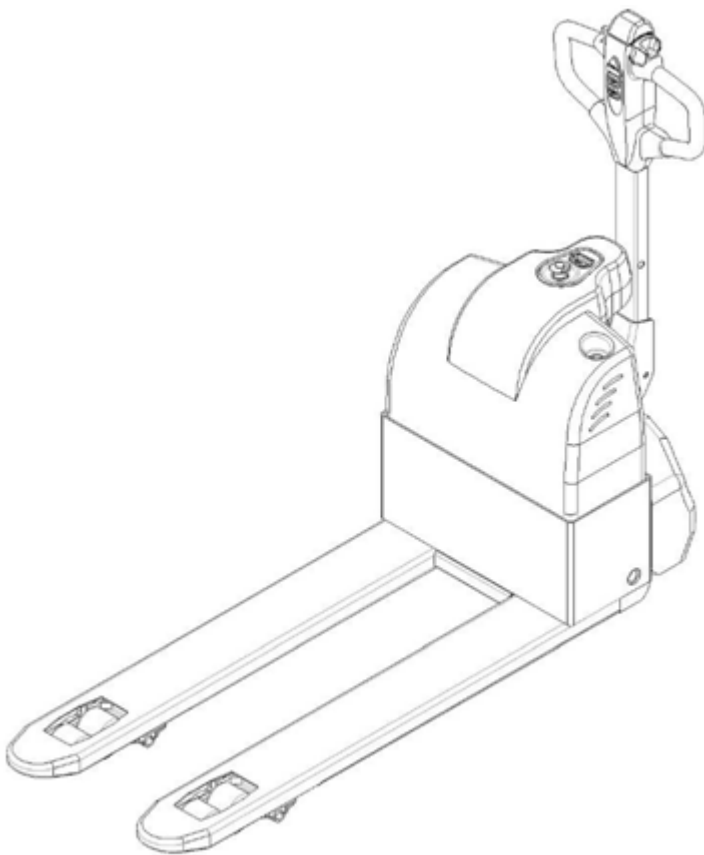

Version 12/2012

EPT -SHFW-001

CONTENT

FOREWORD	3
1. GENERAL	4
1.1 INTRODUCTION – MAINTENANCE SAFETY PRECAUTIONS	4
1.2 MEASUREMENT CONVERSIONS	8
2. SPECIFICATION	13
2.1 LOCATION OF COMPONENTS.....	13
2.2 SPECIFICATION SHEETS.....	14
2.2.1 TECHNICAL FEATURES	14
2.3 LUBRICATION	17
3. ELECTRIC SYSTEM	18
3.1 ELECTRIC DIAGRAM	18
3.2 ELECTRICAL INSTALLATION	22
3.3 DRIVE WHEEL.....	23
3.4 PUMP STATION	23
3.5 BATTERY.....	23
3.6 CHARGER	25
3.7 CURTIS CONTROLLER 1212.....	28
3.8 BATTERY DISCHARGE INDICATOR	39
3.9 REPLACE THE ELECTRIC PARTS.....	41
3.10 TOOL FOR REPAIRING THE PIN OF ELECTRIC PLUG	46
4. HYDRAULIC SYSTEM.....	48
4.1 PUMP STATION OPERATION	49
4.2 OPERATION OF CYLINDER	54
4.3 HYDRAULIC OIL FILLING.....	55
5. DRIVE WHEEL.....	56
5.1 REPLACE THE WHEEL.....	57
5.2 REPLACE THE ELECTRIC BRUSH.....	58
5.3 REPLACE THE BRAKE.....	59
5.4 ADJUST THE AIR GAP OF THE BRAKE	59
5.5 REPLACE THE DRIVE WHEEL	60
6. CONTROL HANDLE	57
6.1 REMOVE THE AIR SPRING.....	65
6.2 REMOVE THE HANDLE	65
6.3 REPLACE THE SENSOR	66
6.4 REPLACE THE TILLER.....	66
6.5 REPLACE THE ACCELERATOR.....	67
6.6 REPLACE THE MICRO SWITCHES.....	68
7. CASTER WHEEL	69
7.1 OPERATION OF THE CASTER WHEEL.....	69
7.2 ADJUSTING THE PRESSURE FOR THE DRIVE WHEEL.....	70
8. MAINTENANCE CHECK LIST.....	71
9. TROUBLE SHOOTING	73

FOREWORD

Proper operation, maintenance, troubleshooting and repairs are necessary to preserve the performance of the pallet truck over a long period and ensure that fault and breakdowns do not occur. The purpose of this service manual is to provide necessary information especially in inspections, repair and maintenance.

⚠ WARNING The majority of this pallet truck consists of steel, it can be completely recycled. Waste material in conjunction with repairs, maintenance, cleaning or scrapping, must be collected and disposed of in an environment-friendly way and in accordance with the directives of respective countries. Such work must be carried out in areas intended for this purpose. Recyclable material should be taken care of specialized authorities. Environmentally hazardous waste, such as oil filters, batteries and electronics, will have a negative effect on the environment or health, if handled incorrectly.

⚠ CAUTION All of the information reported herein is based on data available at the moment of printing. Our products are constantly being developed and renewed, we reserves the right to modify our own products at any moment without prior notice and incurring in any sanction. So, it is suggested to always verify possible updates.

1. GENERAL

1.1 INTRODUCTION – MAINTENANCE SAFETY PRECAUTIONS

Maintenance work may cause injuries. Always take care to perform work safe, at least observing the following. It is of utmost importance that maintenance personnel pay strict attention to these warnings and precautions to avoid possible injury to themselves, others or damage to the equipment. A maintenance program must be followed to ensure that the machine is safe to operate.

The specific precautions to be observed during maintenance are inserted at the appropriate point in the manual. These precautions are, for the most parts, those that apply when servicing hydraulic and larger truck component parts.

⚠ WARNING MODIFICATION OF THE TRUCK WITHOUT CERTIFICATION BY A RESPONSIBLE AUTHORITY THAT THE TRUCK IS AT LEAST AS SAFE AS ORIGINALLY MANUFACTURED, IS A SAFETY VIOLATION.

⚠ WARNING SINCE THE TRUCK MANUFACTURER HAS NO DIRECT CONTROL OVER THE FIELD INSPECTION AND MAINTENANCE, SAFETY IN THIS AREA RESPONSIBIUTY OF THE OWNER OR OPERATOR.

⚠ WARNING FAILURE TO COMPLY WITH SAFETY PRECAUTIONS, LISTED IN THIS SECTION MAY RESULT IN MACHINE DAMAGE, PERSONNEL INJURY OR DEATH AND IS A SAFETY VIOLATION.

- When carrying out any operation or maintenance, have trained and experienced personnel to carry out the work.
- When carrying out any operation or maintenance, carefully read operation and maintenance handbook.
- Read all the precautions given on the decals which are fixed to the truck.
- Be sure you fully understand the content of the operation. It is important to prepare necessary tools and parts for maintain the truck.

- Your safety, and that of others, is the first consideration when engaging in the maintenance of equipment. Always be conscious of weight. Never attempt to move heavy parts without the aid of a mechanical device. Do not allow heavy objects to rest in an unstable position. When raising a portion of the equipment, ensure that adequate support is provided.



- It should be noted that the machines hydraulic systems operate at extremely high potentially dangerous pressures. Every effort should be made to relieve any system pressure prior to disconnecting or removing any portion of the system. Relieve system pressure by cycling the applicable control several times with the engine(motor) stopped and ignition on, to direct any line pressure back into the reservoir. Pressure feed lines to system components can then be disconnected with minimal fluid loss.



- Remove all rings, watches and jewelry when performing any maintenance.
- Wear well-fitting helmet, safety shoes and working Clothes When drilling grinding or hammering always. Wear protective goggles. Always do up safety clothes properly so that they do. Not catch on protruding parts of machines. Do not wear oily clothes. When checking, always release battery plug. **DO NOT WEAR LONG HAIR UNRESTRAINED, OR LOOSE-FITTING CLOTHING AND NECKTIES WHICH ARE APT TO BECOME CAUGHT ON OR ENTANGLED IN EQUIPMENT.**

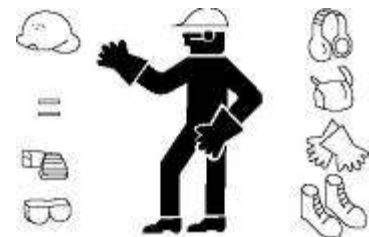

- During maintenance do not allow any unauthorized person, to stand near the machine.
- Flames should never be used instead of lamps. Never use a naked flame to check leaks or the level of oil or electrolyte.



- Immediately remove any oil or grease on the floor of the operator's compartment or on the handrail. It is very dangerous if someone slips while on the machine.

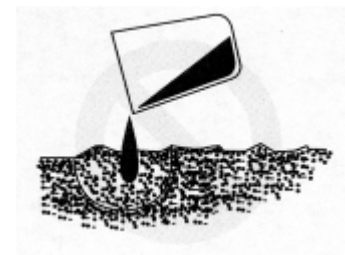

- Always use pure oil or grease, and be sure to use clean containers.

- Oil is a dangerous substance. Never handle oil, grease or oily clothes in places where there is any fire or flame. As preparation for use of fire extinguishers and other fire- fighting equipment.



- Keep the battery away from fire hazards. The generated gases are explosive.



- Store all the oils in a specified place.
- Keep the flammable things away from the machine. Do not smoke at the working place.

- Battery should always be disconnected during replacement of electrical components.

- Always use the grades of grease and oil recommended by NOBLELIFT choose the viscosity specified for the ambient temperature.

- Exhaust gas is dangerous provide ventilation when working in a closed space.
- Avoid breathing dust that may be generated when handling components containing asbestos fibers. Wear a gas mask if necessary.



- When working on top of the machine, be careful not to lose your balance and fall.

- Hand a caution sign in the operator's compartment (for example "Do not start" or "Maintenance in progress"). This will prevent anyone from starting or moving the machine by mistake.

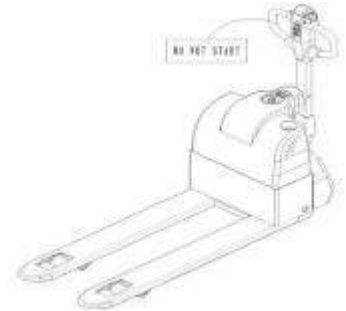

- When welding on the machine or working on the electrical system, ALWAYS turn the key switch OFF and remove the battery plug from the battery. Park the machine on firm, flat ground. Lower the fork to the min. height and stop the motor.



- Sulfuric acid in battery electrolyte is poisonous. It is strong enough to burn skin and eat holes in clothing. If you spill acid on your clothes or skin, immediately flush with large quantities of water.



- When working on the battery, wear goggles or safety glasses. If splashed into the eyes, flush with water and get medical attention immediately.

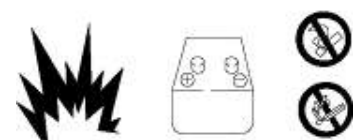

- Battery terminals touched by metal objects can cause short circuit and burn you. Keep tools away from the terminals.
- Keep sparks, lighted matches, and open flame away from the top of battery. Battery (hydrogen) gas can explode.
- When disassembling and assembling the battery, make sure that the battery terminals (+, -) are correctly connected.



- If water gets into the electrical system, abnormal operation or failure can result. Do not use water or steam on sensors, connectors and instruments in the cab.



- Do not handle electrical equipment while wearing wet gloves, or in wet places, as this can cause electric shock.
- When working with other, choose a group leader and work according to his instructions. Do not perform any maintenance beyond the agreed work.
- Unless you have special instructions to the contrary, maintenance should always be carried out with the motor stopped. If maintenance is carried out with the motor running, there must be two technicians present: One operating the stacker and the other one performing the maintenance. In such a case, never touch any moving part.
- Before making adjustment, lubricating or performing any other maintenance, shut off all power controls.
- When removing parts containing O-ring Gaskets or seal clean the mounting surface and replace with new sealing parts.
- Thoroughly clean the machine. In particular, be careful to clean the grease fittings and the area around the dipsticks. Be careful not to let any dirt or dust into the system.
- Use only approved nonflammable cleaning solvents.
- When changing the oil or filter, check the drained oil and filter for any signs of excessive metal particles or other foreign materials.
- Always use NOBLELIFT genuine parts for replacement. ENSURE REPLACEMENT PARTS OR COMPONENTS ARE IDENTICAL OR EQUIVALENT TO ORIGINAL PARTS OR COMPONENTS.
- When checking an open gear case, there is a risk of dripping things in. Before removing the covers to inspect such cases, empty everything from your pockets. Be particularly careful to remove wrenches and nuts.

1.2 MEASUREMENT CONVERSIONS

Length

Unit	cm	m	km	in	ft	yd	mile
cm	1	0.01	0.00001	0.3937	0.03281	0.01094	0.000006
m	100	1	0.001	39.37	3.2808	1.0936	0.00062
km	100000	1000	1	39370.7	3280.8	1093.6	0.62137
in	2.54	0.0254	0.000025	1	0.08333	0.02777	0.000015
ft	30.48	0.3048	0.000304	12	1	0.3333	0.000189
yd	91.44	0.9144	0.000914	36	3	1	0.000568
mile	160930	1609.3	1.6093	63360	5280	1760	1

1mm=0.1cm, 1 μ m=0.001mm

Area

Unit	cm ₂	m ₂	km ₂	a	ft ₂	yd ₂	in ₂
cm ₂	1	0.0001	–	0.000001	0.001076	0.000012	0.155000
m ₂	10000	1	0.000001	0.01	10.764	1.1958	1550.000
km ₂	–	1000000	1	10000	1076400	1195800	–
a	0.01	100	0.0001	1	1076.4	119.58	–
ft ₂	–	0.092903	–	0.000929	1	0.1111	144.000
yd ₂	–	0.83613	–	0.008361	9	1	1296.00
in ₂	6.4516	0.000645	–	–	0.006943	0.000771	1

1ha=100a, 1mile₂=259ha=2.59km₂

Volume

Unit	cm ₃ = cc	m ₃	l	in ₃	ft ₃	yd ₃
cm ₃ = m l	1	0.000001	0.001	0.061024	0.000035	0.000001
m ₃	1000000	1	1000	61024	35.315	1.30796
l	1000	0.001	1	61.024	0.035315	0.001308
in ₃	16.387	0.000016	0.01638	1	0.000578	0.000021
ft ₃	28316.8	0.028317	28.317	1728	1	0.03704
yd ₃	764529.8	0.76453	764.53	46656	27	1

1gal(US)=3785.41 cm₃=231 in₃=0.83267gal(US)

Weight

Unit	g	kg	t	oz	lb
g	1	0.001	0.000001	0.03527	0.0022
kg	1000	10	0.001	35.273	2.20459
t	1000000	1000	1	35273	2204.59
oz	28.3495	0.02835	0.000028	1	0.0625
lb	453.592	0.45359	0.000454	16	1

1 tone (metric)= 1.1023 ton(US)=0.9842 ton(UK)

Pressure

Unit	kgf/cm ₂	bar	Pa=N/m ₂	kPa	lbf/in ₂	lbf/ft ₂
kgf/cm ₂	1	0.98067	98066.5	98.0665	14.2233	2048.16
bar	1.01972	1	100000	100	14.5037	2088.6
Pa=N/m ₂	0.00001	0.001	1	0.001	0.00015	0.02086
kPa	0.01020	0.01	1000	1	0.14504	20.886
lbf/in ₂	0.07032	0.0689	6894.76	6.89476	1	144
lbf/ft ₂	0.00047	0.00047	47.88028	0.04788	0.00694	1

kgf/cm₂=735.56 Torr(mmHg)=0.96784atm

Standard tightening torque

The following charts give the standard tightening torques of bolts and nuts.

Exceptions are given in sections of "Disassembly and Assembly"

METER TABLE

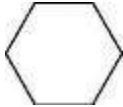
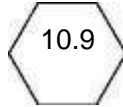
Classification	4T, 5T	10T
Bolt type		
Bolt size	Torque kgf · m (lbf · ft)	Torque kgf · m (lbf · ft)
M4	0.2 ± 0.02	0.4 ± 0.04
M5	0.3 ± 0.03	0.8 ± 0.08
M6	0.5 ± 0.05	1.4 ± 0.14
M8	1.2 ± 0.12	3.3 ± 0.3
M10	2.3 ± 0.23	6.5 ± 0.7
M12	4.0 ± 0.4	11.3 ± 1.1
M14	6.4 ± 0.6	17.9 ± 1.8
M16	9.5 ± 0.9	26.7 ± 2.7
M18	13.5 ± 1.4	38.0 ± 3.8
M20	18.6 ± 1.9	52.2 ± 5.2
M22	24.7 ± 2.5	69.4 ± 6.9
M24	32.1 ± 3.2	90.2 ± 9.0
M30	62.6 ± 6.3	176.1 ± 17.6
M36	108.2 ± 10.8	304.3 ± 30.4
M42	171.8 ± 17.2	483.2 ± 48.3
M45	211.3 ± 21.1	594.3 ± 50.4

INCH TABLE

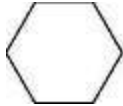
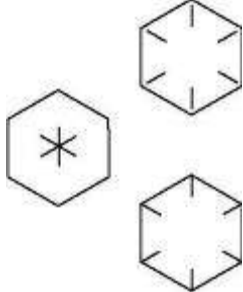
	4T, 5T	10T
Classification Bolt type		
Bolt size	Torque kgf · m (lbf · ft)	Torque kgf · m (lbf · ft)
1/4	0.6 ± 0.06	1.7 ± 0.2
5/16	1.2 ± 0.12	3.0 ± 0.3
3/8	2.0 ± 0.20	5.6 ± 0.5
7/16	3.2 ± 0.32	8.9 ± 0.9
1/2	4.7 ± 0.47	13.4 ± 1.3
9/16	6.8 ± 0.68	19.0 ± 1.9
5/8	9.3 ± 0.93	26.1 ± 2.6
3/4	16.0 ± 1.60	45.1 ± 4.5
7/8	25.5 ± 2.55	71.6 ± 7.2
1	38.0 ± 3.80	106.9 ± 10.7
1-1/8	54.1 ± 5.41	152.2 ± 15.2
1-1/4	74.2 ± 7.42	208.9 ± 20.9
1-3/4	98.8 ± 9.88	277.8 ± 27.8
1-1/2	128.2 ± 12.82	360.7 ± 36.1

The torque in above table shall not be applied to nylon or nonferrous bolts or washer. The same is valid for not standardized ones.

H Newton meter : 1 Nm = 0.1kgfm

TIGHTENING TORQUE OF SPLIT FLANGE BOLTS

The following torque shall be applied to the split flange bolts.

Diameter (mm)	Flat width (mm)	Torque	
		kgf·m	N·m
10	14	6.7 ± 0.7	66.7 ± 6.8
12	17	11.5 ± 1	112 ± 9.8
16	22	28.5 ± 3	279 ± 29



O – ring

Plug

PF THREAD

Thread	Torque (kgf·m)
1/8	1.1 ± 0.1
1/4	2.6 ± 0.2
3/8	4.6 ± 0.3
1/2	8.5 ± 0.4
3/4	19 ± 1.0
1	33 ± 2.0

TORQUE FOR SWIVEL NUT WITH O-RING

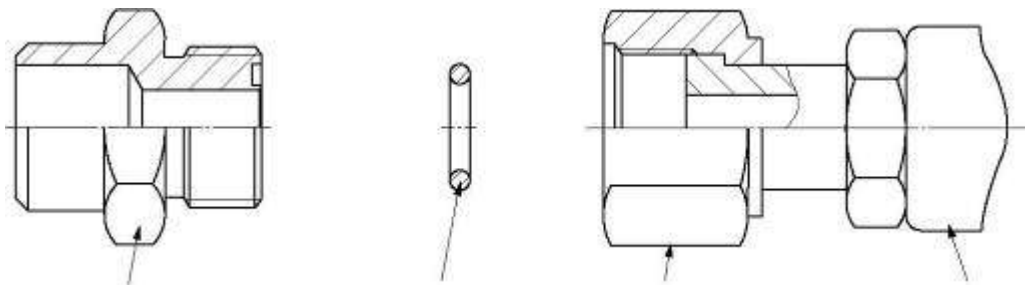

Connector

O – ring

Swivel – nut

hose

Tube O.D (inch)	Thread (in)	Torque (kgf·m)
1/2	UN 13/16 - 16	9.5 ± 0.95
3/4	UN 1 3/16 - 12	18 ± 1.8
1	UN 1 7/16 - 12	21 ± 2.1

APPROXIMATE CONVERSIONS

SI Unit	Conv Factor	Non-SI Unit	Conv Factor	SI Unit
Torque				
Newton meter (N·m)	× 8.9	= In·in	× 0.113	= N·m
Newton meter (N·m)	× 0.74	= lb·ft.	× 1.36	= N·m
Newton meter (N·m)	× 0.102	= kg·m	× 7.22	= lb·ft.*
Pressure (Pa = N/m ²)				
kiloPascal (kPa)	× 4.0	= in. H ₂ O	× 0.249	= kPa
kiloPascal (kPa)	× 0.30	= in. Hg	× 3.38	= kPa
kiloPascal (kPa)	× 0.145	= psi	× 6.89	= kPa
(bar)	× 14.5	= psi	× 0.069	= bar*
(kg/cm ²)	× 14.22	= psi	× 0.070	= bar*
Newton/mm ²	× 145.04	= psi	× 0.069	= bar*
MegaPascal (MPa) (Pa=N·m ²)	× 145	= psi	× 0.00689	= MPa
Power r (W = J/s)				
kiloWatt (kW)	× 1.36	= PS (cv)	× 0.736	= kW
kiloWatt (kW)	× 1.34	= HP	× 0.746	= kW
kiloWatt (kW)	× 0.948	= Btu/s	× 1.055	= kW
Watt (W) (W=J/s)	× 0.74	= ft·lb/s	× 1.36	= W
Energy (J = N·m)				
kiloJoule (kJ)	× 0.948	= Btu	× 1.055	= kJ
Joule (J) (J=N·m)	× 0.239	= calorie	× 4.19	= J
Velocity and Acceleration				
meter per sec ² (m/s ²)	× 3.28	= ft/s ²	× 0.305	= m/s ²
meter per sec (m/s)	× 3.28	= ft/s	× 0.305	= m/s
kilometer per hour (km/h)	× 0.62	= mph	× 1.61	= km/h
Horse Power/Torque				
BHP × 5252 R.P.M. = TQ (lb·ft)		TQ Z R.P.M. 5252 = B.H.P.		
Temperature				
°C = (°F-32) ÷ 1.8		°F= (°C Z 1.8) + 32		
Flow Rate				
liter/min (dm ³ /min)	× 0.264	= US gal/min	× 3.785	= l/min

Note : () Non-SI Unit

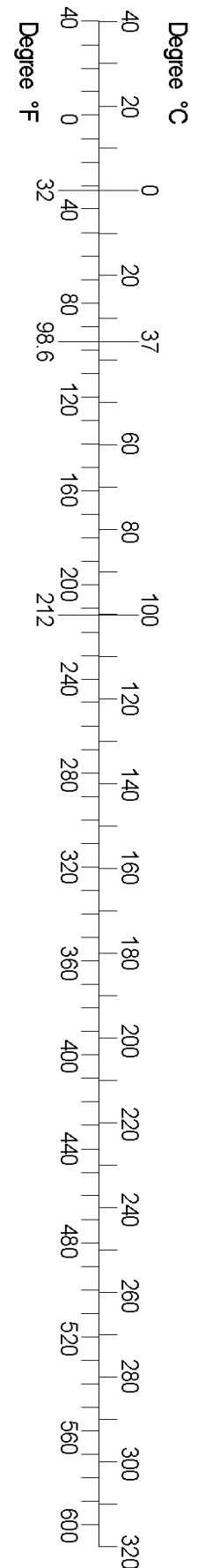

2. SPECIFICATION

2.1 LOCATION OF COMPONENTS

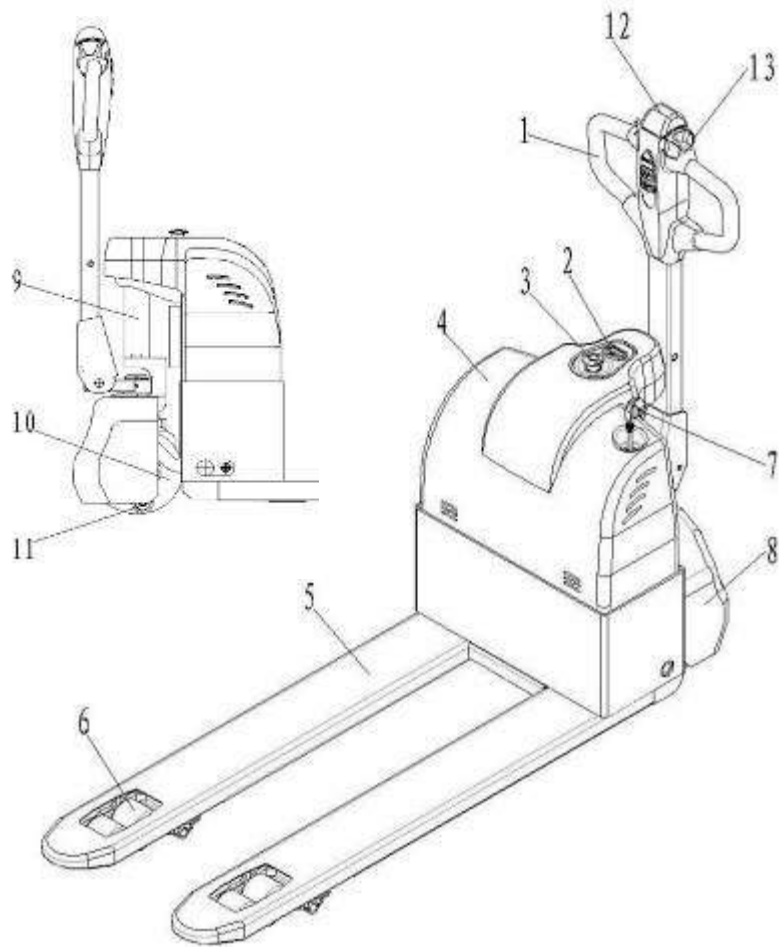

1.	Multifunction tiller	8.	Drive motor cover
2.	Discharge indicator and charging indicating LED	9.	Lift Cylinder
3.	Emergency Button	10.	Drive wheel
4.	Main cover	11.	Castors
5.	Fork chassis	12.	Safety (belly) button
6.	Load Wheels	13.	Drive control switch
7.	Charging cable		

CONTROL HANDLE

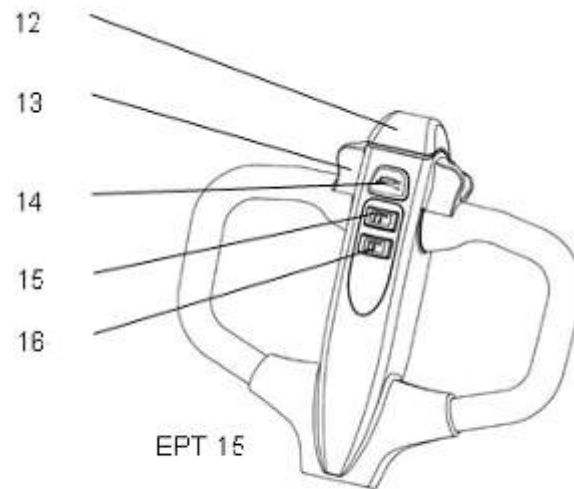

12	Safety (belly) button	15	Lifting button
13	Drive control switch	16	Lowing button
14	Horn button		

2.2 SPECIFICATION SHEET

2.2.1 Technical Features

Type sheet for industrial truck acc. to VDI 2198				
Distinguishing mark	1.2	Manufacturer`s type designation		EPT15
	1.3	Drive		electric
	1.4	Operator type		pedestrian
	1.5	Load Capacity / rated load	Q (t)	1.5
	1.6	Load centre distance	c (mm)	600
	1.8	Load distance ,centre of drive axle to fork	x (mm)	946
	1.9	Wheelbase	y (mm)	1293
Weight	2.1	Service weight	kg	190 200
	2.2	Axle loading, laden front/rear	kg	510/1180 560/1140
	2.3	Axle loading, unladen front/rear	kg	150/40 160/40
Tyres, chassis	3.1	Tires		Polyurethane (PU)
	3.2	Tire size,front	∅ x w (mm)	∅ 220x70
	3.3	Tire size,rear	∅ x w (mm)	∅ 80x70 ∅ 80x93
	3.4	Additional wheels(dimensions)	∅ x w (mm)	∅50x30
	3.5	Wheels,number front/rear(x=driven wheels)		1x +2/ 4 1x +2/ 2
	3.6	Tread, front	b ₁₀ (mm)	340
	3.7	Tread, rear	b ₁₁ (mm)	380
Dimensions	4.4	Lift	h ₃ (mm)	115
	4.9	Height of tiller in drive position min./ max.	h ₁₄ (mm)	800 / 1170
	4.15	Height, lowered	h ₁₃ (mm)	85 80
	4.19	Overall length	l ₁ (mm)	1648 1718
	4.20	Length to face of forks	l ₂ (mm)	498
	4.21	Overall width	b ₁ (mm)	560 705
	4.22	Fork dimensions	s/e/l (mm)	48/160/1150 48/160/1200
	4.25	Distance between fork- arms	b ₅ (mm)	540 685
	4.32	Ground clearance, centre of wheelbase	m ₂ (mm)	37 32
	4.34	Aisle width for pallets 800X1200 lengthways	Ast (mm)	1950
	4.35	Turning radius	Wa (mm)	1445
Performance data	5.1	Travel speed, laden/ unladen	km/h	4.2 / 4.6
	5.2	Lift speed, laden/ unladen	mm/s	30 / 53
	5.3	Lowering speed, laden/ unladen	mm/s	49 / 36
	5.8	Max. gradeability, laden/ unladen	%	4 / 10
	5.10	Service brake		electromagnetic
Electric- engine	6.1	Drive motor rating S2 60min	kW	0.45
	6.2	Lift motor rating at S3 10%	kW	0.8
	6.3	Battery acc. to DIN 43531/ 35/ 36 A, B, C, no		no
	6.4	Battery voltage, nominal capacity K5	V/ Ah	2x12V / 64
	6.5	Battery weight	kg	48 kg
	6.6	Energy consumption acc. to VDI cycle	kWh/h	0,39
Other	8.1	Type of drive control		MOSFET Control
	8.4	Sound level at driver`s ear acc. to EN 12053	dB(A)	69

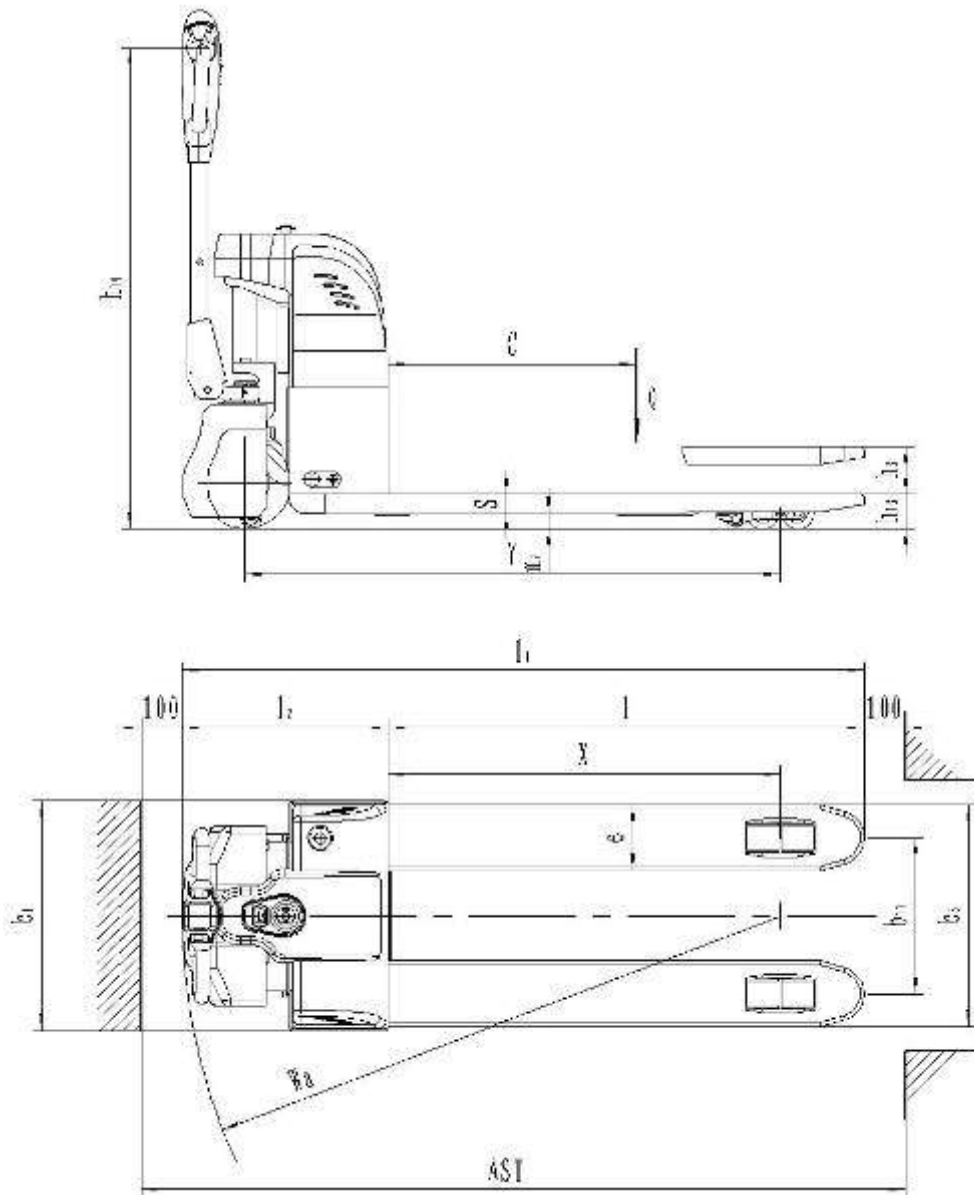

2.3 LUBRICATION

Hydraulic oil

⚠ CAUTION Hydraulic oil must have anti-wear qualities at least. It is not advisable to mix oils of different brands or types, as they may not contain the same required additives or be of comparable viscosities.

Name: Thickened hydraulic oil.

ISO Viscosity Grade		#40	#30
Characteristics	unit		
Viscosity	At 40°C	57	48
	At 50°C	40	30
Viscosity index		≥ 150	≥ 150
Flash point, Cleveland open cup	°C	≥ 160	≥ 160
Pour point, Max	°C	≤ -35	≤ -35
Density at 15 °C	kg/m ³		861.5
Copper corrosion(100°C, 3h)	degree	≤ 1	≤ 1
Foaming (93.5 °C)	ml / ml	≤ 30/0	≤ 30/0
Vickers vane pump test, loss of mass (on vanes after 100h)	mg	≤ 100	15.3
Diameter of wear spot, 1200 r/min, 294N, 30min, 75 °C	mm	≤ 0.5	≤ 0.5

The oil for gear box

Name: Extreme pressure lithium-based grease, 1#.

Characteristics	unit	
Worked Penetration, 0.1mm		310--340
Dropping point,	°C	≥ 170
Extreme pressure (Timken OK)	N	≥ 177
Similar viscosity (-10 °C, 10s ⁻¹)	Pa. s	≤ 250
Corrosion preventive properties (52 °C, 48h)	Grade	1
Wire points oil (100 °C, 24h)	%	≤ 10

3 ELECTRIC SYSTEM

3.1 ELECTRIC DIAGRAM

WIRING DIAGRAM

Electric diagram EPT 15

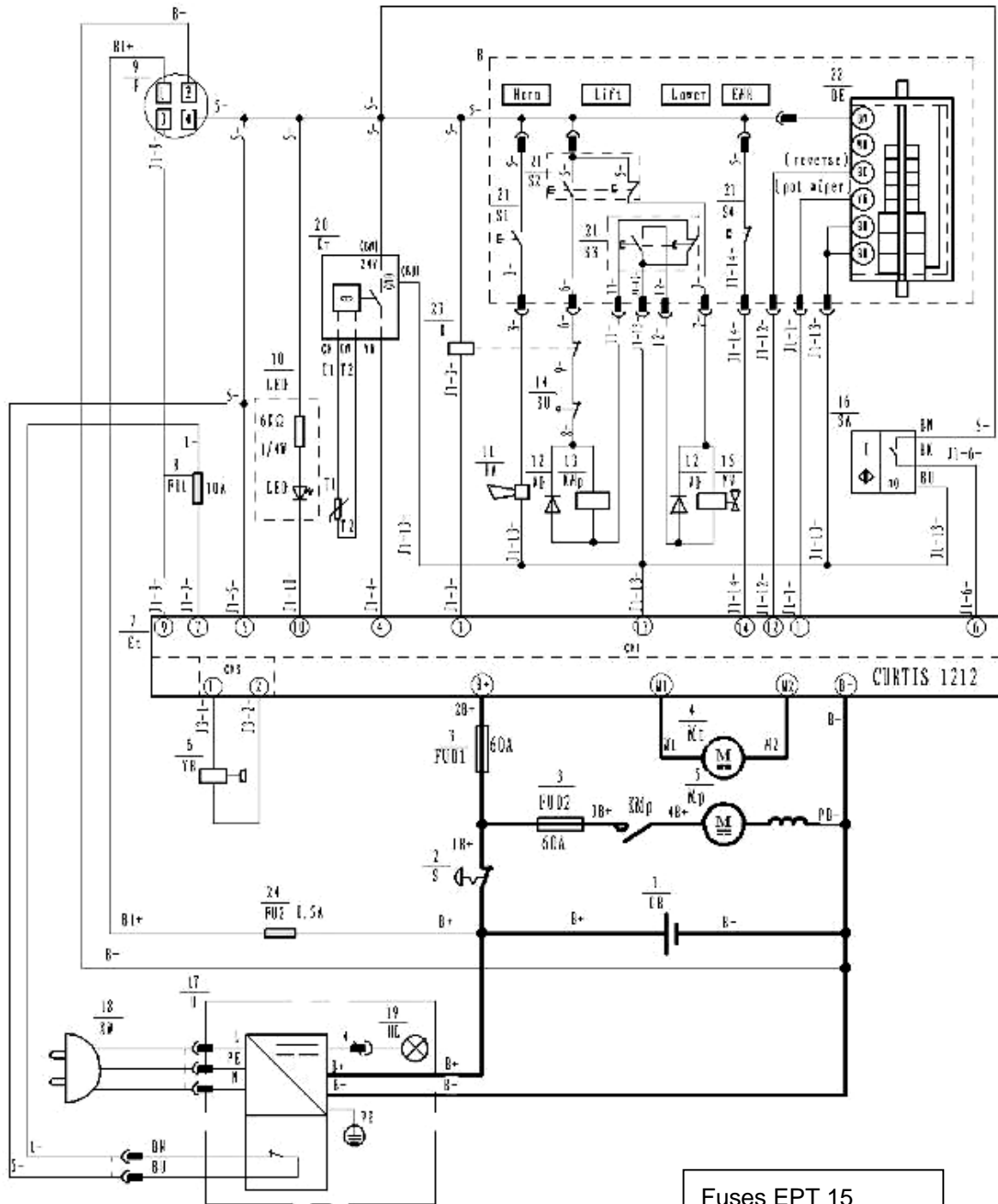

Fuses EPT 15	
FU1	: 10A
FU2	: 0.5A
FU01	: 60A
FU02	: 60A

No.	Code	Description	Qty.
1	GB	Battery, 12V/64Ah	2
2	S	Emergency button ,S100/80	1
3	FU01,FU02	Fuse, 60A	2
4	Mt	Motor for traction, DC24V	1
5	Mp	Motor for lift, DC24V	1
6	YB	Brake, DC24V	1
7	Et	Controller, Curtis 1212-2501	1
8	FU1	Fuse,10A	1
9	P	Battery Indicator, CURTIS 906 T24BNBO	1
10	LED	Trouble light	1
11	HA	Buzzer, HYD-4216W 24VDC	1
12	VD	diode,1N5408	2
13	KMp	Contactora for lift	1
14	SU	Micro switch ,WS1-Z5-W200R200	1
15	YV	Valve, DC24V	1
16	SA	Inductive Sensor, NBN5-FT-E2	1
17	U	Charger, 24V/8A	1
18	XW	Power cord	1
19	HL	Charging indicator	1
20	Kr	Protect module ,BD-W-115	1
21	S1,S2,S3,S4	Micro switch ,SS-5GL2	4
22	BE	Accelerator, BD-126	1
23	K	Relay,ARP12F-1C 24VDC	1
24	FU2	Fuse, 0.5A	1

CONNECTION DIAGRAM

EPT

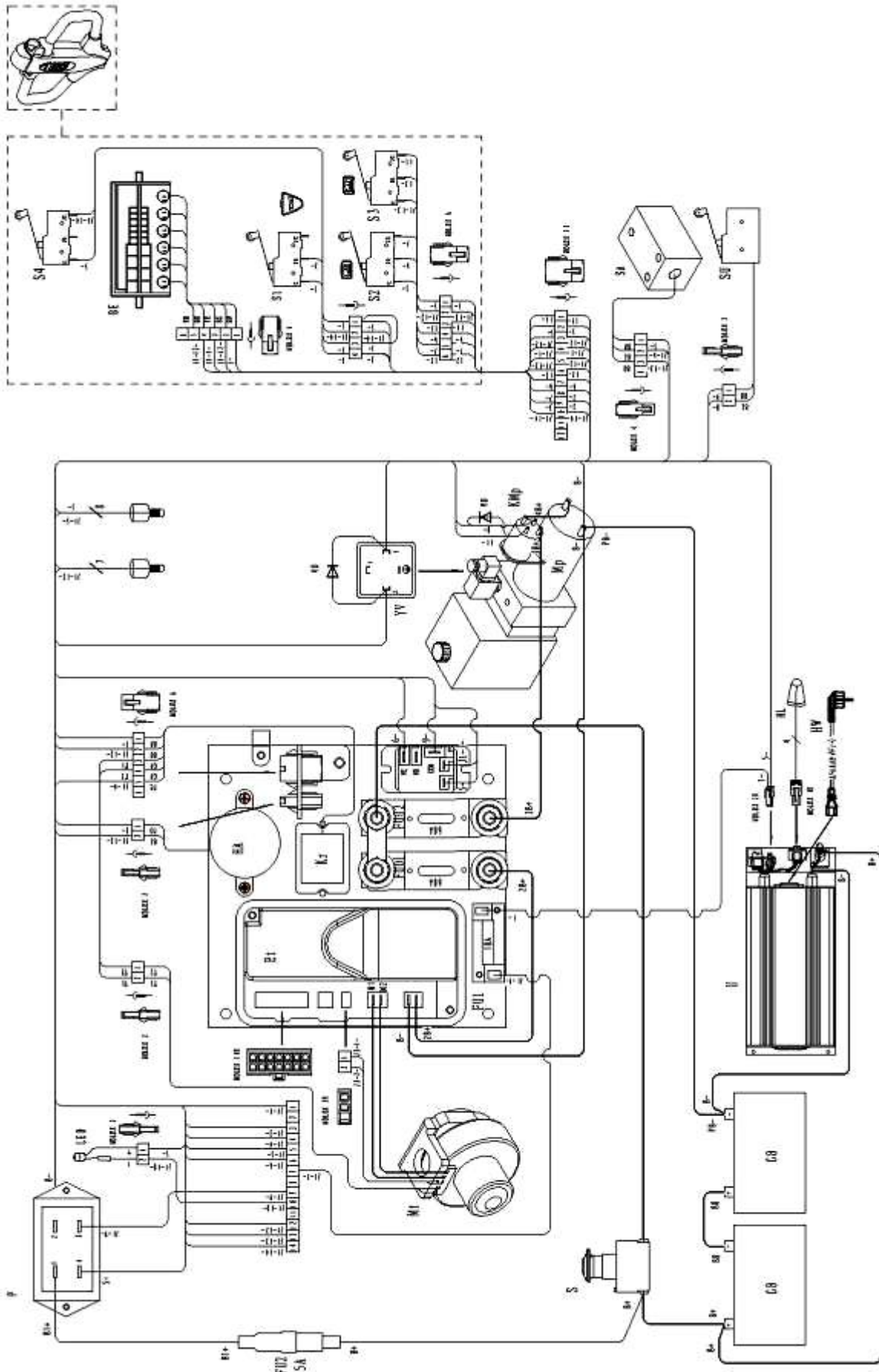

CABLE SYSTEM

5

EPT

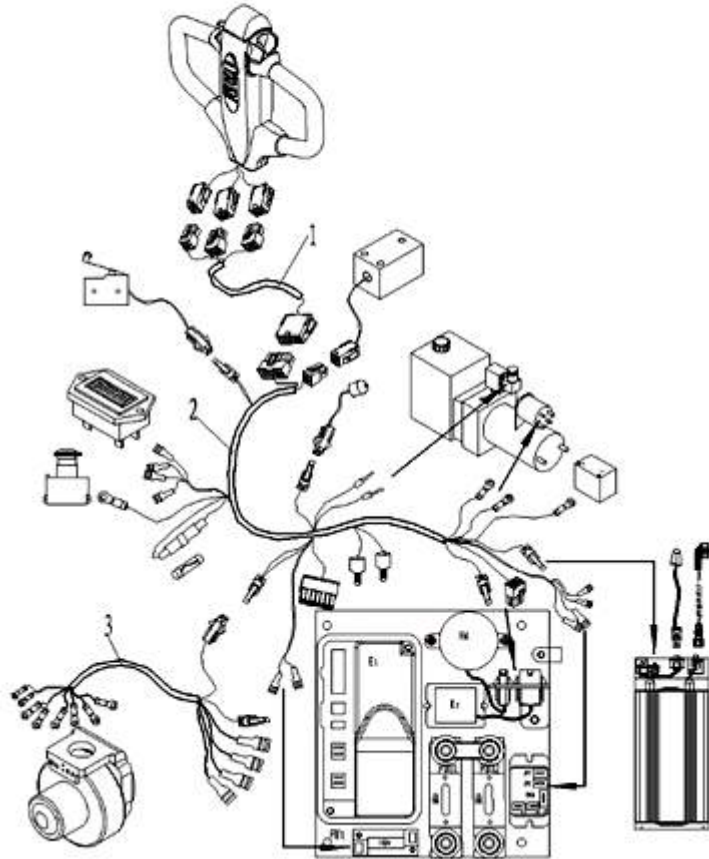

No.	Description	Qty.
1	Handle control cable	1
2	Control cable	1
3	Drive motor power cable	1

3.2 ELECTRICAL INSTALLATION

EPT

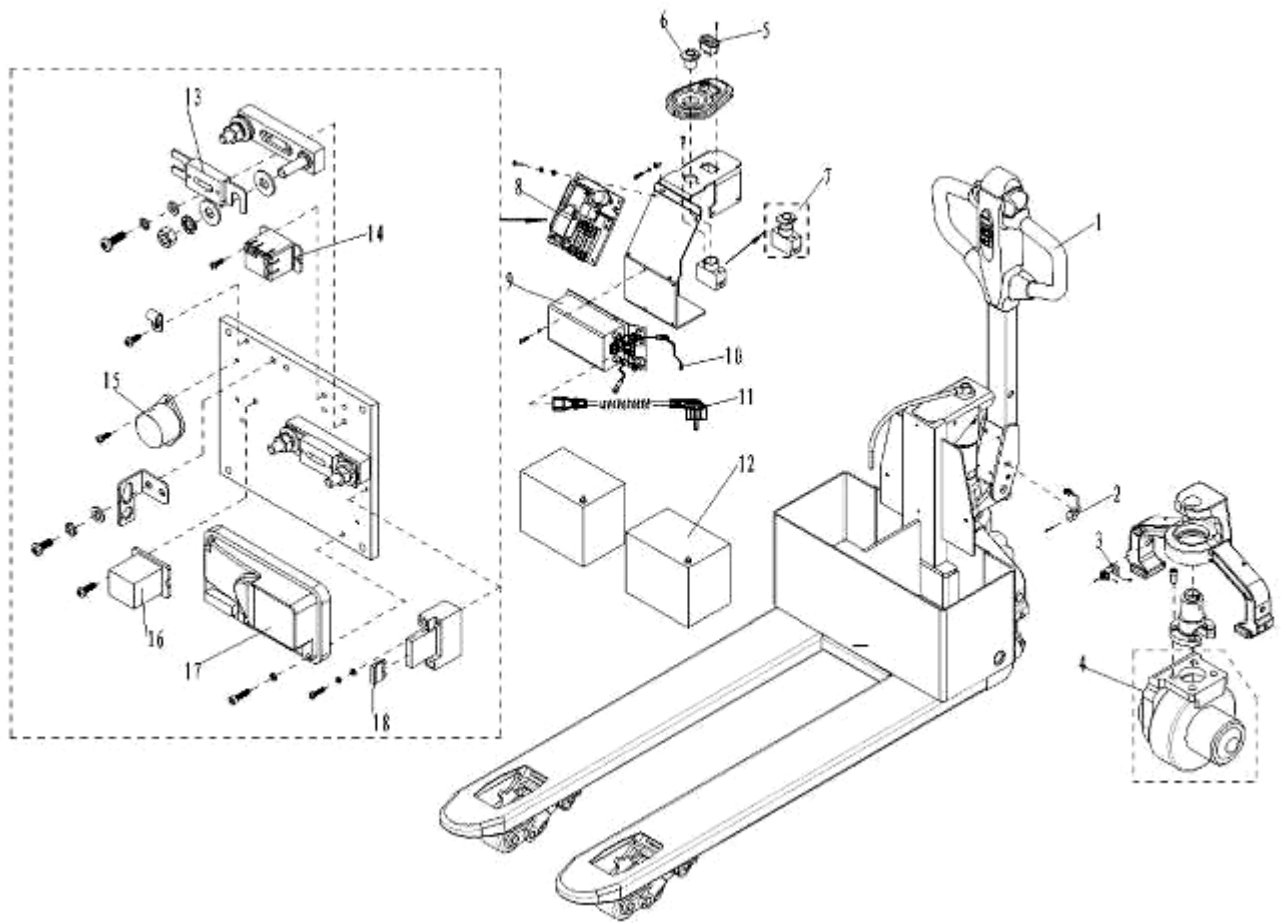

1.	Handle	7.	Emergency button ,S100/80	13.	Fuse, 60A
2.	Inductive sensor, NBN5-FT-E2	8.	Electrical installation board	14.	Relay,ARP12F-1C 24VDC
3.	Micro switch , WS1-Z5-W200R200	9.	Charger, 24V/8A	15.	Buzzer, HYD-4216W 24VDC
4.	Motor for traction	10.	Charging indicator	16.	Protection module ,BD-W-115
5.	Battery indicator, CURTIS 906 T24BNBO	11.	Power cord	17.	Controller, Curtis 1212-2501
6.	Key switch	12.	Battery, 12V/64Ah	18.	Fuse, 10A

3.3 DRIVE WHEEL

Type: 19EL-DC-0.45kw

Drive Motor	
Model	ZD11265-650W24V
Rate voltage	DC 24V
R.P.M	2650rpm
Rate output	0.45kw
Rate hour	60 min.
Rated current	36 A
Insulation class	F class
Electromagnetic Brake	
Model	REB-05-06
Rate voltage	DC 24V
Output Torque	6N.M
Gear Box	
transmission ratio	1:28

3.4 PUMP STATION

Type: CMB3-VB1111131-030

Item	EPT15
Rated voltage	24V
Rated output	0.8kw
R.P.M	4200 rpm
Rated current	60 A
Rated hour	1.8 min.
Insulation class	F class
IP Code	IP54
Displacement	1.0cc/rec
Max. operating pressure	130bar

3.5 BATTERY

The size of battery is according to English BS standard.

Rate	Specification
	EPT15
Rated voltage	12V (X2)
Capacity (5 hours)	60Ah
Overall size (L*W*H)(mm)	260×172×215

20A DURATION OF DISCHARGING CURVE (ENVIRONMENTAL TEMPERATURE = 25°C)

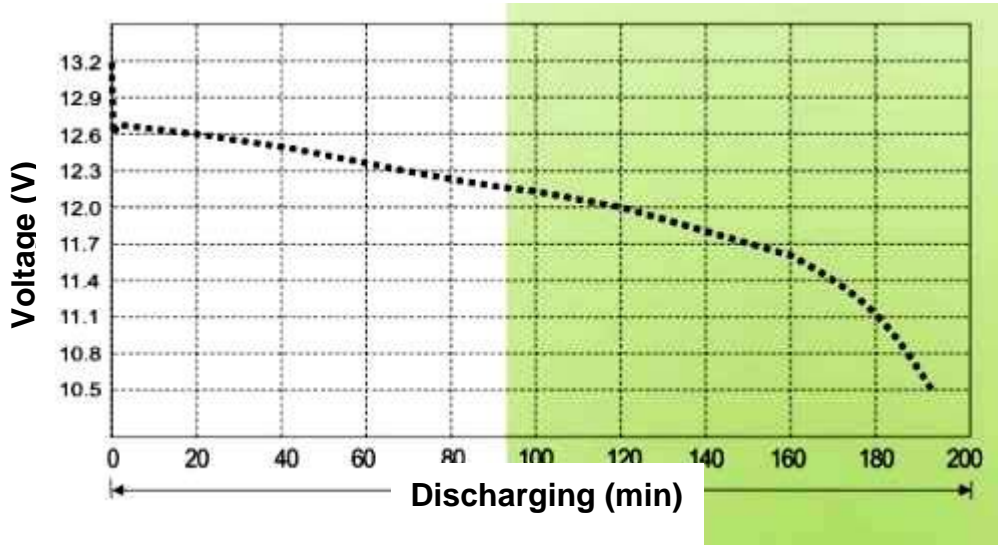

100% DURATION OF DISCHARGING LIFE TEST CURVE (ENVIRONMENTAL TEMPERATURE = 25 °C)

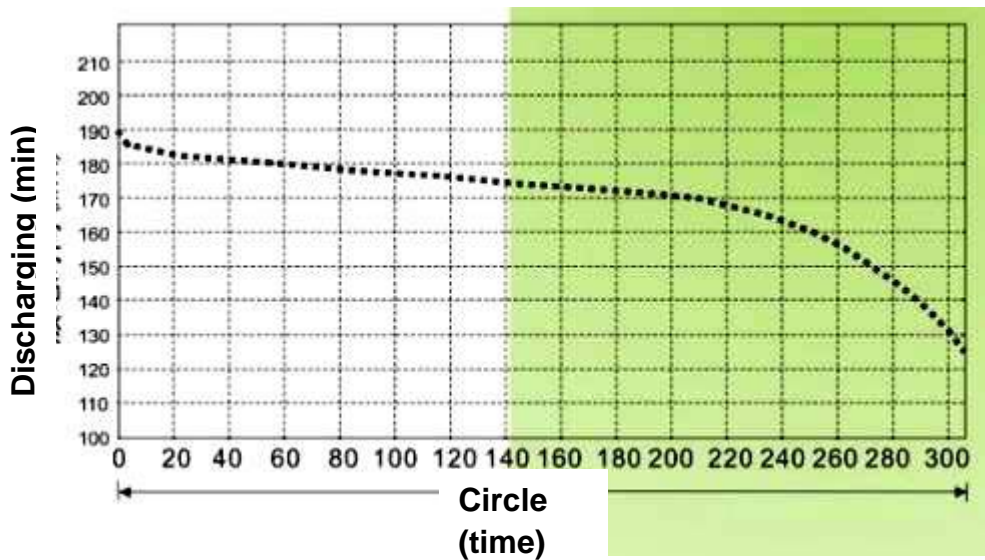

CHARGING CURVE

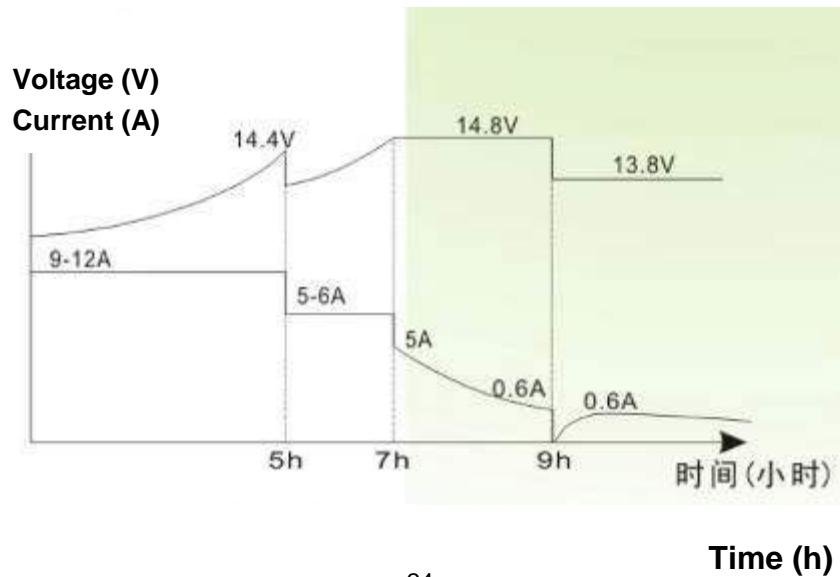

3.6 CHARGER

Type: QQE192-8CH17-26B for EPT

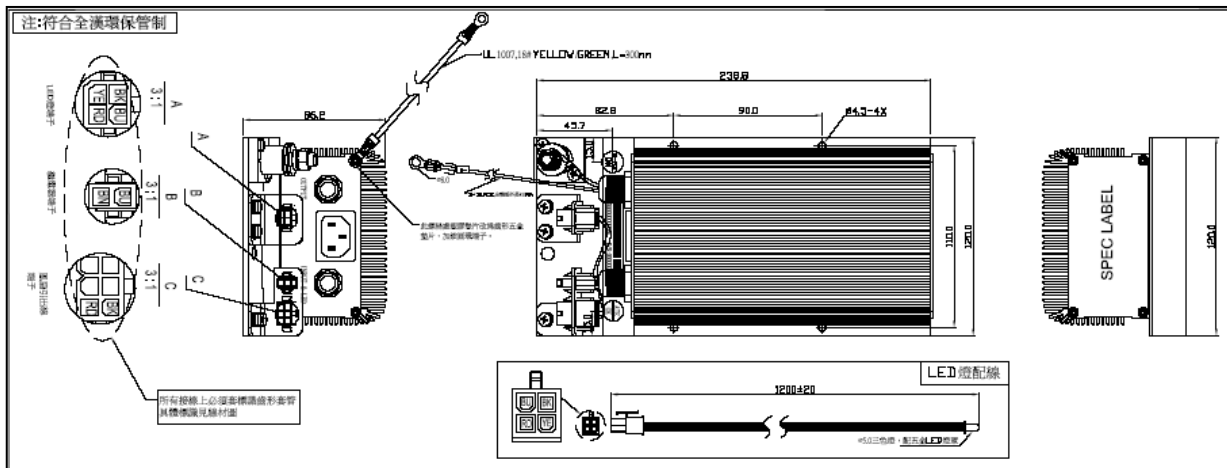

MAIN PRODUCT SPECIFICATION

Max. output power	battery capacity	Input voltage	Output voltage	Output current range
240W	40AH-100AH	230Vac	+28.2Vdc	8A
150W	25AH-60AH	115/230Vac	+29.4Vdc	5A

ENVIRONMENTAL CONDITION

No.	Item	Technical specification	Unit	Remark
1	Humidity	5%-95%		With package
2	Altitude	≅ 3000	m	Work normally
3	Cooling	Natural convection cooling		Working under full load

ELECTRICAL CHARACTERISTICS

1 Input characteristics				
No.	Item	Technical specification	Unit	Remark
1.1	Rated input voltage	230	Vac	230Vac
1.2	Input voltage range	180-264	Vac	
1.3	AC input voltage frequency	47—63	Hz	
1.4	Inrush current	≤100	A	264Vac input / start-up in cold condition /environmental temperature is 25℃
1.5	Max input current	3.0	A	Vin=180Vac, rated load
1.6	Fan function	When input is on,voltage for fan is 12V When input voltage is off,there is no output voltage for fan		
1.7	Relay function	When input voltage is on, Relay output wire BN and BU are disconnected. When input voltage is off, Relay output wire BN and BU are connected.		
2 Output characteristics				
No.	Item	Technical requirements	Unit	Remark
2.1	Fast charge voltage	28.2	Vdc	
2.2	Floating voltage	31	Vdc	
2.3	Maintain voltage	27.6	Vdc	
2.4	Constant current	8	A	
2.5	Cross regulation	±3%		
2.6	Power efficiency	≥88%		Vin=230Vac,rated load
3 Protection characteristics				
No.	Item	Technical requirements	Unit	Remark
3.1	Output over voltage protection	33	V	Lockout
3.2	Software over voltage protection	The charger software limits the maximum output voltage to a level suitable for the connected battery system		
3.3	Thermal cutback	When the internal temperature rises to 85℃, it turns into pulse charge mode. The pulse mode charges battery minutely with alternate currents 2A and 8A, which will reduce charger internal temperature. When the internal temperature drops to 60℃, the charger comes back to previous charge mode.		
3.4	Output current limiting protection	8	A	@CC MODE
3.5	Output short circuit protection	Short circuit protection should be automatically recovery after remove the condition		
3.6	Electronic reverse battery protection	The charger is electronically protected against permanent revers battery connection		
3.7	Cell short circuit timer	Internal software protection		
4 Charger(LED) indicator				
No.	Item	Status LED	Remark	
1	Power on	LED (GREEN) ON		
2	Power off	LED OFF		
3	Fast Charge	LED (RED) ON		
4	Floating Charge	LED (ORANGE) ON		
5	Full Charging	LED (GREEN) ON		

INPUT TERMINAL DIAGRAM & DEFINITION

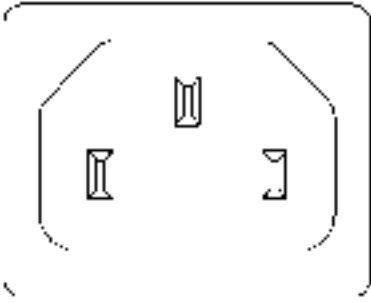

OUTPUT TERMINAL DIAGRAM & DEFINITION

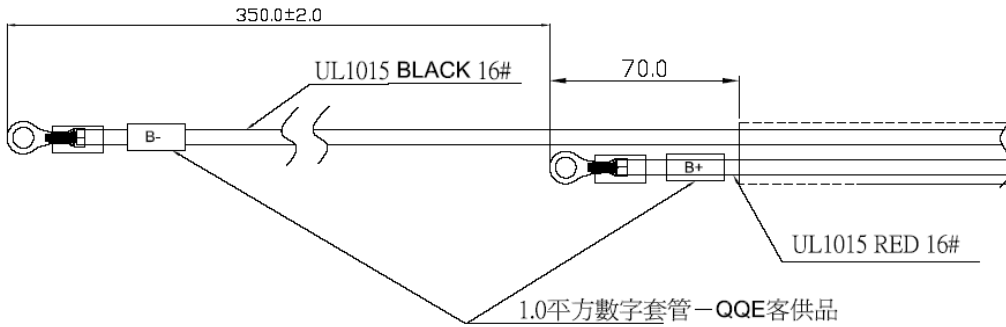

LED CONNECTOR DIAGRAM & DEFINITION

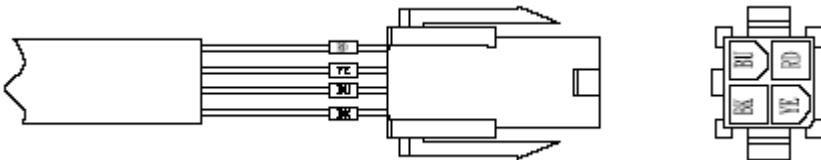

FAN CONNECTOR DIAGRAM&DEFINITION

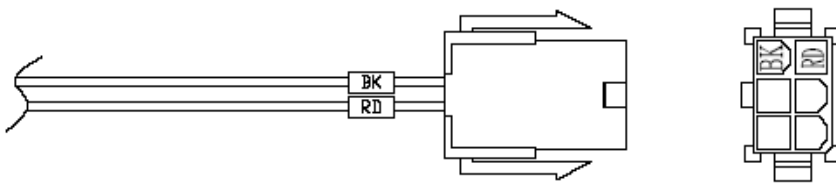

RELAY CONNECTOR DIAGRAM & DEFINITION

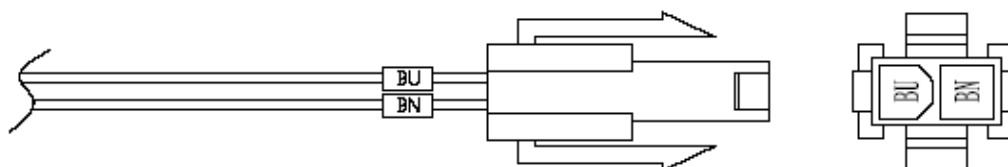

3.7 CURTIS CONTROLLER 1212

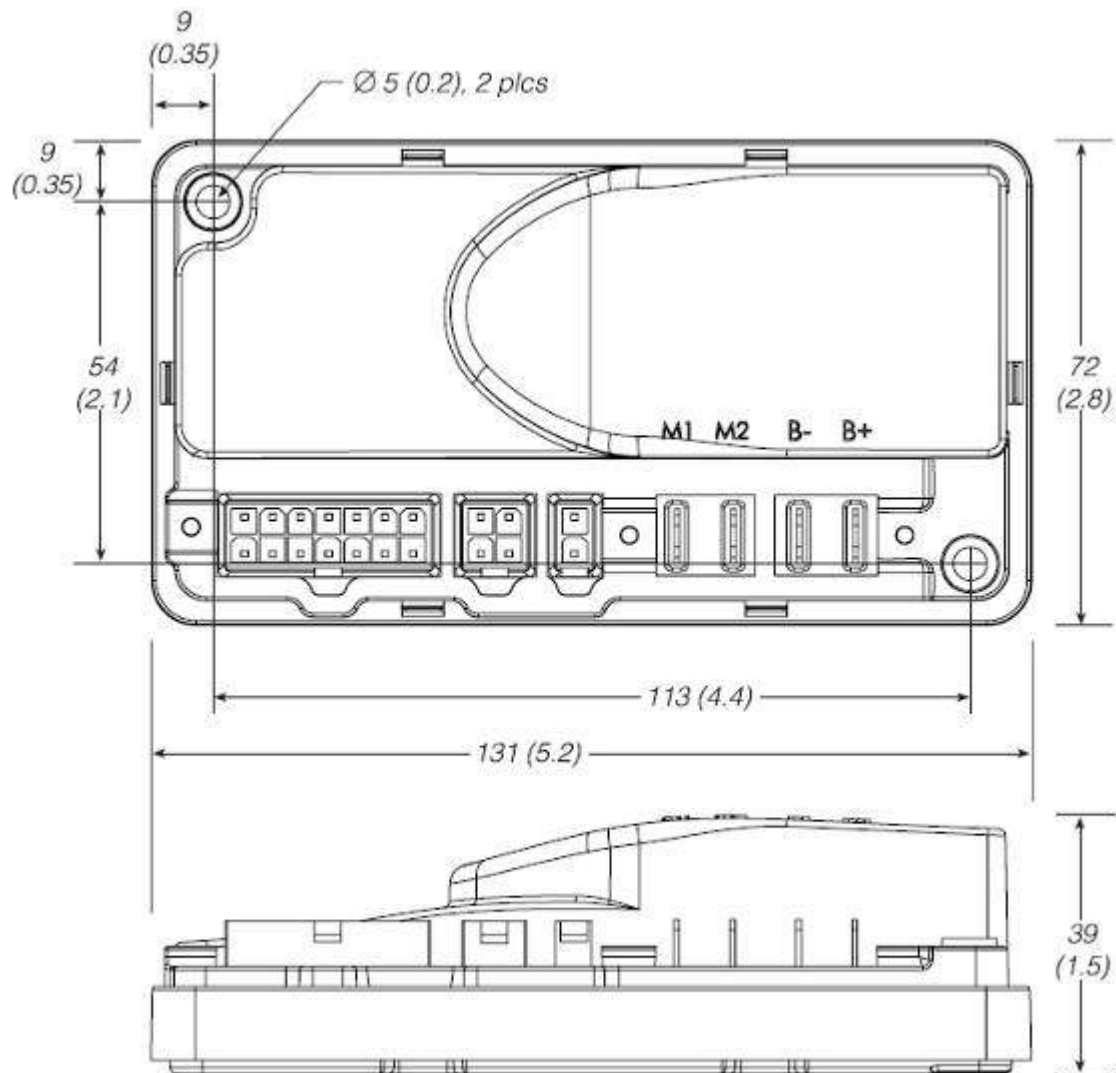

Dimensions in millimeters and (inches)

CONNECTIONS

Low Current Connections

A 14-pin Molex low current connector in the controller provides the low current logic control connections:

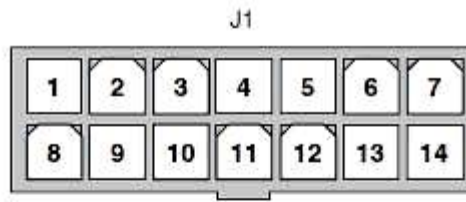

J1 Pin 1	pot wiper
J1 Pin 2	pot high
J1 Pin 3	horn switch
J1 Pin 4	mode switch (open=M1, closed=M2)
J1 Pin 5	keyswitch input (KSI)
J1 Pin 6	speed inhibit
J1 Pin 7	B+
J1 Pin 8	pot low
J1 Pin 9	speed pot
J1 Pin 10	status LED
J1 Pin 11	BDI
J1 Pin 12	reverse switch
J1 Pin 13	B-
J1 Pin 14	push switch

The mating connector is a Molex Mini-Fit Jr., receptacle p/n 39-01-2140 with appropriate 45750-series crimp terminals.

- J2 Pin 1 Rx
- J2 Pin 2 B-
- J2 Pin 3 Tx/charge inhibit
- J2 Pin 4 B+

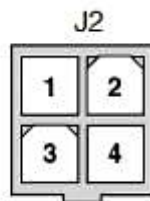

A 4-pin low power connector is provided for the programmer and the battery charger. The mating connector is a Molex Mini-Fit-Jr. p/n 39-01-2040 with appropriate 45750-series crimp terminals. (A mating connector is provided with the 1311 handheld programmer.)

- J3 Pin 1 Brake +
- J3 Pin 2 Brake -



A 2-pin low power connector is provided for the electromagnetic brake. The mating connector is a Molex Mini-Fit-Jr. receptacle p/n 39-01-2020 with appropriate 45750-series crimp terminals.

High Current Connections

Four 1/4" Faston terminals are provided for the high current connections.

The motor connections (**M1**, **M2**) and battery

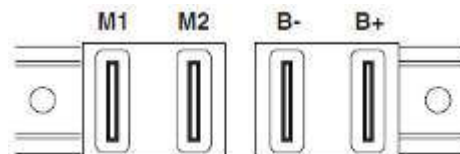

Connections (B+, B-) have one terminal each.
 STANDARD_PARAMETER

Parameter Software	standard parameter	RANGE	Unit	DESCRIPTION
Drive menu				
Accel Max Speed	1.8	0.2 to 5.0	seconds	Sets the rate (in seconds) at which the speed command increases when throttle is applied with the speed limit pot is in its maximum speed position, and the vehicle is traveling forward. Larger values represent slower response.
Accel Min Speed	5.0	1.8 to 8.0	seconds	Sets the rate (in seconds) at which the speed command increases when throttle is applied while the speed limit pot is in its minimum speed position, and the vehicle is traveling forward. Larger values represent slower response.
Decel High Speed	0.6	0.2 to 1.5	seconds	Sets the rate (in seconds) that is used to slow down the vehicle when it is traveling forward at high speed and throttle is reduced. Larger values represent slower response.
Decel Low Speed	1.5	0.6 to 8.0	seconds	Sets the rate (in seconds) that is used to slow down the vehicle when it is traveling forward at low speed and throttle is reduced. Larger values represent slower response.
Rev Accel Max Speed	1.8	0.2 to 5.0	seconds	Sets the rate (in seconds) at which the speed command increases when throttle is applied while the speed limit pot is in its maximum speed position, and the vehicle is traveling in reverse. Larger values represent slower response.
Rev Accel Min Speed	5.0	1.8 to 8.0	seconds	Sets the rate (in seconds) at which the speed command increases when throttle is applied while the speed limit pot is in its minimum speed position, and the vehicle is traveling in reverse. Larger values represent slower response.
Rev Decel High Speed	0.6	0.2 to 1.0	seconds	Sets the rate (in seconds) that is used to slow down the vehicle when it is traveling in reverse at high speed and throttle is reduced. Larger values represent slower response.
Rev Decel Low Speed	1.0	0.6 to 8.0	seconds	Sets the rate (in seconds) that is used to slow down the vehicle when it is traveling in reverse at low speed and throttle is reduced. Larger values represent slower response.
Keyoff Decel	0.7	0.2 to 4.0	seconds	Sets the rate (in seconds) that is used to slow down the vehicle when it is traveling in reverse at low speed and throttle is reduced. Larger values represent slower response.

E Stop Decel	0.6	0.2 to 4.0	seconds	Sets the rate (in seconds) that is used to slow down the vehicle during emergency reverse, i.e., when a throttle command >80% in the reverse direction is given while the vehicle is moving forward. This gives the operator a way to stop more quickly when unexpected conditions arise.
E Stop Pause	0.5	0.0 to 1.0	seconds	Sets a pause before reversing direction after an emergency reverse stop. This gives the operator time to return the throttle to neutral without moving backwards.
Soft Start	25	0 to 100	%	This parameter can be used to soften the bump associated with gear slack in the transaxle when throttle is applied from the neutral state. Larger values provide a softer slack take-up.
Gear Soften	15	0 to 100	%	This parameter is intended to soften the bump associated with gear slack in the transaxle when throttle is released and then reapplied while the vehicle is still moving. Larger values provide a softer slack take-up.
Creep Speed	7	0 to 10	%	Creep Speed helps to prevent vehicle rollback on inclines when the brake is released with very little throttle applied. It is activated when the throttle request exceeds the throttle deadband threshold.
Soft Stop Speed	13	0 to 30	%	Sets the speed at which a gentler deceleration is initiated when the throttle is released to neutral; larger values start the soft stop deceleration sooner.
Speed menu				
M1 Max Speed	100	20 to 100	%	During forward operation, defines the requested speed at full throttle when the speed limit pot is in its maximum speed position.
M1 Min Speed	20	0 to 100	%	During forward operation, defines the requested speed command at full throttle when the speed limit pot is in its minimum speed position. Min Speed cannot be set higher than the programmed Max Speed
M1 Rev Max Speed	100	10 to 100	%	During reverse operation, defines the requested speed at full throttle when the speed limit pot is in its maximum speed position.
M1 Rev Min Speed	10	0 to 100	%	During reverse operation, defines the requested speed command at full throttle when the speed limit pot is in its minimum speed position. Rev Min Speed cannot be set higher than the programmed Rev Max Speed.
M2 Max Speed	50	20 to 100	%	During forward operation, defines the requested speed at full throttle when the speed limit pot is in its maximum speed position.
M2 Min Speed	20	0 to 100	%	During forward operation, defines the requested speed command at full throttle when the speed limit pot is in its minimum speed position. Min Speed cannot be set higher than the programmed Max Speed
M2 Rev Max Speed	50	10 to 100	%	During reverse operation, defines the requested speed at full throttle when the speed limit pot is in its maximum speed position.
M2 Rev Min Speed	10	0 to 60	%	During reverse operation, defines the requested speed command at full throttle when the speed limit pot is in its minimum speed position. Rev Min Speed cannot be set higher than the programmed Rev Max Speed.

Throttle menu				
Type	7	0 to 9		<p>The 1212 controller can accept inputs from both 5kΩ, 3-wire pot throttles and voltage throttles. Set the throttle type parameter to match the throttle used in your application.</p> <p>5kΩ, 3-wire pot throttles</p> <p>0 = wigwag</p> <p>1 = inverted wigwag</p> <p>2 = single-ended; neutral when wiper at PotLow</p> <p>3 = inverted single-ended; neutral when wiper at PotHigh</p> <p>4 = unipolar.</p> <p>Voltage throttles</p> <p>5 = wigwag</p> <p>6 = inverted wigwag</p> <p>7 = single-ended; neutral when wiper \leq PotLow</p> <p>8 = inverted single-ended voltage; neutral when wiper \geq PotHigh</p> <p>9 = unipolar</p>
PotHigh	5.0	3.0 to 5.0	volt	Sets the maximum voltage for voltage throttles (Types 5–9). (For 5k Ω , 3-wire pot throttles, PotHigh is determined by the throttle itself.)
PotLow	0.0	0.0 to 2.0	volt	Sets the minimum voltage for voltage throttles (Types 5–9). (For 5k Ω , 3-wire pot throttles, PotLow is determined by the throttle itself.)
Neutral Deadband	5	5 to 30	%	Sets the throttle range the controller interprets as neutral. Increasing the parameter setting increases the neutral range. This parameter allows the neutral deadband to be defined wide enough to ensure the controller goes into neutral when the throttle is released.
Throttle Max	85	40 to 100	%	Sets the pot wiper voltage required to produce 100% controller output. Increasing the Throttle Max setting reduces the wiper voltage required, and therefore reduces the stroke necessary to produce full output. This feature allows reduced-range throttle assemblies to be used.
HPD	1	0 or 1		When programmed On, vehicle drive is inhibited if a throttle command outside the neutral deadband is issued before the controller is powered up. Drive will continue to be inhibited until the throttle is returned to within the neutral deadband. If the HPD fault is not cleared within 10 seconds,
Speed Limit Pot	0	0 or 1		This parameter is used to enable/disable the speed limit pot. If no speed limit pot is used, set Speed Limit Pot to Off.
Throttle Map	30	20 to 80	%	The throttle map parameter adjusts the static throttle map.
Tremor Suppression	50	0 to 100	%	This parameter can be used to limit the controller's response to sharp throttle movements, such as movements resulting from hand tremors.
Calibration	0	0 or 1		Wigwag and unipolar throttle pots should be centered. Setting this parameter to On inhibits driving and puts the controller into throttle autocalibration mode
Current menu				

Main Current Limit	90	15 to 90	Ampere	Sets the maximum current the controller will supply to the motor during 15–90 A normal driving. By limiting the current supplied, this parameter can be used to protect the motor from potentially damaging currents or to reduce the maximum torque applied to the drive system.
Braking Current Limit	90	15 to 90	Ampere	Sets the maximum current the controller will supply to the motor during braking. By limiting the current supplied, this parameter can be used to protect the motor from potentially damaging currents or to reduce the maximum braking torque applied to the drive system.
Boost Current	90	90 to 90	Ampere	The Boost Current parameter defines the motor current limit during the boost period.
Boost Time	3	0 to 10	Seconds	This parameter sets the maximum time that the boost current is allowed.
Inhibit menu				
Type	2	0 to 5		The flexible speed input at J1 Pin 6 can be used to limit or to inhibit speed under certain conditions. For example, a switch could be installed under the seat so that if the operator drives the scooter while they are standing the max speed will be limited. The Inhibit Type parameter is used to select how the inhibit function will be implemented. Depending on how the inhibit switch is wired into the system, set this parameter to: 0 = B- active 1 = B+ active 2 = Open circuit active 3 = B- inactive 4 = B+ inactive 5 = Open circuit inactive.
Speed	0	0 to 100	%	This parameter limits the maximum speed allowed during speed inhibit mode. A setting of 0 prevents drive during inhibit mode.
Brake menu				
Delay	0.3	0.0 to 1.0	Seconds	Sets the length of delay between when zero speed is commanded and the electromagnetic brake is engaged.
Fault Check	1	0 or 1		Enables/disables the fault detection on the EM brake.
Hold Voltage	18	10 to 24	volt	A high initial voltage is applied to the brake coil when the brake is first released. After approximately 1 second, this peak voltage drops to the programmed Hold Voltage. The parameter should be set high enough to hold the brake released under all the shock and vibration conditions the vehicle will be subjected to.
Brake Light	0	0 to 1		When set to On, the horn output (J1 Pin 3) will act as a brake light driver. The brake light must be driven by a relay
Horn menu				
Reverse Beep	1	0 or 1		When programmed On, the horn will sound whenever the vehicle is being driven in reverse.
Beep Constant	0	0 or 1		Sets the reverse beep to be a constant tone (when programmed On) or a 1Hz pulse (when programmed Off).
Motor menu				

System Resistance	93	0 to 800	mOhms	Sets the system resistance (motor + brushes + wiring + connections) used for load compensation and speed estimation. Control system performance depends on this parameter being set correctly; it must be set to the actual cold motor resistance.
Resistance Auto Comp	0	0 to 1		Resistance is automatically measured under a preset low current before the brake is released. The measured motor resistance plays an important role in IR compensation.
Auto Comp Current Limit	20	5 to 50	%	Sets the current limit used for automatic resistance testing, as a percentage of the Main Current Limit (see Current menu).
Speed Scaler	27	20 to 27	volt	The Speed Scaler parameter sets the maximum voltage that can be applied to the motor. It can be used to eliminate variations in maximum speed that would otherwise result when driving with a fully charged battery vs. a partially discharged battery. If Speed Scaler is set to 23 volts, for example, the maximum vehicle speed will be the same whether the actual battery voltage is 27 volts or 23 volts or any value in between.
Current Rating	30	0 to 30	Ampere	This parameter should be set to the current rating provided by the motor manufacturer.
Max Current Time	80	0 to 80	Seconds	Sets the maximum amount of time the motor is allowed to run at the main current limit.
Cutback Gain	5	0 to 100	%	When the motor overheats, the drive current is cut back until it reaches the programmed Current Rating. The Cutback Gain determines how quickly this cutback will occur, once the programmed Max Current Time has expired.
BDI menu				
Full Voltage	24.4	20.9 to 24.9	Volt	Voltage when the battery is fully charged.
Empty Voltage	20.8	0.0 to 24.3	Volt	Voltage when the battery is fully discharged.
Full Charge Voltage	28.2	25.3 to 36.0	Volt	Voltage when a charger is connected, above which the battery is considered finished charging.
Start Charge Voltage	25.2	24.5 to 28.1	Volt	Voltage above which the battery is considered to start charging.
Reset Voltage	25.8	24.5 to 36.0	Volt	Voltage at which the BDI calculator will be reset to 100%, after the charger is disconnected and the controller is powered up.
Discharge Factor	1.6	0.1 to 10.0		Discharge rate of the battery. Larger values are for larger batteries, which discharge more slowly.
Charge Factor	2.0	0.1 to 10.0		Charge rate of the battery. Larger values are for larger batteries, which discharge more slowly.
Low BDI Level	10	0 to 100	%	Sets the battery charge level at which maximum vehicle speed will be limited in order to protect the battery from deep discharge.
Low BDI Max Speed	60	10 to 100	%	Sets the maximum allowed vehicle speed when the battery charge falls below the programmed Low BDI Level.
External lift lock	1			When programmed On, Pin J1-9 will be used to receive an external lockout enable signal, lift Lockout is controlled by external signal. When programmed Off, lift lockout is controlled by the controller(See Lift Lockout Threshold)
Liftlock Enable	1	0 or 1		When programmed On, Lift lockout protection is enabled.

Liftlock Threshold	20	0 to 50	%	Sets the battery charge level at which Lift locklock protection begins
Compensation menu				
IR Comp	70	0 to 90	%	Sets the motor load compensation. Higher values provide stronger disturbance rejection, while lower values provide smoother operation.
Anti Rollback Comp	90	70 to 125	%	Sets the motor load compensation after the throttle is released to neutral and the speed is estimated to be near zero. Higher values provide more hill-holding force.
Emergency Reverse menu				
Speed	30	10 to 100	%	Defines the maximum reverse speed of the motor, when emergency reverse is active, as % PWM output
Time Limit	1.2	0.0 to 10.0	Seconds	Sets the Emergency reverse time.
Decel Rate	0.2	0.2 to 4.0	Seconds	Sets the rate at which the vehicle brakes to a stop when emergency reverse is activated and the vehicle is moving forward.
Accel Rate	0.3	0.2 to 8.0	Seconds	Sets the rate at which the vehicle accelerates in the opposite direction after it has been brought to a stop.
Max Braking Current	90	15 to 90	Ampere	Sets maximum braking current limit
Switch Normally Closed	1	0 or 1		Sets the Emergency reverse switch type, NC or NO
Misc menu				
Sleep	0	0 to 60	Minutes	Sets the delay time between the last throttle request or serial communication and when the controller goes into sleep mode. Setting the delay to zero disables the sleep function.
Fault Code Type	0	0 to 2		This parameter selects which set of fault identification codes (Type 0,1, or 2) will be flashed by the status LED; see Section 7.
Reset Drive Time	0	0 or 1		The controller's hourmeter logs the total drive time since the last reset; this record is accessible through the Monitor menu. Setting this parameter On zeroes the hourmeter and starts a new log; this is typically done when the vehicle is serviced. Reset Drive Time is automatically set to Off after the hourmeter is reset.
Emergency Stop	1	0 or 1		When programmed On, Emergency Stop is enabled.

NOTE: for “standard parameter”, 1=on, 0=off

TROUBLESHOOTING CHART

The 1212 controller provides diagnostics information to assist technicians in troubleshooting drive system problems. The diagnostics information can be obtained in two ways: by reading the appropriate display on the handheld programmer or by observing the fault codes issued by the status LED.

PROGRAMMER DIAGNOSTICS

The handheld programmer presents complete diagnostic information in plain language. Faults are displayed in the Faults menu, and the status of the controller inputs/outputs is displayed in the Monitor menu.

Additionally, the fault history file in the Faults menu provides a list of the faults that have occurred since the file was last cleared. Checking (and clearing) the fault history file is recommended each time the vehicle is brought in for maintenance.

Refer to the troubleshooting chart (Table 3) for suggestions about possible causes of the various faults. Faults are listed alphabetically.

For information on 1311 programmer operation, see Appendix C.

LED DIAGNOSTICS

During normal operation, with no faults present, the status LED is steadily on. If the controller detects a fault, the status LED flashes a fault identification code continuously until the fault is corrected.

Refer to the troubleshooting chart (Table 3) for suggestions about possible causes of the various faults. Faults are listed alphabetically.

Note: The status LED can only indicate one fault at a time. If multiple faults are detected, the highest priority fault code flashes until it is cleared.

Three sets of fault codes are available. The Fault Code Type parameter (Program » Misc » Fault Code Type) is used to select which set of fault codes will be used: Type 0, Type 1, or Type 2. The codes are listed in Tables 2-0, 2-1, and 2-2.

Table 3 TROUBLESHOOTING CHART

LED CODE TYPE			PROGRAMMER LCD DISPLAY	EXPLANATION	POSSIBLE CAUSE
0	1	2			
4,5	1	9	BATTERY DISCONNECT FAULT	battery disconnected	1. Battery not connected. 2. Poor connection to battery terminals.
3,4	8	9	BRAKE OFF FAULT	brake Off fault	1. Electromagnetic brake driver open. 2. Electromagnetic brake coil shorted.
3,2	9	5	BRAKE ON FAULT	brake On fault	1. Electromagnetic brake driver shorted. 2. Electromagnetic brake coil open.
4,1	8	9	CURRENT SENSE FAULT	current sense out of range	1. Short in motor or in motor wiring. 2. Controller failure. ★
4,3	8	9	EEPROM CHECKSUM FAULT	EEPROM fault	1. EEPROM failure or fault.
4,2	8	9	HARDWARE FAILSAFE	motor voltage out of range	1. Motor voltage does not correspond to throttle request. 2. Short in motor or in motor wiring. 3. Controller failure. ★
3,5	7	6	HPD FAULT	HPD (High Pedal Disable)	1. Improper sequence of throttle and KSI, push, or inhibit inputs. 2. Misadjusted throttle pot.
2,3	8	9	MAIN FAULT	main contactor fault	1. Main contactor welded or stuck open. 2. Main contactor driver fault.
2,1	8	9	MAIN OFF FAULT	main contactor driver Off fault	1. Main contactor driver failed open.
2,4	8	9	MAIN ON FAULT	main contactor driver On fault	1. Main contactor driver failed closed.
1,5	10	3	OVERVOLTAGE FAULT	battery voltage too high	1. Battery voltage >31 volts. 2. Vehicle operating with charger attached. 3. Intermittent battery connection.
3,3	8	9	PRECHARGE FAULT	precharge fault	1. Brake driver shorted. 2. Precharge circuit damaged. 3. MOSFET failure.
1,3	-	7	SPEED POT FAULT	speed limit pot wiper out of range	1. Speed limit pot wire(s) broken or shorted. 2. Broken speed limit pot.
1,1	-	-	THERMAL FAULT	over-/under-temperature cutback	1. Temperature >80°C or < -10°C. 2. Excessive load on vehicle. 3. Operation in extreme environments. 4. Electromagnetic brake not releasing.
1,2	7	7	THROTTLE FAULT	PotLow and/or PotWiper out of range	1. Throttle input wire open or shorted. 2. Throttle pot defective. 3. Wrong throttle type selected.
1,4	1	2	UNDERVOLTAGE FAULT	battery voltage too low	1. Battery voltage <17 volts. 2. Bad connection at battery or controller.
3,1	7	6	WIRING FAULT	HPD fault present >10 sec.	1. Misadjusted throttle. 2. Broken throttle pot or throttle mechanism.

CURTIS 1311 HANDHELD PROGRAMMER

Curtis programmers provide programming, diagnostic, and test capabilities for 1212 controllers. The power for operating the programmer is supplied by the host controller via a 4-pin connector. Two programmers are available: the PC Programming Station (1314) and the handheld programmer (1311). The Programming Station has features not available on the handheld unit; on the other hand, the handheld programmer has the advantage of being more portable. Typically the Programming Station is used to set up the parameters initially and the handheld programmer is used to make adjustments in the field.

Several versions of each programmer are available (User, Service, Dealer, OEM): the User programmers can adjust only User-access parameters, whereas the OEM programmers can adjust all the parameters.

The 1311 programmer is easy to use, with self-explanatory functions. After plugging in the programmer, wait a few seconds for it to boot up and gather information from the controller. For experimenting with settings, the programmer can be left plugged in while the vehicle is driven.

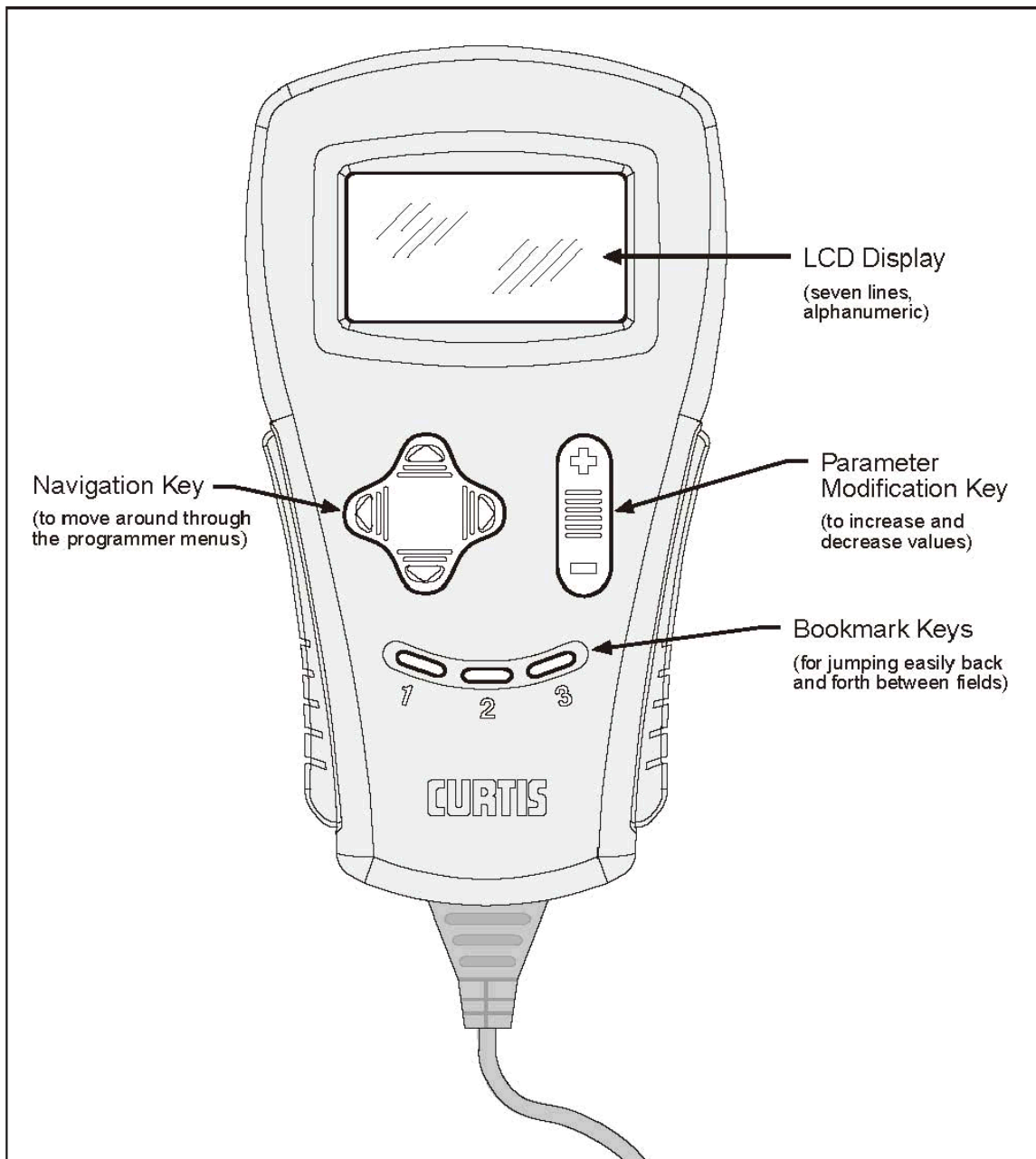

The bookmark keys allow you to quickly go back to up to three selected items without having to navigate back through the menu structure. To set a bookmark, press one of the bookmark keys for about three seconds, until the Bookmark Set screen is displayed. To jump to a set bookmark location, quickly press the appropriate bookmark key(1, 2, or 3). Note that the bookmarks are not permanently stored in the programmer. They are cleared when the programmer is unplugged.

The bookmark keys can be used to make parameter adjustment easier. For example, in adjusting the throttle dead band, you might set a bookmark at the Throttle % readout [Monitor > THROTTLE %] and another at the Throttle Dead band parameter [Program > THROTTLE DB]; this way you can easily toggle between the readout and the parameter.

3.8 BATTERY DISCHARGE INDICATOR

Type: 906



Front View

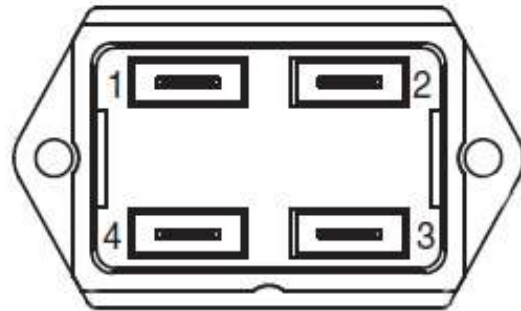

Rear View

TERMINALS

Pin 1 = Battery +

Connected to the vehicle's main positive (+) terminal.
Use as short a wire as practical.

Pin 2 = Battery -

Connects to the vehicle's main negative (-) terminal
Use as short a wire as practical.

Note: Pins 1 & 2 are connected across the total battery pack.

Pin 3 = Output Signal + or No Option

Output Signal option: 5 VDC \pm 0.5 VDC (90 μ A current source) above Empty, 0-0.1 VDC at Empty
1 VDC maximum (90 μ A sink);

No Option: Pin 3 is left open.

Pin 4 = Keyswitch

Connects to Battery + through the switched terminal of the Keyswitch.

OPERATION

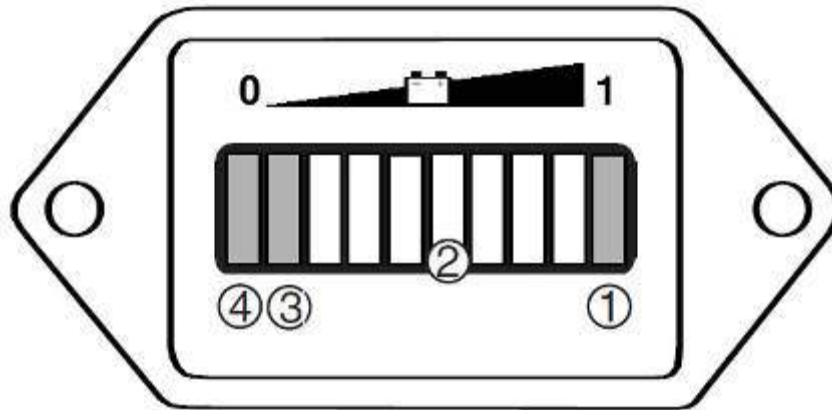

Display

- ① Only when the battery is properly charged is the right-most LED lit.
- ② As the battery's state-of-charge decreases, successive LEDs light up, only one on at a time.
- ③ The 2nd-from-left LED flashes, indicating "energy reserve" (70% depth of discharge).
- ④ The 2 left-most LEDs alternately flash, indicating "empty" (80% depth of discharge).

Reset

OCR (Open Circuit Reset)

Upon reconnection of battery, the indicator will reset at or above proper voltage level.

HVR (High Voltage Reset)

Indicator stays connected to battery during charging. Battery must remain at or above proper voltage level for a continuous 6 minutes.

TROUBLESHOOTING

Problem	Possible Cause
Keyswitch On and no display	Terminals not connected or improper voltage, Keyswitch not high
Stays at Full	Indicator voltage does not match battery voltage
Will not reset	Indicator voltage does not match battery voltage or battery not fully charged
Reset without charging battery	Not connected directly to battery terminals
Empty too soon	Indicator voltage does not match battery voltage or terminals not connected directly to battery

3.9 REPLACE THE ELECTRIC PARTS



Remove 4 pc the screws.

Then remove the main cover and the motor cover.

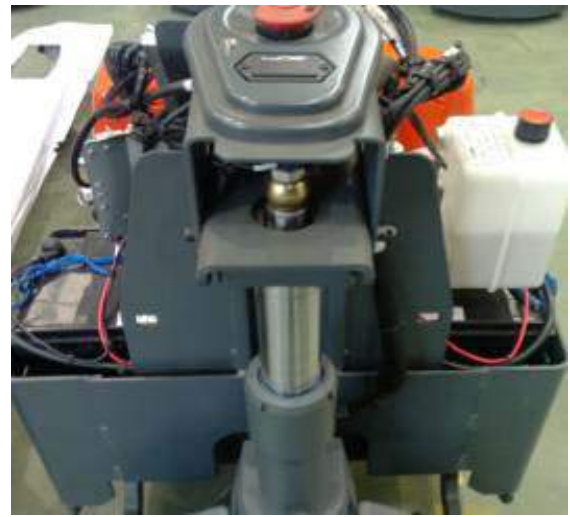

REPLACE THE CHARGER



Remove 4 screws



Remove AC input plug



Remove ground plug and positive-negative plug of output



Dismantle the wire connecting the charger and the battery, dismantle 3 pairs of connectors, Then you can dismantle the charger and replace it

REPLACE THE BATTERY

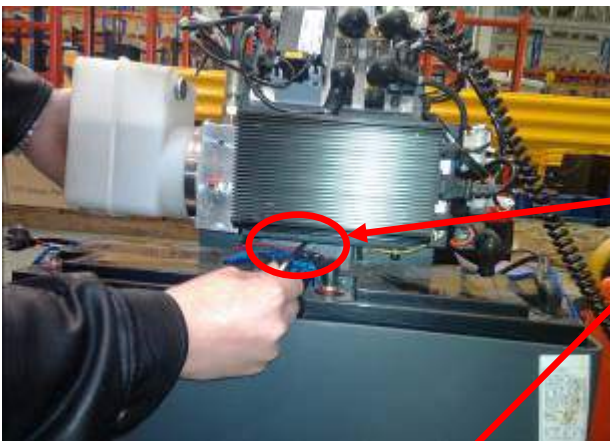

Remove M6 internal-hexagonal screws and other 2 screws, so that we can raise up the whole electronic control board for repairing.



Remove the bolts, nuts, washers, which fix the power cable (+ , -) to the battery.

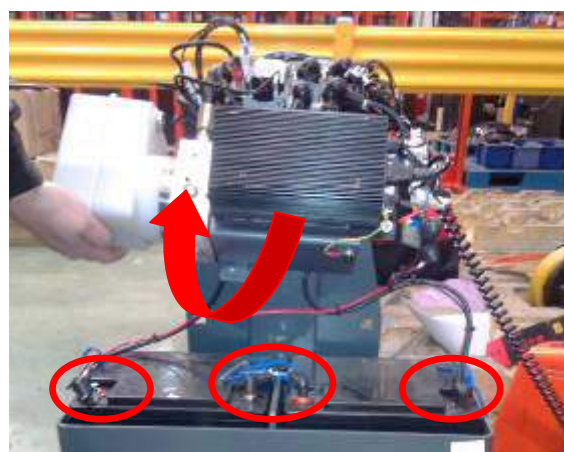

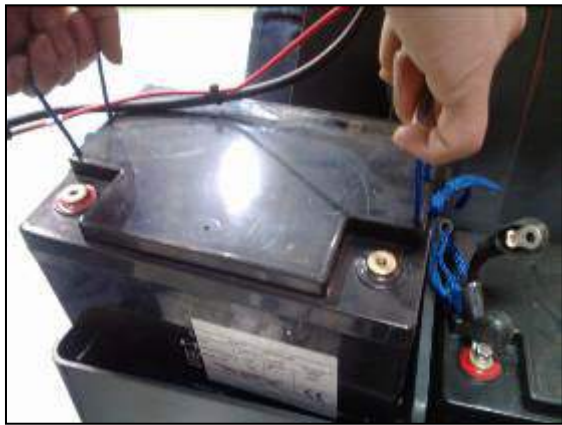

Take out the battery



After dismantle the battery

REPLACE THE BATTERY INDICATOR



Remove 2 screws on the cap



Dismantle 4 plugs, then you can dismantle the battery indicator and replace it.

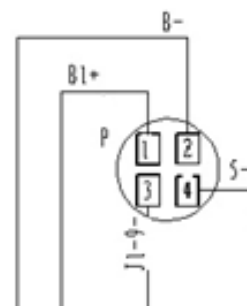

Circuit Diagram of Battery Indicator

REPLACE THE EMERGENCY BUTTON

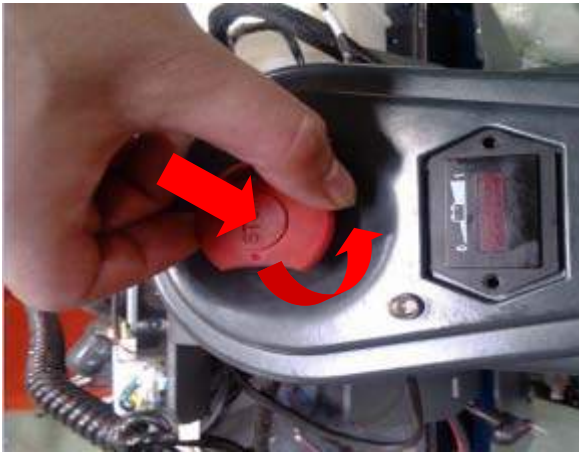

Press the button with anticlockwise rotation, then you can remove the emergency button lid.



Dismantle the cap, remove 2 screws



Dismantle the plug.



Lift the board ,and pull down the emergency button.

REPLACE THE FUSE



Remove 2 nuts, then you can change the fuse.

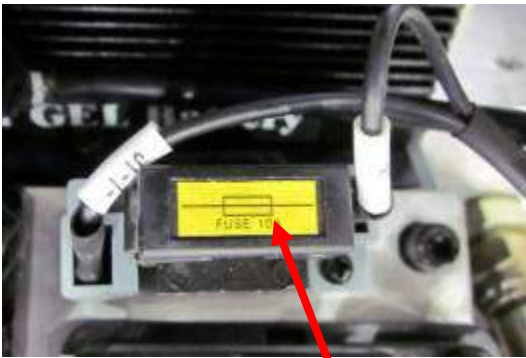

Open the cover of the fuse seat, then you can dismantle the fuse and replace it.

REPLACE THE RELAY

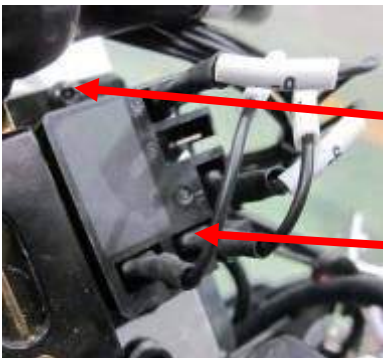

Dismantle two screws.

Dismantle the cables.
Then you can dismantle the relay and replace it

OPERATION OF THE CONTROLLER



When replacing the controller, be carefully to check the plugs, specially note the cathode pillar

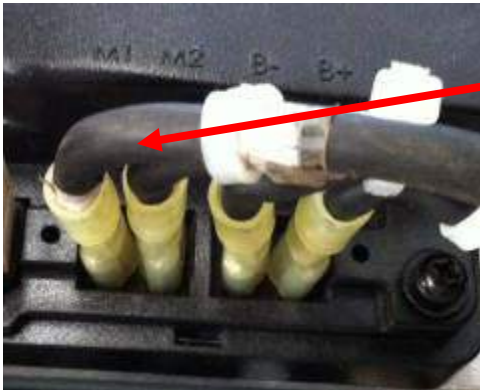

Two plug terminals (M1 and M2) are provided for the connections to the motor field winding. Do not allowed to access anti-Line, otherwise the motor will be reversed.

REPLACE THE PROTECT MODULE





When the temperature of the motor is more than 115°C, the protect module will give a signal to the controller, then driving speed will automatically change to low-speed mode. After the temperature reduces to 115°C, the speed mode will change to normal mode.

If one line of the cable open circuit, the driving speed will be slowly.

Dismantle the screw and the plug, then you can dismantle the protect module and replace it

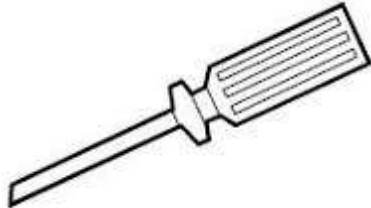
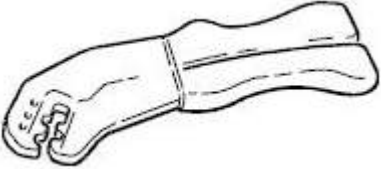
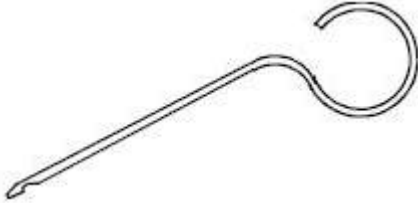
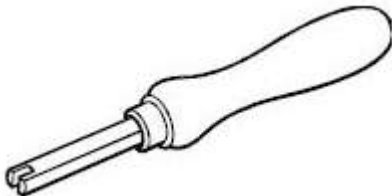
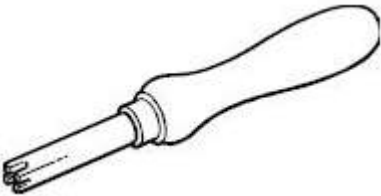
3.10 TOOL FOR REPAIRING THE PIN OF ELECTRIC PLUG

No.	Figure	Application
1		Tool for removal of pins / sleeves
2		Tool for application of pins / sleeves
3		Tool for release of lock
4		Tool for application of secondary locking 2 – pole
5		Tool for application of secondary locking 4 – pole
6		Tool for removal of pins / sleeves

4. HYDRAULIC SYSTEM

HYDRAULIC FLOW DIAGRAM

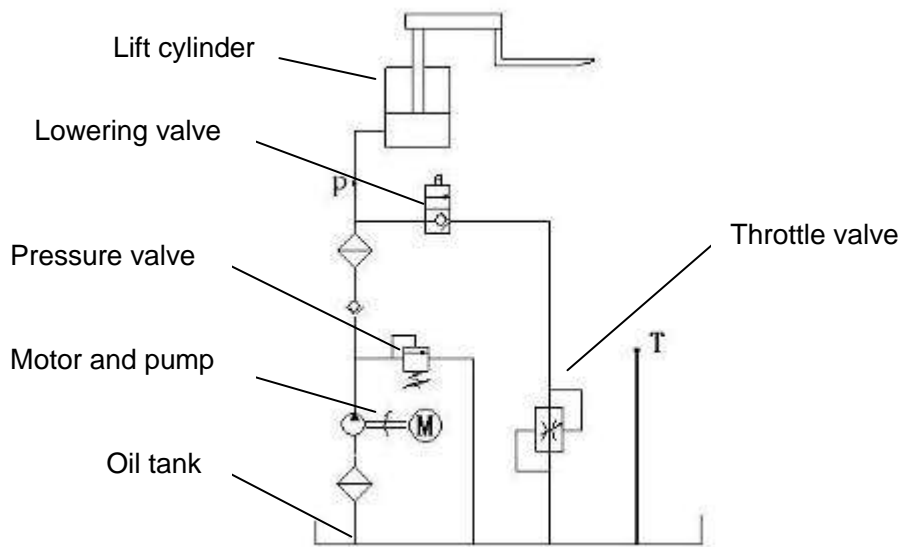

INSPECTION OF HYDRAULIC OIL

External appearance	Smell	Condition	Measurement
Clear and no discoloration	Fine	Fine	Possible to use
Clear but the color becomes brighte	Fine	Mixed with other oil	Inspect the viscosity and if fine it can be continuously used
Color changed like milk.	Fine	Mixed with air and water	Separate water or replace oil.
Color changed into dark brown	Bad	Oxidized	Replace oil.
Clear but there are small black spots	Fine	Mixed with other particles	Use after filtering.

4.1 PUMP STATION OPERATION

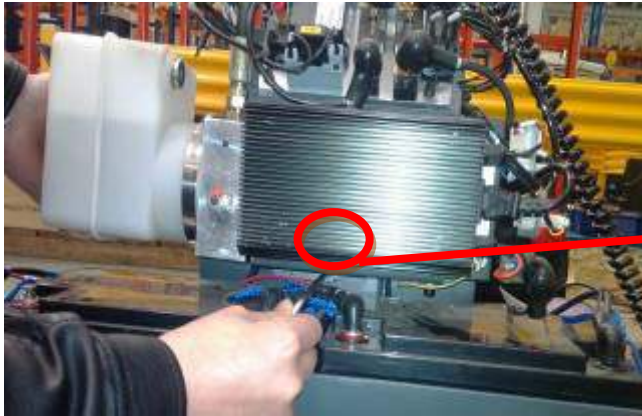

Remove M6 internal-hexagonal screws



Remove 2 screws on two sides, so that we can raise up the pump station.



Dismantle the power cable screw under the pump station with wrench





Dismantle 2 screws at the bottom of the pump station with internal-hexagonal wrench, so that we can replace the oil tank.

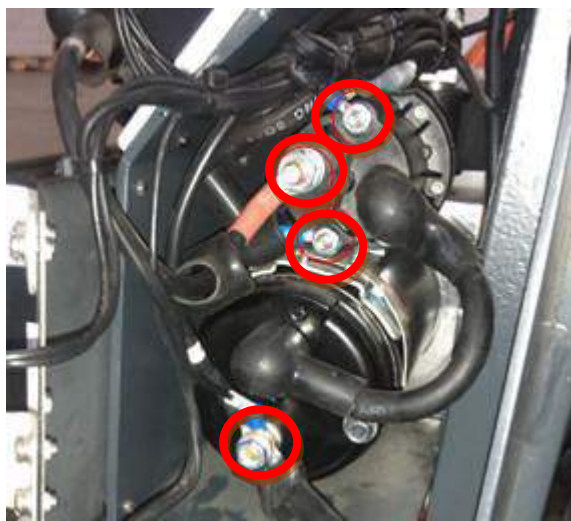
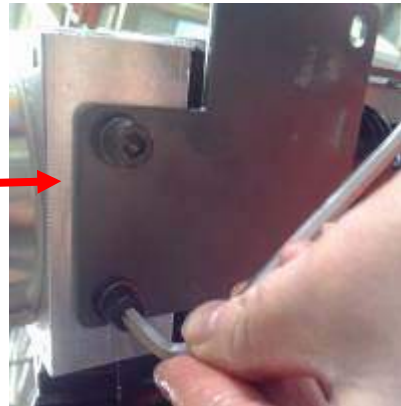

Remove 4 screws co pump station cable (following 2 pictures show the replacement of one screw)





Dismantle the magnet valve.

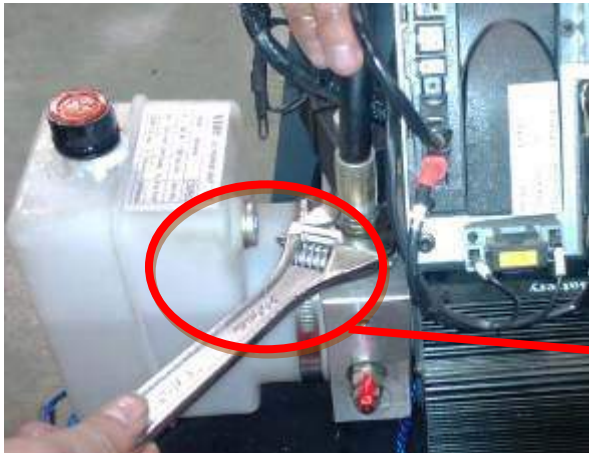

Dismantle the plug with wrench



Remove the pump station so that we can add oil and replace motor

CLEAN OIL TANK AND FILTER

⚠ WARNING Put the fork of the ground and drain out the hydraulic oil.



Dismantle the lid on the top of the tank , pour out the hydraulic oil

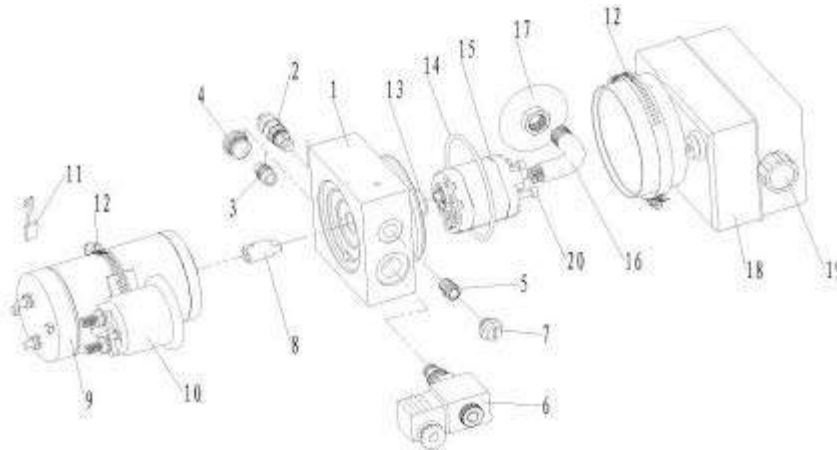

- Remove out the pump station.
- Loosen the hoop (No.12).
- Remove the oil tank (No.18)
- Remove the suction filter (No. 16 & 17).
- Cleaning of oil tank and filter.
- Clean the Fix plate for valve (No.7), etc.
- Clean up with compressed air and inspect if the filter is stopped or damaged. If the filter is stopped or damaged, replace it.
- Remove dust or foreign material from the tank.
- Then assemble them.

TROUBLE DIAGNOSTICS

Symptom	Abnormality and cause	Measurement
Bubble in hydraulic oil	Mixed with air	Check if there is any place where air can be entered. Tighten the loosened part again.
Discoloration	Mixed with air and water	Replace the oil.
	Became inferior in quality by oxidizing or mixed with other particles.	Replace the oil.

CAUTION

The **Plug Screw of port** for adding oil is ventilating. When lower, the air will come out from the tank, it might take out little oil vapor. So, it might appear little oil stains on the plug. Wait a little and ensure, that there is no oil leakage



CAUTION

For the electric current of the **Relay** for the lifting motor is very big, and work continually hourly, the contact terminal of the relay is easy damaged. Please check it continually.

CAUTION

The **Magnet valve** is a wearing part. If the forks automatically lower after lifting, the magnet valve may be blocked or damaged, remove it to clear or replace.



HYDRAULIC PIPE



CAUTION

For shocking, the **joint** of the **hydraulic pipe** and hydraulic pipe might be loosed and leak oil, so usually check and tighten it.

4.2 OPERATION OF CYLINDER

REPLACE THE CYLINDER

Firstly dismantle the connector of the cylinder.



Remove these 2 screws.
Using a crane to lift the truck, then the cylinder came out.

Dismantle the cylinder at the bottom of the chassis.



After dismantle the cylinder.

STRUCTURE

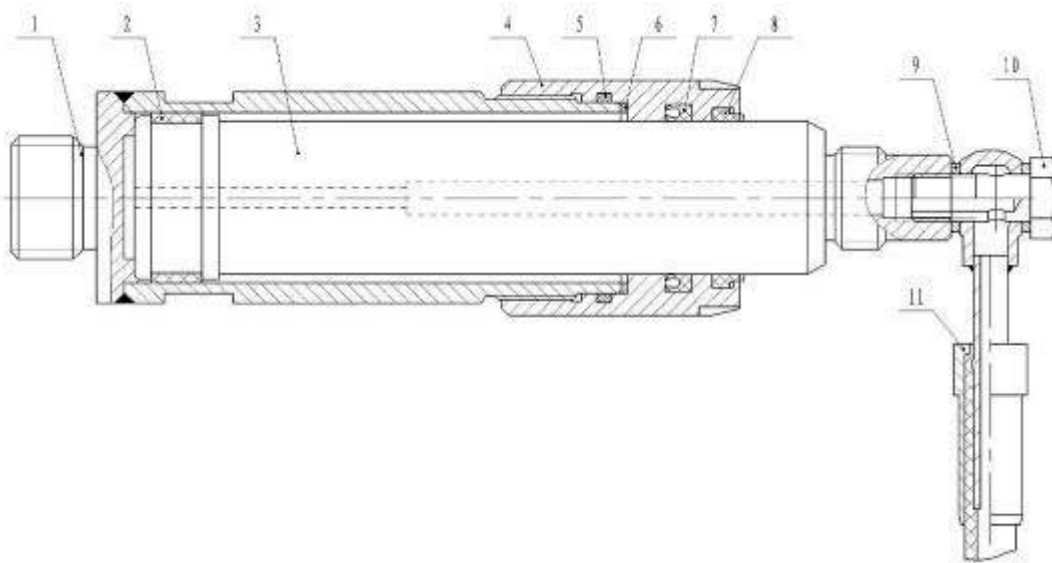

No.	Part name	No.	Part name
1	Cylinder body	7	Y-ring, $\phi 45 \times \phi 55 \times 8$
2	Guide ring	8	Dust ring, $\phi 45 \times \phi 53 \times 6.5$
3	Piston rod, $\phi 45$	9	Seal washer, $\phi 14$
4	Cover	10	Joint, M14x1.5
5	O-ring, 56x3.55	11	Hydraulic pipe
6	Seal ring		

4.3 HYDRAULIC OIL FILLING



Dismantle the lid on the top of the tank, and fill the oil.

5. DRIVE WHEEL

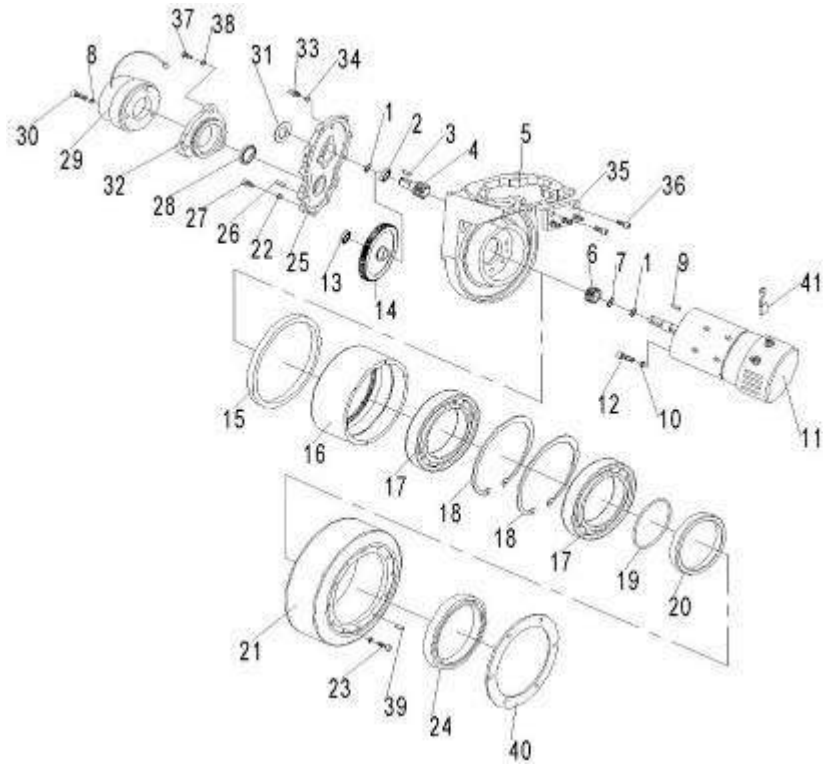

No.	Part name	No.	Part name
1	Retaining ring	22	Elastic washer
2	Bearing	23	Screw
3	Flat key	24	Sealing ring
4	Gear shaft	25	Gear box cover
5	Gear box	26	Roll pin
6	Small gear	27	Screw
7	Retaining ring	28	Skeleton oil seal
8	Elastic washer	29	Electromagnetic brakes
9	Flat key	30	Screw
10	Washer	31	Cover
11	Magnet motor	32	Protection cover
12	Screw	33	Vent-plug
13	Bearing	34	Combination washer
14	Big gear	35	Cable fixing plate
15	Skeleton oil seal	36	Screw
16	Internal gear ring	37	Screw
17	Bearing	38	Elastic washer
18	Retaining ring	39	Roll pin
19	O-ring	40	O-ring
20	Block filter seal	41	Carbon brush
21	Wheel		

5.1 REPLACE THE WHEEL

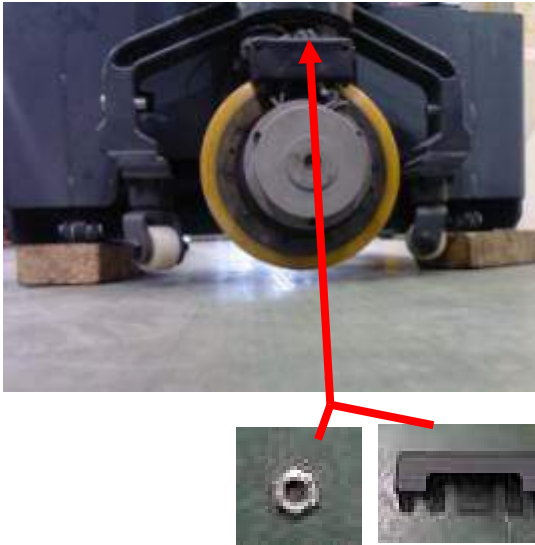

Lift the truck with wooden block, dismantle the cover.



Dismantle the power cable of the motor and the brake and the temperature sensor



Dismantle the screws of the cable plate



Remove the cable plate, the wheel appears.



Use four screws (8.8T or more better) to Screw in four "technologic screw holes", so that ejection the wheel.



Remove 10 pcs screws, then you can replace the wheel.

2 pc guide pin holes

10 pc screw holes

4 pc technologic screw holes

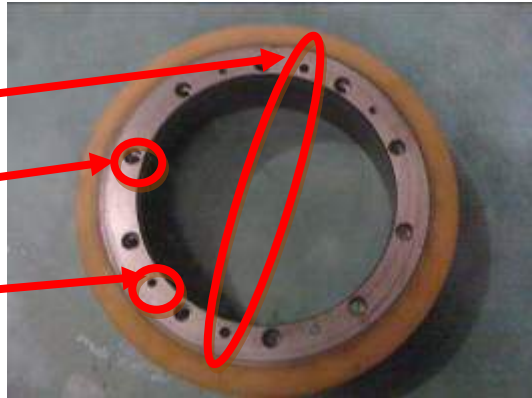

5.2 REPLACE THE ELECTRIC BRUSH

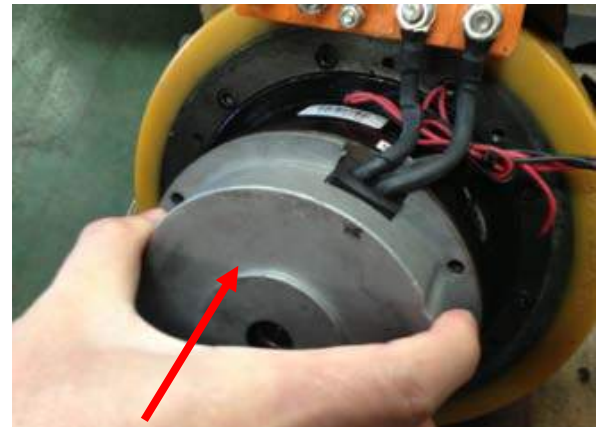
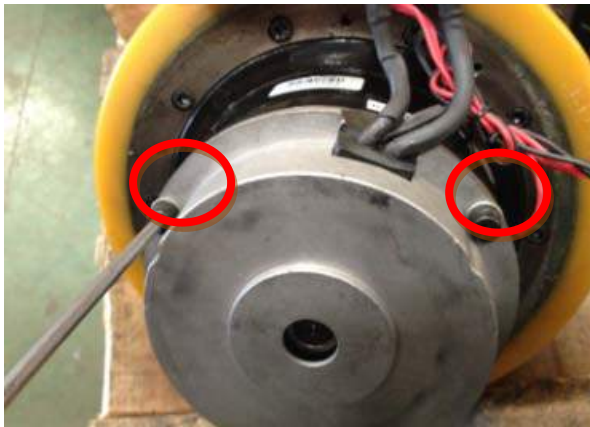

Remove 3 screws, and dismantle the fixed cover of electric brush



You can see the electric brush at the back of the cover.

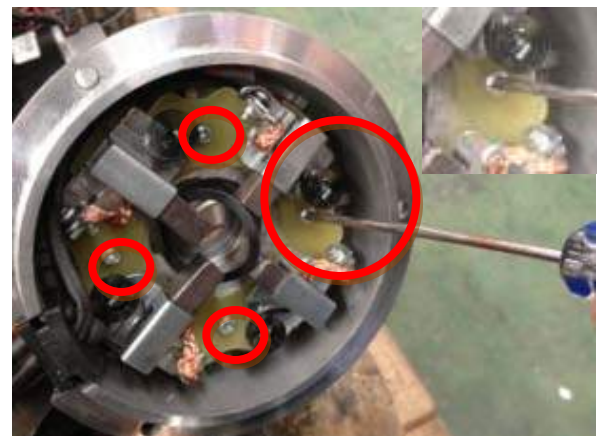

Remove 4 screws and dismantle fixed plate of electric brush



Remove the screw fixed the electric brush, dismantle the Electric brush spring, then you can remove and replace the electric brush.

5.3 REPLACE THE BRAKE

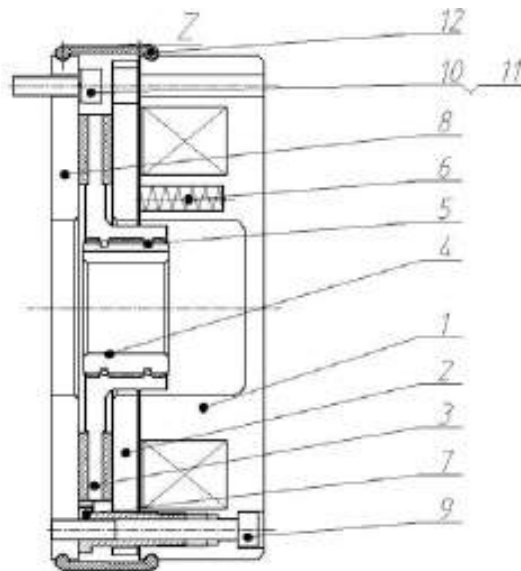

No.	Part name	No.	Part name
1	Fixed rotor	7	Hollow screw
2	Gag bit	8	Cover board
3	Friction disc components	9	Connect screw
4	Splined sleeve	10	Screw
5	O-ring	11	Elastic washer
6	Spring	12	Dust ring

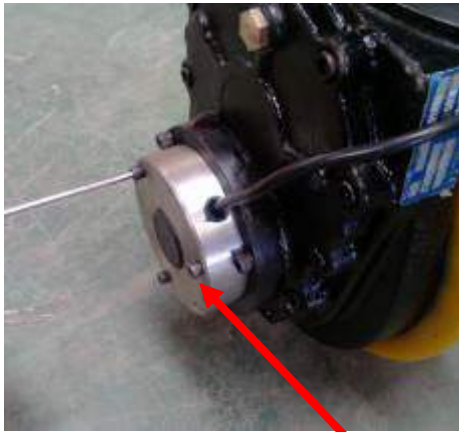

Remove 3 pc screws



Remove 3 screws and the circlip



Then you can replace the brake or repair it.

5.4 ADJUST THE AIR GAP OF THE BRAKE

Rated air gap z is large due to wear. To ensure that the brakes have enough brake torque, must adjust the air gap before it reach the maximum air gap. Air gap can be adjusted several times, when the thickness of the friction brake reach to the most small thickness, friction brake disc must be replaced. The brake torque noise is relative to the air gap.

When the air gap exceed the maximum value, it might cause the brakes not releasing, friction braking burn, braking or retention decrease, or even cause a major accident. Must be checked on a regular basis and adjust air gap, attention must disconnect the main power.

Step 1:
Adjust the three hollow screws

Step 1:
Loose the three screws that fix the brake



Step 3:
Use a feeler gauge to check the air gap z value is a rated air gap value or not

Keep the same clearance as showing

Standard torque (Nm)	Power (W)	Standard torque Air-gap (mm)	Install screw tightening torque (Nm)
5	20	0.3-0.35	2.8

Replace the brake or brake disc, if the air gap exceeds 0.35 mm.



CAUTION Brake slide should not contain grease, and nothing is blocked inside. Connected with plug connection, should connected firmly.

5.5 REPLACE THE DRIVE WHEEL



Push away the thrust pad.



Remove thrust screw with special tool



Remove the screws of both sides,
dismantle the cables on the drive wheel.
Pull out the handle-control cable and
remove the handle



Using a crane to lift the truck, remove the
drive wheel module



Remove the bearing, then you can replace it .



Remove 4 screws and remove the drive wheel seat, then you can replace the drive wheel.

6. CONTROL HANDLE

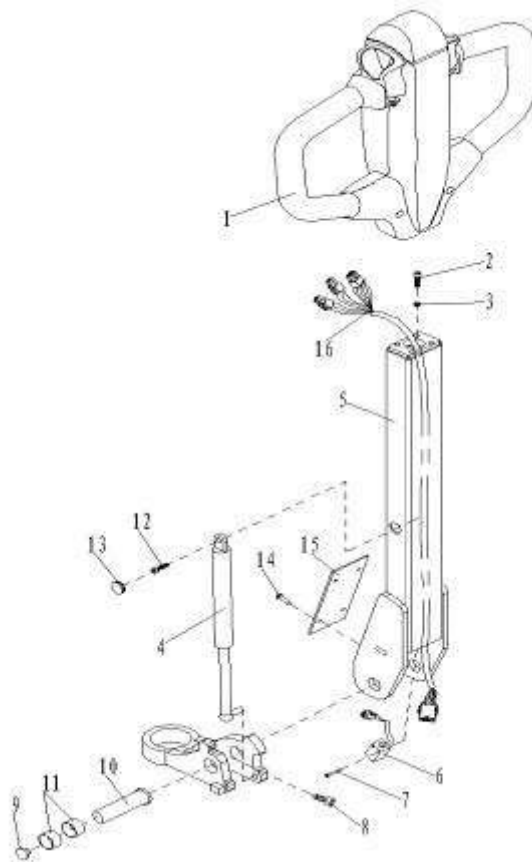

No.	Part name	No.	Part name
1	Tiller	9	Retaining ring
2	Screw	10	Shaft of tiller
3	Elastic washer	11	Washer
4	Air spring	12	Screw
5	Tiller arm	13	Cover
6	Proximity switch	14	Screw
7	Screw	15	Metal cover
8	Screw	16	Tiller cable

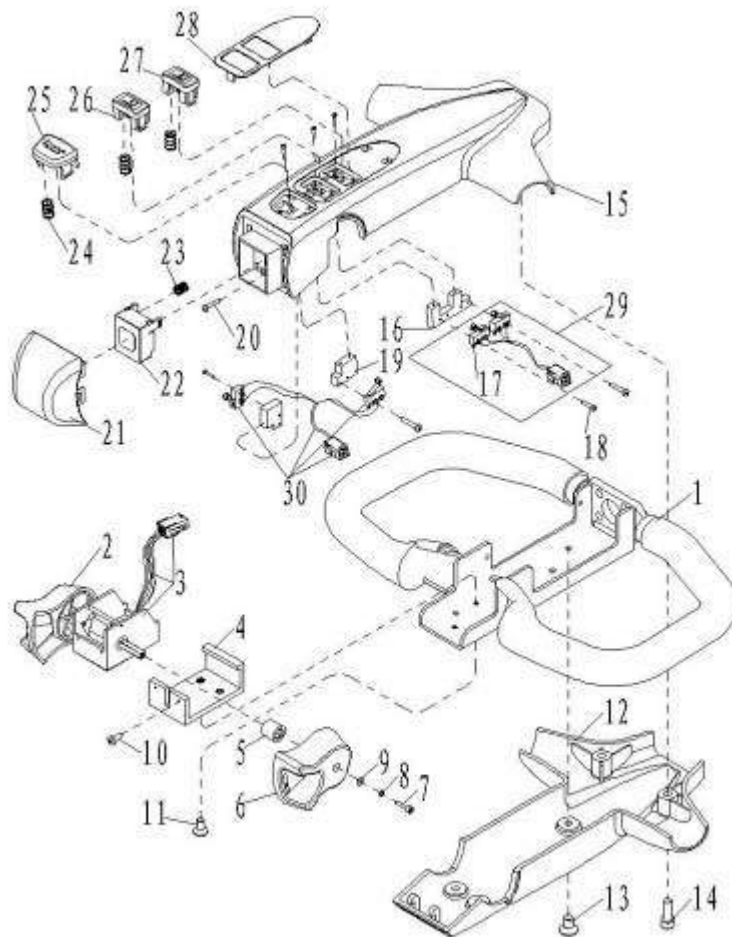

No.	Part name	No.	Part name
1	Tiller block	16	Micro switch plate
2	Left drive button	17	Micro switch
3	Accelerator	18	Screw
4	Accelerator connector	19	Micro switch plate
5	Plastic cover	20	Tapping screw
6	Right drive button	21	Belly button
7	Screw	22	Belly block
8	Elastic washer	23	Spring
9	Washer	24	Spring
10	Screw	25	Horn
11	Screw	26	Lifting button
12	Lower cover	27	Lowering button
13	Screw	28	Sticker
14	Screw	29	Micro switches 2
15	Upper cover	30	Micro switches 1

6.1 REMOVE THE AIR SPRING



Remove the rubber block.



Remove air spring screws with internal-hexagonal wrench.

Then you can check or replace the air spring.



6.2 REMOVE THE HANDLE

Remove the elastic collar with circlip pliers.



Strick out the shaft of the tiller bar.with a hammer, hold the other side so that keeping it from missing.



Dismantle 4 screws to remove the metal cover. The electric parts in the handle will appear. Check the cables if they're tight or not, you can snip the nylon belt with scissors to take out the plugs.

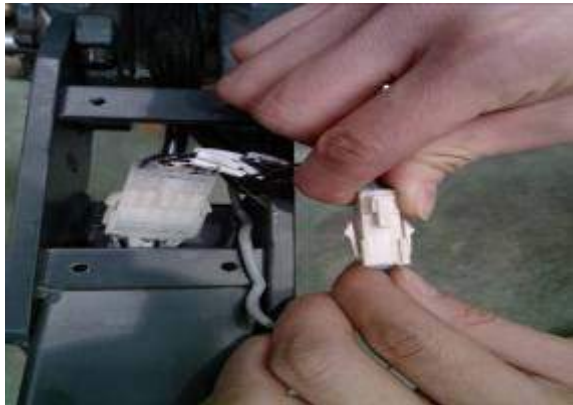

Dismantle the plugs with your hands, finally the handle can be removed from the truck.



The front and back of the handle

6.3 REPLACE THE SENSOR

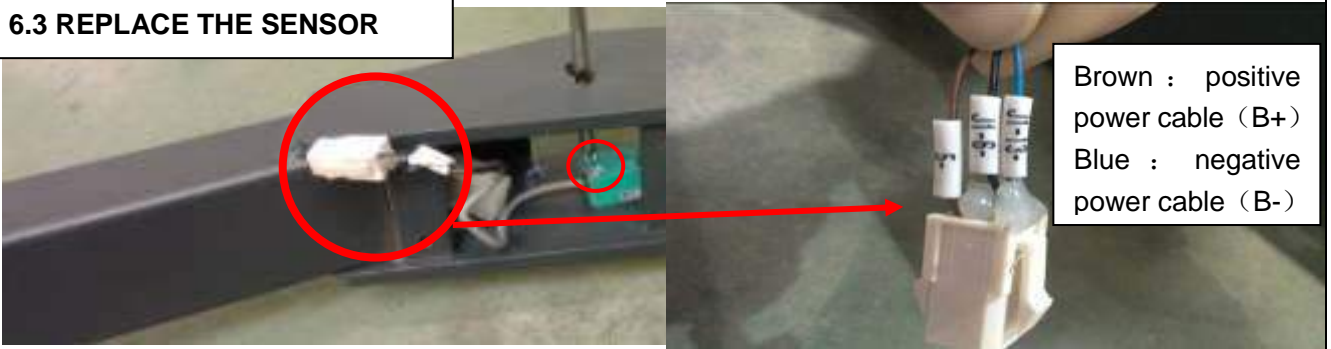

Dismantle 2 screws of the sensor, then you can check and replace it.

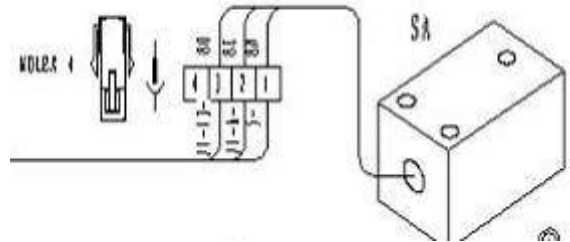

6.4 REPLACE THE TILLER



Remove 6 screws with internal-hexagonal wrench. Push slightly the upper cover about 10mm, then open it.



Remove 4 screws, then you can remove the tiller .

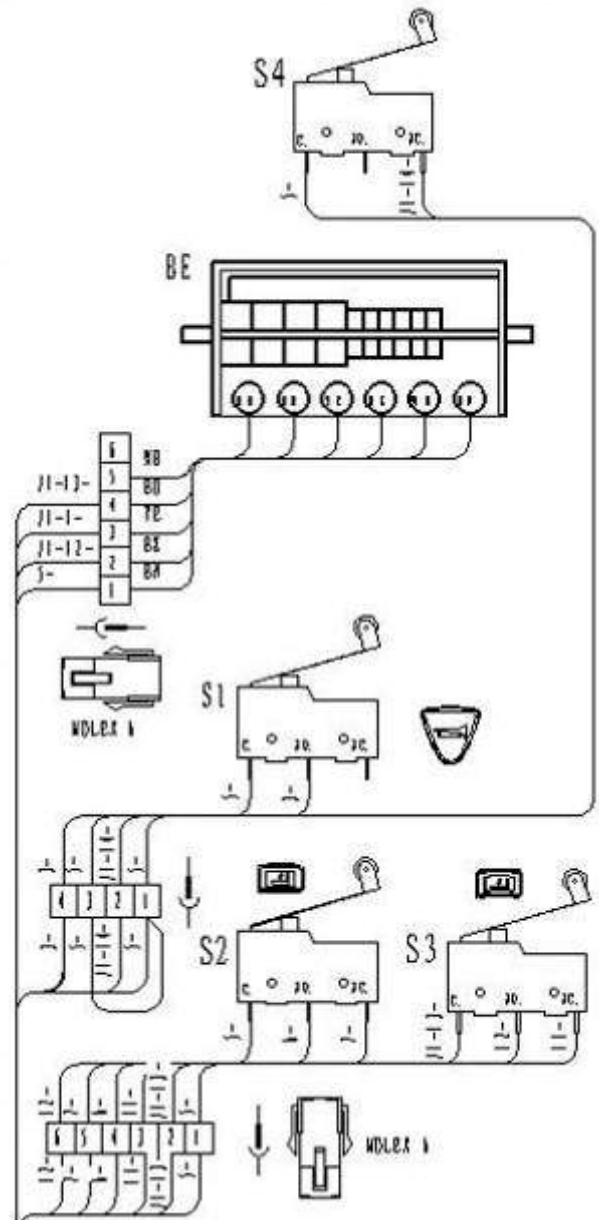

6.5 REPLACE THE ACCELERATOR



Remove 3 screws, then you can remove the module.

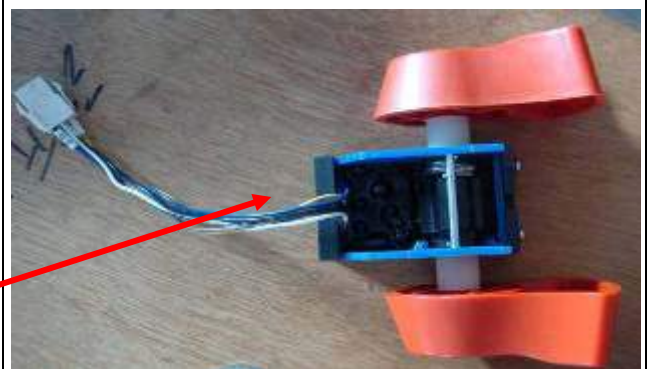

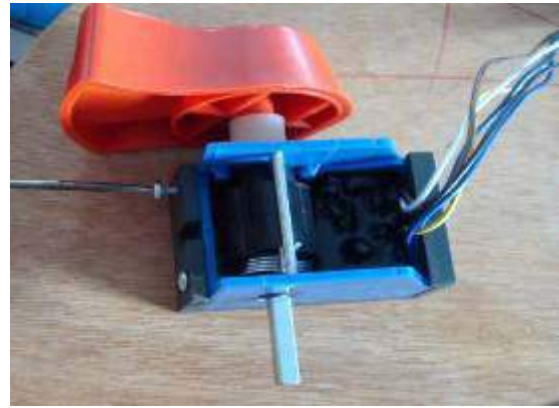
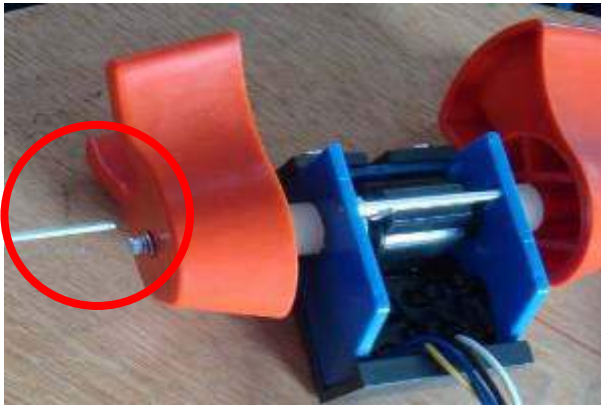

Dismantle the screw and remove the Butterfly. Take out the accelerator

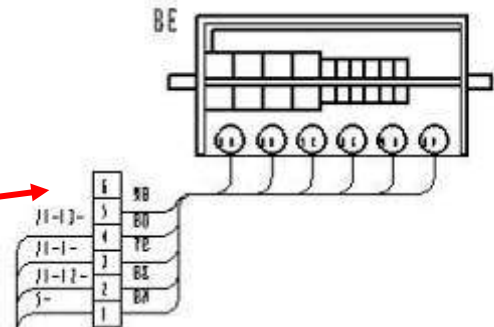
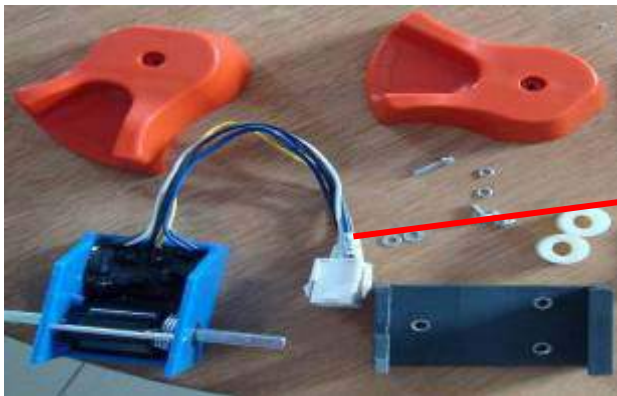

6.6 REPLACE THE MICRO SWITCHES



Dismantle the screws.



Dismantle the micro switches and replace them.
Ensure the micro switch is in the middle position.

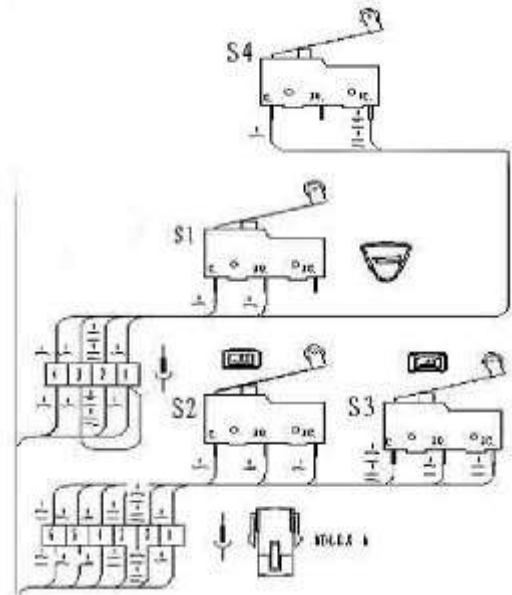

7. CASTER WHEEL

7.1 OPERATION OF THE CASTER WHEEL

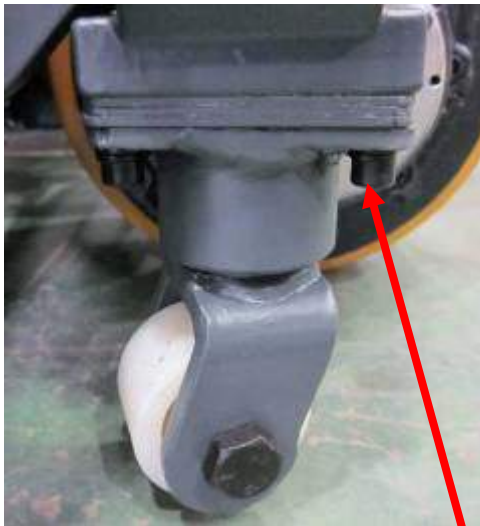

First, let the pallet truck to be slanting, second dismantle four screws. Then you can dismantle the caster and replace it.

7.2 ADJUSTING THE PRESSURE FOR THE DRIVE WHEEL

After using some time, the drive wheel might wear off, the pressure for the drive wheel will not be enough, and drive wheel can't bit into the ground and slip.

You can adjust it according to following steps:



Step 1: Remove the four screws

Step 2: Take away one or two piece washer.

Note: the normal gap of the wheel and ground is 3-4 mm.

8. MAINTENANCE CHECK LIST

			Maintenance Time Interval			
			Standard=●			
			W	M	M	M
			1	3	6	12
Chassis and truck frame	1.1	Inspection of any damage of bearing parts		●		
	1.2	Inspection of all joints of bolts		●		
Driving part	2.1	Inspection of noise and leakage of driving system		●		
	2.2	Replace lubrication				●
Wheel part	3.1	Inspection of wearing and damage state		●		
	3.2	Inspection of bearings inside wheels and ensure compact fit with wheels		●		
Steering system	4.1	Inspection of steering operation motion		●		
Braking system	5.1	Inspection of performance and adjust it		●		
	5.2	Inspection of reset function of filler gas spring and any leakage or damage		●		
	5.3	Inspection of wearing state of brake disc		●		
	5.4	Inspection of brake connectors and adjust if necessary		●		
Lifting equipment	6.1	Inspection of wear and adjust if necessary		●		
	6.2	Inspection by sight of any wear of loading wheel		●		
	6.3	Inspection of any wearing or damage of edge of forks and pallet		●		
Hydraulic system	7.1	Inspection of any leakage or damage of all joints		●		
	7.2	Inspection of any leakage or damage of hydraulic cylinder, safety and reliability of attachment		●		
	7.3	Inspection of hydraulic oil level		●		
	7.4	Replace hydraulic oil and filter				●
	7.5	Inspection of adjustment function of pressure valve				●
Electrical system	8.1	Check correct function of the accelerator of the tiller, replace it necessary		●		
	8.2	Inspection of safety and reliability of connection of all cables, and if any damage		●		
	8.3	Check the fuse size				
	8.4	Inspection of safety, reliability and function of switches and unlocking cam equipment		●		
	8.5	Inspection of connector, replace if damaged				
	8.6	Inspection of function of horn		●		
Motor	9.1	Check the air gap of the brake, adjust it if necessary			●	
	9.2	Test the emergency switch function		●		
	9.3	Clean motor frame with vacuum cleaner, inspection of wearing state of commutator			●	
Battery	10.1	Check battery housing, voltage of battery		●		
	10.2	Inspection of safety device , applicability of grease		●		
	10.3	Clean terminal of battery, inspection of compactness of fit		●		
	10.4	Inspection of damage of battery cable, replace it if necessary		●		
Lubrication	11.1	Grease the truck according to the time schedule of lubrication feeding		●		
Integrated measurement	12.1	Inspection of electrical leakage to the chassis				●
	12.2	Inspection of driving speed and braking distance				●
	12.3	Inspection of lifting and lowering speed				●
	12.4	Inspection of safety valve and closing valve		●		
Function	13.1	Check the indicator, replace it if necessary		●		
	13.2	Check the micro switches of the tiller, replace them if necessary		●		
	13.3	Check the horn function	●			
	13.4	Test the emergency braking	●			
	13.5	Test the reverse and regenerative braking	●			
	13.6	Test the safety (belly) button function	●			
Charger	14.1	Check the function of the charger, replace it if necessary			●	
Geneal	15.1	Check the clearance of the castors, adjust the distance if necessary		●		
Sticker	16.1	Check the sticker of the truck, add the new one if necessary	●			

9. TROUBLE SHOOTIN

