

Gillison's Variety Fabrication, Inc.



Tier III GVF Rough Terrain Forklift Owners Manual

Manual Part Number: GL 11497
Revised 11/13/2014

Model Numbers:

GVF 5000
GVF 6000
GVF 8000

3033 BENZIE HWY. BENZONIA, MI 49616 231-882-5921
FAX 231-882-5637 800-392-6059
email: info@gillisons.com
online: www.gillisons.com

Table of Contents

TABLE OF CONTENTS

INTRODUCTION 1

SAFETY 2

| | |
|------------------------------------|----|
| Forklift Mast Safety | 16 |
| Fork Safety | 11 |
| General Safety Rules | 3 |
| General Safety While Operating | 4 |
| Instruction Decals | 8 |
| Intro to safety | 2 |
| Load Handling Safety | 9 |
| Modifications | 10 |
| Ownership Records | 10 |
| Record Retention | 10 |
| Rules of the Road | 9 |
| Safety Alert Symbol | 2 |
| Safety While Operating | 9 |
| Safety While Servicing the Machine | 5 |
| Serial Number | 9 |
| Signal Words | 2 |

CONTROLS 17

| | |
|------------------------------|----|
| Instrument Panel Diagram | 17 |
| Instrument Panel Information | 17 |
| Various Controls | 19 |

OPERATION 21

| | |
|---------------------------|----|
| Cold Weather Starting Aid | 21 |
| Forklift Shutdown | 21 |
| Operating GVF Forklift | 21 |
| Pre Start Up | 21 |
| Starting The Engine | 21 |

LUBRICATION & MAINTENANCE 23

| | |
|-------------|----|
| Brake Fluid | 42 |
| Electrical | 44 |

| | |
|-----------------------------------|----|
| Filter Part Numbers | 50 |
| Hydraulic System | 42 |
| Instructions for Pressure Washing | 24 |
| Lubrication & Maintenance Chart | 23 |
| Mast Maintenance | 38 |
| PD70 Front Axle | 30 |
| Reference Documents: | 50 |
| SD55 Rear Axle | 32 |
| Tier III Air Cleaner | 25 |
| Transmission | 25 |
| <u>GVF WARRANTY 51</u> | |

INTRODUCTION

The information in this publication describes the safety requirements, operation, maintenance and servicing of the Gillison Forklift. Every effort has been made to provide correct and concise information to you, the operator, as available at the date of publication. Your Gillison dealer is available should items in this book or details of your machine not be understood.

This book is supplied with each machine to familiarize the operator with proper instructions needed for operation and maintenance. Studying and adhering to these instructions will insure optimum machine performance and longevity. A machine that is maintained properly and operated in the intended manner will provide greater dividends than one that is neglected and/or operated in a manner other than as intended. Design and servicing of this machine has been kept as simple as possible to permit maintenance operations to be carried out with tools normally available.

This book should be thoroughly read and understood prior to operation of this machine. Inexperienced operators should study contents of this publication and receive instruction from an experienced operator when possible. Your Gillison dealer can assist in areas concerning machine operation and provide details concerning safe operation. It is suggested that this booklet be kept readily accessible, preferably with the machine, for future reference if questions or concerns arise. If the original book should become lost or damaged, consult your Gillison dealer in regards to acquiring a replacement.

Customers are strongly advised to use an authorized Gillison dealer in connection with any service problems and adjustments that may occur.



CAUTION: READ THIS BOOK IN ITS ENTIRETY PRIOR TO OPERATING THE MACHINE. Use only parts from your Gillison dealer for repairs and/or replacement.



GVF Tier III Turbo Rough Terrain Forklift

SAFETY

INTRO TO SAFETY

The safety of the operator is one of the main concerns in designing a new piece of equipment. Designers build in as many safety features as possible. However, every year many accidents occur which could have been avoided by a few seconds of thought and a more careful approach to handling equipment. You, the operator, can avoid many accidents by observing the following precautions. To avoid personal injury, study the following precautions and insist those working with you or for you to follow them.

In order to provide a better view, certain photographs or illustrations in this manual may show an assembly with a safety shield removed. However, the equipment should never be operated in this condition. Keep all shields in place. If shield removal becomes necessary for repairs, replace shield prior to further operation.

SAFETY ALERT SYMBOL

FIG. 1: This is the safety alert symbol. It means **ATTENTION! BECOME ALERT! YOUR SAFETY IS INVOLVED!** Look for it, both in this manual and on safety decals on the equipment. It will direct your attention to information that involves your safety and the safety of others.



FIG. 1

SIGNAL WORDS

FIG. 2: The words **DANGER**, **WARNING**, or **CAUTION** are used with the safety alert symbol. Learn to recognize these safety alerts, and follow the recommended precautions and safe practices.



-  **DANGER** indicates an imminently hazardous situation that, if not avoided, will result in death or serious injury.
-  **WARNING** indicates an imminently hazardous situation that, if not avoided, could result in death or serious injury.
-  **CAUTION** indicates an imminently hazardous situation that, if not avoided, could result in minor or moderate injury.



FIG. 2

Replace any **DANGER**, **WARNING**, **CAUTION** or instructional decal that is not readable or is missing. The locations and part numbers of these decals are identified later in this section of the manual.

GENERAL SAFETY RULES

FIG. 3: Always keep this manual with the machine.

This manual must be made available to the operator of the machine at all times. Special care must be taken to keep this manual safe from the weather and in readable condition.

Read this manual carefully and learn how to use the machine correctly.

Do not let anyone operate this machine without thorough instruction.

Beware of bystanders, particularly children! Always look around to make sure that everyone is clear before starting the engine or moving the machine. This is particularly important with higher noise levels as you may not hear people shouting.

FIG. 4: No passengers allowed. Do not carry passengers anywhere on the machine.

Dismount and park machine in the correct manner. When dismounting and/or leaving the operator's platform FOR ANY REASON always:

1. Shift to Neutral.
2. Come to a complete stop.
3. Lower forks completely.
4. Park on level ground.
5. Activate parking brake.
6. Shut off engine and remove key.



WARNING: An operator should not use alcohol or drugs which can affect their alertness or coordination. An operator on prescription or 'over the counter' drugs needs medical advice on whether or not he/she can properly operate equipment.

FIG. 5: Wear protective clothing. Do not wear loose clothing, as this may catch on moving parts of the machine causing injury.

Always wear protective clothing and appropriate safety equipment.

It is recommended that suitable protective hearing and safety glasses be worn.

Do not attempt to service machine, clear obstructions or unplug blockages with the engine running. Always shut off the engine first.

Keep all shields and guards in place.



FIG. 3



FIG. 4



FIG. 5

FIG. 6: Additional equipment: A fire extinguisher and first aid kit should be carried with the machine or be kept readily available at all times.

Have emergency telephone numbers for immediate access.

GENERAL SAFETY WHILE OPERATING



CAUTION: READ THIS BOOK IN ITS ENTIRETY PRIOR TO OPERATING MACHINE.

Keep the machine properly maintained. Do not operate a machine when it is broken or has missing parts. Make sure that the maintenance procedures in this operator's book are completed before using the machine.

Check all controls regularly and adjust where necessary.

Periodically check all nuts and bolts for tightness, especially wheel nuts.

Clear the area. Ensure that all bystanders, particularly children, are at a safe distance before starting the engine.



FIG. 7: Be aware of electrocution hazards. To prevent injury or death from electrocution:

Stay away from overhead power lines when operating forklift in raised position. This machine is not grounded. Electrocution can occur without direct contact.

Be observant of the operating area and terrain. Watch for holes, rocks or other hidden hazards. ALWAYS inspect area prior to operation.



FIG. 8: Be aware of side hill hazard. To prevent serious injury or death:

DO NOT operate near edge of banks. Setback distance from bank should equal or exceed the overall height of the bank.

DO NOT operate on steep slopes as overturning may result.

If necessary to cross a steep slope, avoid turning uphill. Slow down and make a wide turn. Travel directly up or down the slope, never cross it. Keep the heavy end of the machine on the uphill side.

FIG. 9: Do not use starting fluid. Starting fluid must

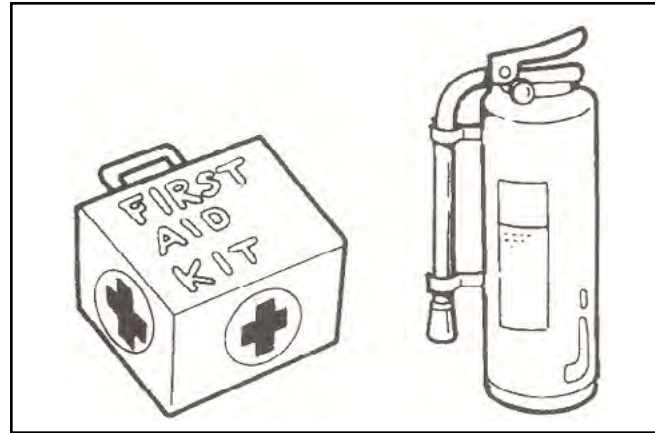

FIG. 6

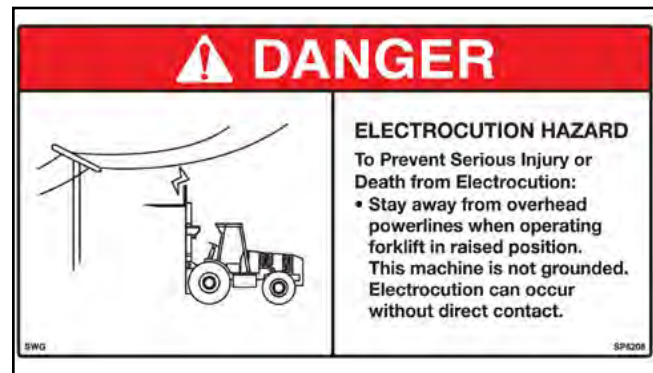

FIG. 7



FIG. 8

only be used when an ether-start aid is fitted as original equipment by the manufacturer or when installed by a dealer as an approved accessory.

The forklift is equipped with an intake heater. This must be removed prior to the use of starting fluid or ether aid.

Use of starting fluid on an engine equipped with an intake heater can result in severe engine damage.

Make sure there is plenty of ventilation. Never operate the engine in a closed building.

Always start and operate engine in a well-ventilated area.

If in an enclosed area, vent the exhaust to the outside.

Do not tamper with or modify the exhaust system with unapproved extensions.

SAFETY WHILE SERVICING THE MACHINE

Stop the machine. DO NOT service the machine while the engine is running or hot, or if the machine is in motion.

NOTE: When making major repairs or complicated adjustments, it is recommended that you consult your Gillison Dealer and have the work carried out by trained personnel.

The following precautions should be observed. These have been arranged by machine area or component.

Cooling System

FIG. 10: DO NOT remove the radiator cap (see 1) when the engine is running or hot.

DO NOT add coolant to the radiator while the engine is running.

Before removing the radiator cap, turn the cap slowly to relieve the pressure.

When adding coolant, make sure coolant being added is compatible and will mix with existing coolant.



FIG. 9

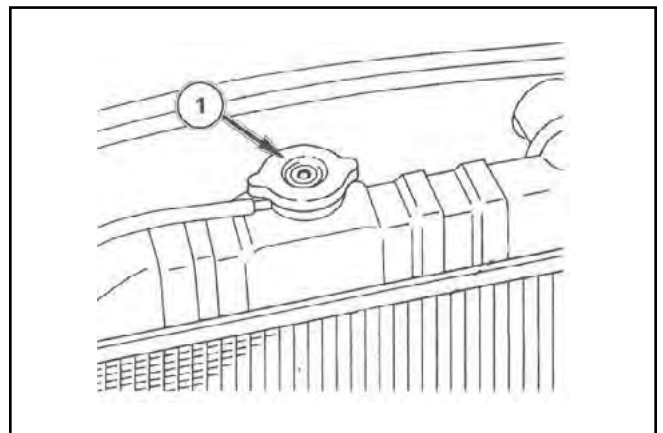
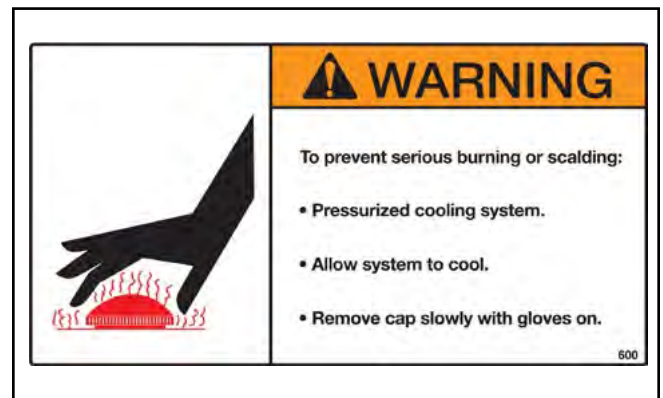

FIG. 10

Electrical System

FIG. 11: To prevent serious injury or death from exploding gases:



Do not work on batteries without proper instruction and training.

FIG. 12: Before making adjustments or servicing the electrical system, disconnect the battery negative (-) cable (see 1) first to prevent short circuits.

Keep sparks, flames and cigarettes away. Use a flashlight to check the battery electrolyte level if necessary.

Do not produce sparks with cable clamps when charging the battery or starting the machine engine with a slave (jumper) battery.

Batteries contain sulfuric acid electrolyte. Always wear protective clothing and eye protection when servicing.

In case of electrolyte contact, rinse area with plenty of water and seek medical attention.

Batteries produce explosive hydrogen gas when charged. Charge in area with adequate ventilation. Halt charging if battery temperature exceeds 52°.

Wash hands after handling battery.

Hydraulic System

FIG. 13: High pressure fluid hazard. To prevent serious injury or death:



Relieve pressure on system before repairing, adjusting or disconnecting.

Wear proper hand and eye protection when searching for leaks. Use wood or cardboard instead of hands.

Keep all components in good repair.

Ensure that all hydraulic connections are tight.

Relieve all pressures before disconnecting hoses or lines. Escaping oil under pressure can cause serious injury.

All fluids should be handled with care. If you are injured by or swallow any fluid, seek medical attention immediately and show the label on the product.

Fluid escaping from a very small hole can be almost invisible and can penetrate the skin causing serious injury. Keep hands and body away from pin holes and nozzles which eject fluids under high pressure. When



FIG. 11

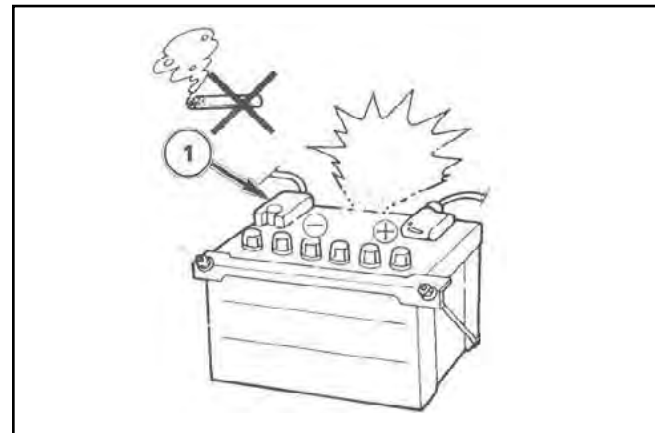

FIG. 12



FIG. 13

checking for leaks always use a piece of cardboard or wood. Never use your hands to find a pressure leak.

If ANY fluid is injected into the skin, it must be attended to by a doctor immediately.

Fuel System

FIG. 14: Diesel fuel is flammable and must be handled with care.

Never refuel or service the fuel system on the machine while smoking or when near open flames or sparks.

Never refuel the machine while the engine is running.

DO NOT use a fuel can unless necessary.

Always clean up any spilled fuel.

Fuel system components rely upon clean fuel for lubrication and optimum performance. Extreme care must be taken to prevent contamination from dirt and moisture so as to prevent damage to system.

Fuel injection system servicing must be referred to your Gillison Dealer. Unauthorized servicing may void all warranties.

Wheels and Tires

Do not attempt to service a tire unless you have the proper equipment and experience to perform the job. Have the work carried out by your Gillison Dealer or a qualified repair service.

The machine must be supported on suitable blocks or stands, NOT a hydraulic jack.

When seating tire beads onto rims, never exceed 2.4 bar (35 psi) or the maximum inflation pressure specified on the tire. Inflation beyond this maximum pressure may break the bead, or even the rim, with dangerous, explosive force.

When preparing a calcium chloride solution for fluid blasting the tires, NEVER pour water onto the calcium chloride. A chlorine gas can be generated which is poisonous and explosive. This can be avoided by slowly adding calcium chloride flakes to water and stirring until they are dissolved.

Wear suitable protective clothing, gloves and eye/face protection.

Replacement Parts

FIG. 15: Where replacement parts are necessary for periodic maintenance and servicing, replacement parts from Gillison's must be used to restore your equipment to original specifications.



FIG. 14

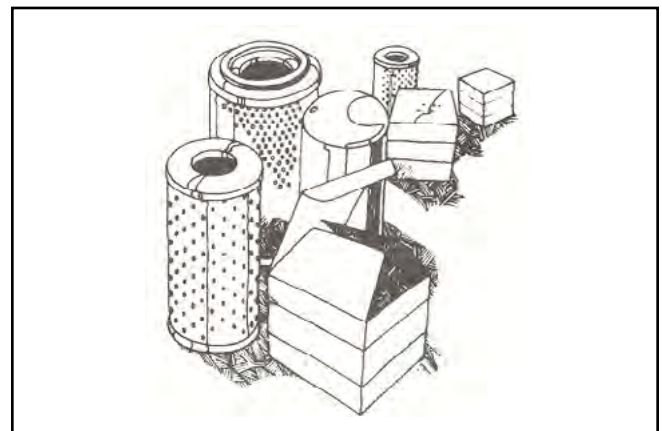

FIG. 15

Gillison's will not claim responsibility for installation of unapproved parts and/or accessories and damages as a result of their usage.

INSTRUCTION DECALS

FIG. 16: Location of all instruction decals are provided as a reference. Corresponding numbers show where decals belong on the machine. Replace any decals that are damaged, missing or are not readable. Consult your dealer.

Each decal below has its part number labeled below the decal.



1. SP 6255



2. SP 6260



3. SP 6210



4. SP 6207



5. SP 6285

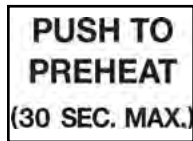

6. SP 6315

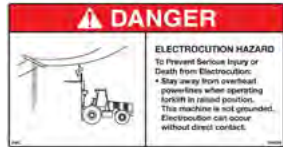

7. SP 6208

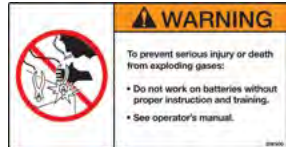

8. SP 6211



9. SP 6265



10. SP 6290



11. SP 6250



12. SP 6270



13. SP 6221



14. SP 6275

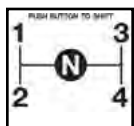

15. SP 6320

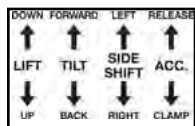

16. SP 6325

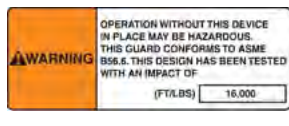

17. FOPS decal SP 6300

Decal Locations

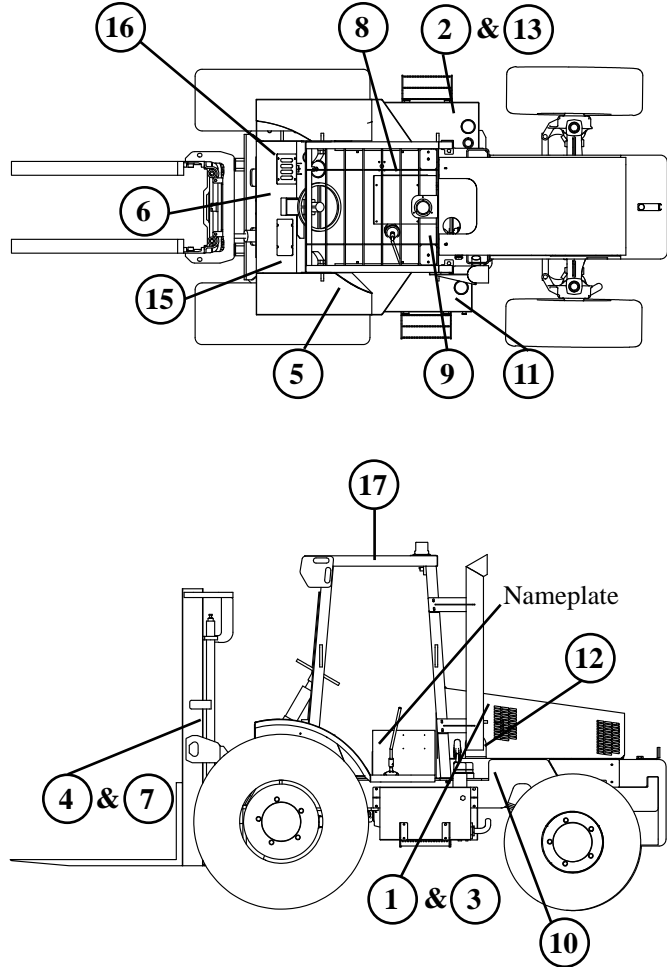

FIG. 16

| | | | |
|-----------------------------------------------------------------------------------------------------------------------------------------------|------------|--------------------------------------|-------------------|
| WARNING | | Gillison's Variety Fabrication, Inc. | |
| IMPROPER OPERATION OR MAINTENANCE COULD RESULT IN INJURY OR DEATH. READ AND UNDERSTAND THE OPERATION AND MAINTENANCE MANUAL BEFORE OPERATING. | | MODEL GVF 5000 | SERIAL NO. GL- |
| | | TYPE DIESEL | |
| CAPACITY WITH MAST VERTICAL AND EQUIPPED AS SHOWN | | | |
| TIRE PRESS. | FRONT | 35 PSI | |
| TIRE SIZE | 16.9-24 | 10 PLY | |
| | 12.5-80-18 | 10 PLY | |
| 11 DEGREES MAX BACK TILT | | MAST TYPE 55D MS | |
| DATE OF MANUFACTURE: | | | |
| DRIVE TREAD | IN | A | B |
| | 80 | 24 | 144 |
| | | C | TRUCK WT. |
| | | 24 | 12,100 |
| | | | CAPACITY |
| | | | 5000 |

TRUCK CONFORMS TO ASME B56.6

Nameplate - SP 6305

Includes important information such as: Warning, Model, Serial Number, Type, Tire Pressure & Size, Mast Type, Degrees Max Back Tilt, Date of Manufacture, Drive Tread, Truck Wt., Capacity

SERIAL NUMBER

Location of serial number is on the nameplate and is provided as a reference.

See FIG. 16

SAFETY WHILE OPERATING



FIG.17 Review ENTIRE operator's manual before operating this machine.

Fasten seat belt securely before starting.

Keep both hands on controls at all times when operating this vehicle.

Carry load low.

Use low range for hillside or ramp operation.

Block elevated components before servicing equipment.

Do not leave machine with mast raised.

Do not allow riders.

Do not leave machine with engine running.



FIG. 17

Heed these safety rules:

Inspect the forklift each day.

Perform scheduled maintenance to ensure optimum performance.

Wear proper clothing.

a. No baggy clothing

b. Use eye protection

c. Use hard hat

Fasten seat belt securely before starting the forklift.

When mounting and dismounting the forklift, use the steps and hand holds provided. Do not use steering wheel or controls.

Keep body, feet and hands inside the operators' platform when the forklift is running.

Do not operate the forklift under the influence of any kind of drugs or alcohol that impair judgment or performance.

Do not operate the forklift without overhead guard in place.

Lower forks completely to the ground when adjusting and when work is completed.

Do not allow anyone to stand under or work under raised forks.

Never raise persons with the forks.

Never leave forklift running unattended. Always set the parking brake, shift to Neutral, shut off engine and remove the key.

LOAD HANDLING SAFETY

Heed these safety rules:

When lifting or loading, tilt the mast back.

Use caution when tilting mast forward to ensure load does not shift off forks.

Never carry maximum rated load with center of load 24 inches above forks.

Avoid sudden starts and stops to prevent load from shifting.

Lift loads on level ground to prevent rollover.

Always watch for overhead obstructions when operating and lifting loads.

Do not exceed the lifting capacity of the forklift.

Always ensure forks of the proper capacity are used. Never interchange forks with forks of a different rating.

Do not add or subtract weight from the counterweight box.

RULES OF THE ROAD

Before operating your forklift on a public road, a number of precautions must be taken.

Familiarize yourself with, and obey, all laws appropriate to your machine.

Disengage FWD.

Make sure any required clearance flags or hazard lights are in place and in working order.

Clean off all reflectors and road lights, front and rear, and be certain they are in working order.

Make sure machine is equipped with a slow moving vehicle sign (SMV) and other marking materials recommended for improved visibility unless prohibited by law. FIG. 18

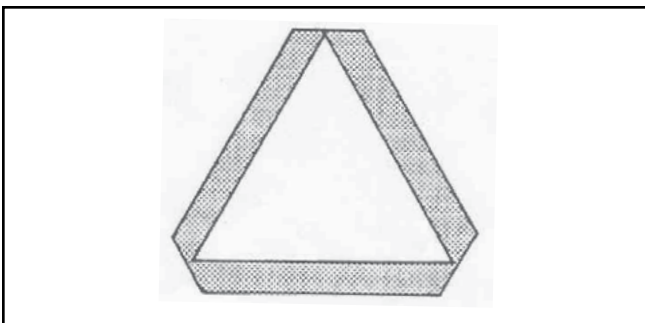

FIG.18

Know the route you will be traveling.

Use flashing lights when traveling on roads, day or night, unless prohibited by law.

Observe all local or national regulations regarding the road speed of your machine.

Use extreme caution when transporting on snow covered or slippery roads.

Wait for traffic to clear before entering a public road.

Beware of blind intersections. Slow down until you have a clear view.

DO NOT attempt to pass at any intersection.

Slow down for turns and curves.

Make wide, gentle turns.

Signal your intent to slow, stop or turn.

Shift to a lower gear before going up or down hills.

Keep machine in gear. **DO NOT** coast with the clutch disengaged or the transmission in neutral.

Stay out of the path of on coming traffic.

Drive defensively. Anticipate what other drivers might do.

Watch out for overhead obstructions.

MODIFICATIONS

Modification or alteration of the forklift shall be made only with prior written consent from Gillison's Variety Fabrication Inc.

Altering safety devices shall be prohibited.

RECORD RETENTION

The owner shall retain the following records for at least 3 years:

A. Purchase Information

B. Records of persons trained upon delivery of the GVF Forklift

C. Written records of frequent inspections, maintenance performed and parts replaced

OWNERSHIP RECORDS

When a change of ownership of a GVF Forklift occurs, it is the responsibility of the seller to notify Gillison's Variety Fabrication Inc. with the following information within 60 days of the sale:

A. Serial number of machine

B. Name & address of new owner

FORK SAFETY

Fork Inspection

Fork Inspection Log

Forks in use shall be inspected at intervals of not more than 12 months (for single shift operations) or whenever any defect or permanent deformation is detected. Certain applications will require more frequent inspections, and possibly non-destructive testing methods to check for cracks.



1. Inspect for surface cracks.

Pay special attention to the heel and welds attaching all mounting components to the fork blank. Forks with surface cracks shall not be returned to service.

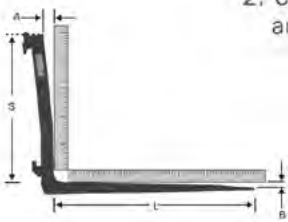

2. Check for straightness of blade and shank.

The fork should be withdrawn from service if the deviation from straightness exceeds allowable "A" and "B" values.

Allowable "A" = (.005) x (S)

Allowable "B" = (.005) x (L)

Example: 48" or 1,219 mm long blade

Allowable B = (.005) x (48") = .24"

or B = (.005) x (1,219) mm = 6.10 mm

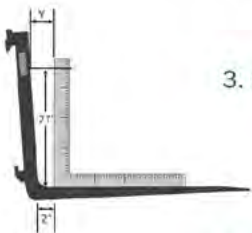

3. Check for excessive fork angle.

When Y value exceeds 2 3/8" (60 mm) or 2 3/4" (70 mm) on fully tapered, the fork is rejected.

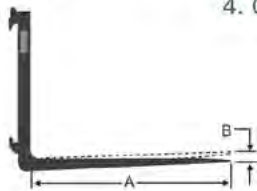

4. Check tip alignment.

When "A" is less than or equal to 42" (1,067 mm), then the maximum recommended difference in fork tip elevation is B = .25" (6.35 mm). If "A" is greater than 42" (1,067 mm), then the maximum recommended difference in fork tip elevation is B = .375" (9.53 mm).



5. Check for positioning lock damage.

Check the positioning lock and other fork retention devices to make sure they are in place and working.

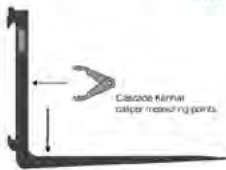

6. Check for wear.

Set the top jaws of caliper by measuring the thickness of the shank. Position the bottom jaws over the flanks of the fork arm blade. If inside jaws of caliper hit fork, it is OK. If inside jaws of caliper pass over the fork arm, it must be taken out of service. Refer to clipboard.



7. Check fork marking.

If the fork identification marking is not clearly legible, it shall be renewed.

| Lift Truck Serial # _____ | | |
|---------------------------|--------------|-----------------------|
| Inspection Date | Inspected By | Observations/Comments |
| 1. _____ | _____ | _____ |
| 2. _____ | _____ | _____ |
| 3. _____ | _____ | _____ |
| 4. _____ | _____ | _____ |
| 5. _____ | _____ | _____ |
| 6. _____ | _____ | _____ |
| 7. _____ | _____ | _____ |

Fork Inspection Cont.

USER FORK WEAR STANDARDS

Reprinted from ASME/ANSI B56. 1-2000

6.2.8 Inspection and Repair of Forks in Service on Fork Lift Trucks

(a) Forks in use shall be inspected at intervals of not more than 12 months (for single shift operations) or whenever any defect or permanent deformation is detected. Several applications will require more frequent inspection.

(b) Individual and Load Rating of Forks. When forks are used in pairs (the normal arrangement), the rated capacity of each fork shall be at least half of the manufacturer's rated capacity of the truck, and at the rated load center distance shown on the lift truck nameplate.

6.2.8.1 Inspection. Fork inspections shall be carried out carefully by trained personnel with the aim of detecting any damage, failure, deformation, etc., which might impair safe use. Any fork which shows such a defect shall be withdrawn from service, and shall not be returned to service unless it has been satisfactorily repaired in accordance with para 6.2.8.2.

(a) **Surface Cracks.** The fork shall be thoroughly examined visually for cracks and if considered necessary, subjected to a non-destructive crack detection process, special attention being paid to the heel and welds attaching all mounting components to the fork blank. This inspection for cracks must also include any special mounting mechanisms of the fork blank to the fork carrier including bolt type mountings and forged upper mounting arrangements for hook or shaft type carriages. The forks shall not be returned to service if surface cracks are detected.

(b) **Straightness of Blade and Shank.** The straightness of the upper face of the blade and the front face of the shank shall be checked. If the deviation from straightness exceeds 0.5% of the length of the blade and/or the height of the shank, respectively, the fork shall not be returned to service until it has been repaired in accordance with para 6.2.8.2.

(c) **Fork Angle (Upper Face of Blade to Load of the Shank).** Any fork that has a deviation of greater than 3 deg. from the original specification shall not be returned to service. The rejected fork shall be reset and tested in accordance with para 6.2.8.2.

(d) **Difference in Height of Fork Tips.** The difference in height of one set of forks when mounted on the fork

carrier shall be checked. If the difference in tip heights exceeds 3% of the length of the blade, the set of forks shall not be returned to service until repaired in accordance with para 6.2.8.2.

(e) **Positioning Lock (Where Originally Provided).** It shall be confirmed that the positioning lock is in good repair and correct working order. If any fault is found, the fork shall be withdrawn from service until satisfactory repair has been effected.

(f) Wear

(1) **Fork Blade and Shank.** The fork blade and shank shall be thoroughly checked for wear, special attention being paid to the vicinity of the heel. If the thickness is reduced to 90% of the original thickness, the fork shall not be returned to service.

(2) **Fork Hooks (Where Originally Provided).** The support face of the top hook and the retaining faces of both hooks shall be checked for wear, crushing, and other local deformations. If these are apparent to such an extent that the clearance between the fork and the fork carrier becomes excessive, the fork shall not be returned to service until repaired in accordance with para 6.2.8.2.

(g) **Legibility of Marking (When Originally Provided).** If the fork marking in accordance with para 7.25.2 is not clearly legible, it shall be renewed. Marking shall be renewed per instructions from original supplier.

6.2.8.2. Repair and Testing

(a) **Repair.** Only the manufacturer of the fork or an expert of equal competence shall decide if a fork may be repaired for continual use, and the repairs shall only be carried out by such parties. It is not recommended that surface cracks or wear be repaired by welding. When repairs necessitating resetting are required, the fork shall subsequently be subjected to an appropriate heat treatment, as necessary.

Fork Inspection Poster

Fork Inspection

and guidelines

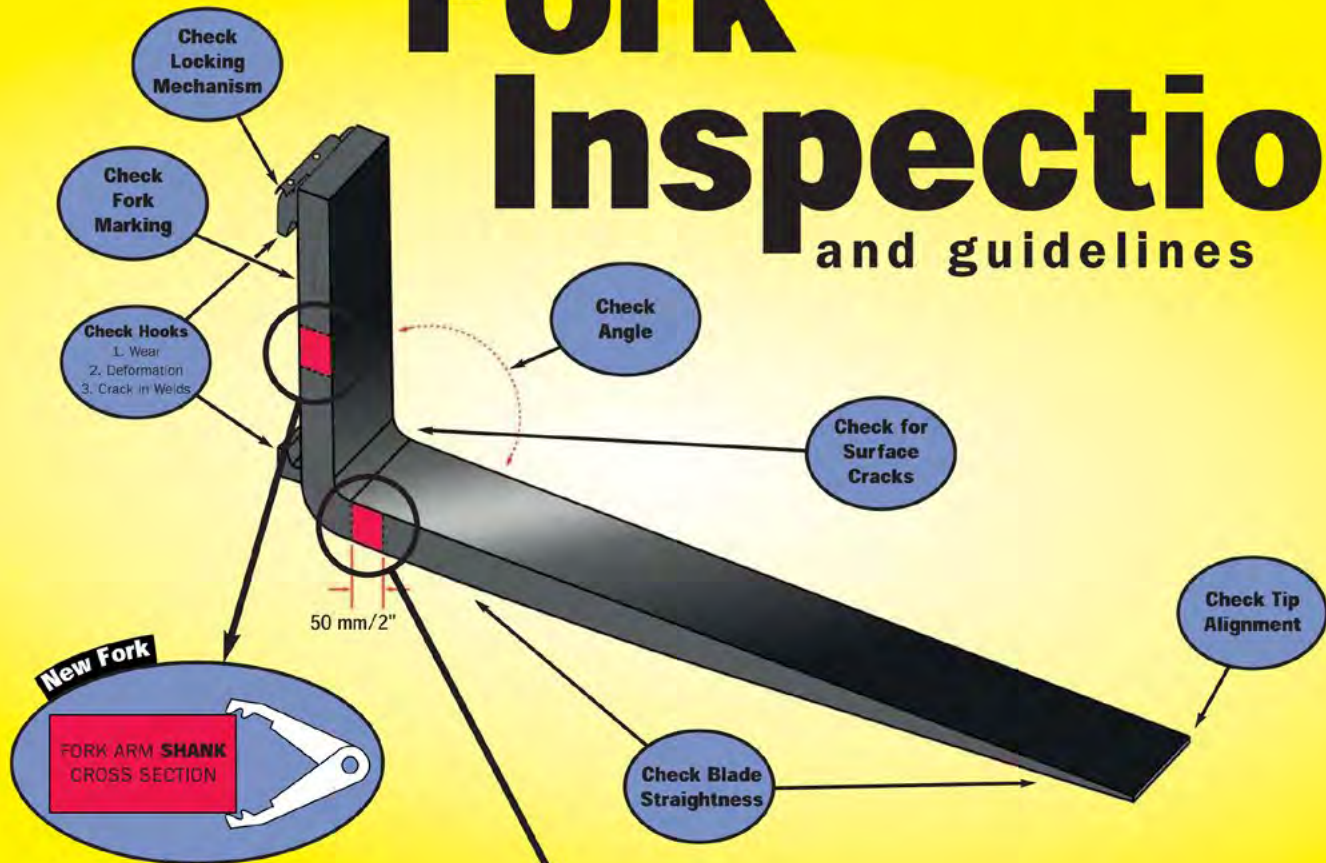

Step 1. Set Calipers

Checking shank thickness: Set the top jaws by measuring the thickness of the shank. Ensure that the caliper is held square across the shank for an accurate reading. The caliper is now set to measure the fork arm blade.



Step 2. Check Blade Thickness

Checking blade thickness: Position the bottom jaws of the caliper over the flanks of the fork arm blade. If inside jaws of caliper hit fork it has less than 10% wear and can remain in service.

Note: Standard Cascade Kenhar calipers can be used on forks up to and including 65 mm (2.56") thick. They are **NOT TO BE USED ON FULL OR LUMBER TAPERED FORKS** where the upright thickness is greater than that of the blade. In these cases 10% reduction must be obtained by measurement. You will need to know the original fork blade thickness.

Replace Fork

REPLACE

Step 3. Replace if Necessary

If inside jaws of caliper pass over the fork arm it must be taken out of service. This represents 10% wear and 20% reduction in capacity. ASME B56.1 recommended practices advise that forks be withdrawn from service when the thickness of the blade has worn by 10%.

Fork Use Guidelines:

Use your forks correctly:

1. Inspect forks regularly and use Cascade Kenhar inspection log.
2. Make sure capacity meets or exceeds truck rating and load weight.
3. Obtain written approval from fork manufacturer prior to making fork modifications.
4. Determine fork wear cycle and replacement schedule for your operation. Use of larger forks in demanding applications will extend fork life.
5. All locating pins must be in place at all times. Forks must be properly seated on the carriage and the pins fully located in the slot before use.

What not to do:

1. Do not overload beyond the rated capacity.
2. Do not change fork from one lift truck to another without knowing capacities of each.
3. Do not use a fork in an application for which it is not designed.
4. Do not add a fork extension longer than 150% of the supporting fork's length.
5. Do not try to repair or modify forks in the field, especially by welding. Improper welding destroys heat treat properties and makes the forks brittle.
6. Do not carry full or partial loads on one fork.
7. Do not apply sideways pressure to forks, commonly called "side loading", as they are designed for vertical loading only.

Fork Maintenance

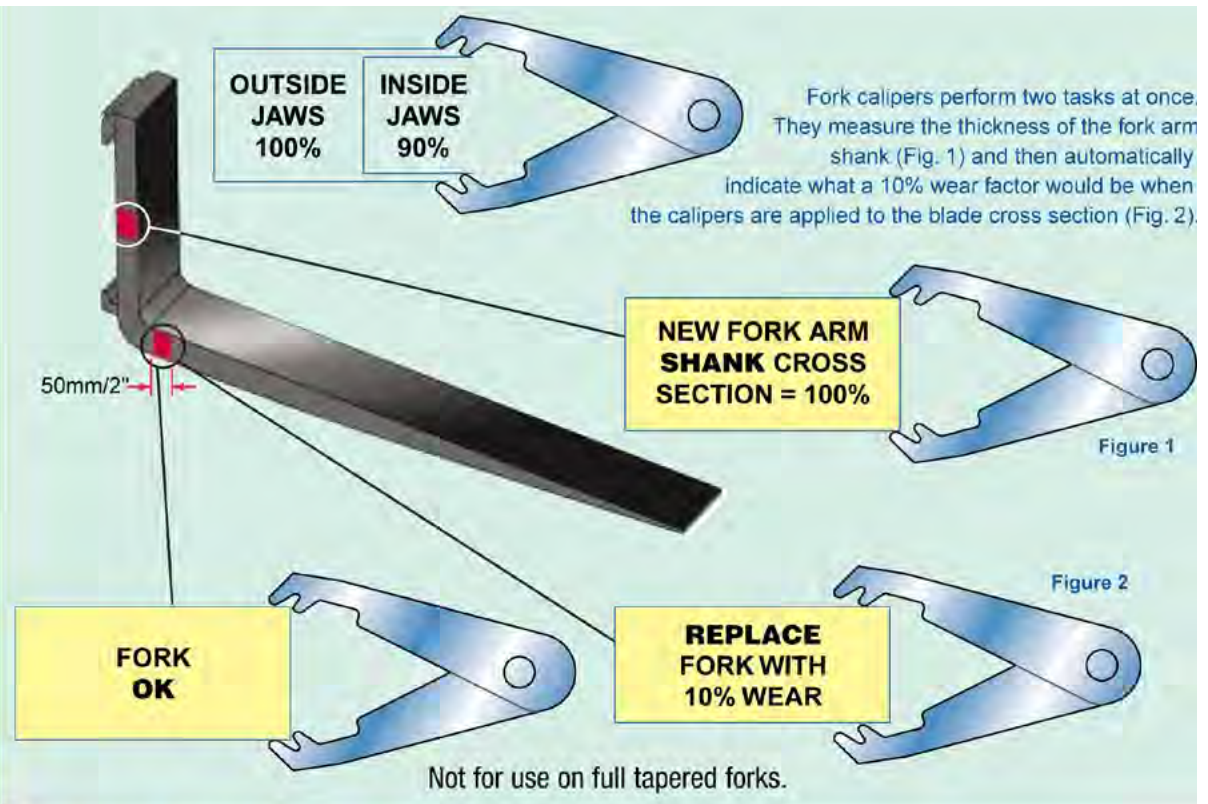

Lift truck forks: maintenance and inspection.

Lift truck forks are often mistreated and forgotten. As insubstantial as they seem, neglecting forks could make them dangerous. There is barely a word about forks mentioned in most operator training manuals or instructed courses. Lift truck technicians may ignore them completely. Yet, forks carry larger loads than almost any lifting device but there are no mandatory requirements for maintenance or inspection.

You can find thousands of extra parts for lift trucks in some fleet repair shops, but you'll seldom see spare forks. Even when all the trucks on the fleet are the same, fleet maintenance managers rarely order spare forks. Forks last a long time if treated properly, but they can deceive by looking as good from most viewing angles when they are worn as when they are new.

It's true that most forks are customized to the truck by model and capacity: they are big and heavy and thought of as indestructible. But forks can be abused or ruined in the course of daily work.

Here are some examples of ways that forks can be damaged:

- Forks can be overloaded either by picking up a load too far out on the forks, or simply by picking up loads heavier than the truck rating.
- Maintenance shops may bend forks back into shape, weld on them, or drill holes through them. Lift truck users can add attachments to the truck that stress the forks. Drum clamps and portable booms can be supported on the

forks—but what is contained in the drum or on the boom hook makes the safety difference.

- Forks are often used to open rail car doors and break loads out or away from other loads. They are also used to pick up capacity loads not seated against the fork shank and to pick up off-balanced loads far from the side of the truck. The fork tips are sometimes inserted under other fork trucks to lift them during maintenance operations.
- Lift trucks may collide with building columns and walls, and though the forks show no discernible bend, they may be damaged beyond safety.
- Any time excessive heat is applied to any part of a fork—during repair, for instance—hidden damage may occur.

The fork itself is a concern but so are the hooks that secure them to the lift carriage.

DESIGNED TO TAKE A BEATING

Forks for counterbalanced and straddle lift trucks are not just bent bars of steel. The manufacturing process is careful and precise with many checks and inspections critical to their safety. Some factors essential to fork manufacture include the steel, the bend and thickness of the heel, the welding of the hooks that hold them on the carriage, and the heat treatment of the finished product.

A 10% reduction in blade thickness results in a 20% reduction of capacity.

Fork Maintenance Cont.

FORKS ARE A WEARING PART

Finished forks are usually painted red, yellow or black when the truck is new. The paint is quickly scrapped off once the truck is put into service. The top paint is abraded by the pallet or load and the bottom is worn mostly by contact with the floor.

Lift truck operators are taught to keep their forks low and parallel with the travel surface when traveling empty and tilted back when carrying a load. But some operators go to extremes and travel with the heel of the fork riding on the floor. This practice wears the heel or the bottom surface of the fork and reduces the capacity of the fork.

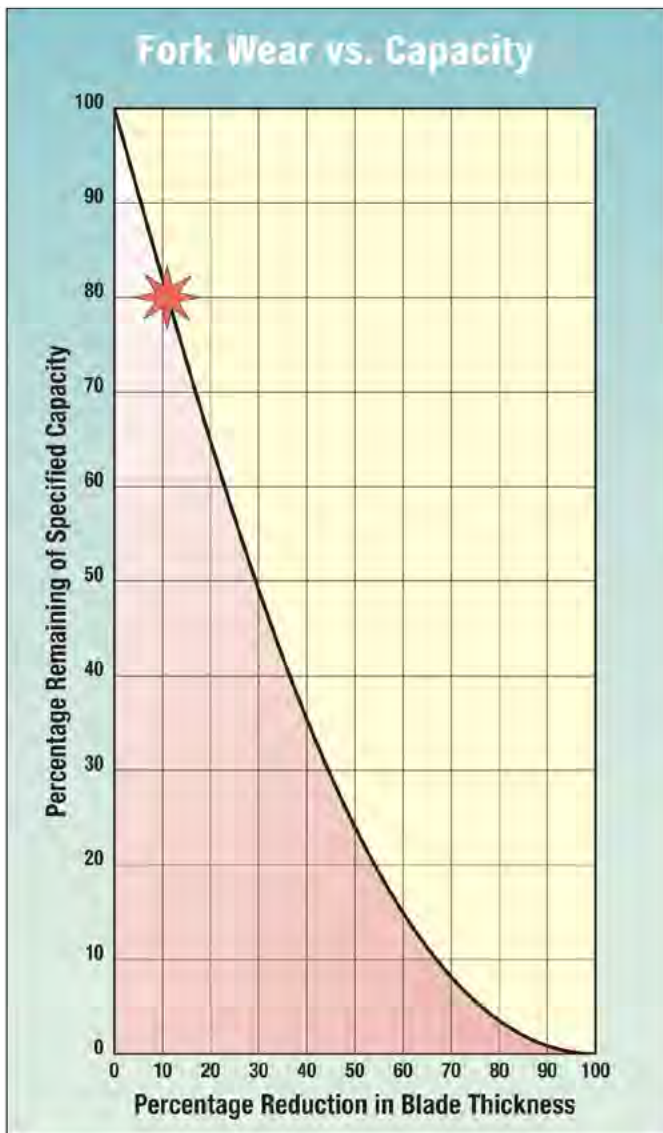

This chart shows how fork wear reduces truck capacity. ANSI standards require that each fork be rated at least half the capacity of the truck at the rated load center distance as shown on the truck nameplate.

Once in service, the bottom of forks may wear badly. This wear may not be noticed, but the consequences are. There are ASME/ANSI specifications for User Fork Wear Standards. They are part of the B56 standards by which lift trucks are manufactured and tested. Few operators or fleet managers know of the standards or understand that forks must be inspected.

While the Industrial Truck Association (ITA) recommends that forks be withdrawn from service when fork blade thickness has been reduced by 10%, few users understand that a 10% reduction in blade thickness results in a capacity reduction of 20%. This means that the safety factor for a pair of forks has also been reduced by 20%.

Measuring fork wear is not intuitive. You should make it a part of maintenance or inspection routines.

HERE'S HOW FORKS ARE INSPECTED

Forks should be inspected at least once a year (single-shift operation, and more frequently in severe applications) for wear and distortion. The best method is to use a fork caliper, which is a type of adjustable go/no-go gauge.

Each fork consists of two sections: the shank, which is the vertical part attached to the carriage, and the blade, which is the portion that picks up the load.

The caliper is first set using the shank of the fork on which there is little or no wear. (See the illustration.) Then that dimension is used to check the shank back near the heel of the blade. The four contact points of the special fork caliper automatically measure the wear on the blade.

Wear is checked by first measuring the thickness of the vertical shank portion of the fork because this part wears little. The interior part of the caliper has two additional points that automatically show a 10% reduction of the shank thickness. These points are slid over the fork blade. If the caliper slides down the blade to the heel, the fork is worn beyond safety and usefulness. It should be replaced. The accompanying chart shows the reduction in capacity as the forks wear.

Reprinted from Material Handling Engineering, March 1995

Copyright: 1995 Penton Publishing Inc.

Cleveland, Ohio 44114

FORKLIFT MAST SAFETY

Refer to the following illustrations for mast safety:

Safety Decals

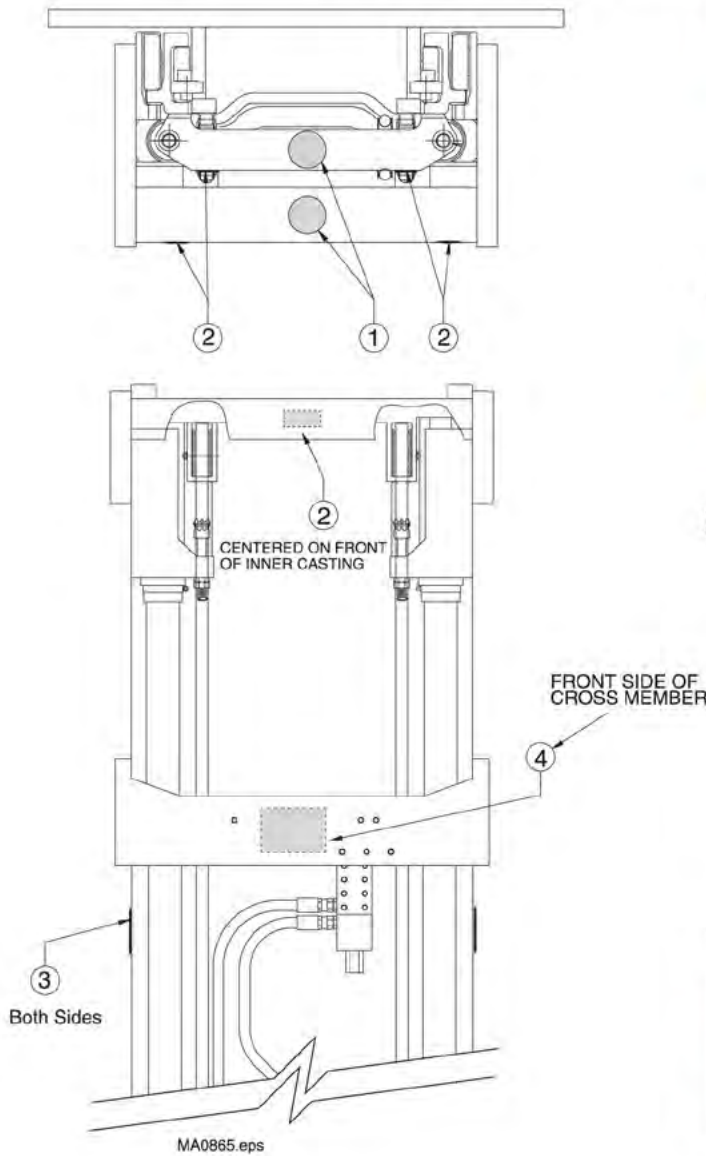

① 2 - 679150 "NO STEP"



② 5 - 665595 "HANDS OFF"



③ 2 - 224053 "FORK STOP"



④ 1 - 684166 "WARNING"



CONTROLS**INSTRUMENT PANEL DIAGRAM****INSTRUMENT PANEL INFORMATION**

1. Push button Start

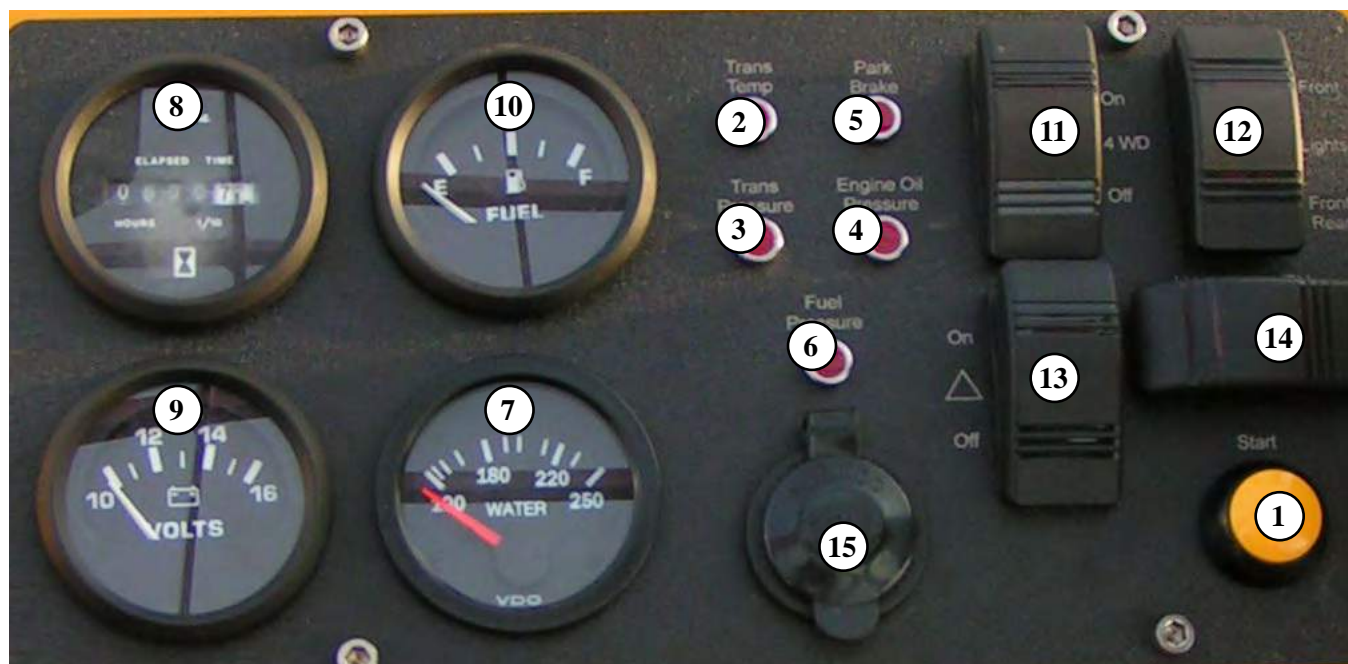

1. Push button Start

2. High Transmission Temperature Light (Red)

3. Low Transmission Oil Pressure Light (Red)

4. Low Engine Oil Pressure Light (Red)

5. Parking Brake Light (Red)

6. Engine Preheat Light (Red)

7. Engine Water Temperature Gauge

8. Hour meter Gauge

9. Voltmeter Gauge

10. Fuel Gauge

11. Four Wheel Drive Switch

12. Front and Rear Work Lights

13. Warning Lights Switch

14. Turn Signal Switch

15. 12 V Power Source

Push to start. (First, turn ignition switch clockwise to Run position.)

Indicates battery charge.

Normal readings are between 12-15 volts.

2. High Transmission Temperature Light (Red)

If this light is on, stop the engine and investigate the reason for the high transmission temperature.

10. Fuel Gauge

11. Four Wheel Drive Switch

When light is illuminated, four-wheel drive is on.

3. Low Transmission Oil Pressure Light (Red)

The warning light illuminates when the key is in the On position. After the engine starts up, the light should extinguish in seconds. Stop engine and investigate the low transmission pressure if the light does not go off.

12. Front and Rear Work Lights

When switched ahead, front lights are illuminated.

When switched back, front and rear lights are illuminated.

4. Low Engine Oil Pressure Light (Red)

The warning light illuminates when key is in the On position. After engine startup the light should extinguish in seconds. Stop engine and investigate the reason for the loss of pressure if the light does not go off.

When in the center position, lights are off.

13. Warning Lights Switch

5. Parking Brake Light (Red)

When illuminated, parking brake is engaged.

When extinguished, parking brake is disengaged.

14. Turn Signal Switch

When switched to left position, left hand lights flash.

When switched to right position, right hand lights flash.

When in the center position, the switch is off.

6. Engine Preheat Light (Red)

When illuminated, Preheat is on.

Maximum preheat time is 30 seconds.

15. 12V Power Source

7. Engine Water Temperature Gauge

Ensure engine is operating in Normal temperature zone. Stop engine if needle moves above 250° F.

Allow engine to warm up to above 160° F before operating.

8. Hour meter Gauge

Records hours of engine operation.

Observe this gauge for periodic maintenance schedules.

9. Voltmeter Gauge

VARIOUS CONTROLS

1. Optional Preheat Switch

Push to activate preheat.

Maximum time is 30 seconds.

2. Forward, Neutral, Reverse Switch FIG. 19

Center position is Neutral.

3. Horn Switch FIG. 19

Push to activate.



FIG. 19

4. Steering Wheel Adjustment FIG. 20

1 Position – Height adjustment. Pull up to extend the column.

2 Position – Angle adjustment. Push down to tilt the wheel.

DANGER – Adjustments of steering wheel must be done with the forklift stopped.

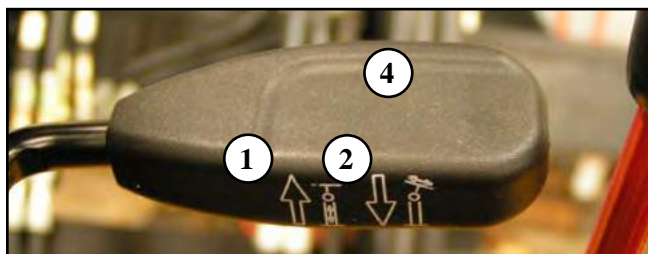

FIG. 20

5. Steering Wheel FIG. 21

Turn wheel left for left turn.

Turn wheel right for right turn.



FIG. 21

6. Lift Valve FIG. 22

A – Lift

B – Tilt

C – Side shift

D – Auxiliary

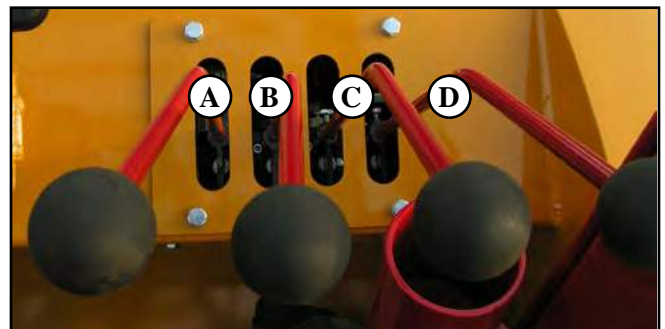

FIG. 22

7. Parking Brake FIG. 23

1 Position – Engaged

2 Position – Disengaged



Engaged FIG. 23 Disengaged

8. Brake Pedal FIG. 24

Push to apply service brakes.

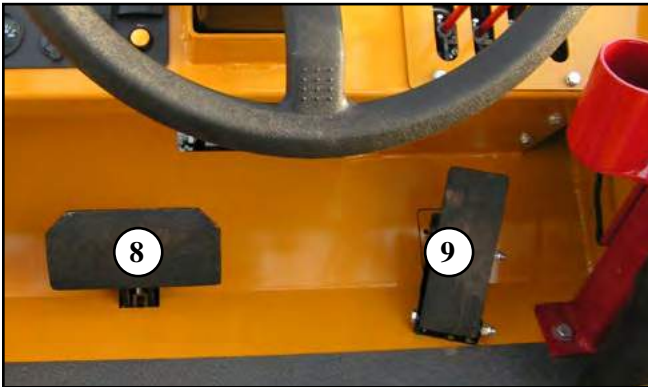

FIG. 24

9. Throttle Pedal FIG. 24

Push to increase engine speed.

10. Gear Shifter FIG. 25

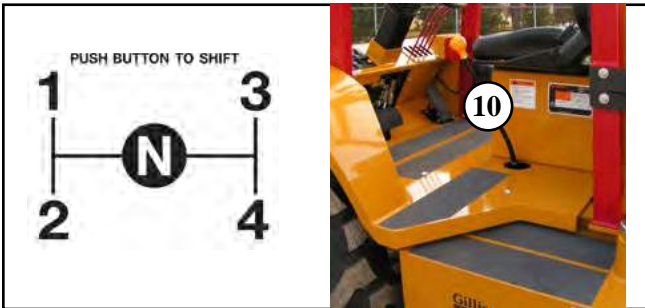

FIG. 25

11. Shift Disconnect Switch FIG. 26

Push to shift transmission.

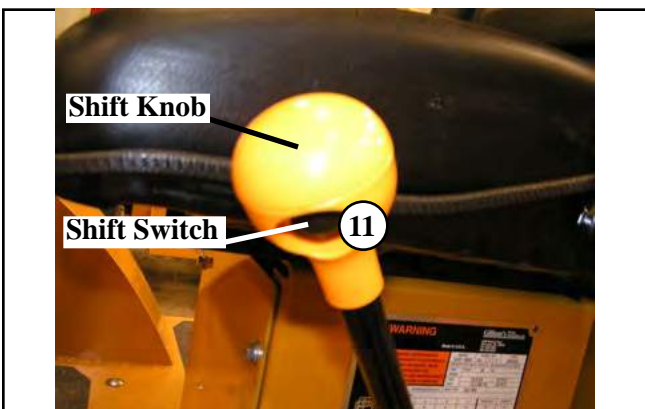

FIG. 26

12. Suspension Seat FIG. 27

A – Slide adjustment

B – Weight adjustment

Push down to increase stiffness

C – Back Rest Adjustment

D – Seat Belts



FIG. 27

13. Mirror

Adjust before operation.

14. Operator's Manual Storage FIG. 28



FIG. 28

OPERATION

(Read CONTROLS section first.)

PRE START UP

Check engine oil, transmission, hydraulic oil and radiator fluid level.

Do a walk around inspection.

STARTING THE ENGINE

Make sure parking brake is on.

Safety belt is fastened and secure.

FNR switch is in Neutral position and gear shift lever is in Neutral.

Turn ignition switch clockwise to run position then push start button.

NOTE: Max crank time = 30 seconds

Observe indicator lights and gauges to ensure everything is operating correctly.

Transmission pressure, and engine oil pressure lights go out within 15 seconds.

Engine temperature must be above 160° F before operation.

COLD WEATHER STARTING AID

FIG. 28

WARNING: Do not use ether. FIG. 28

- Turn key to run position.
- Push pre- heat button up to 30 seconds.
- Hold button in and push start button.
- Crank over until engine is running.
- Release the push buttons. If there is no start, repeat the steps.

FORKLIFT SHUTDOWN

(read CONTROLS section first)

1. Reduce engine speed to idle. Make sure forklift has come to a complete stop.
2. Move gearshift lever to Neutral.
3. Move FNR switch to Neutral.
4. Apply parking brake.
5. Lower forks to ground.
6. Allow engine to cool down for about 1 minute.
7. Turn key to Off position and remove.
8. Release all hydraulic pressure by operating mast control levers.

OPERATING GVF FORKLIFT

Learn about all controls, have knowledge of the machine and its workings, and read this manual before operating the forklift machine.

1. Make sure no obstructions are in the way.
2. Release parking brake.
3. Select a gear with the gear selector. FIG. 29
4. Raise the mast until forks are a safe distance from the ground.

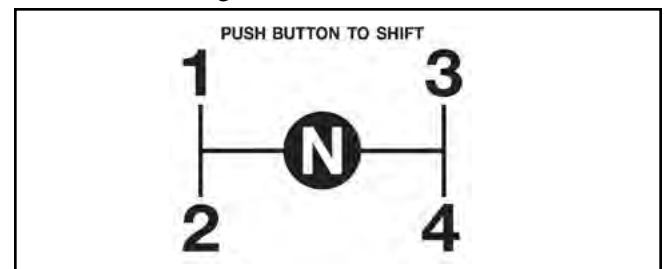
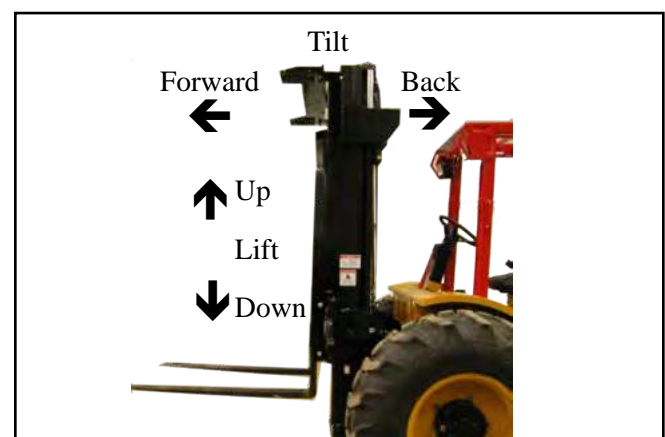
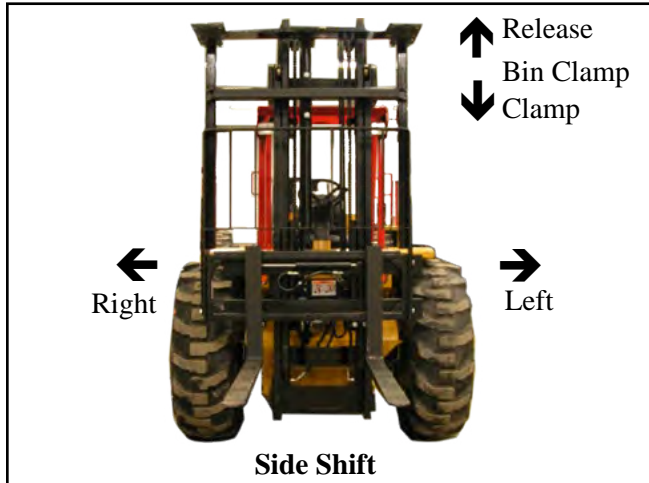

FIG. 29





7. Four Wheel Drive Operation



Engaged FIG. 23 Disengaged



Always carry loads low to ground to prevent roll over and overhead obstructions.

5. Select Forward or Reverse on FNR selector.

In Reverse, make sure back up alarm is functioning.

Check operation of brakes.

Use throttle pedal to increase engine speed and forklift speed.

Use horn when going in blind spots.

Always use Warning flashers when operating around hazards including roads. FIG. 30

Turn signals - Use on road right of ways to indicate direction turning. FIG. 30

Lights FIG. 30 - Never use rear work lights when operating on highway.

6. Operation of Parking Brake FIG. 23

On forklifts equipped with the four-wheel drive option, the four-wheel drive is engaged by switching the rocker switch. FIG. 30

The light will illuminate.

Four-wheel drive can be selected while traveling straight.

8. Fueling FIG. 31

Shut off engine.

Do NOT smoke while refueling.

Clean debris from around cap to prevent contamination.

Remove Cap.

Insert nozzle.

Fill.

Replace cap.

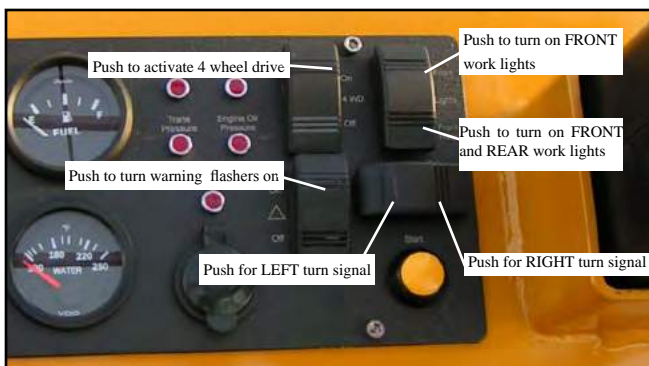

FIG. 30



Location of fuel tank

FIG. 31

LUBRICATION & MAINTENANCE

LUBRICATION & MAINTENANCE CHART

| Item | Daily | 50 hrs | 100 hrs | 500 hrs | 1000 hrs | 1500 hrs | 2000 hrs | Page in this manual |
|----------------------|-------------------------|--------|---------|---------|----------|----------|----------|---------------------|
| Tire Pressure | ✓ | | | | | | | |
| Engine | Refer to engine manual. | | | | | | | |
| Transmission | | | ✓ | ✓ | ✓ | | ✓ | 26 |
| Hydraulic Oil Level | ✓ | | | | | | | 42 |
| Suction Strainer | | | | | ✓ | | | 42 |
| Hydraulic Oil Change | | | | | ✓ | | | |
| Hydraulic Oil Filter | | | | ✓ | | | | 42 |
| Brake Fluid Level | | | ✓ | | | change | | 42 |
| Wheel Nut Torque | | | ✓ | ✓ | | | | |
| Front Axle | | | ✓ | ✓ | ✓ | | ✓ | 30 |
| Rear Axle | | | ✓ | ✓ | ✓ | | ✓ | 32 |
| Mast | ✓ | | ✓ | ✓ | | | | 38 |
| Forks | | | | | | | | 11 |
| Grease All Points | | | ✓ | | | | | below |

* First 100 hours service only to be completed by your distributor.

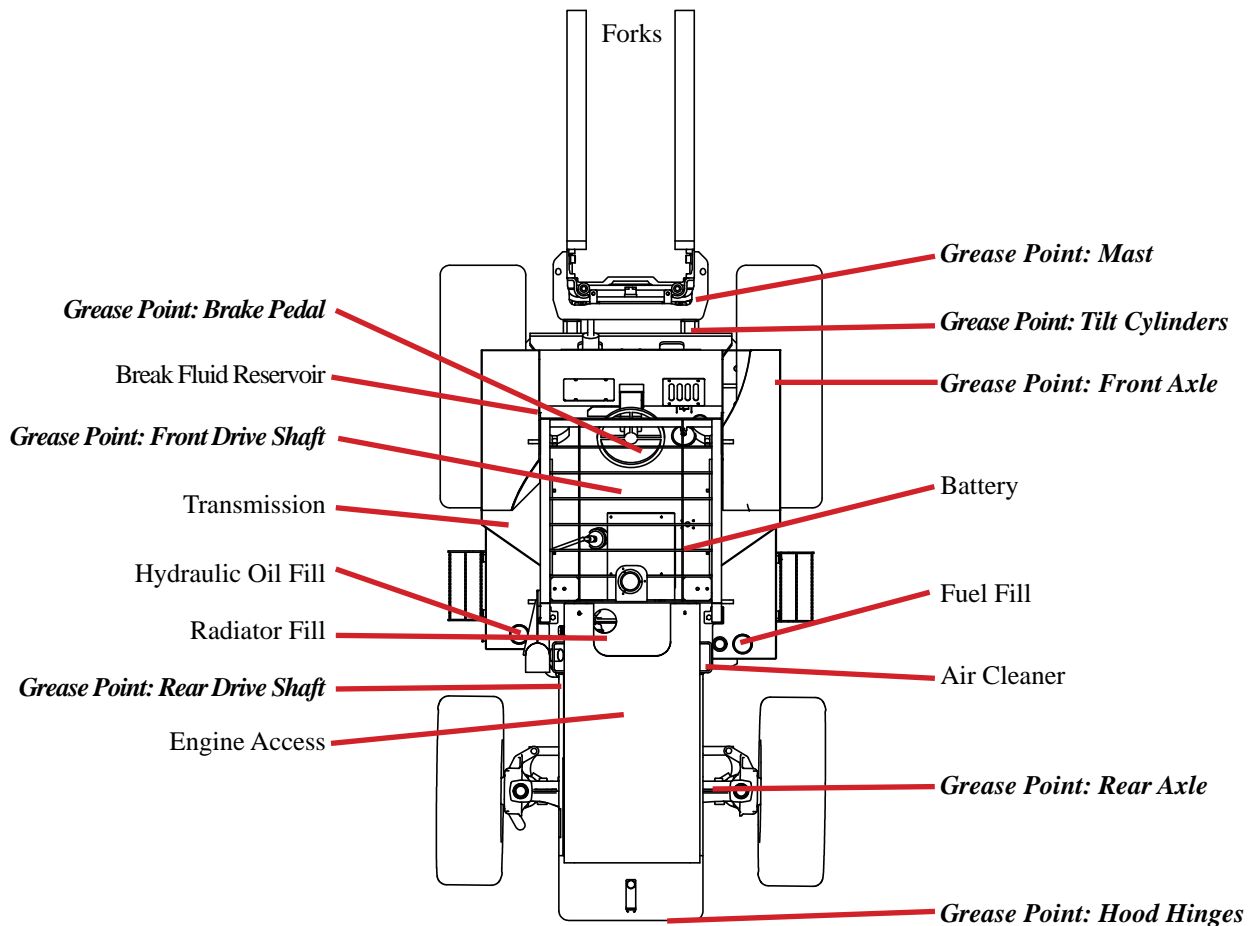

INSTRUCTIONS FOR PRESSURE WASHING

When pressure washing, protect and **DO NOT** direct the jet on the following components:

Alternator, Axle pivot pins, Radiator, Starter motor, Hydraulic oil cooler, Transmission oil cooler, Instrument panel, Electrical harness and connections, and Safety decals

ENGINE – PLEASE REFER TO THE ENGINE MANUAL.

Part Number 9801/9310

- A. Oil filter FIG. 32
- B. Engine oil dipstick FIG. 32
- C. Oil fill cap FIG. 32
- D. Oil drain plug FIG. 33

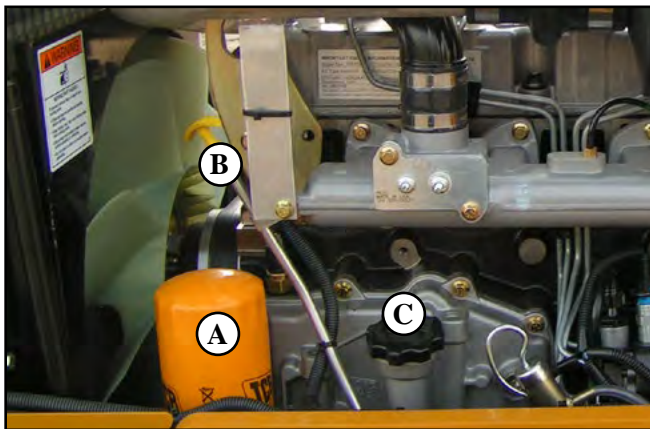

FIG. 32

E. Fuel filters FIG. 34 & 35



FIG. 33

F. Fuel lift pump FIG. 35

G. Fuel Tank FIG. 36 & 36 A

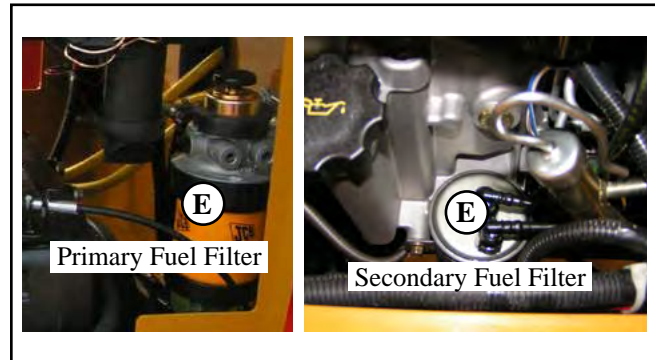

FIG. 34

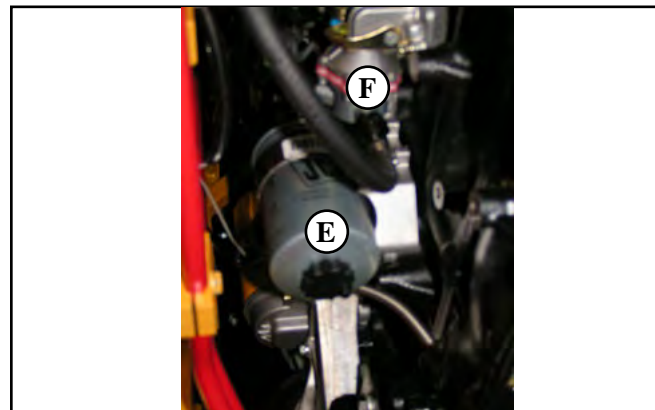

FIG. 35

H. Radiator Fill Tank FIG. 37 & 37 A

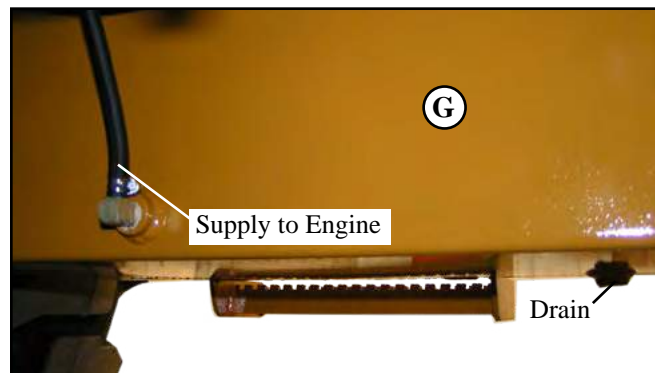

FIG. 36

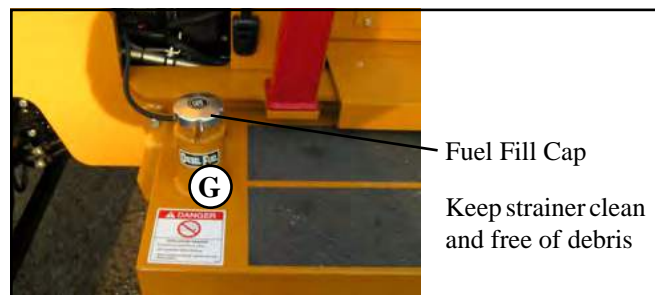

FIG. 36 A

I. Air Cleaner FIG. 38 & 39

J. Hydraulic Oil Fill FIG. 38 A

TRANSMISSION



FIG. 37



FIG. 37 A

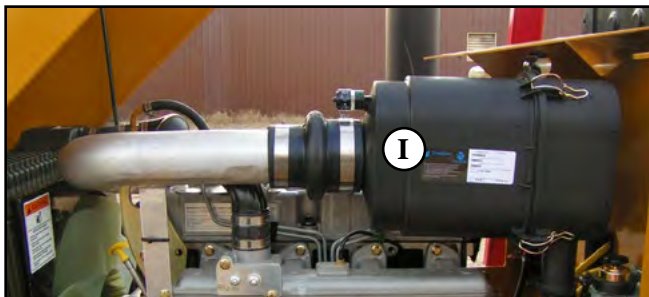

FIG. 38

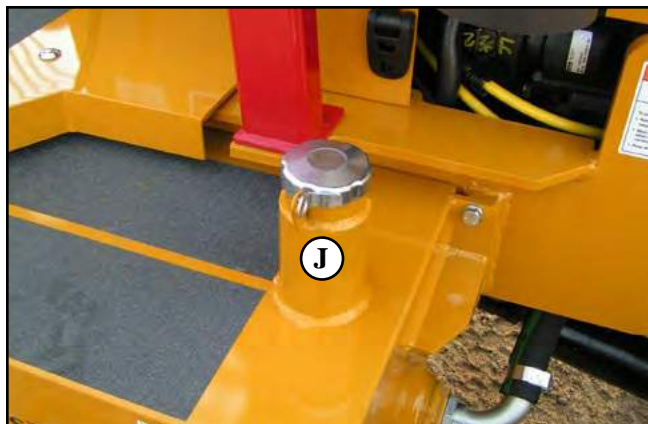

FIG. 38 A

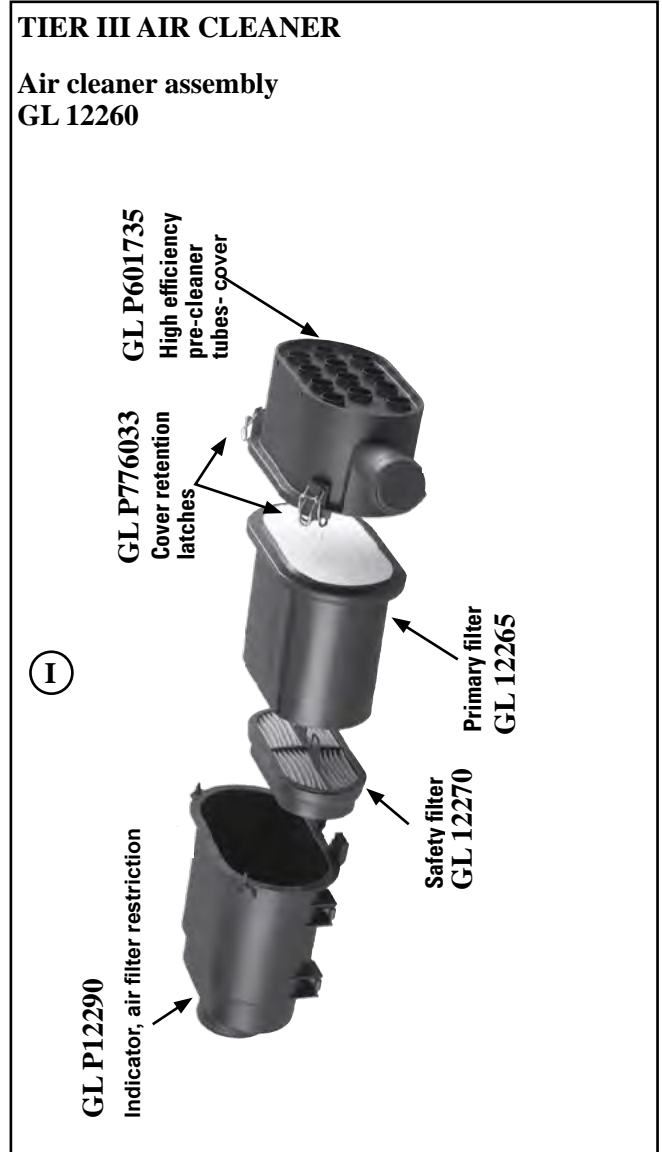

FIG. 39

Health and Safety

Hygiene

Lubricants are not a health risk when used properly for their intended purposes.

However, excessive or prolonged skin contact can remove the natural fats from your skin, causing dryness and irritation.

Low viscosity oils are more likely to do this, so take special care when handling used oils, which might be diluted with fuel contamination.

Whenever you are handling oil products you should maintain good standards of care and personal and plant hygiene. For details of these precautions we advise you to read the relevant publications issued by your local health authority, plus the following.

Storage

Always keep lubricants out of the reach of children.

Never store lubricants in open or unlabelled containers.

Waste Disposal

All waste products should be disposed of in accordance with all the relevant regulations.

The collection and disposal of used oil should be in accordance with any local regulations. Never pour used oil into sewers, drains or on the ground.

Handling

New Oil

There are no special precautions needed for the handling or use of new oil, beside the normal care and hygiene practices.

Used Oil

Used lubricants contain harmful contaminants.

Here are precautions to protect your health when handling used oil:

- 1 Avoid prolonged, excessive or repeated skin contact with used oils.

- 2 Apply a barrier cream to the skin before handling used oil.

- 3 Note the following when removing oil from skin:

- a Wash your skin thoroughly with soap and water.
- b Using a nail brush will help.
- c Use special hand cleansers to help clean dirty hands.
- d Never use petrol, diesel fuel, or paraffin for washing.

- 4 Avoid skin contact with oil soaked clothing.

- 5 Don't keep oily rags in pockets.

- 6 Wash dirty clothing before re-use.

- 7 Throw away oil-soaked shoes.

First Aid - Oil

Eyes

In the case of eye contact, flush with water for 15 minutes. If irritation persists, get medical attention.

Swallowing

If oil is swallowed do not induce vomiting. Get medical advice.

Skin

In the case of excessive skin contact, wash with soap and water.

Spillage

Absorb on sand or a locally approved brand of absorbent granules. Scrape up and remove to a chemical disposal area.

Fires

Extinguish with carbon dioxide, dry chemical or foam. Fire-fighters should use self-contained breathing apparatus.

Lubricants and Capacities - Transmission

| ITEM | CAPACITY | | | FLUID/LUBRICANT | INTERNATIONAL SPECIFICATION |
|------------------------|----------|--------|--------|------------------------------------------------------------------------------------------------------------------------------------------------------------------------------------------|-----------------------------|
| | litres | UK gal | US gal | | |
| †SS700 Gearbox (2WD) | *13.0 | 2.9 | 3.43 | Kuwait EL4117 SAE 10w | Cat TO-4 |
| †SS700 Gearbox (4WD) | *14.0 | 3.1 | 3.70 | Kuwait EL4118 SAE 30 Mobil ATF 210 | Cat TO-4 ESP-M2C 33G |
| Grease Points | -- | -- | -- | Mobil HP222 | Mobil HP222 |
| Electrical Connections | -- | -- | -- | As a corrosion and moisture inhibitor all exposed connections should be coated liberally with petroleum jelly. NB. Petroleum jelly must NOT be used on sealed-type connectors. | |

† Capacities shown with an asterisk are approximate total system and dependent on vehicle circuit. Use the maximum and minimum marks on dipstick when filling.

Transmission Oil Fill Procedure

Note: When installing a transmission in a machine, whether new or in service, it is extremely important to follow the correct oil fill procedure to prevent internal damage to the transmission.

- 1 With the engine stopped, fill the transmission with specified transmission fluid to dipstick maximum mark (see **Synchro Shuttle Transmission - Check Oil Level**).
- 2 Start the engine and run slowly for a period not exceeding five minutes. This allows the oil to fill filter, pump, torque converter, oil cooler and hoses.
- 3 Stop the engine, wait approximately one minute. Re-check the oil level and fill to dipstick level.

ITL Dipstick Details

Tube size 1" O/D x 16 S.W.G. ERW 1

Locknut and seal required for securing and sealing dipstick/filler tube - Part No. 155/10600

Filler tube must sit fully home in transmission casing counterbore.

Note: Figures given below are for transmissions installed horizontally. Allowance may be needed if installed at an angle (Front to Rear). ITL should be consulted if transmission is to be inclined in vehicle chassis.

Transmission Figures

| | | |
|-------------|-------------|--------------------------------------|
| Dimension A | 63 mm (max) | X Seal Ferrule |
| Dimension B | 88 mm (min) | Y Male nut fitting 1 1/2 in Hex. A/F |

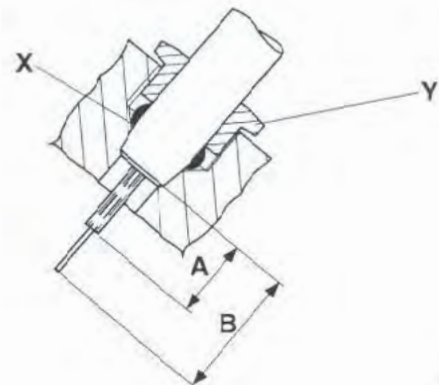

A234630

Service Schedule - Transmission

A badly maintained machine is a danger to the operator and the people working around him. Make sure that the regular maintenance and lubrication jobs listed in the service schedules are done to keep the machine in a safe and efficient working condition.

Apart from the daily jobs, the schedules are based on machine running hours. Keep a regular check on the hourmeter readings to correctly gauge service intervals. Do not use a machine which is due for a service. Make sure any defects found during the regular maintenance checks are rectified immediately.

Calendar equivalents:

- 10 Hours = Daily
- 50 Hours = Weekly
- 500 Hours = Six Months
- 1000 Hours = Yearly
- 2000 Hours = 2 Years

Service checks should be carried out as in the table at whichever time occurs first.

| Pre-start Cold Checks | Operation | 10 | 50 | †100 | 500 | 1000 | 2000 |
|----------------------------------------|-------------------|-----------|-----------|-------------|------------|-------------|-------------|
| Service Points and Fluid Levels | | Hr | Hr | Hr | Hr | Hr | Hr |
| TRANSMISSION | | | | | | | |
| Transmission Oil Level | - Check | ● | | ● | | | |
| Transmission Oil | - Change | | | | | ● | ● |
| Transmission Filter | - Change | | | ● | ● | ● | ● |
| Transmission Strainer | - Clean | | | | | ● | ● |
| Drive Shafts | - Security/Grease | | | | ● | ● | ● |

| Functional Test and Final Inspection | Operation | 10 | 50 | †100 | 500 | 1000 | 2000 |
|---------------------------------------------|------------------|-----------|-----------|-------------|------------|-------------|-------------|
| | | Hr | Hr | Hr | Hr | Hr | Hr |
| TRANSMISSION | | | | | | | |
| 2WD/4WD Selection | - Check | | | | ● | ● | ● |
| Forward/Reverse and Gear Change - Operation | - Check | | | ● | ● | ● | ● |
| Transmission Main Line Pressure †† | - Check | | | | ● | ● | ● |
| Clutch Disconnect | - Check | | | ● | ● | ● | ● |
| Neutral Start Operation | - Check | | | ● | ● | ● | ● |
| Clutch Pack Pressures †† | - Check | | | ● | ● | ● | ● |

† First 100 Hours Service only, to be completed by your Distributor.

†† Indicates jobs which should only be done by a specialist.

Synchro Shuttle Transmission

Check Oil Level

- for Interval see **Service Schedule**

A - Dipstick/Filler

Oil level should be to the full mark on the dipstick when the oil is cold i.e. before starting machine operation.

If the engine has been running, wait approximately five minutes to allow oil to drain from the torque converter before checking the oil level.

DO NOT OVERFILL

Change Oil & Clean Strainer

- for Interval see **Service Schedule**

CAUTION

When the strainer is removed, oil will gush out. Keep to one side when you remove the strainer.

2-3-4-1

Drain oil by removing strainer **B**. Clean strainer using a suitable solvent.

When refitting strainer, renew gasket **C** and apply Loctite 242 to bolts **D**.

Torque Settings

| Item | Nm | kgf m | lbf ft |
|----------|----|-------|--------|
| D | 10 | 1.0 | 7.4 |

Renew Filter

- for Interval see **Service Schedule**

- 1 Unscrew and discard element **E**.
- 2 Smear seal **F** with transmission oil, and fit new element. Note the element must be screwed on until it contacts the filter head and then tightened a minimum of $\frac{3}{4}$ turn - equal to 15 Nm (11 lbf ft) torque.
- 3 Fill system to dipstick mark with specified transmission fluid. (See **Transmission Oil Fill Procedure**.)

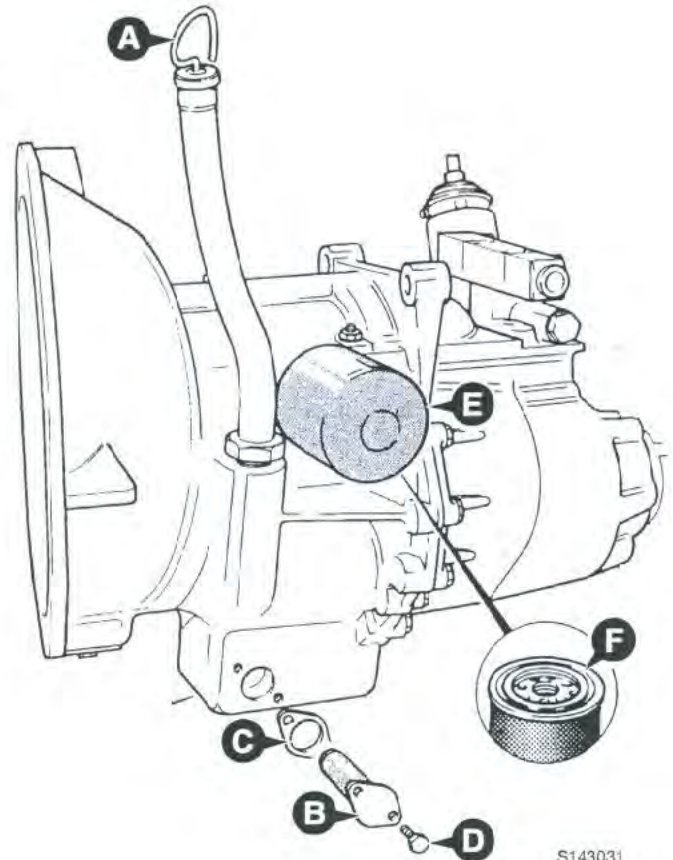

S143031

PD70 FRONT AXLE

Axle Oil Level

Check Oil Level - for Interval see Service Schedule

Note: It is essential that the machine is parked on level ground to ensure accurate oil level checking.

- 1 At the drive head casing remove fill/level plug **A**. Oil should be level with the bottom of the fill/level hole.
- 2 If necessary, top up with recommended axle oil. Clean and refit fill/level plug **A**.

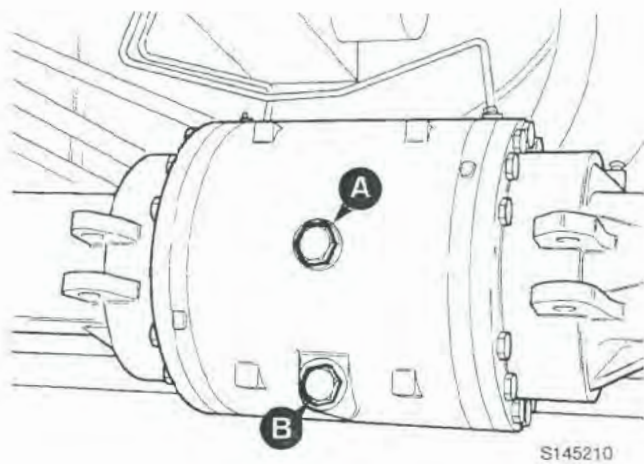

Change Oil - for Interval see Service Schedule

- 1 Set the machine level, with the machine tyres just clear of the ground. Manually rotate both wheels of the axle to bring the **OIL LEVEL** mark on the hubs to the vertical position, with the fill/level plugs **C** at the bottom.

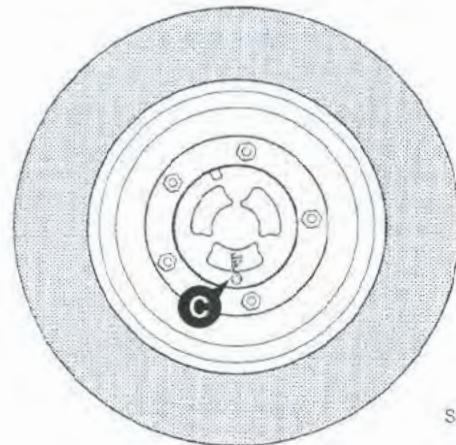

- 2 Remove fill/level plugs **C** from the hubs and drain plug **B** from the drive head casing. Allow time for the oil to drain out.
- 3 Clean and refit drain plug **B**.
- 4 Set both hub **OIL LEVEL** marks to the horizontal.
- *5 Fill the axle with the specified quantity of oil through drive head casing fill/level plug **A** (see **Lubricants and Capacities**, Section 1). If the machine has been set level, oil should just dribble out both hub fill/level points.
- 6 Clean and refit both hub fill/level plugs **C** and fill/level plug **A**.

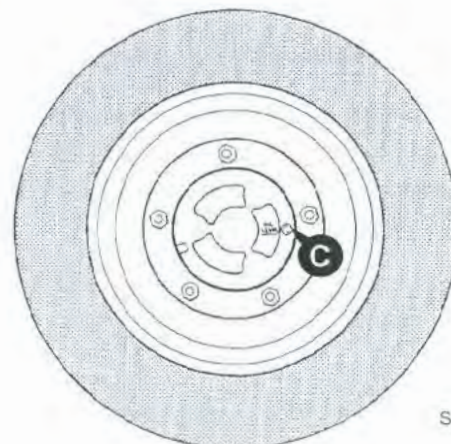

Lubricants & Capacities - Front Axle

| ITEM | CAPACITY | | FLUID/LUBRICANT | INTERNATIONAL SPECIFICATION |
|----------------|----------|--------|------------------------------|------------------------------------------------------|
| | Litres | UK Gal | | |
| * PD70 Axle | 23 | 5.0 | Mobil 424, Q8 T2000 | API GL4, M2C-41B/134D JD20C, MF M1135/M1141/M1143 |
| * Grease | - | - | Mobil HP222, Q8 Rubens EP2.5 | Mobil HP222 |
| * Brake System | 1.2 | 0.26 | Mobil DTE11M, Q8 Handel 15 | ISO VG15 |

CAUTION: DO NOT USE ORDINARY BRAKE FLUID (J1703)

Note 1: Mobil 424 should always be used for axles fitted with brakes. For axles without brakes Mobilube HD90 or Mobil Fluid 424 can be used.

Note 2: Axles with limited slip differentials must use Mobil Fluid 424.

Service Schedules - Front Axle

A badly maintained axle is a danger to the operator and the people working around him. Make sure that the regular maintenance and lubrication jobs listed in the service schedules are done to keep the axle in a safe and efficient working condition.

The schedules are based on machine running hours. Do not use a machine which is due for a service. Make sure any defects found during the regular maintenance checks are rectified immediately.

Calendar equivalents:

50 Hours = Weekly

500 Hours = Six Months

1000 Hours = Yearly

2000 Hours = 2 Years Service checks should be carried out as in the table at whichever time occurs first.

| Service Points and Fluid Levels | Operation | 10 | 50 | †100 | 500 | 1000 | 2000 |
|-----------------------------------------------|-----------|----|----|------|-----|------|------|
| | | Hr | Hr | Hr | Hr | Hr | Hr |
| Axle Oil Level (incl. Hubs when applicable) ① | - Check | | | • | • | • | • |
| * Axle Oil (incl. Hubs when applicable) | - Change | | | | •② | • | • |
| Tightness of mounting bolts | - Check | | | | • | • | • |

† **Note:** First 100 Hours Service only.

① **Note:** Check for leaks every 50 hours, check level if leaking.

* ② **Note:** Limited Slip Differential and Differential Lock only.

Note: Faults in the braking system must be rectified **immediately**. Ensure the correct brake fluid is used (see **Lubricants and Capacities**, Section 1) and all equipment is clean and free from water contamination. Under no circumstances should water be allowed to enter the braking system.

SD55 REAR AXLE

Drive head Axles

Checking the Differential Oil Level

⚠ WARNING

Make the machine safe before getting beneath it. Lower the attachments to the ground; engage the parking brake; remove the starter key, disconnect the battery.

2-3-2-2

⚠ CAUTION

The axle oil level must be checked with the machine level, otherwise a false indication of the amount of oil in the axle will be given.

16-3-5-3

- 1 Park the machine on level ground. Engage the parking brake. Set the transmission to neutral. Lower the attachments to the ground. Stop the engine and remove the starter key.
- 2 Clean the area around the fill/level plug **A**, then remove the plug and its sealing washer. Oil should be level with the bottom of the hole. Add recommended oil, if necessary. See **Lubricants and Capacities** for recommended oil. Clean the plug and sealing washer before refitting them.

Changing the Differential Oil

The axle oil is used to lubricate the brake components and cool the brake plates.

It is important that the oil is changed regularly as specified in the service schedule - the lubricating properties of the oil will reduce as a result of brake wear.

Consult your OEM for advice if necessary.

⚠ WARNING

Make the machine safe before getting beneath it. Lower the attachments to the ground; engage the parking brake; remove the starter key, disconnect the battery.

2 3 2 2

- 1 Park the machine on level ground. Engage the parking brake. Set the transmission to neutral. Lower the attachments to the ground. Stop the engine and remove the starter key.
- 2 Place a container of suitable size beneath plug **B** to catch the oil. See **Lubricants and Capacities**. Remove fill/level plug **A** and drain plug **B**, together with their bonded washers. Allow time for the oil to drain out. Clean and refit drain plug **B** and a new bonded washer. Tighten to 79 Nm (58 lbf ft).
- 3 Fill the axle with recommended axle oil through the fill/level hole **A**. Oil should be level with the bottom of the fill/level hole. See **Lubricants and Capacities**. Clean and refit fill/level plug **A** and a new bonded washer.

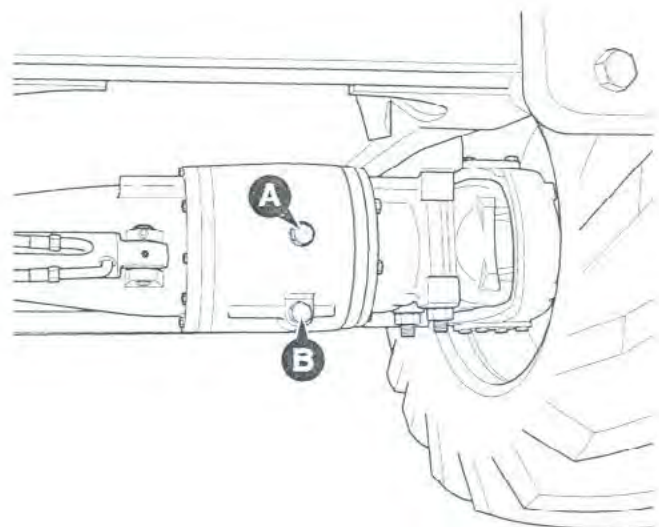

Drive head Axles Cont. - Rear Axle

Checking the Hub Oil Levels

Check each hub separately.

- 1 Park the machine on level ground with the **OIL LEVEL** mark horizontal. There is a tolerance of 5 mm (0.2 in) above or below the horizontal.

Engage the parking brake. Set the transmission to neutral. Lower the attachments to the ground. Stop the engine and remove the starter key.

- 2 Clean the area around the fill/level plug **C**. Remove the plug. Oil should be level with the bottom of the hole. If necessary, add recommended oil. See **Lubricants and Capacities** for recommended oil. Clean the plug before refitting it.

Changing the Hub Oil

- 1 Set the machine level, with the tyres just clear of the ground. Manually rotate the wheels to bring the **OIL LEVEL** mark on the hubs to the vertical position, with the fill/level plugs **C** at the bottom.

- 2 Place a container of suitable size beneath plug **C** to catch the oil. See **Lubricants and Capacities**.

Remove fill/level plugs **C**. Allow time for the oil to drain out.

- 3 Set **OIL LEVEL** marks to the horizontal. There is a tolerance of 5 mm (0.2 in) above or below the horizontal.

Fill the hubs with recommended axle oil, through the fill/level holes **C**. See **Lubricants and Capacities**. Oil should be level with the bottom of the fill/level hole.

- 4 Clean and refit fill/level plugs **C**.

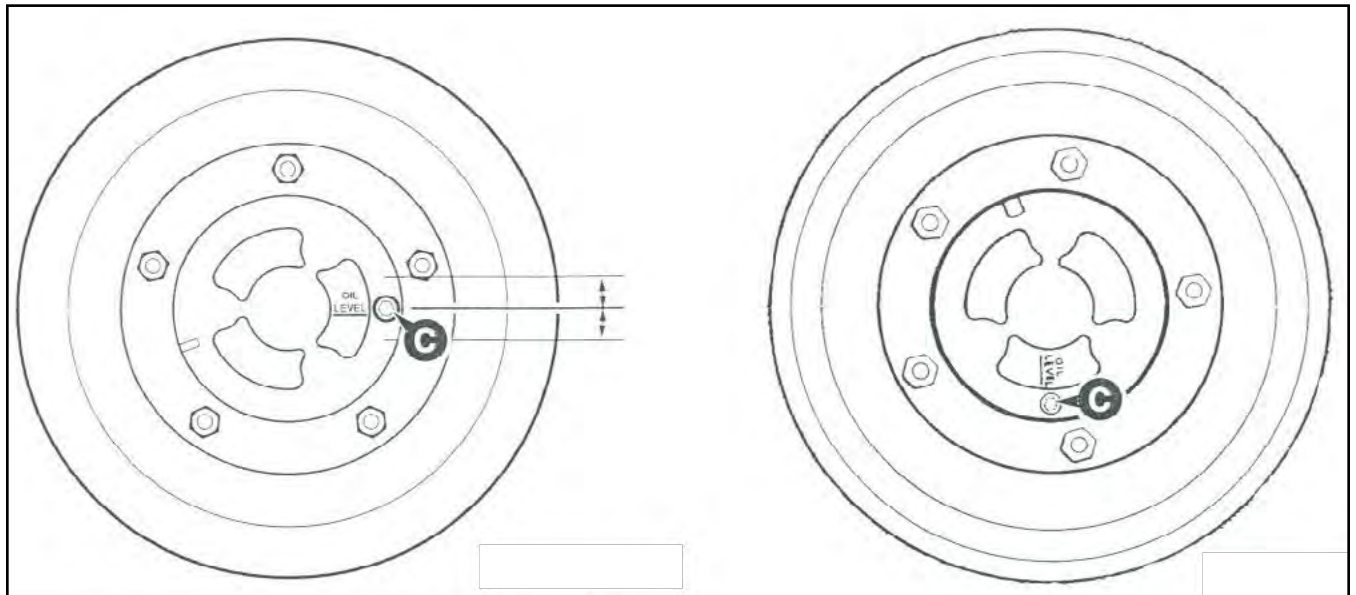

Greasing Axles - Rear Axle

Note: When greasing, raise the wheels and swing them from lock to lock. This will ensure full penetration.

Total 8 Grease Points.

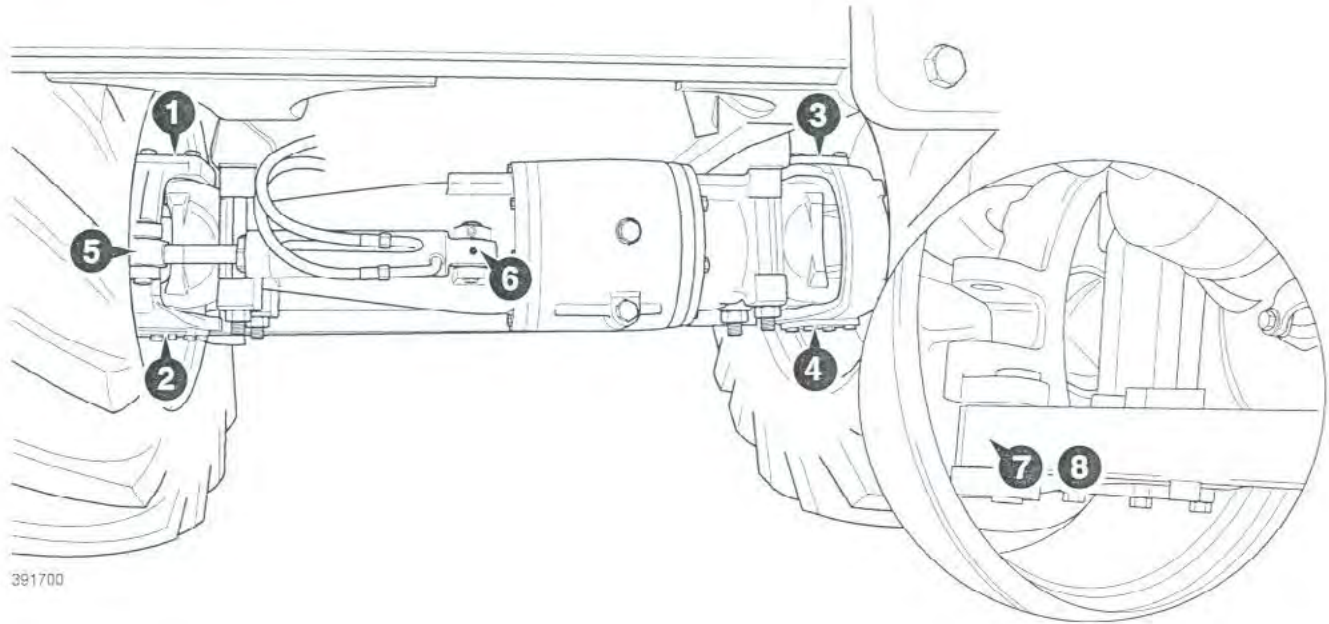

391700

Health & Safety - Rear Axle

Hygiene

Lubricants are not a health risk when used properly for their intended purposes.

However, excessive or prolonged skin contact can remove the natural fats from your skin, causing dryness and irritation.

Low viscosity oils are more likely to do this, so take special care when handling used oils, which might be diluted with fuel contamination.

Whenever you are handling oil products you should maintain good standards of care and personal and plant hygiene. For details of these precautions we advise you to read the relevant publications issued by your local health authority, plus the following.

Storage

Always keep lubricants out of the reach of children.

Never store lubricants in open or unlabelled containers.

Waste Disposal

All waste products should be disposed of in accordance with all the relevant regulations.

The collection and disposal of used oil should be in accordance with any local regulations. Never pour used oil into sewers, drains or on the ground.

Handling

New Oil

There are no special precautions needed for the handling or use of new oil, beside the normal care and hygiene practices.

Used Oil

Used lubricants contain harmful contaminants.

Here are precautions to protect your health when handling used oil:

- 1 Avoid prolonged, excessive or repeated skin contact with used oils.

- 2 Apply a barrier cream to the skin before handling used oil.
- 3 Note the following when removing oil from skin:
 - a Wash your skin thoroughly with soap and water.
 - b Using a nail brush will help.
 - c Use special hand cleansers to help clean dirty hands.
 - d Never use petrol, diesel fuel, or paraffin for washing.
- 4 Avoid skin contact with oil soaked clothing.
- 5 Don't keep oily rags in pockets.
- 6 Wash dirty clothing before re-use.
- 7 Throw away oil-soaked shoes.

First Aid - Oil

Eyes

In the case of eye contact, flush with water for 15 minutes. If irritation persists, get medical attention.

Swallowing

If oil is swallowed do not induce vomiting. Get medical advice.

Skin

In the case of excessive skin contact, wash with soap and water.

Spillage

Absorb on sand or a locally approved brand of absorbent granules. Scrape up and remove to a chemical disposal area.

Fires

Extinguish with carbon dioxide, dry chemical or foam. Fire-fighters should use self-contained breathing apparatus.

Lubricants & Capacities - Rear Axle

| ITEM | CAPACITY | | FLUID/LUBRICANT | INTERNATIONAL SPECIFICATION |
|---------------|----------|---------|---------------------------------------------------------------------------|---------------------------------------------------------------------|
| | Litres | UK Gals | | |
| Axle - SD 55 | | | | |
| Housing | 15.5 | 3.4 | Mobil Fluid 424, Q8 EL3857 | Q8EL3857 API-GL-4, M2C-41B/134D JD20C MF M1135/M1141/M1143 |
| Hubs (x2) | 0.9 | 0.2 | | |
| Grease Points | - | - | Mobil HP222 | Mobil HP222 |
| Brake System | | | Mobil DTE 11M CAUTION: Do not use ordinary brake fluid (J 1703) | ISO VG 15 |

Service Schedules - Rear Axle

A badly maintained machine is a danger to the operator and the people working around him. Make sure that the regular maintenance and lubrication jobs listed in the service schedules are done to keep the machine in a safe and efficient working condition.

 WARNING

A raised and badly supported machine can fall on you. Position the machine on a firm, level surface before raising one end. Ensure the other end is securely chocked. Do not rely solely on the machine hydraulics or jacks to support the machine when working under it.

Disconnect the battery, to prevent the engine being started while you are beneath the machine.

GEN-1-1

Apart from the daily jobs, the schedules are based on machine running hours. Keep a regular check on the hourmeter readings to correctly gauge service intervals. Do not use a machine which is due for a service. Make sure any defects found during the regular maintenance checks are rectified immediately.

Calendar equivalents:

- 10 Hours = Daily
- 50 Hours = Weekly
- 500 Hours = Six Months
- 1000 Hours = Yearly
- 2000 Hours = 2 Years

Service Schedules Cont. - Rear Axle

Service checks should be carried out as in the table at whichever time occurs first.

| Pre-start Cold Checks Service Points and Fluid Levels | Operation | 10 Hr | 50 Hr | †100 Hr | 500 Hr | 1000 Hr | 2000 Hr |
|----------------------------------------------------------|-----------|----------|----------|------------|-----------|------------|------------|
| AXLES AND STEERING | | | | | | | |
| Axle Hub Oil Level ① | - Check | | | • | • | • | • |
| Axle Hub Oil | - Change | | | | | • | • |
| Centre Case Oil Level | - Check | | | • | • | | |
| Centre Case Oil | - Change | | | | | • | • |
| Steer Axle Movement/Shimming ② | - Check | | | • | • | • | • |
| Axle Steering Joints †† | - Grease | | | • | • | • | • |
| HYDRAULICS | | | | | | | |
| Cylinders - Chrome Condition | - Check | | | | • | • | • |
| Functional Test and Final Inspection | Operation | 10 Hr | 50 Hr | †100 Hr | 500 Hr | 1000 Hr | 2000 Hr |
| AXLES AND STEERING | | | | | | | |
| Steering Modes - Operation | - Check | • | • | • | • | • | • |
| Steering Proximity Switch - Operation ② | - Check | | | • | • | • | • |
| Wheel Nut Torque | - Check | • | • | • | • | • | • |
| Steer Phasing ② | - Check | | | | • | • | • |
| Steer Cylinder - Balance ② | - Check | | | • | • | • | • |
| Steer Circuit Pressure ② | - Check | | | • | • | • | • |

† **Note:** First 100 Hours Service only, to be completed by your Distributor.

†† **Note:** Mobil HP222 Grease must be used at 500 Hour intervals. If an alternative grease is used, the Service Intervals must be reduced to 50 hours/weekly.

① **Note:** Check for leaks every 50 hours, check level if leaking.

② **Note:** Jobs which should only be done by a specialist are indicated by a ②.

Note: Check generally for leaks on ALL systems, for example, hydraulics, axles etc. If a leak is evident find the source and repair as required. Make sure that the system is topped up with the recommended fluid after repair.

Note: Faults in the braking system must be rectified **immediately**. Ensure the correct brake fluid is used (see **Lubricants and Capacities**), and all equipment is clean and free from water contamination. Under no circumstances should water be allowed to enter the braking system.

MAST MAINTENANCE

Periodic Maintenance

For proper operation and an extended service life, your Lift Tek Mast should be inspected and serviced regularly as part of your normal lift truck maintenance schedule according to the following outlines and ANSI B56.1 procedures. The recommended intervals are for masts operating under normal conditions. If the mast is operating in severe conditions or corrosive atmospheres, the inspections should be performed more frequently.



WARNING: Never work on the mast with a load on the forks or attachment, in the raised position without supports or while anyone is near the lift truck control handles per ANSI B56.1

Daily Inspection

Perform the following at the beginning of each work shift:

1. Extend the carriage a few inches off the ground and make sure the chains are under equal tension. Refer to Section 5.6-3 for chain adjustment.
2. Extend the mast to its fullest height to make sure the mast rails and carriage extend freely without binding.
3. While the mast is extended, inspect the upright rails for proper lubrication. Refer to Section 2.5-3 Step for rail lubrication.
4. Make sure the internal reeving hoses (if equipped) travel evenly in the hose guides. Adjust the hose ends if required. Tighten the fittings making sure they do not twist.

100 Hour Inspection

After each 100 hours of lift truck operation, and in addition to the daily inspection:

1. Inspect and lubricate the full length of the chains with SAE 40 wt. oil or Bowman Heavy Load Red Grease.

CAUTION: The chains must be coated with a film of lubricant at all times.

500 Hour Inspection

After each 500 hours of lift truck operation, and in addition to the Daily and 100 Hour Inspection:

1. Each pair of load rollers on the uprights and carriage should be shimmed so that a total side to side clearance no greater than 1/16 in. (1.5 mm) occurs at the tightest point throughout the travel of the member. Pry between the upright and load roller so that the opposite load roller is tight against the upright. Measure the clearance for the pair of rollers at XXX shown. See Figure 14.
2. Check the chains for wear and stretch. Refer to Section 5.6-1 for complete chain inspection.

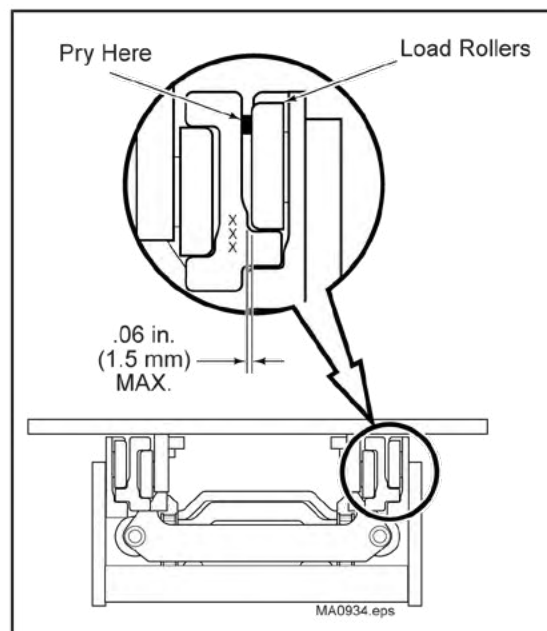

Figure 14. Load Roller Clearances.

Mast maintenance cont.

Carriage Inspection

1. Inspect the rollers for excessive wear or damage. Rollers with visible flat spots or cracks should be replaced.
2. Inspect the roller bearings by turning the rollers on their shafts. Rollers with roughness or noticeable restrictions to turning should be replaced.
3. Inspect all welds between the carriage side plates and the carriage fork bars. If any welds are cracked, replace the carriage.
4. Inspect the roller stub shafts. If they are damaged or if there are cracks at the base of the stub shafts, the carriage must be replaced or repaired. Contact Lift Tek for repair procedures.

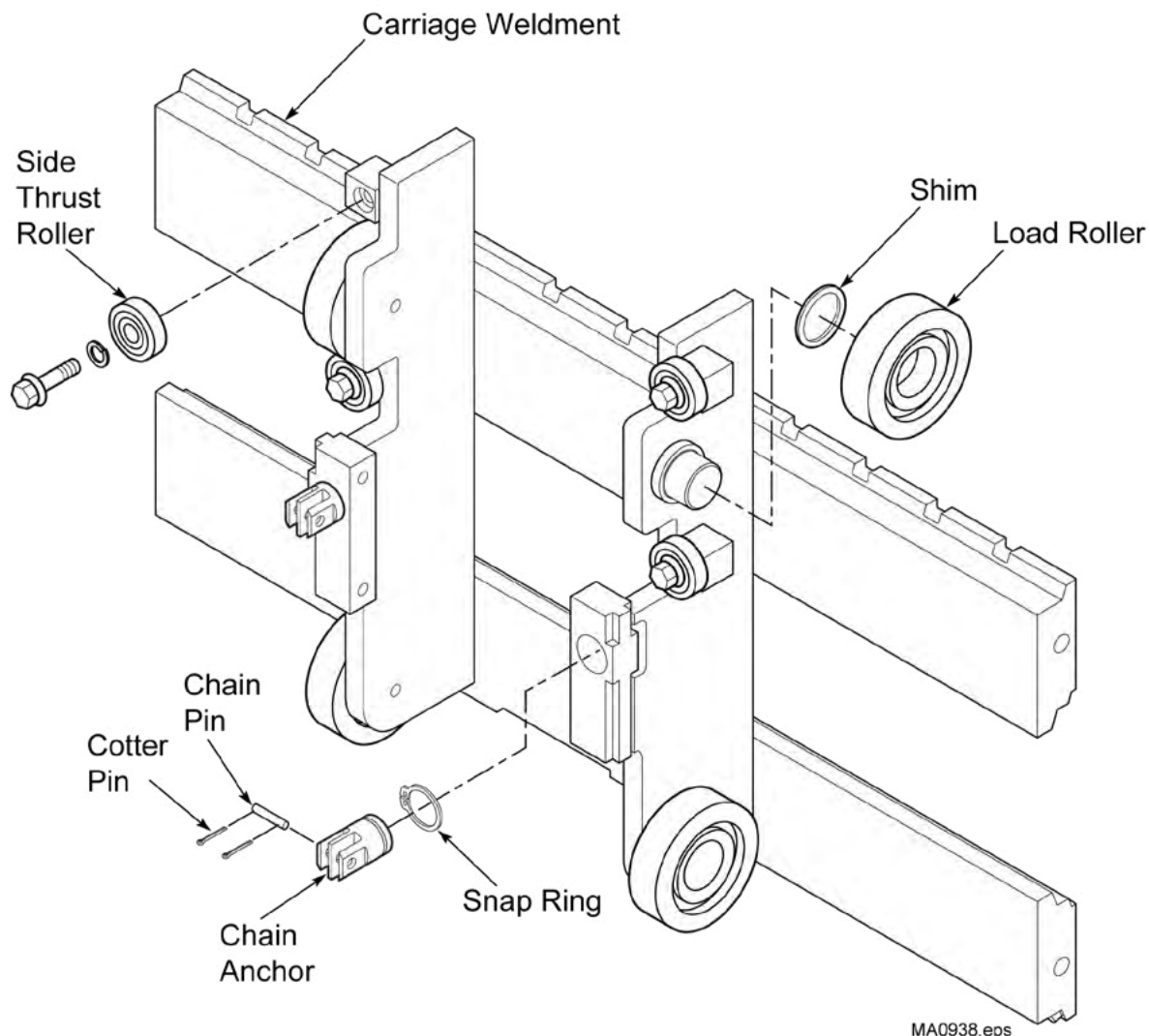

Figure 30. Carriage Service.

Mast maintenance cont.

Chains

Inspection and Tension

Each pair of chains has been factory-lubricated using heat and pressure to force the lubricant thoroughly into the chain links. Avoid removal or contamination of this factory applied lubricant. **Do not wash, sand blast, etch, steam clean, or paint the chains on initial mast installation.**

The chains must be adjusted with equal tension to ensure proper load distribution and mast operation. To determine equal tension, extend the unloaded mast to put the chains under tension. Press the center of a strand of chain with your thumb, then press at the same place on the other chain of the pair. Each chain in a pair should have equal "give". If tension is not equal, adjust the chains as described in **Chain Adjustment**.

Inspect the chains. If inspection reveals that one strand of a pair of chains requires replacement, **both** strands of the pair should be replaced.

*Check for rust and corrosion.

*Check for cracked side plates. If you find cracked side plates, replace **both** strands of chain.

*Check for tight joints. If tight joints are caused by rust or corrosion, loosen them with SAE 40 wt. oil or penetrating oil. If they cannot be loosened, or if the tight joints are caused by bent pins or plates or by peened plate edge, replace **both** strands of the chain.

*Check for protruding or turned pins. Replace **both** strands of the chain.

*Check for chain side wear. If pins and outside plates show signs of wear, check for misalignment of sheaves, anchors or other components. Correct the misalignment. If wear is excessive, replace **both** strands of chain.

*Check for worn, broken or misaligned chain anchors. Replace or adjust as required.

*Lubricate the full length of the chains with SAE 40 wt. oil or Bowman Heavy Load Red Grease.

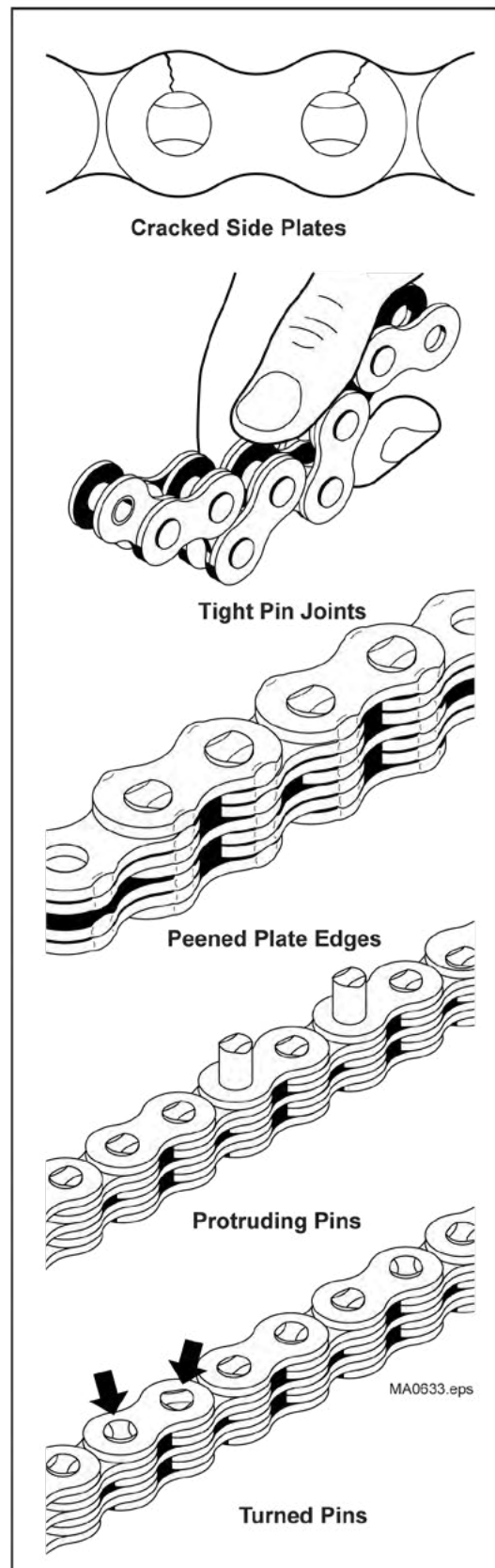

Figure 42.Chain Inspection.

Mast maintenance cont.

Measuring Chain Stretch

Regular inspection and lubrication of the chains will increase their service life and reduce downtime.

If the chains stretch beyond the recommended amount, they should be replaced in pairs. Chain stretch can be measured with chain wear scale. Measure the chains according to the instructions printed on the chain wear scale, without a load on the carriage.

*To check the free lift chains, raise the carriage 1 ft. (30 cm) off the ground to put tension on the chains.

*To check the main lift chains, raise the mast until the inner upright starts to extend putting tension on the chains.

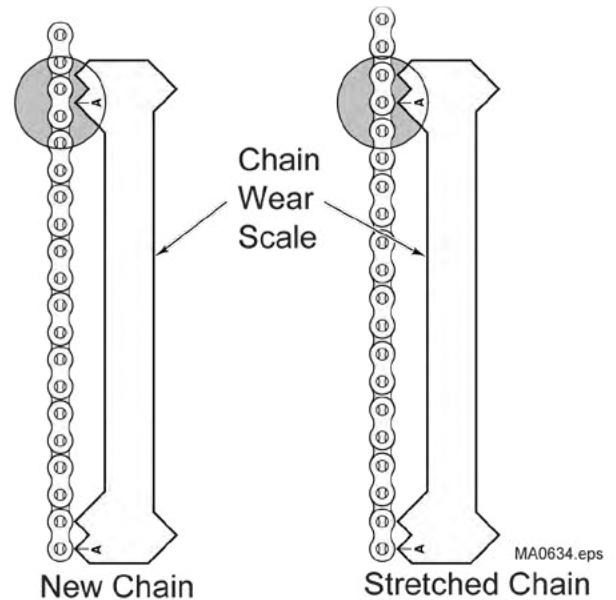

Figure 43. Measuring Chain Stretch.

Main Lift Chain Adjustment

The main lift chains should be adjusted so that when the unloaded mast is fully lowered, the uprights are positioned as shown in figure 44.

1. Adjust one chain to achieve the correct upright position when fully lowered. See Figure 45.
2. Adjust the other chain to achieve equal chain tension. Tighten the nuts together to a torque of 50-70 ft.-lbs. (98-96 Nm).
3. Raise and lower the mast several times to confirm the adjustments.

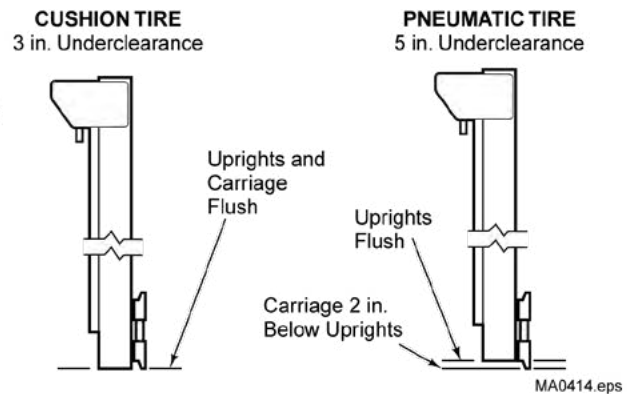

Figure 44. Upright and Carriage Position.

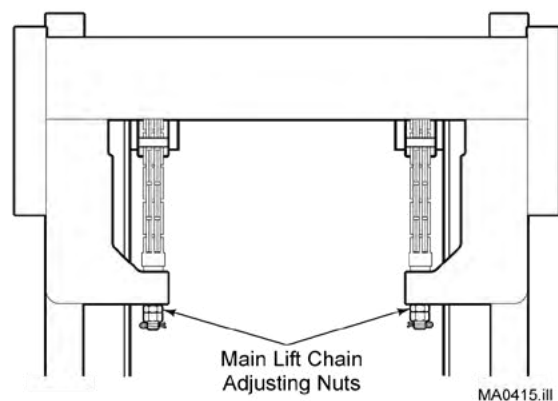

Figure 45. Main Lift Chains.

BRAKE FLUID

- Check level every 100 hours
- Change fluid every 1500 hours
- Use Brake Fluid Mobile 424

see FIG. 40



FIG. 40

- Change hydraulic oil filter every 500 hours
FIG. 42

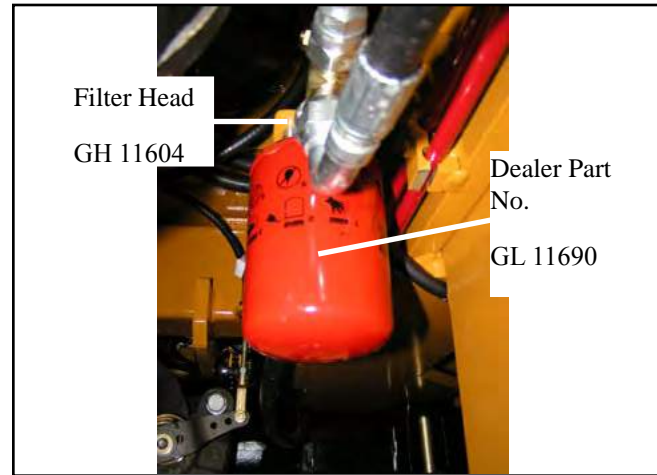

FIG. 42

HYDRAULIC SYSTEM

- Check hydraulic oil level daily FIG. 41



FIG. 41

- Change hydraulic oil every 1000 hours FIG. 43
- Clean suction strainer every 1000 hours



FIG. 43

Hydraulic Diagram

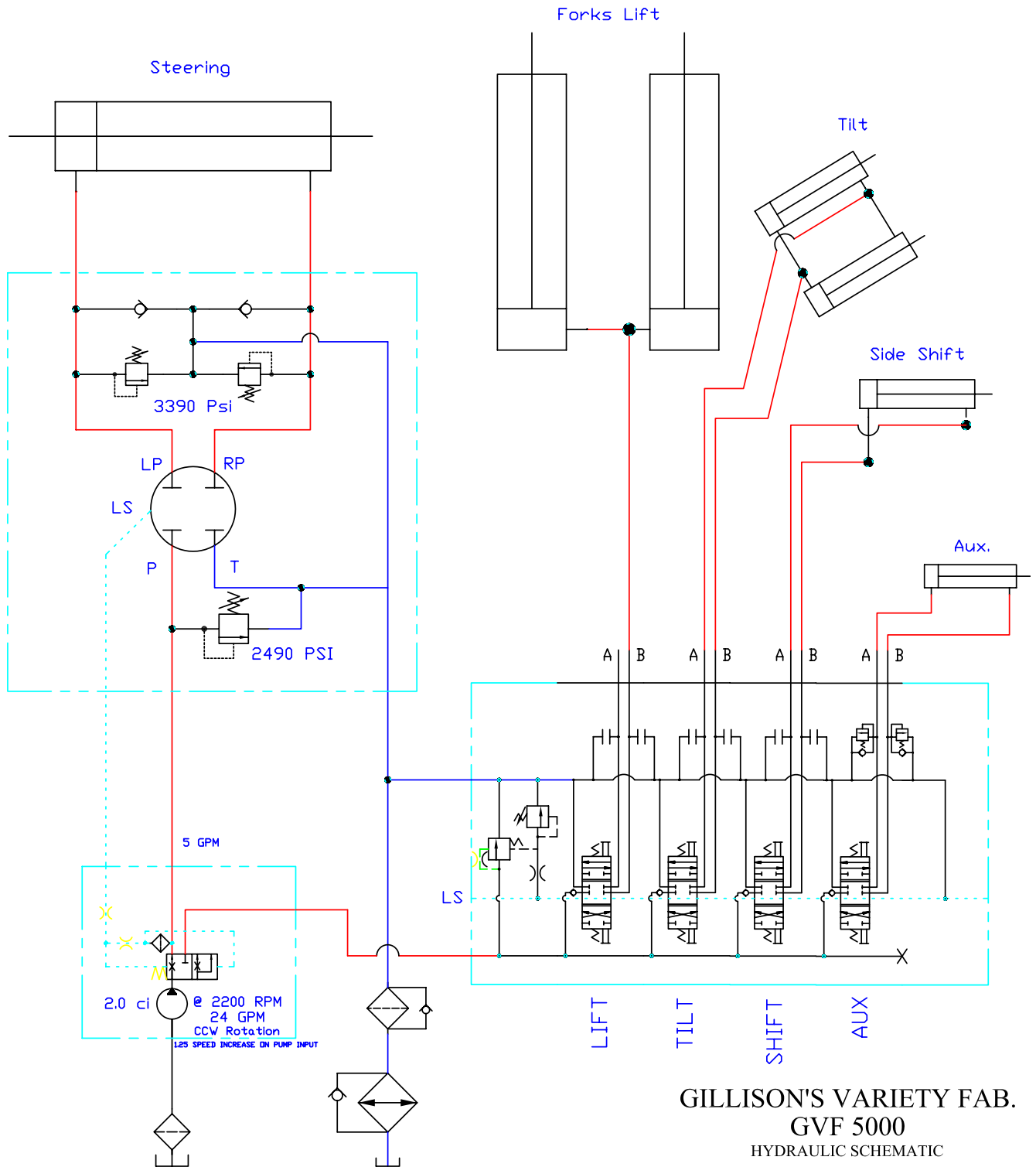

ELECTRICAL

Battery

FUSES SEE FIG. 44

SEE FIG. 45 & FIG.12



FIG. 44



FIG. 45

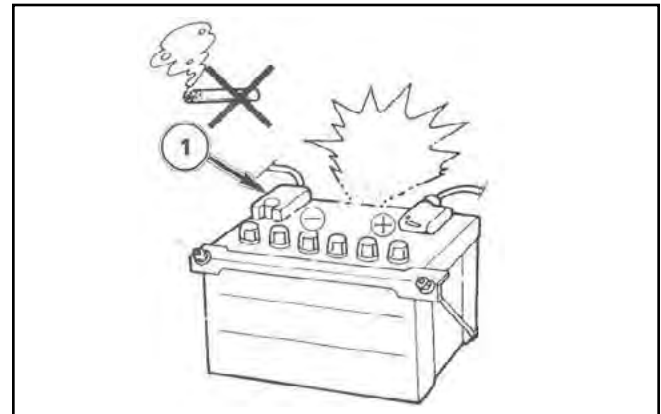
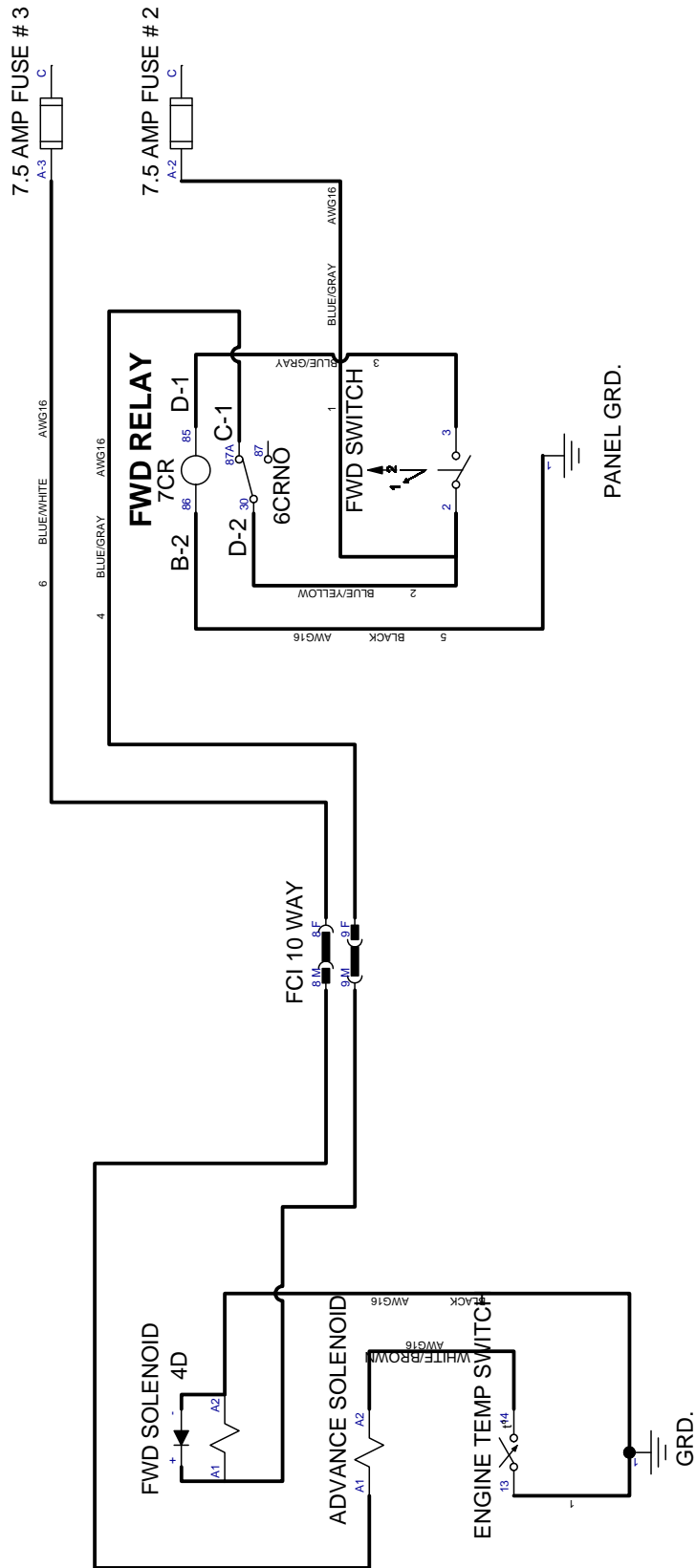
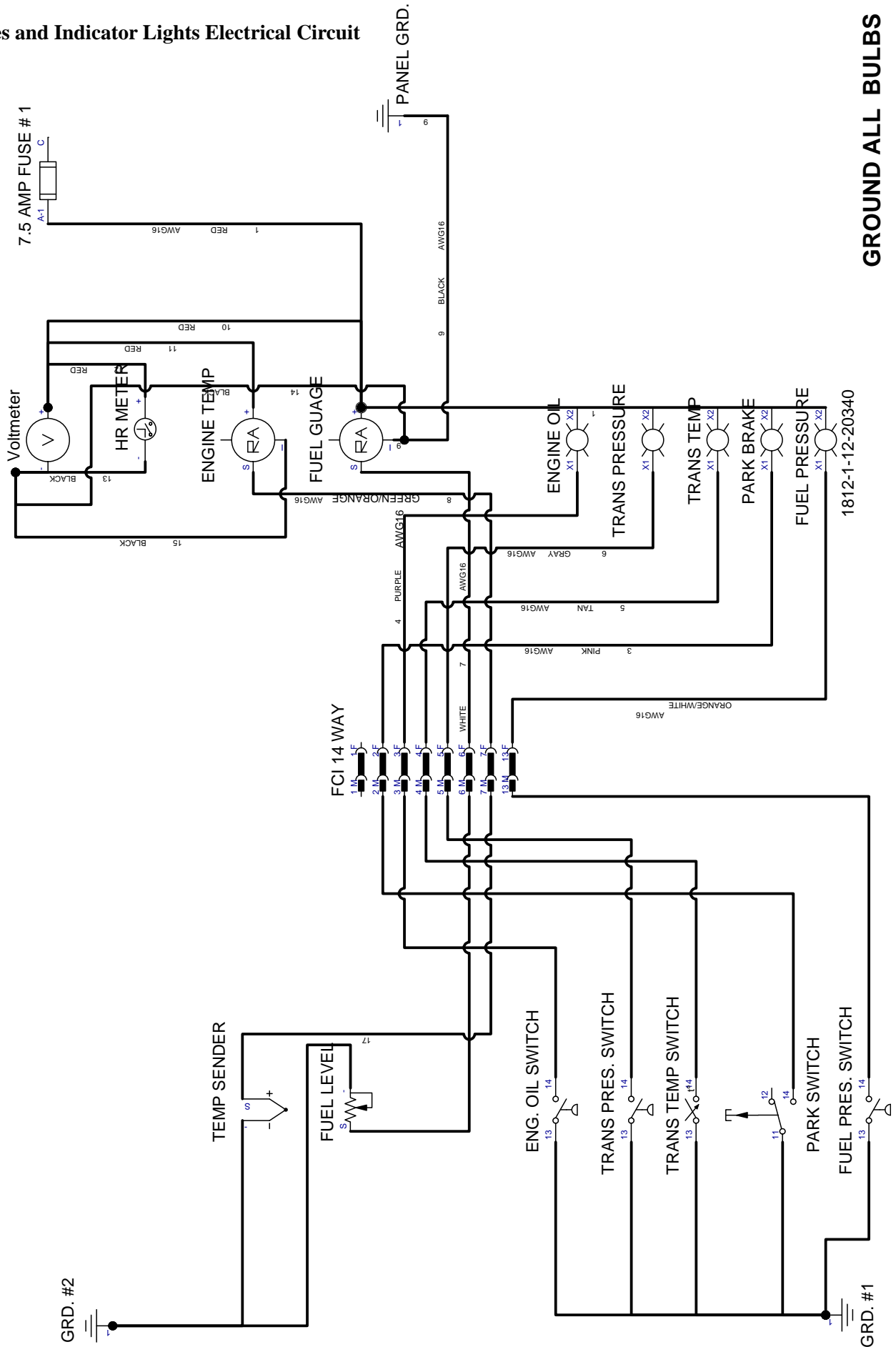

FIG. 12

4 WD and Timing Advance Electrical Circuit



Gauges and Indicator Lights Electrical Circuit



Front and Rear Work Lights

Electrical Circuit

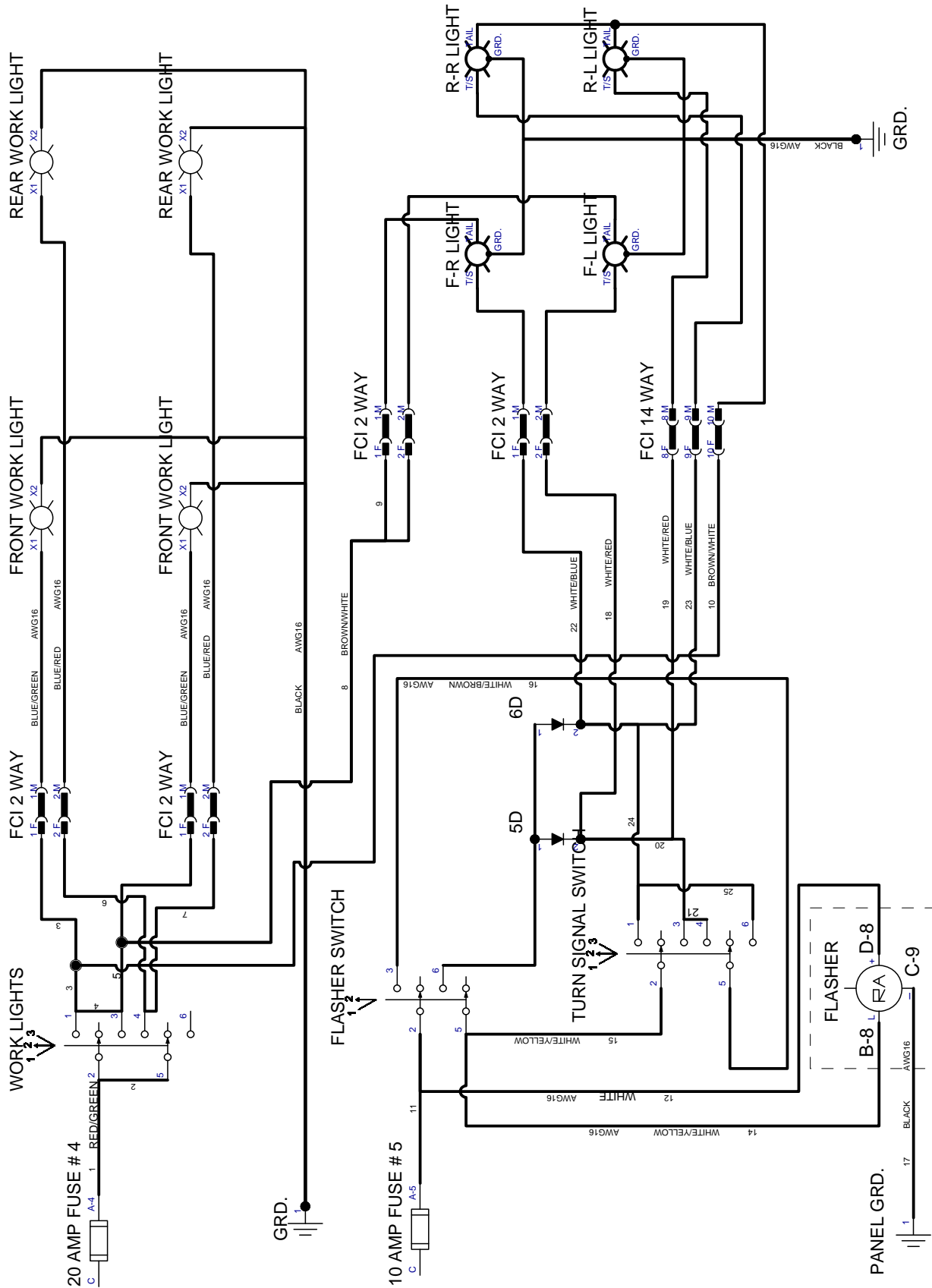

Trans Brake Electrical Circuit

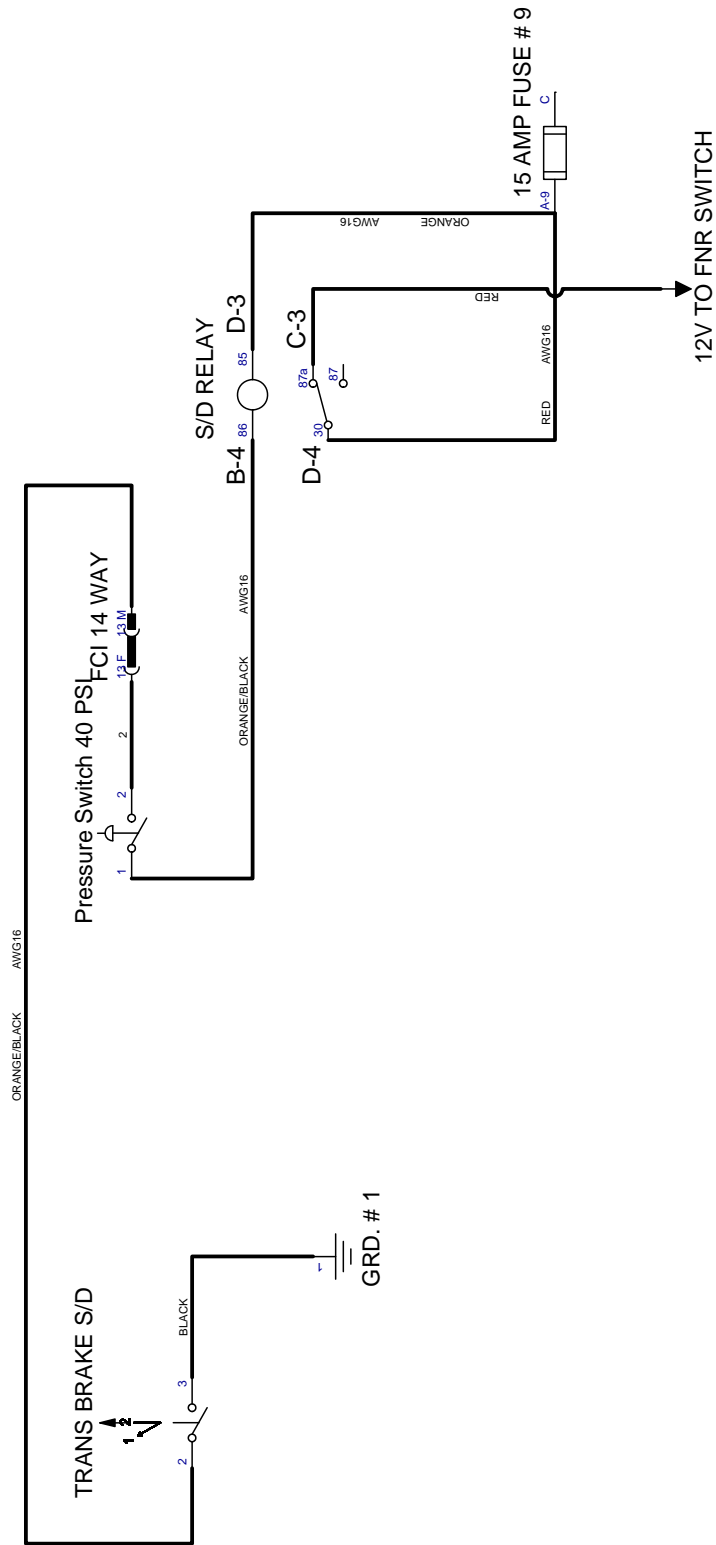

REFERENCE DOCUMENTS:

GVF 5000 Forklift Parts Manual

Part Number: GL11485

GVF 5000 Forklift Service Manual

Part Number: GL11490

Transmission SS 700 Service Manual

Part Number: 9803/9070

Front Axle PD 70 Service Manual

Part Number: 9803/9100

Rear Axle SD 55 Service Manual

Part Number: 9803/9283

JCB 444 Engine Service Manual

Part Number: 9806/3000

FILTER PART NUMBERS

Engine Oil Filter

Part Number: GL 11670

Tier III Fuel Prefilter and Water Trap

Part Number: GL 12535

Fuel Filter 5 Micron

Part Number: GL 11680

Transmission Oil Filter

Part Number: GL 11685

Hydraulic Oil Filter

Part Number: GL 11690

Tier III Engine Air Filters:

Primary Filter

Part Number: GL 12265

Safety Filter

Part Number: GL 12270

GVF WARRANTY

Gillison's Variety Fabrication, Inc. will replace or repair at GVF option, any GVF manufactured item that is, in the opinion of GVF, defective in material or workmanship for a period of 1 year or 1,000 hours, whichever comes first, from the date of purchase, and is returned to the GVF plant or service center at the expense of the customer. This warranty is made expressly in lieu of all other warranties expressed or implied. **The Warranty Registration card must be completed in full and returned to GVF within thirty (30) days of date of delivery to qualify for this warranty.**

The owner is specifically responsible for the operation and service of the machine. This warranty shall not apply to any product that has been subject to misuse, negligence or accident. In the event of a defect in material or workmanship, GVF sole responsibility is to the repair or replacement of the defective part and is not responsible for lost time or any other expenses incurred due to lost time.

All OEM items such as Tires, Batteries, Engines and Hydraulic components are warranted by the original equipment manufacturer. GVF controls the installation of these products but not the manufacture; therefore, GVF warranty applies to the proper installation but not the OEM component itself.

Retail Customer Responsibility: It is the Retail Customer and/or Operator's responsibility to read the Operator's Manual to operate, lubricate, maintain, and store the product in accordance with all instructions and safety procedures. Failure of the operator to read the Operator's Manual is misuse of this equipment. It is the Retail Customer and/or Operator's responsibility to inspect the product and to have any part(s) repaired or replaced when continued operation would cause damage or excessive wear to other parts or cause a safety hazard.

It is the Retail Customer's responsibility to deliver the product to the authorized GVF dealer, from whom he purchased it, for service or replacement of defective parts, which are covered by warranty. Repairs to be submitted for warranty consideration must be made within 45 days of failure. The Retail Customer is responsible for any cost incurred by the Dealer for traveling to or hauling of the product for the purpose of performing a warranty obligation or inspection.