

NEW



ROUGH TERRAIN FORK LIFT | 930/940/950

Gross power: 74hp | Lift capacity: 6,000 - 10,000 lbs | Lift height: 15 - 22 feet



<https://forklift-manuals.jimdofree.com>

PRODUCTIVITY AND PERFORMANCE.

WHEN YOU'RE ON-SITE, PRODUCTIVITY AND PERFORMANCE ARE NATURALLY YOUR PRIMARY CONCERNS. THE LATEST JCB ROUGH TERRAIN FORKLIFTS OFFER PLENTY OF FEATURES DESIGNED TO ENSURE BOTH.

Engine and hydraulics.

The 4.4-liter JCB EcoMAX T4 Final-compliant engine produces its peak power (74hp) and torque (295lb-ft) at engine speeds as low as 1200 rpm for great responsiveness.

A fixed geometry turbo further enhances performance at low engine speeds for improved power and tractive effort.



Our new larger high-flow hydraulic pump translates power into efficient lifting for increased productivity; and faster cycle times.



Moving with the times.

1 Model options comprise the 930 (6,000lbs lift capacity), 940 (8,000lbs lift capacity), 950 (10,000lbs lift capacity).

2 You can fine-tune your RTFL to any application and terrain; there's a choice of large diameter traction or industrial tires; 48", 60" or 72" long pallet forks; as well as the option of 2WD or 4WD on every model.

3 So that you can choose from a huge range of options to boost productivity, we offer an optional single or double acting mast auxiliary.

4 Choose from two different carriage options: 60" or 72" Industrial Class IIIB ITA, or 66" or 84" floating shaft carriage.

A smooth operation.

5 The left column-mounted powershuttle gives the operator fast and easy directional control.

6 As part of JCB's Vertical Integration Strategy, we build the engine, transmission, hydraulic rams and cab of every RTFL so that they'll work in perfect harmony. The end result is minimum compromise, optimum performance.

7 All-wheel servo braking provides smooth and responsive stopping power and is fitted as standard on the 940 and 950 models, or as an option on the 930 model.



COMFORT AND EASE OF USE.

TO ACHIEVE MAXIMUM PRODUCTIVITY, A ROUGH TERRAIN FORKLIFT OPERATOR NEEDS TO BE COMFORTABLE AND IN CONTROL. AS SUCH, WE'VE CREATED A WORKPLACE THAT GETS THE BEST FROM YOUR OPERATORS AND YOUR MACHINERY.

A great place to work

For all-day productive comfort, we offer both suspension and air suspension seating options that can be adjusted to different operator requirements or tasks.

1 In-cab noise levels are reduced, partly due to our positioning of the exhaust system towards the rear of the machine.

2 Operators can see both sides of the mast and carriage easily thanks to the slimline outer mast section.

Excellent upward visibility is provided by a large roof screen; in fact, visibility all-around is excellent, courtesy of direct glazing, fold-back rear doors, a low hood, high cab mounting position, and large front and rear windscreens.

3 Optional front and rear work lights provide ultimate all-around visibility.



The large, spacious cab of our new RTFLs boasts left and right grab handles with wide-opening fold back doors for easy access; standard-fit tinted glass which reflects 30% of the sun's energy; and a new 3-speed heater fan for improved demisting/de-icing of the windscreen in cold weather.

Quality design.

- 4** New laser-etched switches are backlit to aid recognition and night visibility, while our simple lever controls ensure total command of mast and auxiliary functions.
- 5** You can lift and place loads even more easily with our optional sideshift carriage.
- 6** A zero tail swing design means that when the rear tire of a JCB RTFL has cleared an obstacle on full turn, you can be safe in the knowledge that the rear counterweight will clear it too. This means our machines are ideal for working in confined areas.
- 7** JCB RTFLs are sold all over the world, so we offer a choice of cab (with or without air conditioning) or canopy to suit different climates.
- 8** These machines come equipped with a simple, robust 4-speed synchromesh transmission that helps to achieve a top speed of 18mph.



QUALITY/RELIABILITY/DURABILITY.

WE BUILD OUR ROUGH TERRAIN FORKLIFTS TO GO THE DISTANCE NO MATTER HOW TOUGH THE TASK. THAT'S WHY WE USE STATE-OF-THE-ART MANUFACTURING TECHNIQUES, RUGGED MATERIALS AND INNOVATIVE DESIGN TO CREATE THE STRONGEST MACHINES POSSIBLE.

A comfortable operator.

- 1 Our hydraulic cylinders have friction-welded eye-ends for extra strength, plus all pivots use hardened pins.
- 2 The one-piece fully welded chassis maximizes strength and minimizes weight.
- 3 Axles on the RTFL are the same heavy-duty units we fit to our backhoe loaders and Loadalls.
- 4 A mast on one of our RTFLs is made from heavy-duty channel and I-section steel, while the heavy-duty chains and guide roller bearings are sealed for life.

By electrochemically dipping the cab before applying paint, we give these machines highly effective long-term corrosion protection.



Hydraulic rams, cabs, axles, transmissions and engines are all JCB-built, so you can expect optimum reliability and performance.

The JCB approach.

- 5 Like every JCB machine, our RTFLs are put through a stringent testing program which includes prolonged high stress loading of the chassis, mast and other key components, as well as repeated transmission use over thousands of cycles.
- 6 We use state-of-the-art manufacturing processes like robot machining, precision paint technology and innovative assembly techniques to achieve the very highest levels of quality.
- 7 JCB engines are tried and trusted. We've built 200,000 DIESELMAX engines since 2004, and we've tested our new EcoMAX design for 110,000 hours in 70 different machines across the toughest applications and environments.



A SOUND INVESTMENT.

A JCB ROUGH TERRAIN FORKLIFT ISN'T JUST EFFICIENT TO USE – IT'S HUGEY EFFICIENT TO OWN AND OPERATE TOO. WE'VE DESIGNED THESE MACHINES TO GIVE YOU THE MAXIMUM POSSIBLE RETURN ON YOUR INVESTMENT, WITH GREAT FUEL EFFICIENCY AND LOW RUNNING COSTS ALL PART OF THE PACKAGE.

EcoMAX efficiency.

1 Our new 74hp high-torque EcoMAX engine maximizes both productivity and efficiency.

These T4 Final-compliant RTFLs are products of our Efficient Design program and, as such, use up to 10% less fuel than our outgoing Tier 3 models.

2 Because its peak power and torque are produced at low engine speeds, EcoMAX provides fuel-efficient matching of transmission and hydraulics.

Returning your investment.

3 The new larger hydraulic pump efficiently transforms power into lifting force for fast cycle times and improved fuel economy.

4 Every 4WD RTFL can be changed to 2WD at the flick of a switch, reducing fuel consumption and tire wear whenever 4WD isn't required – during roading, for example.

JCB's EcoMAX engine design doesn't need exhaust after-treatment, so costly heat-resistant lube oils or AdBlue are unnecessary; in turn, you save on servicing costs.



SERVICEABILITY.

NOBODY LIKES DOWNTIME BUT MACHINE SERVICING IS, OF COURSE, UNAVOIDABLE. FORTUNATELY, OUR ROUGH TERRAIN FORKLIFTS ARE SO RUGGED THAT THEY REQUIRE LESS SERVICING THAN MOST, ENSURING MAXIMUM PRODUCTIVE UPTIME.

Simple servicing.

1 On a JCB RTFL, all daily checks can be carried out easily at ground level; grease points are all accessible from ground level too.

Gas-assisted cylinders make opening the hood easy, and the large wide service bay provides good access to two sides of the engine.

2 The air filter on these machines is easily accessible, and a single-element construction simplifies cleaning.

3 All of the filters (engine oil, fuel, transmission, hydraulic oil and air) are located close to each other for fast, simple servicing.

4 It's easy to get to the diesel tank on one of our new RTFLs, and it can be filled from ground level too. There's also an integral pre-filter in the filler neck for protection against dirty fuel.

5 Our hydraulic tank is easily accessible and can be filled from ground level.

Minimized downtime.

Although most Tier 4 FINAL engines require exhaust after-treatment like a Diesel Particulate Filter (DPF) or SCR, EcoMAX doesn't; this means you don't need to worry about costly heat-resistant lube oils or AdBlue fluid level maintenance.

To keep our machines productive, we minimize downtime as much as possible; service intervals are therefore long.

JCB LiveLink telematics technology offers a whole range of benefits. Real-time data keeps you in complete control of your machine, allowing you to monitor and manage it remotely. You can also monitor any issues and get them resolved swiftly by your JCB dealer, thus boosting productivity throughout the working day.

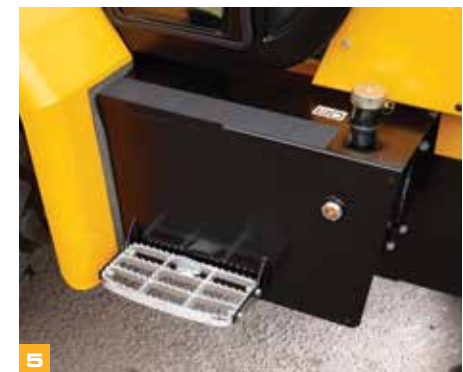

SAFETY AND SECURITY.

SAFETY IN THE WORKPLACE IS MORE IMPORTANT THAN EVER, AND OUR NEW ROUGH TERRAIN FORKLIFTS ARE BUILT WITH THIS IN MIND. OPERATORS, MACHINERY AND BYSTANDERS ALIKE ARE WELL-PROTECTED FROM HAZARDS.

A safer workplace

- 1 Ergonomically positioned grab handles and two cab steps provide quick, easy and safe operator access with three points of contact at all times.
- 2 Hydraulic velocity fuse (HVF) on the rams guard against collapse in the event of a hose failure.
- 3 We fit our RTFLs with a reversing alarm as standard.
- 4 Our seat safety switch disables forward/reverse controls whenever the operator isn't seated.
- 5 All cabs on our RTFLs are FOPS (Falling Objects Protection System) certified, ensuring excellent operator protection at all times.
- 6 For even greater operator protection against falling debris, opt for our front screen guard.

Security features

- 7 A factory-fit JCB immobilizer can be either key or keypad-activated; it also automatically arms itself after a set period following engine shutdown. This technology helps to safeguard your machine.



JCB's LIVELINK telematics GPS tracking system provides real-time machine location data with Geofencing alerts; this allows you to track machine coverage and protect your investment.

LIVELINK, WORK SMARTER.

LIVELINK IS AN INNOVATIVE SOFTWARE SYSTEM THAT LETS YOU MANAGE JCB MACHINES REMOTELY – ONLINE, BY EMAIL OR BY MOBILE PHONE. ACCESS EVERYTHING FROM MACHINE ALERTS TO FUEL REPORTS AND HISTORY INFORMATION, WITH ALL DATA STORED AT A SECURE CENTER.

Productivity and cost benefits

By providing information like idle time monitoring and machine fuel consumption, JCB Livelink helps reduce your fuel usage, saving money and improving productivity. Machine location information can help improve efficiency and perhaps even reduce insurance costs.

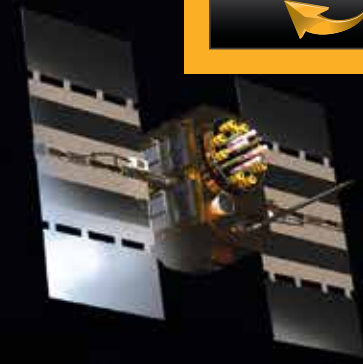

Maintenance benefits

Manage machine maintenance easily – accurate hours monitoring and service alerts improve maintenance planning, while real-time location data helps you manage your fleet. Critical machine alerts and maintenance history records are also available.



Security benefits

Livelink's real-time geofencing alerts tell you when machines move out of predetermined zones, and real-time curfew alerts inform you of unauthorized usage. Further benefits include real-time location information.



VALUE ADDED.

JCB'S WORLDWIDE CUSTOMER SUPPORT IS FIRST CLASS. WHATEVER YOU NEED AND WHEREVER YOU ARE, WE'LL BE AVAILABLE QUICKLY AND EFFICIENTLY TO HELP MAKE SURE YOUR MACHINERY IS PERFORMING TO ITS FULL POTENTIAL.



1 Our Technical Support Service provides instant access to factory expertise, day or night, while our Finance and Insurance teams are always on hand to provide fast, flexible, competitive quotes.

2 The global network of JCB Parts Centers is another model of efficiency; with 15 regional bases, we can deliver around 95% of all parts anywhere in the world within 24 hours. Our genuine JCB parts are designed to work in perfect harmony with your machine for optimum performance and productivity.



3 JCB Assetcare offers comprehensive extended warranties and service agreements, as well as service-only or repair and maintenance contracts. Irrespective of what you opt for, our maintenance teams around the world charge competitive labor rates, and offer non-obligation quotations as well as fast, efficient insurance repair work.

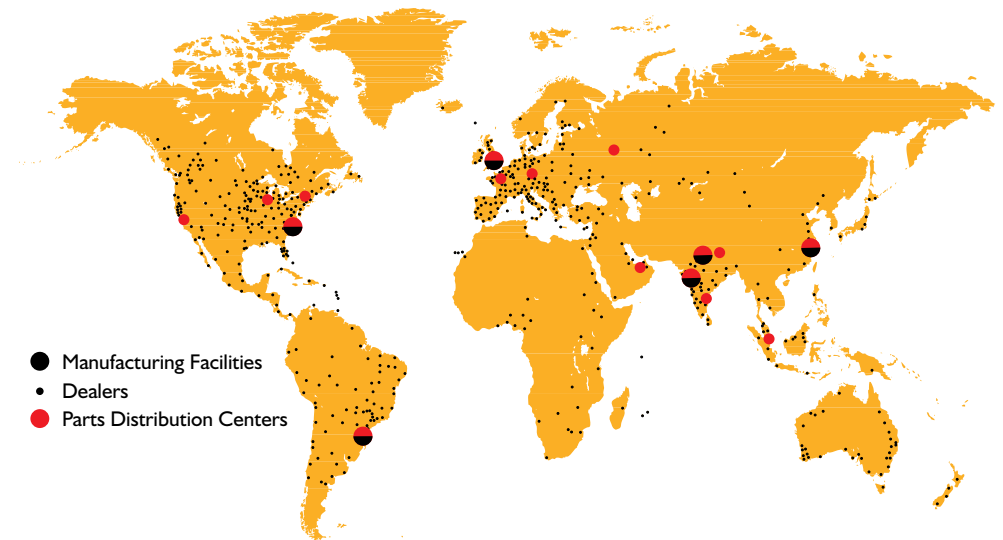

Note: JCB LIVELINK and JCB ASSETCARE may not be available in your region, so please check with your local dealer.

STATIC DIMENSIONS

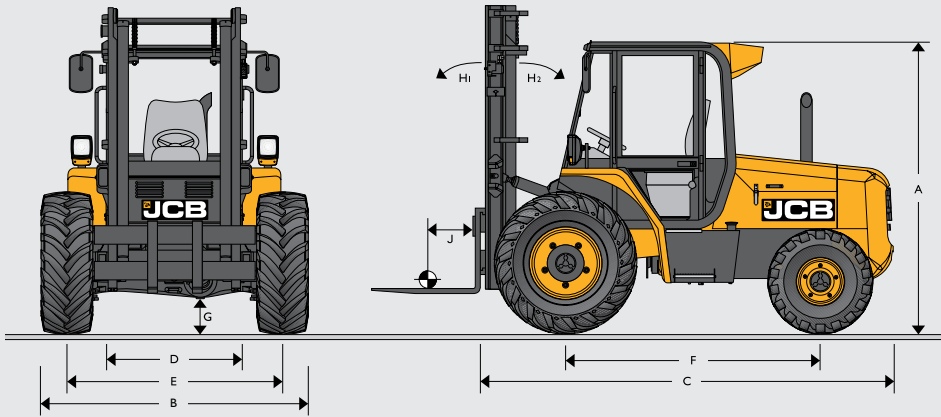

| Machine model | | 930 | 940 | 950 | |
|---------------|----------------------------------|--------|-------|-------|-------|
| A | Overall cab height | ft in | 8'4" | 8'4" | 8'4" |
| B | Overall width (over tires) | ft in | 7'2" | 7'2" | 7'2" |
| C | Overall length to front carriage | ft in | 11'7" | 11'9" | 11'9" |
| D | Inside width of cab | ft in | 3'6" | 3'6" | 3'6" |
| E | Front track | ft in | 5'9" | 5'9" | 5'9" |
| F | Wheel base | ft in | 6'9" | 7'2" | 7'2" |
| G | Ground clearance | ft in | 10" | 10" | 10" |
| H1 | Mast tilt forwards | degree | 18° | 18° | 18° |
| H2 | Mast tilt backwards | degree | 10° | 10° | 10° |
| J | Load center | ft in | 21" | 21" | 21" |

The above data is based on the following specification: Standard fork size 42 x 3 x 1 inch.

WEIGHT

| Machine model | | 930 | 940 | 950 |
|---|----|--------|--------|--------|
| Machine weight with following mast | | | | |
| 15' 0" Freelift | lb | 13,985 | 15,190 | - |
| 22' 0" Clearview | lb | 14,495 | 15,750 | 17,295 |
| 22' 0" Freelift | lb | 14,600 | 18,810 | - |

The above data is based on the following specification: Standard fork size 42 x 3 x 1 inch.

TURN RADIUS AND GROUND LINE ANGLES

| Machine model | | 930 | 940 | 950 |
|-------------------------|-------|----------|----------|----------|
| Outside turn radius 2WD | ft in | 14' 4.4" | 14' 7.2" | 14' 7.2" |
| Outside turn radius 4WD | ft in | 14' 3.3" | 16' 1.7" | 16' 1.7" |
| Departure angle | | 53° | 53° | 53° |
| Obstruction angle | | 51° | 51° | 51° |

The above data is based on the following specification: Standard fork size 42 x 3 x 1 inch.

ENGINE

| Machine model | 930/940/950 | |
|------------------------------------|--------------------|------|
| Model | JCB ECOMAX TCAE-55 | |
| Displacement | liters | 4.4 |
| Fuel | Diesel | |
| Cooling | Liquid | |
| Bore | in | 4.05 |
| Stroke | in | 5.19 |
| Gross power – ISO 14396 @2000 rpm | hp) | 74 |
| Gross torque – ISO 14396 @1300 rpm | lb-ft | 295 |
| Emission certification | TIER IV FINAL | |
| Engine oil service intervals | 500 hours | |

TRANSMISSION

| Machine model | 930/940/950 | |
|------------------------|---------------|--|
| Manufacturer | JCB | |
| Type | Synchromesh | |
| Torque converter | 11 inches | |
| Torque converter ratio | 2.20:1 | |
| Gears forward/reverse | 4/4 | |
| Gear selection | Manual | |
| Shuttle control - F/R | Power shuttle | |
| Travel speeds | mph | |
| Gear 1 | 3.2 | |
| Gear 2 | 5.3 | |
| Gear 3 | 10.1 | |
| Gear 4 | 18.4 | |

For unbeatable drive power in all conditions, the JCB Synchro Shuttle combines a 4-speed, fully synchromesh gearbox with integral torque converter and electrically operated reversing shuttle for smooth gear changes on the move and fast cycle times. Column mounted electric switch effortlessly controls machine direction changes allowing operator to keep hands on steering wheel. Automotive style pedal layout and conventional H-pattern gear lever add to ease of operation. Travel speed 18mph. Front drive axle: JCB epicycle hub reduction drive axle with Max-Trac torque proportioning differentials. Rear steer axles: JCB manufacture with hydrostatic power steering. Steer shock valve as standard. 4WD versions with epicyclic hub reduction and Max-Trac torque proportioning differentials.

TIRES

| Machine model | 930/940/950 | |
|----------------|---------------------|--|
| Standard Tires | 15.5-25 | |
| Front 2WD | 15.5-25 (12 ply) | |
| Rear 2WD | 12.5/80-18 (10 ply) | |
| Front 4WD | 15.5-25 (12 ply) | |
| Rear 4WD | 14-17.5 (10 ply) | |

ELECTRICAL SYSTEM

| Machine model | 930/940/950 | |
|-------------------|-------------|-----|
| System voltage | Volt | 12 |
| Alternator output | Amp hour | 95 |
| Battery capacity | Amp hour | 120 |

SERVICE CAPACITIES

| Machine model | 930/940/950 | |
|-------------------------|-------------|------|
| Fuel tank | gal | 19.3 |
| Hydraulic tank | gal | 13.1 |
| Engine oil sump | gal | 2.6 |
| Transmission oil system | gal | 4 |
| Engine coolant system | gal | 3.7 |

| | |
|---------------|--|
| BRAKES | Service brakes: Hydraulically activated, self-adjusting, oil-immersed in-board multi-disc type in front axle (930). Optional Hydraulic Servo assisted, self adjusting brakes on 930 standard on 940/950. Parking brake: Hand operated disc brake on output of gearbox. |
|---------------|--|

| | |
|-------------------|---|
| HYDRAULICS | Single gear pump with steer priority valve, suction strainer and filter. Operating system pressure: 3205 psi, flow 20gpm. Pipe burst protection on mast hydraulics. |
|-------------------|---|

| | |
|----------------------------|--|
| MASTS AND CARRIAGES | Clearview masts manufactured from channel and I-section steel. Heavy-duty mast chains. Guide roller bearings are sealed for life. Industrial class IIIB carriage, or floating shaft carriage available on various masts. Adjustable right hand tilt ram. |
|----------------------------|--|

| | |
|------------------------|---|
| OPERATOR MODULE | Safety quiet cab or canopy, FOPS standard (falling object protective structure) to ANSI B56.6 – 1978. Cab: Resiliently mounted, two door access, level floor with mat, safety glass all around with laminated roof window. Features include: Suspension cloth/vinyl seat, rear view mirror and 2 speed heater/demister. Front/Rear screen wiper and washer, horn. Handbook. Instruments for hour meter battery charge. Audible/Visual warning system for alternator charge, coolant temperature, engine oil pressure, blocked air filter, transmission oil pressure and temperature. Warning lights for: park brake on. Hydraulic control levers, gear lever, park brake, forward/reverse lever, 4WD disconnect, throttle, brake, and transmission disconnect button. Canopy: As above but with no glazing (screen wiper and heater/screen demister not applicable), and rear fenders are optional. |
|------------------------|---|

| | |
|--------------------------------|--|
| OPTIONS AND ATTACHMENTS | Wheel and tire sets. Air suspension seat. Roof screen washer/wiper. Flashing roof beacon. Fire extinguisher. Cab exterior mirrors. Front screen guard. Optional rear fenders. Reversing lights. Engine fan guard kit. Front and rear cab lights. Immobilizer. Roadlight. |
|--------------------------------|--|

PERFORMANCE DIMENSIONS - 930

| Description of mast | Overall lowered height (in) | Overall height raised (in) | Freelift (in) | Max height of mast lift (in) | Capacity at full height (lbs) | Mast raise/lower speed (ft/min) |
|-----------------------------|-----------------------------|----------------------------|---------------|------------------------------|-------------------------------|---------------------------------|
| 15' FL - 66" Shaft Carriage | 98.5 | 215.3 | 62.9 | 180.5 | 6000 | 1.0 (0.31) / 1.49 (0.45) |
| 15' FL - 84" Shaft Carriage | 98.5 | 215.3 | 62.9 | 180.5 | 6000 | 1.0 (0.31) / 1.49 (0.45) |
| 15' FL - 60" ITA Carriage | 98.5 | 215.3 | 64.5 | 182 | 6000 | 1.0 (0.31) / 1.49 (0.45) |
| 15' FL - 72" ITA Carriage | 98.5 | 215.3 | 64.5 | 182 | 6000 | 1.0 (0.31) / 1.49 (0.45) |
| 22' CV - 66" Shaft Carriage | 126.5 | 301.8 | - | 264.5 | 2500 | 1.64 (0.5) / 1.75 (0.53) |
| 22' CV - 84" Shaft Carriage | 126.5 | 301.8 | - | 264.5 | 2500 | 1.64 (0.5) / 1.75 (0.53) |
| 22' CV - 60" ITA Carriage | 126.5 | 301.8 | - | 266 | 2500 | 1.64 (0.5) / 1.75 (0.53) |
| 22' CV - 72" ITA Carriage | 126.5 | 301.8 | - | 266 | 2500 | 1.64 (0.5) / 1.75 (0.53) |
| 22' FL - 66" Shaft Carriage | 126.5 | 299.3 | 91 | 264.5 | 2500 | 1.0 (0.31) / 1.49 (0.45) |
| 22' FL - 84" Shaft Carriage | 126.5 | 299.3 | 91 | 264.5 | 2500 | 1.0 (0.31) / 1.49 (0.45) |
| 22' FL - 60" ITA Carriage | 126.5 | 299.3 | 92.5 | 266 | 2500 | 1.0 (0.31) / 1.49 (0.45) |
| 22' FL - 72" ITA Carriage | 126.5 | 299.3 | 92.5 | 266 | 2500 | 1.0 (0.31) / 1.49 (0.45) |

PERFORMANCE DIMENSIONS - 940

| Description of mast | Overall lowered height (in) | Overall height raised (in) | Freelift (in) | Max height of mast lift (in) | Capacity at full height (lbs) | Mast raise/lower speed (ft/min) |
|-----------------------------|-----------------------------|----------------------------|---------------|------------------------------|-------------------------------|---------------------------------|
| 15' FL - 66" Shaft Carriage | 98.5 | 215.3 | 62.9 | 180.5 | 8000 | 1.48 (0.45) / 1.63 (0.49) |
| 15' FL - 84" Shaft Carriage | 98.5 | 215.3 | 62.9 | 180.5 | 8000 | 1.48 (0.45) / 1.63 (0.49) |
| 15' FL - 60" ITA Carriage | 98.5 | 215.3 | 64.5 | 182 | 8000 | 1.48 (0.45) / 1.63 (0.49) |
| 15' FL - 72" ITA Carriage | 98.5 | 215.3 | 64.5 | 182 | 8000 | 1.48 (0.45) / 1.63 (0.49) |
| 22' CV - 66" Shaft Carriage | 126.5 | 301.8 | - | 264.5 | 3500 | 1.64 (0.5) / 1.75 (0.53) |
| 22' CV - 84" Shaft Carriage | 126.5 | 301.8 | - | 264.5 | 3500 | 1.64 (0.5) / 1.75 (0.53) |
| 22' CV - 60" ITA Carriage | 126.5 | 301.8 | - | 266 | 3500 | 1.64 (0.5) / 1.75 (0.53) |
| 22' CV - 72" ITA Carriage | 126.5 | 301.8 | - | 266 | 3500 | 1.64 (0.5) / 1.75 (0.53) |
| 22' FL - 66" Shaft Carriage | 126.5 | 299.3 | 91 | 264.5 | 3500 | 1.48 (0.45) / 1.63 (0.49) |
| 22' FL - 84" Shaft Carriage | 126.5 | 299.3 | 91 | 264.5 | 3500 | 1.48 (0.45) / 1.63 (0.49) |
| 22' FL - 60" ITA Carriage | 126.5 | 299.3 | 92.5 | 266 | 3500 | 1.48 (0.45) / 1.63 (0.49) |
| 22' FL - 72" ITA Carriage | 126.5 | 299.3 | 92.5 | 266 | 3500 | 1.48 (0.45) / 1.63 (0.49) |

PERFORMANCE DIMENSIONS - 950

| Description of mast | Overall lowered height (in) | Overall height raised (in) | Freelift (in) | Max height of mast lift (in) | Capacity at full height (lbs) | Mast raise/lower speed (ft/min) |
|--------------------------------------|-----------------------------|----------------------------|---------------|------------------------------|-------------------------------|---------------------------------|
| 15' FL - 66" Shaft Carriage | 215.3 | | 62.9 | 180.5 | 10000 | 1.64 (0.5) / 1.75 (0.53) |
| 15' FL - 84" Shaft Carriage | 215.3 | | 62.9 | 180.5 | 10000 | 1.64 (0.5) / 1.75 (0.53) |
| 15' FL - 60" ITA Carriage | 215.3 | | 64.5 | 182 | 10000 | 1.64 (0.5) / 1.75 (0.53) |
| 15' FL - 72" ITA Carriage | 215.3 | | 64.5 | 182 | 10000 | 1.64 (0.5) / 1.75 (0.53) |
| 22' CV - 66" Floating Shaft Carriage | 126.5 | 301.8 | - | 264.5 | 6500 | 1.64 (0.5) / 1.75 (0.53) |
| 22' CV - 84" Floating Shaft Carriage | 126.5 | 301.8 | - | 264.5 | 6500 | 1.64 (0.5) / 1.75 (0.53) |
| 22' CV - 60" Hook Carriage | 126.5 | 301.8 | - | 264.5 | 6500 | 1.64 (0.5) / 1.75 (0.53) |
| 22' CV - 72" Hook Carriage | 126.5 | 301.8 | - | 264.5 | 6500 | 1.64 (0.5) / 1.75 (0.53) |





ONE COMPANY, OVER 300 MACHINES.

Your nearest JCB dealer

ROUGH TERRAIN FORK LIFT 930/940/950

Gross power: 74hp Lift capacity: 6,000 - 10,000 lbs Lift height: 15 - 22 feet

JCB North American – Headquarters

Savannah, 2000 Bamford Blvd., Savannah, Georgia, 31322 Tel: (912) 447-2000

Download the very latest information on this product range at www.jcb.com

JCB inc. All rights reserved. No part of this publication may be reproduced, stored in a retrieval system, or transmitted in any form or by any other means, electronic, mechanical, photocopying or otherwise, without prior permission from JCB inc. All references in this publication to operating weights, sizes, capacities and other performance measurements are provided for guidance only and may vary dependent upon the exact specification of machine. They should not therefore be relied upon in relation to suitability for a particular application. Guidance and advice should always be sought from your JCB Dealer. JCB reserves the right to change specifications without notice. Illustrations and specifications shown may include optional equipment and accessories. The JCB logo is a registered trademark of J C Bamford Excavators Ltd.

[f /JCB](#)
 [t /JCBNA](#)
 [v /JCBNORTHAMERICA](#)

<https://forklift-manuals.jimdofree.com>

