

ROUGH TERRAIN - VERTICAL MAST SERIES • MODELS TS 6-44 & TS 8-44



www.Tovel.com



TOVEL SUPER LIFT
ROUGH TERRAIN - VERTICAL MAST SERIES

**6000 & 8000 lb CAPACITY
4 WHEEL DRIVE • 4 WHEEL STEER**



ROUGH TERRAIN - VERTICAL MAST SERIES • MODELS TS 6-44 & TS 8-44

GENERAL DATA:

- **CAPACITY** : 6,000 or 8,000 pounds at 24" load centre.
- **ENGINE** : Diesel 92 horsepower.
- **TRANSMISSION** : Powershift forward and reverse. with neutral safety switch and back-up beeper.
- **STEERING** : Power assist 2 wheel and crab.
- **AXLES** : Front & Rear. Planetary reduction c/w limited slip differential.
- **BRAKES** : Power - Equipped fully hydraulic power brakes. System includes an accumulator failsafe to apply stopping power in the event of engine shutdown.
- **TIRES** : Front & Rear 16.9 x 24
- **MAST** : Tovel design "Openview" constructed from H.D. "I" beam section, moving on roller mast guide bearings.
- **FRAME LEVELING** to 10 degrees. Left & Right.
- **SHIPPING WEIGHT** : 12,100 or 13,500 pounds.

DIMENSIONS	TS 6-44	TS 8-44
A WHEELBASE	92"	92"
B OVERALL LENGTH (LESSFORKS)	163"	163"
C TOP OF CANOPY	102"	102"
D OVERALL HEIGHT	VARIES BY MAST	
E OVERALL WIDTH	88"	96"
OUTSIDE TURNING RADIUS	126"	126"
MAXIMUM SPEED	20 mph	20 mph
GROUND CLEARANCE	18"	18"

STANDARD EQUIPMENT:

- Neutral gear select safety start ignition switch
- Full gauge cluster includes hour meter
- Dash mount horn switch
- Back-up beeper
- Vandalism lockout protection to main components and gauge cluster
- Electrical system 12 volt, two heavy duty batteries
- Dry type air cleaner element
- Operator compartment protected by canopy
- Mechanical lever for emergency hand brake
- Fenders on all four tires
- 50" carriage with 48" forks
- Adjustable seat complete with seat belt

OPTIONAL EQUIPMENT:

(for any items not listed consult your local dealer)

- Totally enclosed cab complete with safety glass and front windshield wiper
- Heating and air conditioning
- Various carriage and mast options (consult your local dealer)

THE INFORMATION CONTAINED HERE IN IS GENERAL IN NATURE AND IS NOT INTENDED FOR SPECIFIC APPLICATION PURPOSES. TOVEL RESERVES THE RIGHT TO MAKE CHANGES IN SPECIFICATIONS SHOWN HEREIN, AND IMPROVEMENTS, OR DISCONTINUE MANUFACTURE AT ANY TIME WITHOUT NOTICE OR OBLIGATION.

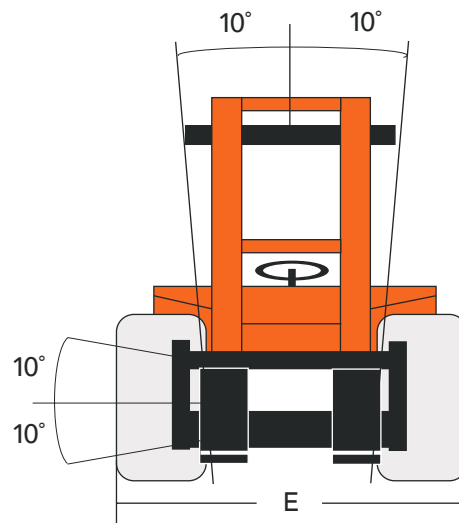
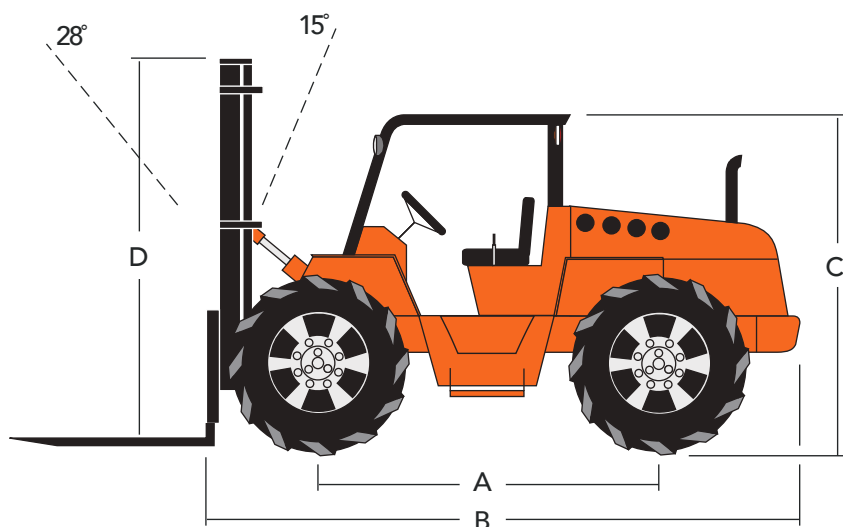

LIFTING PERFORMANCE AND STABILITY CONFORMS TO ANSI B56.6



www.Tovel.com

Manufacturing Facility:

77 Brawick Drive
Concord (Toronto), Ontario
Canada L4K 1K5

Toll Free: 800-273-9904 (CDA & USA)

Tel: 905.738.5511

Fax: 905.738.7934

Em: sales@tovel.com

For more information contact: