

Pos	Explanation	Signal description	Reference
22.	Solenoid valve VFS 1/3 (Y6075) controls servo pressure to Valve spool gear selection 1/3.	1200 kPa	Diagnostic menu, see section 8 <i>Control system</i> , group 8.4.7.7 <i>TRANSM</i> , menu 7
23.	The valve slide for gear 1/3 control opens when valve slide gear selection 1/3 is pressurised and leads a pressure signal to the drive control valve.	0-2000 kPa	-
24.	The valve slide for gear 2/4 control opens when valve slide gear selection 2/4 is pressurised and leads a pressure signal to the drive control valve.	0-2000 kPa	-
25.	Valve slide gear selection 2/4 pressurises drive clutch gear 2 or drive clutch gear 4.	0-2000 kPa	-
26.	Valve spool gear selection 1/3 pressurises Drive clutch gear 1 or Drive clutch gear 3.	0-2000 kPa	-
27.	Drive clutch forward locks the transmission in forward drive when the clutch is pressurised.	-	-
28.	Drive clutch gear 2 locks the transmission in gear position 2 when the clutch is pressurised.	-	-
29.	Drive clutch gear 4 locks the transmission in gear position 4 when the clutch is pressurised.	-	-
30.	Drive clutch reverse locks the transmission in reverse drive when the clutch is pressurised..	-	-
31.	Drive clutch gear 1 locks the transmission in gear position 1 when the clutch is pressurised.	-	-
32.	Drive clutch gear 3 locks the transmission in gear position 3 when the clutch is pressurised.	-	-
33.	The transmission oil pump pumps oil through the cooler and supplies the torque converter with oil pressure to run the machine.	85.1 l/min at 1973 rpm	-
34.	The oil filter cleans the oil.	-	-
35.	The bypass valve in the filter bracket leads the oil past the filter if the resistance through the filter becomes too high.	-	-
36.	The oil is distributed to different lubrication points in the transmission.	-	-
37.	The transmission oil cooler cools the oil.	-	-
38.	The torque converter transmits the engine's power to the transmission.	-	-
39.	The safety valve leads the oil back to the sump if the pressure in the torque converter becomes too high.	Opening pressure: 900 kPa	-

Transmission shifting, function description (transmission alternative Dana full flow)

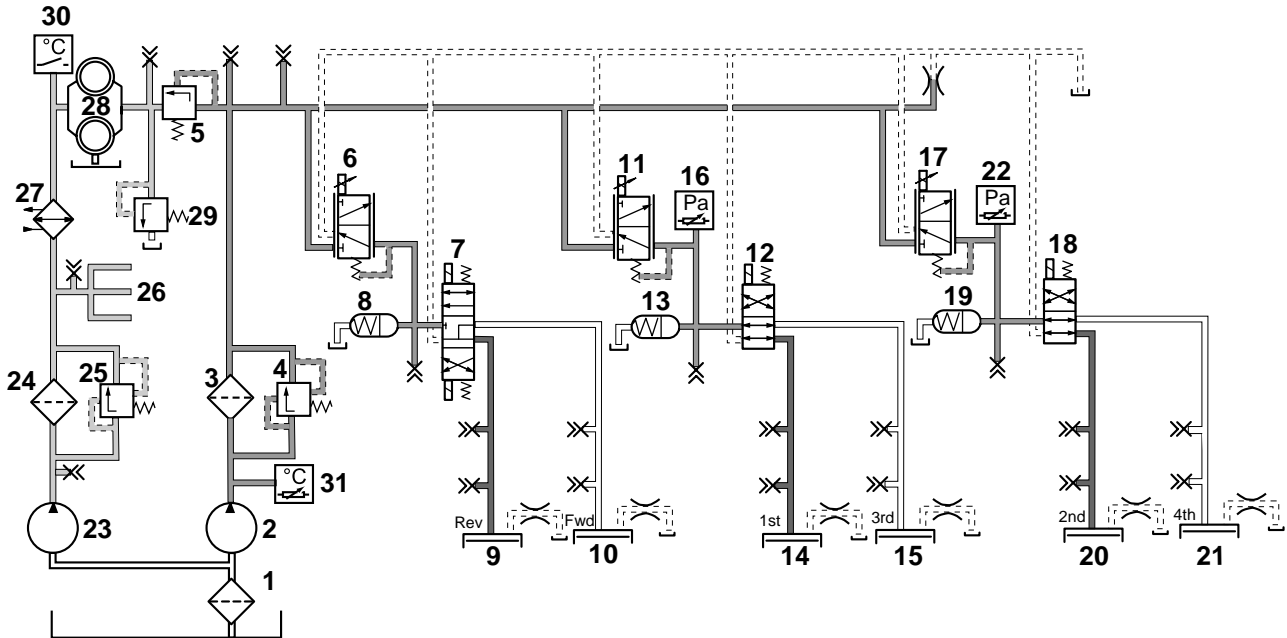

Pos	Explanation	Signal description	Reference
1	Bottom strainer oil sump, separates particles from the oil before the pumps.	-	-
2	The transmission's oil pump 1 feeds the transmission with control pressure for control of the transmission.	30.4 l/min at 685 rpm	-
3	The oil filter cleans the oil.	-	-
4	The bypass valve in the filter bracket leads the oil past the filter if the resistance through the filter becomes too high.	Opening pressure: 410-450 kPa	-
5	The pressure governor releases pressure to the torque converter if the pressure becomes too high.	Opening pressure: 2200 kPa	-
6	Servo valve front/rear (Y6300) controls pressure to Valve travel direction, proportional to the desired traction.	-	Diagnostic menu, see section 8 <i>Control system</i> , group 8.4.7.7 <i>TRANSM</i> , menu 7
7	Solenoid valve drive forward (Y6066F) or Solenoid valve drive reverse (Y6066R) controls Valve travel direction for drive forward or reverse. Depending on the solenoid valve activated, Valve travel direction controls pressure to drive clutch forward or drive clutch reverse.	-	Diagnostic menu, see section 8 <i>Control system</i> , group 8.4.7.8 <i>TRANSM</i> , menu 8 and 8.4.7.9 <i>TRANSM</i> , menu 9

Pos	Explanation	Signal description	Reference
8	The accumulator evens out the pressure.	-	-
9	Drive clutch reverse locks the transmission in reverse drive when the clutch is pressurised..	Drive reverse: 2200-2600 kPa	-
10	Drive clutch forward locks the transmission in forward drive when the clutch is pressurised.	Drive forward: 2200-2600 kPa	-
11	Servo Valve 1/3 (Y6067) controls pressure to Solenoid valve gear selection gear 1/3 (Y6075) proportional to the desired engagement force.	-	Diagnostic menu, see section 8 <i>Control system</i> , group 8.4.7.8 <i>TRANSM</i> , menu 8 and 8.4.7.9 <i>TRANSM</i> , menu 9
12	Solenoid valve gear selection gear 1/3 (Y6075) pressurises Drive clutch gear 1 or Drive clutch gear 3.	-	Diagnostic menu, see section 8 <i>Control system</i> , group 8.4.7.7 <i>TRANSM</i> , menu 7
13	The accumulator evens out the pressure.	-	-
14	Drive clutch gear 1 locks the transmission in gear position 1 when the clutch is pressurised.	Gear selected: 2200-2600 kPa	-
15	Drive clutch gear 3 locks the transmission in gear position 3 when the clutch is pressurised.	Gear selected: 2200-2600 kPa	-
16	Pressure sensor gear 1/3 (B6067) sends the transmission control unit (D793) a voltage signal proportional to engagement pressure.	-	Diagnostic menu, see section 8 <i>Control system</i> , group 8.4.7.10 <i>TRANSM</i> , menu 10
17	Servo Valve 2/4 (Y6069) controls pressure to Solenoid valve gear selection gear 1/3 (Y6075) proportional to the desired engagement force.	-	Diagnostic menu, see section 8 <i>Control system</i> , group 8.4.7.8 <i>TRANSM</i> , menu 8 and 8.4.7.9 <i>TRANSM</i> , menu 9
18	Solenoid valve gear selection gear 2/4 (Y6074) pressurises Drive clutch gear 1 or Drive clutch gear 3.	-	Diagnostic menu, see section 8 <i>Control system</i> , group 8.4.7.7 <i>TRANSM</i> , menu 7
19	The accumulator evens out the pressure.	-	-
20	Drive clutch gear 2 locks the transmission in gear position 2 when the clutch is pressurised.	Gear selected: 2200-2600 kPa	-
21	Drive clutch gear 4 locks the transmission in gear position 4 when the clutch is pressurised.	Gear selected: 2200-2600 kPa	-
22	Pressure sensor gear 2/4 (B6069) sends the transmission control unit (D793) a voltage signal proportional to engagement pressure.	-	Diagnostic menu, see section 8 <i>Control system</i> , group 8.4.7.10 <i>TRANSM</i> , menu 10
23	The transmission oil pump pumps oil through the cooler and supplies the torque converter with oil pressure to run the machine.	15.8 l/min at 685 rpm	-
24	The oil filter cleans the oil.	-	-
25	The bypass valve in the filter bracket leads the oil past the filter if the resistance through the filter becomes too high.	-	-

Pos	Explanation	Signal description	Reference
26	The oil is distributed to different lubrication points in the transmission.	-	-
27	The transmission oil cooler cools the oil.	-	-
28	The torque converter transmits the engine's power to the transmission.	-	-
29	The safety valve leads the oil back to the sump if the pressure in the torque converter becomes too high.	Opening pressure: 900 kPa	-
30	The torque converter temperature switch (S2210) sends the transmission control unit (D793) a voltage signal if oil temperature in the torque converter becomes too high.	-	Diagnostic menu, see section 8 <i>Control system</i> , group 8.4.7.10 <i>TRANSM</i> , menu 10
31	The oil temperature sensor (B7660) sends the transmission control unit (D793) a voltage signal proportional to oil temperature.	-	Diagnostic menu, see section 8 <i>Control system</i> , group 8.4.7.10 <i>TRANSM</i> , menu 10

Transmission, component location (transmission alternative Dana)

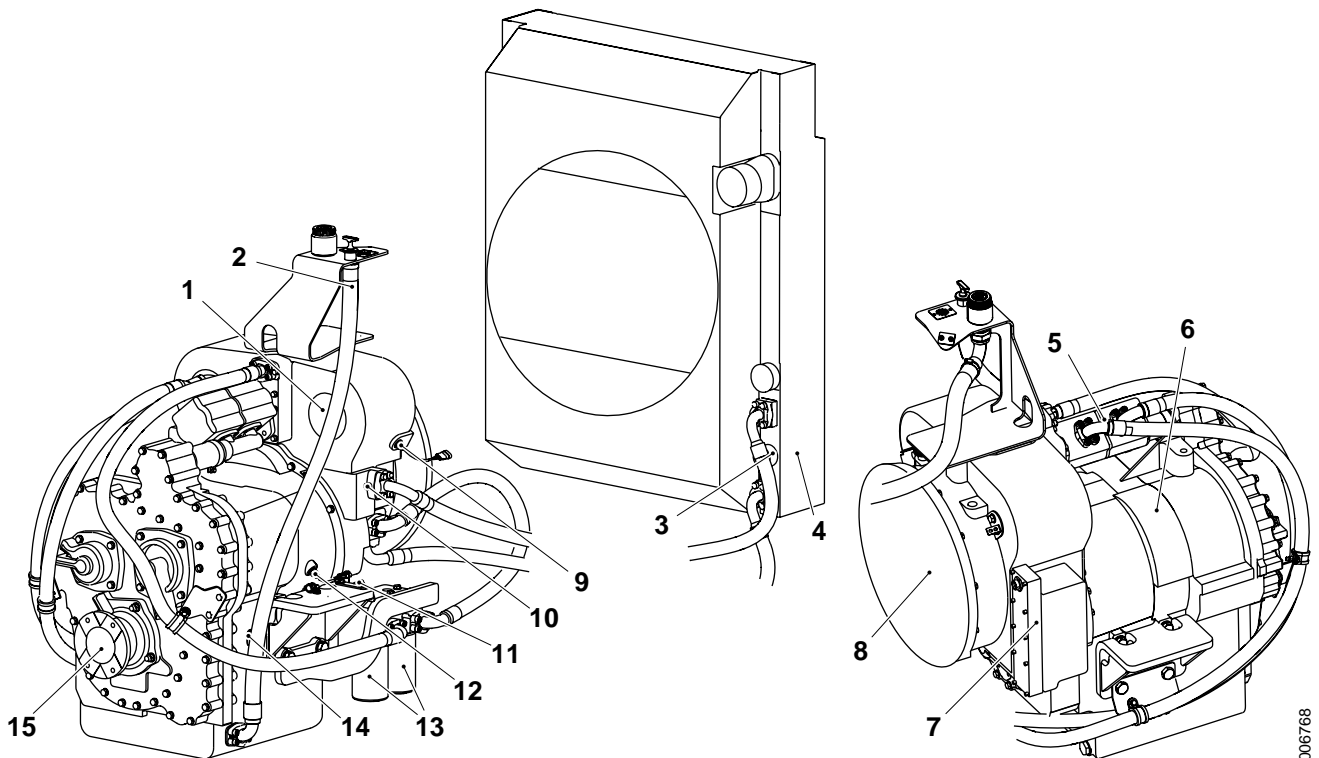

- | | |
|---|--|
| 1. Power take-off | 9. Engine rpm and oil temperature sensor (B758/766)
(from radiator to sump) |
| 2. Transmission oil dipstick and filler orifice | 10. Temperature switch, torque converter (S221) |
| 3. Thermostat | 11. Turbine speed sensor (B751) |
| 4. Transmission oil cooler | 12. Sensor, drum rpm (B752) |
| 5. Oil pump transmission | 13. Oil filter transmission |
| 6. Gearbox | 14. Sensor rpm output shaft (B758) |
| 7. Valve block transmission control | 15. Output shaft |
| 8. Torque converter | |

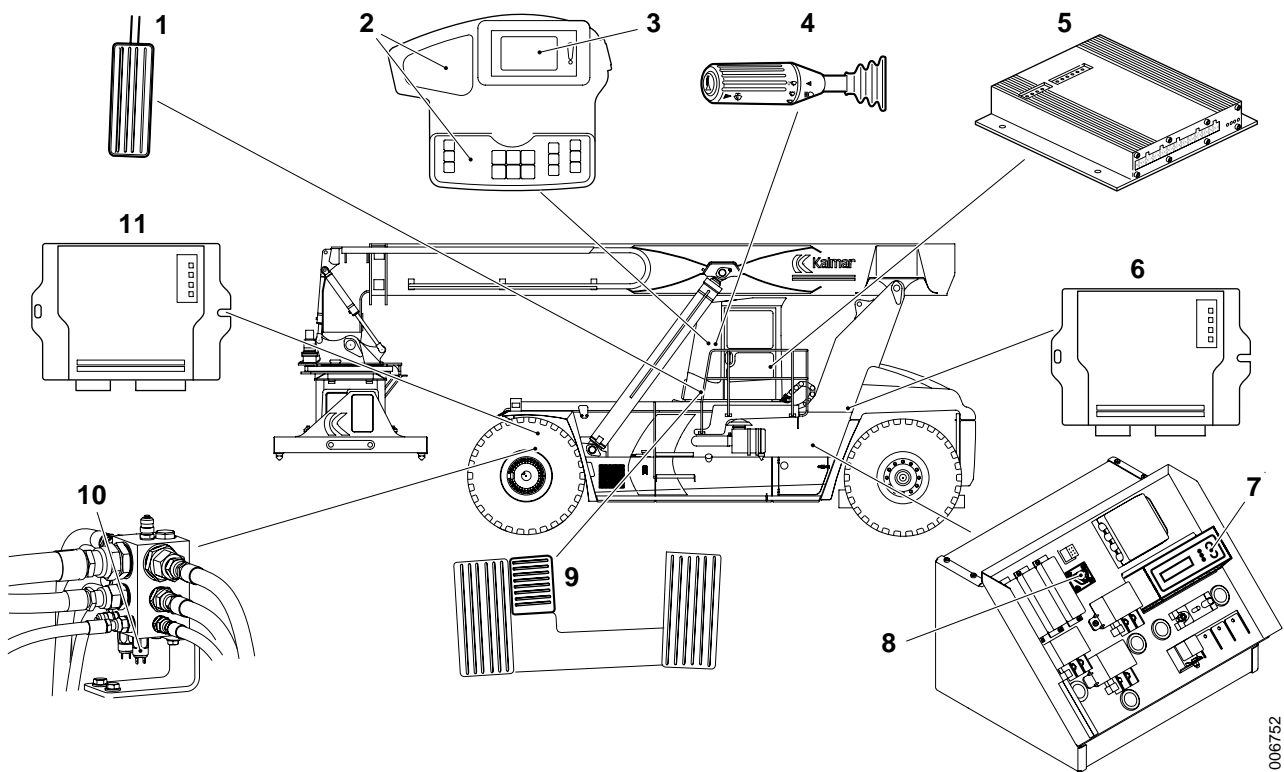

- | | | | |
|----|----------------------------------|-----|-----------------------------------|
| 1. | Accelerator pedal (B690) | 7. | Transmission control unit (D793) |
| 2. | Control unit KIT (D790-2) | 8. | Diagnostic socket, transmission |
| 3. | Control unit KID (D795) | 9. | Declutch pedal (S220-1) |
| 4. | Multi-function lever (S162) | 10. | NO switch, declutch (S220-2) |
| 5. | Control unit cab (D790-1) | 11. | Control unit frame front (D797-F) |
| 6. | Control unit frame rear (D797-R) | | |

006752

Transmission, component location (transmission alternative Dana full flow)

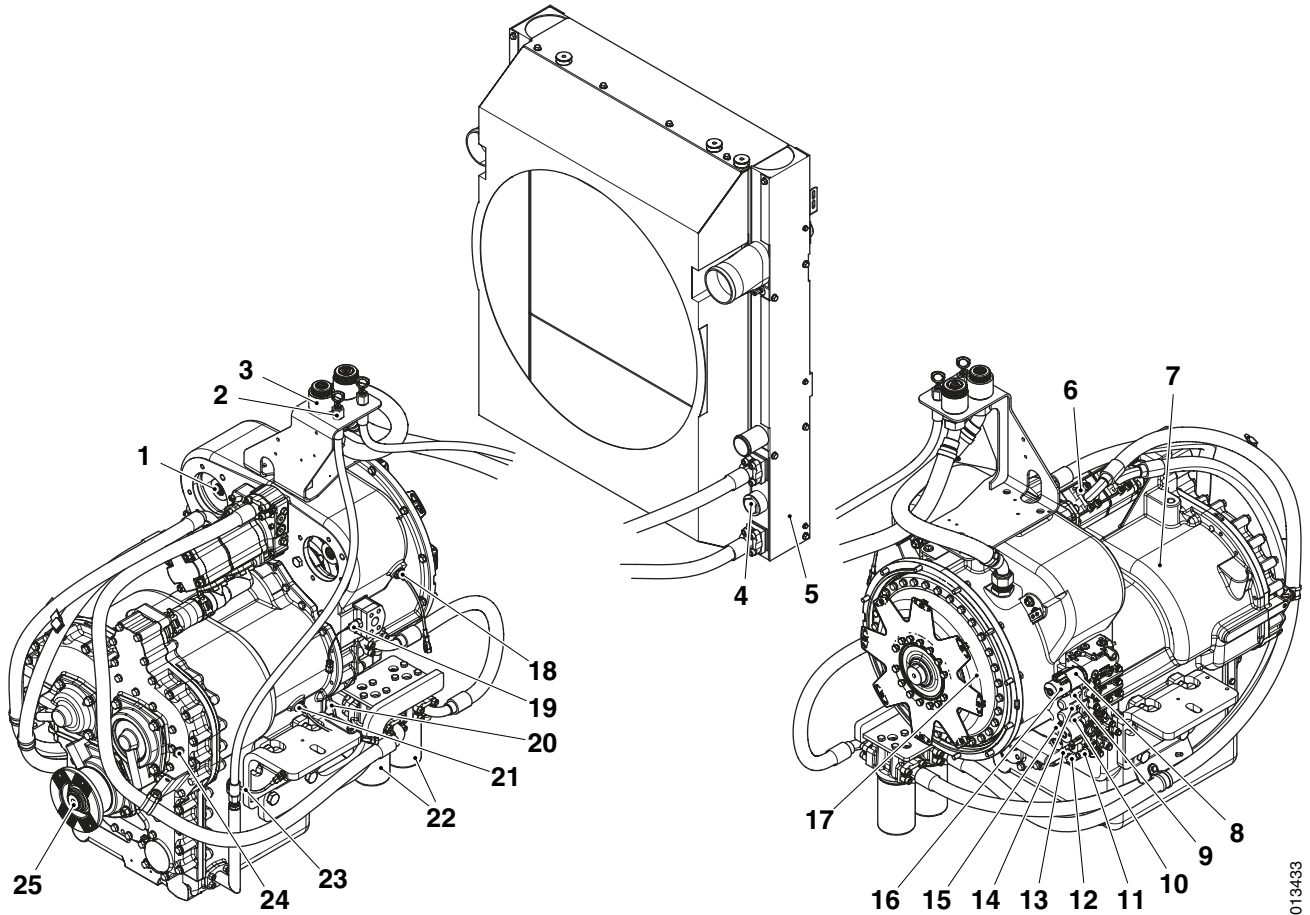

013433

- | | |
|---|--|
| 1. Power take-off | 14. Servo valve gear 2/4 (Y6069) |
| 2. Dipstick | 15. Solenoid valve gear selection 2/4 (Y6074) |
| 3. Filling of transmission oil | 16. Solenoid valve drive reverse (Y6066R) |
| 4. Thermostat | 17. Torque converter |
| 5. Transmission oil cooler | 18. Sensor engine speed (B7530) |
| 6. Oil pump transmission | 19. Temperature switch, torque converter (S2210) |
| 7. Gearbox | 20. Turbine speed sensor (B7510) |
| 8. Solenoid valve drive forward (Y6066F) | 21. Sensor, drum rpm (B7520) |
| 9. Servo valve gear forward/reverse (Y6300) | 22. Oil filter transmission |
| 10. Servo valve gear 1/3 (Y6067) | 23. Sensor rpm output shaft (B7580) |
| 11. Solenoid valve gear selection 1/3 (Y6075) | 24. Sensor oil temperature (B7660) (from radiator to sump) |
| 12. Pressure sensor gear 1/3 (B6067) | 25. Output shaft |
| 13. Pressure sensor gear 2/4 (B6069) | |

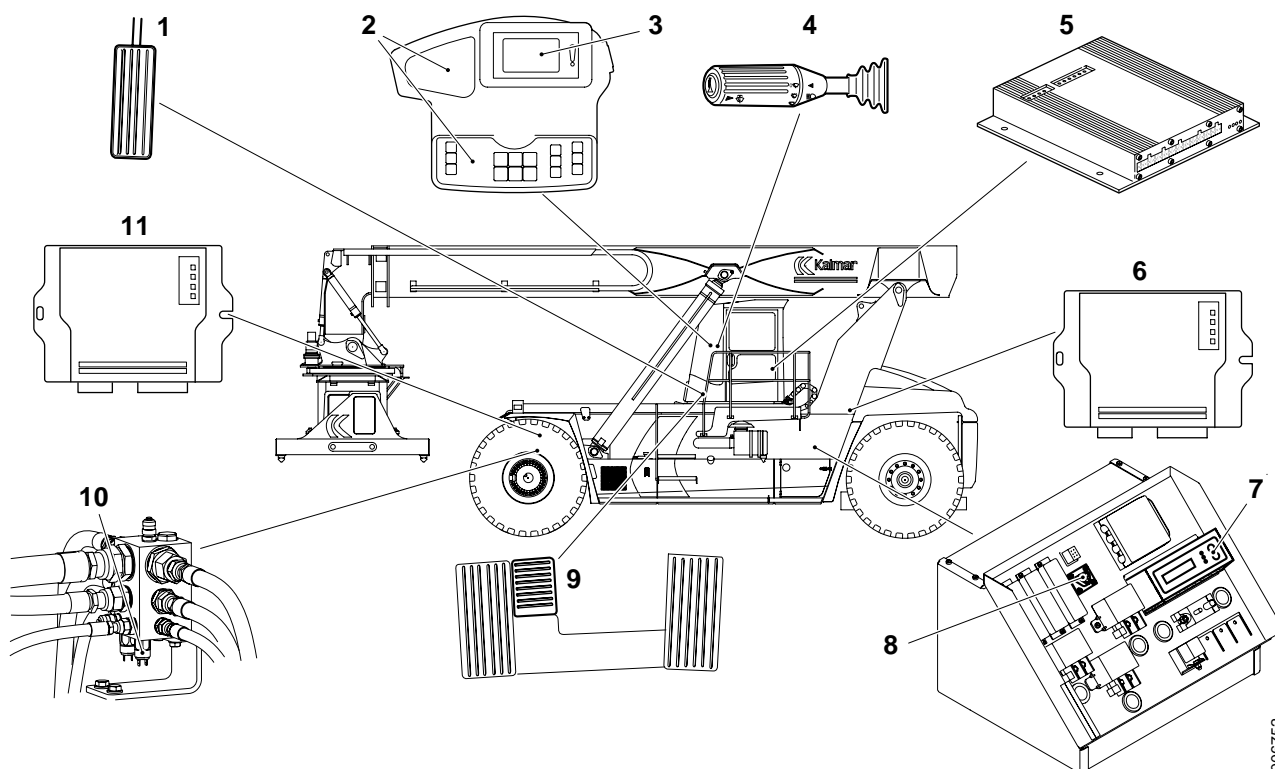

006762

- | | |
|-------------------------------------|---------------------------------------|
| 1. Accelerator pedal (B690) | 7. Transmission control unit (D793) |
| 2. Control unit KIT (D790-2) | 8. Diagnostic socket, transmission |
| 3. Control unit KID (D795) | 9. Declutch pedal (S220-1) |
| 4. Multi-function lever (S162) | 10. NO switch, declutch (S220-2) |
| 5. Control unit cab (D790-1) | 11. Control unit frame front (D797-F) |
| 6. Control unit frame rear (D797-R) | |

Engine and transmission, separation

Engine alternative Volvo: see section 1 Engine , group 1 Engine and transmission separation (Engine alternative Volvo).

Engine alternative Cummins: see section 1 Engine , group 1 Engine and transmission separation (Engine alternative Cummins).

2.1 Controls and instruments

2.1.1 Gear selector and multi-function lever

Gear and multi-function lever, description

Travel direction is selected with the gear and multi-function lever.

Selection of travel direction:

- F – Forward
- N – Neutral
- R – Reverse

The switch is supplied voltage by and sends signals to the KIT control unit (D790-2).

The signal can be checked from the diagnostic menu, see section 8 *Control system* , group 8.4.7.2 *TRANSM, menu 2*.

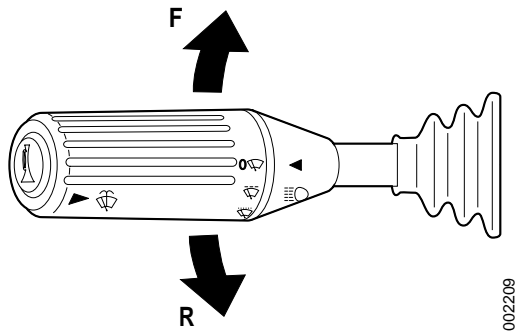

2.2 Torque converter/Clutch system

2.2.1 Flex plates

Flex plates, replacement (engine alternative Volvo)

- 1 Machine in service position, see section *B Safety*.
- 2 Remove the cover plate for the flywheel.



- 3 Remove the bolts for the flex plate.





- 4 Turn the engine for each bolt to be removed from the flex plate.
- 5 Attach the transmission to an overhead crane.
- 6 Remove the bolts holding together the transmission and engine.



- 7 Carefully separate the transmission and engine.



Flex plate attachment.

- 8 Remove the bolts holding the flex plate to the transmission.
- 9 Replace the flex plate.
- 10 Fit in the reverse order. Fit the attaching bolts with **40 Nm**.
- 11 Before the machine is put into operation, the transmission must be calibrated; see *Transmission, calibration page 32*.

Flex plates, replacement (engine alternative Cummins QSM11)

- 1 Machine in service position, see section *B Safety*.
- 2 Remove the cover plate.
- 3 Remove the bolts for the flex plate.



- 4 Turn the engine for each bolt to be removed from the flex plate.
- 5 Attach the transmission to an overhead crane.
- 6 Remove the bolts holding together the transmission and engine.



7 Carefully separate the transmission and engine.



8 Remove the bolts holding the flex plate to the transmission.

9 Replace the flex plate.

10 Fit in the reverse order. Fit the attaching bolts with **40 Nm**.

11 Before the machine is put into operation, the transmission must be calibrated; see *Transmission, calibration page 32*.

Flex plate attachment.

2.6 Lubrication system

Lubrication system, description

The transmission lubricating system has the following function:

- Lubricate gear wheel and bearings
- Apply the clutches in the transmission
- Cool down the torque converter and the transmission
- Clean the oil of any impurities with two oil filters.

During operation of the engine, the oil pump draws oil from the transmission's oil sump through a strainer, and it then pumps it through two oil filters to a control valve.

The control valve supplies oil at the correct pressure to the transmission's valve housing to activate the clutch plates for FORWARD or REVERSE and gear 1, 2, 3 or 4. The clutch plates require just a small amount of the oil flow supplied by the pump. The remainder of the oil is pumped through the torque converter circuit to the oil cooler and returns to the transmission for lubrication.

See also *supplier documentation, transmission*.

Oil and oil filter, changing

NOTE

Read the safety instructions for oil before working, see section B Safety.

NOTE

The transmission must not be over filled!

- 1 Operate and warm up the transmission oil.
- 2 Machine in service position, see section *B Safety*.
- 3 Remove the drain plug for transmission oil and let the oil drain into the receptacle.



Draining transmission oil



Oil filter transmission

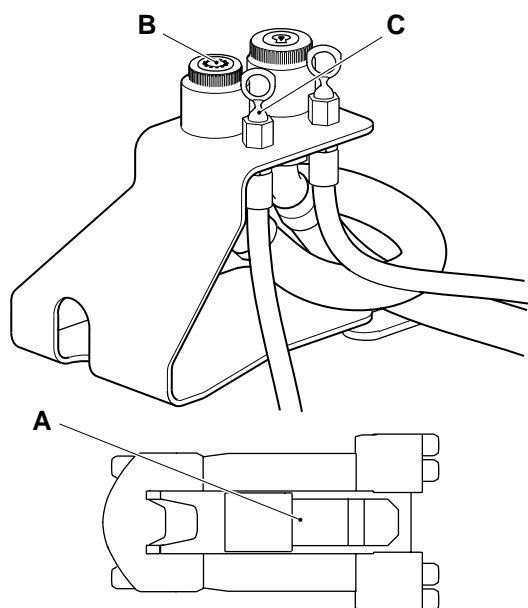

013334

- A. Location of filler orifice and level control
 B. Filling
 C. Dipstick

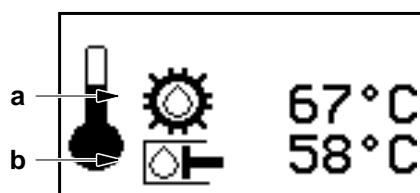

000356

- Operating menu, oil temperature
 a. Transmission oil temperature
 b. Hydraulic oil temperature

- 4 Change oil filter.
 Moisten the O-ring of the new oil filters with transmission oil. Tighten until it makes contact and then another two-thirds of a turn.
- 5 When the transmission oil has drained, fit the drain plug.
 Make sure that the washer for the oil plug is included.

- 6 Fill with new transmission oil through the filler orifice (position B).
 For volume and grade, see section *F Technical data*.
- 7 Start the engine and allow it to idle for at least two minutes.
- 8 Check that the transmission oil drain plug is airtight.
- 9 Check the transmission oil level with the engine running at idle and top up to the marking for low level.

- 10 Warm up the transmission so that the display shows an oil temperature between 60-65 °C. Use the oil temperature operating menu to check transmission oil temperature.
- 11 Check the oil level. Fill to the MAX mark.

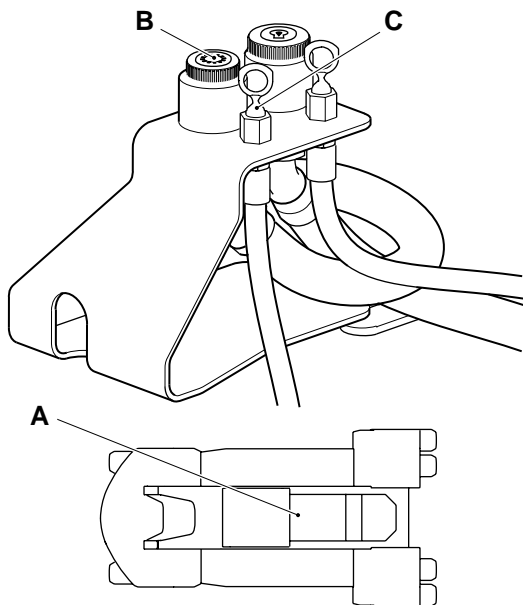

- A. Location of filler orifice and level control
 B. Filling
 C. Dipstick

Oil level, check

NOTE

Read the safety instructions for oil before working, see section B Safety.

The transmission's oil filler pipe and dipstick (position B) are located under the service hatch in front of the cab.

- 1 Check the oil level with the engine at idle, transmission in neutral position and at operating temperature (approx. 60-65 °C in the display). The dipstick has two markings, MAX and MIN. The oil level should be at MAX.

Wipe off the dipstick before checking.

NOTE

The oil dipstick is long. Wear gloves.

- 2 Fill transmission oil (position B) if required (for volume and grade, see section F Technical data).

Fill – wait a moment – check the dipstick.

NOTE

Work carefully when filling transmission oil to prevent other fluids or particles from contaminating the oil, which means risk of transmission damage.

013334

2.6.3 Oil cooler

Oil cooler, description

The transmission oil is cooled in the lower section of the cooling unit.

A temperature-controlled bypass valve, which only acts on the transmission oil cooling circuit, is located in a pipe on the underside of the cooler (engine side). The valve closes when the oil starts to reach working temperature. This means that the oil reaches normal working temperature more quickly.

For more detailed information, see *supplier documentation, transmission*.

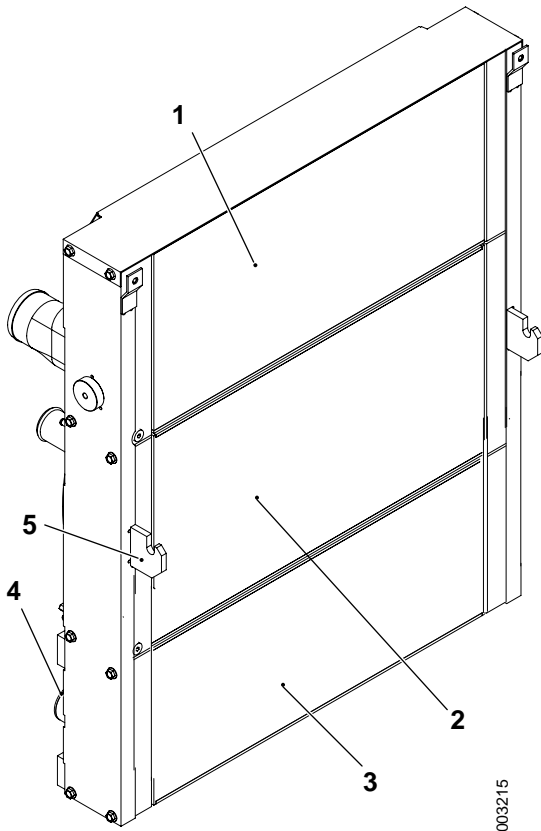

Cooling unit, engine alternative Cummins QSM11 and Volvo TAD1250VE

1. Intercooler
2. Radiator, engine
3. Transmission oil cooler
4. Transmission oil thermostat
5. Condenser mounting (to AC)

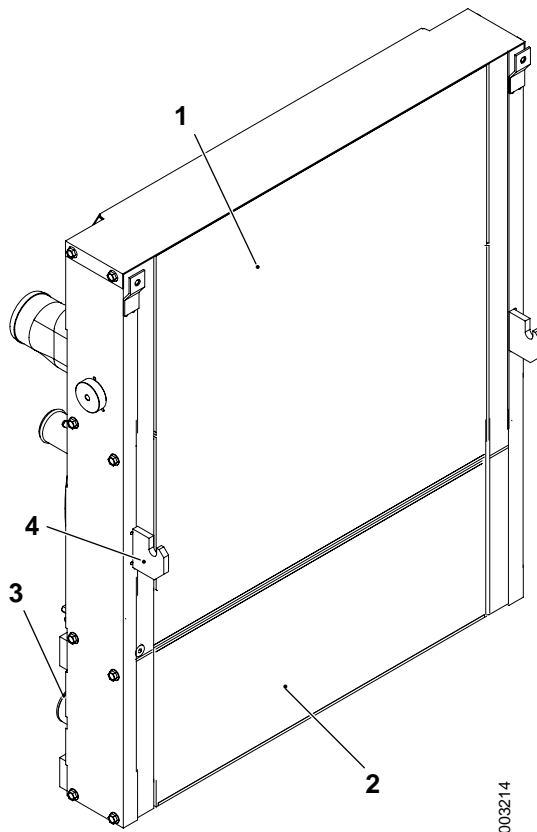

Cooling unit, engine alternative Volvo TWD1240VE

1. Radiator, engine
2. Transmission oil cooler
3. Transmission oil thermostat
4. Condenser mounting (to AC)

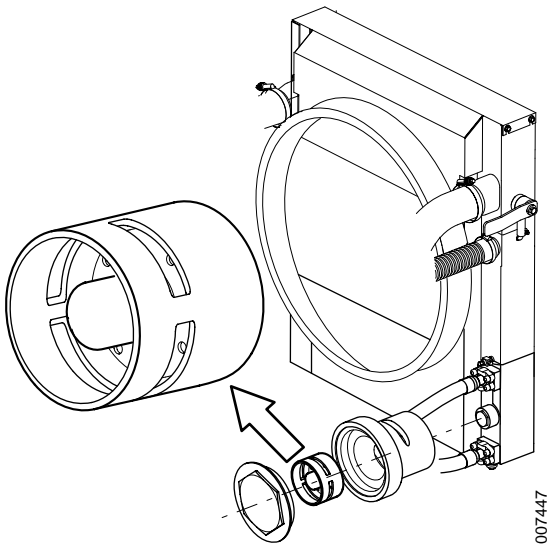

Thermostat transmission oil cooler, changing

NOTE

Read the safety instructions for oil before working, see section B Safety.

- 1 Machine in service position, see section B Safety.
- 2 Drain the oil from the transmission, see *Oil and oil filter, changing page 26*.
- 3 Loosen the cover plug and remove the thermostat.
- 4 Check the O-ring and the spring in the bottom, change as needed.
- 5 Install the new thermostat, and the cover plug.

IMPORTANT

It is very important that the thermostat is used with the temperature bulb facing out as shown.

- 6 Fill with transmission oil; see *Oil and oil filter, changing page 26*.
- 7 Start the engine and check for leaks.
- 8 Check the transmission oil level; see *Oil level, check page 28*.

2.7 Cooling system

2.7.3 Oil cooler

Oil cooler, description

See Oil cooler, description page 29.

2.8 Transmission control system

Transmission, calibration

See section 8 *Control system*, group 8.5.2.3 *Calibrate DRIVE-TRAIN*.

2.8.1 Control unit transmission

Transmission control unit, general

See section 11 *Common electrics*, group 11.5.3.9 *Transmission control unit* and *Supplier documentation*.

2.8.2 Normally closed (NC) switch, disengagement

Normally closed (NC) switch, disengagement, description

The NC switch for disengagement detects if the wheel brakes are pressurised. The NC switch is located on the distribution block for the brake system, above the drive axle's differential.

The sensor can be checked from the diagnostic menu, see section 8 *Control system*, group 8.4.7.1 *TRANSM, menu 1*.

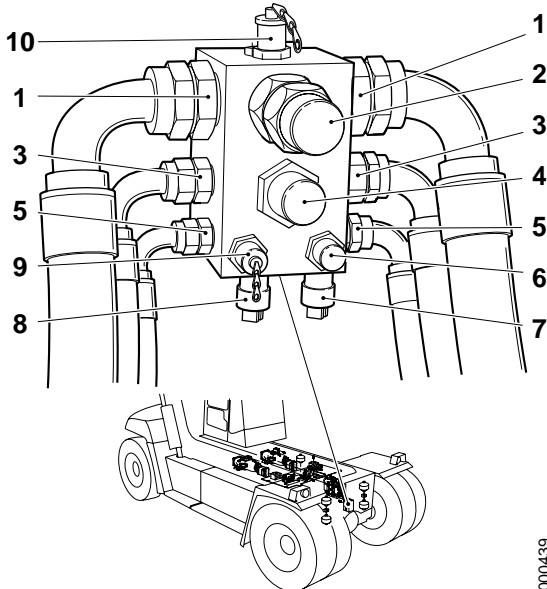

1. Brake cooling connection, return from wheel brake
2. Brake cooling connection, return to cooler and tank
3. Brake cooling connection, to wheel brake
4. Brake cooling connection from accumulator charging valve
5. Brake cylinder connection, to wheel brake
6. Brake pressure connection, from brake valve
7. NO switch, declutch (S220)
8. NO switch, brake lights (S216)
9. Measuring outlet, brake pressure
10. Measuring outlet, brake cooling back pressure

2.8.3 Transmission cable harness

Transmission cable harness, description

See section E *Schematics*.

Table of Contents 3 Driveline/Axle

3	Driveline/axle	3
3.2	Propeller shaft	3
3.3	Drive axle	4

3 Driveline/axle

3.2 Propeller shaft

Propeller shaft, description

The propeller shaft transfers engine power from the transmission to the drive axle. The propeller shaft has two joints, which means that the engine and drive axle can move in relation to each other.

Propeller shaft, replacement

- 1 Machine in service position, see section *B Safety*.
- 2 Clean the contact surfaces (cross-toothed) on the drive axle and transmission.



- 3 Fit the propeller shaft in position with the coupling upward.
- 4 Fit the propeller shaft attaching bolts.
Tightening torque **156 Nm**. Retighten the attaching bolts after 50 hours of operation.

3.3 Drive axle

Drive axle, general

Component supplier documentation

The workshop manual only describes components and work descriptions related to installation in the machine. Please refer to the component supplier documentation for descriptions and instructions of drive axle components and systems.

References to supplier documentation are only used in exceptional cases. If information about a component is missing, use the supplier documentation.

Drive axle, replacement

DANGER

Drive axle and machine are very heavy.

Risk of pinch injury!

Do not go under a machine which has been lifted by a jack etc under any circumstances. For machine weights, please refer to section *F Technical data*



- 1 Park the machine with blocks behind the steering wheels.
- 2 Depressurise the brake and hydraulic systems, see section *B Safety*.
- 3 Turn the start key to position 0 and turn off the main electric power.

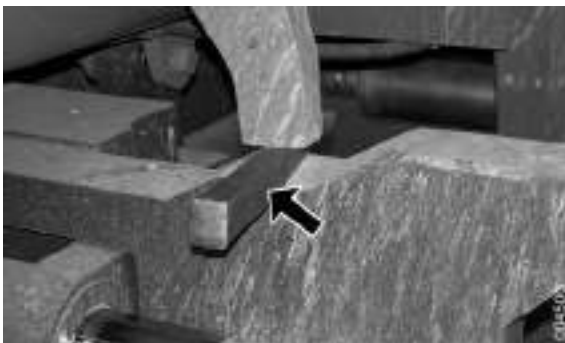

- 4 Install wedges between the steering axle and frame.

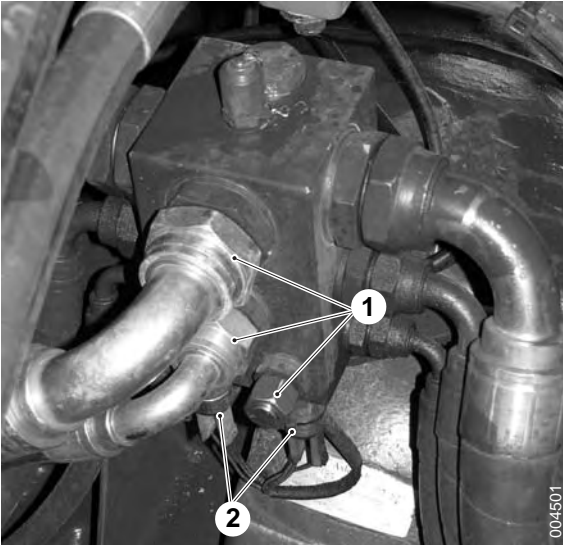

1. Hydraulic hoses
2. Cables

- 5 Disconnect hydraulic hoses (position 1) and cabling (position 2) from the distribution block.

NOTE

Plug all unions at once to protect the hydraulic system from contamination.



3. Casing parking brake

- 6 Remove the casing (position 3) on the parking brake.

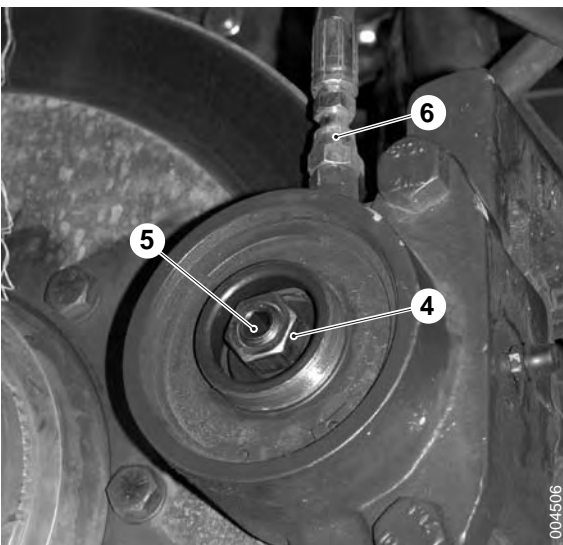

4. Lock nut
5. Release screw
6. Hydraulic hose, parking brake

- 7 Loosen the lock nut (position 4) and screw in the screw (position 5), this compresses the brake spring. Screw until the brake pads release from the brake disc. Reinstall the casing on the parking brake (position 3).
- 8 Disconnect the hydraulic hose (position 6) from the parking brake.

NOTE

Plug all unions at once to protect the hydraulic system from contamination.



Securing propeller shaft.

- 9 Disconnect the propeller shaft from the drive axle. Secure the propeller shaft, otherwise there is a risk that it will be pulled apart.

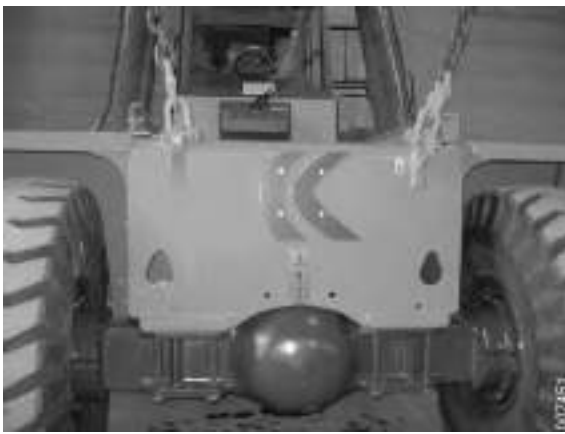

Lifting the machine

- 10 Lift the machine so that the wheels are off the ground.
- 11 Remove the drive wheels from the drive axle.
- 12 Block up the drive axle under the hubs.

CAUTION

The drive axle may start to roll.

Crushing injury!

Make sure that the drive axle does not roll away when not under control.

- 13 Remove the bolts that secure the drive axle in the frame.
- 14 Lift away the drive axle.

CAUTION

The drive axle may start to roll.

Crushing injury!

Make sure that the drive axle does not roll away when not under control.

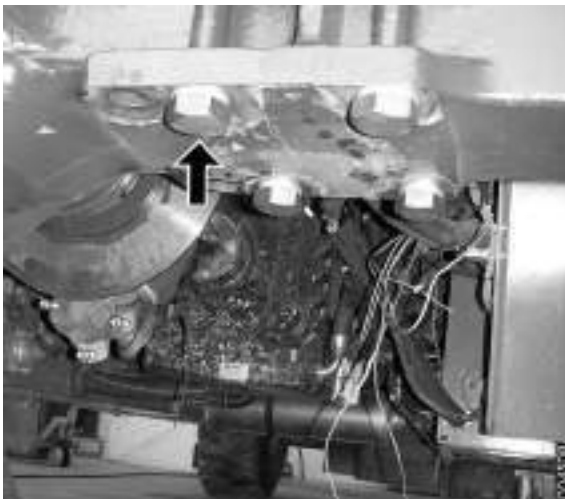

Attaching bolts, drive axle

- 15 Transfer parts from the old drive axle to the new one.

NOTE

Plug all unions at once to protect the hydraulic system from contamination.

- 16 Clean the contact surfaces on the drive axle and frame. Also clean the bolts' contact surface on the underside of the drive axle.

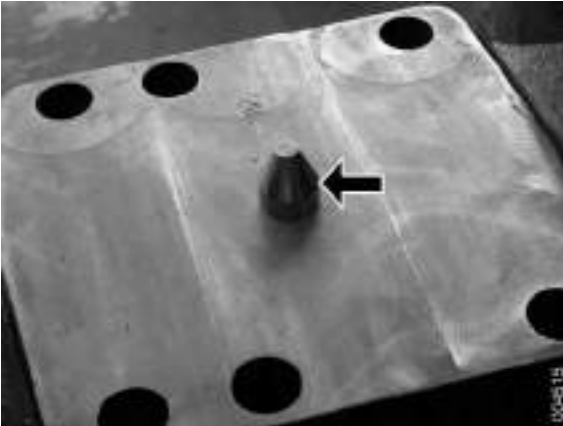

- 17 Remove the nuts for attaching the drive axle, blow clean and re-install the nuts.
- 18 Transfer the guide pins from the old axle to the new axle.
- 19 Lift the drive axle into place under the frame.

CAUTION

The drive axle may start to roll.

Crushing injury!

Make sure that the drive axle does not roll away when not under control.

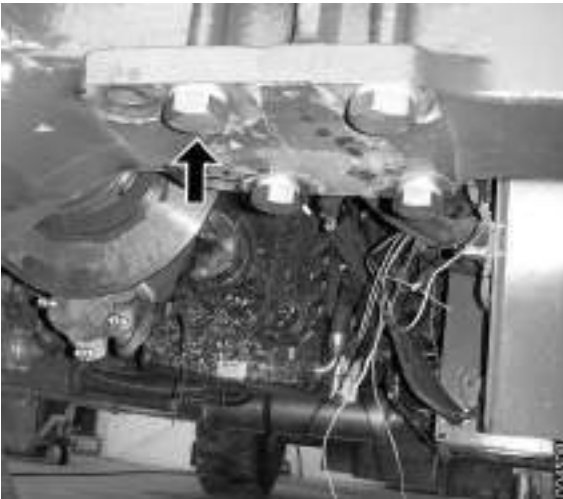

- 20 Lower the frame toward the drive axle. Check that the guide pins fit in the frame.
- 21 Fit the new bolts that secure the drive axle in the frame. Tighten the bolts to a torque of **2820 Nm**.
- 22 Install the drive wheels on the new axle.
- 23 Rustproof the bolts with suitable paint.

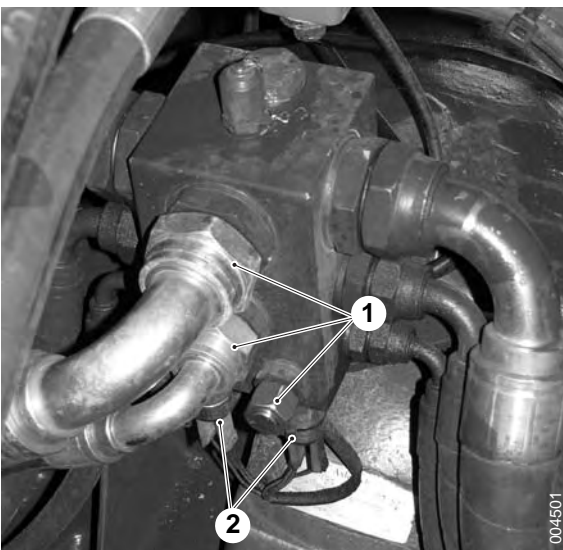

- 24 Connect hydraulic hoses (position 1) and cabling (position 2) to the distribution block on the drive axle.
- 25 Connect the hydraulic hose to the parking brake, adjust the parking brake.
- 26 Connect the drive shaft to the drive axle, tighten the bolts to a torque of **156 Nm**. (Retighten the attaching bolts after 50 hr operating time).
- 27 Check the oil level in the drive axle.
- 28 Start the machine and bleed the brakes; see section *4 Brakes*, group *4.3.9 Wheel brake*.
- 29 Check for leaks.

Table of Contents 4 Brakes

4	Brakes	3
4.1	Controls and instruments	3
4.1.1	Brake pedal	3
4.3	Power-assisted brake system	5
4.3.1	Brake fluid pump	7
4.3.2	Brake fluid filter	12
4.3.3	Accumulator charging valve	13
4.3.4	Accumulator	16
4.3.5	Brake valve	20
4.3.6	Drive axle block	24
4.3.7	NC switch, brake fluid pressure	25
4.3.8	NO (normally open) switch, brake lights	26
4.3.9	Wheel brake	28
4.3.10	Pipes and hoses	30
4.5	Parking brake system	31
4.5.1	Brake fluid pump	32
4.5.2	Brake fluid filter	32
4.5.3	M-valve parking brake	33
4.5.4	Parking brake unit	34
4.5.5	Parking brake NC switch	37
4.5.6	Pipes and hoses	37
4.8	Temperature control, cleaning and brake oil	38
4.8.1	Brake fluid tank	39
4.8.2	Tank heater	40
4.8.3	Brake fluid pump	40
4.8.4	Accumulator charging valve	40
4.8.5	Drive axle block	40
4.8.6	Wheel brake	40
4.8.7	Oil cooler	41
4.8.8	Cooling fan	42
4.8.9	Thermal bypass valve	42
4.8.10	Sensor brake oil temperature	43
4.8.11	Breather filter	44
4.8.12	Brake fluid filter	45
4.8.13	Pipes and hoses	46
4.8.14	Brake system fluid	46

4 Brakes

4.1 Controls and instruments

4.1.1 Brake pedal

Brake pedal, checking and adjusting

- 1 Clean the floor round the brake pedal and check that nothing is obstructing the movement of the brake pedal.
- 2 Check that the brake pedal springs back adequately and that the clearance between brake pedal and brake valve is 1–1.5 mm. If needed, adjust the brake pedal's stop bolt to correct clearance.
- 3 Check that the pedal moves easily.

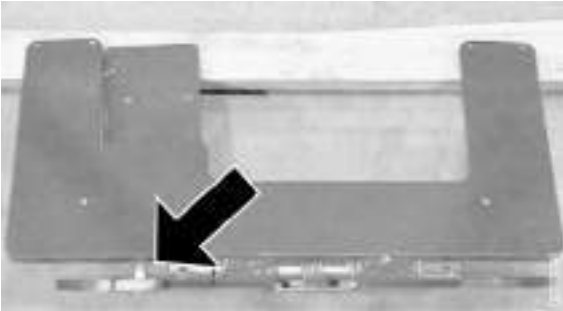

Stop screw for adjusting clearance between brake pedal and brake valve. (The illustration shows a loose brake pedal.)

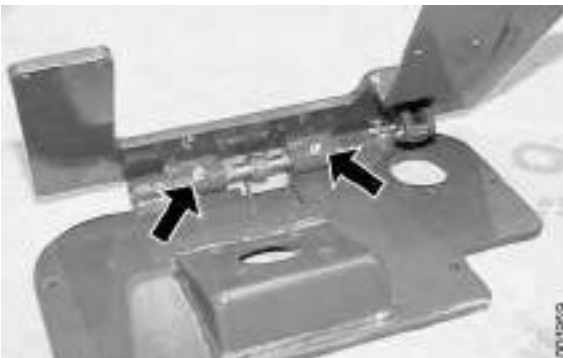

Lubrication points, brake pedal. (The illustration shows a loose brake pedal.)

- 4 Lubricate the pedal hinge with "EP2" universal grease.
- 5 Check that the rubber pad on the brake pedal is intact and that the pattern is not worn away. Replace as necessary.
- 6 Check the brake valve; see *Brake valve, checking page 20*.

Brake pedal, replacement

NOTE

Read the safety instructions for oil before working, see section B Safety.

- 1 Turn off the engine and the main electrical power.
- 2 Depressurise the brake and hydraulic systems, see section *B Safety*.
- 3 Detach the brake valve from the brake pedal.
Secure the brake valve on the cab's underside and remove the brake valve attaching bolt.



- 4 Remove the panel around the steering wheel shaft.

NOTE

There is a variant available with adjustable steering wheel shaft.

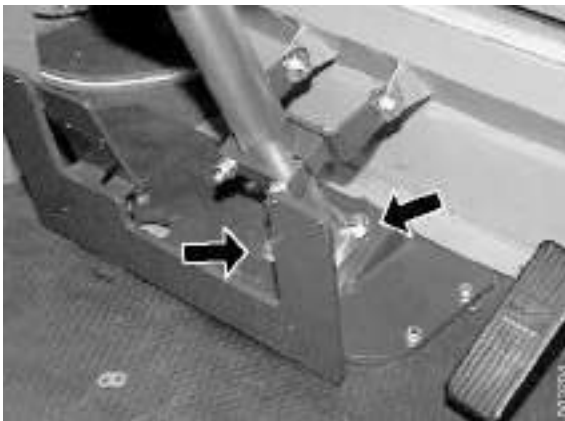

Mounting of steering wheel shaft and steering valve in pedal bracket.

- 5 Detach the steering valve from the pedal bracket.
Secure the steering valve on the cab's underside. Remove the steering valve's attaching bolts. Pull down the valve slightly so that the steering axle releases from the steering valve.
- 6 Detach the steering wheel shaft from the brake pedal.
Undo the bolts and pull the steering wheel shaft up slightly so that the brake pedal can be removed.
- 7 Detach the clutch-release pedal from the brake pedal.
- 8 Remove the brake pedal.
Remove the brake pedal's attaching bolt and lift away the brake pedal.
- 9 Transfer the pedal rubber to the new pedal.
- 10 Fit the new brake pedal.
Fit the pedal and fit the pedal's attaching bolts.
- 11 Connect the steering valve to the brake pedal.
- 12 Connect the brake valve to the brake pedal.
- 13 Fit the clutch pedal to the brake pedal.
- 14 Close the drain valve on the accumulator charging valve.

NOTE

Check that the accumulator drain valve is fully closed and tighten the lock ring.

- 15 Grease and adjust the brake pedal, see *Brake pedal, checking and adjusting* page 3.



Pos	Explanation	Signal description	Reference
6	The brake cylinders compress the discs in the brake unit.	See the pressure plate, Brake pressure, on left-hand frame member.	<i>Wheel brake, description page 28</i>
7	The wheel brakes brake the machine.	-	<i>Wheel brake, description page 28</i>
8	The brake light NO switch (S216) closes the circuit when the brake cylinders are pressurised.	Brake pressure above 0.2 MPa: Conn 1, U = 24 V Conn 2, U = 24 V Brake pressure below 0.2 MPa: Conn 1, U = 24 V Conn 2, U = 0 V	<i>Switch normally open (NO), brake lights, description page 26</i> D8: Diagnostic menu, see section 8 <i>Control system</i> , group 8.4.5.4 <i>HYD</i> , menu 4
9	Control unit, frame front (D797-F) transmits the brake light request on the CAN bus.	Checked by control system, error shown with error code.	Section 11 <i>Common electrics</i> , group 11.5.3.2 <i>Control unit, frame front</i>
10	The brake lights are activated by Control unit, frame rear (D797-R).	U = 24 V	Section 9 <i>Frame, body, cab and accessories</i> , group 9.6.4 <i>Brake lights</i> D10: Diagnostic menu, see section 8 <i>Control system</i> , group 8.4.2.11 <i>LIGHTS</i> , menu 11
11	NC switch, brake oil pressure (S204) opens the circuit if the pressure in the accumulators is low.	Brake pressure above 11.5 MPa: Conn 1, U = 24 V Conn 2, U = 24 V Brake pressure below 11.5 MPa: Conn 1, U = 24 V Conn 2, U = 0 V	<i>NC switch, brake oil pressure, description page 25</i> D11: Diagnostic menu, see section 8 <i>Control system</i> , group 8.4.5.4 <i>HYD</i> , menu 4
12	Control unit, frame front (D797-F) transmits a warning about low brake pressure on the CAN bus.	Checked by control system, error shown with error code.	Section 11 <i>Common electrics</i> , group 11.5.3.2 <i>Control unit, frame front</i>
13	Control unit KIT (D790-2) activates Warning light brake pressure.	Checked by control system, error shown with error code.	Section 11 <i>Common electrics</i> , group 11.5.3.11 <i>Control unit KIT</i>

Hydraulic diagram, basic machine

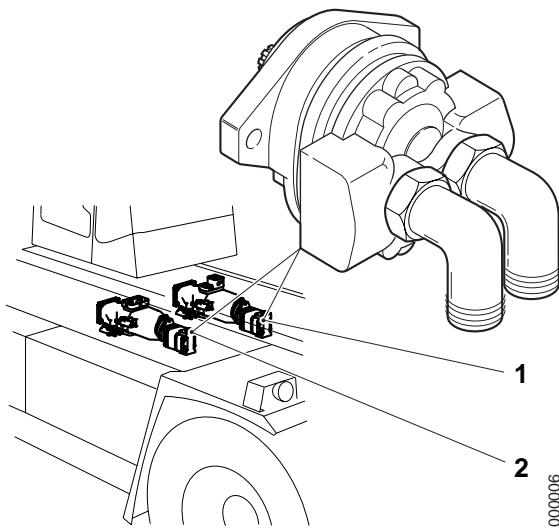

1. Brake fluid pump
2. Pump cooling and filtering, working hydraulics

4.3.1 Brake fluid pump

Brake fluid pump, description

The brake system has a gear pump with fixed displacement. The brake oil pump is fitted at the front of the left-hand main pump. The pump generates hydraulic power, which is stored in the accumulators for brake force to the power-assisted brake and parking brake. It also generates the oil flow used for cleaning and cooling. The switchover between power generation and flow is regulated by the accumulator charging valve, see *Accumulator charging valve, description page 13*.

The brake oil pump is driven by the main pump's shaft from gearbox power take-off. The brake oil pump's speed is directly dependent on engine speed. The pump flow rate increases with engine speed and varies with the speed of the input shaft.

NOTE

It is very important that the clearance between the gears and between the gear and the housing is correct. Clearance that is too small creates wear damage. Clearance that is too large reduces the pump's power output.

Brake fluid pump, check

NOTE

Read the safety instructions for oil before working, see section B Safety.

Checking pump pressure

- 1 Operate and warm up the machine so that the oil in the brake system reaches operating temperature, at least 50 °C.
- 2 Machine in service position, see section *B Safety*
- 3 Depressurise the brake and hydraulic systems, see section *B Safety*.
- 4 Connect a pressure gauge (0–25 MPa) to the pump pressure measuring outlet on the accumulator charging valve.
- 5 Start the engine and run it at idling speed.

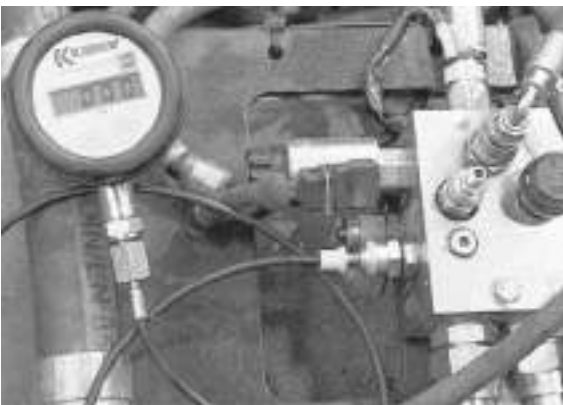

Measuring outlet, pump pressure



Close the accumulator charging valve

- 6 Close the drain valve on the accumulator charging valve and check the pump pressure during charging.

During charging the pressure should increase to **20.5 ±1.0 MPa** before the accumulator charging valve switches to cooling. When the accumulator charging valve switches to cooling, the pressure drops.

- 7 Check the pressure during cooling.

During cooling the pressure should be **max. 1.0–1.5 MPa** at max. engine rpm.

- 8 Stop the engine

- 9 Depressurise the brake and hydraulic systems, see section *B Safety*.

- 10 Remove the pressure gauge and fit the protective cap on the measuring outlet.

- 11 Close the drain valve on the accumulator charging valve.

Checking accumulator charging

- 12 Depressurise the brake and hydraulic systems, see section *B Safety*.

- 13 Connect a pressure gauge (0–25 MPa) to the measuring outlet for accumulator pressure on the accumulator charging valve.

- 14 Start the engine and run it at idling speed.

- 15 Close the drain valve on the accumulator charging valve.

- 16 Check that the pressure increases slowly to **20.5 ±1.0 MPa**.

- 17 Brake repeatedly and check at which pressure the accumulator charging valve switches to charging.

The valve must switch to cooling at **15.5 ±0.5 MPa**.

- 18 Depressurise the brake and hydraulic systems, see section *B Safety*.

- 19 Remove the pressure gauge and fit the protective cap on the measuring outlet.

- 20 Close the drain valve on the accumulator charging valve.

NOTE

Check that the accumulator drain valve is fully closed and tighten the lock ring.



Measuring outlet, accumulator pressure



Brake oil pump, replacement (hydraulic oil pump alternative Rexroth)

NOTE

Read the safety instructions for oil before working, see section B Safety.

- 1 Machine in service position, see section B Safety.
- 2 Depressurise the brake and hydraulic systems, see section B Safety.
- 3 Mark up and detach the hydraulic hoses from the pump.

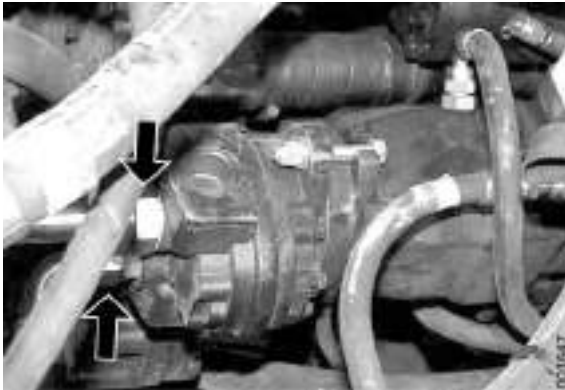

NOTE

Plug all connections immediately to protect the brake system from impurities.



- 4 Remove the attaching bolts, pull the pump out backwards and lift it away.
- 5 Transfer the connection adapters and the contact to the new pump.



- 6 Remove the spacer ring from the brake pump or hydraulic oil pump.
Clean the O-rings' contact surfaces on the spacer ring.
- 7 Check the O-rings and replace as required. Install the O-rings on the spacer ring. Brush sealing silicone on the sealing face against the brake pump, see section F Technical data.

NOTE

Only use silicone on the side facing the brake pump.



8 Fit the spacer ring on the main pump.



9 Brush sealing silicone on the brake pump's sealing face against the spacer ring; see section *F Technical data*.

10 Fit the brake pump on the main pump.

Fit the pump and check that the gear engages in the shaft and that the spacer ring is directly against the brake pump.

Fit the pump's attaching bolts.

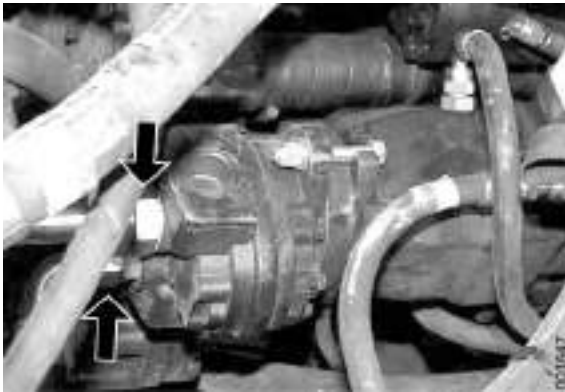

11 Connect the hydraulic hoses to the brake pump.

NOTE

Check that the O-rings are intact and are fitted correctly.



12 Close the drain valve on the accumulator charging valve.

NOTE

Check that the accumulator drain valve is fully closed and tighten the lock ring.

13 Turn on the main electric power and start the engine.

- 14 Check that the hose connections and seal between the hydraulic oil pump and brake pump are fully sealed.

Check the feed pressure from the brake pump, see *Brake fluid pump, check page 7*.

- 15 Check the oil level in the brake system, fill as necessary.

NOTE

If the pump is replaced due to malfunction, change the oil and filter in the brake system as well.

Brake oil pump, replacement (hydraulic oil pump alternative Sauer-Danfoss)

NOTE

Read the safety instructions for oil before working, see section B Safety.

- 1 Machine in service position, section B Safety.
- 2 Depressurise the brake and hydraulic systems, see section B Safety.
- 3 Mark up and detach the hydraulic hoses from the pump.

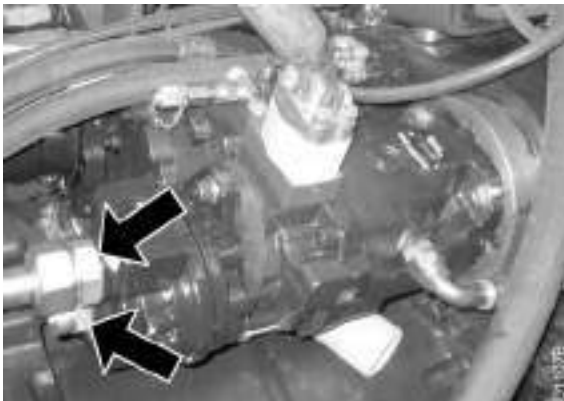

NOTE

Plug all connections immediately to protect the brake system from impurities.

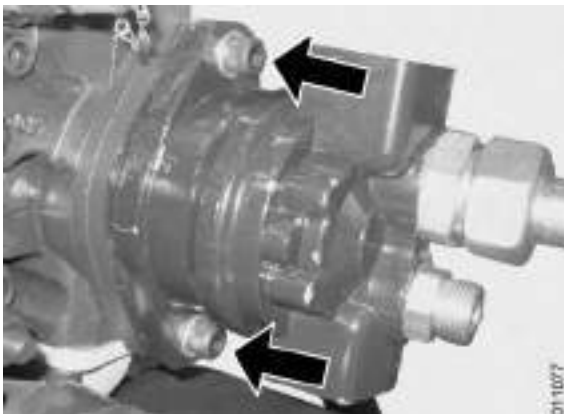

- 4 Remove the attaching bolts, pull the pump out backwards and lift it away.
- 5 Transfer the connection adapters and the contact to the new pump.



6 Brush sealing silicone on the brake pump's sealing face; see section *F Technical data*.

7 Fit the brake pump on the main pump.

Position the pump and check that the pump's splines engage in the shaft in the main pump.

Fit the pump's attaching bolts.

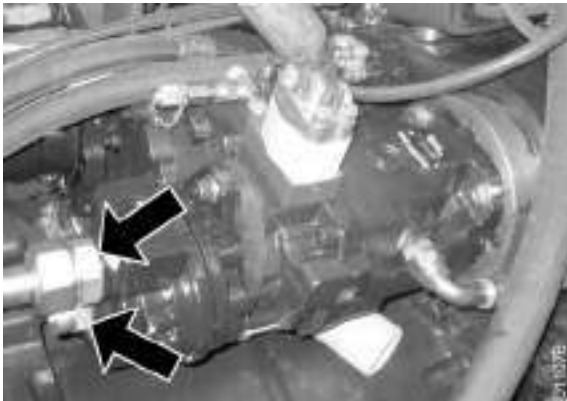

8 Connect the hydraulic hoses to the brake pump.

NOTE

Check that the O-rings are intact and are fitted correctly.



9 Close the drain valve on the accumulator charging valve.

NOTE

Check that the accumulator drain valve is fully closed and tighten the lock ring.

10 Turn on the main electric power and start the engine.

11 Check that the hose connections and seal between the hydraulic oil pump and brake pump are fully sealed.

Check the feed pressure from the brake pump, see *Brake fluid pump, check page 7*.

12 Check the oil level in the brake system, fill as necessary.

NOTE

If the pump is replaced due to malfunction, change the oil and filter in the brake system as well.

4.3.2 Brake fluid filter

Brake fluid filter, general

See *Brake fluid filter, description page 45*.

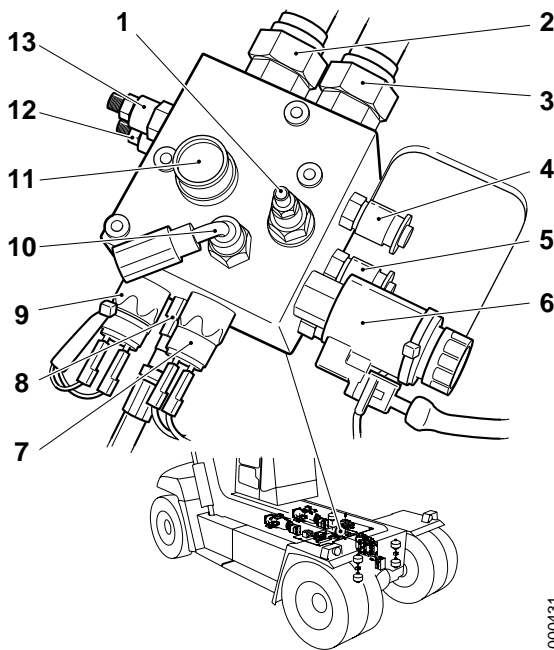

1. Safety valve
2. Connection from pump (P)
3. Wheel brake connection (T)
4. Measuring outlet, pump pressure (P)
5. Measuring outlet, accumulator pressure (M)
6. Solenoid valve parking brake (Y642)
7. NC switch, parking brake (GHB) (S200)
8. Connection, accumulators (ACC)
9. NC switch, brake fluid pressure (LB) (S204)
10. Connection, parking brake caliper (HB)
11. Drain valve
12. Main valve, charging
13. Pressure limiting valve

4.3.3 Accumulator charging valve

Accumulator charging valve, description

The accumulator charging valve distributes oil from the hydraulic oil pump between pressure storage and cooling of the wheel brakes. The accumulator charging valve is fitted on the beam in front of the gear-box in the engine compartment.

The accumulator charging valve stores pressure by guiding the oil to the accumulators. The wheel brakes are cooled by oil being guided to the drive axle cooling circuit and then on to the brake system cooler.

The accumulator charging valve prioritises charging of the accumulators above cooling. A restriction of the charging means that a small quantity of oil also flows to cooling during accumulator charging. At idling speed the flow from the pump is so small that all oil flows to pressure storage.

The drain valve (position 11) is used to relieve the pressure in the accumulators to the tank. The valve opens a connection between the accumulators and the wheel brake's cooling circuit. The oil is drained through the wheel brake to the tank.

There is a measuring outlet for measuring the accumulator pressure (position 5) and pump pressure (position 4) on the accumulator charging valve. The pressures are individual to each machine and each are specified on the pressure plate on the left-hand frame member, see section 10 *Common hydraulics*. The accumulator charging valve also houses the parking brake solenoid valve (position 6), brake fluid pressure NC switch (position 9) and parking brake NC switch (position 7).

- *Solenoid valve parking brake, description page 33*
- *NC switch, brake oil pressure, description page 25*
- *Parking brake NC switch, description page 37*

Accumulator charging, checking and adjustment

NOTE

Read the safety instructions for oil before working, see section B Safety.

- 1 Machine in service position, see section *B Safety*.
- 2 Check accumulator charging; see *Brake fluid pump, check page 7*.



Adjusting screw accumulator charging pressure



- 3 If necessary, adjust the accumulator charging pressure on the pressure limiting slide.
Undo the lock nut and adjust the pressure by turning the adjusting screw.
Clockwise: reduce pressure.
Counter-clockwise: increase pressure.
- 4 Open the drain valve on the accumulator charging valve so that the accumulators are drained and the valve switches to charging. Close the valves and check the max. pressure again.
- 5 Repeat steps 3 and 4 until the pressure is correct.
- 6 Close the drain valve on the accumulator charging valve.

NOTE

Check that the accumulator drain valve is fully closed and tighten the lock ring.

Accumulator charging valve, replacement**NOTE**

Read the safety instructions for oil before working, see section B Safety.

- 1 Machine in service position, see section B Safety.
- 2 Depressurise the brake and hydraulic systems, see section B Safety.
- 3 Mark up hydraulic hoses and electric cables.
- 4 Detach the wiring from the accumulator charging valve.
- 5 Detach and plug all hydraulic hoses from the accumulator charging valve.
Remove the parking brake valve (C) for easier access.

NOTE

Plug all connections immediately to protect the brake system from impurities.



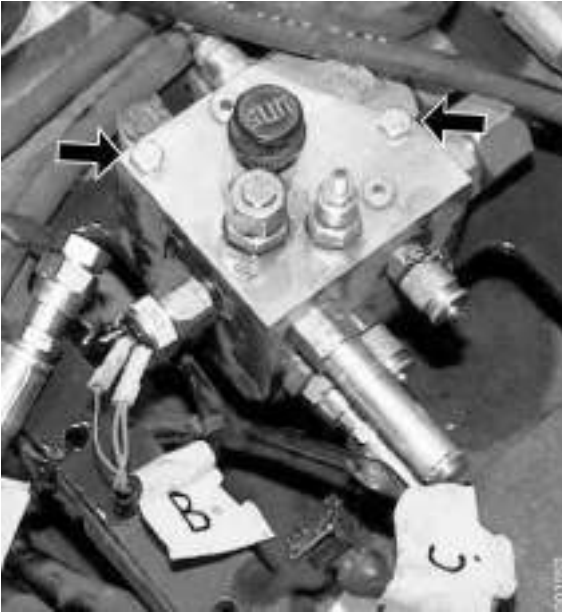

- 6 Remove the accumulator charging valve.
- 7 Transfer the connection adapters and sensors to the new accumulator charging valve.
- 8 Fit the new valve.



- 9 Connect the hoses to the accumulator charging valve in accordance with the marking.

NOTE

Check that the O-rings are intact and are fitted correctly.

- 10 Fit the parking brake valve and NC switch parking brake.
- 11 Connect the wiring to the accumulator charging valve.



- 12 Close the drain valve on the accumulator charging valve.

NOTE

Check that the accumulator drain valve is fully closed and tighten the lock ring.

- 13 Turn on the main electric power and start the engine.
Check that the hydraulic connections are sealed tightly.
- 14 Check the charging and changing function, see *Accumulator charging, checking and adjustment* page 13.

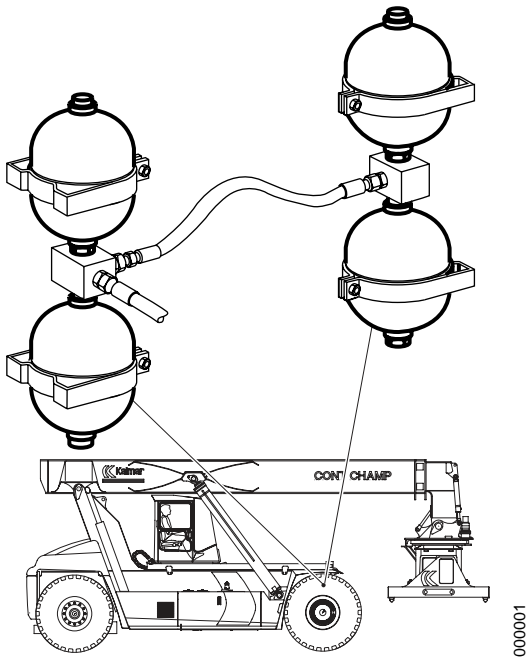

4.3.4 Accumulator

Accumulator, description

The accumulators store pressure so that there is a pressure reserve in the event of engine or brake system malfunction. The brake system has four accumulators connected in parallel. These are fitted at the front in the engine compartment, above the drive axle.

The accumulators are of the diaphragm type. Each accumulator is divided into two spaces by a diaphragm. One side of the diaphragm is pressurised by nitrogen gas. The other side is pressurised by the hydraulic oil, which compresses the nitrogen gas.

The accumulator has test outlets for checking the gas pressure on the opposite side to the pressure connection.

Accumulator, checking

NOTE

Read the safety instructions for oil before working, see section B Safety.

- 1 Machine in service position, see section B Safety.
- 2 Depressurise the brake and hydraulic systems, see section B Safety.
- 3 The accumulators can be tested with separate test equipment or in the machine. Primarily, separate test equipment should be used since it is faster and more accurate.

Test equipment can be ordered from Cargotec.

- **Check with test equipment:** continue with step 4.
- **Check in machine:** continue with step 6.

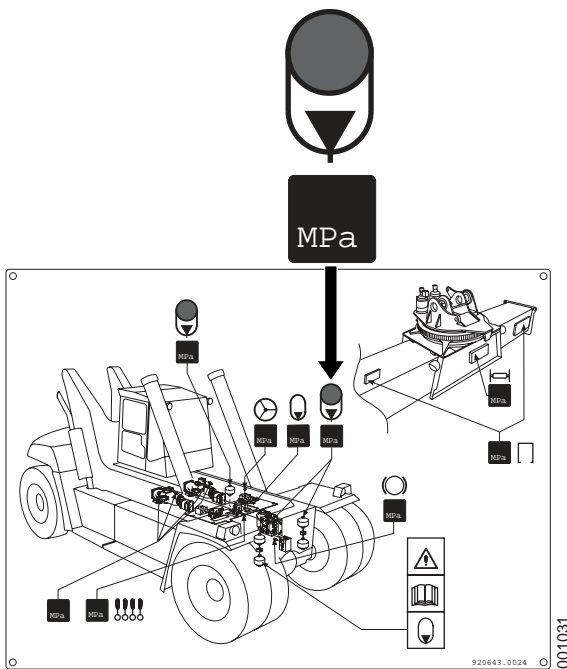

Pressure plate, gas pressure brake accumulators



Checking with test equipment

- 4 Remove the accumulators and test them with the intended test equipment.
The accumulators' gas pressure should match with the pressure plate.
- 5 Continue with step 17.

Checking in machine

- 6 Detach three of the accumulators from the distribution block. Plug the distribution block connections with plugs that can withstand high pressure. Plug the connections on the accumulators to protect against contamination.
- 7 Connect a pressure gauge (0–25 MPa) to the measuring outlet for accumulator pressure on the accumulator charging valve.
- 8 Turn on the main electric power and start the engine.
- 9 Close the drain valve on the accumulator charging valve and charge the accumulator until the accumulator charging valve changes to cooling.
- 10 Check that the plugs seal properly.
- 11 Stop the engine
- 12 Lower the pressure by means of braking carefully several times while checking the pressure on the pressure gauge.

When the pressure reaches **approx. 10 MPa** the pressure must decrease immediately to 0 MPa.

If the pressure drops immediately when the engine is shut off, then the accumulator does not have any pre-charge pressure. This indicates internal leakage and the accumulator must be changed.

If the pressure can be reduced slowly to a pressure below **10 MPa** then the precharge pressure is too low and the accumulator must be replaced or given to authorised personnel for maintenance.



- 13 Depressurise the brake and hydraulic systems, see section *B Safety*.
- 14 Mark up and disconnect the tested accumulator. Plug the connections. Connect one of the other accumulators to the distribution block.
- 15 Repeat steps 8 - 14 until all accumulators have been checked.
- 16 Depressurise the brake and hydraulic systems, see section *B Safety*.

Installing and final checking

- 17 Connect all accumulators to the distribution blocks. If needed, replace or fill defective accumulators.

NOTE

Check that the seals are intact and are fitted correctly.

- 18 Turn on the main electric power and start the engine.
- 19 Close the drain valve on the accumulator charging valve.

NOTE

Check that the accumulator drain valve is fully closed and tighten the lock ring.

- 20 Check that the accumulators' connections are sealed tightly.
- 21 When the accumulators are fully charged, shut off the engine and turn the start key to position I.
- 22 Check that at least **8** brake applications (pedal depressions) can be performed before the pressure drops to **10 MPa**.

At **11.5 MPa** the warning lamp for low brake pressure must come on.

Accumulator, replacement

NOTE

*Read the safety instructions for oil before working, see section *B Safety*.*

- 1 Machine in service position, see section *B Safety*.
- 2 Turn off the engine and the main electrical power.
- 3 Depressurise the brake and hydraulic systems, see section *B Safety*.





- 4 Detach the accumulator's clamp and remove the bolt.
- 5 Detach the accumulator from the distribution block.

NOTE

Hold the block firmly so that the other accumulator does not work loose.

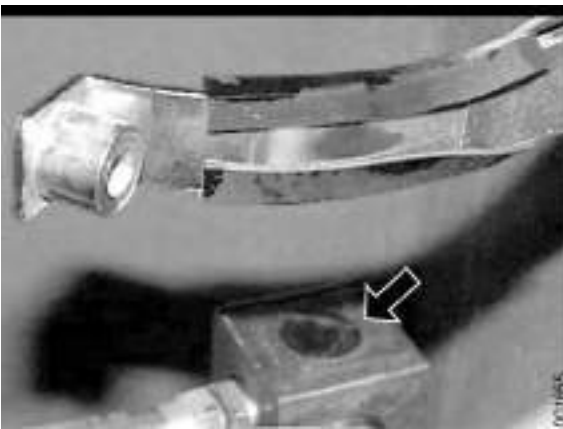

- 6 Bend the clamp away and remove the accumulator.



- 7 Fit the new accumulator.

NOTE

Check that the seal is intact and is fitted correctly.

- 8 Secure the accumulator's clamp and tighten the bolt.



- 9 Close the drain valve on the accumulator charging valve.

NOTE

Check that the accumulator drain valve is fully closed and tighten the lock ring.

- 10 Turn on the main electric power and start the engine.
- 11 Check that the accumulator's connection is sealed tightly.
- 12 Check precharging and function, see *Accumulator, checking* page 16 steps 18-19.

4.3.5 Brake valve

Brake valve, description

The brake valve, which is located on the underside of the cab underneath the brake pedal, controls the hydraulic pressure to the brakes. A lever transfers pedal force to the valve.

The brake valve is a mechanically activated proportional valve. This means that the resistance in the brake valve increases in proportion to brake pressure. This provides optimum pedal responsiveness and increased safety as the operator senses if no brake pressure is being built up (no resistance in the pedal).

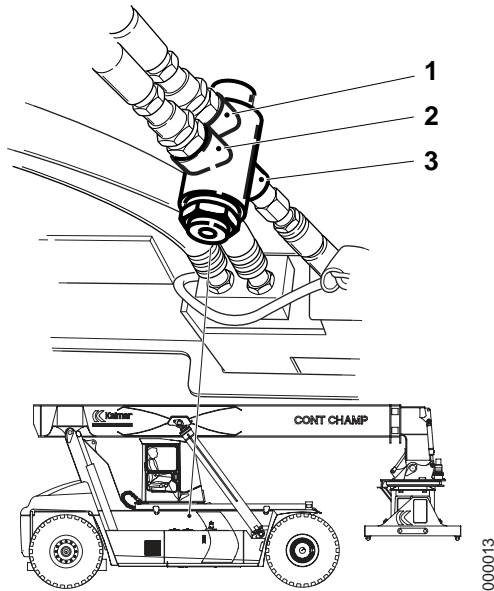

1. Inlet from accumulator [P]
2. Return connection [T]
3. Outlet to brake cylinders [B]

Brake valve, checking

NOTE

Read the safety instructions for oil before working, see section B Safety.

- 1 Operate and warm up the machine so that the brake fluid reaches operating temperature, at least 50 °C.
- 2 Machine in service position, see section *B Safety*.
- 3 Depressurise the brake and hydraulic systems, see section *B Safety*.



- 4 Connect a pressure gauge (0-25 MPa) to the measuring outlet for brake pressure on the distribution block on the front axle.
- 5 Close the drain valve on the accumulator charging valve.
- 6 Start the machine and run it at idling speed until the accumulators are charged and the accumulator charging valve changes to cooling.
- 7 Press down the pedal completely and read off the pressure. Compare to the pressure plate on the left frame member.
- 8 Stop the engine

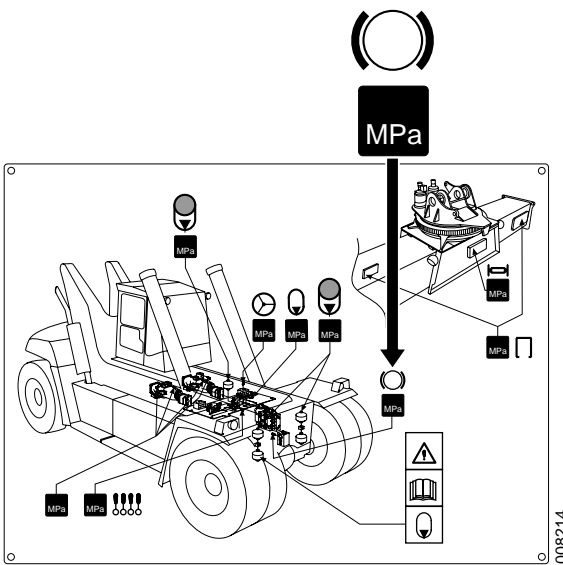

- 9 Depress the pedal fully and keep it pressed down, check the pressure.
The brake pressure must correspond with the value specified on the pressure plate and must not decrease from this value for 15 seconds.

- 10 Release the pedal, the brake pressure must decrease to 0 MPa immediately. Otherwise the brake valve is not sealed and can cause the brakes to remain applied and then overheat during operation.

Replace the brake valve if it is not sealed.

- 11 Depressurise the brake and hydraulic systems, see section *B Safety*.
- 12 Remove the pressure gauge and fit the protective cap on the measuring outlet.

- 13 Close the drain valve on the accumulator charging valve.

NOTE

Check that the accumulator drain valve is fully closed and tighten the lock ring.



Brake valve, replacement

NOTE

Read the safety instructions for oil before working, see section B Safety.

- 1 Slide the cab forward slightly so that the brake valve is accessible under the cab.
- 2 Machine in service position, see section B Safety.
- 3 Depressurise the brake and hydraulic systems, see section B Safety.
- 4 Mark up and detach the hydraulic hoses from the brake valve.



NOTE

Plug the connections immediately to protect the brake system from impurities.

- 5 Secure the brake valve under the cab.



- 6 Remove the brake valve attaching bolt.
- 7 Remove the brake valve.
- 8 Transfer the connection adapters to the new brake valve.
- 9 Install the new brake valve.

NOTE

Remember the spacer ring.

- 10 Connect the hydraulic hoses to the brake valve in accordance with the marking.



NOTE

Check that the O-rings are intact and are fitted correctly.

- 11 Grease and adjust the brake pedal, see *Brake pedal, checking and adjusting* page 3.



- 12 Close the drain valve on the accumulator charging valve.

NOTE

Check that the accumulator drain valve is fully closed and tighten the lock ring.

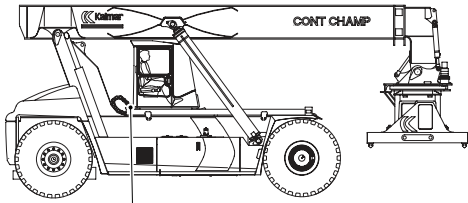

- 13 On machines with manual sliding cab. Secure the cab in the rear-most position with the cab locks.
- 14 Turn on the main electric power and start the engine. Run the engine at idling speed.
- 15 Test the brakes a couple of times.
- 16 Check that the brake valve's connections are sealed tightly.
- 17 Bleed the wheel brakes' brake cylinders, see *Wheel brakes, bleeding* page 29.

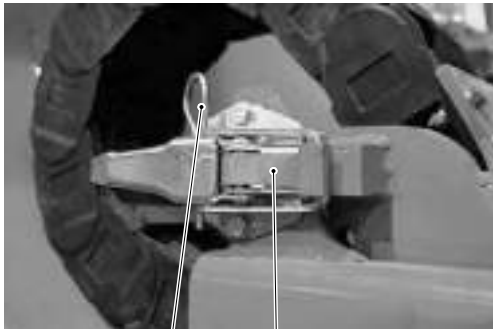

B **C**

000270

- A. Location, lock handle
 B. Lock pin
 C. Lock handle for securing cab

4.3.6 Drive axle block

Drive axle block, description

The drive axle block distributes oil flow and brake pressure to the right and left-hand wheel brakes. The drive axle block is located on a bracket above the drive axle differential.

The drive axle block has a measuring outlet for brake pressure and for measuring back pressure in the disc brake's cooling circuit.

The drive axle block has a bypass valve which guides oil directly from the cooling circuit intake to the cooling circuit return if the resistance in the axle becomes too great. This protects the wheel brake seals, e.g. when the oil is cold.

The drive axle block houses two switches: brake light NO (normally open) switch (S216), see *Switch normally open (NO), brake lights, description page 26*, and declutch NO switch (S220-2), see section 2 *Transmission, group 2.8.2 Normally open (NO) switch, declutch*.

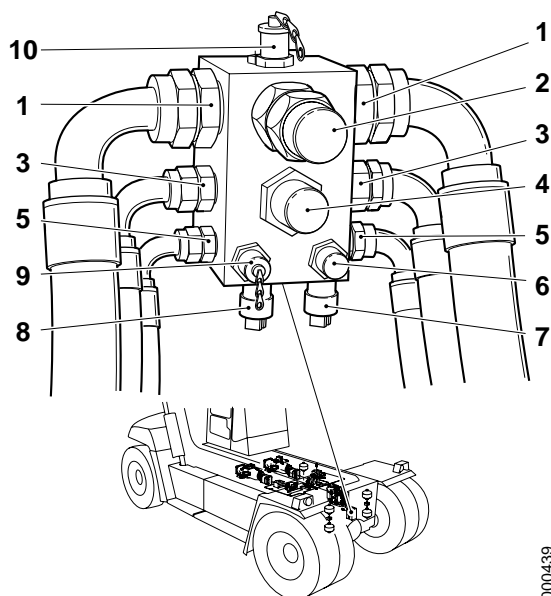

000439

1. Brake cooling connection, return from wheel brake
2. Brake cooling connection, return to cooler
3. Brake cooling connection, to wheel brake
4. Brake cooling connection from accumulator charging valve
5. Brake cylinder connection, to wheel brake
6. Brake pressure connection, from brake valve
7. NO switch, declutch (S220-2)
8. NO switch, brake lights (S216)
9. Measuring outlet, brake pressure
10. Measuring outlet, brake cooling back pressure

4.3.7 NC switch, brake fluid pressure

NC switch, brake oil pressure, description

The brake oil pressure NC switch (S204) detects the pressure in the accumulators. The NC switch is located on the accumulator charging valve on the lifting beam in front of the gearbox in the engine compartment.

When the pressure in the feed circuit is high enough to ensure braking of the machine, the sensor closes an electric circuit. This is used to warn for pressure-drop in the brake system. The sensor's opening pressure is chosen so that there is pressure for another eight brake applications without additional feed from the pump after the light has gone off.

The brake oil pressure NC switch (S204) is supplied voltage by Control unit, frame front (D797-F). When the pressure increases above the cut-off pressure, the voltage signal to Control unit, frame front (D797-F) is cut off.

The signal can be checked from the diagnostic menu, see tab 8 *Control system*, group 8.4.5.4 *HYD, menu 4*.

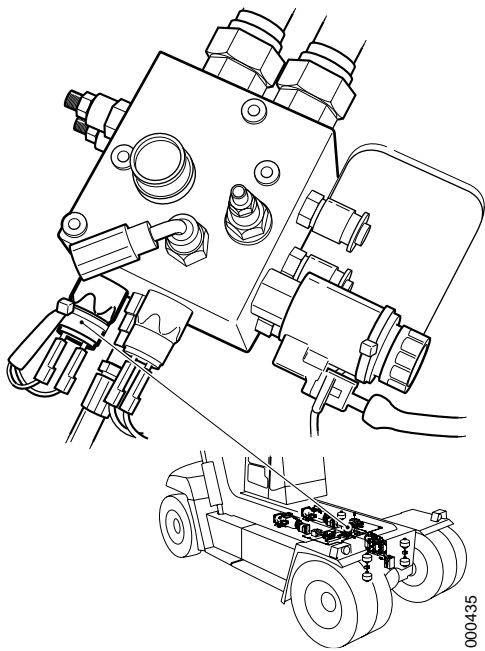

000435

Brake oil pressure NC switch, adjustment

NOTE

Read the safety instructions for oil before working, see section B Safety.

- 1 Operate and warm up the machine until the oil reaches operating temperature, at least 50 °C.
- 2 Machine in service position, see section *B Safety*.
- 3 Depressurise the brake and hydraulic systems, see section *B Safety*.
- 4 Connect a pressure gauge (0-25 MPa) to the measuring outlet for accumulator pressure on the accumulator charging valve.
- 5 Close the drain valve on the accumulator charging valve.
- 6 Start the engine and fully charge the accumulators (the accumulator charging valve changes to cooling).
- 7 Stop the engine and turn the starter key to position I.
- 8 Brake several times, stop when the warning lamp for low brake pressure comes on.
- 9 Read off the accumulator pressure. The pressure should be **approx. 11.5 MPa**.
- 10 If necessary, adjust the warning level by turning the adjusting screw in the rear edge of the sensor, between the contact pins.



NOTE

The setting is very sensitive, turn max. 1/4 turn at a time.

- 11 Repeat steps 6-10 until the warning lamp comes on at 11.5 MPa.
- 12 Seal the adjusting screw with locking fluid.
- 13 Depressurise the brake and hydraulic systems, see section *B Safety*.
- 14 Remove the pressure gauge and fit the protective cap on the measuring outlet.
- 15 Close the drain valve on the accumulator charging valve.

NOTE

Check that the accumulator drain valve is fully closed and tighten the lock ring.



4.3.8 NO (normally open) switch, brake lights

Switch normally open (NO), brake lights, description

The brake light NO switch controls brake light activation when the machine brakes. The switch is located on the drive axle block which sits on a bracket above the drive axle differential.

The brake light NO switch (S216) is supplied voltage by and sends a voltage signal to Control unit, frame front (D797-F). When the pressure increases above the closing pressure, a voltage signal is sent to Control unit, frame front (D797-F).

The signal can be checked from the diagnostic menu, see tab 8 *Control system*, group 8.4.5.4 *HYD*, menu 4.

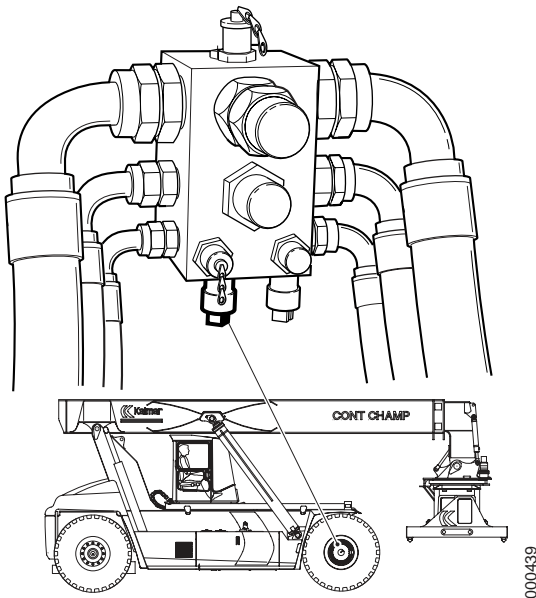

Brake light NO switch, checking

NOTE

Read the safety instructions for oil before working, see section B Safety.

- 1 Operate and warm up the machine until the brake fluid reaches operating temperature, at least 50 °C.
- 2 Stop the engine and turn the starter key to position I.
- 3 Brake and check that the brake light comes on.

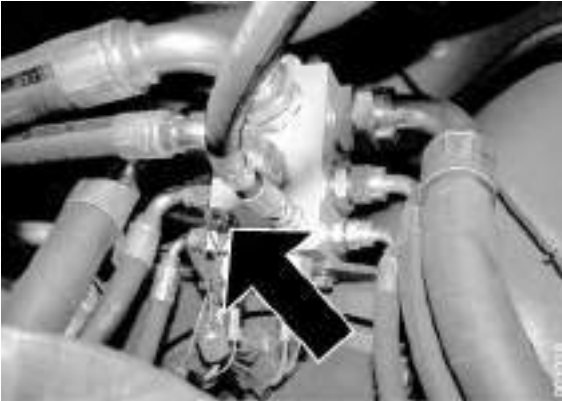

DIAG HYD	4 (6)
PRESSURE SWITCHES	
BRAKE PRESSURE	X
BRAKE LIGHT PRESS.	X
DECLUTCH PRESSURE	X

000144

- 4 Depressurise the brake and hydraulic systems, see section *B Safety*.
- 5 Connect a pressure gauge (0-25 MPa) to the measuring outlet for brake pressure on the distribution block.
- 6 Close the drain valve on the accumulator charging valve.
- 7 Start the engine.

- 8 Use the display, go to the diagnostic menu, see section *8 Control system*, group *8.4.5.4 HYD, menu 4*.

BRAKE LIGHT PRESS. indicates status for the brake light contact. 1 = Activated contact (brakes applied).

- 9 Press down the brake pedal slowly until the brake light is activated or the status of the input signal changes. Keep the pedal in this position and check the pressure on the pressure gauge.

The status can be changed and the brake light should come on when the pressure is **approx. 0.2 MPa**.

- 10 Stop the engine
- 11 Depressurise the brake and hydraulic systems, see section *B Safety*.
- 12 Remove the pressure gauge and fit the protective cap on the measuring outlet.
- 13 Close the drain valve on the accumulator charging valve.

NOTE

Check that the accumulator drain valve is fully closed and tighten the lock ring.



4.3.9 Wheel brake

Wheel brake, description

The wheel brakes brake the machine during operation and are located on the drive axle between the drive axle housing and hub reduction.

The wheel brake uses so-called wet disc brakes (WDB). Wet disc brakes require minimal maintenance and have a long service life due to effective cooling. Maintenance requirements are minimised since oil circulates in the brake system and prevents corrosion.

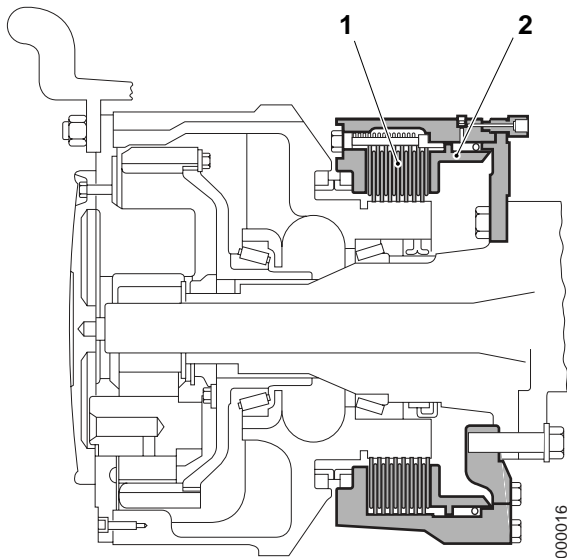
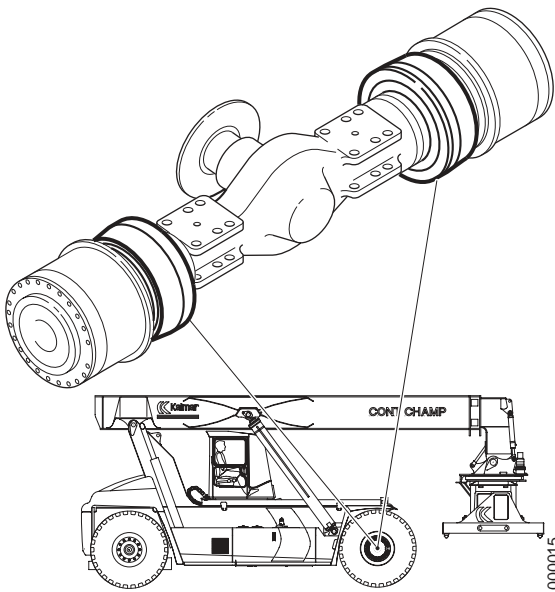

Wheel hub and brake, cross-section

1. Disc assembly
2. Brake cylinder

The wheel brakes have two main sections - disc assembly and brake cylinder. The disc assembly performs the braking. The brake cylinder presses the discs in the disc assembly together during braking.

Wheel brakes, bleeding

NOTE

Read the safety instructions for oil before working, see section B Safety.

IMPORTANT

Both the brake cylinder and disc brake must be bled after work where the brake system is opened or after work on the wheel brake.

Brake cylinder



Bleed nipple, brake cylinder, on top of the drive axle at the wheel hub's inner short side (left-hand side).

- 1 Machine in service position, see section B Safety.
- 2 Place a ring spanner on the bleed nipple and connect a transparent hose to the bleed nipple.
Lead the other end of the hose down into a collection container.
- 3 Start the machine and depress the brake pedal, keep the pedal depressed.
- 4 Open the bleed nipple and allow oil to run out of it until the oil is free of air bubbles.

NOTE

The hydraulic hose between the brake pedal and brake is approx. 7 metres long. Therefore, allow at least two litres of oil to pass through the air bleeder nipple when bleeding to ensure that no air pockets remain in the system.

- 5 Close the bleed nipple.
- 6 Move the spanner and hose and repeat steps 1–4 on the other side.

Disc brake

NOTE

Disc brake ventilation is vital to correct cooling of the discs.

- 1 Start the engine and allow it to idle. Wait until the brake accumulators are fully loaded and the accumulating charging valve has switched to brake cooling.
- 2 Remove the bleed screw of the disc brake and let oil flow out of the hole until it is free of air bubbles. Refit the bleed screw.
- 3 Repeat steps 1-3 on the other wheel.
- 4 Check the oil level in the brake system, fill as necessary.

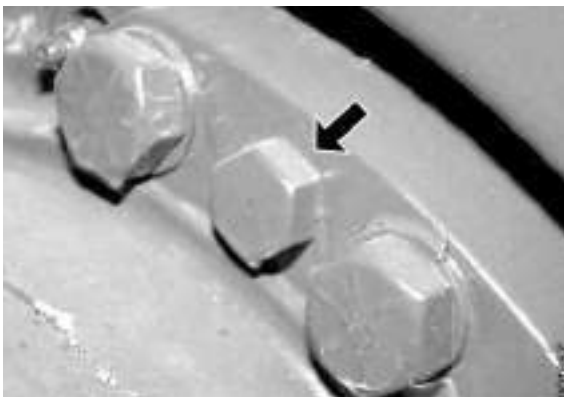

Bleed nipple, disc brake, on top of the drive axle at the wheel hub's inner short side (left-hand side).

Wheel brake, replacement

See *supplier documentation, drive axle*.

4.3.9.1 Disc assembly

Disc assembly, description

The disc assembly consists of several thin metal discs fixed alternately to the wheel brake housing and to the hub reduction housing. The discs are mounted on splines, which allows them to move laterally.

Oil circulates between the discs cooling them, thus the name wet disc brake. The oil is the same as in other parts of the brake system.

Braking is effected by the brake cylinder pressing together the discs. This creates friction between the discs that are fixed to the axle and those fixed to the hub reduction.

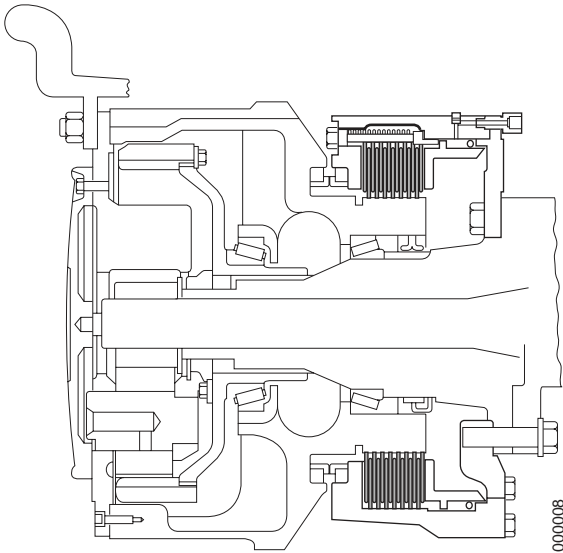

Disc assembly

4.3.9.2 Brake cylinder

Brake cylinder, description

The brake cylinder is integrated in the wheel brake and consists of a metal ring (cylinder) with two seal rings. The seals have lateral support from a bevel on the cylinder and a bevel on the wheel brake housing.

The space between the seal rings is pressurised through a channel in the wheel brake housing. The pressure moves the metal ring sideways and compresses the disc assembly.

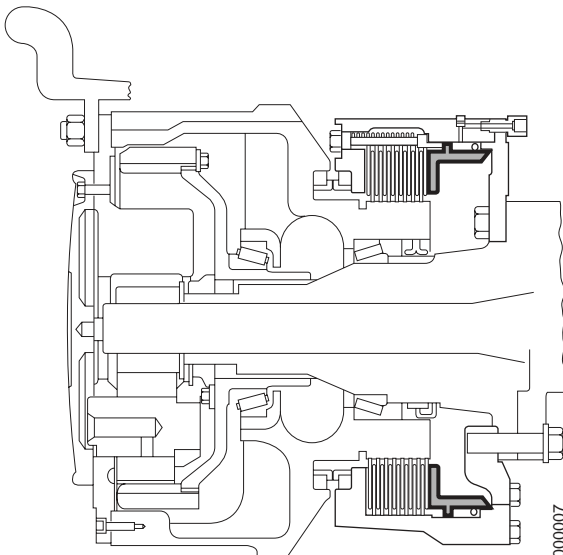

Brake cylinder

4.3.10 Pipes and hoses

Piped and hoses, description

See section *10 Common hydraulics*, group *10.5.1 Pipes and hoses*.

4.5 Parking brake system

Parking brake system, function description

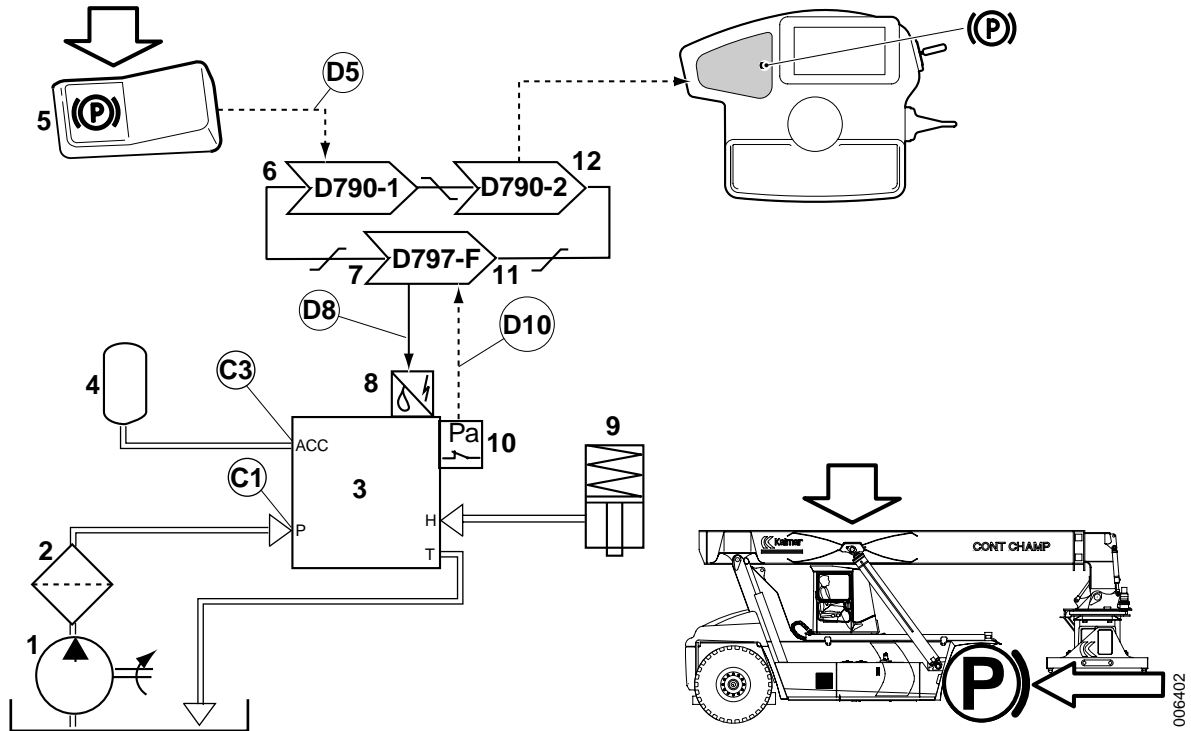

Pos	Explanation	Signal description	Reference
1	The brake fluid pump pumps fluid from the brake fluid tank.	P = 19 ±0.5 MPa	Brake fluid tank, description page 39 Brake fluid pump, description page 7
2	The brake fluid filter cleans dirt from the oil.	-	Brake fluid filter, description page 45
3	The accumulator charging valve directs oil to charging of accumulators or through the brake system's cooling circuit.		Accumulator charging valve, description page 13
4	The accumulators store oil pressure.	See pressure plate on left frame beam.	Accumulator, description page 16
5	Switch parking brake (S107) activates parking brake. The switch uses two signals - one for applied and one for released parking brake. Both signals must be correct to enable release of the parking brake.	Switch activated: Conn 1, U = 22–28 V Conn 7, U = 0 V Switch in home position: Conn 1, U = 0 V Conn 7, U = 22–28 V	Section 9 Frame, body, cab and accessories, group 9.1 Controls and instruments D5: Diagnostic menu, see section 8 Control system, group 8.4.5.5 HYD, menu 5
6	The cab control unit (D790-1) transmits release or apply parking brake on the CAN bus.	Checked by control system, error shown with error code.	Section 11 Common electrics, group 11.5.3.1 Cab control unit

Pos	Explanation	Signal description	Reference
7	Control unit, frame front (D797-F) activates the parking brake solenoid valve (Y642).	U = 24 V	Section 11 <i>Common electrics</i> , group 11.5.3.2 <i>Control unit, frame front</i> D8: Diagnostic menu, see section 8 <i>Control system</i> , group 8.4.5.5 <i>HYD</i> , menu 5
8	Solenoid valve parking brake (Y642) affects the valve slide which drains pressure in the parking brake calliper to tank.	Pump pressure.	<i>Solenoid valve parking brake, description page 33</i> D8: Diagnostic menu, see section 8 <i>Control system</i> , group 8.4.5.5 <i>HYD</i> , menu 5
9	The brake calliper is drained of pressure and the spring applies the parking brake.	0 MPa	<i>Parking brake unit, description page 34</i>
10	The parking brake NC switch (S200) closes the circuit when the pressure decreases.	Applied parking brake: Conn 1: U = 24 V Conn 2: U = 0 V Released parking brake: Conn 1: U = 24 V Conn 2: U = 24 V	<i>Parking brake NC switch, description page 37</i> D10: Diagnostic menu, see section 8 <i>Control system</i> , group 8.4.5.5 <i>HYD</i> , menu 5
11	Control unit, frame front (D797-F) transmits parking brake applied on the CAN bus.	Checked by control system, error shown with error code.	Section 11 <i>Common electrics</i> , group 11.5.3.2 <i>Control unit, frame front</i>
12	The KIT control unit (D790-2) activates the parking brake indicator light (508).	Checked by control system, error shown with error code.	Section 11 <i>Common electrics</i> , group 11.5.3.11 <i>Control unit KIT</i>

Hydraulic diagram, basic machine

4.5.1 Brake fluid pump

Brake fluid pump, general

See group 4.3.1 *Brake fluid pump*.

4.5.2 Brake fluid filter

Brake fluid filter, general

See *Brake fluid filter, description page 45*.

4.5.3 M-valve parking brake

Solenoid valve parking brake, description

The parking brake solenoid valve (Y642) activates the parking brake. The solenoid valve is fitted on the accumulator charging valve, which is fitted on the lifting beam in front of the gearbox in the engine compartment, see *Accumulator charging valve, description page 13*.

The solenoid valve opens a connection between the accumulators and the parking brake calliper at activation. This means that the parking brake calliper is pressurised and the parking brake is disengaged. When the voltage feed to the solenoid valve is cut off, the connection between the accumulators and parking brake calliper is terminated. Instead, a connection between the parking brake calliper and tank is opened and the parking brake applied. This means that the parking brake is applied if the machine loses electrical power or if the brake system becomes depressurised.

The solenoid valve is supplied with voltage by Control unit, frame front (D797-F) on activation.

The signal can be checked from the diagnostic menu, see section *8 Control system*, group *8.4.5.5 HYD, menu 5*.

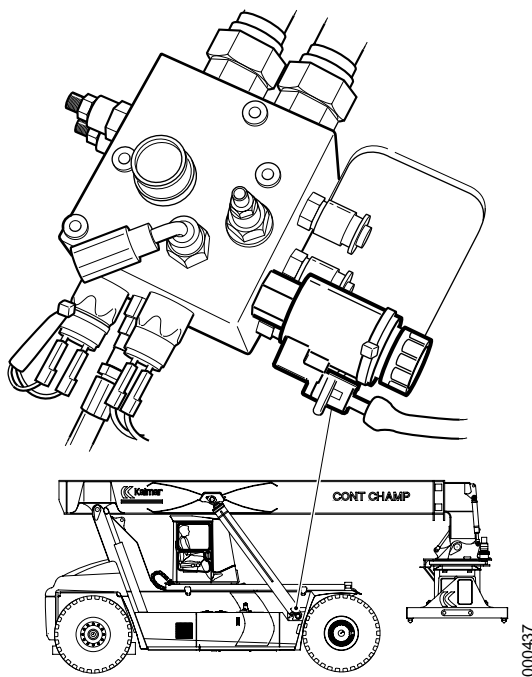

Solenoid valve parking brake, checking



DANGER

The machine may start to roll. Risk of crushing.

Block the wheels so that the machine cannot start to roll when the parking brake is released.

- 1 Start the engine and run the engine at idling speed until the warning lamp for brake pressure goes out and the accumulator charging valve changes to cooling.
- 2 Turn off the engine and turn the start key to position I.
- 3 Release the parking brake with switch parking brake and check that the parking brake's brake caliper releases. The brake caliper should be able to move.
- 4 Activate the parking brake with the parking brake switch and check that the parking brake's brake caliper is applied.

4.5.4 Parking brake unit

Parking brake unit, description

The parking brake unit keeps the machine stationary when parked. The parking brake unit is located on the drive axle input shaft between the propeller shaft and drive axle.

The parking brake acts on the propeller shaft via a disc mounted on the drive axle input shaft and a brake calliper with dry brake pads mounted in a bracket on the drive axle.

NOTE

If the hydraulic pressure in the feed circuit drops, a warning is activated before the pressure drops so low that the parking brake is applied. If the parking brake is applied while the machine is in motion, the brake disc and brake pads must be replaced.

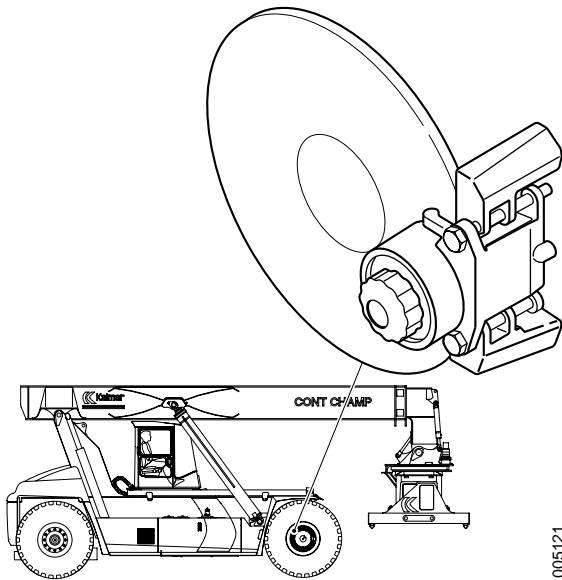

005121

Parking brake unit, checking and adjustment (drive axle alternative Kessler)

DANGER

The machine may start to roll.

Risk of crushing.

Block the wheels so that the machine cannot start to roll when the parking brake is released.

- 1 Start the engine and run up hydraulic pressure until the accumulators are fully charged and the accumulator charging valve switches to cooling.
- 2 Turn off the engine and turn the start key to position I.
- 3 Release the parking brake.
- 4 Check that the parking brake caliper can move on the bracket.
- 5 Check that the brake disc is free from oil and dirt.



6 Remove the cover from the brake caliper.



7 Undo the lock nut.

8 Adjust the adjustment screw so that the brakes are applied.

9 Turn back the adjusting screw so that the clearance between pad and disc is 0.5 ± 0.1 mm.

10 Tighten lock nut.

NOTE

To avoid turning the adjustment screw as well it must be held still when tightening the lock nut.

11 Refit the cover to the caliper.

12 Test the operation of the parking brake.

4.5.4.1 Parking brake caliper

Brake calliper, description

The brake calliper has a spring section and a hydraulic section. The spring section applies the brake while the hydraulic section is used to release the brake. This means that the parking brake is applied if the brake system loses pressure. This, in turn, means that the machine is braked if a serious fault arises.

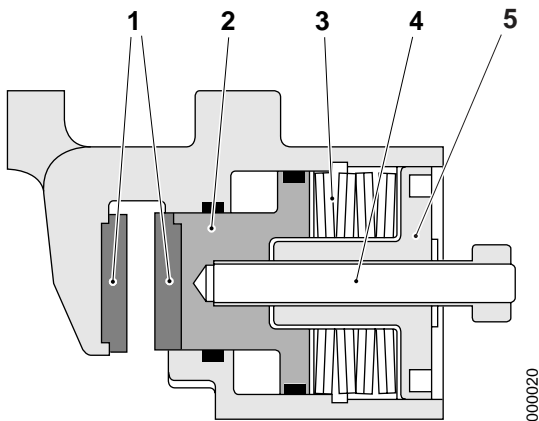

000020

1. Brake pads
2. Release cylinder
3. Return spring
4. Slackening screw
5. Adjusting washer

4.5.4.2 Parking brake pads

Brake pads, description

The brake pads consist of a metal plate with friction material (lining).

Brake pads, replacement

DANGER

The machine may start to roll.

Risk of crushing.

Block the wheels so that the machine cannot start to roll when the parking brake is released.

- 1 Machine in service position and wheels blocked, see section *B Safety*.
- 2 Remove the cover from the brake caliper.



- 3 Undo the lock nut.
- 4 Slacken the adjusting screw to release the brake pads.
- 5 Remove the split pin and undo the nut on one of the attaching bolts holding the parking brake calliper in place.





- 6 Pull the attaching bolt out so that the brake pads can be angled out and removed.

NOTE

The bolt does not need to be removed.

- 7 Remove the parking brake pads.
- 8 Clean the brake disc with methylated spirit.
- 9 Install new parking brake pads.
- 10 Press the attaching bolt back.
- 11 Fit the nut and a new split pin.
- 12 Adjust the parking brake, see *Parking brake unit, checking and adjustment (drive axle alternative Kessler) page 34.*

4.5.4.3 Parking brake disc

Brake disc, description

The brake disc is mounted on the drive axle input shaft. The drive axle's gear ratio amplifies the braking force.

4.5.5 Parking brake NC switch

Parking brake NC switch, description

The parking brake NC switch (S200) detects whether the parking brake is applied or released. The NC switch is fitted on the accumulator charging valve, which is fitted on the lifting beam in front of the gearbox in the engine compartment, see *Accumulator charging valve, description page 13.*

Break-contact parking brake (S200) senses the pressure in the parking brake circuit. When the pressure is so high that the parking brake is released, the sensor opens an electric circuit. This is used to indicate that the parking brake is released.

The parking brake NC switch (S200) is supplied voltage by, and sends a voltage signal to, Control unit, frame front (D797-F). When the pressure increases above the cut-off pressure, the voltage signal to Control unit, frame front (D797-F) is cut off.

The signal can be checked from the diagnostic menu, see section *8 Control system*, group *8.4.5.5 HYD, menu 5.*

NOTE

Gears cannot be engaged when the parking brake is applied.

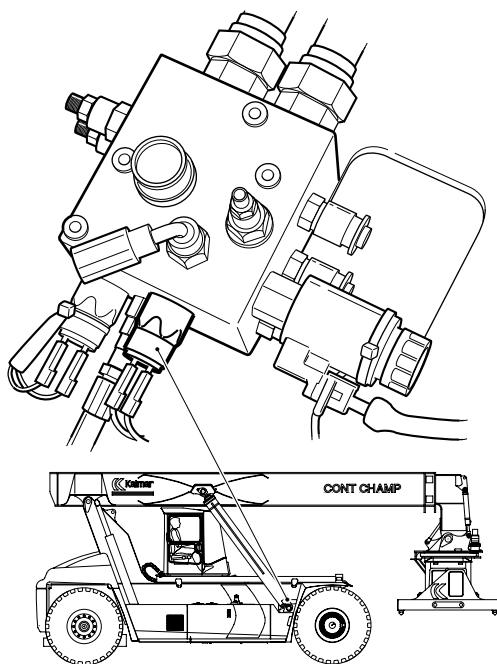

000436

4.5.6 Pipes and hoses

Piped and hoses, description

See section *10 Common hydraulics*, group *10.5.1 Pipes and hoses.*

4.8 Temperature control, cleaning and brake oil

Temperature control, cleaning and brake oil, function description

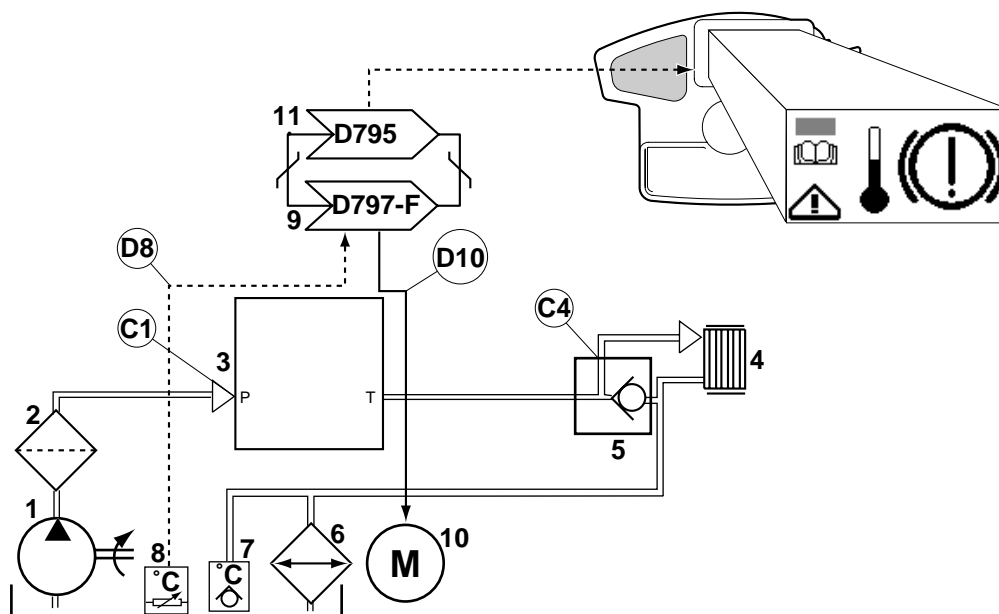

006403

Pos	Explanation	Signal description	Reference
1	The brake fluid pump pumps fluid from the brake fluid tank.	$P = 19 \pm 0.5 \text{ MPa}$	<i>Brake fluid pump, description page 7</i> <i>Brake fluid tank, description page 39</i>
2	The brake oil filter cleans the oil.	-	<i>Brake fluid filter, description page 45</i>
3	The accumulator charging valve directs oil to charging of accumulators or through the brake system's cooling circuit.	Max. 0.1 MPa	<i>Accumulator charging valve, description page 13</i>
4	The oil cools the wheel brake.	-	<i>Wheel brake, description page 28</i>
5	The bypass valve in the distribution block leads oil past the drive axle if the back pressure through the wheel brake is too high.	-	<i>Drive axle block, description page 24</i>
6	The cooler cools the oil.	-	<i>Oil cooler, description page 41</i>
7	The thermo-bypass valve leads oil past the cooler if the temperature is low.	approx. 50 °C	<i>Thermal bypass valve, description page 42</i>
8	The temperature sensor (B762) detects and oil temperature and sends Control unit, frame front (D797-F) a voltage signal proportional to the oil temperature.	$R = 25 \text{ k}\Omega \text{ at } 20 \text{ }^\circ\text{C}$	<i>Brake fluid temperature sensor, description page 43</i> D8: Diagnostic menu, see section 8 Control system , group 8.4.5.2 HYD, menu 2

Pos	Explanation	Signal description	Reference
9	Control unit, frame front (D797-F) transmits the oil temperature information on the CAN bus.	Checked by control system, error shown with error code.	Section 11 <i>Common electrics</i> , group 11.5.3.2 <i>Control unit, frame front</i>
10	When the oil is hot, Control unit, frame front (D797-F) activates the cooling fan (M674) and increases airflow through the cooler.	U = 24 V with activated fan Activates at 65 °C Deactivates at 55 °C	<i>Cooling fan, description page 42</i> D10: Diagnostic menu, see section 8 <i>Control system</i> , group 8.4.5.2 <i>HYD, menu 2</i>
11	If temperature is high, the KID control unit (D795) activates the high brake fluid temperature warning in the display.	Checked by control system, error shown with error code.	Section 11 <i>Common electrics</i> , group 11.5.3.12 <i>KID control unit</i>

Hydraulic diagram, basic machine

4.8.1 Brake fluid tank

Brake fluid tank, description

The brake fluid tank stores the brake system fluid and is located on the left side of the machine in front of the fuel tank.

The brake system is separate from other hydraulics and has its own tank and oil filter. This makes it possible to keep additives out of the brake system fluid.

Brake fluid is filled directly to the tank. A drain plug is located at the bottom of the tank. Hatches on top of the tank facilitate internal cleaning.

The tank is equipped with a filtered breather that allows volume changes in the tank, due to temperature variations and use. See *Breather filter, description page 44*.

The tank has a sight glass for checking oil level.

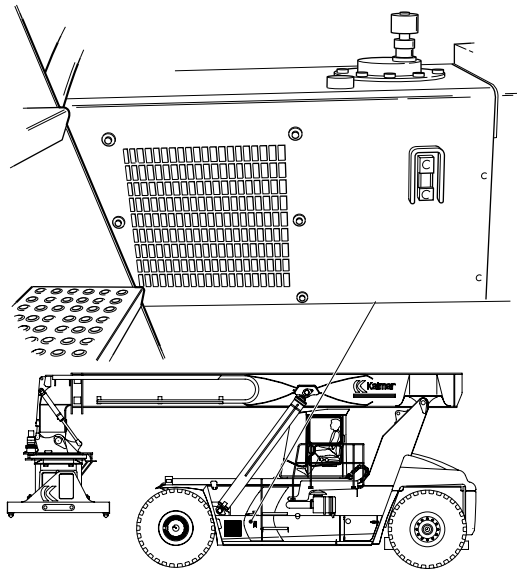

4.8.2 Tank heater

Tank heater, safety



CAUTION

High voltage.

The tank heater is connected to high voltage (110 - 400 V).

Installation and reconnection of the tank heater may only be performed by personnel authorised for work with high voltage.

Tank heater, description



The brake fluid tank can be equipped with a tank heater, which heats the brake fluid in the tank and sits in a flange on the front short side of the tank. The tank heater is designed for cold-climate usage.

The tank heater is operated with high voltage. Heater output is adapted through different connections and adaptation to different operating voltage - 110, 230 or 400 V AC. Higher voltage generates higher heater output.

The tank heater can be equipped with an adjustable thermostat which maintains a constant temperature level. The thermostat is mounted directly on the heating coil and can be adjusted using the control on the terminal box. The recommended temperature setting is 20 –30 °C.

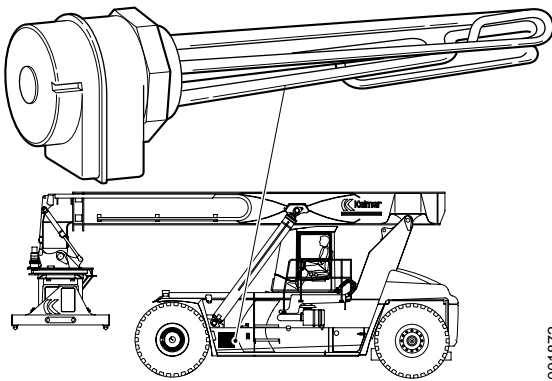

001872

4.8.3 Brake fluid pump

Brake fluid pump, general

See group 4.3.1 *Brake fluid pump*.

4.8.4 Accumulator charging valve

Accumulator charging valve, general

See 4.3.3 *Accumulator charging valve*.

4.8.5 Drive axle block

Drive axle block, description

See *Drive axle block, description page 24*.

4.8.6 Wheel brake

Wheel brake, general

See 4.3.9 *Wheel brake* and *drive axle supplier documentation*.

4.8.7 Oil cooler

Oil cooler, description

The oil cooler cools the brake system fluid in order to maintain brake performance. The oil cooler is found inside the side panel on the left side behind the front wing.

The brake system uses a flow-through cooler with electric cooling fan. The brake system fluid is cooled when it passes the cooler. Openings in the frame panel allow air to pass through the cooler.

The cooling fan is screwed onto the cooler. See *Cooling fan, description page 42*.

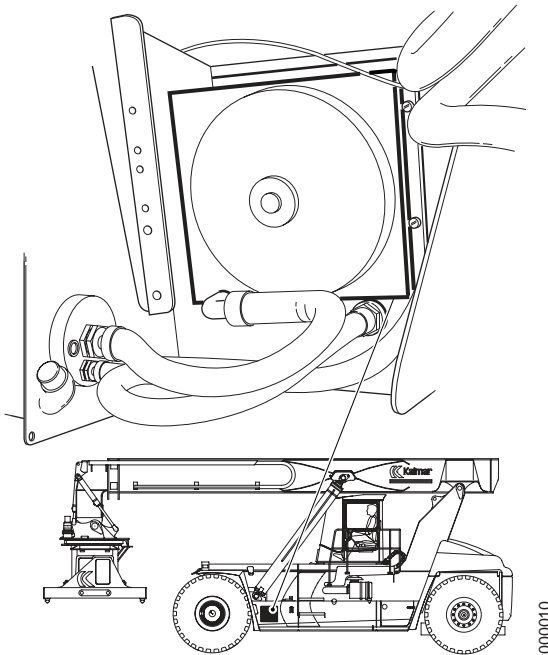

Brake system oil cooler, replacement

NOTE

Read the safety instructions for oil before working, see section B Safety.

- 1 Machine in service position, see section B Safety.
- 2 Drain the brake fluid tank; see *Brake system fluid, changing page 46*.
- 3 Mark up and disconnect hydraulic hoses from the cooler. Let the oil in the cooler drain into the collection container.

NOTE

Plug all unions at once to protect the hydraulic system from contamination.

- 4 Disconnect the cabling from the cooling fan.
- 5 Remove the attaching bolts and lift away the cooler.
- 6 Transfer the cooling fan to the new cooler.
- 7 Install the cooler.
- 8 Connect the cabling to the cooling fan.
- 9 Connect the hydraulic hoses to the cooler.

NOTE

Check that the O-rings are intact and fitted correctly.

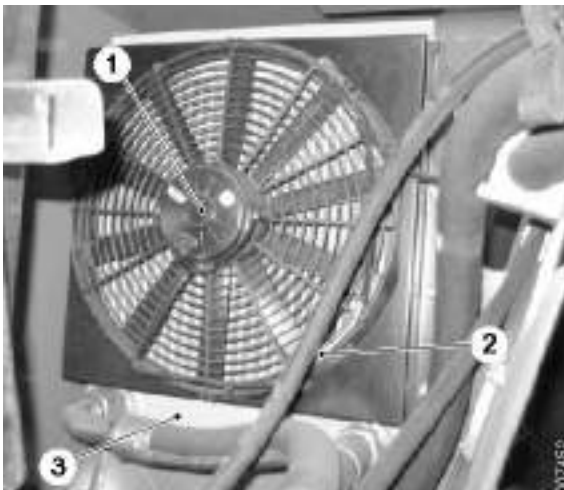

1. Cooling fan
2. Connector
3. Radiator



- 10 Fill the brake fluid tank; see *Brake system fluid, changing page 46*. The fluid level should be visible in the sight glass.

4.8.8 Cooling fan

Cooling fan, description

The cooling fan (M674) is a suctioning electronic fan. The fan suctions air from the outside of the machine through the cooler and increases airflow through the oil cooler as needed. The cooling fan is mounted inside the cooler inside the side panel behind the left drive wheel.

The cooling fan (M674) is supplied voltage by Control unit, frame front (D797-F). The cooling fan is activated when oil temperature is 65 °C in the brake oil tank and the fan is deactivated when oil temperature is 55 °C.

The signal can be checked from the diagnostic menu, see section *8 Control system*, group *8.4.5.2 HYD, menu 2*.

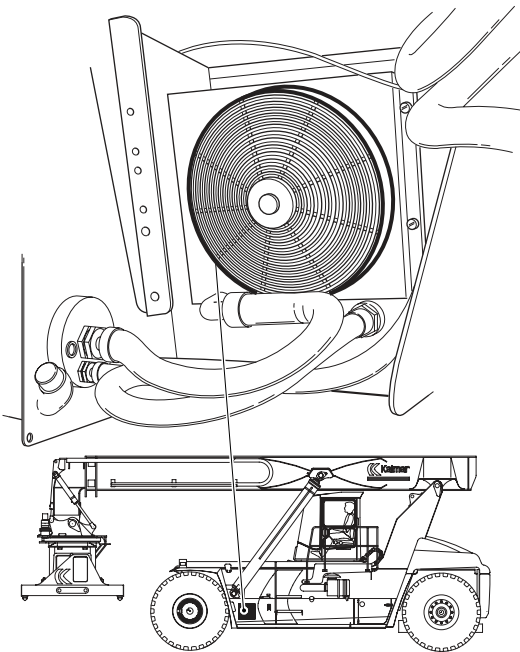

000009

4.8.9 Thermal bypass valve

Thermal bypass valve, description

When the oil is cold, the thermo-bypass valve guides the oil past the cooler directly to the tank. The thermo-bypass valve is found inside the brake fluid tank at the hose connections to and from the cooler.

The thermo-bypass valve is a temperature-regulated bimetal valve that is open at low temperatures and completely closed at 50 °C.

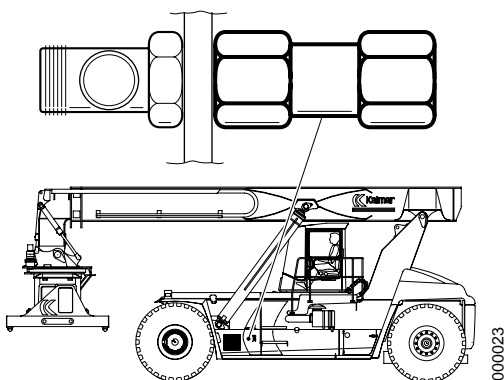

000023

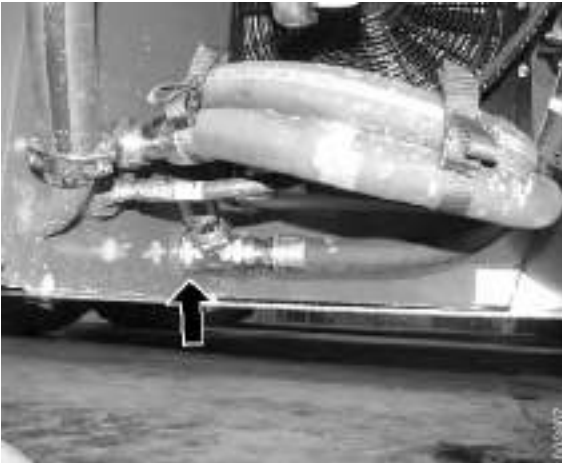

Thermo-bypass valve, replacement

NOTE

Read the safety instructions for oil before working, see section B Safety.

- 1 Machine in service position, see section *B Safety*.
- 2 Depressurise the brake and hydraulic systems, see section *B Safety*.
- 3 Drain the brake fluid tank; see *Brake system fluid, changing page 46*.
- 4 Remove the thermo-bypass valve located inside the hydraulic oil tank.

NOTE

Note how the valve is fitted.

- 5 Fit in reverse order.

4.8.10 Sensor brake oil temperature

Brake fluid temperature sensor, description

The brake fluid temperature sensor (B762) detects the temperature of the brake system fluid. The sensor is mounted on the rear short side of the brake fluid tank and therefore takes the accumulated heat in the brake system fluid into account.

The brake fluid temperature sensor (B762) is supplied voltage by Control unit, frame front (D797-F) and sends the control unit a voltage signal proportional to temperature.

The signal can be checked from the diagnostic menu, see section *8 Control system*, group *8.4.5.2 HYD, menu 2*.

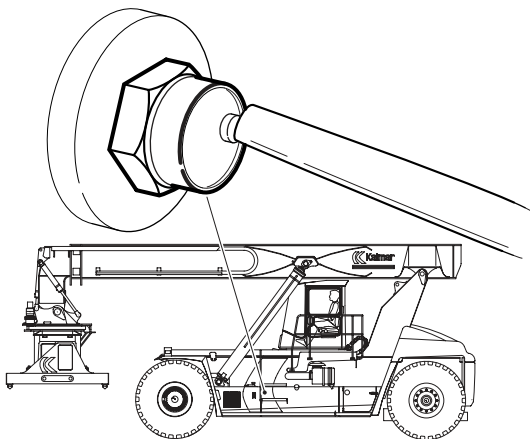

001091

Brake fluid temperature sensor, replacement

NOTE

Read the safety instructions for oil before working, see section B Safety.

- 1 Machine in service position, see section *B Safety*.
- 2 Drain the brake fluid tank; see *Brake system fluid, changing page 46*.
- 3 Disconnect the wiring from the fluid temperature sensor.
- 4 Remove the fluid temperature sensor.

NOTE

Check that the O-rings are intact and fitted correctly.

- 5 Connect the cabling to the sensor.



- 6 Fill the brake fluid tank; see *Brake system fluid, changing page 46*. The fluid level should be visible in the sight glass.

4.8.11 Breather filter

Breather filter, description

The breather filter cleans the air that passes the tank's breather upon volume changes arising due to temperature variations and use. The breather filter is located in a holder on the top of the brake fluid tank.

The breather filter is a paper insert filter. The filter removes moisture and dust from the air passing through the tank's breather.

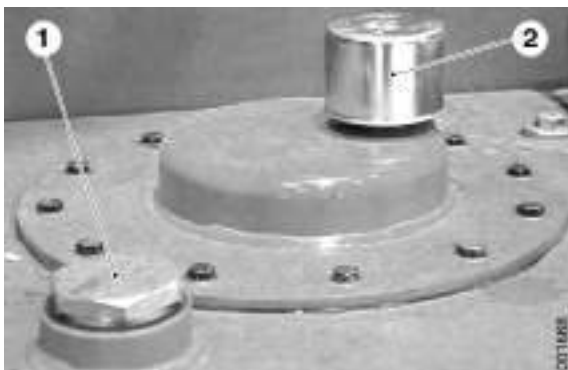
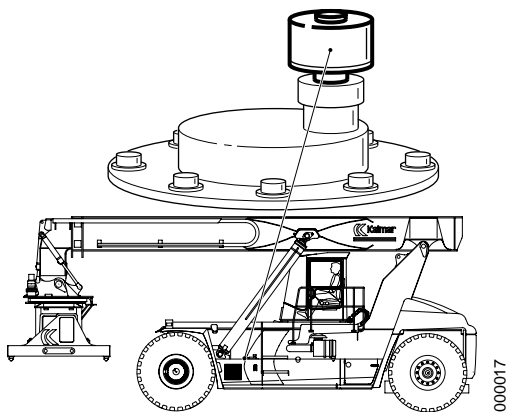

1. Brake system fluid filler orifice
2. Breather filter, brake fluid tank

Breather filter, replacement

- 1 Clean the area around the break tank breather filter.
- 2 Remove the cover from the filter holder.
Remove the centre screw and lift away the cover.
- 3 Remove the old filter insert.
- 4 Clean the filter holder.

NOTE

Take care so as not to contaminate the tank.

- 5 Fit a new filter insert.
- 6 Refit the cover on the filter holder.

4.8.12 Brake fluid filter

Brake fluid filter, description

The brake fluid filter eliminates contaminants from the fluid in the brake system. The filter is secured on a mounting in front of the gearbox under the lifting beam.

The brake system fluid filter is a high-pressure filter with removable filter insert. It is located between the pump and accumulator charging valve. The fluid is cleaned when it is forced through the (glass-fibre) material of the filter insert before reaching the accumulator charging valve.

A bypass valve located between the intake and outlet protects the insert. If resistance through the filter surface becomes too great, the bypass valve opens a passage past the insert. The bypass function opens if the oil is viscous (cold or too low/high viscosity) or if the filter insert is clogged with dirt.

NOTE

When the filter is clogged, the oil is directed past the filter without cleaning. Therefore, it is very important to replace the filter at the prescribed interval.

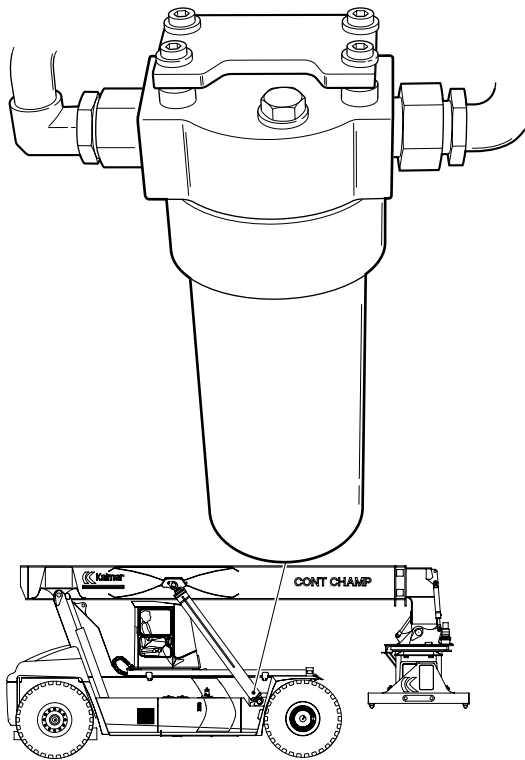

000018

Brake fluid filter, replacement

NOTE

Read the safety instructions for oil before working, see section B Safety.

IMPORTANT

The filter protects the brake system against contaminants. It is vital that new contaminants do not enter the brake system during filter replacement.

- 1 Machine in service position, see section *B Safety*.
- 2 Depressurise the hydraulic and brake systems; see section *B Safety*.

NOTE

Leave the valves open during replacement.

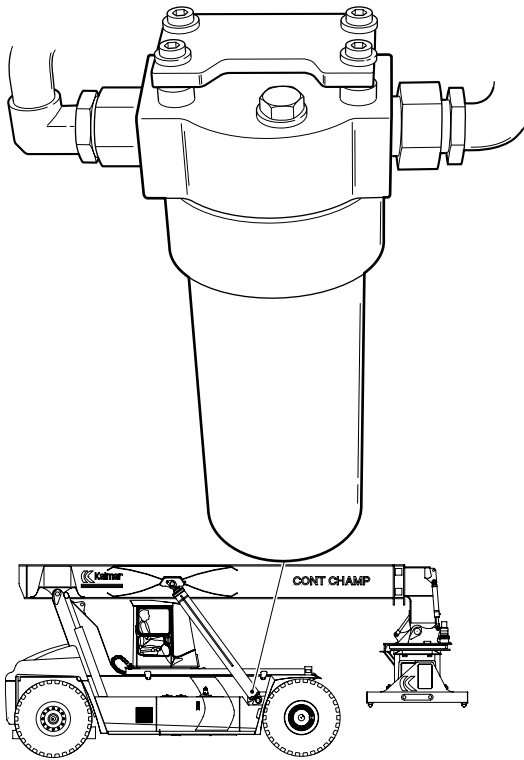

000018

- 3 Remove the drain plug on the underside of the filter.
Let the oil run out. Wait a moment since it runs out slowly.
- 4 Remove the filter holder.

NOTE

The filter holder is heavy. Detach it carefully.

- 5 Remove the filter insert.

NOTE

Note the location of the O-rings.

- 6 Clean the filter holder.
- 7 Fit the O-rings on the filter insert and filter holder. Lubricate the O-rings with brake fluid.
- 8 Fit the new filter insert on the filter mounting.
- 9 Fit the filter holder and drain plug.
- 10 Close the valves opened for draining the pressure in the hydraulic system.
- 11 Start the engine and check the filter holder for leaks.

4.8.13 Pipes and hoses

Piped and hoses, description

See section *10 Common hydraulics*, group *10.5.1 Pipes and hoses*.

4.8.14 Brake system fluid

Brake system fluid, general

See section *F Technical data*.

Brake system fluid, changing

NOTE

Read the safety instructions for oil before working, see section B Safety.

- 1 Machine in service position, see section *B Safety*.
- 2 Depressurise the hydraulic and brake systems; see section *B Safety*.
- 3 Remove the filler cap and drain the brake fluid tank.
- 4 Remove the drain plug and allow the last of the fluid drain into a receptacle.
- 5 Fit the drain plug, using a new gland washer.
- 6 Fill brake fluid until the fluid level is in the middle of the sight glass. For volume and grade, see section *F Technical data*.
- 7 Fit the filler cap.

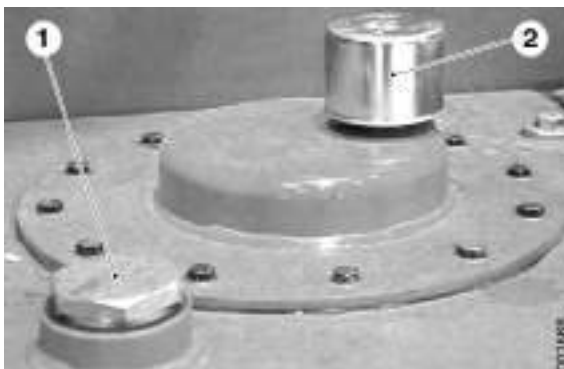

1. Brake system fluid filler orifice
2. Breather filter, brake fluid tank

Table of Contents 5 Steering

5	Steering	3
5.1	Controls and instruments	3
5.1.2	Mini-wheel	3
5.1.3	Joystick	4
5.2	Power assisted system	6
5.2.1	Hydraulic oil pump	13
5.2.2	Priority valve	14
5.2.3	Steering valve	20
5.2.4	Steering cylinder	23
5.2.5	Steering axle cradle	26
5.2.6	Link arm	27
5.2.7	Wheel spindle	27
5.2.8	Wheel hub	27
5.2.9	Shuttle valve	27
5.2.10	Control valve mini-wheel/joystick control	28
5.2.11	Shuttle valve, mini-wheel/lever steering	31
5.2.12	Steering angle sensor	32
5.2.13	Pipes and hoses	32

5 Steering

5.1 Controls and instruments

5.1.2 Mini-wheel

Mini-wheel, description



On machines with mini-wheel, the machine is steered with an electric control. A directional valve pressurises the steering cylinder.

The mini-wheel controls are integrated in the left armrest. The controls consist of two rotary potentiometers and three switches to activate the mini-wheel, select direction of travel and activate the horn.

NOTE

The mini-wheel is deactivated if the standard steering wheel is used.

Mini-wheel or lever steering can only be activated at speeds below 3 km/h.

Mini-wheel

Rotary potentiometers transmit a 0-5 V signal for one revolution. The potentiometers have phase displacement to determine the direction of turning. The rotary potentiometers are supplied voltage by the cab control unit (D790-1) and send it a voltage signal proportional to the turn to indicate steering deflection.

The relationship between the deflection of the mini-wheel and that of the wheels can be set to 31 different settings - from linear to extremely progressive. It is also possible to set how steering deflection is to be adapted based on machine speed. This is done via the diagnostic menus; see section *8 Control system*, group *8.5.1 Initiation*.

The signals can be read from the diagnostic menu, see section *8 Control system*, group *8.4.11.4 EL-STEERING*, menu 1.

Switch, mini-wheel activation

The mini-wheel switch (position 3) activates steering with the mini-wheel. The switch is supplied voltage by and sends a voltage signal to the cab control unit (D790-1).

The signals can be read from the diagnostic menu, see section *8 Control system*, group *8.4.11.4 EL-STEERING*, menu 2.

Travel direction selector

The travel direction selector is used to choose direction of travel (forward or reverse) when the mini-wheel is activated. The switch is supplied voltage by and sends a voltage signal to the cab control unit (D790-1).

The signals can be read from the diagnostic menu, see section *8 Control system*, group *8.4.11.4 EL-STEERING*, menu 2.

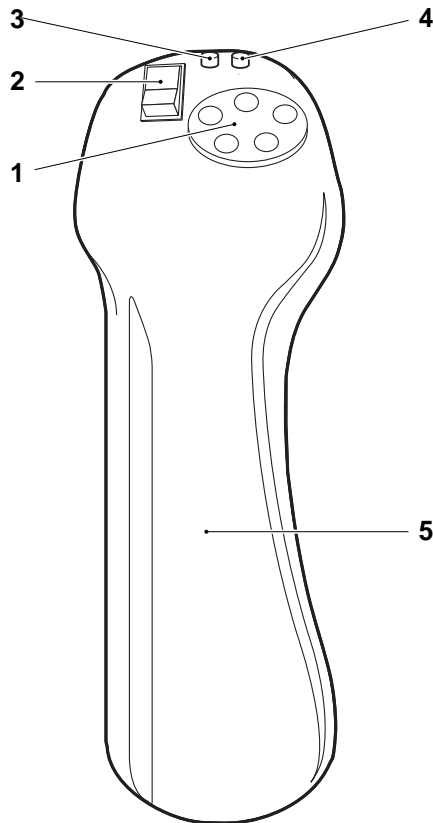

1. Mini-wheel
2. Travel direction selector (F / N / R)
3. Switch, mini-wheel activation
4. Acoustic signal
5. Armrest

000583

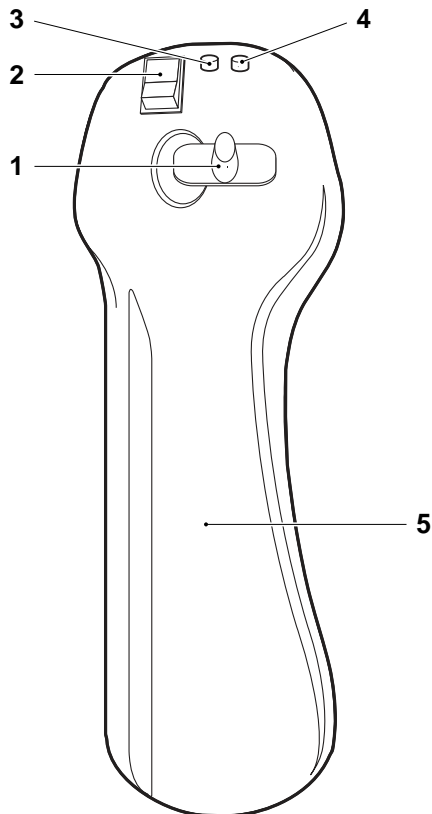

1. Joystick
2. Travel direction selector (F / N / R)
3. Switch, joystick activation
4. Acoustic signal
5. Armrest

Acoustic signal

The acoustic signal is used to activate the signal horn when the mini-wheel is activated. The switch is supplied voltage by and sends a voltage signal to the cab control unit (D790-1).

The signals can be read from the diagnostic menu, see section *8 Control system*, group *8.4.11.4 EL-STEERING*, menu 2.

5.1.3 Joystick

Joystick, description



On machines with joystick, the machine is steered with an electric control. A directional valve actuates the steering cylinder.

The joystick is integrated in the left armrest. The controls consist of a sliding potentiometer and three switches to activate lever steering, select direction of travel and activate the horn.

NOTE

Lever steering is deactivated if the standard steering wheel is used.

Mini-wheel or lever steering can only be activated at speeds below 3 km/h.

Joystick

The sliding potentiometer is supplied voltage by the cab control unit (D790-1) and sends it a voltage signal proportional to movement to indicate steering deflection.

The signals can be read from the diagnostic menu, see section *8 Control system*, group *8.4.11.4 EL-STEERING*, menu 1.

The relationship between the deflection of the joystick and that of the wheels can be set to 31 different settings - from linear to extremely progressive. It is also possible to set how steering deflection is to be adapted based on machine speed. This is done via the diagnostic menus; see section *8 Control system*, group *8.5.1 Initiation*.

Joystick position (left, centre, right) can be calibrated with the diagnostic menus; see section *8 Control system*, group *8.5.2.2 Calibrate steering*.

Switch, joystick activation

The joystick activation switch (position 3) activates steering with the joystick. The switch is supplied voltage by and sends a voltage signal to the cab control unit (D790-1).

The signals can be read from the diagnostic menu, see section *8 Control system*, group *8.4.11.4 EL-STEERING*, menu 2.

000900

Travel direction selector

The travel direction selector is used to choose direction of travel (forward or reverse) when lever steering is activated. The switch is supplied voltage by and sends a voltage signal to the cab control unit (D790-1).

The signals can be read from the diagnostic menu, see section *8 Control system*, group *8.4.11.4 EL-STEERING*, menu 2.

Acoustic signal

The acoustic signal is used to activate the horn when the lever steering is activated. The switch is supplied voltage by and sends a voltage signal to the cab control unit (D790-1).

The signals can be read from the diagnostic menu, see section *8 Control system*, group *8.4.11.4 EL-STEERING*, menu 2.

5.2 Power assisted system

Power assisted system, function description (hydraulic oil pump alternative Rexroth)

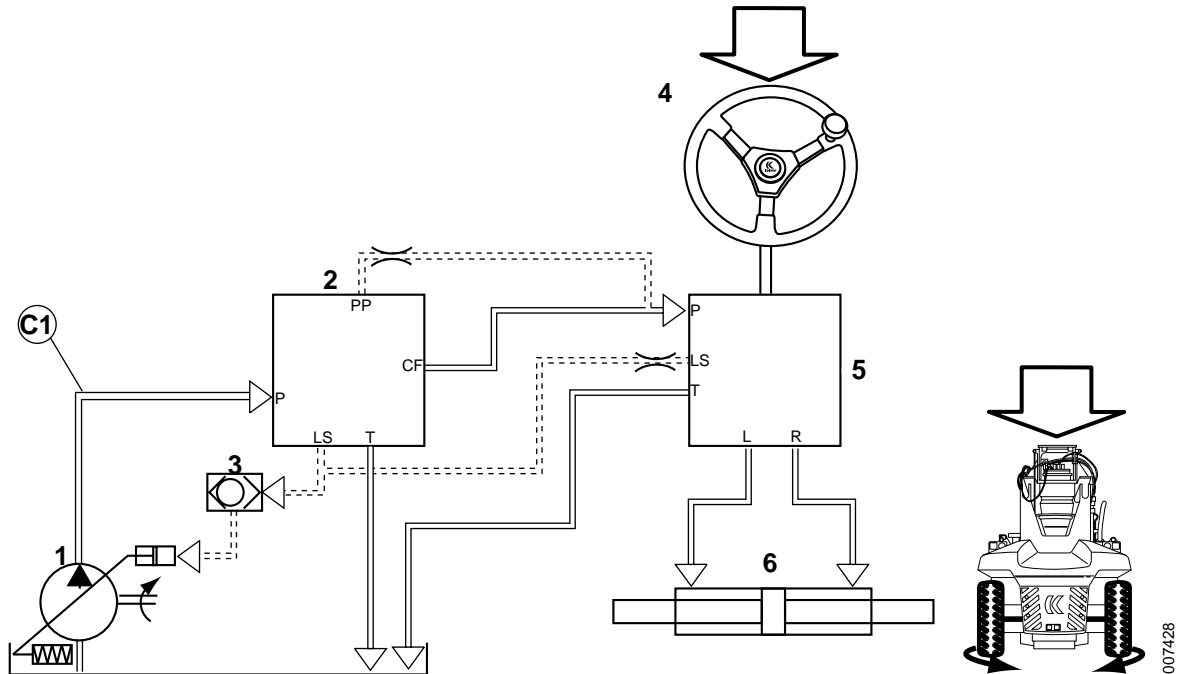

Pos	Explanation	Signal description	Reference
1	The hydraulic oil pumps pump oil to the priority valve.	See pressure plate on left frame beam.	Section 10 Common hydraulics, group 10.4.2 Axial piston pump with variable displacement
2	The priority valve prioritises pressure supply to the steering valve over the working hydraulics. The priority valve also transmits a control signal to the hydraulic oil pump 3 and 4.	Checked by control system, error shown with error code.	Priority valve, description (hydraulic oil pump alternative Rexroth) page 14
3	The shuttle valve selects the strongest load signal to the main pump if hydraulic functions are activated at the same time as the steering wheel is turned.	Checked by control system, error shown with error code.	Section 10 Common hydraulics, group 10.5.3 Shuttle valve
4	The steering wheel is turned and acts on the steering valve's input shaft.	-	Section 9 Frame, body, cab and accessories, group 9.1 Controls and instruments
5	The steering valve pumps pressurised oil to the steering cylinder and transmits a load signal to the main pumps.	-	Steering valve, description page 20
6	The steering cylinder turns the wheels.	-	Steering cylinder, description page 23

Hydraulic diagram, basic machine

**Power assisted system, function description
(hydraulic oil pump alternative Sauer-Danfoss)**

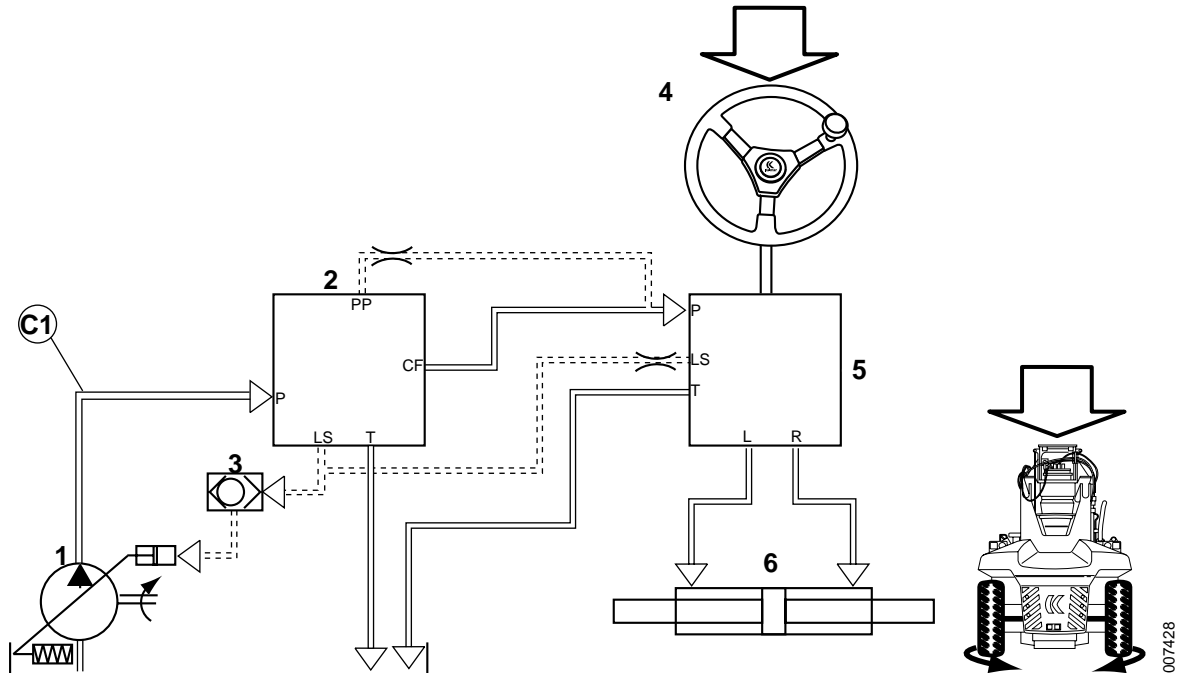

Pos	Explanation	Signal description	Reference
1	The hydraulic oil pump 2 pumps oil to the priority valve.	See pressure plate on left frame beam.	Section 10 Common hydraulics, group 10.4.2 Axial piston pump with variable displacement
2	The priority valve prioritises pressure supply to the steering valve over the working hydraulics. The priority valve also transmits a control signal to the hydraulic oil pump 2.	Checked by control system, error shown with error code.	Priority valve, description (hydraulic oil pump alternative Rexroth) page 14
3	The shuttle valve selects the strongest load signal to the main pump if hydraulic functions are activated at the same time as the steering wheel is turned.	Checked by control system, error shown with error code.	Section 10 Common hydraulics, group 10.5.3 Shuttle valve
4	The steering wheel is turned and acts on the steering valve's input shaft.	-	Section 9 Frame, body, cab and accessories, group 9.1 Controls and instruments
5	The steering valve pumps pressurised oil to the steering cylinder and transmits a load signal to the main pumps.	-	Steering valve, description page 20
6	The steering cylinder turns the wheels.	-	Steering cylinder, description page 23

Hydraulic diagram, basic machine

Joystick control/mini-wheel, function description (hydraulic oil pump alternative Rexroth)



Mini-wheel or lever steering is a steering option that makes it possible to steer the machine with an electric control.

The relationship between the deflection of the control and that of the wheels can be set to 31 different settings - from linear to extremely progressive. It is also possible to set how steering deflection is to be adapted based on machine speed. This is done via the initiation menus; see section 8 *Control system*, group 8.5.1 *Initiation*.

NOTE

The mini-wheel/lever steering is deactivated if the standard steering wheel is used.

Mini-wheel or lever steering can only be activated at speeds below 3 km/h.

Condition	Reference value	Reference
Lever steering activated	Voltage signal from switch mini-wheel/joystick control.	<i>Mini-wheel, description page 3 or Joystick, description page 4</i> Diagnostic menu, see section 8 <i>Control system</i> , group 8.4.11.4 <i>EL-STEERING</i> , menu 2
Steering wheel stationary	No signal from sensor steering wheel movement.	<i>Sensor, steering wheel movement, description page 32</i>
Speed	Below 3 km/h (at engagement)	-
Safety switch	Not activated	Section 11 <i>Common electrics</i> , group 11.2.3 <i>Safety switch</i>

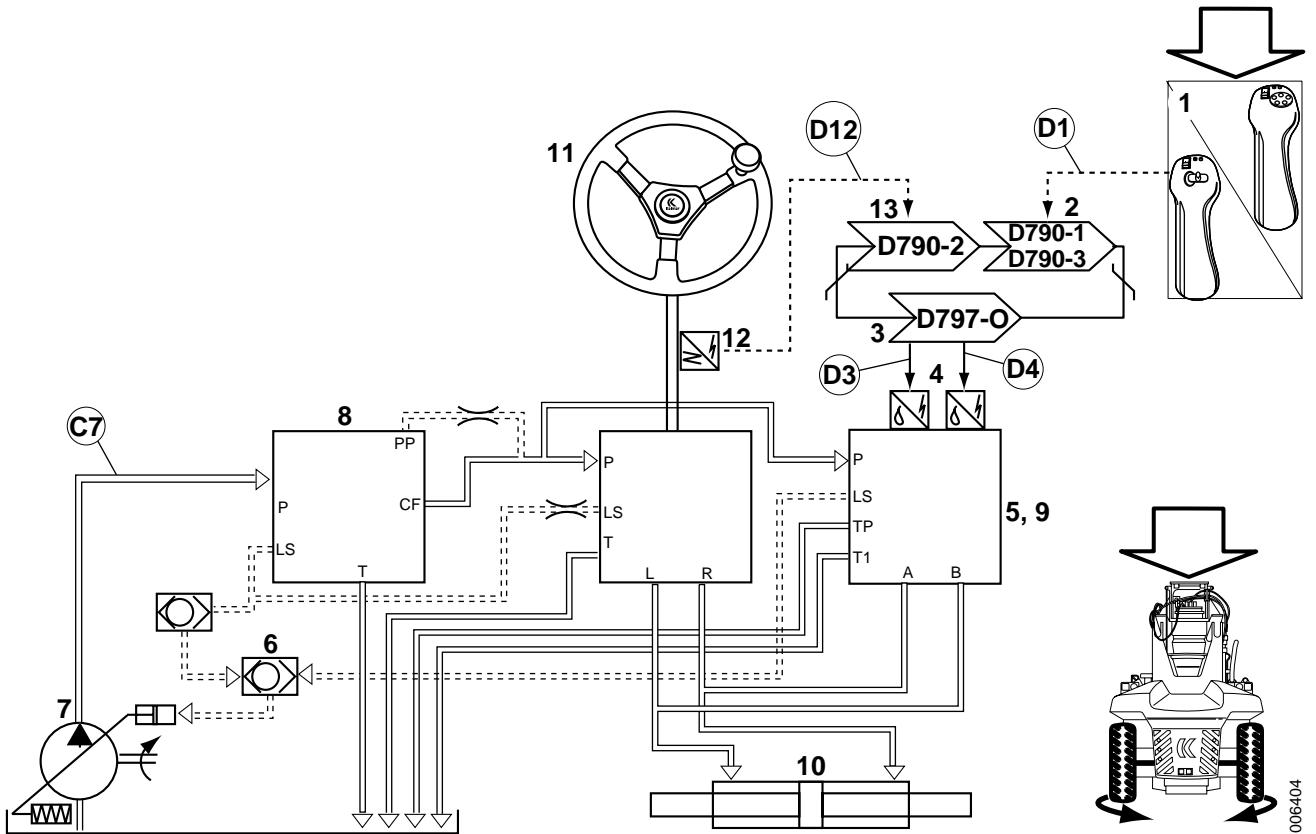

006404

Pos	Explanation	Signal description	Reference
1	The joystick switch <i>or mini-wheel switch</i> sends a voltage signal to the cab control unit (D790-1). On machines with Combi attachment the signal is sent to the cab control unit option (D790-3).	Signal 1, U = 0.5 - 4.5 V Signal 2, U = 0.5 - 4.5 V (mini-wheel only)	<i>Mini-wheel, description page 3 or Joystick, description page 4</i> D1: Diagnostic menu, see section 8 Control system , group 8.4.11.4 EL-STEERING, menu 1
2	The cab control unit (D790-1) transmits the desired steering deflection on the CAN bus. On machines with Combi attachment the cab control unit option (D790-3) sends steering deflection on the CAN bus.	Checked by control system; error indicated with error code.	Section 11 Common electrics, group 11.5.3.1 Cab control unit
3	Control unit, frame option (D797-O) supplies voltage to the solenoid valve for steering right (Y636R) <i>or the solenoid valve for steering left (Y636L)</i> .	I = 350–550 mA	Section 11 Common electrics, group 11.5.3.4 Control unit, frame option D3: Diagnostic menu, see section 8 Control system , group 8.4.11.4 EL-STEERING, menu 4 and 5

Pos	Explanation	Signal description	Reference
4	The solenoid valve, steering right (Y636R) or solenoid valve, steering left (Y636L) pressurises the steering slide in the solenoid valve for lever steering or mini-wheel.	-	<i>Control valve for lever steering or mini-wheel, description page 28</i> D4: Diagnostic menu, see section 8 <i>Control system</i> , group 8.4.11.4 <i>EL-STEERING</i> , menu 4 and 5
5	The solenoid valve for lever control or mini-wheel sends a load signal to shuttle valve, steering.	-	<i>Control valve for lever steering or mini-wheel, description page 28</i>
6	The shuttle valve selects the strongest load signal to hydraulic oil pump 3 and 4 if hydraulic functions are activated at the same time as the steering wheel is turned.	-	<i>Shuttle valve for mini-wheel or lever control, description page 31</i>
7	Hydraulic oil pumps 3 and 4 pump oil from the hydraulic oil tank.	See pressure plate on left frame beam.	Section 10 <i>Common hydraulics</i> , group 10.4.2 <i>Axial piston pump with variable displacement</i>
8	The priority valve prioritises pressure supply to the steering valve over the working hydraulics. The priority valve also transmits a control signal to the hydraulic oil pump 3 and 4.	See pressure plate on left frame beam.	<i>Priority valve page 14</i>
9	The slide changes position and pressurises the steering cylinder.	-	<i>Control valve for lever steering or mini-wheel, description page 28</i>
10	The steering cylinder turns the wheels.	-	<i>Steering cylinder, description page 23</i>
11	The steering wheel is turned and acts on the steering valve's input shaft.	-	Section 9 <i>Frame, body, cab and accessories</i> , group 9.1 <i>Controls and instruments</i>
12	Sensor steering axle sends a voltage signal to Control unit, cab (D790-1).	U = 24 V	<i>Sensor, steering wheel movement, description page 32</i> D12: Diagnostic menu, see section 8 <i>Control system</i> , group 8.4.11.4 <i>EL-STEERING</i> , menu 3
13	The cab control unit (D790-1) transmits the stop steering on the CAN bus.	Checked by control system; error indicated with error code.	Section 11 <i>Common electrics</i> , group 11.5.3.1 <i>Cab control unit</i>

Hydraulic diagram, joystick control

Joystick control/mini-wheel, function description (hydraulic oil pump alternative Sauer-Danfoss)



Mini-wheel or lever steering is a steering option that makes it possible to steer the machine with an electric control.

The relationship between the deflection of the control and that of the wheels can be set to 31 different settings - from linear to extremely progressive. It is also possible to set how steering deflection is to be adapted based on machine speed. This is done via the initiation menus; see section 8 *Control system*, group 8.5.1 *Initiation*.

NOTE

The mini-wheel/lever steering is deactivated if the standard steering wheel is used.

Mini-wheel or lever steering can only be activated at speeds below 3 km/h.

Condition	Reference value	Reference
Lever steering activated	Voltage signal from switch mini-wheel/joystick control.	<i>Mini-wheel, description page 3 or Joystick, description page 4</i> Diagnostic menu, see section 8 <i>Control system</i> , group 8.4.11.4 <i>EL-STEERING, menu 2</i>
Steering wheel stationary	No signal from sensor steering wheel movement.	<i>Sensor, steering wheel movement, description page 32</i>
Speed	Below 3 km/h (at engagement)	-
Safety switch	Not activated	Section 11 <i>Common electrics</i> , group 11.2.3 <i>Safety switch</i>

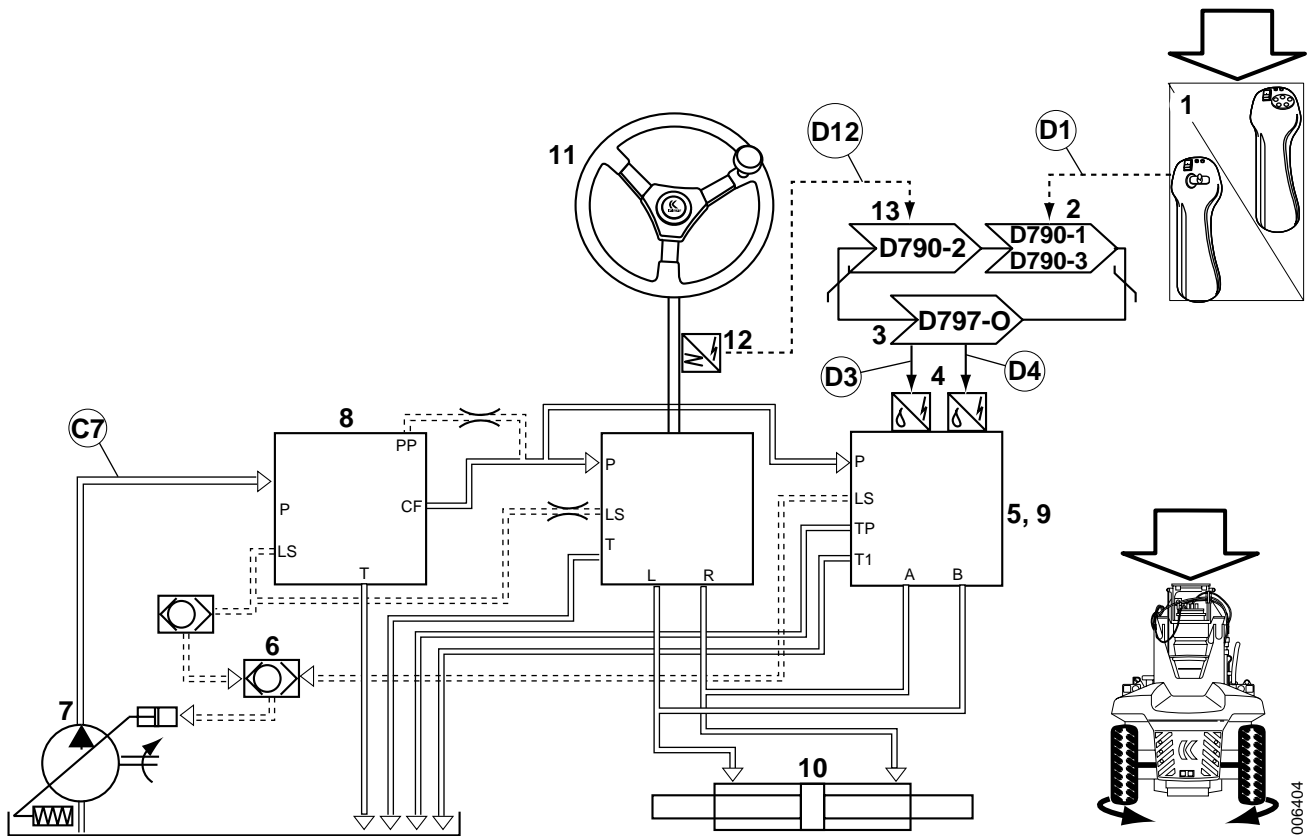

Pos	Explanation	Signal description	Reference
1	The joystick switch <i>or</i> mini-wheel switch sends a voltage signal to the cab control unit (D790-1). On machines with Combi attachment the signal is sent to the cab control unit option (D790-3).	Signal 1, U = 0.5 - 4.5 V Signal 2, U = 0.5 - 4.5 V (mini-wheel only)	<i>Mini-wheel, description page 3 or Joystick, description page 4</i> D1: Diagnostic menu, see section 8 <i>Control system</i> , group 8.4.11.4 <i>EL-STEERING, menu 1</i>
2	The cab control unit (D790-1) transmits the desired steering deflection on the CAN bus. On machines with Combi attachment the cab control unit option (D790-3) sends steering deflection on the CAN bus.	Checked by control system; error indicated with error code.	Section 11 <i>Common electrics</i> , group 11.5.3.1 <i>Cab control unit</i>
3	Control unit, frame option (D797-O) supplies voltage to the solenoid valve for steering right (Y636R) <i>or</i> the solenoid valve for steering left (Y636L).	I = 350–550 mA	Section 11 <i>Common electrics</i> , group 11.5.3.4 <i>Control unit, frame option</i> D3: Diagnostic menu, see section 8 <i>Control system</i> , group 8.4.11.4 <i>EL-STEERING, menu 4 and 5</i>

Pos	Explanation	Signal description	Reference
4	The solenoid valve, steering right (Y636R) or solenoid valve, steering left (Y636L) pressurises the steering slide in the solenoid valve for lever steering or mini-wheel.	-	<i>Control valve for lever steering or mini-wheel, description page 28</i> D4: Diagnostic menu, see section 8 <i>Control system</i> , group 8.4.11.4 <i>EL-STEERING</i> , menu 4 and 5
5	The solenoid valve for lever control or mini-wheel sends a load signal to shuttle valve, steering.	-	<i>Control valve for lever steering or mini-wheel, description page 28</i>
6	The shuttle valve selects the strongest load signal to hydraulic oil pump 2 if hydraulic functions are activated at the same time as the steering wheel is turned.	-	<i>Shuttle valve for mini-wheel or lever control, description page 31</i>
7	Hydraulic oil pump 2 pumps oil from the hydraulic oil tank.	See pressure plate on left frame beam.	Section 10 <i>Common hydraulics</i> , group 10.4.2 <i>Axial piston pump with variable displacement</i>
8	The priority valve prioritises pressure supply to the steering valve over the working hydraulics. The priority valve also transmits a control signal to the hydraulic oil pump 2.	See pressure plate on left frame beam.	<i>Priority valve page 14</i>
9	The slide changes position and pressurises the steering cylinder.	-	<i>Control valve for lever steering or mini-wheel, description page 28</i>
10	The steering cylinder turns the wheels.	-	<i>Steering cylinder, description page 23</i>
11	The steering wheel is turned and acts on the steering valve's input shaft.	-	Section 9 <i>Frame, body, cab and accessories</i> , group 9.1 <i>Controls and instruments</i>
12	Sensor steering axle sends a voltage signal to Control unit, cab (D790-1).	U = 24 V	<i>Sensor, steering wheel movement, description page 32</i> D12: Diagnostic menu, see section 8 <i>Control system</i> , group 8.4.11.4 <i>EL-STEERING</i> , menu 3
13	The cab control unit (D790-1) transmits the stop steering on the CAN bus.	Checked by control system; error indicated with error code.	Section 11 <i>Common electrics</i> , group 11.5.3.1 <i>Cab control unit</i>

Hydraulic diagram, joystick control

5.2.1 Hydraulic oil pump

Hydraulic oil pump, general (hydraulic oil pump alternative Rexroth)

Steering is supplied oil by the hydraulic oil pumps 3 and 4, see section 10 *Common hydraulics*, group 10.4 *Pumps*.

Hydraulic oil pump, general (hydraulic oil pump alternative Sauer-Danfoss)

Steering is supplied oil by the hydraulic oil pump 2, see section *10 Common hydraulics*, group *10.4 Pumps*.

5.2.2 Priority valve

Priority valve, description (hydraulic oil pump alternative Rexroth)

The priority valve divides the oil flow from the main pump 3 and 4 so that there is always oil to the steering valve. The residual flow goes to working hydraulics.

The priority valve is load sensing and pilot pressure compensating. Load sensing means that the valve adapts the control signal to the steering valve's consumption. Pilot pressure compensating means that the priority valve compensates for the pressure drop between the priority valve and steering valve via a separate line.

The priority valve has a built-in pressure limiter on the load signal. The pressure limiter maximises the load signal's pressure.

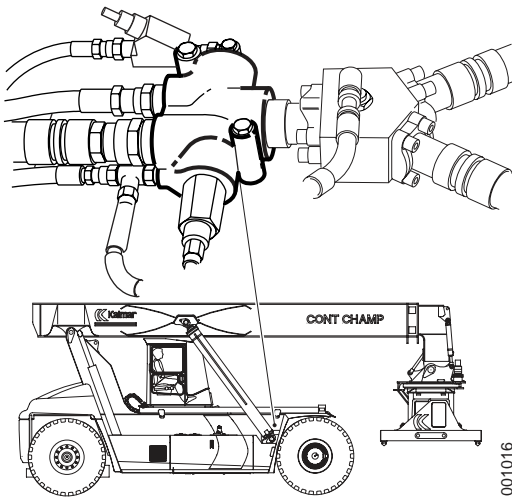

Steering pressure, checking (hydraulic oil pump alternative Rexroth)

NOTE

Read the safety instructions for oil before working, see section B Safety.

- 1 Operate and warm up the machine so that the hydraulic oil reaches operating temperature, 50 °C.
- 2 Machine in service position, see section *B Safety*.
- 3 Depressurising removed.

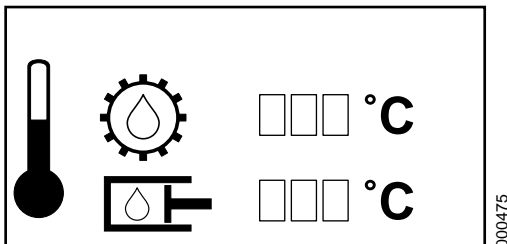

Operating menu, hydraulic oil temperature

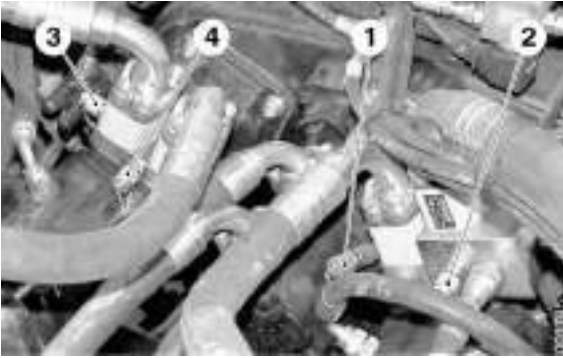

Measuring outlet, hydraulic oil pumps

1. Hydraulic oil pump 1
2. Hydraulic oil pump 2
3. Hydraulic oil pump 2
4. Hydraulic oil pump 4

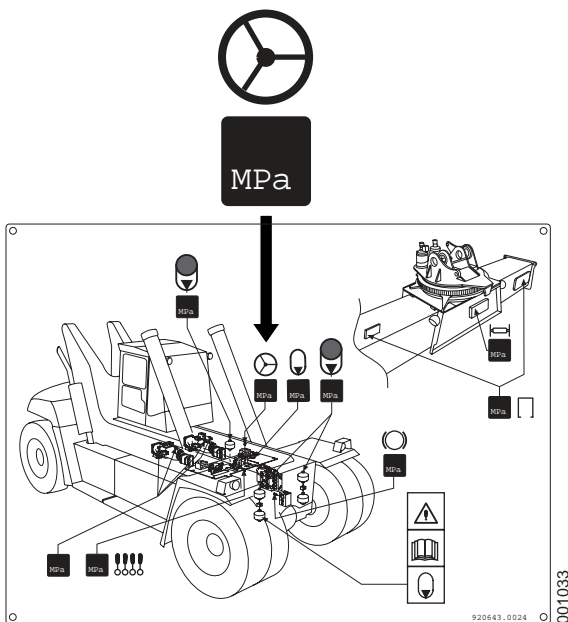

- 4 Connect the pressure gauge to the measuring outlet for hydraulic oil pump 3 or 4.
- 5 Start the engine and increase engine speed to approx. 1200 rpm.

- 6 Turn the steering wheel fully and read pump pressure during steering wheel movement. Compare this to the steering pressure on the hydraulics plate. The max. pressure measured on the pump should be **1.5 MPa** more than the steering pressure on the hydraulics plate.
- 7 Stop the engine and turn the starter key to position I.
- 8 Depressurising removed.
- 9 Turn the start key to position 0 and turn off the main electric power.
- 10 Remove the pressure gauge and fit the protective cap on the measuring outlet.

Priority valve, description (hydraulic oil pump alternative Sauer-Danfoss)

The priority valve divides the oil flow from the main pump 2 so that there is always oil to the steering valve. The residual flow goes to working hydraulics.

The priority valve is load sensing and pilot pressure compensating. Load sensing means that the valve adapts the control signal to the steering valve's consumption. Pilot pressure compensating means that the priority valve compensates for the pressure drop between the priority valve and steering valve via a separate line.

The priority valve has a built-in pressure limiter on the load signal. The pressure limiter maximises the load signal's pressure.

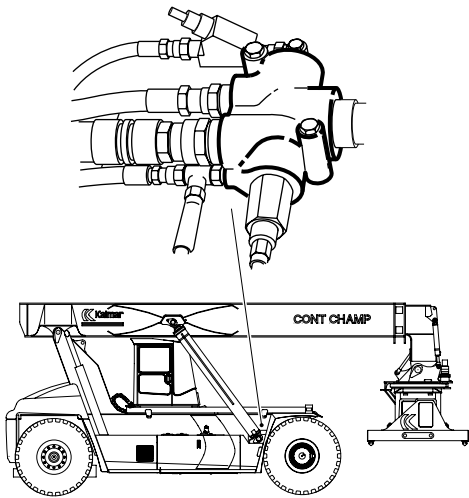

011345

Steering pressure, checking (hydraulic oil pump alternative Sauer-Danfoss)

NOTE

Read the safety instructions for oil before working, see section *B Safety*.

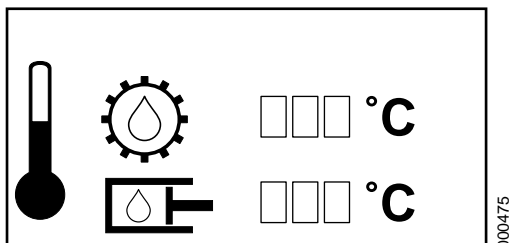

000475

Operating menu, hydraulic oil temperature



Measuring outlet, hydraulic oil pumps

1. Hydraulic oil pump 1
2. Hydraulic oil pump 2

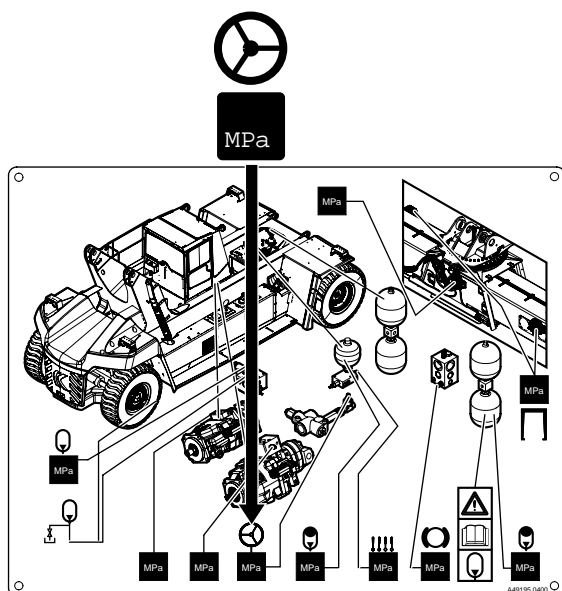

- 1 Operate and warm up the machine so that the hydraulic oil reaches operating temperature, 50 °C.
- 2 Machine in service position, see section *B Safety*.
- 3 Depressurising removed.
- 4 Connect the pressure gauge to the measuring outlet for hydraulic oil pump 2.
- 5 Start the engine and increase engine speed to approx. 1200 rpm.
- 6 Turn the steering wheel fully and read pump pressure during steering wheel movement. Compare this to the steering pressure on the hydraulics plate. The max. pressure measured on the pump should be **1.5 MPa** more than the steering pressure on the hydraulics plate.
- 7 Stop the engine and turn the starter key to position I.
- 8 Depressurising removed.
- 9 Turn the start key to position 0 and turn off the main electric power.
- 10 Remove the pressure gauge and fit the protective cap on the measuring outlet.

Priority valve, replacement

NOTE

Read the safety instructions for oil before working, see section B Safety.

- 1 Machine in service position, see section B Safety.
- 2 Depressurise the brake and hydraulic systems, see section B Safety.
- 3 Turn the start key to position 0 and turn off the main electric power.
- 4 Mark up and detach the hydraulic hoses from the priority valve.



NOTE

Plug all connections immediately to protect the brake system from impurities.

- 5 Remove the priority valve attaching bolts.
- 6 Release the priority valve from the collection block.
- 7 Remove the priority valve.
- 8 Transfer the connection adapters to the new priority valve.

NOTE

Transfer one connection at a time so that the marking is not mixed up.

- 9 Connect the new priority valve to the collection block.



CAUTION

Do not tighten the hydraulic connection between priority valve and collection block before all other connections and attaching bolts are fitted.

Stresses in the priority valve may result in incorrect function.

- 10 Fit the priority valve attaching bolts.
- 11 Connect the hydraulic hoses to the priority valve.
- 12 Check that the collection block is not pressing against the priority valve.
- 13 Tighten the hydraulic connection between priority valve and collection block.





- 14 Close the drain valve on the accumulator charging valve.

NOTE

Check that the accumulator drain valve is fully closed and tighten the lock ring.

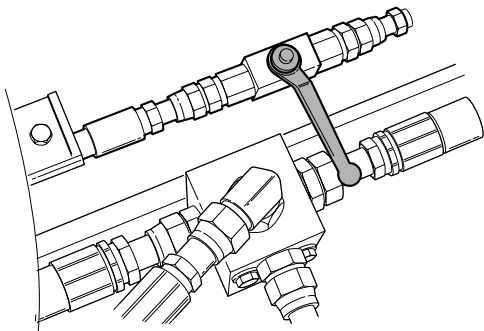

Relief valve for top lift, the figure shows a closed valve.

- 15 Close the relief valve for top lift.

CAUTION

Hydraulic oil may be directed the wrong way.

Risk of damage to the fine filter for hydraulic oil.

Check that the relief valve for top lift is closed before starting the engine.

- 16 Start the engine and check that the hydraulic connections at the priority valve are sealed.
- 17 Check the oil level in the hydraulic oil tank with the lift cylinders fully down and the extension cylinder fully in. The oil level should be in the centre of the level glass. Top up if necessary, for grade see section *F Technical data*.



CAUTION

Overfilling of oil, leakage, and environmental damage.

The hydraulic oil level is checked with the boom completely lowered and retracted.

- 18 Check steering pressure, see *Steering pressure, checking (hydraulic oil pump alternative Rexroth) page 14*.

5.2.3 Steering valve

Steering valve, description

The steering valve is a "progressive, closed centre, non-reaction valve" with load signal connection to the priority valve.

The load signal generates load-dependent control of oil flow from the priority valve to the steering valve. Closed centre means that the steering valve is closed in its neutral position. This is necessary so that signal pressure can be connected to the steering valve.

The steering valve consists of a gear pump and a distribution valve. When the steering wheel is turned, oil flows from the main pump over the gear pump to the distribution valve, which guides oil to the steering cylinder. The gear pump ensures that the oil flow fed to the cylinder is proportional to the steering wheel angle.

There are double shock and anti-cavitation valves in the steering valve. The shock valves protect the hydraulics against pressure spikes which can arise from impacts on the steering wheels. The anti-cavitation valves (non-return valves) protect against vacuum on the piston's rear side, which can lead to cavitation.

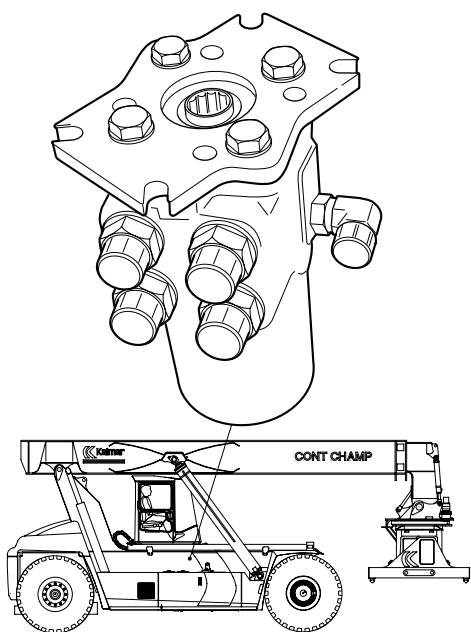

001082

Steering valve, replacement

NOTE

Read the safety instructions for oil before working, see section B Safety.

- 1 Remove the cover plates over the engine compartment.
- 2 Slide the cab forward so that the control valve is accessible from below.
- 3 Stop the engine and turn the starter key to position I.
- 4 Depressurise the brake and hydraulic systems, see section B Safety.
- 5 Turn the start key to position 0 and turn off the main electric power.

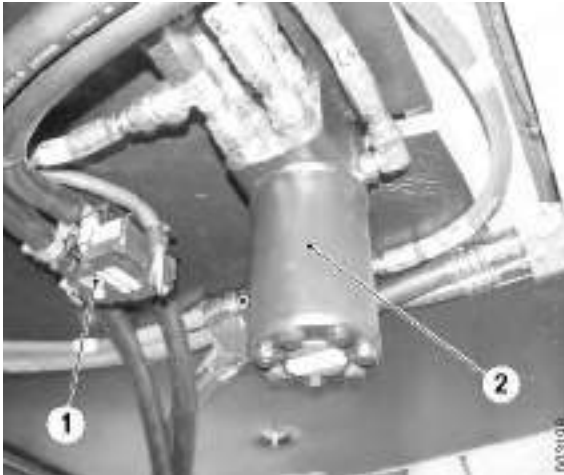

1. Water valve
2. Steering valve

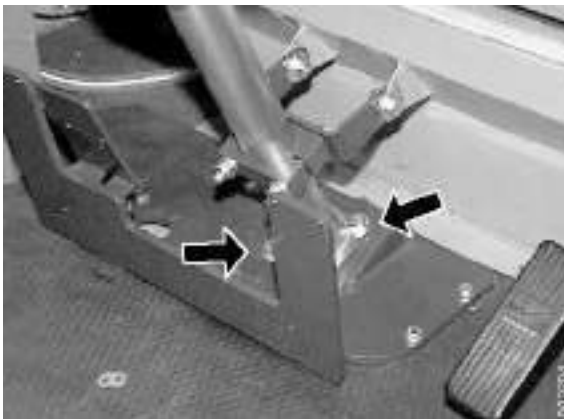

- 6 Detach the steering valve from the brake pedal.
Remove the steering valve attaching bolts and lower the steering valve.
- 7 Mark up and detach the hydraulic hoses from the steering valve.

NOTE

Plug all connections immediately to protect the brake system from impurities.

- 8 Remove the steering valve.
- 9 Transfer the connection adapters to the new steering valve.

NOTE

Transfer one at a time so that the marking is not mixed up.

- 10 Connect the hydraulic hoses to the steering valve in accordance with the marking.

NOTE

Check that the O-rings are intact and are fitted correctly.

- 11 Connect the new steering valve to the brake pedal.
Place the steering valve and check that the steering wheel shaft's splines enter straight in the steering valve's slot. Install the attaching bolts.

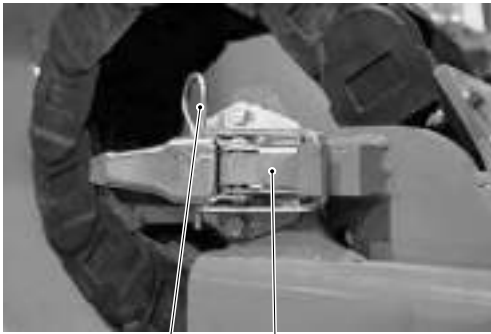
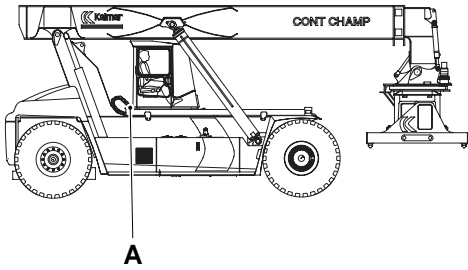

000270

- A. Location, lock handle
- B. Lock pin
- C. Lock handle for securing cab

12 On machines with manual sliding cab:

Lock the cab in its rearmost position with both locking catches.



13 Close the drain valve on the accumulator charging valve.

NOTE

Check that the accumulator drain valve is fully closed and tighten the lock ring.

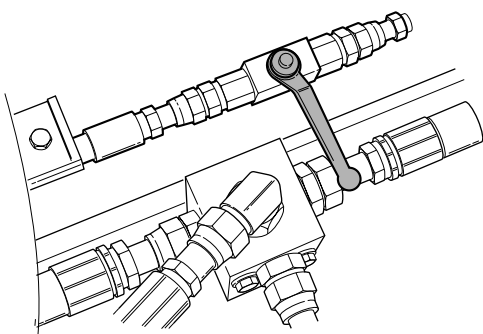

010475

Relief valve for top lift, the figure shows a closed valve.

14 Close the relief valve for top lift.

CAUTION

Hydraulic oil may be directed the wrong way.

Risk of damage to the fine filter for hydraulic oil.

Check that the relief valve for top lift is closed before starting the engine.



- 15 Turn on the main electric power and start the engine.
- 16 Check that the connections on the steering valve are sealed.
- 17 Steer very carefully a few times right - left, to bleed the steering valve and steering cylinder.
- 18 Check the oil level in the hydraulic oil tank with the lift cylinders fully down and the extension cylinder fully in. The oil level should be in the centre of the level glass. Top up if necessary, for grade see section *F Technical data*.



CAUTION

Overfilling of oil, leakage, and environmental damage.

The hydraulic oil level is checked with the boom completely lowered and retracted.

5.2.4 Steering cylinder

Steering cylinder, description

The steering cylinder acts on the wheels via the link arms. The steering cylinder is a double-acting hydraulic cylinder.

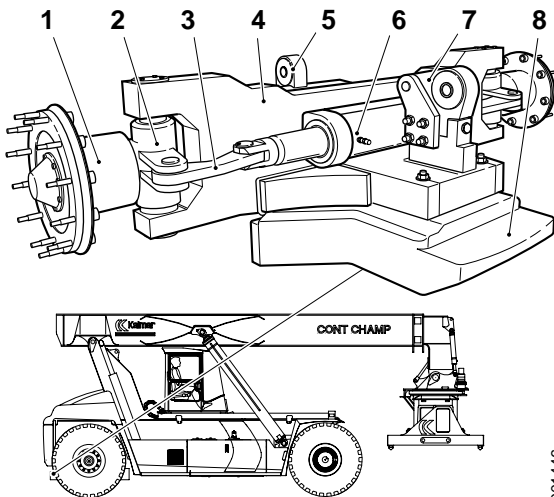

001446

1. Wheel hub
2. Wheel spindle
3. Link arm
4. Steering axle
5. Suspension
6. Steering cylinder
7. Rear mounting
8. Counterweight

Steering cylinder, replacement

NOTE

Read the safety instructions for oil before working, see section B Safety.

- 1 Park the machine with the wheels fully turned so that the steering cylinder can be lifted out to one side.
- 2 Machine in service position, see section B Safety.
- 3 Depressurise the brake and hydraulic systems, see section B Safety.
- 4 Disconnect the link arms from the steering cylinder.
- 5 Mark up and disconnect the hydraulic hoses from the steering cylinder.

NOTE

Plug all connections immediately to protect the brake system from impurities.

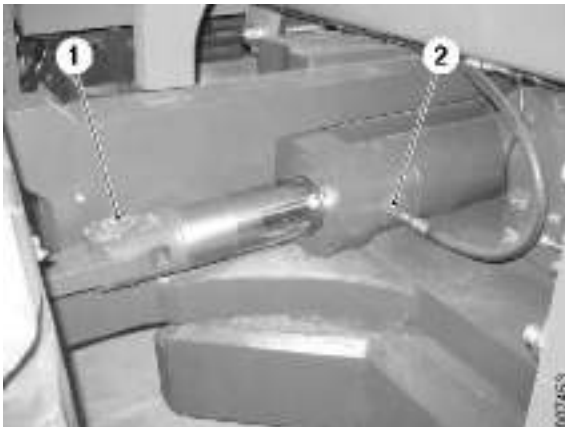

1. Link arm mounting
2. Hydraulic connection



Attaching bolts steering cylinder.

- 6 Remove the steering cylinder's attaching bolts.
- 7 Change the steering cylinder. Lift aside the steering cylinder.

NOTE

The steering cylinder is heavy, use lifting equipment.

- 8 Support the new steering cylinder so that the holes in the attaching bolts are lined up directly opposite the holes in the steering axle.
- 9 Fit and lubricate the steering cylinder attaching bolts. Tighten them crosswise in steps until 680 Nm is achieved.
- 10 Transfer parts to the new steering cylinder.

NOTE

Check that the O-rings are intact and fitted correctly.

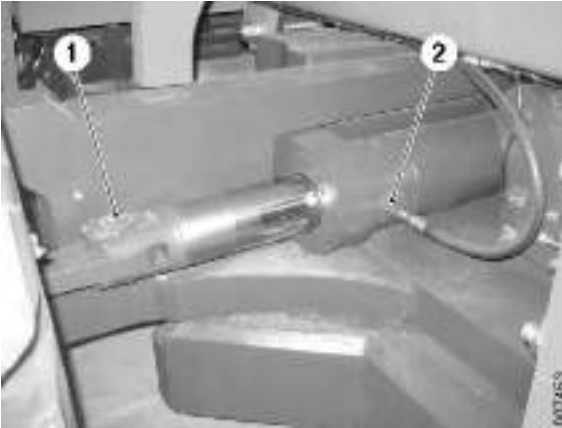

1. Link arm mounting
2. Hydraulic connection



- 11 Fit the link arms to the steering cylinder.
- 12 Connect the hydraulic hoses to the steering cylinder.

NOTE

Check that the O-rings are intact and fitted correctly.

- 13 Close the drain valve on the accumulator charging valve.

NOTE

Check that the accumulator drain valve is fully closed and tighten the lock ring.

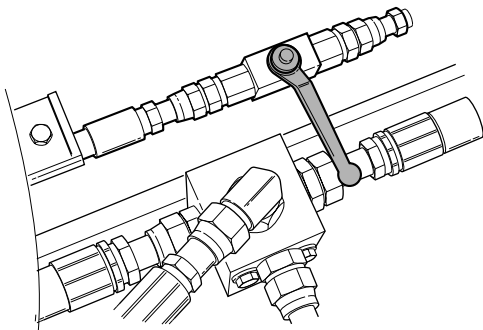

Relief valve for top lift, the figure shows a closed valve.

- 14 Close the relief valve for top lift.



CAUTION

Hydraulic oil may be directed the wrong way.

Risk of damage to the fine filter for hydraulic oil.

Check that the relief valve for top lift is closed before starting the engine.

- 15 Start the engine and check for leaks.



- 16 Check the oil level in the hydraulic oil tank with the lift cylinders fully down and the extension cylinder fully in. The oil level should be in the centre of the level glass. Top up if necessary, for grade see section *F Technical data*.

! **CAUTION**

Overfilling of oil, leakage, and environmental damage.

The hydraulic oil level is checked with the boom completely lowered and retracted.

Hydraulic cylinders, repairs

See section *10 Common hydraulics*, group *10.7.1 Hydraulic cylinders*.

5.2.5 Steering axle cradle

Steering axle cradle, general

See section *6 Suspension*, group *6.2.1 Steering axle cradle*.