



Original instructions

Diesel truck

RX70-16
RX70-18
RX70-20



7311 7312 7313
174749 EN - 03/2017

first in intralogistics

Address of manufacturer and contact details ▷

STILL GmbH
Berzeliusstraße 10
22113 Hamburg, Germany
Tel. +49 (0) 40 7339-0
Fax: +49 (0) 40 7339-1622
Email: info@still.de
Website: <http://www.still.de>



1 Foreword

Your truck	2
Description of the truck	2
General	4
CE labelling	5
EC declaration of conformity in accordance with Machinery Directive	6
Accessories overview	7
Overview	8
Nameplate	10
Production number	11
StVZO (Road Traffic Licensing Regulations) information	11
Use of truck	11
Proper usage	11
Proper use during towing	12
Impermissible use	12
Place of use	13
Using working platforms	14
Information about documentation	15
Documentation scope	15
Supplementary documentation	16
Issue date and topicality of the operating instructions	17
Copyright and trademark rights	17
Explanation of information symbols used	17
List of abbreviations	18
Definition of directions	20
Schematic views	20
Environmental considerations	22
Packaging	22
Disposal of components and batteries	22

2 Safety

Definition of responsible persons	24
Operating company	24
Specialist	24
Drivers	25
Essentials for safe operation	27
Insurance cover on company premises	27
Changes and retrofitting	27
Changes to the overhead guard and roof loads	29
Warning regarding non-original parts	29

Damage, defects and misuse of safety systems	30
Tyres	30
Medical equipment	32
Exercise caution when handling gas springs and accumulators	32
Length of the fork arms	33
Residual risk	34
Residual dangers, residual risks	34
Special risks associated with using the truck and attachments	35
Overview of hazards and countermeasures	38
Danger to employees	41
Safety inspections	42
Regular safety inspection of the truck	42
Checking the diesel engine emissions	42
Trucks with particle filters	43
Insulation testing	44
Safety regulations when handling consumables	45
Permissible consumables	45
Oils	45
Hydraulic fluid	46
Battery acid	47
Diesel fuel	48
Coolant and cooling fluid	50
Disposal of consumables	50
Emissions	52
3 Overviews	
General view	56
Driver's compartment	57
Operating and display elements	58
Display and operating unit	58
Operating devices for hydraulic and driving functions	59
Double mini-lever	60
Three-way mini-lever	61
Four-way mini-lever	62
Joystick 4Plus	63
Fingertip	64
Mini console	65

4 Operation

Testing and activities before daily use	68
Visual inspections	68
Checking the cooling fluid level	71
Checking the engine oil level	72
Climbing in and out of the truck	73
Shelves and cup holders	74
Adjusting the MSG 65/MSG 75 driver's seat	75
Adjusting the armrest	79
Adjusting the steering column	80
Unlocking the emergency off switch	80
Switching on the key switch	81
Access authorisation with PIN code (variant)	84
Operating the signal horn	94
Seat belt	94
Driver's cab	97
Starting the engine	98
Checking the brake system for correct function	100
Checking the steering system for correct function	101
Checking the emergency off function	101
Zero adjustment of the load measurement (variant)	102
Checking the vertical lift mast position (variant) for correct function	104
Operation of the display operating unit	105
Displays	105
Adjusting the displays	106
Symbols in the display	106
Setting the date or time	111
Resetting the daily kilometres and daily operating hours	111
Setting the language	112
Soft key button for operating various equipment variants	112
Configuring Blue-Q efficiency mode	113
Blue-Q efficiency mode	115
Functional description	115
Effects on additional consumers	115
Switching efficiency mode Blue-Q on and off	116
Driving	117
Safety regulations when driving	117
Driveways	119
Setting the drive programs	122
Selecting the drive direction	122
Actuating the drive direction switch, mini-lever version	123

Actuating the vertical rocker switch for the "drive direction", joystick 4Plus version	124
Actuating the drive direction switch, fingertip version	124
Actuating the drive direction switch, mini-console version	125
Starting to drive	125
Starting drive mode, dual-pedal version (variant)	127
Operating the service brake	130
Parking brake	131
Actuating the mechanical parking brake	131
Actuating the electric parking brake	133
Steering	138
Driving on ascending and descending gradients	139
Reducing speed with a raised load (variant)	140
Automatic shut-off of the internal combustion engine (variant)	140
Parking	141
Parking the truck securely and switching it off	141
Wheel chock (variant)	142
Lifting	143
Lifting system variants	143
Automatic lift cut out (variant)	143
Lift mast vertical position (variant)	144
Types of lift mast	148
Malfunctions during lifting mode	150
Hydraulic blocking function	151
Lifting system operating devices	152
Controlling the lifting system using a double mini-lever	153
Controlling the lifting system using a triple mini-lever	154
Controlling the lifting system using a quadruple mini-lever	155
Controlling the lifting system using the joystick 4Plus	156
Controlling the lifting system using the fingertip	158
Changing the fork arms	159
Fork extension (variant)	161
Operation with reversible fork arms (variant)	163
Working with loads	165
Safety regulations when handling loads	165
Before taking up load	166
Load measurement (variant)	167
Picking up loads	170
Danger area	171
Transporting pallets	172
Transporting suspended loads	172
Load pick up	173

Transporting loads	177
Setting down loads	178
Driving on lifts	180
Driving on loading bridges	181
Attachments	182
Fitting attachments	182
Releasing the pressure from the hydraulic system	184
General instructions for controlling attachments	186
Controlling attachments using a double mini-lever	188
Controlling attachments using the double mini-lever and the 5th function	190
Controlling attachments using a triple mini-lever	192
Controlling attachments using the triple mini-lever and the 5th function	194
Controlling attachments using a quadruple mini-lever	196
Controlling attachments using the quadruple mini-lever and the 5th function	198
Controlling attachments via the joystick 4Plus	200
Controlling attachments using the joystick 4Plus and the 5th function	201
Controlling the attachments with the fingertip	202
Controlling attachments with the fingertip and 5th function	203
Clamp locking mechanism (variant)	205
Taking up a load using attachments	208
Auxiliary equipment	209
Switching the lighting on and off	209
Switching the rotating beacon on and off	210
Switching the hazard warning system on and off	210
Switching direction indicators on and off	211
Switching the double working spotlights on and off.	214
STILL SafetyLight (variant)	216
Operating the windscreen wiper/washer	217
Filling the washer system	217
FleetManager (variant)	217
Shock recognition (variant)	218
Cruise control (variant)	218
Driver restraint systems (variants)	222
Cab	223
Opening the cab door	223
Closing the cab door	224
Opening the side windows	224
Closing the side windows	225
Operating the interior lighting	226
Operating the rear window heating	227
Radio (variant)	227

Heating system	228
Push-up roof window (variant)	229
Clipboard (variant)	230
Trailer operation	231
Towed load	231
Coupling pin in the counterweight	232
Automatic tow coupling	234
Towing trailers	242
Display messages	244
Display content	244
Error code table	245
General messages	247
Drive-specific messages	256
Malfunctions in the electric parking brake	263
Refuelling	269
Diesel fuel - Specifications	269
Topping up the diesel fuel	273
Cleaning	275
Cleaning the truck	275
Cleaning the electrical system	277
Cleaning load chains	278
Cleaning the windows	278
After washing	279
Behaviour in emergencies	279
Emergency shutdown	279
Procedure if truck tips over	281
Emergency hammer	282
Emergency lowering	282
Emergency operation of the electric parking brake	284
Disconnecting the battery	285
Jump starting	286
Towing	288
Transporting the truck	290
Transport	290
Crane loading	292
Shutdown	295
Shutting down and storing the truck	295
Returning to service after storage	297

5 Maintenance

Safety instructions for maintenance	300
General information	300
Working on the hydraulic equipment	300
Working on the electrical equipment	301
Working on the ignition system	301
Safety devices	302
Set values	302
Lifting and jacking up	302
Working at the front of the truck	302
General maintenance information	304
Personnel qualifications	304
Information for carrying out maintenance	304
Maintenance - 1000 hours/annually	307
Maintenance — 3000 hours/every two years	311
Ordering spare parts and wearing parts	311
Quality and quantity of the required operating materials	312
Lubrication plan	313
Maintenance data table	314
Providing access to maintenance points	317
Opening the bonnet	317
Closing the bonnet	317
Installing and removing the bottom plate	318
Maintenance after first 50 operating hours	320
Maintenance during the break-in period	320
Remaining ready for operation	321
Cleaning the radiator, checking for leaks	321
Topping up the cooling fluid and checking the coolant concentration	321
Changing the air filter insert	323
Draining water from the fuel filter	325
Eberspächer particle filters - Regeneration	326
Lubricating the joints and controls	329
Maintaining the seat belt	330
Checking the driver's seat	331
Checking the door latch	332
Servicing wheels and tyres	332
Servicing the battery	334
Replacing fuses	336
Checking the hydraulic oil level	336
Checking the hydraulic system for leaks	337
Lubricating the lift mast and roller track	338

Greasing the automatic tow coupling	339
Changing the heating system fresh air filter	341
1000-hour maintenance / Annual maintenance	343
Other tasks	343
Checking the ribbed V-belt	343
Checking the exhaust gas system	343
Changing the fuel filter	344
Changing the fuel filter for Eberspächer particle filters	345
Checking the lift cylinders and connections for leaks	345
Checking the fork arms	346
Checking the reversible fork arms	346
6 Technical data	
Dimensions	348
VDI datasheet for RX70-16, RX70-18 and RX70-20	350
Ergonomic dimensions	354
Fuse assignment	356

1

Foreword

Your truck

Your truck

Description of the truck

General

The internal combustion engine-powered trucks of series RX70-16/18/20 with a load capacity of up to 2 t are equipped with a diesel-electric drive. The diesel-electric drive combines the advantages of the diesel engine with the precise control of an electric drive.

The bend-resistant and warp-resistant lift mast enables safe load handling, even with heavy loads. The comfortable driver's compartment features the most up-to-date ergonomic design to prevent signs of fatigue and increase safety.

The low centre of gravity of the truck provides stability, which is guaranteed if the truck is used according to its intended use.

Brake system

The brake system of the truck is comprised of three different brakes:

- Service brake
- Regenerative brake
- Parking brake

The service brake is based on a wear-free, oil-immersed multi-disc brake. This multi-disc brake is used as the service brake for heavy braking or emergency braking with the brake pedal. In the normal working mode, the regenerative brake of the electric traction motor takes effect. The regenerative brake converts the acceleration energy of the truck into electrical energy. This causes the truck to decelerate as soon as the accelerator pedal is released. Completely removing your foot from the accelerator pedal causes the truck to brake until it comes to a standstill. A parking brake ensures that the truck remains securely in place when parked.

Engine

The truck is equipped with a four-cylinder, four-stroke diesel engine. The engine is

cooled by means of a closed coolant circuit. The engine is lubricated via forced circulation lubrication. The combustion air is drawn in and cleaned by a dry air filter. Different equipment variants are available, for example a diesel particle filter.

Hydraulic system

All lift cylinders are hydraulically actuated. The required oil volume flow is realised via a gear pump, which is connected to the internal combustion engine. The proportional valve technology provides particularly sensitive movements and safe handling of the load. The hydraulic functions can be parameterised individually by the authorised service centre.

Up to three hydraulic circuits can be used to activate attachments (variant). Depending on the equipment, a hydraulic accumulator is also available in the lifting circuit for the purpose of dampening pressure peaks in the hydraulic system.

Drive concept

The internal combustion engine drives an electric generator. The generated current is directed to an electric traction motor, which drives the truck. An electronic speed controller gently provides high torque for both forwards and backwards travel.

The components for the drive unit and the lift drive are enclosed in order to prevent the ingress of dust or moisture. This means that the truck is suitable for indoor and outdoor use. In addition, all drives for traction, steering and lifting are maintenance-free.

The driving characteristics and lifting behaviour can be adapted to the application or driving habits. Five drive programmes are available for this purpose. The maximum driving speed is 22 km/h. The energy-saving mode Blue-Q reduces energy consumption by up to 10%, without impairing performance.

Your truck

Operating devices

The truck is characterised by an accessible operating concept. When purchasing the truck, a variety of controls and equipment variants are available:

- Double mini-lever
- Triple mini-lever
- Quadruple mini-lever
- Joystick 4Plus
- Fingertip switch
- Single pedal
- Dual pedal

Hands are always kept free for steering and for controlling the operational movements to allow efficient working. The forces that need to be applied for this purpose are reduced to a minimum thanks to the compact steering wheel. The simple handling of the truck is assisted by the agile steering axle.

General

The truck described in these operating instructions corresponds to the applicable standards and safety regulations.

If the truck is to be operated on public roads, it must conform to the existing national regulations for the country in which it is being used. The driving permit must be obtained from the appropriate office.

The trucks have been fitted with state-of-the-art technology. All that remains is to handle the truck safely and maintain its functionality.

These operating instructions provide the necessary information to do this. Read and observe the information provided before commissioning the truck. This will prevent accidents and ensure that the warranty remains valid.

CE labelling

The manufacturer uses CE labelling to indicate that the truck complies with the standards and regulations valid at the time of marketing. This is confirmed by the issued EC declaration of conformity. The CE labelling is attached to the nameplate.

An independent structural change or addition to the truck can compromise safety, thus invalidating the EC declaration of conformity.

The EC declaration of conformity must be carefully stored and made available to the responsible authorities.

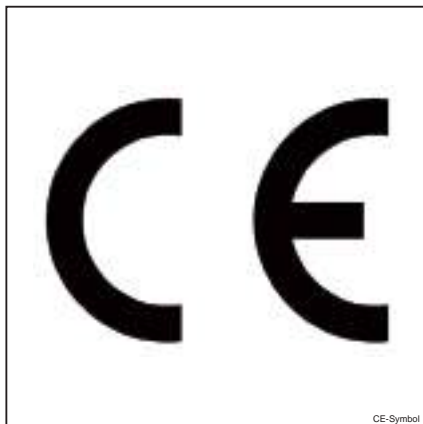

EC declaration of conformity in accordance with Machinery Directive**Declaration**

STILL GmbH
Berzeliusstraße 10
D-22113 Hamburg Germany

We declare that the

Industrial truck	according to these operating instructions
Model	according to these operating instructions

conforms to the latest version of the Machinery Directive 2006/42/EC.

Personnel authorised to compile the technical documents:

See EC compliance declaration

STILL GmbH

Accessories overview

- Key for key switch (2 pieces)
- Key for cab (variant)
- Hexagon socket wrench for emergency lowering

Your truck

Overview

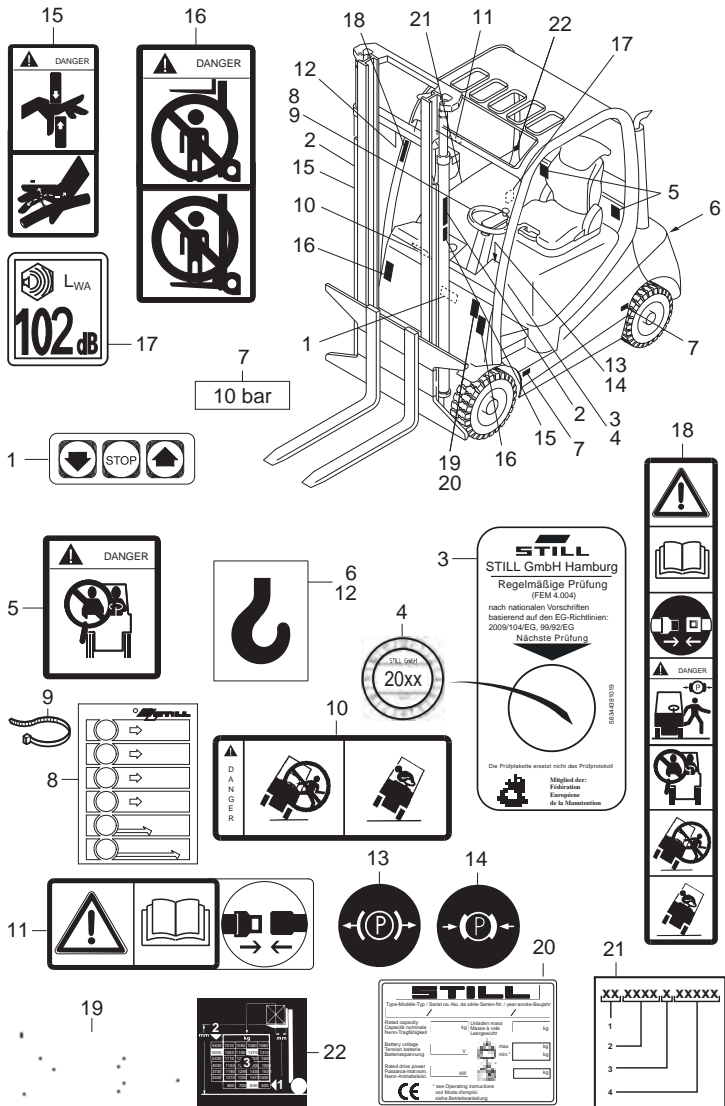

7314_003-017_V11

1	Decal information: "Dual-pedal operation" (variant)	14	Decal information: Parking brake applied
2	Manufacturer's label text	15	Warning sign: Danger due to shearing / Danger due to high fluid pressure
3	Decal information: FEM audit	16	Warning sign: Do not stand underneath the fork / Do not stand on the fork
4	Inspection sticker	17	Decal information: Sound power level
5	Warning sign: Passengers are not allowed	18	Decal information: Caution / Read the operating instructions / Fasten the seat belt / Apply the parking brake when leaving the truck / Passengers are not allowed / Do not jump off if the truck is tipping over / Lean in the opposite direction to which the truck is tipping
6	Decal information: Lifting gear attachment point	19	Decal information: StVZO (German Road Traffic Licensing Regulations) information (variant)
7	Decal information: Tyre filling pressure	20	Decal information: nameplate
8	Decal information: Driving dynamics	21	Decal information: Factory number
9	Cable strap	22	Decal information: capacity rating plate
10	Decal information: Do not jump off if the truck is tipping over / Lean in the opposite direction to which the truck is tipping		
11	Decal information: Caution / Read the operating instructions / Fasten the seat belt		
12	Decal information: Lifting gear attachment point		
13	Decal information: Parking brake released		

Your truck

Nameplate

The truck can be identified from the information on the nameplate.

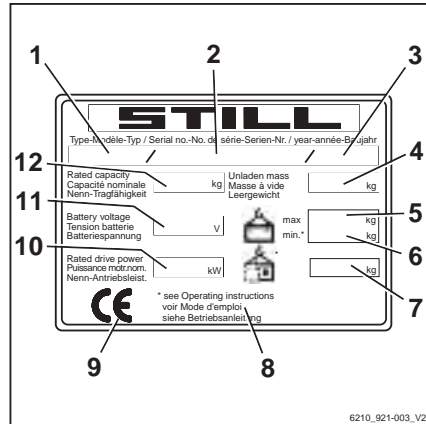

- 1 Type
- 2 Production number
- 3 Year of manufacture
- 4 Tare weight in kg
- 5 Max. permissible battery weight in kg (for electric forklift trucks only)
- 6 Min. permissible battery weight in kg (for electric forklift trucks only)
- 7 Ballast weight in kg (for electric forklift trucks only)
- 8 Refer to the technical data listed in these operating instructions for more detailed information
- 9 CE labelling
- 10 Nominal drive power in kW
- 11 Battery voltage in V
- 12 Rated capacity in kg

Production number

NOTE

The production number is used to identify the truck. It can be found on the nameplate and must be referred to in all technical questions.

The production number contains the following coded information:

- (1) Production location
- (2) Model
- (3) Year of manufacture
- (4) Sequential number

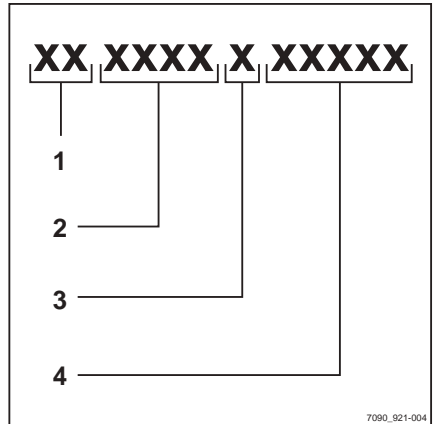

StVZO (Road Traffic Licensing Regulations) information

This label includes information on the weight and load distribution of the truck.

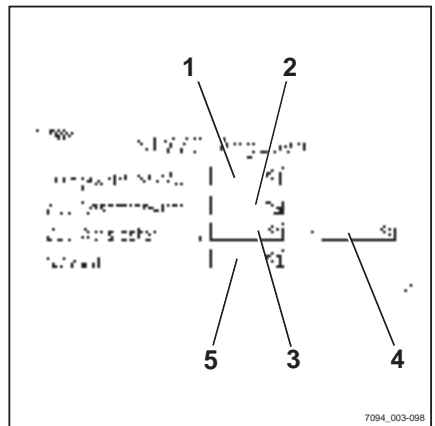

- 1 Tare weight (in kg)
- 2 Permitted total weight (in kg)
- 3 Permitted front axle weight (in kg)
- 4 Permitted rear axle weight (in kg)
- 5 Payload (in kg)

Use of truck

Proper usage

The truck described in these operating instructions is suitable for lifting, transporting and stacking loads.

Use of truck

The truck may only be used for its proper purpose as set out and described in these operating instructions.

If the truck is to be used for purposes other than those specified in the operating instructions, the approval of the manufacturer and, if applicable, the relevant regulatory authorities must be obtained beforehand to prevent hazards.

The maximum load to be lifted is specified on the capacity rating plate (load diagram) and must not be exceeded; see also the chapter entitled "Before picking up a load".

Proper use during towing

This truck is suitable for the occasional towing of trailers and is equipped with a towing device for this purpose. This occasional towing may not exceed 2% of the daily operating time. If the truck is to be used for towing on a more regular basis, the manufacturer should be consulted.

The regulations regarding trailer operation must be observed; see chapter "Trailer operation".

Impermissible use

The operating company or driver, and not the manufacturer, is liable for any hazards caused by improper use.

NOTE

Please observe the definition of the following responsible persons: "operating company" and "driver".

Use for purposes other than those described in these operating instructions is prohibited.



DANGER

There is a risk of fatal injury from falling off the truck while it is moving!

- It is prohibited to carry passengers on the truck.

The truck may not be operated in areas where there is a risk of fire, explosion or corrosion, or in areas that are particularly dusty.

Stacking or unstacking is not permissible on inclined surfaces or ramps.

Place of use

The truck can be used outdoors.

If the truck is equipped with the "particle filter" equipment variant, it fulfils the essential prerequisites for use in ventilated halls. The national regulations for the country of use must be observed.

Operation on public roads is only permitted with the "StVZO" (Road Traffic Licensing Regulations) equipment variant.

If the truck is to be operated on public roads, it must conform to the existing national regulations for the country in which it is being used.

The ground must have an adequate load capacity (concrete, asphalt) and a rough surface. Routes, working areas and aisle widths must conform to the specifications in these operating instructions; see the chapter entitled "Routes".

Driving on upward and downward gradients is permitted provided the specified data and specifications are observed; see the chapter entitled "Routes".

The truck is suitable for use in many different countries, ranging from those situated in the Tropics to those in Nordic regions (temperature range: -20°C to $+40^{\circ}\text{C}$).

This truck is not designed to be operated in cold stores.

The operating company must ensure suitable fire protection for the relevant application in the truck's surroundings. Depending on the application, additional fire protection must be provided on the truck. If in doubt, contact the relevant authorities.

Use of truck



NOTE

Please observe the definition of the following responsible person: "operating company".

DANGER

Risk to health from exhaust gases!

Exhaust gases from internal combustion engines are harmful to your health. In particular, the soot particles contained in the diesel exhaust gas can cause cancer. When the internal combustion engine is left running, there is a risk of poisoning due to the CO, CH and NOx components contained in the exhaust gas.

Modern exhaust gas treatment systems (e.g. catalytic converters, particle filters or comparable systems) can clean exhaust gases in a way that reduces the health hazard and risk of poisoning when operating the truck.

- Observe the national laws and regulations when using trucks with an internal combustion engine in entirely or partially enclosed working areas.
- Always ensure sufficient ventilation.

Using working platforms

WARNING

The use of working platforms is regulated by national law. The use of working platforms is only permitted by virtue of the jurisdiction in the country of use.

- Observe national legislation.
- Before using working platforms, consult the national regulatory authorities.

Information about documentation

Documentation scope

- Original operating instructions
- Original operating instructions for attachments (variant)
- Spare parts list
- VDMA rules for the proper use of industrial trucks
- Depending on the truck equipment, "UPA" operating instructions may also be provided

These operating instructions describe all measures necessary for the safe operation and proper maintenance of the truck in all possible variants available at the time of printing. Special versions to meet customer requirements (UPA) are documented in separate operating instructions. If you have any questions, please contact your authorised service centre.

Enter the production number and year of manufacture from the nameplate in the space provided:

Production number:

Year of manufacture:

Please quote the production number in all technical enquiries.

Each truck comes with a set of operating instructions. These instructions must be stored carefully and must be available to the driver and operating company at all times. The storage location is specified in the chapter entitled "Overviews".

If the operating instructions are lost, the operating company must obtain a replacement from the manufacturer immediately.

The operating instructions are included in the spare parts list and can be reordered as a spare part.

The personnel responsible for operating and maintaining the equipment must be familiar with these operating instructions.

Information about documentation

The operating company must ensure that all users have received, read and understood these operating instructions.



NOTE

Please observe the definition of the following responsible persons: "operating company" and "driver".

Thank you for reading and complying with these operating instructions. If you have any questions or suggestions for improvements, or if you have found any errors, please contact the authorised service centre.

Supplementary documentation

This industrial truck may deviate from the standard equipment or from the variants and be fitted with unplanned equipment (UPA).

This may include the following, for example:

- Special sensors
- Special attachments
- Towing devices
- Customer-specific attachments

In this case, the industrial truck has additional documentation. This may be in the form of an insert or separate operating instructions.

The original operating instructions for this industrial truck are valid for the operation of standard equipment and variants without restriction. The operational and safety information in the original operating instructions continues to be valid in its entirety unless it is specifically countermanded in this additional documentation.

The requirements for the qualification of personnel as well as the time for maintenance may vary. This is defined in the additional documentation.

- If you have any questions, please contact your authorised service centre.

Issue date and topicality of the operating instructions

The issue date of these operating instructions can be found on the title page.

STILL is constantly engaged in the further development of trucks. These operating instructions are subject to change, and any claims based on the information and/or illustrations contained in them cannot be asserted.

Please contact your authorised service centre for technical support relating to your truck.

Copyright and trademark rights

These instructions must not be reproduced, translated or made accessible to third parties—including as excerpts—except with the express written approval of the manufacturer.

Explanation of information symbols used

DANGER

Indicates procedures that must be strictly adhered to in order to prevent the risk of fatalities.

WARNING

Indicates procedures that must be strictly adhered to in order to prevent the risk of injuries.

CAUTION

Indicates procedures that must be strictly adhered to in order to prevent material damage and/or destruction.

NOTE

For technical requirements that require special attention.

Information about documentation

 ENVIRONMENT NOTE

To prevent environmental damage.

List of abbreviations

 NOTE

This list of abbreviations applies to all types of operating instructions. Not all of the abbreviations that are listed here will necessarily appear in these operating instructions.

Abbreviation	Meaning	Explanation
ABE	Display operating unit	
ArbSchG	Arbeitsschutzgesetz	German implementation of EU occupational health and safety directives
BetrSichV	Betriebssicherheitsverordnung	German implementation of the EU working equipment directive
BG	Berufsgenossenschaft	German insurance company for the company and employees
BGG	Berufsgenossenschaftlicher Grundsatz	German principles and test specifications for occupational health and safety
BGR	Berufsgenossenschaftliche Regel	German rules and recommendations for occupational health and safety
DGUV	Berufsgenossenschaftliche Vorschrift	German accident prevention regulations
CE	Communauté Européenne	Confirms conformity with product-specific European directives (CE mark)
CEE	Commission on the Rules for the Approval of the Electrical Equipment	International commission on the rules for the approval of electrical equipment
DC	Direct Current	Direct current
DFÜ	Datenfernübertragung	Remote data transmission
DIN	Deutsches Institut für Normung	German standardisation organisation
EG	European Community	
EN	European standard	
FEM	Fédération Européenne de la Manutention	European Federation of Materials Handling and Storage Equipment
F _{max}	maximum Force	Maximum power
GAA	Gewerbeaufsichtsamt	German authority for monitoring/issuing regulations for worker protection, environmental protection, and consumer protection

Abbreviation	Meaning	Explanation
GPRS	General Packet Radio Service	Transfer of data packets in wireless networks
ID no.	ID number	
ISO	International Organization for Standardization	International standardisation organisation
LAN	Local Area Network	Local area network
K _{pA}	Uncertainty of measurement of sound pressure levels	
LED	Light Emitting Diode	Light emitting diode
L _p	Sound pressure level at the workplace	
L _{pAZ}	Average continuous sound pressure level in the driver's compartment	
LSP	Load centre of gravity	Distance of the centre of gravity of the load from the front face of the fork backs
MAK	Maximum workplace concentration	Maximum permissible air concentrations of a substance at the workplace
Max.	Maximum	Highest value of an amount
Min.	Minimum	Lowest value of an amount
PIN	Personal Identification Number	Personal identification number
PPE	Personal protective equipment	
SE	Super-Elastic	Superelastic tyres (solid rubber tyres)
SIT	Snap-In Tyre	Tyres for simplified assembly, without loose rim parts
StVZO	Straßenverkehrs-Zulassungs-Ordnung	German regulations for approval of vehicles on public roads
TRGS	Technische Regel für Gefahrstoffe	Ordinance on hazardous materials applicable in the Federal Republic of Germany
VDE	Verband der Elektrotechnik Elektronik Informationstechnik	German technical/scientific association
VDI	Verein Deutscher Ingenieure	German technical/scientific association
VDMA	Verband Deutscher Maschinen- und Anlagenbau e.V.	German Mechanical Engineering Industry Association
WLAN	Wireless LAN	Wireless local area network

Information about documentation

Definition of directions

The directions "forwards" (1), "backwards" (3), "right" (2) and "left" (4) refer to the installation position of the parts as seen from the driver's compartment; the load is to the front.

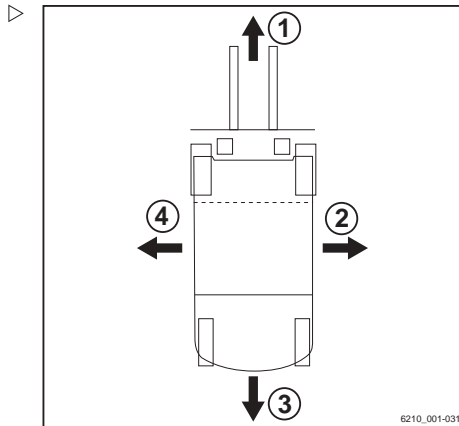
**Schematic views****View of functions and operations**

This documentation explains the (usually sequential) chain of certain functions or operations. Schematic diagrams of a counterbalance truck are used to illustrate these procedures.

 NOTE

These schematic diagrams are not representative of the structural state of the documented truck. The diagrams are used solely for the purpose of clarifying procedures.

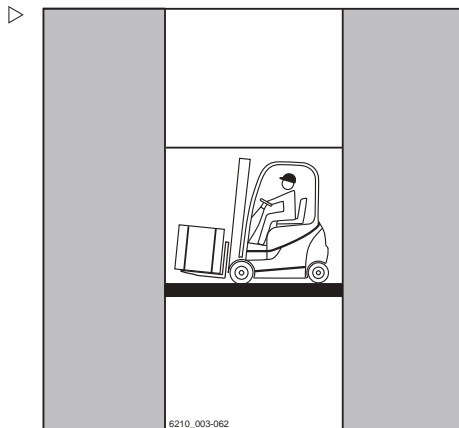

View of the display operating unit

NOTE

Views of operating statuses and values in the display of the display operating unit are examples and partly dependent on the truck equipment. As a result, the displays shown of the actual operating statuses and values can vary. Information that is not relevant for descriptions is not shown.

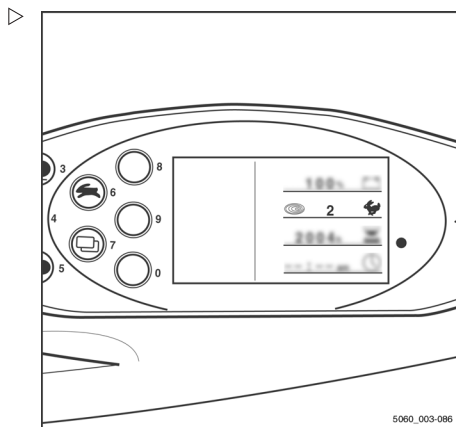

Environmental considerations

Environmental considerations

Packaging

During delivery of the truck, certain parts are packaged to provide protection during transport. This packaging must be removed completely prior to initial start-up.



ENVIRONMENT NOTE

The packaging material must be disposed of properly after delivery of the truck.

Disposal of components and batteries

The truck is composed of different materials. If components or batteries need to be replaced and disposed of, they must be:

- disposed of,
- treated or
- recycled in accordance with regional and national regulations.



NOTE

The documentation provided by the battery manufacturer must be observed when disposing of batteries.



ENVIRONMENT NOTE

We recommend working with a waste management company for disposal purposes.

2

Safety

Definition of responsible persons

Definition of responsible persons

Operating company

The operating company is the natural or legal person or group who operates the truck or on whose authority the truck is used.

The operating company must ensure that the truck is only used for its proper purpose and in compliance with the safety regulations set out in these operating instructions.

The operating company must ensure that all users read and understand the safety information.

The operating company is responsible for the scheduling and correct performance of regular safety checks.

We recommend that the national performance specifications are adhered to.

Specialist

A qualified person is defined as a service engineer or a person who fulfils the following requirements:

- A completed vocational qualification that demonstrably proves their professional expertise. This proof should consist of a vocational qualification or a similar document.
- Professional experience indicating that the qualified person has gained practical experience of industrial trucks over a proven period during their career. During this time, this person has become familiar with a wide range of symptoms that require checks to be carried out, such as based on the results of a hazard assessment or a daily inspection.
- Recent professional involvement in the field of the industrial truck test in question and an appropriate further qualification are essential. The qualified person must have experience of carrying out the test in question or of carrying out similar tests. Moreover, this person must be aware of the latest technological developments.

regarding the industrial truck to be tested and the risk being assessed

Drivers

This truck may only be driven by suitable persons who are at least 18 years of age, have been trained in driving, have demonstrated their skills in driving and handling loads to the operating company or an authorised representative, and have been specifically instructed to drive the truck. Specific knowledge of the truck to be operated is also required.

The training requirements under §3 of the Health and Safety at Work Act and §9 of the plant safety regulations are deemed to have been satisfied if the driver has been trained in accordance with BGG (General Employers' Liability Insurance Association Act) 925. Observe the national regulations for your country.

Driver rights, duties and rules of behaviour

The driver must be trained in his rights and duties.

The driver must be granted the required rights.

The driver must wear protective equipment (protection suit, safety footwear, safety helmet, industrial goggles and gloves) that is appropriate for the conditions, the job and the load to be lifted. Solid footwear should be worn to ensure safe driving and braking.

The driver must be familiar with the operating instructions and have access to them at all times.

The driver must:

- have read and understood the operating manual
- have familiarised himself with safe operation of the truck
- be physically and mentally able to drive the truck safely

Definition of responsible persons

DANGER

The use of drugs, alcohol or medications that affect reactions impair the ability to drive the truck!

Individuals under the influence of the aforementioned substances are not permitted to perform work of any kind on or with the truck.

Prohibition of use by unauthorised persons

The driver is responsible for the truck during working hours. He must not allow unauthorised persons to operate the truck.

When leaving the truck, the driver must secure it against unauthorised use, e.g. by pulling out the key.

Essentials for safe operation

Insurance cover on company premises

In many cases, company premises are restricted public traffic areas.



NOTE

The business liability insurance should be reviewed to ensure that, in the event of any damage caused in restricted public traffic areas, there is insurance cover for the truck in respect of third parties.

Changes and retrofitting

If the truck is used for work that is not listed in the guidelines or in these instructions and has to be converted or retrofitted accordingly, you must note that any change to its structural state can affect the handling and stability of the truck, which in turn can lead to accidents.

You should therefore contact your service centre beforehand.

Changes that will adversely affect stability, load capacity and safety systems, among other things, must not be made without the manufacturer's approval.

The truck may only be converted with written approval from the manufacturer. Approval from the responsible authority must be obtained if necessary.

Changes to the brakes, steering, control elements, circumferential view, equipment variants and attachments must also not be made without the prior written approval of the manufacturer.

We warn against installing and using restraint systems not approved by the manufacturer.

Essentials for safe operation

DANGER

Risk of injury!

Even when using an approved restraint system, there is some residual risk that the driver might be injured if the truck tips over. This risk of injury can be reduced through the combined use of the restraint system and the seat belt. In addition, the seat belt protects against the consequences of rear-end collisions and falling off a ramp.

- Use the seat belt too.
-

When carrying out welding work on the truck, it is essential that the battery and all connections to the electronic control cards are disconnected. Contact your service centre.

DANGER

If the truck is not equipped with an overhead guard, there is a risk to the driver's life, as he may be struck by a load falling from a lift height of 1800 mm or greater.

Operation of the forklift truck without an overhead guard is prohibited with a lift height greater than 1800 mm.

- For lift heights of 1800 mm and greater, only use trucks with an overhead guard
-

In the event that the manufacturer goes into liquidation and the company is not taken over by another legal person, the operating company can make changes to the truck.

To do so, the operating company must fulfil the following prerequisites:

Construction documents, test documents and assembly instructions associated with the change must be archived and remain accessible at all times.

Check that the capacity rating plate, decal information, hazard warnings and the operating instructions are consistent with regard to the changes and modify if necessary.

The change must be designed, checked and implemented by a design office that specialises in industrial trucks in accordance with the standards and directives valid at the time the changes are made.

Decal information with the following data must be permanently affixed to the truck so it is clearly visible:

- Type of change
- Date of change
- Name and address of the company implementing the change.

Changes to the overhead guard and roof loads

DANGER

In the event of the overhead guard failing due to a falling load or the truck tipping over, there are potentially fatal consequences for the driver. There is a risk to life!

Welding and drilling on the overhead guard changes the material characteristics and the structural design of the overhead guard. Excessive forces caused by falling loads or the truck tipping over may result in buckling of the modified overhead guard and no protection for the driver.

- Do not perform welding on the overhead guard.
- Do not perform drilling on the overhead guard.

CAUTION

Heavy roof loads damage the overhead guard!

To ensure the stability of the overhead guard at all times, a roof load may only be mounted on the overhead guard if the structural design has been tested and the manufacturer has given approval.

- Seek advice from the authorised service centre for the mounting of roof loads.

Warning regarding non-original parts

Original parts, attachments and accessories are specially designed for this truck. We specifically draw your attention to the fact that parts, attachments and accessories supplied by other companies have not been tested and approved by STILL.

Essentials for safe operation

⚠ CAUTION

Installation and/or use of such products may therefore have a negative impact on the design features of the truck and thus impair active and/or passive driving safety.

We recommend that you obtain approval from the manufacturer and, if necessary, from the relevant regulatory authorities before installing such parts. The manufacturer accepts no liability for any damage caused by the use of non-original parts and accessories without approval.

Damage, defects and misuse of safety systems

Damage or other defects on the truck or attachment must be reported to the supervisor or responsible fleet manager immediately so that they can have the defect rectified.

Trucks and attachments that are not functional or safe to drive may not be used until they have been properly repaired.

Do not remove or deactivate safety systems and switches.

Fixed set values may only be changed with the approval of the manufacturer.

Work on the electrical system (e.g. connecting a radio, additional headlights etc.) is only permitted with the manufacturer's written approval. All electrical system interventions must be documented.

Even if they are removable, roof panels may not be removed, as they are designed to protect against small falling objects.

Tyres

⚠ DANGER

Risk to stability!

Failure to observe the following information and instructions can lead to a loss of stability. The truck may tip over, risk of accident!

The following factors can lead to a loss of stability and are therefore **prohibited**:

- Different tyres on the same axle, e.g. pneumatic tyres and superelastic tyres
- Tyres not approved by the manufacturer
- Excessive tyre wear
- Tyres of inferior quality
- Changing rim wheel parts
- Combining rim wheel parts from different manufacturers

The following rules must be observed to ensure stability:

- Only use tyres with equal and permitted levels of wear on the same axle
- Only use wheels and tyres of the same type on the same axle, e.g. only superelastic tyres
- Only use wheels and tyres approved by the manufacturer
- Only use high-quality products

Wheels and tyres approved by the manufacturer can be found on the spare parts list. If other wheels or tyres are to be used, authorisation from the manufacturer must be obtained beforehand.

- Contact the authorised service centre on this matter.

When changing wheels or tyres, always ensure that this does not cause the truck to tilt to one side (e.g. always replace right-hand and left-hand wheels at the same time). Changes must only be made following consultation with the manufacturer.

If the type of tyre used on an axle is changed, for example from superelastic tyres to pneumatic tyres, the load diagram must be changed accordingly.

- Contact the authorised service centre on this matter.

Essentials for safe operation

Medical equipment

⚠ WARNING

Electromagnetic interference may occur on medical devices!

Only use equipment that is sufficiently protected against electromagnetic interference.

Medical equipment, such as pacemakers or hearing aids, may not work properly when the truck is in operation.

- Ask your doctor or the manufacturer of the medical equipment to confirm that the medical equipment is sufficiently protected against electromagnetic interference.

Exercise caution when handling gas springs and accumulators

⚠ WARNING

Gas springs are under high pressure. Improper removal results in an elevated risk of injury.

For ease of operation, various functions on the truck can be supported by gas springs. Gas springs are complex components that are subject to high internal pressures (up to 300 bar). They may under no circumstances be opened unless instructed to do so, and may be installed only when not under pressure. If required, the authorised service centre will depressurise the gas spring in accordance with the regulations before removal. Gas springs must be depressurised before recycling.

- Avoid damage, lateral forces, buckling, temperatures over 80°C and heavy contamination.
- Damaged or defective gas springs must be changed immediately.
- Contact the authorised service centre.

⚠ WARNING

Accumulators are under high pressure. Improper installation of an accumulator results in an elevated risk of injury.

Before starting work on the accumulator it must be depressurised.

- Contact the authorised service centre.

Length of the fork arms

DANGER

Risk of accident due to the incorrect selection of fork arms!

- The fork arms must match the depth of the load.

If the fork arms are too short, the load may fall off the arms after it has been picked up. In addition, be aware that the load centre of gravity may shift as a result of dynamic forces, such as braking. A load that is otherwise resting safely on the fork arms may move forwards and fall.

If the fork arms are too long, they can catch on loading units behind the load that is to be picked up. These other loading units then fall over when the load is raised.

- For help with selecting the correct fork arms, contact the authorised service centre.

Residual risk

Residual risk

Residual dangers, residual risks

Despite careful working and compliance with standards and regulations, the occurrence of other risks when using the truck cannot be entirely excluded.

The truck and all other system components comply with current safety requirements. Nevertheless, even when the truck is used for its proper purpose and all instructions are followed, some residual risk cannot be excluded.

Even beyond the narrow danger areas of the truck itself, a residual risk cannot be excluded. Persons in this area around the truck must exercise a heightened degree of awareness, so that they can react immediately in the event of any malfunction, incident or breakdown etc.

WARNING

All persons that are in the vicinity of the truck must be instructed regarding these risks that arise through use of the truck.

In addition, we draw attention to the safety regulations in these operating instructions.

Risks can include:

- Escape of consumables due to leakages, rupture of lines and containers etc.
- Risk of accident when driving over difficult ground such as gradients, smooth or irregular surfaces, or with poor visibility etc.
- Falling, tripping etc. when moving on the truck, especially in wet weather, with leaking consumables or on icy surfaces
- Fire and explosion risks due to batteries and electrical voltages
- Human error resulting from failure to observe the safety regulations,
- Unrepaired damage or defective and worn components,
- Insufficient maintenance and testing
- Use of incorrect consumables
- Exceeding test intervals

The manufacturer is not held responsible for accidents involving the truck caused by the failure of the operating company to comply with these regulations either intentionally or carelessly.

Stability

The stability of the truck has been tested to the latest technological standards and is guaranteed provided that the truck is used properly and according to its intended purpose. These standards only take into account the dynamic and static tipping forces that can arise during specified use in accordance with the operating rules and intended purpose. However, the danger of exceeding the moment of tilt due to improper use or incorrect operation and losing stability can never be excluded.

The loss of stability can be avoided or minimised by the following actions:

- Always secure the load against slipping, e.g. by lashing.
- Always transport unstable loads in suitable containers.
- Always drive slowly when cornering.
- Drive with the load lowered.
- Even with sideshifts, align the load as centrally as possible with the truck and transport in this position.
- Avoid turning and diagonally driving across slopes or gradients.
- Never have the load facing downhill when travelling on slopes or gradients.
- Pick up only loads of the approved width.
- Always take great care when transporting suspended loads.
- Do not drive over ramp edges or steps.

Special risks associated with using the truck and attachments

Approval from the manufacturer and attachment manufacturer must be obtained each

Residual risk

time the truck is used in a manner that falls outside the scope of normal use, and in cases where the driver is not certain that he can use the truck correctly and without the risk of accidents.

Residual risk

Overview of hazards and counter-measures

NOTE

This table is intended to help evaluate the hazards in your facility and applies to all drive types. It does not claim to be complete.

- Observe the national regulations for the country in which the truck is being used.

Hazard	Measure	Check note ✓ Complete - Not applicable	Notes
Truck equipment does not comply with local regulations	Test	○	If in doubt, consult competent factory inspectorate or employers' liability insurance association
Lack of skills and qualification of driver	Driver training (sit-on and stand-on)	○	BGG 925 VDI 3313 driver permit
Usage by unauthorised persons	Access with key only for authorised persons	○	
Truck not in a safe condition	Recurrent testing and rectification of defects	○	German Ordinance on Industrial Safety and Health (BetrSichV)
Risk of falling when using working platforms	Compliance with national regulations (different national laws)	○	German Ordinance on Industrial Safety and Health (BetrSichV) and employer's liability insurance associations
Impaired visibility due to load	Resource planning	○	German Ordinance on Industrial Safety and Health (BetrSichV)
Contamination of respiratory air	Assessment of diesel exhaust gases	○	Technical Regulations for Hazardous Substances (TRGS) 554 and the German Ordinance on Industrial Safety and Health (BetrSichV)
	Assessment of LPG exhaust gases	○	German threshold limit values list (MAK-Liste) and the German Ordinance on Industrial Safety and Health (BetrSichV)

Hazard	Measure	Check note √ Complete - Not applicable	Notes
Impermissible usage (improper usage)	Issuing of operating instructions	○	German Ordinance on Industrial Safety and Health (BetrSichV) and German Health and labour protection law (ArbSchG)
	Written notice of instruction to driver	○	German Ordinance on Industrial Safety and Health (BetrSichV) and German Health and labour protection law (ArbSchG)
	Note the German Ordinance on Industrial Safety and Health (BetrSichV), the operating instructions and the German Engineering Federation (VDMA) rules	○	
When fuelling			
a) Diesel	Note the German Ordinance on Industrial Safety and Health (BetrSichV), the operating instructions and the German Engineering Federation (VDMA) rules	○	
b) LPG	Note German Social Accident Insurance (DGUV) regulation D34, the operating instructions and the German Engineering Federation (VDMA) rules	○	

Residual risk

Hazard	Measure	Check note ✓ Complete - Not applicable	Notes
When charging the traction battery	Note the German Ordinance on Industrial Safety and Health (BetrSichV), the operating instructions and the German Engineering Federation (VDMA) rules	○	Association for Electrical, Electronic and Information Technologies (VDE) regulation 0510: In particular - Ensure adequate ventilation - Insulation value within the permissible range
When using battery chargers	Note the German Ordinance on Industrial Safety and Health (BetrSichV), employers' liability insurance association regulation 104 and the operating instructions	○	German Ordinance on Industrial Safety and Health (BetrSichV) and employers' liability insurance association regulation 104
When parking LPG trucks	Note the German Ordinance on Industrial Safety and Health (BetrSichV), employers' liability insurance association regulation 104 and the operating instructions	○	German Ordinance on Industrial Safety and Health (BetrSichV) and employers' liability insurance association regulation 104
With driverless transport systems			
Roadway quality inadequate	Clean/clear driveways	○	German Ordinance on Industrial Safety and Health (BetrSichV)
Load carrier incorrect/slipped	Reattach load to pallet	○	German Ordinance on Industrial Safety and Health (BetrSichV)
Drive behaviour unpredictable	Employee training	○	German Ordinance on Industrial Safety and Health (BetrSichV)
Driveways blocked	Mark driveways Keep driveways clear	○	German Ordinance on Industrial Safety and Health (BetrSichV)
Driveways intersect	Announce right-of-way rule	○	German Ordinance on Industrial Safety and Health (BetrSichV)
No person detection during depositing and retrieval	Employee training	○	German Ordinance on Industrial Safety and Health (BetrSichV)

Danger to employees

According to the German Ordinance on Industrial Safety and Health (BetrSichV) and labour protection law (ArbSchG), the operating company must determine and assess hazards during operation, and establish the labour protection measures required for employees (BetrSichVO). The operating company must therefore draw up appropriate operating instructions (§ 6 ArbSchG) and make them available to the driver. A responsible person must be appointed.



NOTE

Please observe the definition of the following responsible persons: "operating company" and "driver".

The construction and equipment of the truck correspond to the Machinery Directive 2006/42/EC and are therefore marked with CE labelling. These elements are therefore not included in the hazard assessment. Attachments possess their own CE labelling and likewise are not included for that reason. The operating company must, however, select the type and equipment of the trucks so as to comply with the local provisions for deployment.

The result must be documented (§ 6 ArbSchG). In the case of truck applications involving similar hazard situations, the results may be summarised. This overview (see chapter "Overview of hazards and countermeasures") provides help on complying with this regulation. The overview specifies the main hazards that are the most frequent cause of accidents in the event of non-compliance. If other major operational hazards are involved, they must also be taken into consideration.

The conditions of use for trucks are broadly similar in many plants, so the hazards can be summarised in one overview. Observe the information provided by the relevant employers' liability insurance association on this subject.

Safety inspections

Safety inspections

Regular safety inspection of the truck ▷

Safety inspection based on time and extraordinary incidents

The operating company must ensure that the truck is checked by a specialist at least once a year or after particular incidents.

As part of this inspection, a complete check of the technical condition of the truck must be performed with regard to accident safety. In addition, the truck must be thoroughly checked for damage that could potentially have been caused by improper use. A test log must be created. The results from the inspection must be retained until a further two inspections have been carried out.

The inspection date is indicated by an adhesive label on the truck.

- Arrange for the service centre to perform periodic safety inspections on the truck.
- Observe guidelines for checks carried out on the truck in accordance with FEM 4.004.

The operator is responsible for ensuring any defects are remedied without delay.

- Contact your service centre.



NOTE

Observe the national regulations for your country!

Checking the diesel engine emissions

- Check the diesel engine emissions annually to TRGS 554.

The exhaust-gas check is to be carried out by a specialist (see ⇒ Chapter "Definition of responsible persons", P. 24) and must be recorded in writing.

- Contact your STILL service centre.



 **NOTE**

Observe the national regulations for your country!

Trucks with particle filters

Trucks with particle filters (variant) may be operated in completely or partially enclosed working areas.

 **DANGER**

Risk to health from exhaust gases!

Exhaust gases from internal combustion engines are harmful to your health. In particular, the soot particles contained in the diesel exhaust gas can cause cancer.

When the internal combustion engine is running, there is a risk of poisoning from the CO, CH and NOx components contained in the exhaust gas.

Modern exhaust gas treatment systems (e.g. catalytic converters, particle filters or comparable systems) can clean exhaust gases in a way that reduces the health hazard and risk of poisoning when operating the truck.

- Observe the national laws and regulations when using trucks with an internal combustion engine in entirely or partially enclosed working areas.
- Always ensure sufficient ventilation.

The operating company must ensure that the following requirements are met:

- Usage must be reported to the responsible occupational health and safety authorities
- Operating instructions must be displayed in the working areas
- Danger areas should be confined and indicated by appropriate warning and safety signs
- Employees must be made aware of dangers and protective measures
- The particle filter must be checked and serviced every 12 months or after every 1000 operating hours. The exhaust-gas check must be carried out by a competent person and must be recorded in writing

Safety inspections

NOTE

Please observe the definition of the following responsible persons: "operating company" and "competent person".

NOTE

Observe the TRGS 554 regulations and national regulations of the country in which the truck is being used.

Insulation testing

The truck insulation must have sufficient insulation resistance. For this reason, insulation testing in accordance with DIN EN 1175 and DIN 43539, VDE 0117 and VDE 0510 must be conducted at least once every year.

NOTE

Contact your service centre to arrange for an insulation test.

Measuring the insulation resistance of the electrical system

NOTE

Nominal battery voltage < test voltage < 500 V.

- Ensure that all voltage sources have been disconnected from the circuit to be tested.
- Measure the insulation resistance with a suitable measuring device.

The insulation resistance can be considered sufficient if it measures at least 1000 Ω/V for nominal battery voltage against ground.

- Contact the authorised service centre.

Safety regulations when handling consumables

Permissible consumables

DANGER

Failure to observe the safety regulations relating to consumables may result in a risk of injury, death or damage to the environment.

- Observe the safety regulations when handling such materials.

Refer to the maintenance data table for the permissible substances that are necessary for operation (see ⇒ Chapter "Maintenance data table", P. 5-314).

Oils



DANGER

Oils are flammable!

- Follow the statutory regulations.
- Do not allow oils to come into contact with hot engine parts.
- No smoking, fires or naked flames!



DANGER

Oils are toxic!

- Avoid contact and consumption.
- If vapour or fumes are inhaled, move to fresh air immediately.
- In the event of contact with the eyes, rinse thoroughly (for at least 10 minutes) with water and then consult an eye specialist.
- If swallowed, do not induce vomiting. Seek immediate medical attention.

Safety regulations when handling consumables



⚠ WARNING

Prolonged intensive contact with the skin can result in dryness and irritate the skin!

- Avoid contact and consumption.
- Wear protective gloves.
- After any contact, wash the skin with soap and water, and then apply a skin care product.
- Immediately change soaked clothing and shoes.

⚠ WARNING

There is a risk of slipping on spilled oil, particularly when combined with water!

- Spilt oil should be removed immediately with oil-binding agents and disposed of according to the regulations.



ENVIRONMENT NOTE

Oil is a water-polluting substance!

- *Always store oil in containers that comply with the applicable regulations.*
- *Avoid spilling oils.*
- *Spilt oil should be removed immediately with oil-binding agents and disposed of according to the regulations.*
- *Dispose of old oils according to the regulations.*

Hydraulic fluid



⚠ WARNING

These fluids are pressurised during operation of the truck and are hazardous to your health.

- Do not spill the fluids.
- Follow the statutory regulations.
- Do not allow the fluids to come into contact with hot engine parts.

**⚠️ WARNING**

These fluids are pressurised during operation of the truck and are hazardous to your health.

- Do not allow the fluids to come into contact with the skin.
- Avoid inhaling spray.
- Penetration of pressurised fluids into the skin is particularly dangerous if these fluids escape at high pressure due to leaks in the hydraulic system. In case of such injury, immediate medical assistance is required.
- To avoid injury, use appropriate personal protective equipment (e.g. protective gloves, industrial goggles, skin protection and skin care products).

**ENVIRONMENT NOTE**

Hydraulic fluid is a water-polluting substance.

- *Always store hydraulic fluid in containers that comply with regulations*
- *Avoid spills*
- *Spilt hydraulic fluid should be removed immediately with oil-binding agents and disposed of according to the regulations*
- *Dispose of old hydraulic fluid according to the regulations*

Battery acid**⚠️ WARNING**

Battery acid contains dissolved sulphuric acid. This is toxic.

- Avoid touching or swallowing the battery acid at all costs.
- In case of injury, seek medical advice immediately.

Safety regulations when handling consumables



⚠ WARNING

- Battery acid contains dissolved sulphuric acid. This is corrosive.
- When working with battery acid, use appropriate PSA (rubber gloves, apron, protection goggles).
 - When working with battery acid, never wear a watch or jewellery.
 - Do not allow any acid to get onto clothing or skin or into the eyes. If this does happen, rinse immediately with plenty of clean water.
 - In case of injury, seek medical advice immediately.
 - Immediately rinse away spilt battery acid with plenty of water.
 - Follow the statutory regulations.



ENVIRONMENT NOTE

- Dispose of used battery acid in line with the applicable regulations.

Diesel fuel



⚠ WARNING

- Diesel fuel is combustible.
- Observe statutory regulations.
 - Do not allow diesel fuel to come into contact with hot engine components.

Do not smoke!



⚠ WARNING

- Diesel fuel is toxic!
- Avoid contact and swallowing.
 - If vapour or fumes are inhaled, administer fresh air immediately.
 - After contact with the eyes, rinse thoroughly (for at least 10 minutes) with water and then consult an eye specialist.
 - If swallowed, do not induce vomiting. Seek immediate medical attention.

**⚠ WARNING**

Prolonged intensive contact with the skin can result in loss of skin oils and can irritate the skin!

- Avoid contact and swallowing.
 - Wear protective gloves.
 - After any contact, wash the skin with soap and water, and then apply a skin care product.
 - Immediately change soaked clothing and shoes.
-

⚠ WARNING

Risk of slipping due to spilled diesel fuel, particularly in combination with water.

- Immediately collect spilled diesel fuel using an oil-binding agent and dispose of it in accordance with regulations.
-

**ENVIRONMENT NOTE**

Diesel fuel is a water-polluting substance!

- Always store in regulation containers.
- Avoid spilling diesel fuel.
- Immediately collect spilled diesel fuel using an oil-binding agent and dispose of it in accordance with regulations.

Safety regulations when handling consumables

Coolant and cooling fluid



WARNING

Coolant and cooling fluid can be hazardous to your health and the environment!

Coolants are chemical corrosion inhibitors and cooling system protecting agents such as Glysantin. Cooling fluid is an appropriate mixture of water and coolant. Coolant in both concentrated and dilute form can be hazardous to your health if swallowed, or hazardous to the environment if spilled.

- Store coolant and cooling fluid only in their original containers and do not spill them.
- Never store coolant or cooling fluid in empty food containers, bottles or other containers.
- Observe the national regulations for the country of use.



ENVIRONMENT NOTE

- Soak up any spilt coolant or cooling fluid immediately using an oil binding agent and dispose of it in accordance with the national regulations for the country of use.
- Dispose of old coolant or cooling fluid in accordance with the national regulations for the country of use.

Disposal of consumables



ENVIRONMENT NOTE

Materials that accumulate during repair, maintenance and cleaning must be collected properly and disposed of in accordance with the national regulations for the country in which the truck is being used. Work must only be carried out in areas designated for that purpose. Care must be taken to minimise any environmental pollution.

- Soak up any spilt fluids such as hydraulic oil or gearbox oil immediately using an oil-binding agent.

- Neutralise any spilt battery acid immediately.
- Always observe national regulations concerning the disposal of used oil.

Emissions

Emissions

The values specified apply to a standard truck (compare the specifications in the "Technical data" chapter). Different tyres, lift masts, additional units etc. may produce different values.

Noise emissions

The values were determined based on measuring procedures from the standard EN 12053 "Safety of industrial trucks. Test methods for measuring noise emissions", based on EN 12001, EN ISO 3744 and the requirements of EN ISO 4871.

This machine emits the following sound pressure level:

Continuous sound pressure level in the driver's compartment

L _{pAZ}	Measurement uncertainty K _{pA}
< 74.0 dB(A)	4 dB(A)

The values were determined in the test cycle on an identical machine from the weighted values for operating conditions and idling.

Time proportions:

- Lifting 18%
- Idling 58%
- Driving 24%

However, the indicated noise levels at the truck cannot be used to determine the noise emissions at workplaces according to the most recent version of **Directive 2003/10/EC** (daily personal noise pollution). If necessary, these noise emissions should be determined by the operating company directly at the workplace under the actual conditions there (additional noise sources, special application conditions, sound reflections).



NOTE

Please note the definition of "operating company" in the sense of responsible persons!

Vibrations

The vibrations of the machine have been determined on an identical machine in accordance with the standards DIN EN 13059 "Safety of industrial trucks - Test methods for measuring vibration" and DIN EN 12096 "Mechanical vibration - Declaration and verification of vibration emission values".

Frequency-weighted effective value of acceleration on the seat

MSG 65 driver's seat	Measurement uncertainty
$< 0.71 \text{ m/s}^2$	0.177 m/s^2

Tests have indicated that the amplitude of the hand and arm vibrations on the steering wheel or on the operating devices in the truck is less than 2.5 m/s^2 . There are therefore no measurement guidelines for these measurements.

The personal vibration load on the driver over a working day must be determined by the operating company at the actual place of use in accordance with **Directive 2002/44/EC**, in order to consider all additional influences, such as driving route, intensity of use etc.

NOTE

Please note the definition of "operating company" in the sense of responsible persons!

Emissions

Exhaust gases

DANGER

Risk to health from exhaust gases!

Exhaust gases from internal combustion engines are harmful to your health. In particular, the soot particles contained in the diesel exhaust gas can cause cancer.

When the internal combustion engine is running, there is a risk of poisoning from the CO, CH and NOx components contained in the exhaust gas.

Modern exhaust gas treatment systems (e.g. catalytic converters, particle filters or comparable systems) can clean exhaust gases in a way that reduces the health hazard and risk of poisoning when operating the truck.

- Observe the national regulations for the country of use when using trucks with an internal combustion engine in entirely or partially enclosed working areas.
 - Always ensure sufficient ventilation.
-

Heat



DANGER

Risk of burns due to hot exhaust gases!

Exhaust gases or components that carry exhaust gases (e.g. exhaust pipes) can become so hot that direct body contact can cause burns to the skin and materials that are too close can be burned or singed.

- Do not grasp or touch hot exhaust pipes.
 - Keep combustible materials away from the exhaust pipe.
 - In the event of burns, seek first aid immediately.
 - If materials are burning, take fire protection measures immediately.
-

3

Overviews

General view

General view

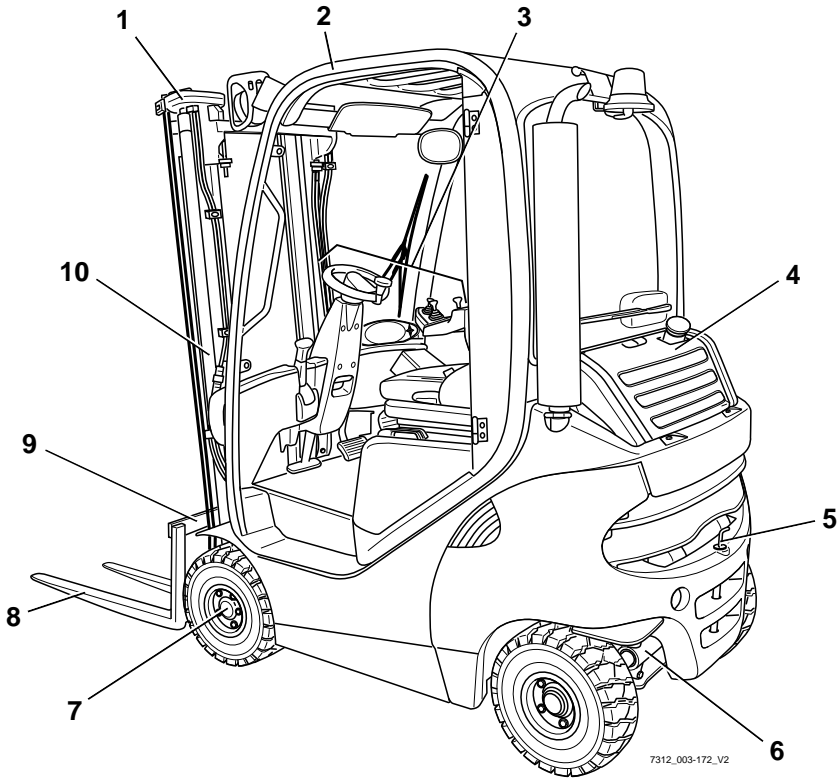

7312_003-172_V2

- | | | | |
|---|----------------------|----|----------------|
| 1 | Lift mast | 6 | Steering axle |
| 2 | Overhead guard | 7 | Drive axle |
| 3 | Driver's compartment | 8 | Fork arms |
| 4 | Fuel tank | 9 | Fork carriage |
| 5 | Towing device | 10 | Lift cylinders |

Driver's compartment

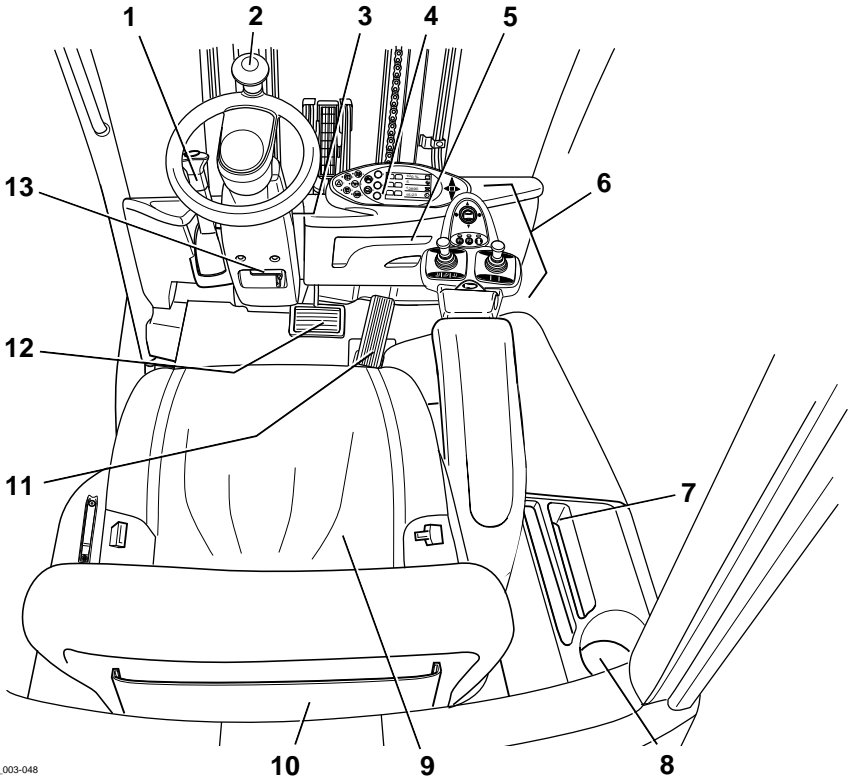

7314_003-048

- | | | | |
|---|--|----|---|
| 1 | Parking brake lever | 8 | Cup holder for max. 0.5-l bottles |
| 2 | Steering wheel | 9 | Driver's seat |
| 3 | Key switch | 10 | Compartment and storage location for operating instructions |
| 4 | Display and operating unit | 11 | Accelerator pedal |
| 5 | Document holder | 12 | Brake pedal |
| 6 | Operating devices for hydraulic and traction functions | 13 | Steering column adjustment lever |
| 7 | Compartment (variant) | | |

i NOTE

The truck equipment may differ from the equipment shown.

Operating and display elements

Operating and display elements

Display and operating unit

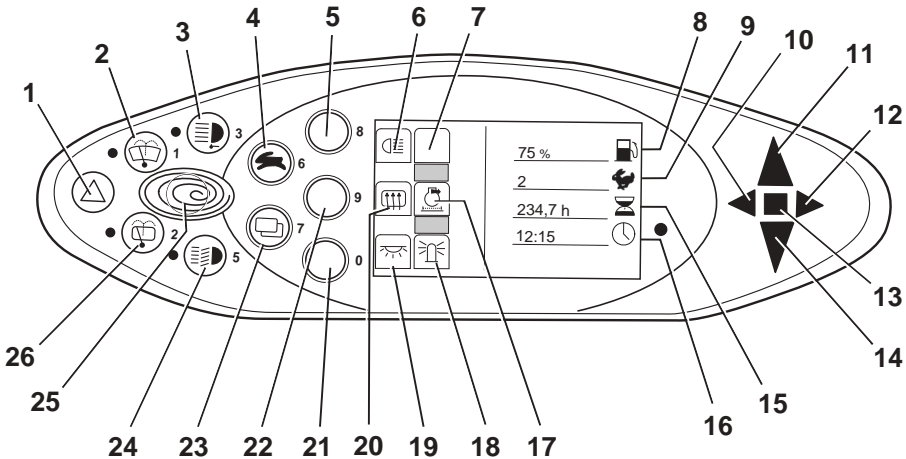

7314_003-043

- | | | | |
|----|-------------------------------------|----|---|
| 1 | Hazard warning system button | 15 | Operating hours display |
| 2 | Front windscreen wiper button | 16 | Time display (digital) |
| 3 | Working spotlight button | 17 | Particle filter display |
| 4 | Drive programme selector button | 18 | Rotating beacon display |
| 5 | Lighting button | 19 | Interior lighting display |
| 6 | Lighting symbol | 20 | Rear window heating display |
| 7 | Not assigned | 21 | Interior lighting/rotating beacon button |
| 8 | Fuel level display (percentage) | 22 | Rear window heating/particle filter regeneration button |
| 9 | Drive programme display (numerical) | 23 | Menu change button |
| 10 | Left turn indicator display | 24 | Lighting button |
| 11 | Forward travel indicator | 25 | Blue-Q button |
| 12 | Right turn indicator display | 26 | Rear window wiper button |
| 13 | Malfunction display | | |
| 14 | Reverse travel indicator | | |

 NOTE

Buttons (5, 21, 22) and the accompanying display elements (6, 7, 17, 18, 19, 20) are assigned according to the equipment variants in use.

The assignment shown here is an example and may differ from the assignment actually programmed on the truck. Buttons may be assigned multiple functions that are called up according to the menu navigation. For further information, see the "Operating the display and operating unit" chapter.

- If you have any questions, please contact your authorised service centre.

Operating devices for hydraulic and driving functions

Different versions of the operating devices are available for operating the truck's hydraulic and traction functions.

The truck can be equipped with the following operating devices:

- **Double mini-lever**
- **Triple mini-lever**
- **Quadruple mini-lever**
- **Joystick 4Plus**
- **Fingertip switch**
- **Mini-console**

Operating and display elements

Double mini-lever

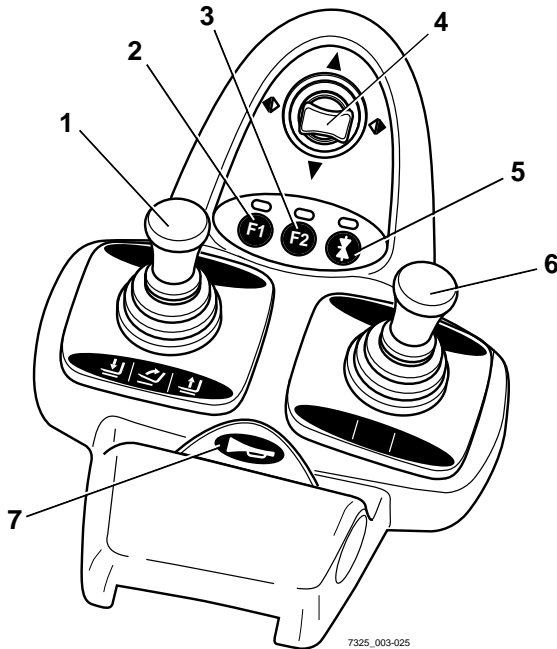

- | | | | |
|---|--|---|-----------------------------|
| 1 | "Lift mast" 360° lever | 5 | Function key "5th function" |
| 2 | Function key F1 | 6 | "Attachments" cross lever |
| 3 | Function key F2 | 7 | Signal horn button |
| 4 | "Drive direction/turn indicator" cross lever | | |

i NOTE

Depending on the equipment, various electric attachment parts can be controlled via function keys (2) and (3). Changes must only be made by the STILL service centre.

Three-way mini-lever

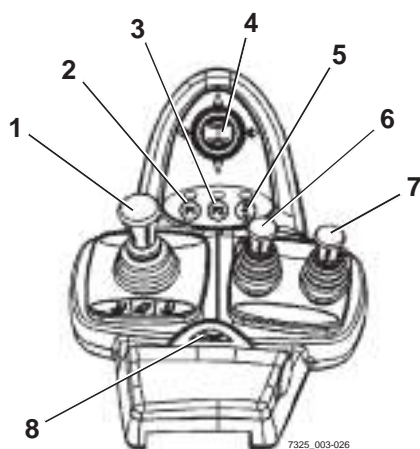

- | | | | |
|---|--|---|--|
| 1 | "Lift mast" 360° lever | 5 | Function key "5th function" |
| 2 | Function key F1 | 6 | "Auxiliary hydraulics 1" operating lever |
| 3 | Function key F2 | 7 | "Auxiliary hydraulics 2" operating lever |
| 4 | "Drive direction/turn indicator" cross lever | 8 | Signal horn button |

NOTE

Depending on the equipment, various electric attachment parts can be controlled via function keys (2) and (3). Changes must only be made by the STILL service centre.

Operating and display elements

Four-way mini-lever

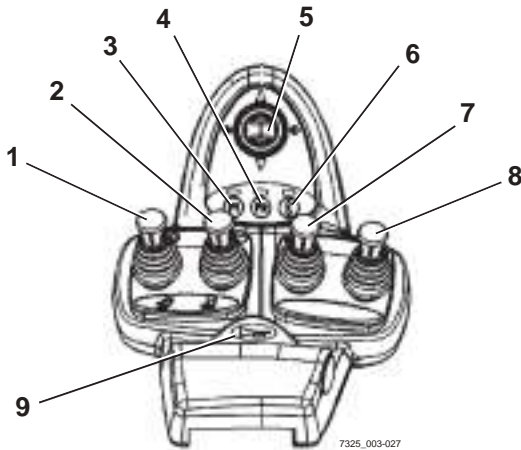

7325_003-027

- | | | | |
|---|--|---|--|
| 1 | "Lift/lowe" operating lever | 6 | Function key "5th function" |
| 2 | "Tilt" operating lever | 7 | "Auxiliary hydraulics 1" operating lever |
| 3 | Function key F1 | 8 | "Auxiliary hydraulics 2" operating lever |
| 4 | Function key F2 | 9 | Signal horn button |
| 5 | "Drive direction/turn indicator" cross lever | | |

 **NOTE**

Depending on the equipment, various electric attachment parts can be controlled via function keys (3) and (4). Changes must only be made by the STILL service centre.

Joystick 4Plus

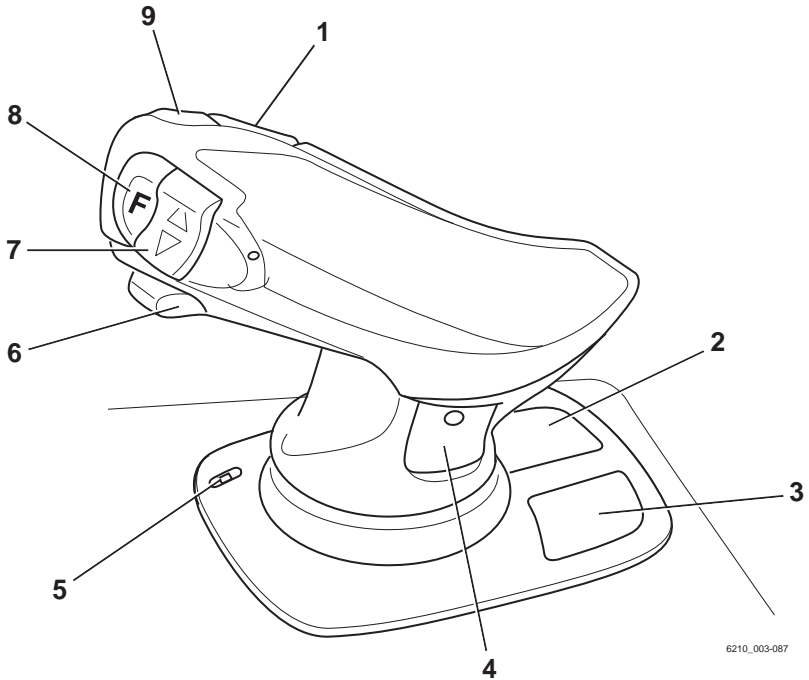

- | | | | |
|---|---|---|--|
| 1 | Horizontal rocker button for "3rd hydraulic function", tilt the lift mast | 5 | LED for clamp locking mechanism (variant) |
| 2 | Pictograms for the basic hydraulic functions | 6 | Slider for the "4th hydraulic function", e.g. reach frame forwards/backwards |
| 3 | Pictograms for the 5th hydraulic function and the clamp locking mechanism (variant) | 7 | Vertical rocker button for the "drive direction" |
| 4 | Pictograms for the 3rd & 4th hydraulic functions | 8 | Shift key "F" |
| | | 9 | Signal horn button |

Operating and display elements

Fingertip

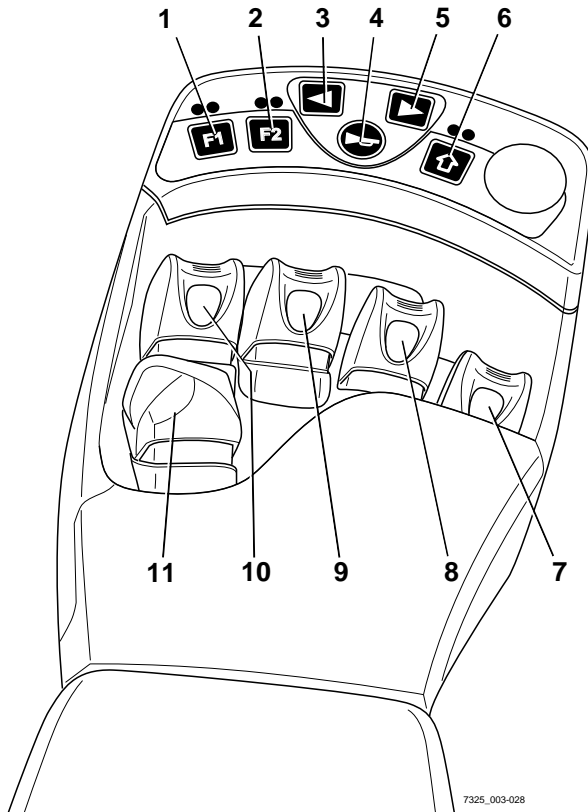

- | | | | |
|---|-----------------------------|----|-------------------------------|
| 1 | Function key F1 | 7 | "Attachments" operating lever |
| 2 | Function key F2 | 8 | "Attachments" operating lever |
| 3 | Left turn indicator button | 9 | "Tilt" operating lever |
| 4 | Signal horn button | 10 | "Lift/lower" operating lever |
| 5 | Right turn indicator button | 11 | Drive direction switch |
| 6 | Function key "5th function" | | |

**NOTE**

Depending on the equipment, various electric attachment parts can be controlled via function keys (1) and (2). Changes must only be made by the STILL service centre.

Mini console

The mini console is located on the steering column below the steering wheel.

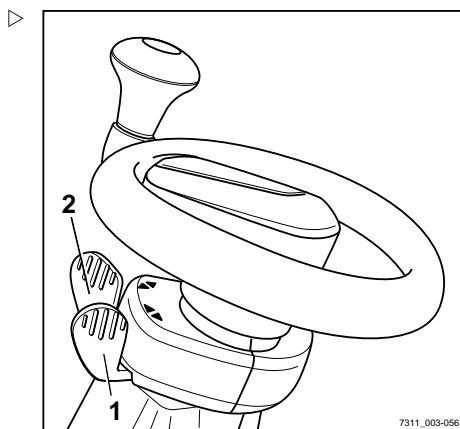

- 1 Travel direction switch
- 2 Direction indicator switch

4

Operation

Testing and activities before daily use

Testing and activities before daily use

Visual inspections

⚠ WARNING

Risk of accident due to damage or other defects on the truck or on the attachment (variant)!

Damage to the truck or the attachment (variant) can lead to unpredictably dangerous situations. If damage or other defects are identified on the truck or attachment (variant) during the following inspections, the truck may not be used until it has been properly repaired.

- Do not remove or deactivate safety systems or switches.
- Do not change any predefined set values.
- Do not use the truck until it has been properly repaired.

⚠ WARNING

There is a risk of falling when working on high parts of the truck.

- Use only the steps provided on the truck.
- Do not stand on truck components or use them to help you mount the truck.
- Use suitable equipment.

Before the truck is used each day, ensure that it is safe to be operated: ▷

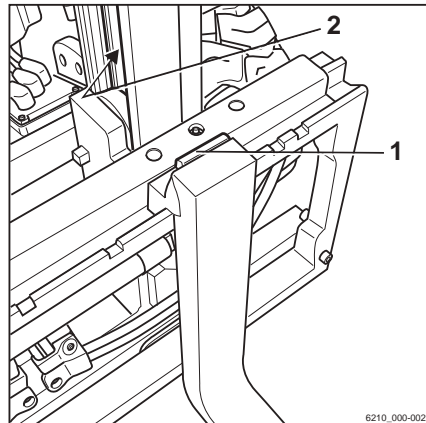

Load lift system unit

Unit	Component	Course of action
Load lift system	Fork arms, general lifting accessories	Perform a visual inspection for deformation and wear (for example, bent, broken, significant wear). Check the condition and function of fuses (1) to prevent lifting and shifting.
	Roller tracks (2)	Make sure that there is a film of grease.
	Load chains	Perform a visual inspection to ensure that the chains are intact and have adequate and even tension.
	Attachments (variant)	Ensure correct mounting in accordance with the operating instructions of the manufacturer. Perform a visual inspection to ensure the attachments are intact and not leaking. Perform checks to ensure the attachments are working correctly.

Testing and activities before daily use

Unit	Component	Course of action
Chassis, bodywork and fittings	Underside	Check the area under the forklift truck for leaking consumables.
	Overhead guard, guard grille (variant)	Perform a visual inspection for integrity. Check for secure mounting.
	Steps	Make sure they are clean (free of ice, not slippery).
	Panes of glass (variant)	Perform a visual inspection for integrity. Make sure they are clean (also free of ice).
	Handholds	Check for secure mounting.
	Maintenance lids	Check the close function and close the lids.
	Fuel system, fuel tank	Perform a visual inspection for damage and leaks. Damaged hoses must be replaced by the authorised service centre.
	Bonnet and side flap	Perform a visual inspection for integrity and deformation. Check that the lock is in good condition and is working correctly. Check the close function. Close.
	Coupling pin, tow coupling (variant)	Perform a visual inspection for deformation and wear (for example, bent, torn, broken). Check the securing bush in the counterweight for integrity and that it is working correctly. Check that the linchpin is present and working correctly (chain, rope, split pin).
	Labelling, adhesive label	Check that labels are present and intact/legible. Replace damaged or missing adhesive labels in accordance with the chapter entitled "Labelling points".
	Driver's seat, seat belt	Check the integrity and function.
	Lighting, warning units	Check the integrity and function.
Antistatic belt	Perform a visual inspection for integrity. Ensure cleanliness. Make sure that the antistatic belt is still long enough to touch the ground below the truck.	

Unit	Component	Course of action
Hydraulics	Lift and tilt cylinders, tank, valve block, hoses, pipes, connections	Perform a visual inspection for damage and leaks. Check the area under the forklift truck for leaking consumables. Damaged hoses must be replaced by the authorised service centre.
		Perform a visual inspection for wear and damage. Make sure that only rims of the same type from the same manufacturer are fitted. In the event of uneven tyre wear, replace both tyres. Observe the safety regulations in the chapter entitled "Tyres".
Chassis frame	Wheels, tyres	Perform a visual inspection for wear and damage. Make sure that only rims of the same type from the same manufacturer are fitted. In the event of uneven tyre wear, replace both tyres. Observe the safety regulations in the chapter entitled "Tyres".
	Axle	Make sure that no consumables are escaping from the axle.

- Do not use the truck if there is any damage or defects.
- Contact your authorised service centre.

Checking the cooling fluid level

The cooling fluid level is monitored by a sensor.

As soon as the message COOLANT LEVEL appears on the display, proceed as follows.

⚠ WARNING

Risk of scalding due to hot cooling fluid!

The cooling system is pressurised! Opening the cooling fluid tank may result in hot cooling fluid leaking out. Only open the cooling fluid tank when the cooling system is cool.

- Switch off the engine and let it cool down.
- Do not open the cooling fluid tank until the truck has cooled down.

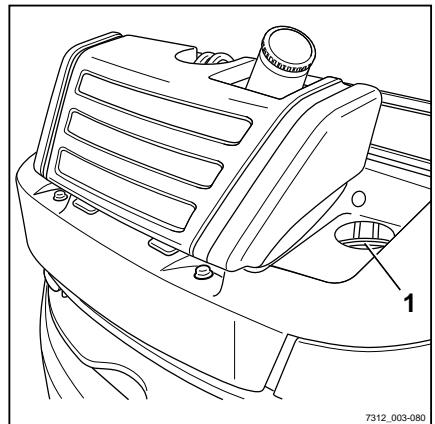

7312_003-080

⚠ WARNING

Coolant and cooling fluid can pose a hazard to health and the environment!

- Observe the safety regulations set out in the chapter entitled "Coolant and cooling fluid".
- Check coolant level.

Testing and activities before daily use

The level must be visible in the middle of the coolant reservoir (1).

- Top up the cooling fluid if necessary; see the section entitled "Topping up the cooling fluid and checking the coolant concentration".

⚠ CAUTION

Risk of engine damage!

If the coolant level is low, this indicates a leak in the cooling system.

- Check the cooling system for leaks; see the section entitled "Cleaning the radiator, checking for leaks".

Checking the engine oil level

NOTE

The truck should be parked on as level ground as is possible while this check is carried out.

- Open the bonnet; see ⇒ Chapter "Opening the bonnet", P. 5-317.
- Pull out the oil dipstick (1) and wipe it.
- Insert the oil dipstick to the stop and pull out again. Make sure that the insertion marks (2) are aligned when inserting.

The oil level must be between the marks (arrows).

- If the oil level is only up to the lowest mark, top up the oil according to the maintenance data table; see ⇒ Chapter "Maintenance data table", P. 5-314.
- Insert the oil dipstick to the stop. Make sure that the insertion marks (2) are aligned when inserting.
- Close the bonnet; see ⇒ Chapter "Closing the bonnet", P. 5-317.

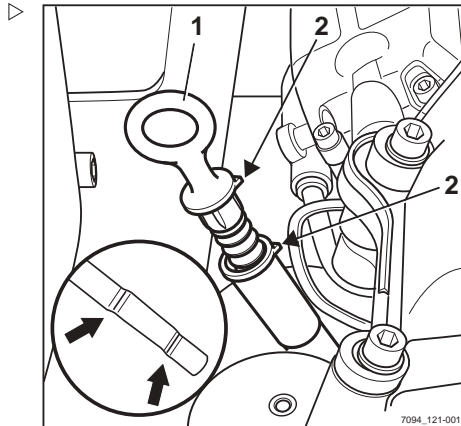

Climbing in and out of the truck

WARNING

Risk of injury when climbing into and out of the truck due to slipping, striking parts of the truck or becoming stuck!

If the footwell cover is very dirty or smeared with oil, there is a risk of slipping. There is a risk of hitting your head on the post of the overhead guard or of your clothes becoming stuck when climbing out of the truck.

- Ensure that the footwell cover is non-slip.
- Do not jump into or out of the truck.
- Ensure that you have a secure grip on the truck.

WARNING

Risk of injury when jumping out of the truck!

If your clothing or jewellery (e.g. watch, ring etc.) become stuck on a component while you are jumping out of the truck, this can lead to serious injuries (e.g. from falling, loss of fingers etc.). It is forbidden to jump out of the truck.

- Do not jump out of the truck.
- Do not wear jewellery at work.
- Do not wear loose-fitting workwear.

CAUTION

Components may become damaged through incorrect use!

Truck components, such as the driver's seat, steering wheel, parking brake lever etc., are not designed to be used for climbing in and out of the truck and can be damaged due to misuse.

- Only use the fittings specifically designed for the purpose of climbing in and out of the truck.

Testing and activities before daily use

To assist with climbing into and out of the truck, the footwell must be used as a step (5) and the handle (2) must be used for support. The post of the overhead guard (1) can also be used for support.

Always climb into the truck in a forwards motion:

- Grip the handle (2) with your left hand and hold on.
- Put your left foot on the step (4).
- Enter the truck with your right foot first and sit down on the driver's seat (3).

Always climb out of the truck backwards:

- Grip the handle (2) with your left hand and hold on.
- Stand up from the driver's seat and place your left foot on the step (4).
- Climb out of the truck right foot first.

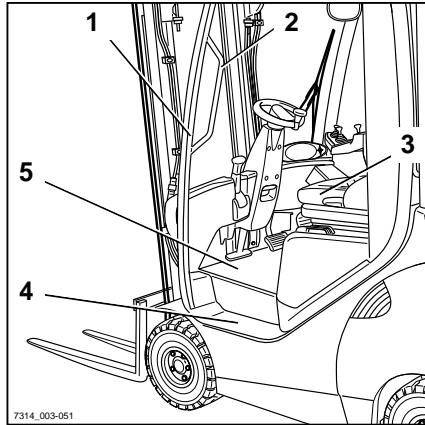

Shelves and cup holders

⚠ WARNING

Objects may fall into the footwell and obstruct the pedals, which poses a risk of accident!

Objects to be stored must be of the correct size so that they cannot fall from the shelf (1) or out of the cup holder (2). Objects that fall into the footwell during travel as a result of steering or braking may slip between the pedals (3) and prevent them from working correctly. The truck may subsequently not be able to be braked when necessary.

- Bottles of max. 0.5 l may be stored in the cup holder.
- Make sure that stored objects cannot fall from the shelves when the truck is started up, steered and braked.

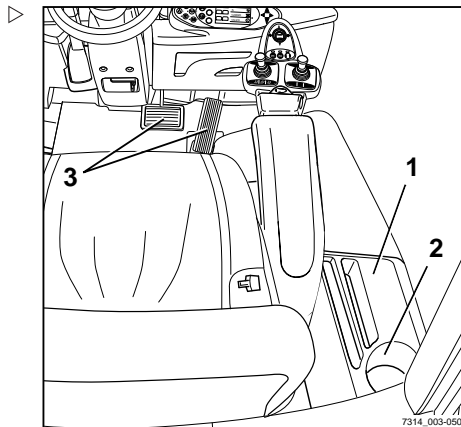

Adjusting the MSG 65/MSG 75 driver's seat

⚠ DANGER

There is a risk of accident if the seat or seat backrest shifts suddenly, which could cause the driver to move in an uncontrolled manner. This may result in unintentional actuation of the steering or operating devices and thus cause the truck or load to move in an uncontrolled fashion.

- Do not adjust the seat or seat backrest while driving
- Adjust the seat and the seat backrest so that all operating devices can be actuated safely
- Ensure that the seat and seat backrest are securely engaged



⚠ WARNING

On some equipment variants, the amount of head clearance on the truck may be restricted.

On these specific equipment variants, the distance between the head and the lower edge of the roofing sheet must be at least 40 mm.

i NOTE

If there are separate operating instructions for the seat, they must be followed.

⚠ WARNING

To obtain optimum seat cushioning, you must adjust the seat suspension to your own body weight. This is better for your back and protects your health.

- To prevent injury, make sure that there are no objects within the swivel area of the seat

Testing and activities before daily use

Moving the driver's seat

- Lift and hold the lever (1)
- Push the driver's seat into the desired position.
- Release the lever.
- Ensure that the driver's seat is securely engaged.

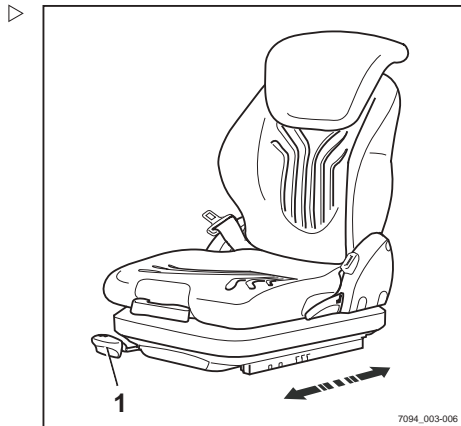
**Adjusting the seat backrest**

Do not put pressure on the seat backrest while engaging it.

- Lift and hold the lever (2)
- Push the seat backrest into the desired position.
- Release the lever.
- Ensure that the seat backrest is securely engaged.

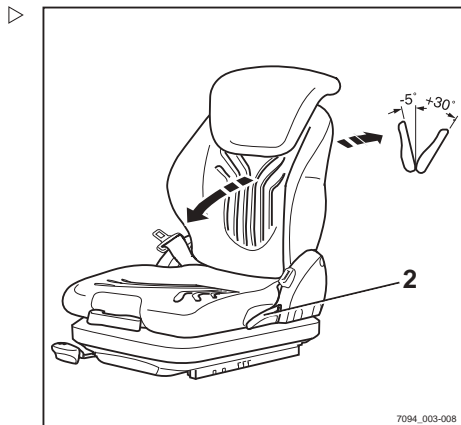
**NOTE**

The backwards tilt angle of the seat backrest can be restricted by the structural condition of the truck.

Adjusting the seat suspension

i NOTE

The driver's seat can be adjusted to suit the weight of the individual driver. In order to achieve the best seat suspension setting, the driver should perform the adjustment whilst sitting in the seat.

i NOTE

The driver's seat MSG 65/MSG 75 is designed for people weighing between 45 kg and 170 kg.

i NOTE

The MSG 75 seat is equipped with electric air suspension that is activated using an electric switch instead of the lever (3).

- Fully extend the weight-adjusting lever (3)
- Pump it up or down to set the driver's weight.
- Return the weight adjusting lever to the central initial position before each new lift (audible click).
- Fully fold in the weight adjusting lever once adjustment is complete.

i NOTE

The driver's weight has been selected correctly when the arrow (4) is in the centre of the inspection window. If the seat does not move any further when you pump the weight adjusting lever, the minimum or maximum weight setting has been reached.

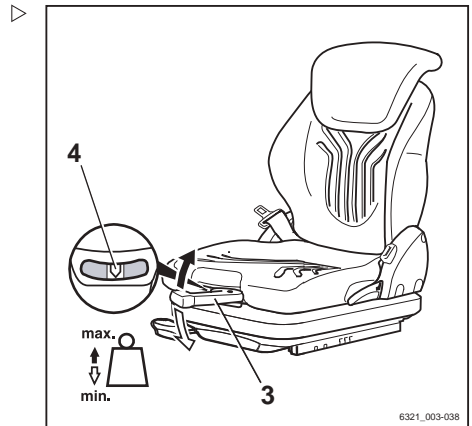

Testing and activities before daily use

Adjusting the lumbar support (variant) ▷

i NOTE

The lumbar support can be adjusted to suit the contours of the individual driver's spine. Adjusting the lumbar support moves a convex support cushion into the upper or lower part of the backrest.

- Turn the turning knob (5) up or down until the lumbar support is in the desired position

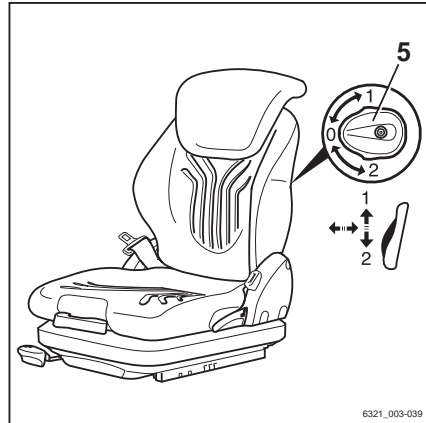

Adjusting the backrest extension (variant) ▷

- Adjust the backrest extension (6) by pulling it out or pushing it into the desired position.

To remove the backrest extension, move it past the end stop by jolting it upwards.

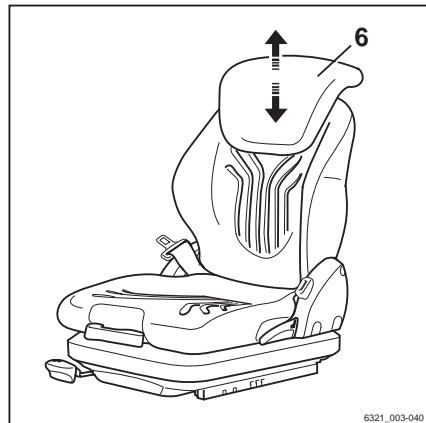

Switching the seat heater (variant) on and off

NOTE

The seat heater only functions if the seat contact switch is active, i.e. when the driver is sitting on the driver's seat.

- Switch the seat heater (7) on or off using the switch.

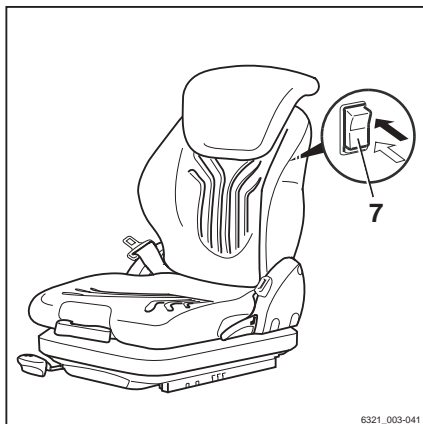

Adjusting the armrest

DANGER

There is a risk of accident if the armrest lowers suddenly, causing the driver to move in an uncontrolled manner. This can result in unintentional actuation of the steering or the operating devices and thus cause uncontrolled movements of the truck or load.

- Do not adjust the armrest while driving.
- Adjust the armrest so that all operating devices can be actuated safely.
- Ensure that the armrest is securely tightened.

Testing and activities before daily use

Adjusting the length of the armrest

- Release the star-grip handle (1) by turning it anti-clockwise.
- Shift the armrest (2) into the desired position.
- Tighten the star-grip handle by turning it clockwise.
- Check that the armrest is firmly attached.

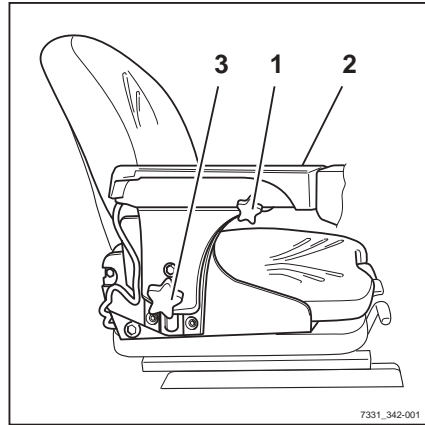

Adjusting the height of the armrest

- Release hand wheel (3) by turning it anti-clockwise.
- Shift the armrest (2) into the desired position.
- Tighten the hand wheel by turning it clockwise.
- Check that the armrest is firmly attached.

Adjusting the steering column

- Press down the steering column adjustment lever (2).
- Position the steering column (1) and pull the lever up again.

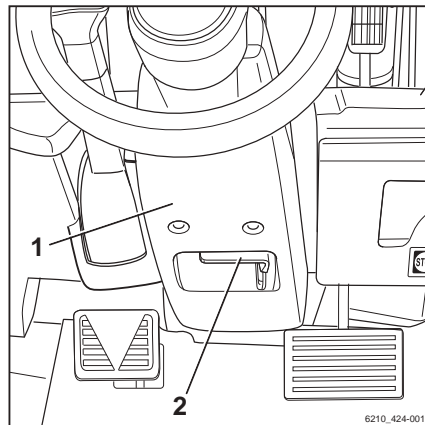

⚠ DANGER

Risk of accidents!

- Ensure that the steering column is secure.
- The steering column must click into place.
 Never adjust the steering column while driving.

Unlocking the emergency off switch

i NOTE

Only diesel trucks with a particle filter system (variant) or a joystick 4Plus (variant) have an emergency off switch.

- Pull the emergency off switch (1) until it unlatches.

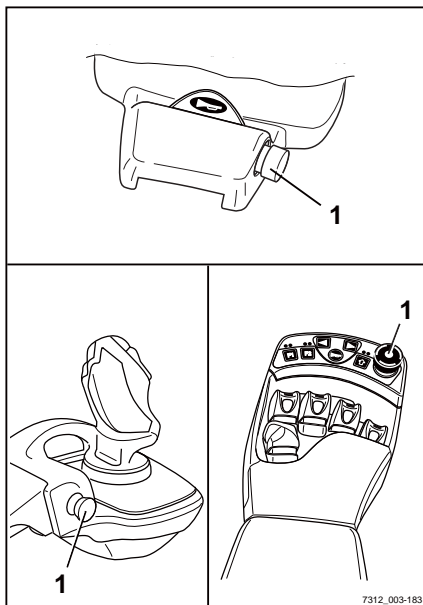

Switching on the key switch

WARNING

Before switching on the key switch, all tests prior to start-up must be performed without detecting any defects.

- Perform the tests prior to commissioning.
- Do not operate the truck if defects have been detected
- Notify the authorised service centre.

Testing and activities before daily use

- ▷ – Insert the switch key (1) into the key switch and turn to position "I"

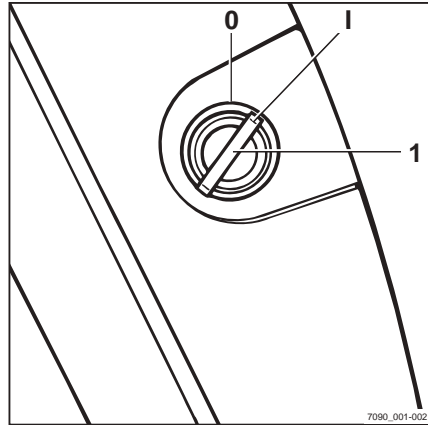

- ▷ This initiates a self-test. All lamps in the drive direction and turn indicator displays light up briefly.

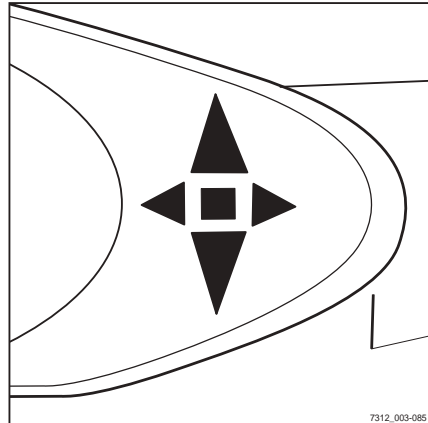

When the key switch is switched on, the display shows the welcome screen in the set language until the truck controls have completely started up.

If the truck has the "access authorisation with PIN code" variant, the display initially changes to the input menu for access authorisation.

If the truck is ready for operation, the standard displays are shown.

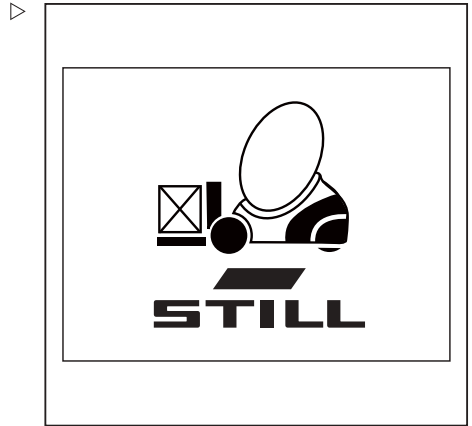

Standard display elements

In the factory setting, the following indicators can be seen in the display and operating unit:

- 1 **Fuel level**
Shows the fuel level in the fuel tank as a percentage (%).
- 2 **Drive programme**
Displays the current drive programme numerically (1-5). The drive programme can be changed; see the chapter entitled "Setting the drive programme".
- 3 **Operating hours**
Displays the total operating hours completed by the truck. The hour meter operates as soon as the engine is started.
- 4 **Time**
Displays the current time digitally in hours and minutes. The time can be adjusted; see the chapter entitled "Setting the time".

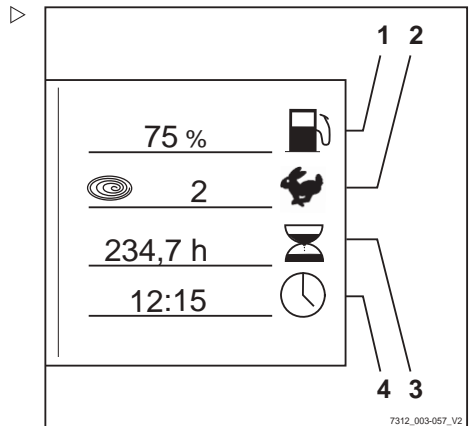

⚠ CAUTION

Lack of fuel can cause malfunctions!
If the fuel tank has been run empty, the fuel injection system can draw in air bubbles. This can lead to malfunctions in the fuel injection system.

- Never run the fuel tank empty.

Testing and activities before daily use

NOTE

Additional information may appear on the display. If faults occur, refer to the information in the chapter entitled "Faults".

Access authorisation with PIN code (variant)

Description

Trucks equipped with the "Access authorisation with PIN code" variant are protected against unauthorised use by a five-digit driver PIN. Up to fifty different driver PINs can be defined so that the same truck can be used by different drivers, each with their own driver PIN.

NOTE

The driver PINs are defined in a truck control unit menu that can only be accessed by persons with the corresponding access authorisation, e.g. fleet managers.

Once the key switch has been switched on, the input menu for the driver PIN appears on the display and operating unit screen. All of the truck's functions (driving, hydraulics, additional electrical installations and the display and operating unit displays) are blocked. The function of the hazard warning system (variant) is guaranteed. Enter the five-digit driver PIN (possible entries from 00000 to 99999) to enable the blocked functions. Once the correct driver PIN has been entered, the standard displays are shown. All of the truck functions are available.

The access authorisation can be configured in such a way that the driver PIN has to be re-entered each time the driver steps off the truck, in order for the truck to be operated again.

- Contact the authorised service centre on this matter.

The first driver PIN is preset to "11111" at the factory. All others are preset to "0xFFFF" but have no function as the highest valid driver PIN

is "99999". Persons with the corresponding access authorisation, e.g. fleet managers, can change the driver PINs in the corresponding menu.

NOTE

When first commissioning the truck, we recommend you change the access authorisation set at the factory. This is the only way to guarantee that the driver PIN is only known to persons with corresponding access authorisation.

The driver PINs are stored in the truck control unit. These are still available if the display and operating unit has been changed. The authorised service centre can use a diagnostic device to read out the driver PIN and, if necessary, restore the factory default driver PIN.

ACCESS CODE input menu

The driver enters the five-digit driver PIN (00000 to 99999) in this input menu.

The driver PIN is entered using the buttons (1). The digits entered for the driver PIN (2) are not visible, instead being represented by circles. If the driver PIN entered is correct, the familiar display appears with the standard display, and all truck functions are available.

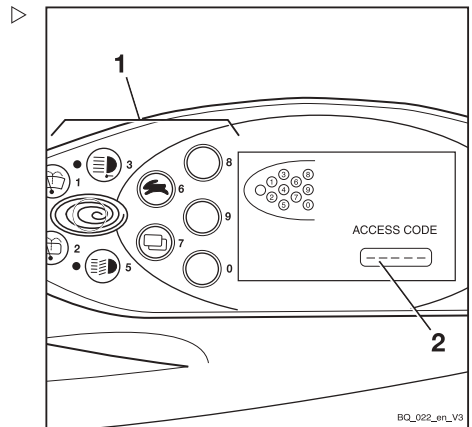

Testing and activities before daily use

If an incorrect driver PIN is entered, the message `INVALID` appears for a short time. When the message goes out, the driver PIN can be re-entered.

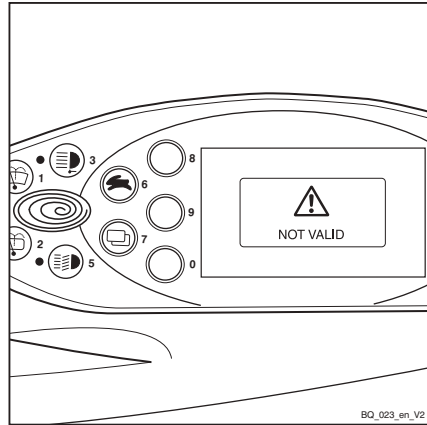

After three invalid entry attempts, the message `CODE DENIED` appears. The input is then locked for five minutes before another attempt can be made.

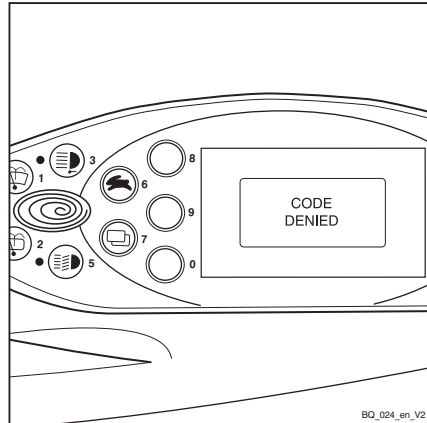

Defining the driver PIN

i NOTE

The driver PIN can only be defined by persons with the corresponding access authorisation, e.g. fleet managers. In order for the fleet manager to define the driver PIN, the configuration menu is password-protected. After entering the password, the fleet manager can configure general settings for the truck. To change the password, see the chapter entitled "Changing the password".

- Push the drive program selection button (1) and the menu change button (2) at the same time.

PASSWORD appears in the display.

- Enter the four-digit password (factory default: 2777) using the buttons (1).
- Confirm the entry by pressing the **ENTER** button (2).

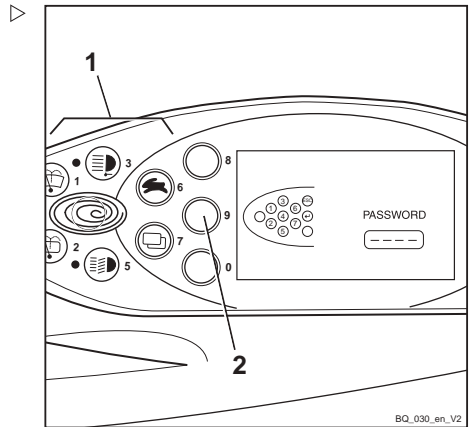
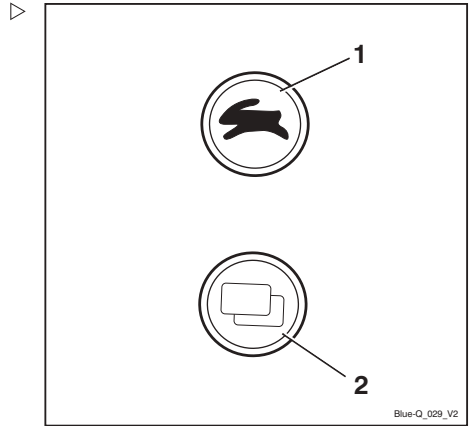

Testing and activities before daily use

CONFIGURATION appears in the display. ▷

- Use the drive program selection button (1) and the menu change button (3) to select the ACCESS CODE menu.
- Confirm your selection by pressing the **ENTER** button (2).

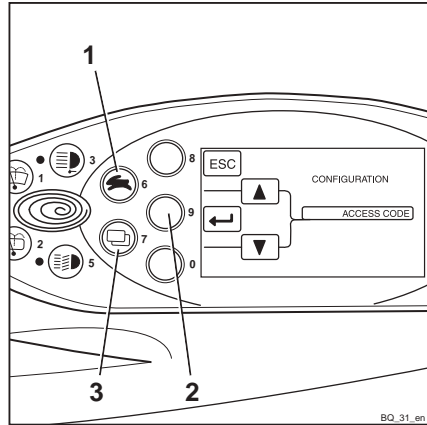

Selecting the driver PIN

In the ACCESS CODE menu, there are fifty possible driver PINs to choose from. ▷

The digit sequences can be set or changed in the NEW CODE submenu.

Once the ACCESS CODE menu has been accessed, the CODE selection field (2) contains the number 1. The first of the fifty driver PINs can now be defined.

- Use the drive program selection button (1) and the menu change button (4) to select the desired driver PIN (1 to 50).
- Confirm your selection by pressing the **ENTER** button (3).

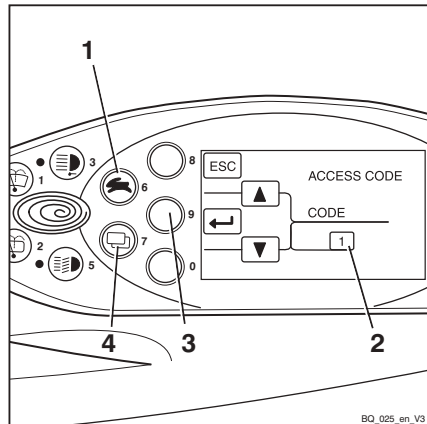

NEW CODE appears in the display.

- Enter the desired driver PIN using the buttons (5).

The digits entered do not appear in the display. Instead they are represented by circles in the NEW CODE field (6).

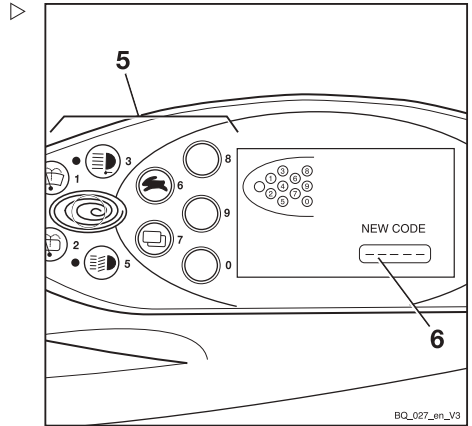

CONFIRM appears in the display.

The CONFIRM submenu is used to confirm the new driver PIN.

- Enter the new driver PIN for a second time in the CONFIRM field (8) using the buttons (7).

If the entry matches the new driver PIN previously entered, the system will accept the new driver PIN once the last digit has been entered. The display switches back to the ACCESS CODE menu.

Another driver PIN can be defined here.

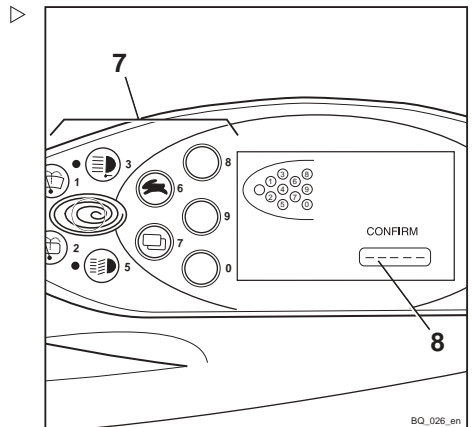

Testing and activities before daily use

If the driver PIN entered in the CONFIRM submenu does not match the driver PIN entered previously in the NEW CODE submenu, the message INVALID will appear.

The message will then disappear after a short time. The new driver PIN can be entered in the CONFIRM submenu for further confirmation.

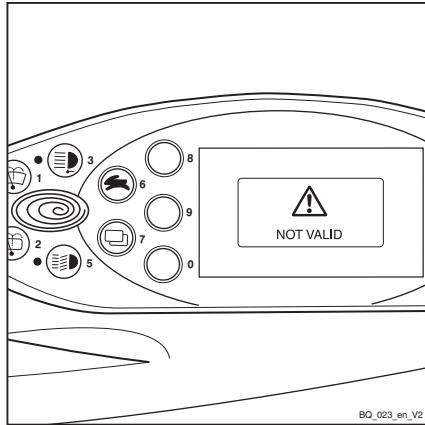

After three incorrect entries, the CODE DENIED message appears.

The display switches back to the ACCESS CODE menu. The desired driver PIN must be re-defined.

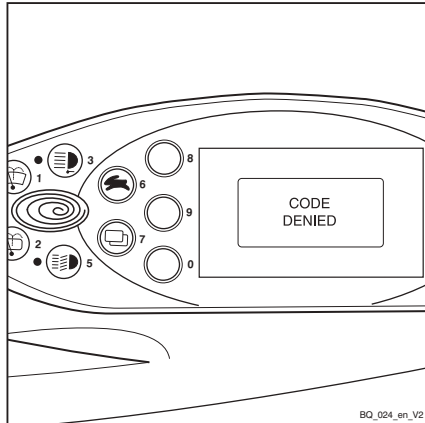

Changing the password

It is recommended that you change the factory default password.

i NOTE

The password can only be changed when the parking brake is applied.

- Push the drive program selection button (1) and the menu change button (2) at the same time.

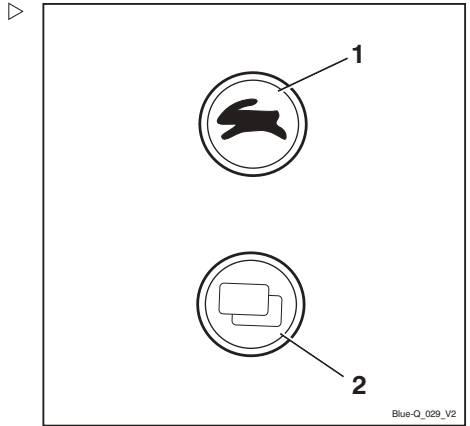

PASSWORD appears in the display.

- Enter the current password using the buttons (1).
- Confirm the entry by pressing the **ENTER** button (2).

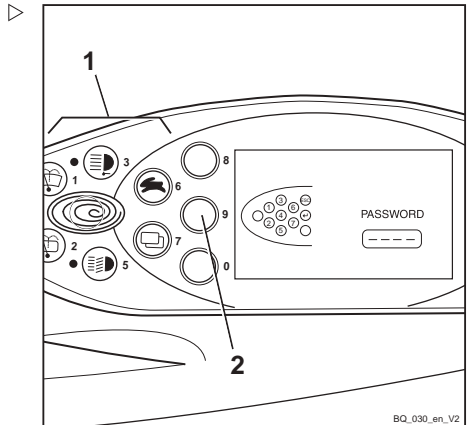

Testing and activities before daily use

CONFIGURATION appears in the display. ▷

- Use the drive program selection button (1) and the menu change button (3) to select the PASSWORD menu.
- Confirm your selection by pressing the **ENTER** button (2).

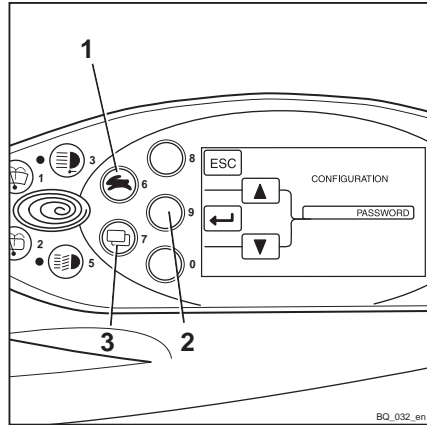

PASSWORD / PASSWORD LEVEL appears in the display. ▷

- Use the drive program selection button (1) and the menu change button (4) to select the desired PASSWORD LEVEL (2).
- Confirm your selection by pressing the **ENTER** button (3).

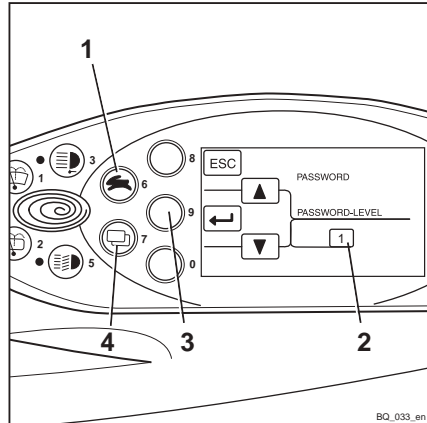

NEW CODE appears in the display.

The four-digit password can be entered using the buttons (1).

⚠ CAUTION

Do not enter the password 1777!

If this password is entered, the configuration options for the fleet manager are restricted to driver authorisations and cannot be reset independently.

The authorisations can only be reset by the authorised service centre!

- Enter the new desired password using the buttons (1).

The digits entered are shown in plain text in the NEW CODE field (4).

- Confirm your selection by pressing the **ENTER** button (3).

In the NEW CODE field, - ? ? - appears briefly. The new password is confirmed.

- To correct the new password, push the **ESC** button (2).

The display switches back to PASS-WORD / PASSWORD LEVEL.

- Repeat the process steps from PASS-WORD / PASSWORD LEVEL.
- To exit the configuration menu, push the **ESC** button repeatedly until the standard displays appear.

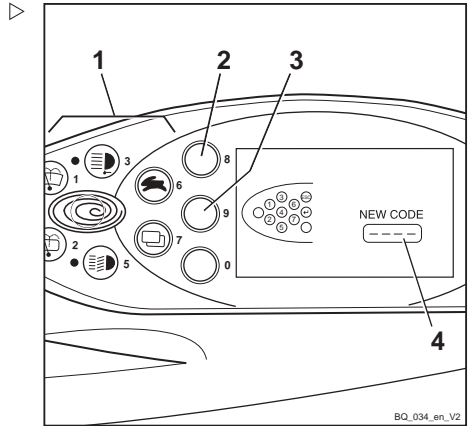

Testing and activities before daily use

Operating the signal horn

- Push the signal horn button (1).

The signal horn sounds.

**NOTE**

The signal horn is used to warn people against imminent danger or to announce your intention to overtake.

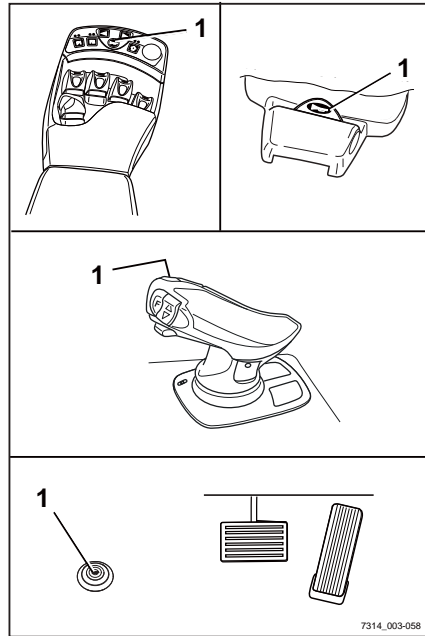

7314_003-058

Seat belt**⚠ DANGER**

Even when using an approved restraint system, there is some residual risk that the driver might be injured if the truck tips over.

This risk of injury can be reduced through the combined use of the restraint system and the seat belt.

In addition, the seat belt protects against the consequences of rear-end collisions and falling off a ramp.

- We therefore recommend that you also use the seat belt.

⚠ DANGER

Only bracket doors (variant) or the driver's cab (variant) with closed, fixed doors constitute a driver restraint system. Plastic doors (weather protection) do not constitute a restraint system!

If you need to open or remove the doors, you must use an alternative suitable restraint system (e.g. a seat belt).

Fastening the seat belt**⚠ DANGER****Risk to life when driving without a seat belt!**

If the truck tips over or crashes into an obstacle and the driver is not wearing the seat belt, the driver may be thrown from the truck. The driver could slide under the truck or collide with an obstacle.

There is a risk of fatal injury!

- Fasten the seat belt before every trip.
- Do not twist the seat belt when fastening it.
- Only use the seat belt to secure one person.
- Have any malfunctions repaired by the authorised service centre.

i NOTE

The buckle has a buckle switch (variant). In the event of an operating error or malfunction, the message SAFETY BELT appears in the display and operating unit, see the chapter entitled "Display messages".

- Pull the seat belt (3) out of the belt retractor without jerking and fasten closely around the body over the thighs.

i NOTE

Sit as far back as possible so that your back is leaning against the seat backrest. The automatic blocking mechanism permits sufficient freedom of movement on the seat.

- Click the belt tongue (2) into buckle (1).
- Check tension of the seat belt. It should be close to the body.

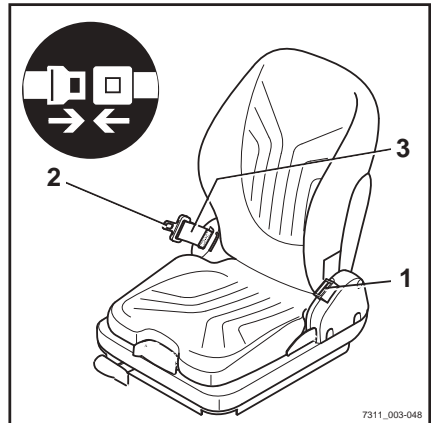

Testing and activities before daily use

Fastening on a steep slope

The automatic blocking mechanism prevents the belt from being extended whenever the truck is on a steep gradient. It is not possible to pull the seat belt any further out of the belt retractor.

- Move away carefully on the slope.
- Fasten the seat belt.

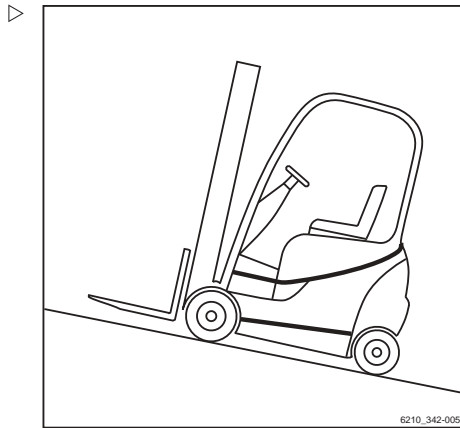

Releasing the seat belt

- Push the red button (4) on the buckle (1).
- Manually guide the belt tongue slowly back to the retractor.

NOTE

Do not allow the seat belt to retract too quickly. The automatic blocking mechanism may be triggered if the belt tongue strikes the housing. It will then no longer be possible to pull the seat belt out with the usual force.

- Using increased force, pull the seat belt around 10-15 mm out of the retractor to disengage the blocking mechanism.
- Slowly allow the seat belt to retract again.
- Protect the seat belt from dirt (for example, by covering it).

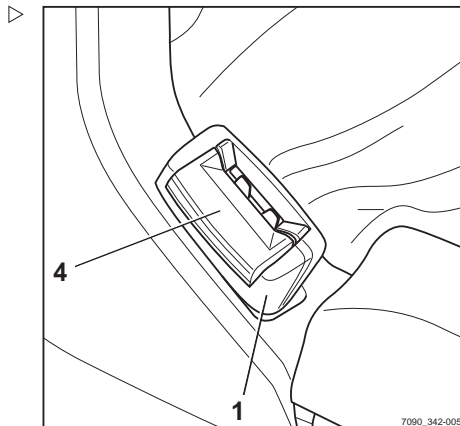

Malfunction due to cold

- If the buckle or belt retractor is frozen, thaw them out and dry them thoroughly to prevent recurrence.

⚠ CAUTION

The seat belt may be damaged by heat!

Do not subject the buckle or belt retractor to excessive heat when thawing.

- Do not use air warmer than 60°C when thawing.

Driver's cab**⚠ DANGER**

Risk of fatal injury in the event of falling from the truck if it tips over!

In order to prevent the driver from sliding underneath the truck and being crushed if the truck tips over, a restraint system must be in place and must be used. The restraint system prevents the driver from being thrown from the truck if it tips over. The driver's cab constitutes a driver restraint system only if the cab door is sturdy and closed. Fabric-covered cabs (variant) with doors made of plastic or canvas do not constitute a driver restraint system and offer no protection from the consequences of the truck tipping over!

- Close the cab door before operation
- If the door is open or has been removed, use a comparably secure restraint system
- We recommend that you always use the seat belt

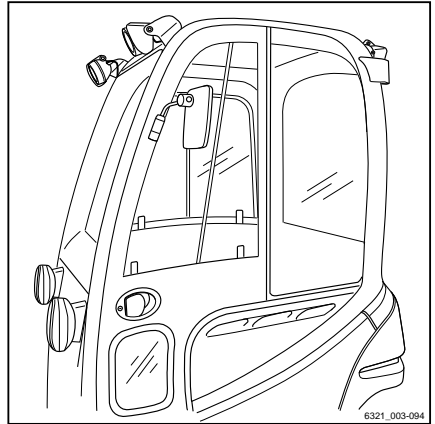

Testing and activities before daily use

Starting the engine

⚠ DANGER**Risk to health from exhaust gases!**

Exhaust gases from internal combustion engines are harmful to your health. In particular, the soot particles contained in the diesel exhaust gas can cause cancer.

When the internal combustion engine is running, there is a risk of poisoning from the CO, CH and NOx components contained in the exhaust gas.

Modern exhaust gas treatment systems (e.g. catalytic converters, particle filters or comparable systems) can clean exhaust gases in a way that reduces the health hazard and risk of poisoning when operating the truck.

- Observe the national laws and regulations when using trucks with an internal combustion engine in entirely or partially enclosed working areas.
 - Always ensure sufficient ventilation.
-
- Apply the parking brake.
 - Insert the switch key (1) into the key switch and turn to position "I"

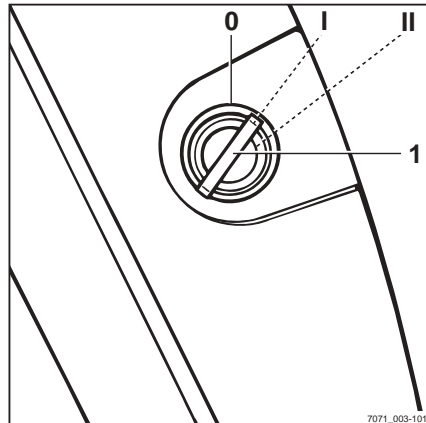

The GLOW display flashes, which indicates that the engine is being preheated.

i NOTE

Preheating can take up to 20 seconds. If the engine is already at operating temperature, preheating is not performed.

- If the START message lights up on the display, turn the switch key to position "II" and hold it in this position until the engine starts
- Release the switch key as soon as the engine has started

If the engine does not start after 20 seconds, stop the starting procedure and repeat after one minute.

⚠ CAUTION

Risk of engine damage!

If the OIL PRESSURE message appears on the display after starting the motor, there may be insufficient engine lubrication. Insufficient lubrication may cause engine damage.

- Stop the engine immediately
 - Check the engine oil level and top up the engine oil if necessary
 - If the message continues to appear, notify the authorised service centre.
-
- Please note the information in the chapter entitled "Faults".

i NOTE

If the engine does not start due to a discharged battery, it can be jump-started.

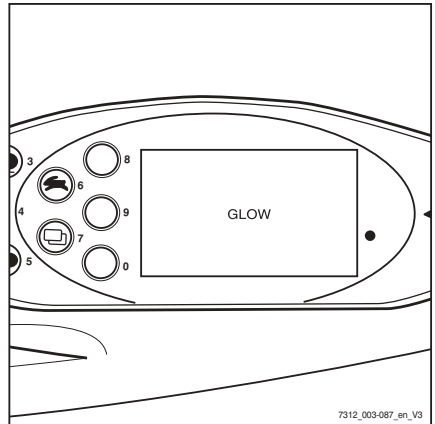

Testing and activities before daily use

Checking the brake system for correct function

⚠ DANGER

If the brake system fails, the truck is insufficiently braked or not braked at all, so there is a risk of accident!

- Do not commission trucks with a defective brake system.

Checking the foot brake

- Check pedal clearance:

There must be a distance of at least 60 mm between the pressure point and the pedal stop.

- Accelerate the truck without a load in a clear area; see "Driving" chapter.
- Press the brake pedal (1) firmly.

The truck must decelerate noticeably.

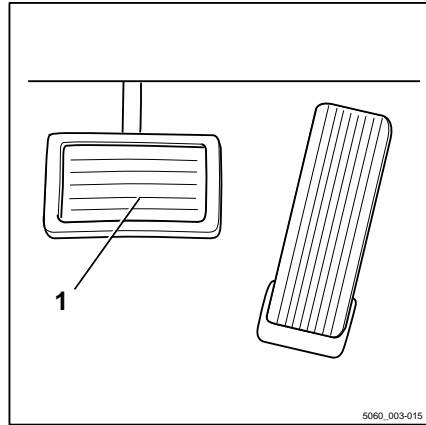

Checking the parking brake

⚠ DANGER

If the truck rolls away, there is a risk of being run over and therefore a danger to life!

- The truck must not be parked on a slope.
- In emergencies, secure with wedges on the side facing downhill.
- Only leave the truck when the parking brake is applied.

- Check the function of the parking brake at walking speed or on a steep gradient by applying the parking brake.

The truck must remain stationary on the gradient with the parking brake applied. If the truck rolls in spite of an actuated parking brake, contact your service centre.

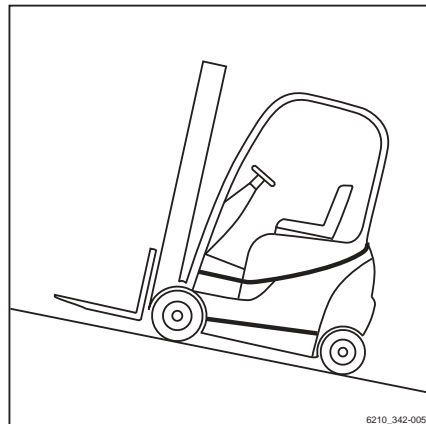

Checking the steering system for correct function

⚠ DANGER

If the hydraulics fail, there is a risk of accident as the steering characteristics have changed.

- Do not operate the truck if it has a defective steering system.
-
- Operate steering wheel (1). The steering play while stationary must not be more than two finger widths.

i NOTE

If the truck is switched on with the steering wheel turned, the maximum driving speed is limited. Travel speed limitation is removed as soon as the steering wheel is moved out of a cornering position into the straight-ahead position. This requires a change in steering angle of about half a revolution.

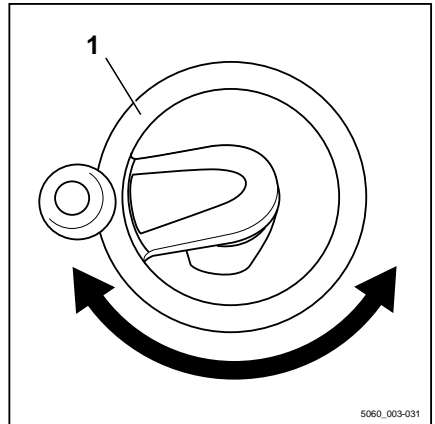

Checking the emergency off function

i NOTE

Only diesel trucks with a particle filter system (variant) or a joystick 4Plus (variant) have an emergency off switch.

⚠ WARNING

No electric braking assistance is available when the emergency off switch is actuated!

Actuating the emergency off switch will de-energise the entire electrical system.

- To brake, actuate the service brake.
-
- Slowly drive the truck forwards.

Testing and activities before daily use

- Press the emergency off switch (1).

The truck will coast

- Brake the truck to a standstill by actuating the brake pedal.

NOTE

In trucks with an electric parking brake, the electric parking brake will be applied as soon as the truck comes to a stop.

- Pull out the emergency off switch (1).

The knob is unlocked and pops out. The truck performs an internal self-test and is then ready for operation again.

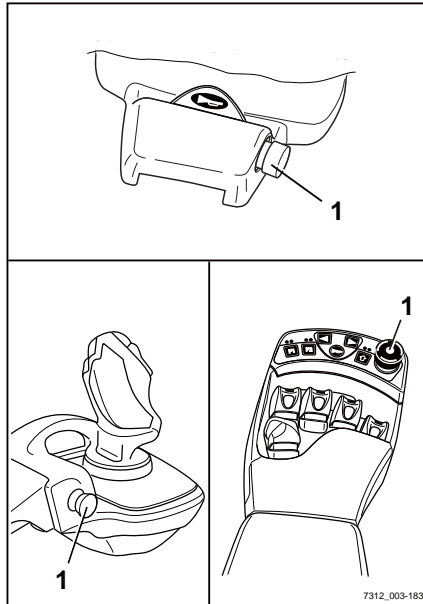

Zero adjustment of the load measurement (variant)

NOTE

A zero adjustment must be carried out in order to guarantee the accuracy of the load measurement (variant) at all times. Zero adjustment is required

- as part of daily commissioning
- after changing the fork arms
- after fitting or changing attachments.

NOTE

Accurate zero adjustment is only possible if the fork is not carrying a load. Do not take up a load yet.

NOTE

Accurate zero adjustment is only possible within the first lifting stage of the lift mast. When carrying out the zero adjustment, do not

raise the fork more than 800 mm above the ground.

i NOTE

Operation of the lifting system depends on which operating devices the truck is fitted with; see ⇒ Chapter "Lifting system operating devices", P. 4-152.

- Set lift mast to vertical.
- Raise the fork to a height of 300–800 mm.
- Keep button (1) for the "zero adjustment" pressed for at least four seconds; the "zero adjustment" (2) symbol will appear in the display.

i NOTE

During the following process, the fork carriage must be lowered slightly and then stopped abruptly. While doing so, the fork must not touch the ground, otherwise the zero adjustment will not be accurate. To stop the lowering procedure quickly, release the operating device for lowering so that it jumps into the zero position.

- Lower the fork carriage slightly and release the operating device.

When the zero adjustment has been carried out correctly, the value "0 kg" appears in the operating unit display.

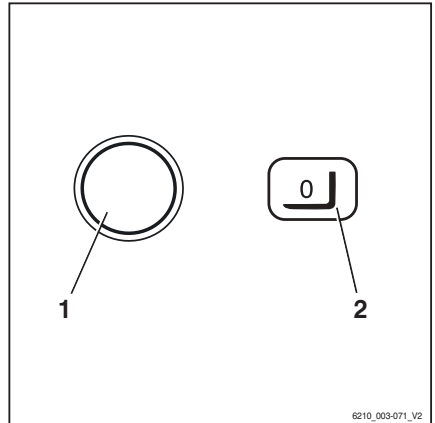

Testing and activities before daily use

Checking the vertical lift mast position (variant) for correct function

NOTE

The function check of the lift mast vertical position (variant) must be carried out every time a truck is commissioned.

- Actuate function key (1) to switch on the comfort feature "lift mast vertical position".

Function display (2) must appear in the display.

- Tilt the lift mast backwards.

The lift mast must tilt back fully and move gently as far as the end stop.

- Tilt the lift mast forward.

The lift mast must tilt forwards and stop in the vertical position.

- Release the operating device to tilt and actuate again.

The lift mast must tilt forwards fully and move gently as far as the end stop.

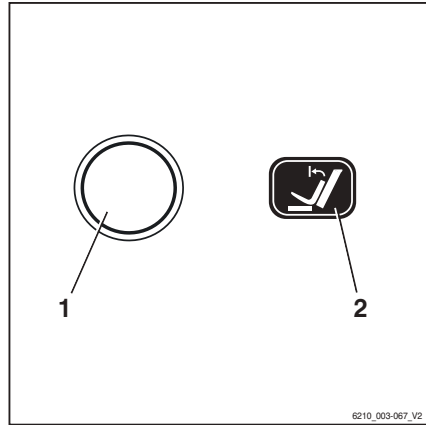

Operation of the display operating unit

Displays

Standard display elements

In the factory setting, the following indicators can be seen in the display and operating unit:

- 1 **Fuel level**
Shows the fuel level in the fuel tank in %.
- 2 **Drive programme**
Displays the current drive programme numerically (1-5). The drive programme can be changed; see the chapter entitled "Setting the drive programme".
- 3 **Operating hours**
Displays the total operating hours completed by the truck. The hour meter operates as soon as the engine is started.
- 4 **Time**
Displays the current time digitally in hours and minutes. The time can be adjusted; see the chapter entitled "Setting the time".

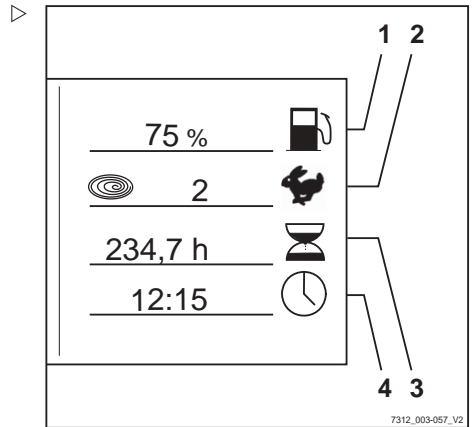

Additional indicators

- 5 **Menu change button**
When the menu change button is pressed, the following additional indicators appear:
- 6 **"Service in" indicator**
Displays the remaining time in hours until the next service work has to be carried out according to the maintenance schedule in the maintenance instructions. Contact the authorised service centre in good time.
- 7 **Total distance**
Displays the total distance driven in kilometres.
- 8 **Daily kilometres**
Displays the kilometres driven for the day.
- 9 **Daily driving time**
Displays the hours driven for the day.

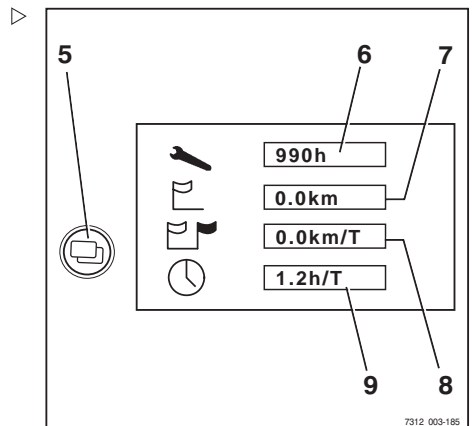

Operation of the display operating unit

Adjusting the displays

NOTE

The parking brake must always be engaged when you adjust the displays. The displays cannot be adjusted if the parking brake is not engaged.

NOTE

When adjusting the displays, do not actuate the hydraulic system operating devices. If you do, entry is interrupted and the display returns to the operating display.

The displays are adjusted in the CONFIGURATION menu.

- Turn the key switch to position "I".
- Press the drive program button (1) and the menu change button (2) at the same time.

The display changes to the PASSWORD menu.

- Press the return key (3).

The display changes to the CONFIGURATION menu.

The following settings are possible and can be found in the corresponding chapter:

- Setting the date and time
- Resetting the daily kilometres and daily operating hours
- Setting the language
- Configuring Blue Q

Symbols in the display









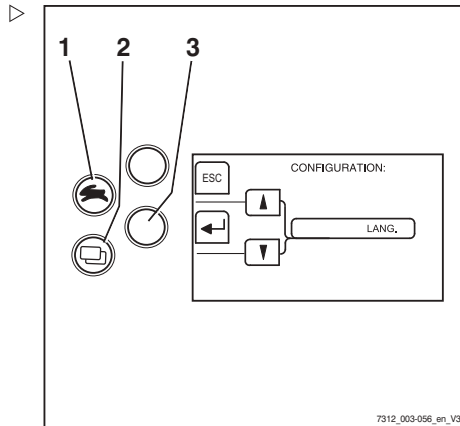











Messages

To show operating messages, warning messages or error messages in the display, text messages and symbols are used.







Symbols for operating messages

Description	Symbol
Empty field	No display
Please wait	







Description	Symbol
Service required	
Lift limitation	
Reference cycle	
Battery charging	
Drive program	
Hour meter	
Odometer	
Daily hour meter	
Daily odometer	
Speed	
Steering angle	
Load	
Time	
Hydraulic system	
Exh. gas purifier	
Coolant temperature	
Fuel level	
Blue-Q	
Power rating (average)	
Power rating (trend)	

Symbols for warning messages

Description	Symbol
Parking brake	
Actuate seat switch	
Safety belt	
Battery acid level	
Neutral warning message	
Are you sure?	
Oil pressure	











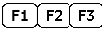







Operation of the display operating unit





Symbols for error messages

Description	Symbol
Brake system malfunction	
Overheating of the engine	
Overheating	
Malfunction in the electrical system	
General malfunction	

Symbols for auxiliary equipment soft key functions











For the auxiliary equipment, the following symbols for the soft key functions are used on the left in the display:

Description	Symbol
Empty field	No display
General function key OFF	
General function key ON	
Rear working spotlight OFF	
Rear working spotlight ON	
Front working spotlight OFF	
Front working spotlight ON	
Windscreen heating OFF	
Windscreen heating ON	
Rear window heating OFF	
Rear window heating ON	
Interior lighting OFF	
Interior lighting ON	
Roof wiper/washer OFF	
Roof wiper/washer ON	
Heater blower OFF	
Heater blower ON	
Rotating beacon OFF	
Rotating beacon ON	

Description	Symbol
Seat heater OFF	
Seat heater ON	
Signal horn OFF	
Signal horn ON	

Symbols for the soft key functions for menu navigation and for acknowledging messages

For menu navigation and to acknowledge messages, the following symbols for the soft key functions are used on the left of the display:

Description	Symbol
Empty field	No display
[ESC] button to return to the main menu	
[ENTER] button to confirm	
[OK] button to confirm	
[RES] button to reset	
Button to return to the main menu	
Button to return to the previous edit field	
[Scroll] button to scroll up	
[Scroll] button to scroll down	
[Scroll] button to count up	
[Scroll] button to count down	

Status LEDs of the function keys for additional electrical installations

The current switch status of a button is indicated with LEDs next to the relevant function key for the additional electrical installation.

Description	LED
Function off	LED OFF
Function on	LED ON

Operation of the display operating unit

Symbols for numeric keypad

The available inputs and the positions of the keys are shown for inputting digits, **ESC** and **ENTER**.

Keys for the digits 1 to 7 and the **ESC** and **ENTER** keys for inputting the fleet manager password

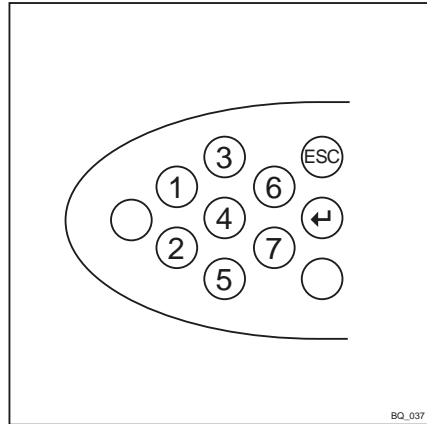

Keys for digits 0 to 9 for inputting the driver PIN (access code) ▷

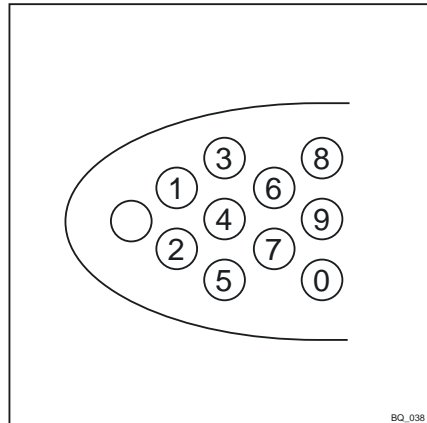

Setting the date or time

- Switch to the "CONFIGURATION" menu; see ⇒ Chapter "Adjusting the displays", P. 4-106.
- Press the drive program key (1) or menu selection key (2) until the option **TIME** appears. Confirm your selection by pressing the Return key (4).

The "TIME" menu appears.

- Press the drive program button (1) or the menu change button (2) until the desired time appears in the display.

As the buttons are held down for longer, the scrolling speed increases in three levels.

- Confirm the time set by pressing the Return key (4).
- Use the arrow key (3) to exit the menu and return to the next higher level.



NOTE

The date is set in a similar manner.

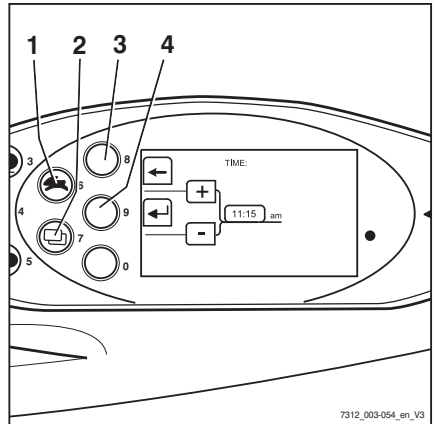

7312_003-054_en_V3

Resetting the daily kilometres and daily operating hours

The daily number of kilometres and daily operating hours displays can be reset to zero:

- Switch to the "CONFIGURATION" menu; see ⇒ Chapter "Adjusting the displays", P. 4-106.
- Press drive program button (1) or menu selection button (2) until the **DAY-KM** option appears. Confirm your selection by pressing the Return key.

The "DAY KM" menu appears.

- Reset the values by pressing the **RES** (4) button.
- Use the arrow key (3) to exit the menu and return to the next higher level.

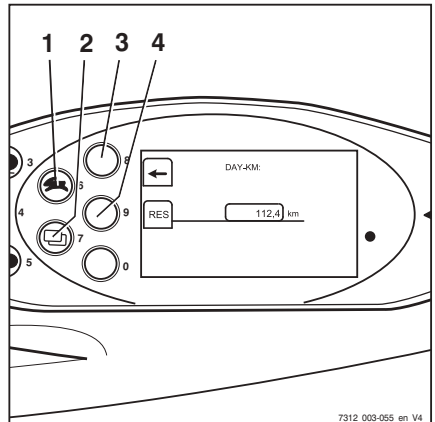

7312_003-055_en_V4

Operation of the display operating unit

NOTE

The daily operating hours are reset in the same manner.

Setting the language

The displays can be shown in additional languages:

- Switch to the "CONFIGURATION" menu; see ⇒ Chapter "Adjusting the displays", P. 4-106.
- Press drive program button (1) or menu selection button (2) until the LANGUAGE option appears. Confirm your selection by pressing Return key(4).

The "LANGUAGE" menu appears.

- Press drive program button (1) or menu change button (2) until the desired language appears in the display.
- Confirm your selection by pressing the Return key (4).
- Use arrow key (3) to exit the menu and return to the next higher level.

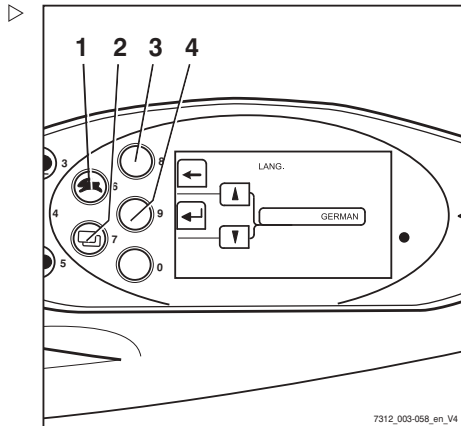

Soft key button for operating various equipment variants

There are two soft key columns available on the display operating unit. With these soft key columns, you can switch the additional functions on and off, e.g. a rotating beacon. The second soft key column is only available if the truck has more than three additional functions.

A grey bar (3) highlights the active soft key column, i.e. the soft keys in this column can be operated. To change the soft key column:

- Briefly press the "Menu change button"(1). The grey bar jumps to the other soft key column. The required soft keys are now active and the functions assigned to them can be switched on and off using the corresponding soft key buttons (2).

i NOTE

In order to shift between the individual menus of the display operating unit, press the "Menu change button" (1) for approx. 1 second.

i NOTE

The functions of the two soft key columns depend on the individual equipment of the truck. Therefore, the soft keys on your display operating unit may vary to those shown here.

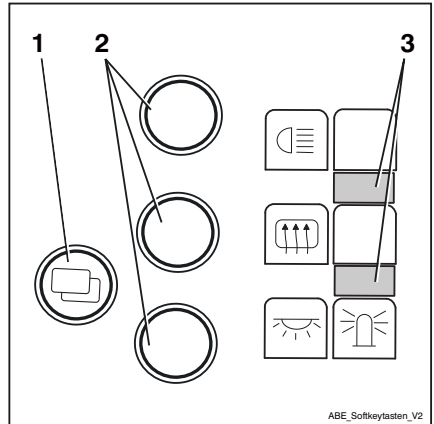

Configuring Blue-Q efficiency mode

The following operating modes can be selected to activate the Blue-Q efficiency mode:

STANDARD

- Blue-Q is turned off whenever the truck is commissioned. The driver can use the Blue-Q button to switch efficiency mode on and off at any time while the truck is being operated

FIXED

- Blue-Q is switched on permanently whenever the truck is commissioned and during truck operation. The driver cannot turn efficiency mode off

FIXED-FLEX

- Blue-Q is turned on whenever the truck is commissioned. The driver can use the Blue-Q button to switch efficiency mode on and off at any time while the truck is being operated

Operation of the display operating unit

- Switch to the CONFIGURATION menu; see ⇒ Chapter "Adjusting the displays", P. 4-106
- Keep pressing the drive programme button (1) or the menu change button (2) until option BLUE Q CONFIGURATION appears.
- Confirm your selection by pressing the Return key (4).

The BLUE-Q CONFIGURATION menu appears.

- Press drive program button (1) or menu change button (2) until the desired efficiency mode appears in the display.
- Confirm the set efficiency mode with Return button (4).
- Use arrow key (3) to exit the menu and return to the next higher level.

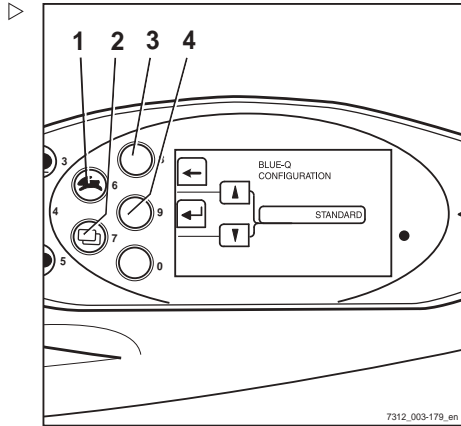

Blue-Q efficiency mode

Functional description

The Blue-Q efficiency mode affects both the drive unit and the activation of the additional consumers, and reduces the truck's energy consumption.

If the efficiency mode has been activated, the acceleration behaviour of the truck changes to make acceleration more moderate.

When travelling at low speeds—normally when manoeuvring—no reduction is noticeable despite the activated efficiency mode. For moderate speeds of at least approx. 7 km/h, acceleration is gentler. Therefore, on distances of up to approx. 40 m, lower speeds are reached than would be the case if the efficiency mode was not activated.

Blue-Q has no influence on:

- Maximum speed
- Climbing capability
- Traction
- Braking characteristics



NOTE

The Blue-Q efficiency mode can be switched on and off in the STANDARD and FIXED-FLEX operating modes. If the FIXED operating mode is configured in the display operating unit, the Blue-Q button has no function and the Blue-Q efficiency mode is switched on permanently; see also chapter "Configuring Blue-Q efficiency mode".

Effects on additional consumers

The following table shows the specific conditions that cause certain auxiliary devices to shutdown when Blue Q is activated. The auxiliary devices available depend on the truck equipment.

Shut-off	Seat switch	Truck stopped	Drive direction
Front working spotlight*	X	X	Backwards > 3 km/h
Rear working spotlight*	X	X	Forwards

Blue-Q efficiency mode

Shut-off	Seat switch	Truck stopped	Drive direction
Top double working spotlight*	X	X	> 3 km/h
Headlight*	X	X	-
Side light	-	-	-
Front wiper	X	X	Backwards > 3 km/h
Rear wiper	X	X	Forwards
Seat heater	X	-	-
Cab heating	X	-	-

*No shutdown for StVZO (Road Traffic Licensing Regulations) equipment.

Switching efficiency mode Blue-Q on and off

 NOTE

The Blue-Q efficiency mode can be switched on and off in the STANDARD and FIXED-FLEX operating modes. If the FIXED operating mode is configured in the display operating unit, the Blue-Q button has no function and the Blue-Q efficiency mode is switched on permanently. For information on configuring the Blue-Q operating modes, see chapter "Configuring Blue Q efficiency mode".

- Press the Blue-Q button (1).

The Blue-Q symbol (2) appears next to the drive programme symbol in the display and operating unit, which means that the Blue-Q efficiency mode is activated.

Pressing the Blue-Q button once again turns the Blue-Q efficiency mode off again.

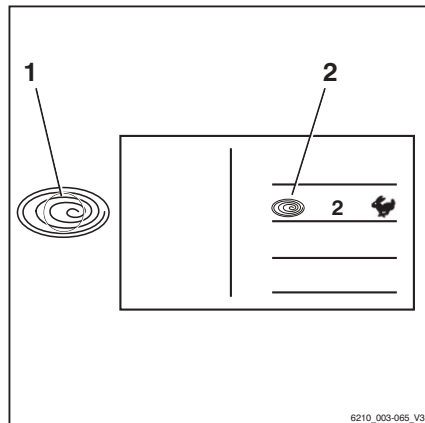

Driving

Safety regulations when driving

Driving conduct

The driver must follow the public rules of the road when driving in company traffic.

The speed must be appropriate to the local conditions.

For example, the driver must drive slowly around corners, in tight passageways, when driving through swing-doors, at blind spots, or on uneven surfaces.

The driver must always maintain a safe braking distance from vehicles and persons in front, and must always have the truck under control. Stopping suddenly, turning quickly and overtaking at dangerous or blind spots must be avoided.

- Initial driving practice must be carried out in an empty space or on a clear roadway.

The following are forbidden during driving:

- Allowing arms and legs to hang outside the truck
- Leaning the body over the outer contour of the truck
- Climbing out of the truck
- Moving the driver's seat
- Adjusting the steering column
- Releasing the seat belt
- Disabling the restraint system
- Raising the load higher than 300 mm above the ground (with the exception of manoeuvring processes during the placement into stock/removal from stock of loads)
- Using electronic devices, for example radios, mobile phones etc.

Driving

⚠ WARNING

The use of multimedia and communication equipment as well as playing these devices at an excessive volume during travel or when handling loads can affect the operator's attention. There is a risk of accident!

- Do not use devices during travel or when handling loads.
- Set the volume so that warning signals can still be heard.

⚠ WARNING

In areas where use of mobile phones is prohibited, use of a mobile phone or radio telephone is not permitted.

- Switch off the devices.

Visibility when driving

The driver must look in the drive direction and have a sufficient view of the driving lane.

Particularly for reverse travel, the driver must be sure that the driving lane is clear.

When transporting goods that impair visibility, the driver must drive the truck in reverse.

If this is not possible, a second person acting as a guide must walk in front of the truck.

In this case the driver must only move at walking pace and with extra care. The truck must be stopped immediately if eye contact with the guide is lost.

Rear-view mirrors are only to be used for observing the road area behind the truck and not for reverse travel. If visual aids (mirror, monitor) are necessary to achieve sufficient visibility, it is necessary to practise using them. For reverse travel using visual aids, extra care should be taken.

When using attachments, special conditions apply; see the chapter entitled "Fitting attachments".

Any glass (variant, e.g. windscreen) and mirrors must always be clean and free of ice.

Driveways

Dimensions of roadways and aisle widths

The following dimensions and aisle width requirements apply under the specified conditions to ensure safe manoeuvring. In each case, a check must be performed to determine whether a larger aisle width is necessary, e.g. in the case of deviating load dimensions, attachments or lift masts.

Within the EU, Directive 89/654/EEC (minimum safety and health requirements for the workplace) must be observed. The respective national guidelines apply for areas outside of the EU.

The required aisle widths depend on the dimensions of the load.

For pallets, these are:

Model	Type	Aisle width [mm]	
		With pallet 1000x1200 crosswise	With pallet 800x1200 lengthwise
RX70-16	7311	3523	3727
	7314		
RX70-18	7312	3557	3762
	7315		
RX70-20	7313	3603	3810
	7316		

The truck may only be used on roadways that do not have excessively sharp bends, excessively steep gradients or excessively narrow or low entrances.

Driving

Driving on ascending and descending gradients**▲ CAUTION**

It is not permitted to drive on long ascending and descending gradients greater than 15% due to the specified minimum braking and stability values.

The climbing capability values given below only apply to overcoming obstacles on the roadway and to short differences in level, e.g. ramps.

- Before driving on long ascending and descending gradients greater than 15%, consult the authorised service centre.

The truck may be driven on the following ascending and descending gradients:

Model	Type	Maximum gradient [%]	
		With load	There is no load on the truck
RX70-16	7311	27.0	28.0
	7314		
RX70-18	7312	26.0	
	7315		
RX70-20	7313		
	7316		

The upwards and downwards gradients must not exceed the maximum gradients above and must feature a rough surface.

The top and bottom of the gradient must feature smooth and gradual transitions to prevent the load from falling to the ground or the truck being damaged.

Warning in case components project beyond the truck contour

Trucks are often required to drive through very narrow or very low spaces such as aisles or containers. The trucks are dimensioned for this purpose. However, movable parts may project beyond the truck contour and

be damaged or torn off. Examples of such components include:

- A folding roof panel in the driver's cab
- Cab doors
- Folding LPG cylinders

Condition of the roadways

Roadways must be sufficiently firm, level and free from dirt and fallen objects.

Drainage channels, level crossings and similar obstacles must be evened out and, if necessary, ramps must be provided so that trucks can drive over these obstacles with as few bumps as possible.

Note the load capacity of manhole covers, drain covers etc.

There must be sufficient distance between the highest points of the truck or the load and the fixed elements of the surrounding area. The height is based on the overall height of the lift mast and the dimensions of the load; see the chapter entitled "Technical data".

Rules for roadways and the working area

It is only permitted to drive on routes authorised for traffic by the operating company or its representatives. Traffic routes must be free of obstacles. The load may only be set down and stored in the designated locations. The operating company and its representatives must ensure that unauthorised third parties do not enter the working area.



NOTE

Please note the definition of "operating company" in the sense of responsible persons!

Hazard areas

Hazard areas on roadways must be marked by standard traffic signs or, if necessary, by additional warning signs.

Driving

Setting the drive programs

The driving and braking characteristics of the drive can be set on the display and operating unit.

- Push the drive program button (1) repeatedly until the number of the required drive program appears on the drive program display (2).

Drive programs 1-5 are available.

The basic principle is that the higher the drive program number is, the greater the driving dynamics.

The following drive programs are possible:

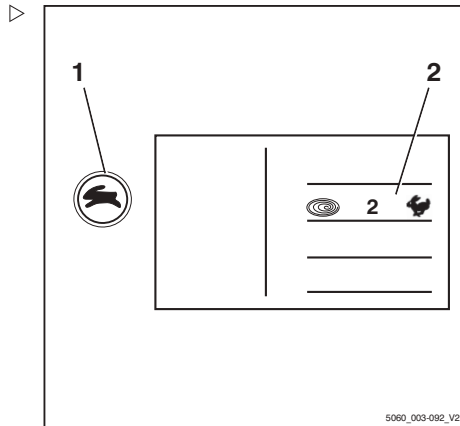

Drive program	1	2	3	4	5
Speed (km/h)	22	22	22	22	22
Acceleration (%) (forwards/backwards)	50	100	120	140	160
Deceleration (%) (forwards/backwards)	50	100	120	140	160
Reversing (%) (forwards/backwards)	50	100	120	140	160
Brake retardation (%) (electric brake booster)	60	70	80	90	100

Selecting the drive direction

The desired drive direction of the truck must be selected using the drive direction switch before attempting to drive. The method of actuating the drive direction switch depends on the operating devices included in the truck's equipment.

Possible equipment variants include:

- Mini-lever
- Joystick 4Plus
- Fingertip switch
- Mini-console



The drive direction can also be changed during travel. Your foot can remain on the accelerator pedal while doing so. The truck is

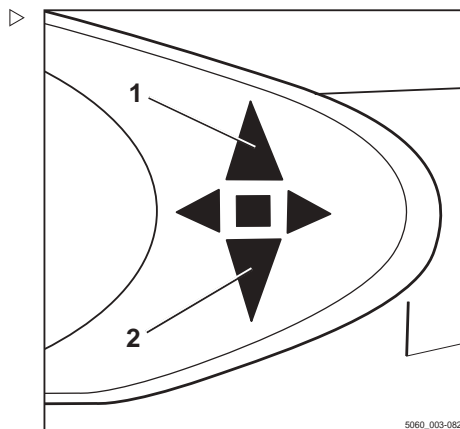

then decelerated and accelerated again in the opposite direction (reversing).

The indicator for the selected drive direction ("forwards" (1) or "reverse" (2)) lights up on the display and operating unit.

Neutral position

If the truck is stopped for an extended period, select the neutral position to prevent the truck from suddenly starting if the accelerator pedal is inadvertently pressed.

- Briefly select the drive direction switch for the direction opposite to the current direction.

The drive direction indicator on the display and operating unit goes out.

NOTE

When the seat is vacated, the drive direction switch is set to "Neutral". To drive, the drive direction switch must be actuated again.

Actuating the drive direction switch, mini-lever version

- For the "forwards" drive direction, push the cross lever (1) forwards
- For the "backwards" drive direction, push the cross lever backwards

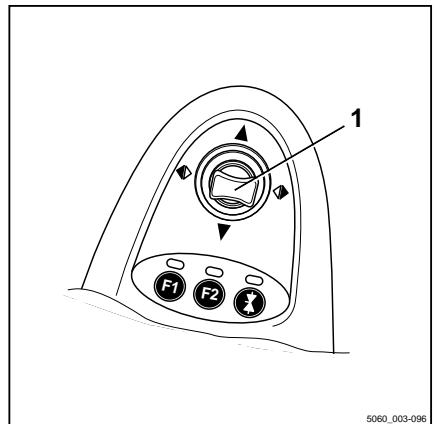

Driving

Actuating the vertical rocker switch for the "drive direction", joystick 4Plus version

- For the "forwards" drive direction, push the vertical rocker button for the "drive direction"(1) upwards (A).
- For the "reverse" drive direction, push the vertical rocker button for the "drive direction"(1) downwards (B).

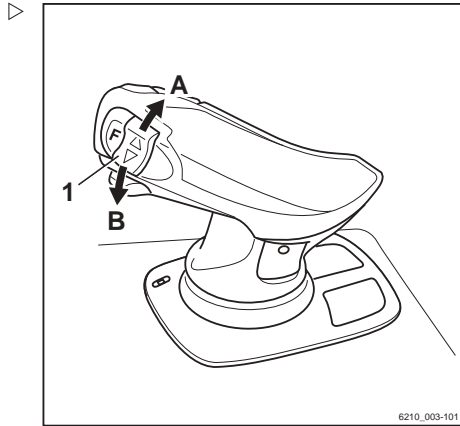

6210_003-101

Actuating the drive direction switch, fingertip version

- For the "forwards" drive direction, push the drive direction switch (1) forwards
- For the "backwards" drive direction, push the drive direction switch backwards

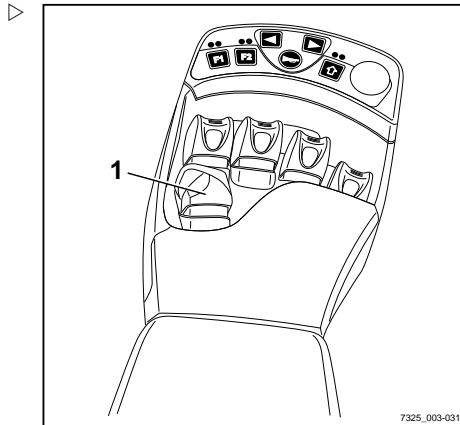

7325_003-031

Actuating the drive direction switch, mini-console version

- For the "forwards" drive direction, push the drive direction switch (1) forwards.
- For the "backwards" drive direction, push the drive direction switch to the rear.



NOTE

Alternatively, the drive direction can also be selected using the drive direction switches on the operating devices.

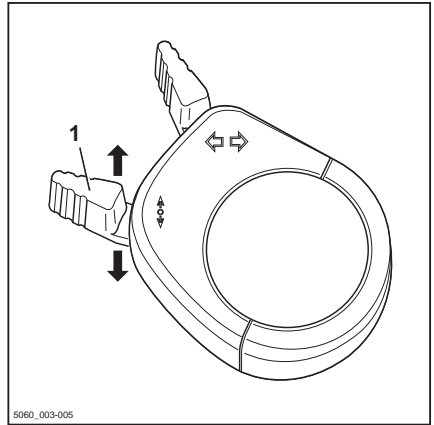

Starting to drive

⚠ DANGER

Being trapped under a rolling or tipping truck could cause fatal injuries.

- Sit down on the driver's seat.
- Fasten the seat belt.
- Activate the available restraint systems.

Observe the information in the chapter entitled Safety regulations when driving.

The driver's seat is equipped with a seat switch. This checks whether the driver's seat is occupied. If it is not occupied or in the case of malfunction of the seat switch, the truck cannot be moved and all lifting functions are locked. In this situation, the message SEAT SWITCH appears in the operating unit display.

- Lift the fork carriage until the necessary ground clearance is achieved.
- Tilt the lift mast backwards.
- Release the parking brake.
- Select the desired drive direction.

Driving

The indicator for the selected drive direction ("forwards" (1) or "backwards" (2)) lights up on the display and operating unit.

NOTE

Depending on the equipment, an acoustic signal (variant) may sound a warning during reverse travel, the warning light (variant) may light up or the hazard warning system (variant) may flash.

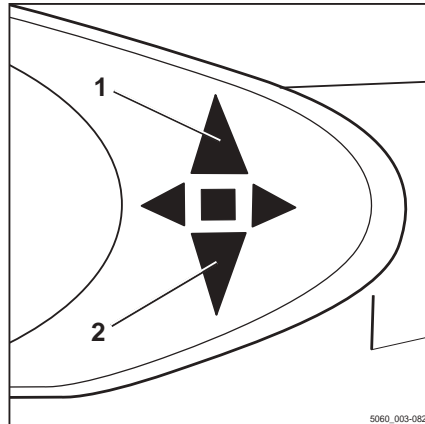

- Press the accelerator pedal (3).

The truck will travel in the selected drive direction. The speed is controlled by the accelerator pedal position. When the accelerator pedal is released, the truck decelerates.

NOTE

The truck can briefly be stopped on upward or downward gradients without actuating the parking brake (electric brake). The truck begins to creep downhill slowly.

DANGER

Risk of accident due to brake failure!

The electric brake only functions while the key switch is switched on, the emergency off switch (variant) has not been actuated and the parking brake is released.

- Use the brake pedal if the electrical brake malfunctions
- Do not leave the truck without actuating the parking brake!

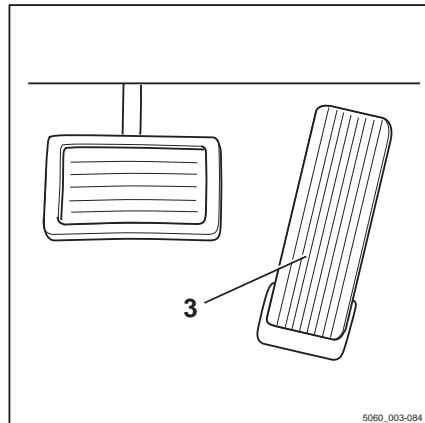

Changing the drive direction

- Remove foot from accelerator pedal.
- Select the desired drive direction.
- Press the accelerator pedal.

The truck will travel in the selected drive direction.

i NOTE

The drive direction can also be changed during travel. Your foot can remain on the accelerator pedal. The truck decelerates and is then accelerated again in the opposite direction (reversing).

i NOTE

In the event of an electrical fault with the accelerator the drive unit is shut down. The electrical brake (service brake) causes the truck to decelerate. The truck cannot be driven again until the accelerator pedal has been released and then actuated again, provided the electrical fault has been corrected. If the truck still won't operate, park it securely and contact your service centre.

Starting drive mode, dual-pedal version (variant)

⚠ DANGER

Being trapped under a rolling or tipping truck could cause fatal injuries.

- Sit down on the driver's seat.
- Fasten the seat belt.
- Activate the available restraint systems.

Observe the information in the chapter entitled Safety regulations when driving.

The driver's seat is equipped with a seat switch. This checks whether the driver's seat is occupied. If it is not occupied or in the case of malfunction of the seat switch, the truck cannot be moved and all lifting functions are locked. In this situation, the message SEAT SWITCH appears in the operating unit display.

- Lift the fork carriage until the necessary ground clearance is achieved.
- Tilt the lift mast backwards.
- Release the parking brake.

Driving

- Press the right accelerator pedal (1) to drive "forwards" and press the left accelerator pedal (2) to drive "backwards".

i NOTE

In the dual pedal version, any drive direction switches on the operating devices have no effect.

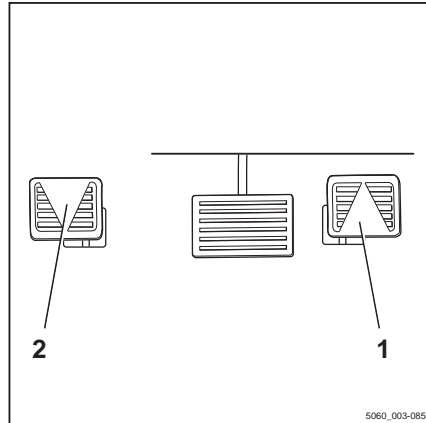

- The indicator for the selected drive direction ("forwards" (3) or "backwards" (4)) lights up on the display and operating unit.

i NOTE

Depending on the equipment, an acoustic signal (variant) may sound a warning during reverse travel, the warning light (variant) may light up or the hazard warning system (variant) may flash.

The truck will travel in the selected drive direction. The speed is controlled by the accelerator pedal position. When the accelerator pedal is released, the truck decelerates.

i NOTE

The truck can briefly be stopped on upward or downward gradients without actuating the parking brake (electric brake). The truck begins to creep downhill slowly.

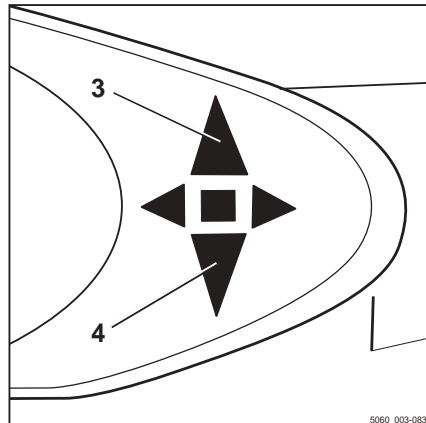

⚠ DANGER**Risk of accident!**

The electric brake only functions while the key switch is switched on, the emergency off switch (variant) has not been actuated and the parking brake is released.

- Use the brake pedal if the electric brake malfunctions.
 - Do not leave the truck without actuating the parking brake!
-

Changing the drive direction

- Remove foot from actuated accelerator pedal.
- Actuate the accelerator pedal for the other direction.

The truck will travel in the selected drive direction.

**NOTE**

In the event of an electrical fault with the accelerator the drive unit is shut down. The electrical brake (service brake) causes the truck to decelerate. The truck cannot be driven again until the accelerator pedal has been released and then actuated again, provided the electrical fault has been corrected. If the truck still won't operate, park it securely and contact your service centre.

Driving

Operating the service brake

The electric brake converts the acceleration energy of the truck into electrical energy. This causes the truck to decelerate.

In addition, the truck can be braked using the service brake:

- Press the brake pedal (2).

In the first section of the brake pedal's travel, only the regenerative braking takes effect. As the pedal is depressed further, the service brake is also activated and acts on the drive wheels.

⚠ DANGER

Risk of accident!

If the service brake fails, the truck cannot brake sufficiently.

- Bring the truck to a standstill by applying the parking brake.
- Do not operate the truck again until the service brake has been repaired.

⚠ DANGER

Risk of tipping and risk of slipping!

The braking distance of the truck depends on the weather conditions and the level of contamination on the roadway. The braking distance increases with the square of the speed. There is a danger that the truck could slip or overturn.

- Adapt your driving and braking style to suit the weather conditions and the level of contamination on the roadway.
 - Always choose a driving speed that will provide a sufficient stopping distance.
-
- Brake the truck by releasing the accelerator pedal (1).
 - If the braking effect is inadequate, brake using the service brake (2) as well.

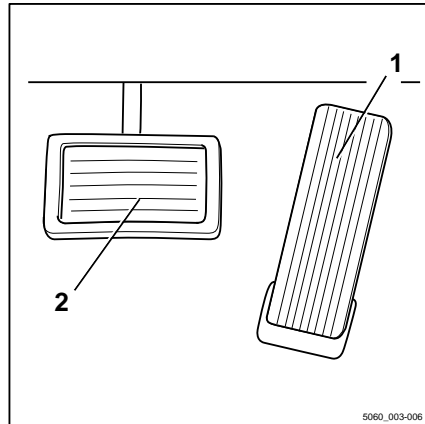

5060_003-006

Zero braking (variant)

DANGER

Risk of accident!

Trucks with zero braking (variant) are not braked when the accelerator pedal is released.

- Bring the truck to a standstill by actuating the brake pedal.

If your truck features the zero braking equipment variant, the electric brake function is disabled. Taking your foot off the accelerator pedal does not brake the truck.

In this case, the truck can only be slowed by applying the service brake via the brake pedal.

Parking brake

Operation of the parking brake depends on which parking brake the truck is fitted with.

Possible equipment variants are as follows:

- Mechanical parking brake; see ⇒ Chapter "Actuating the mechanical parking brake", P. 4-131
- Electric parking brake; see ⇒ Chapter "Actuating the electric parking brake", P. 4-133

Actuating the mechanical parking brake

DANGER

There is a risk of being run over if the truck rolls away, and therefore a danger to life.

- The truck must not be parked on a slope.
- In emergencies, secure with wedges on the side facing downhill.
- Only leave the truck when the parking brake is applied.

NOTE

Once the parking brake is released, the previously selected drive direction is retained and is shown on the drive direction indicator.

Driving

i NOTE

If you operate the accelerator pedal while the parking brake is applied and a drive direction is selected, the message PARKING BRAKE appears in the display.

Apply the parking brake

- Pull the parking brake lever (1) down fully and release.

The parking brake lever swivels back half the distance into the middle position automatically.

The parking brake is engaged and the wheels are blocked. Driving is no longer possible. The drive direction indicator (2) on the display and operating unit goes out.

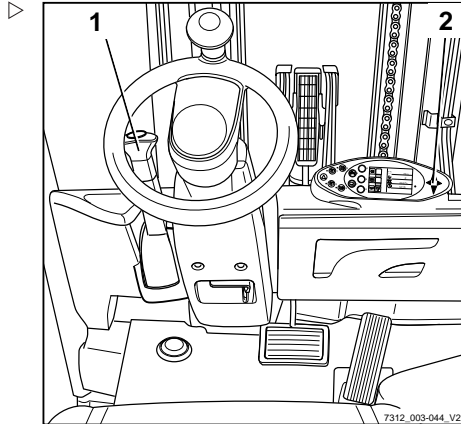
**Releasing the parking brake**

- Pull the parking brake lever (1) down fully out of the middle position.
- In the lower lever position, pull out the lever knob and then guide the parking brake lever up fully.

i NOTE

The parking brake lever swivels to the upper position automatically by means of spring force and should be guided only lightly by hand. If the adjustment is stiff, notify the authorised service centre.

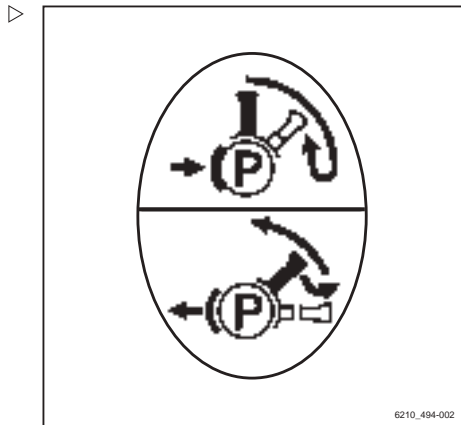

Actuating the electric parking brake

The electric parking brake helps the driver to park the truck safely thanks to the simple actuation of the push button (1) and the additional automatic functions. Despite these automatic aids, the driver is always responsible for parking the truck safely. The safety information about safe parking applies.



⚠ DANGER

There is a risk of being run over if the truck rolls away and therefore a danger to life.

- The truck should not be parked on a slope.
- In emergencies, secure with wedges on the side facing downhill.
- Only leave the truck if the parking brake is applied.

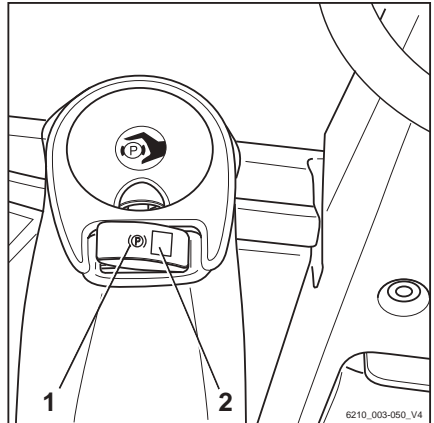

i NOTE

To electrically activate the parking brake, the battery male connector must be connected and the key switch must be switched on.

Driving

Functions at truck standstill

Actuation by the driver

- Press push button (1).

The parking brake will audibly engage and the LED (2) illuminates with a steady light.

Actuation triggered automatically

Cause	Effect
When the driver leaves the driver's seat:	After a short waiting period, the parking brake will audibly engage and the LED (2) will illuminate with a steady light.
When the accelerator pedal is released:	After a short waiting period, the parking brake will audibly engage and the LED (2) will illuminate with a steady light. The truck is held on a gradient by the traction motor until the parking brake is applied.
When the key switch is turned off:	The parking brake will audibly engage immediately and the LED (2) will illuminate briefly with a steady light until the control units switch off.
If the emergency off switch (variant) is actuated, following the emergency off function:	The parking brake is applied.

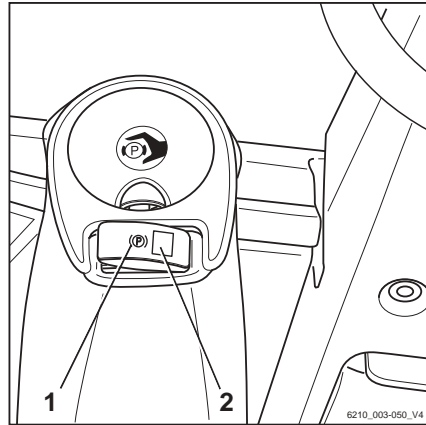

If the electric parking brake is applied, the **PARKING BRAKE ACTIVE** message appears in the display for 5 seconds.



Releasing the parking brake by pressing the button



NOTE

When the truck is ready for operation, the electric parking brake can be released at any time by pressing the button.

- Sit down on the driver's seat.
- Press push button (1).

The parking brake will audibly release and the LED (2) will go out.

Releasing the parking brake by starting to drive

NOTE

The electric parking brake can be released by starting to drive only if the electric parking brake is applied automatically by releasing the accelerator pedal or vacating the driver's seat.

- Sit down on the driver's seat.
- Select the drive direction (single-pedal version only).
- Actuate the accelerator pedal.

The parking brake will audibly release and the LED (2) will go out.

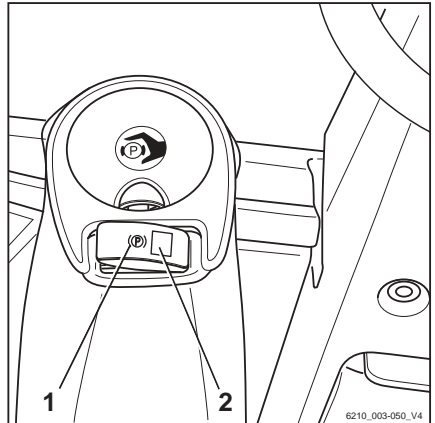

Driving

If the parking brake has not been applied by the accelerator pedal being released or the driver's seat being vacated, then it is not possible to drive the truck until the parking brake has been released by pressing the button. The `RELEASE PARKING BRAKE` message appears in the display.

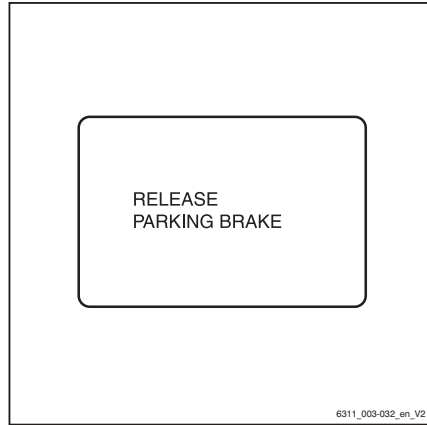

Functions available when the truck is moving

Actuation by the driver

- Press push button (1).

The truck is braked moderately. Depending on the situation, it is possible to drive again after the button has been released. If the truck is at a standstill, the parking brake audibly engages and the LED (2) illuminates with a steady light.

Actuation triggered automatically

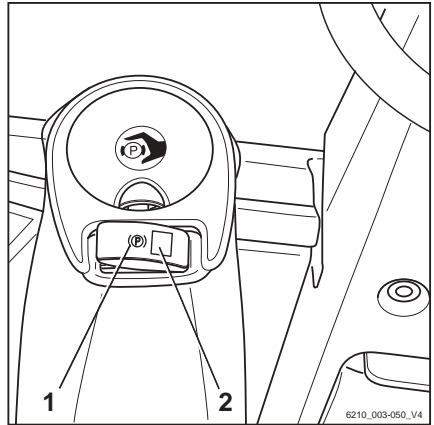

Cause	Effect
When the driver leaves the driver's seat:	After a short wait, the truck rolls to a stop or decelerates moderately. If the truck is at a standstill, the parking brake audibly engages and the LED (2) illuminates with a steady light.
When the key switch is turned off:	The truck will roll to a stop. If the truck is at a standstill, the parking brake audibly engages and the LED (2) illuminates with a steady light until the control units switch off.
If the emergency off switch (variant) is actuated, following the emergency off function:	The truck will roll to a stop. If the truck is at a standstill, the parking brake audibly engages and the LED (2) illuminates briefly with a steady light.
Automatic braking:	With the drive deactivated and the seat not occupied, or if the truck being accelerated heavily, the parking brake is applied with moderate braking force.

Driving

Steering

⚠ DANGER

If the hydraulics fail, there is a risk of accident as the steering characteristics have changed.

– Do not operate the truck if it has a defective steering system.

– Steer the truck by turning the steering wheel (1) accordingly.

Turning the steering wheel in the direction of arrow (A) steers the truck in drive direction (A).

Turning the steering wheel in the direction of arrow (B) steers the truck in drive direction (B).

For turning radius information, see ⇒ Chapter "VDI datasheet for RX70-16, RX70-18 and RX70-20", P. 6-350.

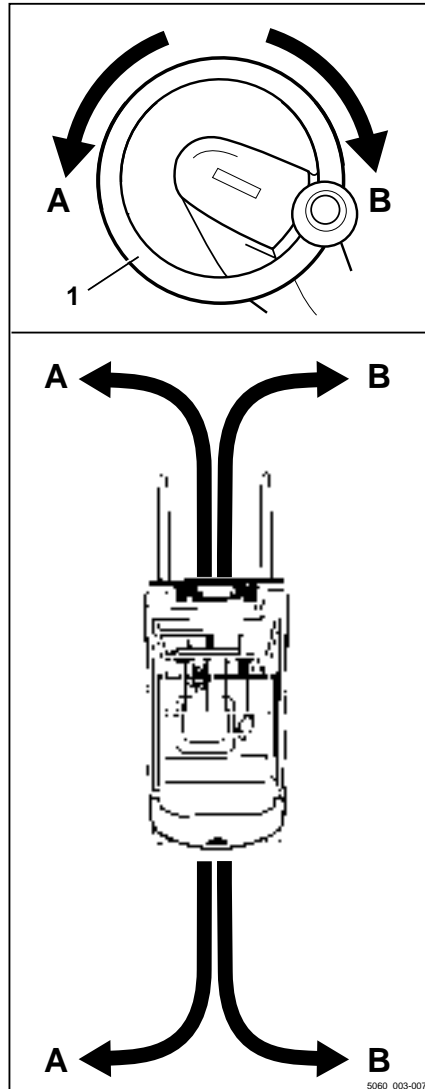

Driving on ascending and descending gradients

⚠ DANGER

Danger to life!

Driving on ascending and descending gradients carries special dangers!

- Always follow the instructions below.
-
- On ascending and descending gradients, the load must be carried facing uphill.
 - It is only permitted to drive on ascending and descending gradients that are marked as traffic routes and that can be used safely.
 - Ensure that the ground to be traversed is clean and provides a good grip.
 - Do not turn on ascending and descending gradients.
 - Do not drive onto or along ascending and descending gradients at an angle.
 - Do not park the truck on ascending or descending gradients.
 - In case of emergency, secure the truck with wedges so that the truck does not roll away.
 - Reduce the driving speed on descending gradients.

It is not permitted to drive on long ascending and descending gradients greater than 15% due to the specified minimum braking and stability values.

- Before driving on ascending and descending gradients greater than 15%, consult the authorised service centre.

The process of placing loads into stock and removing loads from stock while on an ascending or descending gradient is not permitted!

- Always place loads into stock and remove loads from stock on a horizontal plane.



Driving

Reducing speed with a raised load (variant)

This function (variant) reduces the speed of the truck with a raised load.

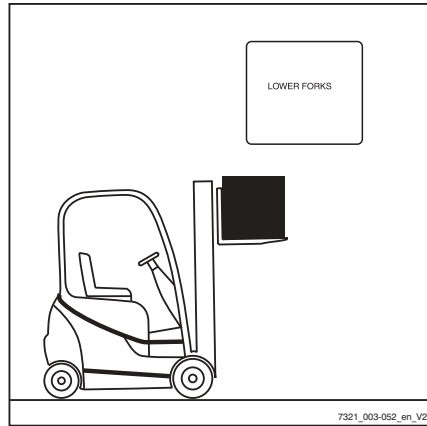

Automatic shut-off of the internal combustion engine (variant)

The truck is equipped with an automatic shut-off function that shuts off the internal combustion engine when certain conditions apply simultaneously after a preset waiting time has elapsed.

The message **CUTOUT MODE** appears in the display.

Conditions that apply simultaneously:

- The truck is stationary.
- The parking brake is applied.
- The driver's seat is not occupied.
- Particle filter regeneration is not in progress.
- There are no consumers switched on that require a significant amount of energy, such as the air conditioning.

The waiting time only starts when all conditions apply simultaneously. If one of the conditions is no longer fulfilled, the waiting time stops and is restored to the preset value.

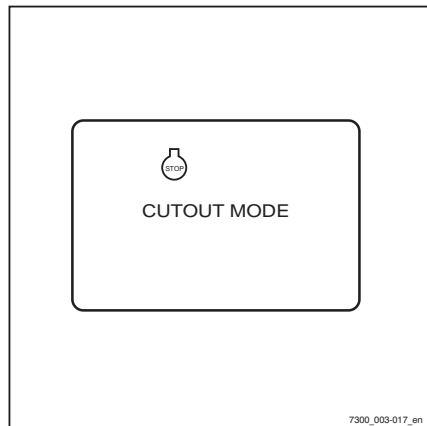

NOTE

The waiting time is set to 120 seconds at the factory, but can be changed at a later date.

- *Contact the authorised service centre.*

Parking

Parking the truck securely and switching it off



⚠ DANGER

Risk of fatal injury from being run over if the truck rolls away!

- The truck must not be parked on a slope.
- In emergencies, secure the truck using wedges on the side facing downhill.
- Only leave the truck when the parking brake has been applied.

⚠ DANGER

There is a risk of fatal injury from a falling load or parts of the truck being lowered!

- Lower the load fully before leaving the truck.
- Apply the parking brake.
- Lower the fork carriage to the ground.
- Tilt the lift mast forwards until the tips of the fork arms rest on the ground.
- If attachments (variant) are fitted, retract the working cylinders; see the chapter entitled "General instructions for controlling attachments".
- Take your foot off the accelerator pedal and allow the engine to continue idling for a short while.
- Turn the switch key to the left and remove it.

i NOTE

Switch keys, FleetManager cards (variant), FleetManager transponder chips (variant) and the PIN code for access authorisation (variant) must not be handed over to other persons unless explicit instructions to this effect have been given.



5060_003-130

Parking

Wheel chock (variant)

The wheel chock (variant) is used to prevent the truck from rolling away on a slope.

- Lift handle (2) on the support mounting.
- Remove wheel chock (1) from the support mounting.
- Push the wheel chock under a front axle wheel on the side facing the downhill slope.

 NOTE

After use, return the wheel chock to the support mounting and press the handle (2) down again.

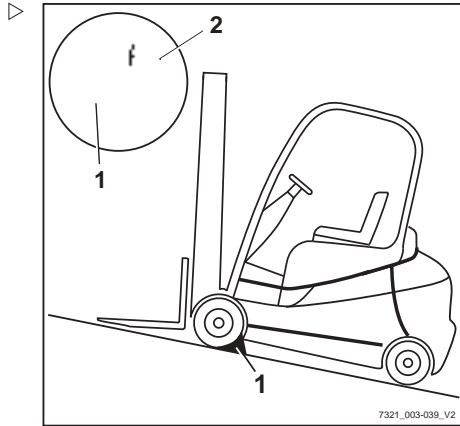

Lifting

Lifting system variants

The movement of the fork carriage and the lift mast heavily depends on the following equipment:

- The lift mast with which the truck is equipped, see ⇒ Chapter "Types of lift mast", P. 4-148
- The operating device with which the hydraulic functions are controlled, see ⇒ Chapter "Lifting system operating devices", P. 4-152

Regardless of the equipment variants of the truck, the basic specifications and procedures must be complied with, see ⇒ Chapter "Safety regulations when handling loads", P. 4-165.

Automatic lift cut out (variant)

Description:

The automatic lift cut out (variant) means that the load cannot be lifted above a preset height. This function uses a sensor that is welded on at the factory at the required lift mast limit height. Once attached, the height cannot be easily changed.

Application:

- If the ceiling of the building is lower than the maximum lift height of the truck, this variant can prevent the lift mast from accidentally hitting the ceiling, which can result in damage.
- If the truck is frequently used at a particular height, the work is simplified by the automatic lift cut out at this height.

NOTE

If a load is lifted very quickly, the fork carriage and load are moved approximately 15 cm above the position of the sensor due to inertia. This deviation is already taken into consideration at the factory when determining the position of the sensor.

Lifting

Overriding and reactivating the automatic lift cut out

If a load needs to be lifted to the truck's maximum lift height and the automatic lift cut out function is not required, it is possible to override the lift cut out. It is automatically reactivated when the truck is switched off and back on again.

To override the automatic lift cut out:

- Press the "F1"(1) button on the display operating unit. The automatic lift cut out is now overridden and a load can be lifted to the truck's maximum lift height.

To switch the automatic lift cut out back on:

- Press the "F1"(1) button again.

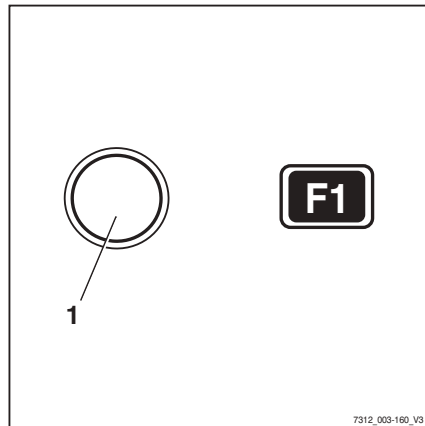
**Lift mast vertical position (variant)****Description**

If the truck is equipped with the "lift mast vertical position" comfort feature (variant), the driver can put down goods, such as paper rolls, vertically with precision and thus avoid damage when unloading. The tilt cylinders run into the end stops gently to prevent hard vibrations and impacts. Oscillating motions of the truck are minimised, thus increasing work safety. The lift mast vertical position reduces wear on various components and therefore reduces repair costs.

⚠ CAUTION

Risk of damage to property due to the lift mast colliding with racks or other objects!

- Before using the "lift mast vertical position" comfort feature, position the truck at a sufficient distance from racks and other objects.

The "lift mast vertical position" comfort feature consists of the following individual functions:

- Display of the "lift mast vertical position"
- Automatic approach towards the "lift mast vertical position"
- Gentle running-in to the end stops

The "lift mast vertical position" comfort feature is only available as a variant if the truck is equipped with one of the following operating devices:

- Double mini-lever (1)
- Triple mini-lever (2)
- Quadruple mini-lever (3)
- Fingertip (4)
- Joystick 4Plus (5)

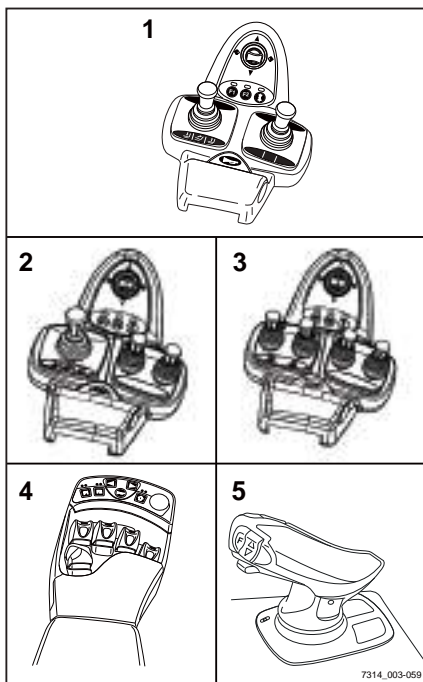

Lifting

Display of the "lift mast vertical position" ▷

The driver can see the mast tilt on the display and operating unit screen. The bar in the display shows the current mast tilt relative to the "lift mast vertical position". The arrow above the bar marks the vertical position of the lift mast.

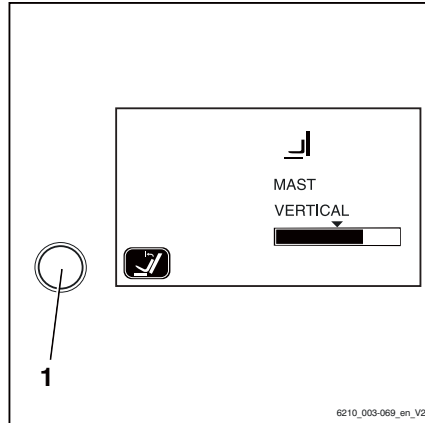
**Automatic approach towards the "lift mast vertical position"**

- Switch on the "lift mast vertical position" comfort feature via the button (1) on the display and operating unit.
- Tilt the lift mast forwards using the corresponding operating device. The lift mast stops automatically as soon as the pre-selected setting is reached for the "lift mast vertical position".

If the comfort feature is switched off, the lift mast tilts forwards past the "lift mast vertical position" without stopping.

If the lift mast is tilted backwards, it moves past the "lift mast vertical position" without stopping, regardless of whether the comfort feature is switched on or not.

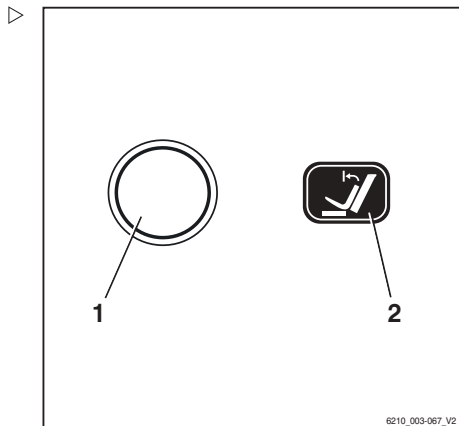
**Gentle running-in to the end stops**

The lift mast is braked gently at the end of the tilt range. This prevents the lift mast from stopping harshly in the end position and reduces severe oscillating motions of the truck.

Tilting the lift mast forwards with the "lift mast vertical position"

- Actuate the button (1) to switch on the "lift mast vertical position" comfort feature; the function display (2) in the display shows the activated status.
- Tilt the lift mast forwards.

NOTE

The way in which the lifting system is operated depends on the operating devices included in the truck's equipment; see the chapter entitled "Lifting system operating devices".

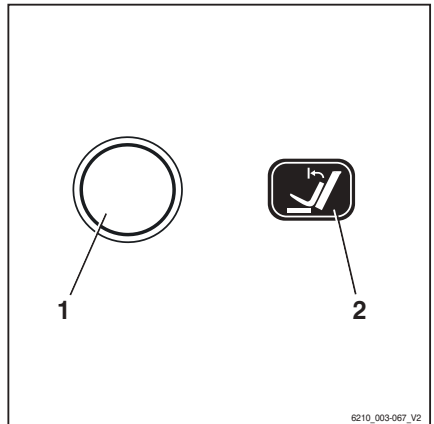

The lift mast is tilted forwards and stops as soon as the vertical position is reached. The arrow above the bar shown on the screen of the display and operating unit represents the "lift mast vertical position".

Tilting the lift mast forwards beyond the vertical position:

- Release the operating device for tilting and actuate again.

The lift mast is tilted beyond the vertical position up to the end stop. The current mast tilt is shown in the display and operating unit.

- To deactivate the "lift mast vertical position", actuate the button (1) again.

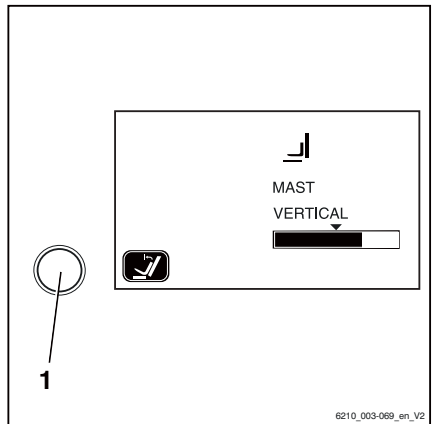

Tilting the lift mast backwards with the "lift mast vertical position"

- Tilt the lift mast backwards.

The lift mast is tilted backwards without stopping in the vertical position.

Lifting

Possible restrictions on the "lift mast vertical position"

In some circumstances, the lift mast cannot move exactly into the preset vertical position.

Possible causes include:

- Uneven ground
- Bent fork
- Bent attachment
- Worn tyres
- Severely deformed lift mast

The vertical position can be corrected by tilting the lift mast using the relevant operating device. If the vertical position has to be corrected frequently, the "lift mast vertical position" should be calibrated.

Calibrating the "lift mast vertical position" ▷

- Set the lift mast to the required position.
- Press and hold the button (1) for the "lift mast vertical position" for at least five seconds.

The message "? VERTICAL POSITION" will appear on the display.

Storing the mast position:

- Press the drive program selector button (3).

The current mast position is stored.

Cancelling calibration:

- Press the menu change button (2).

The calibration is cancelled.

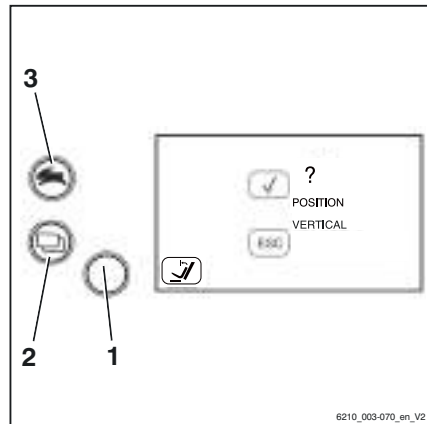

Types of lift mast

One of the following lift masts may be installed in the truck:

Telescopic mast

During lifting, the lift mast rises over the outer lift cylinders, bringing the fork carriage with it via the chains (fork carriage rises twice as fast as the inner lift mast). The top edge (1) of the inner lift mast can therefore be higher than the fork carriage.

⚠ DANGER

Risk of accident due to collision of the lift mast or load with low ceilings or entrances.

- Note that the inner lift mast or load may be higher than the fork carriage.
- Note the heights of ceilings and entrances.

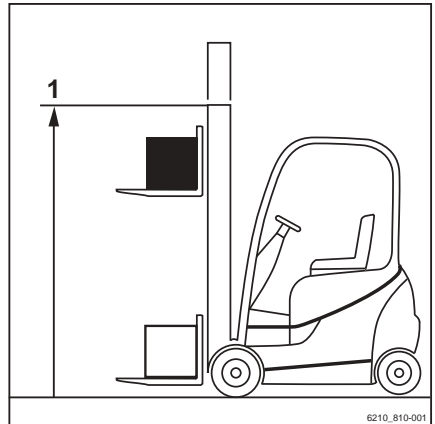

Hi-Lo lift mast (variant)

During lifting, the inner lift cylinder moves up to free lift (3), and then the outer lift cylinders raise the inner lift mast up to the max. height (2).

i NOTE

When lifting above the free lift, the fork carriage always remains at the upper edge of the extending lift mast.

⚠ DANGER

Risk of accident due to collision of the lift mast or load with low ceilings or entrances.

- Note that the inner lift mast or load may be higher than the fork carriage.
- Note the heights of ceilings and entrances.

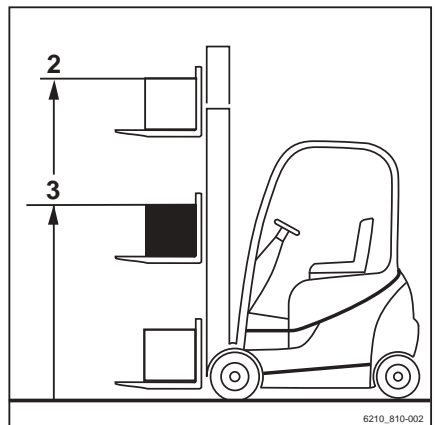

Lifting

Triplex lift mast (variant)

During lifting, the inner lift cylinder moves up to free lift (3), and then the outer lift cylinders raise the inner lift mast up to the max. height (2).

⚠ DANGER

Risk of accident due to collision of the lift mast or load with low ceilings or entrances.

- Note that the inner lift mast or load may be higher than the fork carriage.
- Note the heights of ceilings and entrances.

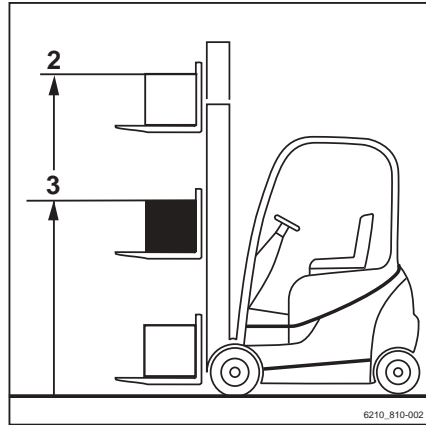
**Malfunctions during lifting mode****Incorrect extension sequence****⚠ DANGER****Risk of accidents!**

In the case of Hi-Lo lift masts (variant) and triplex lift masts (variant), an incorrect extension sequence may occur, i.e. the inner lift mast may extend before the free lift is complete. As a result, the overall height is exceeded and damage may occur in passageways or from low ceilings.

An incorrect extension sequence may, for instance, result from:

- The hydraulic oil temperature being too low.
 - Blocking of the fork carriage in the inner lift mast.
 - Blocking of the free lift cylinder.
 - Blocking of the chain roller on the free lift cylinder.
- If the hydraulic oil temperature is too low, slowly actuate the lift mast functions several times in order to raise the oil temperature.

In the event that the fork carriage is blocked in the inner lift mast, or the free lift cylinder or chain roller are blocked, the cause of the blockage must be eliminated before resuming work.

- Notify your service centre

Load chains not under tension

DANGER

Danger caused by a falling load!

- Make sure that the chain(s) does (do) not become slack when lowering the load.

Slack chains can, for instance, result from:

- Resting the fork carriage or the load on the racking.
- Fork carriage rollers blocking in the lift mast due to contamination.
- If the fork carriage or the load comes to an unexpected stop, lift the fork carriage until the chains are under tension again and lower the load at another suitable location.
- If the fork carriage rollers in the lift mast become blocked due to contamination, lift the fork carriage until the chains are under tension again. Remove the contamination before resuming work.

WARNING

Risk of injury!

- Observe the safety regulations for working on the lift mast, see the chapter entitled "Working at the front of the truck".

Hydraulic blocking function

The hydraulic blocking function ensures that all the functions of the working hydraulics are disabled whenever the seat switch in the driver's seat is unloaded.

If the driver stands up from the driver's seat, the blocking function prevents the hydraulic functions that:

- Lift the load
- Lower the load
- Tilt the lift mast
- Additional functions

Releasing the block on the hydraulics

Proceed as follows to release the block on the hydraulics:

Lifting

- Sit down on the driver's seat.

All the relevant functions of the working hydraulics will be available again.



NOTE

If it is not possible to release the block on the hydraulics when the load is raised because of a technical fault, the load must be lowered using the "emergency lowering" mechanism before any further action is taken. Do not operate the truck again until the fault has been rectified by the authorised service centre.

Lifting system operating devices

The method of operating the lifting system depends on the operating devices included in the truck's equipment.

Possible equipment variants include:

- **Double mini-lever**
- **Triple mini-lever**
- **Quadruple mini-lever**
- **Joystick 4Plus**
- **Fingertip switch**

- The following information must be observed regardless of the equipment variant:

DANGER

Reaching into or climbing between moving parts of the truck (e.g. lift mast, sideshifts, working equipment, load carrying devices etc.) can lead to serious injury or death and is therefore prohibited.

- Observe the safety regulations for handling loads.
 - Only operate the lifting system from the driver's seat.
-

Controlling the lifting system using a double mini-lever

⚠ DANGER

Reaching into or climbing between moving parts of the truck (e.g. lift mast, sideshifts, working equipment, load carrying devices etc.) can lead to serious injury or death and is therefore prohibited.

- Observe the safety regulations for handling loads.
- Operate the lifting system from the driver's seat only.

Lifting/lowering the fork carriage

To lift the fork carriage:

- Move the "lift mast" 360° lever (1) in the direction of arrow (B).

To lower the fork carriage:

- Move the "lift mast" 360° lever (1) in the direction of arrow (A).

Tilting the lift mast

To tilt the lift mast forwards:

- Move the "lift mast" 360° lever (1) in the direction of arrow (C).

To tilt the lift mast backwards:

- Move the "lift mast" 360° lever (1) in the direction of arrow (D).

i NOTE

The symbols on the 360° lever show the direction of movement of the lift mast and the fork carriage when the 360° lever is moved.

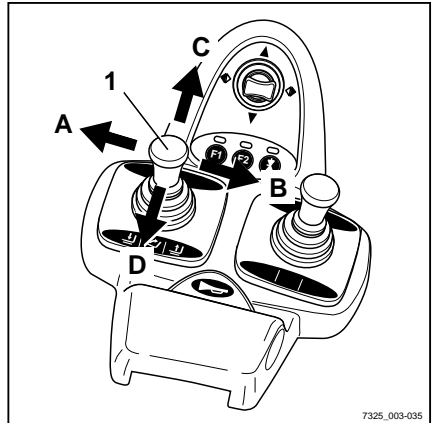

7325_003-035

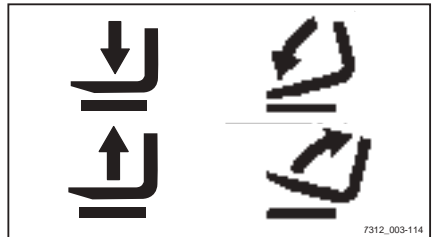

7312_003-114

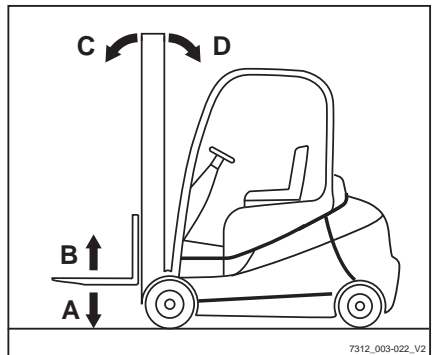

7312_003-022_V2

Lifting

Controlling the lifting system using a triple mini-lever ▷

⚠ DANGER

Reaching into or climbing between moving parts of the truck (e.g. lift mast, sideshifts, working equipment, load carrying devices etc.) can lead to serious injury or death and is therefore prohibited.

- Observe the safety regulations for handling loads.
- Operate the lifting system from the driver's seat only.

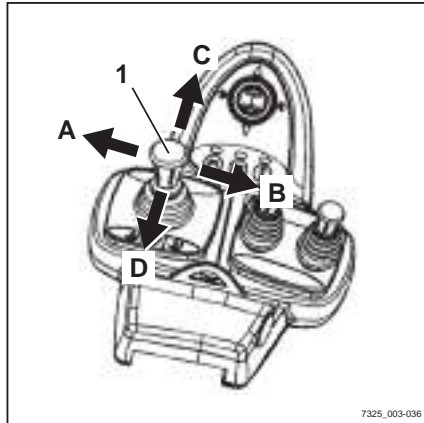

Lifting/lowering the fork carriage

To lift the fork carriage:

- Move the "lift mast" 360° lever (1) in the direction of arrow (B)

To lower the fork carriage:

- Move the "lift mast" 360° lever (1) in the direction of arrow (A)

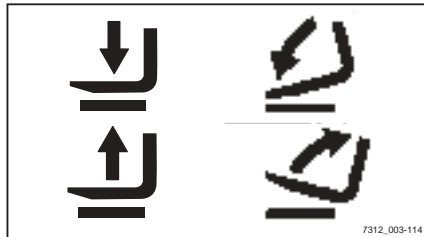

Tilting the lift mast

To tilt the lift mast forwards:

- Move the "lift mast" 360° lever (1) in the direction of arrow (C)

To tilt the lift mast backwards:

- Move the "lift mast" 360° lever (1) in the direction of arrow (D)

i NOTE

The symbols on the 360° lever show the direction of movement of the lift mast and the fork carriage when the 360° lever is moved.

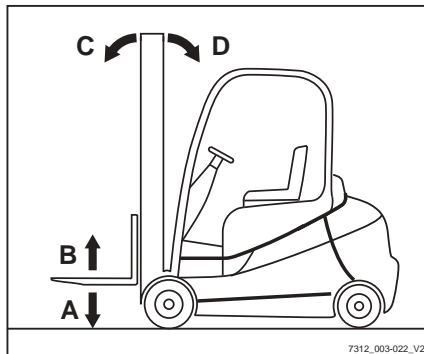

Controlling the lifting system using a quadruple mini-lever ▷

⚠ DANGER

Reaching into or climbing between moving parts of the truck (e.g. lift mast, sideshifts, working equipment, load carrying devices etc.) can lead to serious injury or death and is therefore prohibited.

- Observe the safety regulations for handling loads.
- Operate the lifting system from the driver's seat only.

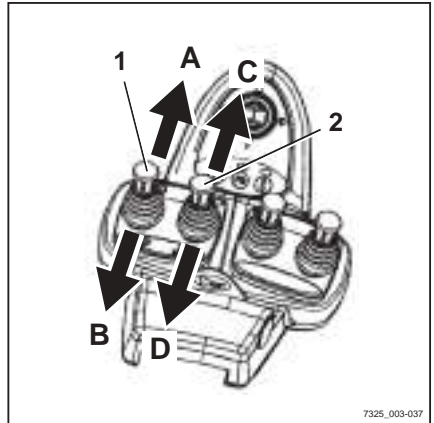

Tilting the lift mast

To tilt the lift mast forwards:

- Move the "lift mast" operating lever (1) in the direction of arrow (A).

To tilt the lift mast backwards:

- Move the "lift mast" operating lever (1) in the direction of arrow (B).

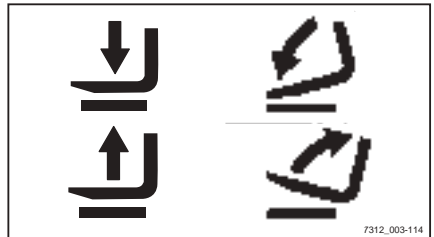

Lifting/lowering the fork carriage

To lift the fork carriage:

- Move the "lift-lower" operating lever (2) in the direction of arrow (D).

To lower the fork carriage:

- Move the "lift-lower" operating lever (2) in the direction of arrow (C).

i NOTE

The symbols on the operating levers show the direction of movement of the lift mast or fork carriage when the operating lever is moved.

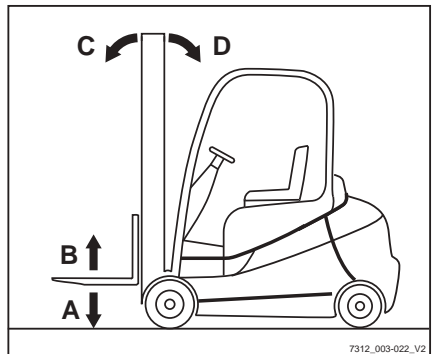

Lifting

Controlling the lifting system using the joystick 4Plus**⚠ DANGER**

Reaching into or climbing between moving parts of the truck (e.g. lift mast, sideshifts, working equipment, load carrying devices etc.) can lead to serious injury or death and is therefore prohibited.

- Observe the safety regulations for handling loads.
- Only operate the lifting system from the driver's seat.

Lifting/lowering the fork carriage

To lift the fork carriage:

- Pull the joystick 4Plus (1) backwards (B).

To lower the fork carriage:

- Push the joystick 4Plus (1) forwards (A).

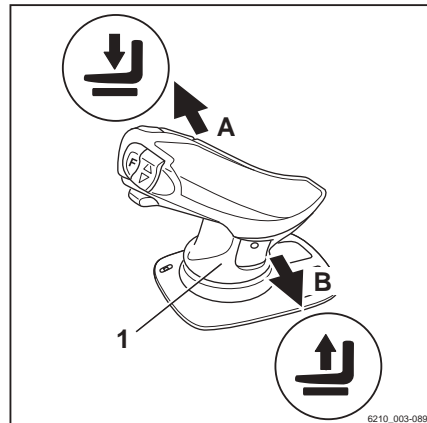

Tilting the lift mast

To tilt the lift mast forwards:

- Tilt the horizontal rocker button (2) to the left (C).

To tilt the lift mast backwards:

- Tilt the horizontal rocker button (2) to the right (D).

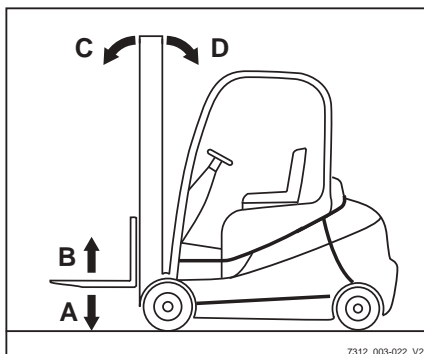
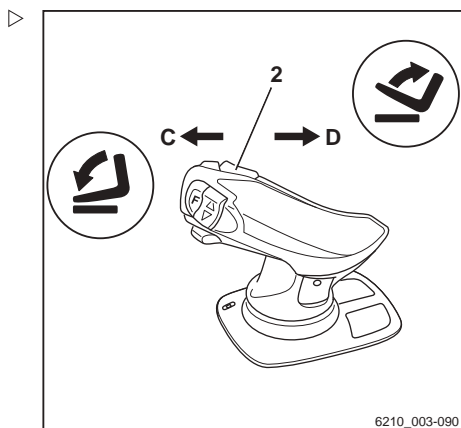

Fork-carriage sideshift

To move the fork carriage to the left.

- Push the joystick 4Plus (1) to the left (E).

To move the fork carriage to the right:

- Push the joystick 4Plus (1) to the right (F).

i NOTE

The symbols on the joystick 4Plus indicate the direction of movement of the lift mast or the fork carriage.

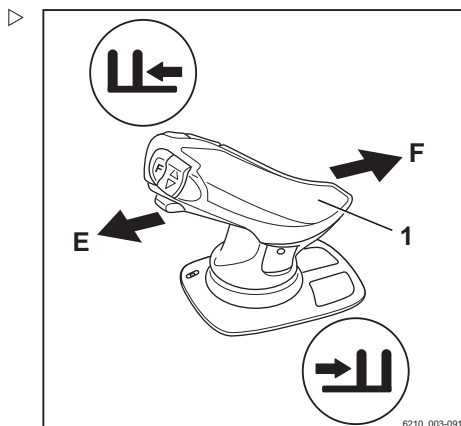

Lifting

Controlling the lifting system using the fingertip

⚠ DANGER

Reaching into or climbing between moving parts of the truck (e.g. lift mast, sideshifts, working equipment, load carrying devices etc.) can lead to serious injury or death and is therefore prohibited.

- Observe the safety regulations for handling loads.
- Operate the lifting system from the driver's seat only.

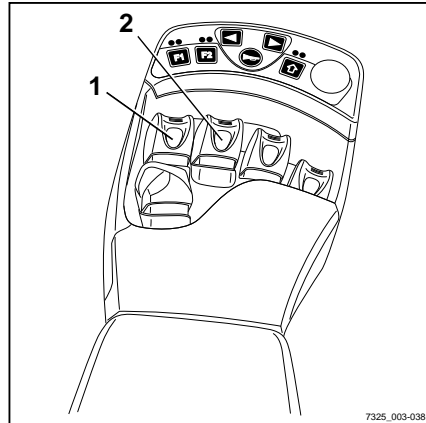

Lifting/lowering the fork carriage

To lift the fork carriage:

- Pull the "lift/lower" operating lever (1) backwards.

To lower the fork carriage:

- Push the "lift/lower" operating lever (1) forwards.

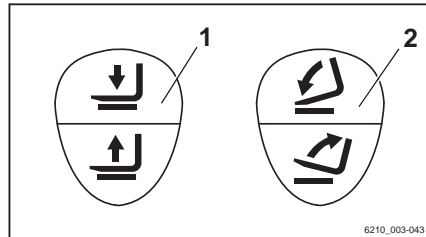

Tilting the lift mast

To tilt the lift mast forwards:

- Push the "tilt" operating lever (2) forwards.

To tilt the lift mast backwards:

- Pull the "tilt" operating lever (2) backwards.

i NOTE

The symbols on the operating levers show the direction of movement of the lift mast or fork carriage when the operating lever is moved.

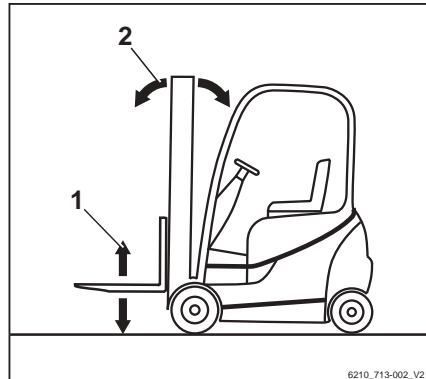

Changing the fork arms

DANGER

There is a risk of being run over if the truck rolls away, and therefore a danger to life.

- Do not park the truck on a gradient.
- Apply the parking brake.
- Change the fork arms in a separate, safe location on a level surface.

WARNING

There is a risk of injury when changing the fork arms; the fork arms' weight could cause them to fall on your legs, feet or knees. The space to the left and right of the fork is a danger area.

- Always wear protective gloves and safety footwear when changing the fork arms.
- Ensure that no one stands in the danger area!
- Do not pull on the fork arms.
- The fork arms must always be carried by two people; if necessary, use a hoist.

NOTE

- *For installation and removal, a transport pallet is recommended for supporting the fork arms. The pallet size depends on the fork arm size used and should be dimensioned such that the fork arms do not protrude after being placed on the pallet. This means the fork arms can be safely placed down and transported.*
- *Both fork arms can be pushed over onto one side.*

Lifting

Removal

- Select a pallet corresponding to the fork arm size.
- Position the pallet to the left or right of the fork carriage.
- Raise the fork carriage until the lower edges of the fork arms are approx. 3 cm higher than the height of the pallet.
- Actuate the parking brake and make sure it is applied securely.
- Turn the switch key to the left and remove it.
- Undo the locking screw (2) on the right or left.
- Pull the locking lever (1) upwards and push the fork arms outwards onto the pallet.

Installation

- Position the fork arms to the left or right of the fork carriage on a pallet.
- Push the fork arms onto the fork carriage from the outside towards the centre.
- Pull the locking lever (1) upwards and push the fork arms into the required position. Ensure that the locking lever snaps into place.
- Fit and tighten the locking screw (2).

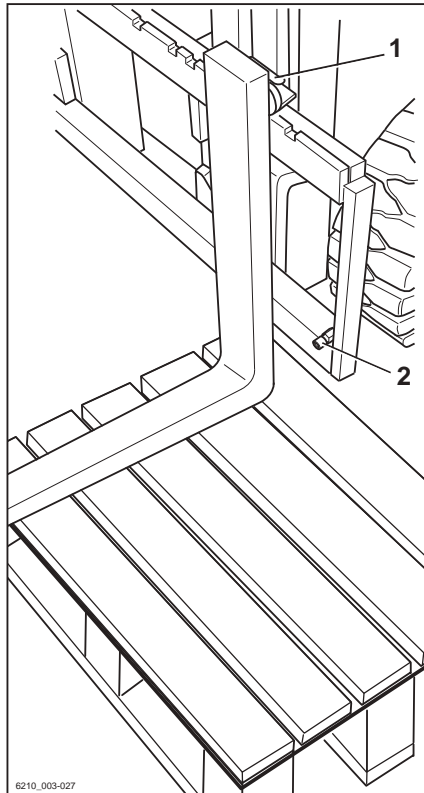

⚠ DANGER

There is a risk to life caused by a falling load or fork!

- Tighten the locking screw after every fork replacement.
- It is not permitted to drive or transport loads without the locking screw.



NOTE

If the truck is equipped with the "load measurement" comfort feature, then a "zero adjustment of the load measurement" is imperative after the fork arms have been changed; see ⇒ Chapter "Zero adjustment of the load measurement (variant)", P. 4-102. Otherwise correct measurement of the load cannot be guaranteed.

Fork extension (variant)

DANGER

There is a risk of being run over if the truck rolls away and therefore a danger to life.

- Do not park the truck on a slope.
- Apply the parking brake.
- Change the fork extension in a separate, safe location on a level surface.

WARNING

There is a risk of crushing!

The weight of the fork extension can cause crushing or cuts on sharp edges or burrs.

- Always wear protective gloves and safety footwear.

WARNING

There is a risk of tipping!

The weight and dimensions of the fork extension affect the stability of the truck. The permissible weights stated on the capacity rating plate must be reduced in proportion to the actual load distance.

The truck is equipped with a fork extension ex works, the capacity rating plate is already adjusted accordingly.

- Observe load capacity, see the "Before picking up a load" chapter.

NOTE

If the truck is equipped with the "load measurement" comfort feature, a "zero adjustment of the load measurement" must always be performed after the fork extensions have been changed. Otherwise, correct load measurement cannot be guaranteed.

Lifting

Attachment

⚠ DANGER**Risk to life from falling load!**

At least 60% of the length of the fork extension must lie on the fork arm. A maximum 40% overhang over the fork arm end is permissible. The fork extension must also be secured against slipping from the fork arm.

If the fork extension (1) is not secured with a securing bolt (2) and lynch pin (3), the load with the fork extension may fall.

- Push the fork extension completely to the back of the fork.
 - Make sure that 60% of the length of the fork extension is on the fork arm.
 - Always secure the fork extension with a securing bolt.
 - Always secure the securing bolt with a lynch pin.
-
- Remove the lynch pin (3) from the securing bolt (2).
 - Remove the securing bolt from the fork extension (1).
 - Push the fork extension onto the fork arms until it is flush with the fork back.
 - Insert the securing bolts located behind the fork back fully into the fork extension.
 - Insert the lynch pin into the securing bolt and secure.

Removal

- Remove the lynch pin (3) from the securing bolt (2).
- Remove the securing bolt from the fork extension (1).
- Pull the fork extension from the fork arms.
- Insert the securing bolt fully into the fork extension.
- Insert the lynch pin into the securing bolt and secure.

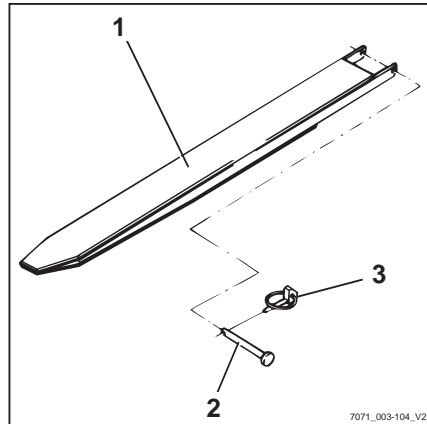

Operation with reversible fork arms (variant) ▷

⚠ DANGER

Risk to life from falling load!

Standard fork arms are not structurally designed for reverse operation. If this instruction is not observed, it can lead to material failure and the load falling.

- Only work in reverse operation using reversible fork arms (1)

⚠ WARNING

Risk of accident from slipping load!

Loads may slip on the reversible fork arms if there is no load support. A fork extension (variant) cannot be secured against slipping.

- Do not use a fork extension (variant)

⚠ WARNING

Risk of accident from the truck tipping over.

When driving, the centre of gravity of the load (2) must not be higher than 600 mm above the ground. The truck may tip forwards when driving or braking.

- Only drive with a load centre of gravity up to a max. of 600 mm above the ground

i NOTE

If the truck is equipped with the "load measurement" comfort feature, a "zero adjustment of the load measurement" must always be performed after the reversible fork arms have been changed. Otherwise, correct load measurement cannot be guaranteed.

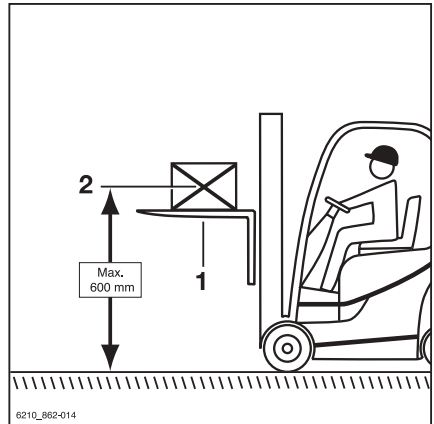

Lifting

Reversible fork arms (1) can be used to reach an additional lift height. The reversible fork arms are installed on the fork carriage in the same manner as standard fork arms. Loads may be lifted on and beneath the reversible fork arms. The mast is lifted and tilted in the same manner.

- Only work in reverse operation using reversible fork arms
- Do not use a fork extension (variant)
- If the "load measurement" comfort feature is available, perform a "zero adjustment of the load measurement"
- To drive, raise the load centre of gravity (2) to a max. of 600 mm above the ground
- Observe the information in the section entitled "Transporting suspended loads"

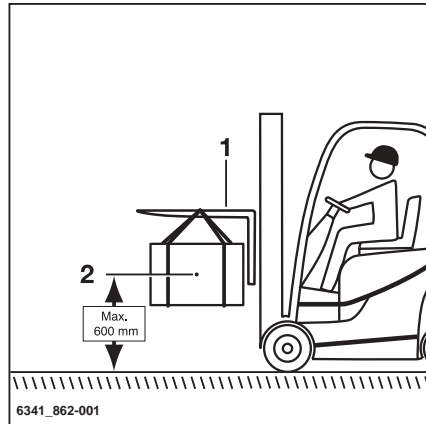

Working with loads

Safety regulations when handling loads

The safety regulations for handling loads are shown in the following sections.

⚠ DANGER

There is a risk to life caused by falling loads or if parts of the truck are being lowered.

- Never walk or stand underneath suspended loads or raised fork arms.
- Never exceed the maximum load indicated on the capacity rating plate. Otherwise stability cannot be guaranteed!

⚠ DANGER

Risk of accident from falling or crushing!

- Do not step onto the forks.
- Do not lift people.
- Never grab or climb on moving parts of the truck.

⚠ DANGER

Risk of accident from a falling load!

- When transporting small items, attach a load safety guard (variant) to prevent the load from falling on the driver.
- Use a closed roof covering (variant) in addition.



Working with loads

Before taking up load

Load capacity

The load capacity indicated for the truck on the capacity rating plate may not be exceeded. The load capacity is influenced by the load centre of gravity and the lift height as well as by the tyres, if applicable.

The position of the capacity rating plate can be found in the chapter entitled "Identification points".

⚠ WARNING

The figures show examples.

Only the capacity rating plates on the truck are valid!

The attachment of additional weights to increase load capacity is prohibited.

⚠ DANGER**Risk to life from the truck losing stability!**

Never exceed the maximum loads shown! These values apply to compact and homogenous loads. Otherwise, the stability as well as the rigidity of the fork arms and lift mast cannot be guaranteed.

Improper or incorrect operation or the placement of persons to increase load capacity is prohibited.

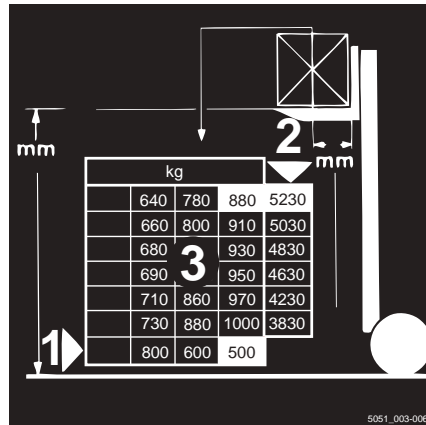

Example

Weight of load to be lifted: 880 kg (3)

Load distance from fork back: 500 mm (1)

Permitted lift height: 5230 mm (2)

⚠ WARNING

Risk of accident from the truck losing stability!

The permissible load of the attachments (variant) and the reduced lifting capacity of the combination of truck and attachment must not be exceeded.

- Observe the special capacity rating plate information shown on the truck and the attachment.

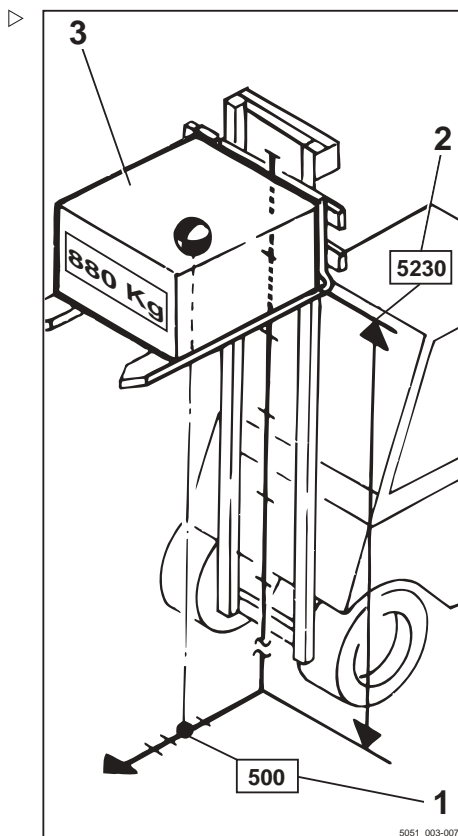
**Load measurement (variant)****Description**

Knowing the weight of the load to be transported gives the driver greater security. If the truck is equipped with the "load measurement" (variant) comfort feature, the weight of the lifted load can be measured and shown in the display and operating unit.

Load measurement is possible only when the truck is at a standstill. Before performing a load measurement, the load must be raised to a height of 300-800 mm above the ground.

Working with loads

The load measurement has an accuracy of +/-3% of the rated capacity of the truck.



NOTE

In order to ensure accuracy at all times, a zero adjustment of the load measurement must be carried out. Zero adjustment is required.

- *as part of daily commissioning*
- *after changing the fork arms*
- *after fitting or changing attachments.*

Performing the load measurement

DANGER

Risk of accident from a falling load!

The load may fall if the load centre of gravity has not been taken into account or the load has not been picked up securely.

- Pick up the load securely; see the chapter entitled "Picking up loads".

CAUTION

If the weight determined by a load measurement exceeds the permissible residual load capacity of the truck, the truck cannot be operated safely.

- Set down and reduce load immediately.
- If necessary, use another truck with sufficient load-bearing capacity.



NOTE

Accurate load measurement is only possible under the following conditions:

- *The hydraulic oil is at normal operating temperature*
- *The load is at rest at the beginning of the load measurement*
- *The load corresponds to at least 10% of the nominal load capacity in trucks with a load capacity of up to 2.5 t*
- *The load corresponds to at least 5% of the nominal load capacity in trucks with a load capacity of 3 t and over*
- *The lift mast is in the vertical position*
- *The fork is not raised to more than 800 mm above the ground*

i NOTE

The method of operating the lifting system depends on the operating devices included in the truck's equipment.

- Ensure that the truck has been in operation for a period of time before carrying out the load measurement.
- Set lift mast to vertical.
- Raise the fork to a height of 300–800 mm.
- Ensure that the load is at rest.
- Press button (1) for "load measurement"; the "load measurement" symbol (2) appears on the display highlighted in black.

i NOTE

If the truck is equipped with mini-levers or fingertip operation, the "F1" button can also be pressed as an alternative.

i NOTE

During the following process, the fork carriage must be lowered slightly and then stopped abruptly. While doing so, the fork must not touch the ground, otherwise the load measurement will not be accurate. To stop the lowering procedure quickly, release the operating device for lowering so that it jumps into the zero position.

- Lower the fork carriage slightly and release the operating device.

i NOTE

When stopping the lowering process the load must be cushioned in order to create a measurable impulse.

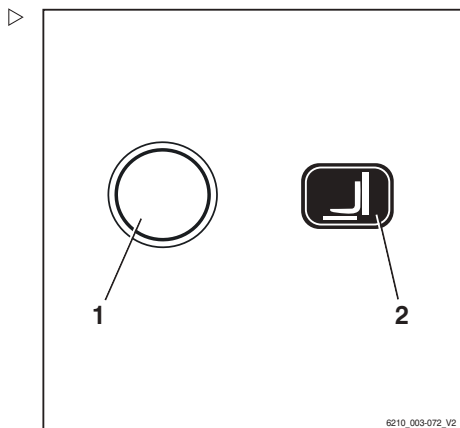

Working with loads

If load measurement has been carried out correctly, the determined load weight (3) is shown on the display of the display-operating unit.

NOTE

If the load measurement is invalid, the value "-9999 kg" is displayed in the operating unit.

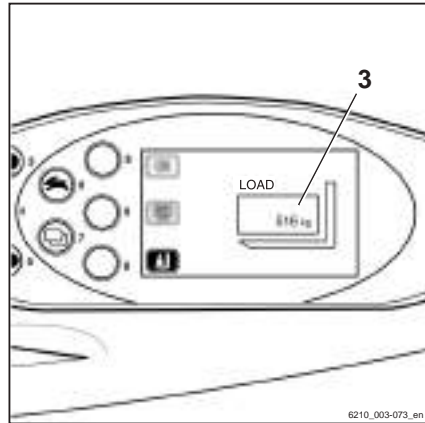

Picking up loads

To make sure that the load is securely supported, it must be ensured that the fork arms are sufficiently far apart and are positioned as far as possible under the load.

If possible, the load should rest on the back of the fork.

The load must not protrude too far over the fork tips, nor should the fork tips protrude too far out from the load.

Loads are to be picked up and transported as close to the middle as possible.

DANGER

Risk of accident from a falling load!

When transporting small items, attach a load safety guard (variant) to prevent the load from falling on the driver.

A closed roof covering (variant) should also be used.

Removable roof panels may not be removed.

Adjusting the fork

- Lift the locking lever (1) and move the fork arms to the desired position.
- Allow the locking lever to snap back into place.

The load centre of gravity must be midway between the fork arms.

- Only actuate the fork prong positioner (variant) when the fork is not carrying a load.

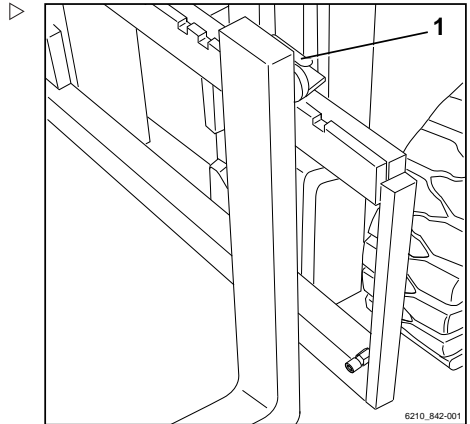

Danger area

The danger area is the area in which people are at risk due to the movements of the truck, its working equipment, its load-carrying equipment (e.g. attachments) or the load. Also included are the areas where loads could fall or working equipment could fall or be lowered.



⚠ DANGER

Risk of injury!

- Do not step on the fork.



⚠ DANGER

Risk of injury!

- Do not step under the raised forks.

⚠ DANGER

People may be injured in the danger area of the truck!

The danger area of the truck must be completely clear of all personnel, except the driver in his normal operating position. If persons fail to leave the danger area despite warnings:

- Cease work with the truck immediately.
- Secure the truck against use by unauthorised parties.

Working with loads



⚠ DANGER

Danger of death from falling loads!

- Never walk or stand underneath suspended loads.

Transporting pallets

As a rule, loads (e.g. pallets) must be transported individually. Transporting multiple loads at the same time is only permitted:

- when instructed by the supervisor and
- when the technical requirements have been met.

The driver must ensure proper condition of the load. Only safely and carefully positioned loads may be transported.

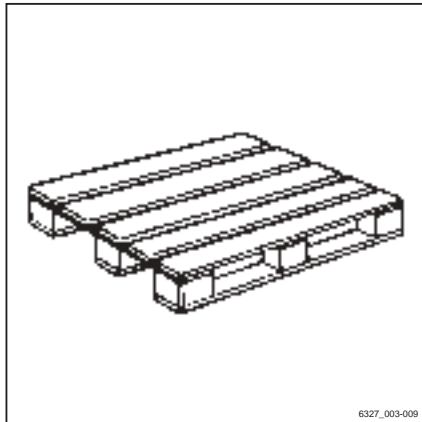

6327_003-009

Transporting suspended loads

Before transporting suspended loads, consult the national regulatory authorities (in Germany, the employer's liability insurance associations).

National regulations may place restrictions on these operations. Contact the relevant authorities.

⚠ DANGER

Suspended loads that begin to swing can result in the following risks:

- Impaired braking and steering action
- Tipping over the load wheels or drive wheels
- Tipping the truck at right angles to the direction of travel
- Risk of crushing of guide persons
- Reduced visibility.



6210_001-007

⚠ DANGER**Loss of stability.**

Slipping or swinging suspended loads can lead to a loss of stability and cause the truck to tip over.

- When transporting suspended loads, observe the following instructions

Instructions for transporting suspended loads:

- Swinging loads must be prevented by using the proper driving speed and driving style (careful steering, braking)
- Hanging loads must be hooked on to the truck in such a way that the harness cannot shift or release unintentionally and cannot be damaged
- When transporting suspended loads, suitable devices (e.g. guy wires or supporting poles) must be available so that accompanying persons can guide suspended loads and prevent the loads from swinging
- Take particular care to ensure that there is no one in the drive direction in the driving lane
- If, despite this, the load begins to swing, ensure that no person is placed at risk

⚠ DANGER**Risk of accidents!**

When transporting hanging loads, never perform or end driving and load movements abruptly.

Never drive on slopes with a suspended load.

Transporting containers holding fluids as hanging loads is not permitted.

Load pick up**⚠ DANGER**

There is a risk to life caused by a falling load or if parts of the truck are being lowered.

- Never walk or stand underneath suspended loads or raised fork arms.
 - Never exceed the maximum load values specified on the capacity rating plate. Otherwise, stability cannot be guaranteed.
-
- Only store pallets which do not exceed the specified maximum size. Damaged loading

Working with loads

equipment and incorrectly formed loads must not be stored.

- Attach or secure the load to the load-carrying equipment so that the load cannot move or fall.
- Store the load so that the specified aisle width is not reduced by protruding parts.
- Approach the racking carefully, brake gently and stop just in front of the racking. ▷

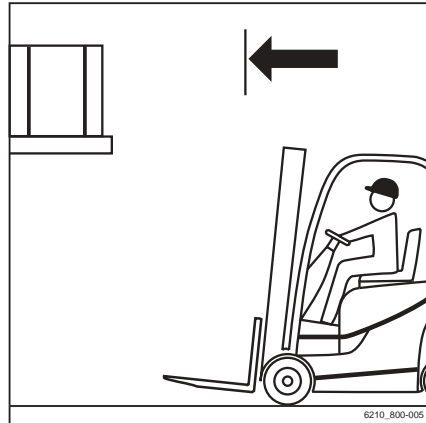

- Position the forks.
- Set lift mast to vertical.
- Lift the fork carriage to the stacking height. ▷

⚠ CAUTION

Component damage possible!

When inserting the fork into the racking, ensure that the racking and load are not damaged.

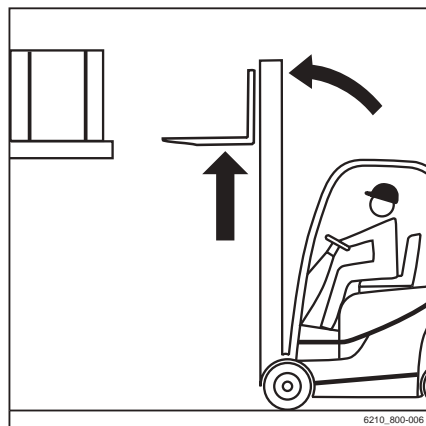

- Insert the fork as far under the load as possible. Stop the truck as soon as the fork back is resting on the load. The centre of gravity of the load must be positioned between the fork arms in the middle.



- Lift the fork carriage until the load is resting entirely on the forks.

⚠ DANGER

Risk of accidents!

- Beware of any people in the danger area.

⚠ CAUTION

Component damage possible!

- Ensure that the roadway behind you is clear.
- Move backwards carefully and slowly until the load is clear of the racking. Brake gently.

⚠ DANGER

Never tilt the lift mast with a raised load due to the risk of tipping!

- Lower the load before tilting the lift mast.

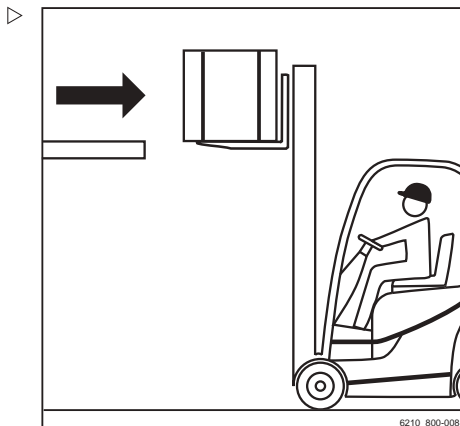

Working with loads

- Lower the load while maintaining ground clearance. ▷

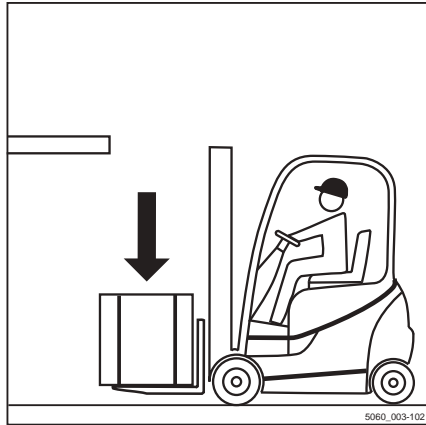

- Tilt the lift mast backwards.
The load can be transported. ▷

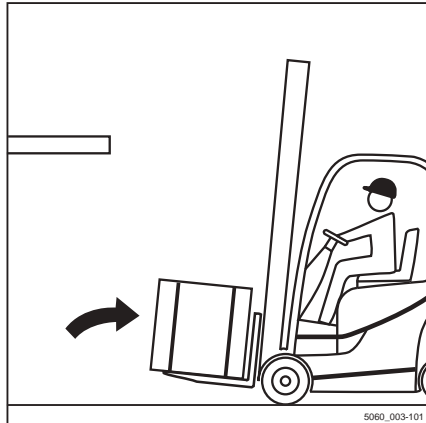

Transporting loads

NOTE

Observe the information in the chapter entitled "Safety regulations when driving".

DANGER

The higher a load is lifted, the less stable it becomes. The truck can tip over or the load can fall, increasing the risk of accident!

Driving with a raised load and the lift mast tilted forward is not permitted.

- Only drive with the load lowered.
- Lower the load until ground clearance is reached (not over 300 mm).
- Only drive with the lift mast tilted backwards.

- Drive slowly and carefully round corners!

NOTE

Observe the information in the chapter entitled "Steering".

- Always accelerate and brake gently!

NOTE

Observe the information in the chapter entitled "Operating the service brake".



Working with loads

- Never drive with a load protruding to the side (e.g. with the sideshift)!



Setting down loads

⚠ DANGER

Risk of accident due to changed moment of tilt!

The load centre of gravity and the moment of tilt move due to tilting the lift mast forwards with a raised load or due to the load slipping. The truck may tip forwards.

- Only tilt the lift mast forwards with a raised lifting accessory when it is directly above the stack.
- When the lift mast is tilted forwards, take particular care to ensure that the truck does not tip forwards and that the load does not slip.

⚠ WARNING

Risk of accident from a falling load!

If the fork or the load remains suspended during lowering, the load may fall.

- When removing from stock, move the truck far enough back so that the load and the fork can be lowered freely.

- Drive up to the stack with the load lowered in accordance with regulations. ▷
- Set lift mast to vertical.
- Lift the load to the stacking height.
- Drive the truck towards the rack carefully.



- Lower the load until it rests securely on the rack. ▷

⚠ DANGER

Risk of accident!

- Beware of any people in the danger area.
 - Ensure that the roadway behind you is clear.
-
- Move the truck back until the fork arms can be lowered without touching the stack.
 - Lower the fork while maintaining ground clearance.
 - Tilt the lift mast backwards and drive away.



Working with loads

Driving on lifts

The driver may only use this truck on lifts with a sufficient rated capacity and for which the operating company has been granted authorisation.

⚠ DANGER

There is a risk to life if you are crushed or run over by the truck.

- There must be no personnel already in the lift when the truck is driven into the lift.
- Personnel are only permitted to enter the lift once the truck is secure, and must exit the lift before the truck is driven out.

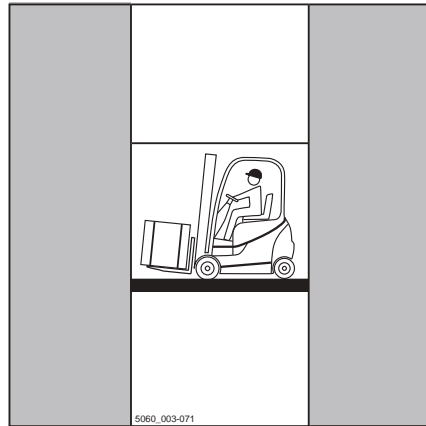

Determining the actual total weight

- Park the truck securely.
- Determine the unit weights by reading the truck nameplate and, if necessary, the attachment (variant) nameplate and, if necessary, by weighing the load to be lifted.
- Add the determined unit weights to obtain the actual total weight of the truck:

Tare weight (1)

- + Ballast weight (variant) (2)
- + Attachment net weight (variant)
- + Weight of the load to be lifted
- + 100 kg allowance for driver
- = Actual total weight

- Drive the truck with the forks forwards into the lift without touching the shaft walls.
- Park the truck securely in the lift to prevent uncontrolled movements of the load or the truck.

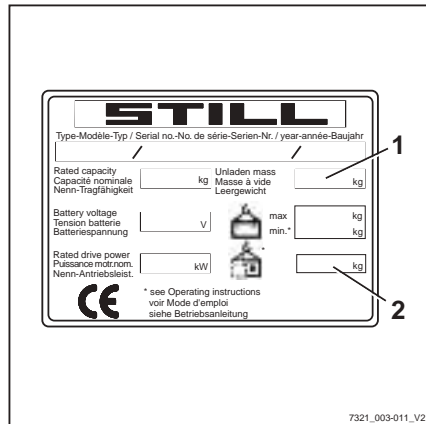

Driving on loading bridges

⚠ DANGER

Risk of accident if the truck crashes!

Steering movements can cause the tail end to veer off the loading bridge towards the edge. This may cause the truck to crash.

The lorry driver and the truck driver must agree on the lorry's departure time.

- Before driving across a loading bridge, ensure that it is properly attached and secured and has a sufficient load capacity (lorry, bridge etc.).
- Drive slowly and with care on the loading bridge.
- Ensure that the vehicle onto which you will be driving is secured to prevent it from shifting and that it can support the load of the truck.

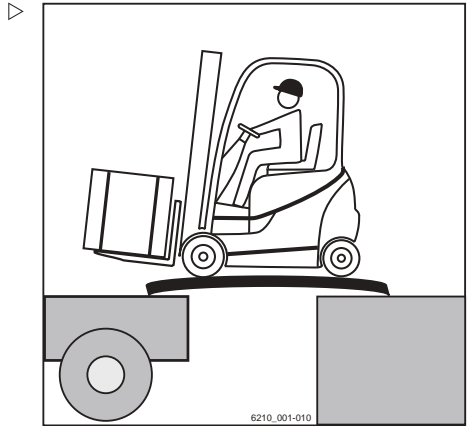

Determining the actual total weight

- Park the truck securely.
- Determine the unit weights by reading the truck nameplate and, if necessary, the attachment (variant) nameplate and, if necessary, by weighing the load to be lifted.
- Add the determined unit weights to obtain the actual total weight of the truck:

- Tare weight (1)
- + Ballast weight (variant) (2)
- + Attachment net weight (variant)
- + Weight of the load to be lifted
- + 100 kg allowance for driver
- = Actual total weight

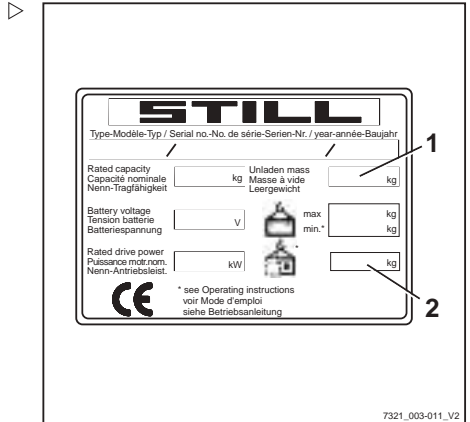

Attachments

Attachments

Fitting attachments

If the truck is equipped with an integrated attachment (variant) at the factory, the specifications in the STILL operating instructions for integrated attachments must be observed.

If attachments are fitted at the place of use, the specifications in the operating instructions of the attachment manufacturer must be observed.

If an attachment is not delivered together with the forklift truck, the specifications and operating instructions of the attachment manufacturer must be observed.

Before initial commissioning, the function of the attachment and the visibility from the driver's position with and without a load must be checked by a competent person. If the visibility is deemed insufficient, visual aids such as mirrors, a camera/monitor system etc. must be used.

In addition, it is essential that the warnings below are observed.

CAUTION

Attachments must be CE-certified. If the truck is not fitted with an attachment-specific residual load capacity rating plate and the operating devices are not marked with corresponding pictograms, the truck must not be used.

- Order the residual load capacity rating plate and pictograms from your authorised service centre in good time.
- The authorised service centre must adapt the hydraulic system to the requirements of the attachment (e.g. by adjusting the pump motor speed).

⚠ DANGER**There is risk to life caused by a falling load!**

Attachments that hold the load by exerting pressure on it (e.g. clamps) must be controlled additionally by a second operating function (lock) that is actuated to prevent an unintentional release of the load.

If such an attachment is retrofitted, a second operating function for actuation must also be retrofitted.

- Make sure that the additional clamp locking mechanism function is available.

⚠ DANGER**There is risk to life caused by a falling load!**

During installation of a clamp with integral sideshift, ensure that the clamp does not open when the sideshift is actuated.

- Notify your authorised service centre before installation.
- Never grab or climb on moving parts of the truck.

Hydraulic connection

- Before installing the attachment, release the pressure from the hydraulic system.

⚠ CAUTION

Risk of damage to components!

Open connections of plug connectors can become dirty. The plug connectors can become stiff and dirt can enter the hydraulic system.

- Once the attachment has been disassembled, attach the protective caps to the plug connectors.

Mounting attachments

Mounting an attachment and connecting the energy supply for an attachment must only be performed by competent persons in accordance with the information provided by the manufacturer and supplier of the attachment. After each installation, the attachment must be checked for correct function prior to initial commissioning.

i NOTE

Please observe the definition of the following responsible person: "competent person".

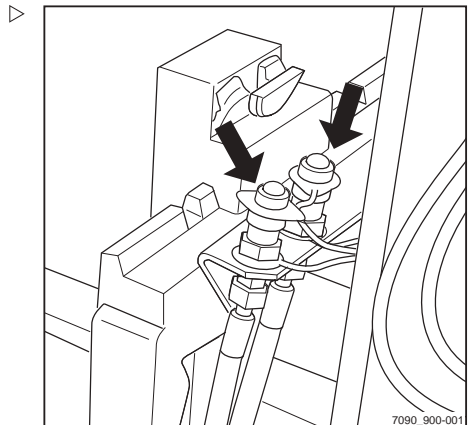

Attachments

Load capacity with attachment

The permissible load capacity of the attachment and the allowable load (load capacity and load moment) of the truck must not be exceeded by the combination of attachment and payload. The specifications of the manufacturer and supplier of the attachment must be complied with.

- Observe the residual load capacity rating plate, see the chapter entitled "Taking up a load using attachments".

Releasing the pressure from the hydraulic system

Prior to assembling attachments, the plug connectors must be depressurised.

Attachments must only be installed by authorised personnel in accordance with the information provided by the manufacturer and supplier of the attachments. After each installation, the attachment must be checked for correct function prior to initial commissioning.

NOTE

The pressure release procedure is dependent on the operating devices for controlling the hydraulic functions; see the section entitled "Lifting system operating devices".

NOTE

Before carrying out pressure release, lower the fork carriage and tilt the lift mast back to the stop. The key switch must be switched on to release the pressure from the system, but do not start the engine.

NOTE

In trucks with the "FleetManager" or "access authorisation with PIN code" equipment variants, access authorisation must be enabled.

- Switch on the key switch.
- Wait two to three seconds.

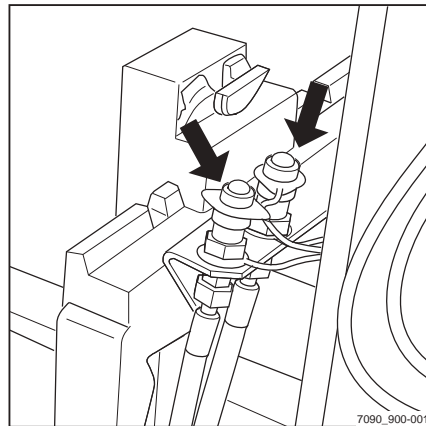

7090_900-001

- Actuate the operating lever (1) for controlling the hydraulic functions repeatedly in the direction of the arrow, as far as the end position.

The valves open and the hydraulic system is depressurised.

- Switch off the key switch.

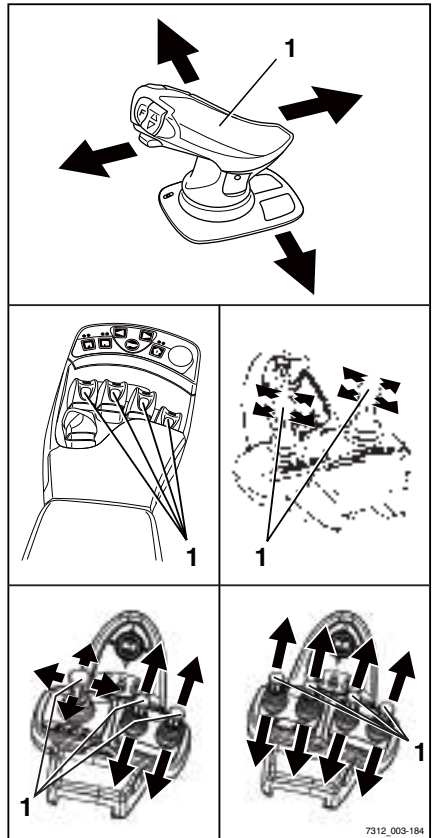

7312_003-184

Attachments

General instructions for controlling attachments

The way in which attachments (variant) are controlled depends on the operating devices included in the truck's equipment.

Essentially, a distinction is drawn between:

- **Double mini-lever**
 - **Double mini-lever with a 5th function**
(variant)
 - **Triple mini-lever**
 - **Triple mini-lever with a 5th function** (variant)
 - **Quadruple mini-lever**
 - **Quadruple mini-lever with a 5th function**
(variant)
 - **Joystick 4Plus**
 - **Joystick 4Plus with a 5th function** (variant)
 - **Fingertip switch**
 - **Fingertip with a 5th function** (variant)
- For information on controlling attachments with the respective operating devices, see the relevant sections in this chapter.

WARNING

Use of attachments can give rise to additional hazards such as a change in the centre of gravity, additional danger areas etc.

Attachments must only be used for their intended purpose as described in the relevant operating instructions. Drivers must be taught how to operate the attachments.

Loads may only be picked up and transported with attachments if the loads are securely grasped and attached. Where necessary, loads must also be secured against slipping, rolling away, falling over, swinging or tipping over. Note that any change to the position of the load centre of gravity will affect the stability of the truck.

- Refer to the capacity rating plate for the attachments being used.

NOTE

Further variants and functions are available in addition to the functions described below. The directions of movement can be seen on the pictograms on the operating devices.

 **NOTE**

All the attachments described fall into the category of equipment variants. Please see the respective operating instructions for an exact description of the respective movements/actions of the attachment fitted.

Attachments

Controlling attachments using a double mini-lever

The attachments (variants) are controlled in this version using the "attachments" cross lever (1).

The pictograms on the "attachments" cross lever show the respective functions that are activated by this lever.

This essentially involves the following:

- Move the "attachments"(1) cross lever in the direction of the arrow (A) .

The attachment moves in accordance with the pictogram in position (A).

- Move the "attachments"(1) cross lever in the direction of the arrow (B) .

The attachment moves in accordance with the pictogram in position (B).

- Move the "attachments"(1) cross lever in the direction of the arrow (C) .

The attachment moves in accordance with the pictogram in position (C).

- Move the "attachments"(1) cross lever in the direction of the arrow (D) .

The attachment moves in accordance with the pictogram in position (D).

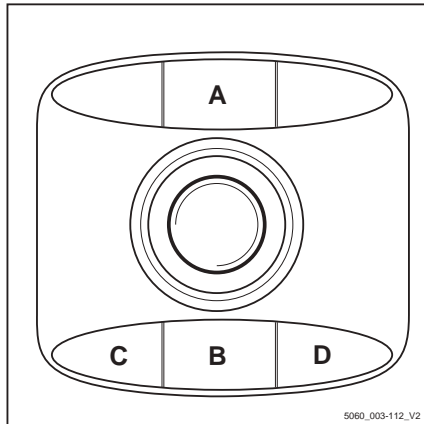
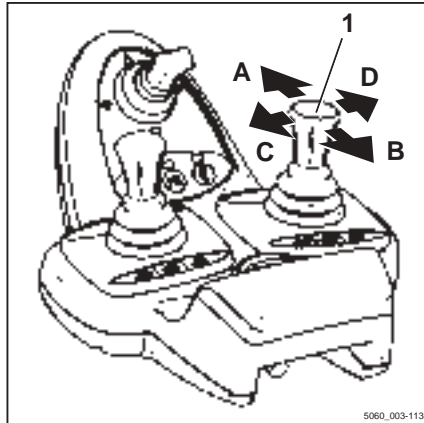

- Note the following attachment functions and pictograms. ▷

3	Move sideshift frame or fork forwards
4	Move sideshift frame or fork backwards
5	Move sideshift to the left
6	Move sideshift to the right
7	Adjust fork arms: open
8	Adjust fork arms: close
9	Swivel lift mast or fork to the left
10	Swivel lift mast or fork to the right
11	Release load retainer
12	Clamp load retainer
13	Push off the load
14	Pull in the load
15	Open clamps
16	Close clamps
17	Rotate to the left
18	Rotate to the right
19	Tip shovel over
20	Tip shovel back

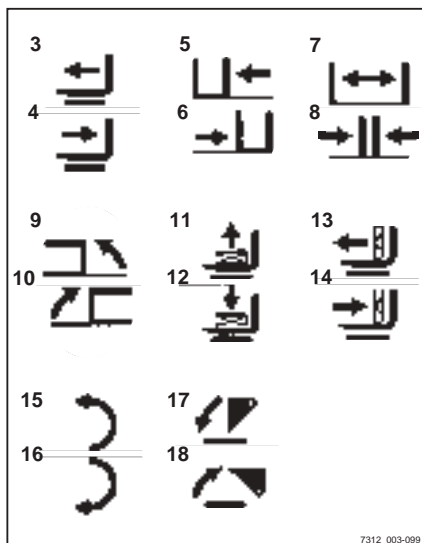

i NOTE

The pictograms shown correspond to the attachments fitted to this truck at the factory. If an attachment with other functions is fitted, the pictograms must be checked for the correct representation and changed if necessary.

- Contact the authorised service centre if required.

Attachments

Controlling attachments using the double mini-lever and the 5th function

NOTE

For technical reasons, clamping attachments **cannot** be controlled via the 5th function.

NOTE

The "lift mast" 360° lever and the "attachments" cross lever (2) control four hydraulic functions. The designation "5th function" refers to the fact that the 5th hydraulic function can be controlled with the cross lever by switching the functions using the "5th function" function key (1).

The pictograms on the "attachments" cross lever (2) show the respective functions that are activated by this lever.

This essentially involves the following:

- Actuate the "5th function" function key (1) and move the "attachments" cross lever (2) in the direction of arrow (E).

The attachment moves in accordance with the pictogram in position (E).

- Actuate the "5th function" function key (1) and move the "attachments" cross lever (2) in the direction of arrow (F).

The attachment moves in accordance with the pictogram in position (F).

NOTE

The pictograms are attached depending on the pre-assembled attachment. If an attachment with other functions is fitted, the pictograms must be checked for the correct representation and changed if necessary.

- Contact the authorised service centre if required.

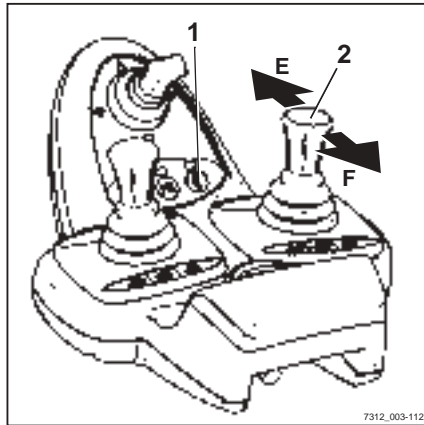

7312_003-112

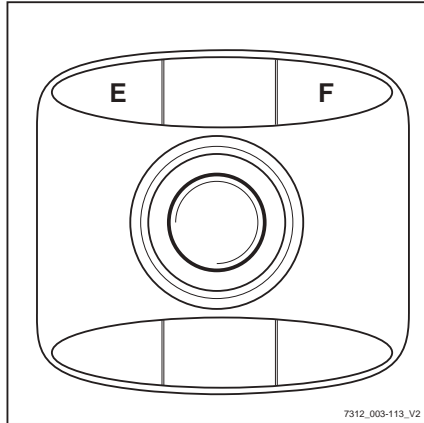

7312_003-113_V2

– Note the following attachment functions and pictograms.

3	Move sideshift frame or fork forwards
4	Move sideshift frame or fork backwards
5	Move sideshift to the left
6	Move sideshift to the right
7	Adjust fork arms: open
8	Adjust fork arms: close
9	Swivel lift mast or fork to the left
10	Swivel lift mast or fork to the right
11	Release load retainer
12	Clamp load retainer
13	Push off the load
14	Pull in the load
15	Rotate to the left
16	Rotate to the right
17	Tip shovel over
18	Tip shovel back

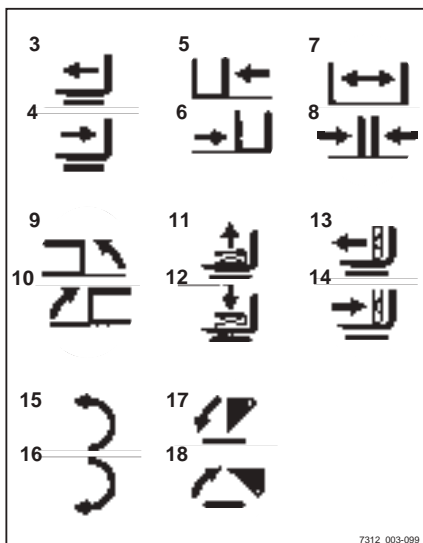

Attachments

Controlling attachments using a triple mini-lever

The attachments (variant) are controlled in this version using operating levers (1) and (2).

The pictograms on the operating levers show the respective functions that are activated by these levers.

This essentially involves the following:

- Move the operating lever (1) towards (A)

The attachment moves in accordance with the pictogram in position (A).

- Move the operating lever (1) towards (B)

The attachment moves in accordance with the pictogram in position (B).

- Move the operating lever (2) towards (C)

The attachment moves in accordance with the pictogram in position (C).

- Move the operating lever (2) towards (D)

The attachment moves in accordance with the pictogram in position (D).

NOTE

The pictograms are attached depending on the pre-assembled attachment. If an attachment with other functions is fitted, the pictograms must be checked for the correct representation and changed if necessary.

- Contact the authorised service centre if required.

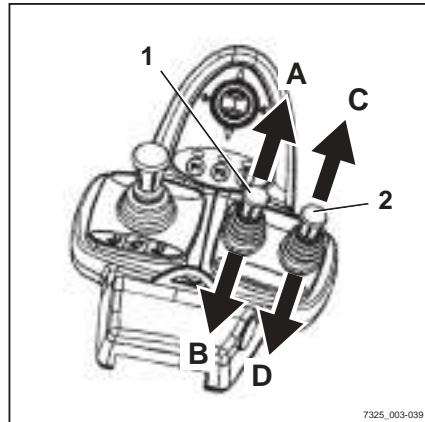

7325_003-039

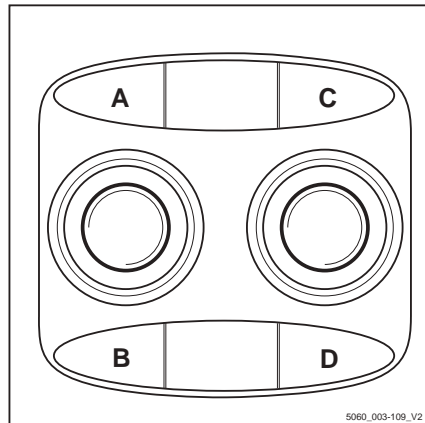

5060_003-109_V2

– Note the following attachment functions and pictograms! ▷

3	Move sideshift frame or fork forwards
4	Move sideshift frame or fork backwards
5	Move sideshift to the left
6	Move sideshift to the right
7	Adjust fork arms: open
8	Adjust fork arms: close
9	Swivel lift mast or fork to the left
10	Swivel lift mast or fork to the right
11	Release load retainer
12	Clamp load retainer
13	Push off the load
14	Pull in the load
15	Open clamps
16	Close clamps
17	Rotate to the left
18	Rotate to the right
19	Tip shovel over
20	Tip shovel back

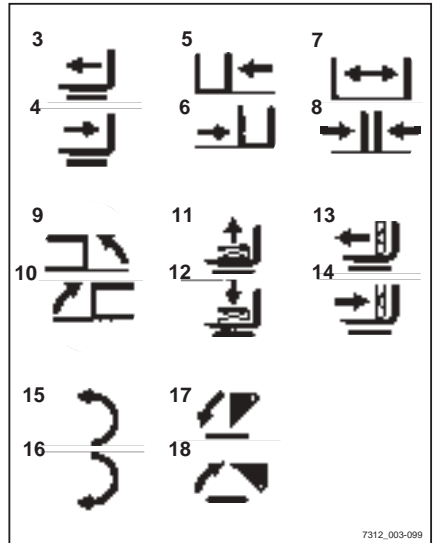

7312_003-099

Attachments

Controlling attachments using the triple mini-lever and the 5th function

NOTE

For technical reasons, clamping attachments **cannot** be controlled via the 5th function.

NOTE

The "lift mast" 360° lever and operating levers (1) and (2) control four hydraulic functions. The designation "5th function" refers to the fact that the 5th hydraulic function can be controlled with the operating lever (1) by switching the functions using the function key (3).

The pictograms on the operating levers show the respective functions that are activated by these levers.

This essentially involves the following:

- Actuate the "5th function" function key (3) and move operating lever (1) towards (E).

The attachment moves in accordance with the pictogram in position (E).

- Actuate the "5th function" function key (3) and move operating lever (1) towards (F).

The attachment moves in accordance with the pictogram in position (F).

NOTE

The pictograms are attached depending on the pre-assembled attachment. If an attachment with other functions is fitted, the pictograms must be checked for the correct representation and changed if necessary.

- Contact the authorised service centre if required.

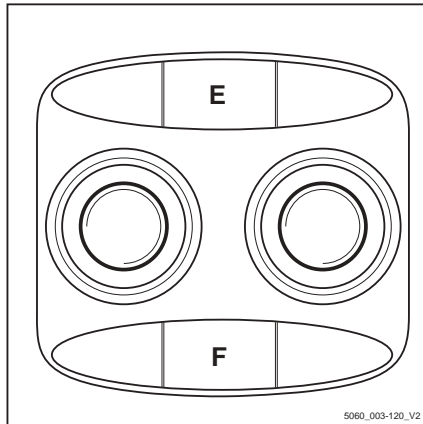
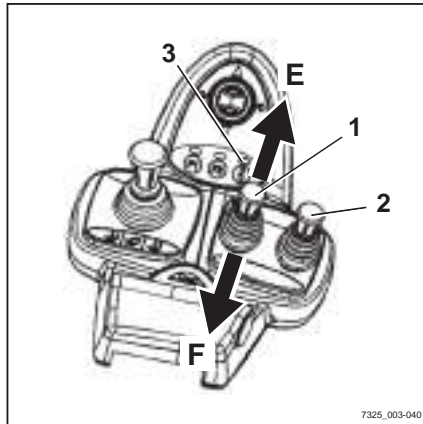

- Note the following attachment functions and pictograms. ▷

1	Adjust fork arms: open
2	Adjust fork arms: close
3	Rotate to the left
4	Rotate to the right

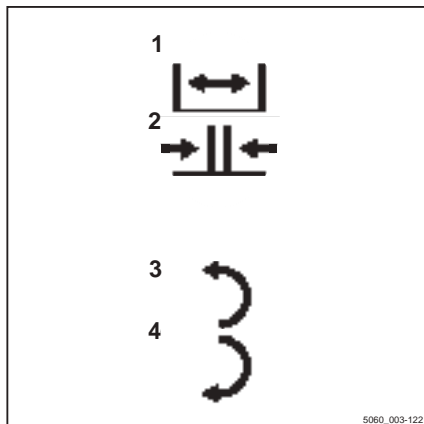

Attachments

Controlling attachments using a quadruple mini-lever

The attachments (variant) are controlled in this version using operating levers (1) and (2).

The pictograms on the operating levers show the respective function that is activated by these levers.

This essentially involves the following:

- Move the operating lever (1) towards (A)

The attachment moves in the direction shown in pictogram (A).

- Move the operating lever (1) towards (B)

The attachment moves in the direction shown in pictogram (B).

- Move the operating lever (2) towards (C)

The attachment moves in the direction shown in pictogram (C).

- Move the operating lever (2) towards (D)

The attachment moves in the direction shown in pictogram (D).

NOTE

The pictograms are attached depending on the pre-assembled attachment. If an attachment with other functions is fitted, the pictograms must be checked for the correct representation and changed if necessary.

- Contact the authorised service centre if required.

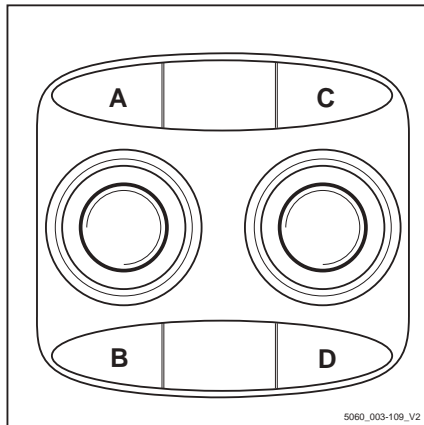
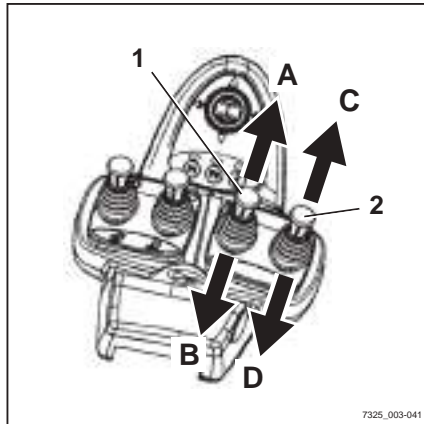

– Note the following attachment functions and pictograms! ▷

3	Move sideshift frame or fork forwards
4	Move sideshift frame or fork backwards
5	Move sideshift to the left
6	Move sideshift to the right
7	Adjust fork arms: open
8	Adjust fork arms: close
9	Swivel lift mast or fork to the left
10	Swivel lift mast or fork to the right
11	Release load retainer
12	Clamp load retainer
13	Push off the load
14	Pull in the load
15	Open clamps
16	Close clamps
17	Rotate to the left
18	Rotate to the right
19	Tip shovel over
20	Tip shovel back

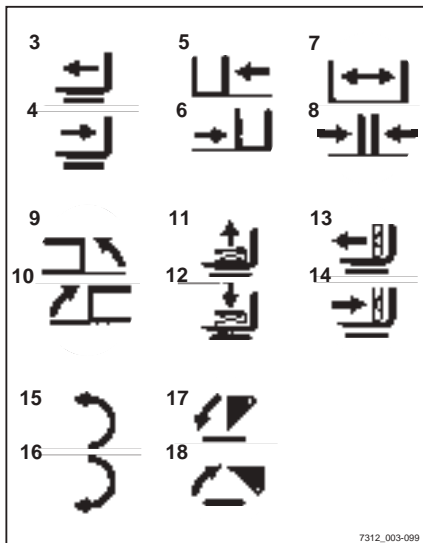

Attachments

Controlling attachments using the quadruple mini-lever and the 5th function

NOTE

For technical reasons, clamping attachments **cannot** be controlled via the 5th function.

NOTE

Operating levers (1) to (4) are used to control four hydraulic functions. The designation "5th function" refers to the fact that the 5th hydraulic function can be controlled with the operating lever (3) by switching the functions using the "5th function" function key (5).

The pictograms on the operating levers show the respective functions that are activated by these levers.

This essentially involves the following:

- Actuate the "5th function" function key (5) and move operating lever (3) towards (E).

The attachment moves in accordance with the pictogram in position (E).

- Actuate the "5th function" function key (5) and move operating lever (3) towards (F).

The attachment moves in accordance with the pictogram in position (F).

NOTE

The pictograms are attached depending on the pre-assembled attachment. If an attachment with other functions is fitted, the pictograms must be checked for the correct representation and changed if necessary.

- Contact the authorised service centre if required.

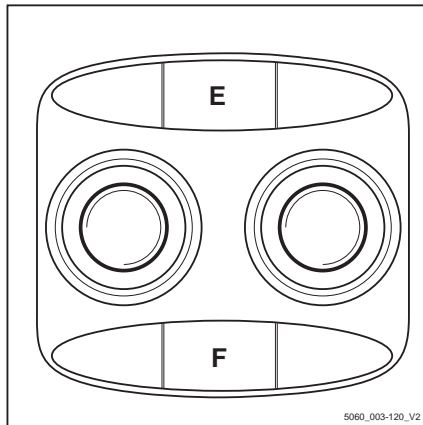
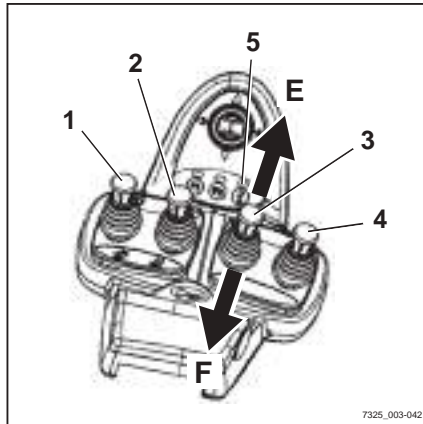

- Note the following attachment functions and pictograms. ▷

1	Adjust fork arms: open
2	Adjust fork arms: close
3	Rotate to the left
4	Rotate to the right

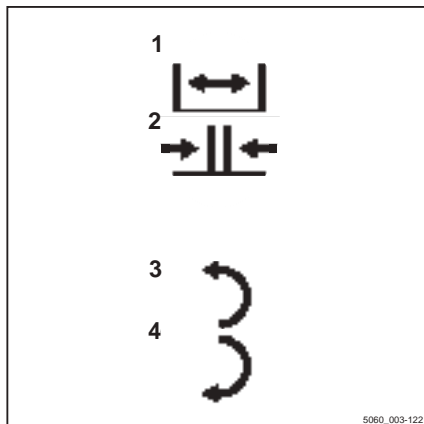

Attachments

Controlling attachments via the joystick 4Plus

In this equipment, the attachments (variant) are controlled via the joystick 4Plus (1).

The pictograms on the decal information about operation of the joystick 4Plus show the respective functions that are activated by the individual operating devices of the joystick 4Plus.

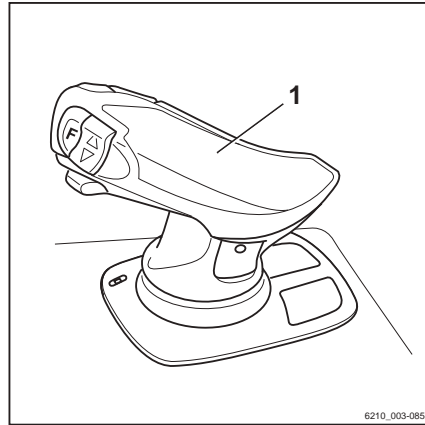

6210_003-085

– Note the following attachment functions and pictograms. 

	Operating device	Function of the attachment
1	Joystick 4Plus	Move sideshift to the left/right
2	Joystick 4Plus or slider	Adjust fork arms: open/close
3	Slider	Move reach frame or fork carriage forwards/backwards
4	Joystick 4Plus or slider	Rotate attachment left/right
5	Slider	Tip shovel over/tip shovel back

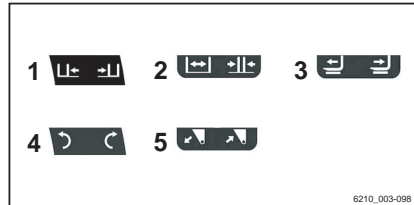

6210_003-098



NOTE

The pictograms on the joystick 4Plus are attached according to the attachments fitted to this truck at the factory. If an attachment with other functions is fitted, the pictograms must be checked for the correct representation and changed if necessary.

– Contact the authorised service centre if required.

Controlling attachments using the joystick 4Plus and the 5th function

NOTE

For technical reasons, clamping attachments **cannot** be controlled via the 5th function.

NOTE

The 5th hydraulic function can be used to control an attachment. The pictograms on the joystick 4Plus show which attachment functions can be controlled using the 5th function.

For attachments that are controlled using the 5th hydraulic function, the procedures for operation are as follows:

- Press and hold shift key "F"(1) on the joystick 4Plus.
- Simultaneously actuate the horizontal rocker button (2) in the direction shown in the pictogram.

The attachment moves in the selected direction.

NOTE

The pictograms are attached depending on the pre-assembled attachment. If an attachment with other functions is fitted, the pictograms must be checked for the correct representation and changed if necessary.

- Contact the authorised service centre if required.

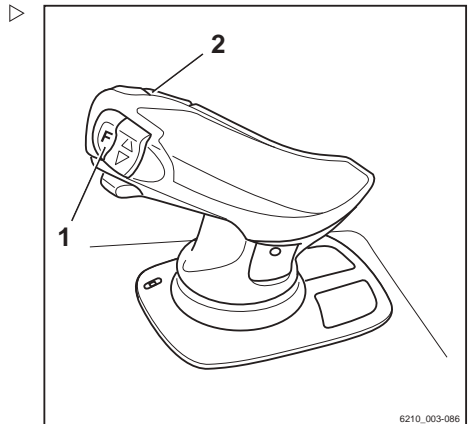

6210_003-086

Attachments

Controlling the attachments with the fingertip

The attachments (variant) are controlled in this version using the operating levers (1).

The pictograms on the operating levers show the functions that are activated by that lever.

- Move the operating lever (1) forwards

The attachment moves in the direction of movement shown in the upper part of the pictogram.

- Move the operating lever (1) backwards

The attachment moves in the direction of movement shown in the lower part of the pictogram.

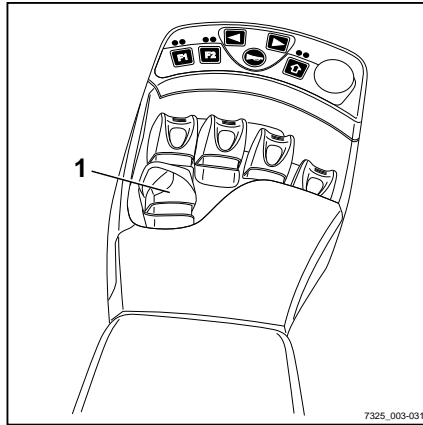

NOTE

The pictograms are attached depending on the pre-assembled attachment. If an attachment with other functions is fitted, the pictograms must be checked for the correct representation and changed if necessary.

- Contact the authorised service centre if required.
- Note the following attachment functions and pictograms!

2	Move side shift frame or fork forwards/backwards
3	Move sideshift to the left/right
4	Adjust fork arms: open/close
5	Swivel lift mast or fork to the left/right
6	Release/clamp load retainer
7	Push off/pull in load
8	Open/close clamps
9	Turn to the left/right
10	Tip shovel over/tip shovel back

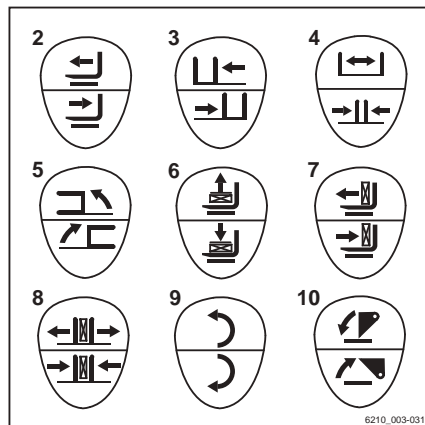

Controlling attachments with the fingertip and 5th function

NOTE

For technical reasons, clamping attachments **cannot** be controlled via the 5th function.

NOTE

The designation "5th function" refers to the fact that the four operating levers control four functions, while the "5th function" can be controlled by switching functions.

The attachments (variant) are controlled using the operating levers (1).

You can also use the switch (2) to switch functions, in which case the corresponding operating lever controls the "5th function".

The upper and lower parts of the pictogram (3) behind the operating lever show the function that is activated with this lever.

This essentially involves the following:

- Move the operating lever forwards

The attachment moves in the direction of movement shown in the upper part of the pictogram.

- Move the operating lever backwards

The attachment moves in the direction of movement shown in the lower part of the pictogram.

- Actuate the switch (2)

The additional function of the attachment is activated/deactivated and can be controlled as the "5th function" using the operating lever.

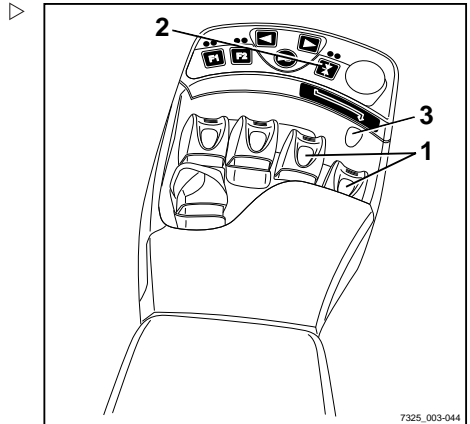

Attachments

- Press function key (4)

i NOTE

The arrow (5) under the function key indicates which operating lever is equipped with the "5th function".

The "5th function" is switched to the 3rd operating lever; see sticker (6).

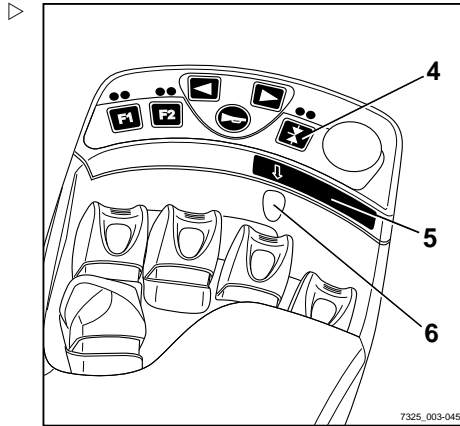

- Press function key (7)

i NOTE

The arrow (8) under the function key indicates which operating lever is equipped with the "5th function".

The "5th function" is switched to the 4th operating lever; see sticker (9).

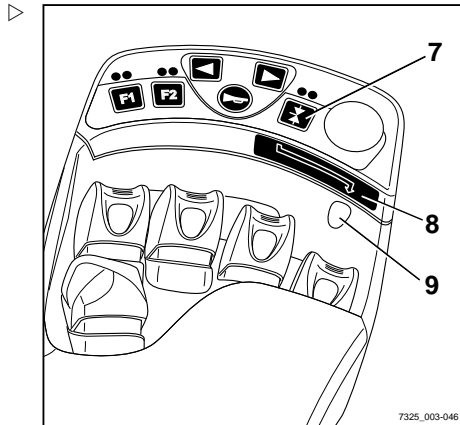

i NOTE

The movement/action of this "5th function" can be found in the operating instructions of the fitted attachment.

i NOTE

The pictograms are attached depending on the pre-assembled attachment. If an attachment with other functions is fitted, the pictograms must be checked for the correct representation and changed if necessary.

- Contact the authorised service centre if required.

- Note the following attachment functions and pictograms.

10	Move side shift frame or fork forwards/backwards
11	Move sideshift to the left/right
12	Adjust fork arms: open/close
13	Swivel lift mast or fork to the left/right
14	Release/clamp load retainer
15	Push off/pull in load
16	Turn to the left/right
17	Tip shovel over/tip shovel back

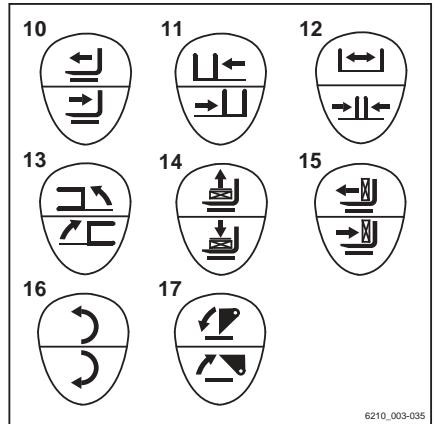

Clamp locking mechanism (variant)

This truck can be fitted with a clamp locking mechanism as a variant. This prevents the clamp from opening unintentionally if the operating function is inadvertently triggered.

⚠ DANGER

There is a risk of fatal injury from falling loads if the correct function of the clamp locking mechanism is not guaranteed!

If other attachments are used on this truck in addition to the clamp, make sure that the clamp locking mechanism function is reassigned to the corresponding operating device every time the clamp is reassembled; see the chapter entitled "Fitting attachments".

- Make sure that the additional clamp locking mechanism function is available.

Attachments

Double mini-lever

- To release the clamp locking mechanism, push the cross lever (1) forwards.

The LED for button **F2** (2) lights up as long as the clamp locking mechanism is released.

NOTE

The hydraulic function for opening the clamp is available for one second after the clamp locking mechanism is released. After one second, the clamp locking mechanism is automatically reactivated.

- To open the clamp, push the cross lever (1) forwards again.

The clamp can be closed without releasing the clamp locking mechanism.

- To close the clamp, pull the cross lever (1) backwards.

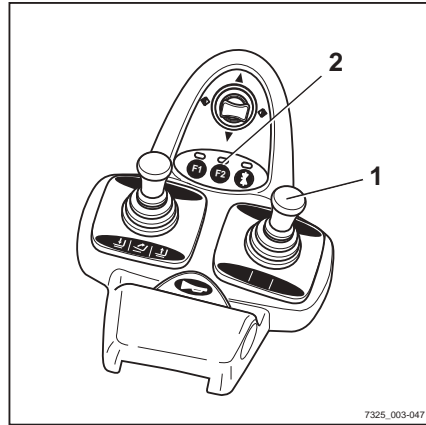
**Triple mini-lever**

- To release the clamp locking mechanism, push the operating lever (1) forwards.

The LED for button **F2** (2) lights up as long as the clamp locking mechanism is released.

NOTE

The hydraulic function for opening the clamp is available for one second after the clamp locking mechanism is released. After one second, the clamp locking mechanism is automatically reactivated.

- To open the clamp, push the operating lever (1) forwards again.

The clamp can be closed without releasing the clamp locking mechanism.

- To close the clamp, pull the operating lever (1) backwards.

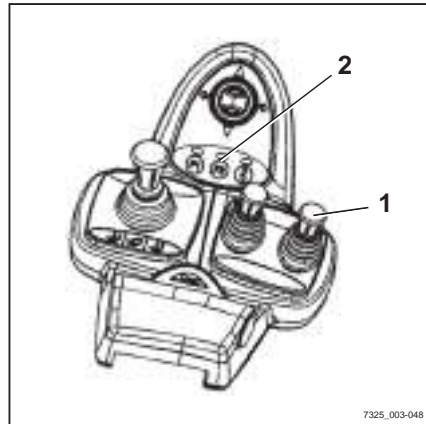

Quadruple mini-lever

- To release the clamp locking mechanism, push the operating lever (1) forwards.

The LED for button **F2** (2) lights up as long as the clamp locking mechanism is released.

i NOTE

The hydraulic function for opening the clamp is available for one second after the clamp locking mechanism is released. After one second, the clamp locking mechanism is automatically reactivated.

- To open the clamp, push the operating lever (1) forwards again.

The clamp can be closed without releasing the clamp locking mechanism.

- To close the clamp, pull the operating lever (1) backwards.

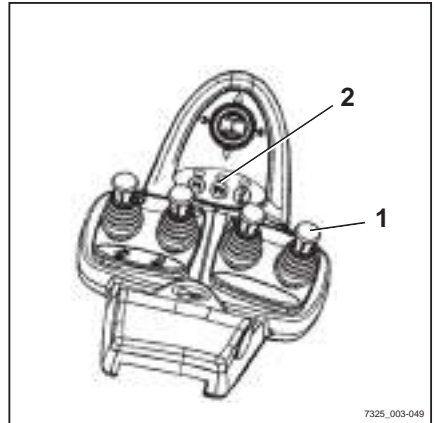

Joystick 4Plus

- To release the clamp locking mechanism, press and hold shift key **F** (3) and move the horizontal rocker button (1) to the right.
- Keep shift key **F** (3) pressed and move the horizontal rocker button (1) back to the neutral position.

The LED (2) lights up as long as the clamp locking mechanism is released.

- To open the clamp, press and hold shift key **F** (3) and move the horizontal rocker button (1) to the right.

i NOTE

The hydraulic function for opening the clamp is available for one second after the clamp locking mechanism is released. After one second, the clamp locking mechanism is automatically reactivated.

The clamp can be closed without releasing the clamp locking mechanism.

- To close the clamp, press and hold shift key **F** (3) and move the horizontal rocker button (1) to the left.

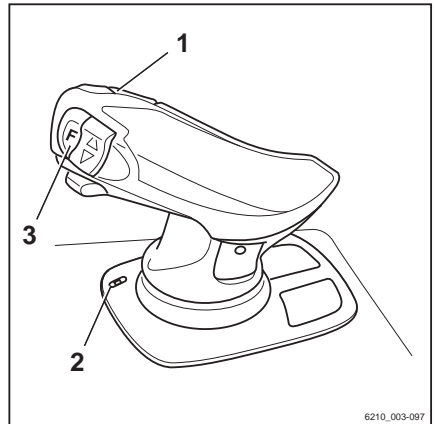

Attachments

Fingertip switch

- To release the clamp locking mechanism, push the operating lever (1) forwards.

The LED for button **F2** (2) lights up as long as the clamp locking mechanism is released.

NOTE

The hydraulic function for opening the clamp is available for one second after the clamp locking mechanism is released. After one second, the clamp locking mechanism is automatically reactivated.

- To open the clamp, push the operating lever (1) forwards again.

The clamp can be closed without releasing the clamp locking mechanism.

- To close the clamp, pull the operating lever (1) backwards.

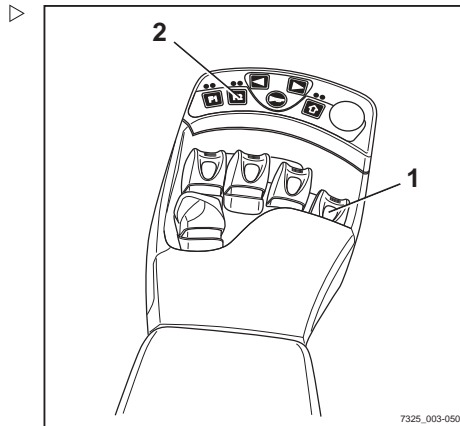

Taking up a load using attachments

WARNING

Risk of accidents!

Attachments may only be used for their intended purpose as described in the relevant operating instructions.

Drivers must be instructed in the handling of the attachments.

WARNING

Risk of accidents!

Loads may only be picked up and transported with attachments if they are securely attached. Where necessary, loads should also be secured against slipping, rolling, falling over, swinging or tipping over. Note that any change to the position of the load's centre of gravity will affect the stability of the forklift truck.

Check the capacity rating plates for the attachments or combination of attachments.

- The rating plates show the permissible values for:

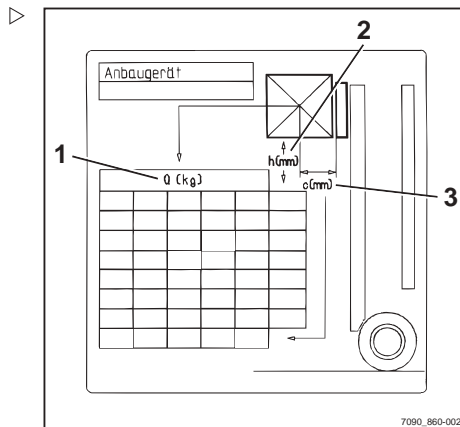

- Load capacity Q (kg) (1)
- Lift height h (mm) (2)
- Load distance C (mm) (3)

Auxiliary equipment

Switching the lighting on and off

Driving lights

- To switch on the parking light, press the button (1). ▷

The front sidelights and the rear lights light up. On the variant with StVZO (German Road Traffic Licensing Regulations) equipment, the licence plate lamp also lights up.

- To switch on the headlights, press the button (1) again.

The headlights light up in addition to the parking light.

- To switch off the driving lights, press the button (1) again.

The driving lights go out.

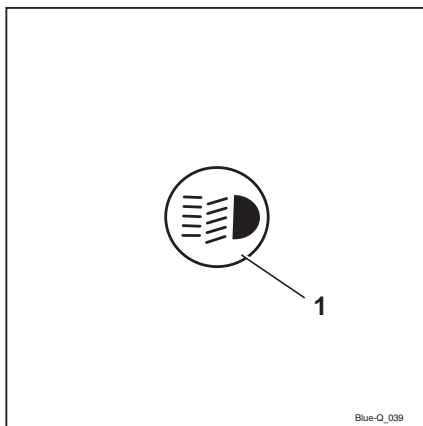

Working spotlights

- To switch on the working spotlights (front and rear), press the button (1). ▷

The working spotlights light up.

- To switch off the working spotlights, press the button (1) again.

The working spotlights go out.

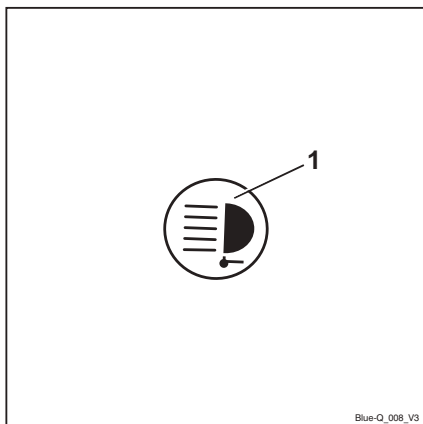

Auxiliary equipment

Switching the rotating beacon on and off

- Push the button (1) for switching on the rotating beacon. ▷

The rotating beacon symbol (2) appears on the display. The rotating beacon is switched on.

 NOTE

Pushing the button again switches the rotating beacon off again.

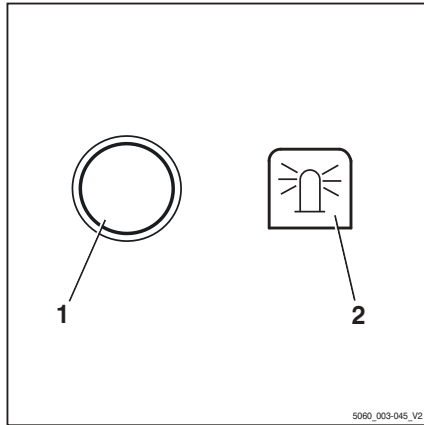
**Switching the hazard warning system on and off**

- Push the button (1) to switch on the hazard warning system. ▷

All direction indicators and indicator lights (2) flash.

 NOTE

Pushing the button again switches the hazard warning system off again.

 NOTE

The hazard warning system can also be switched on without the key switch being switched on.

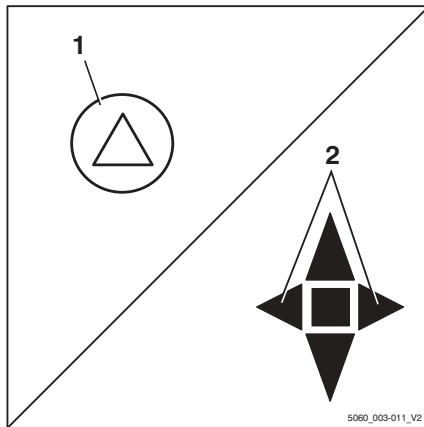

Switching direction indicators on and off

Mini-lever version

- Switch on the direction indicators by moving the corresponding drive direction/turn indicator cross lever (1) to the left or right.

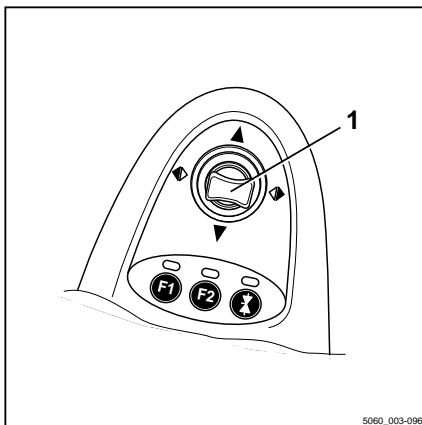

The direction indicators and the corresponding direction indicator lights (2) or (3) flash.

- Switch off the direction indicators by moving the cross lever to the centre position.

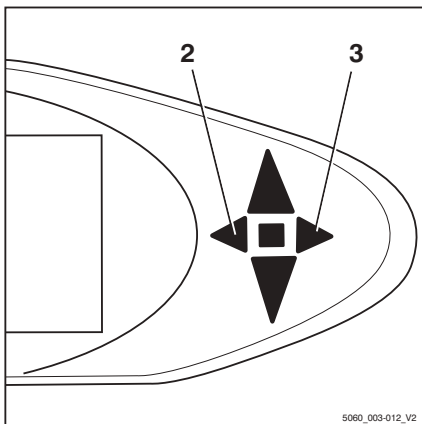

Auxiliary equipment

Fingertip version

- Switch on the direction indicators by moving the corresponding turn indicator button (1) to the left or to the right.

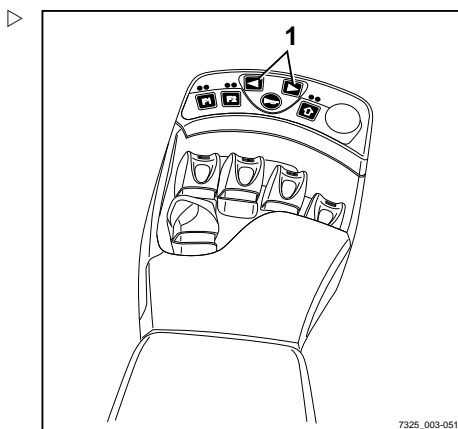

The direction indicators and the corresponding direction indicator lights (2) or (3) flash.

- Turn off the direction indicators by pushing the other turn indicator button.

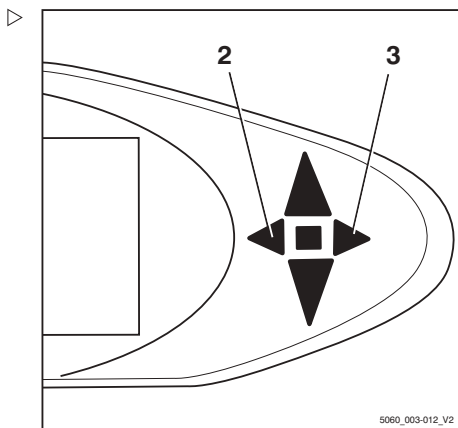

Mini-console version

- Switch on the direction indicators by moving the turn indicator switch (1) to the left or to the right.

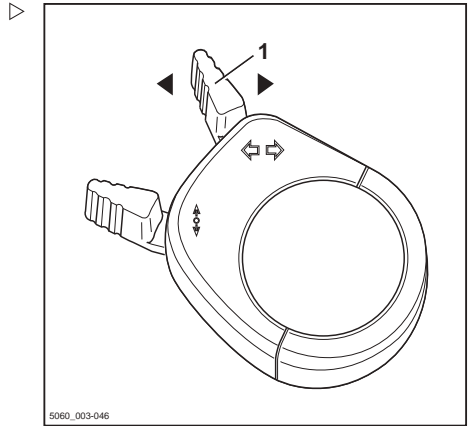

The direction indicators and the corresponding turn indicator displays (2) or (3) flash.

- Switch off the direction indicators by moving the turn indicator switch to the centre position.

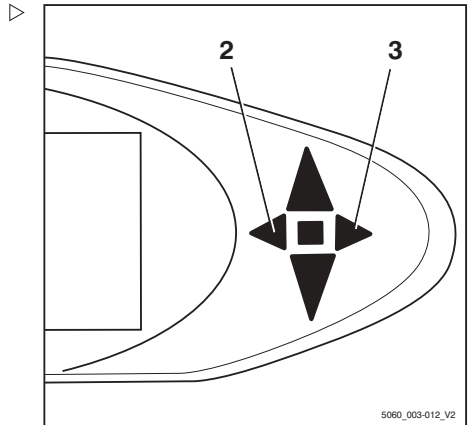

Auxiliary equipment

Switching the double working spotlights on and off.

The double working spotlights are fitted up on the front right and left on the overhead guard. Each double working spotlight consists of an upper working spotlight (2) and a lower working spotlight (3). The upper working spotlight illuminates the working area at great lift heights, the lower working spotlight illuminates the working area directly in front of the truck.

Depending on the equipment, the upper working spotlights can be switched on/off automatically or manually.

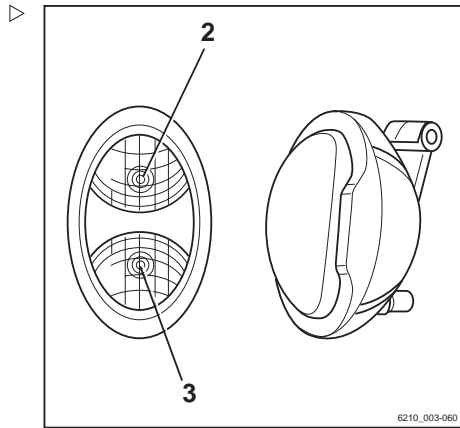

Switching the upper working spotlights on/off manually

i NOTE

The upper working spotlights can be switched on/off independently of the lower working spotlights. For information on switching the lower working spotlights on, see the "Switching lighting on and off" chapter.

i NOTE

This function is not available if the truck is equipped with rear window heating.

- Turn the key switch to position "I".

- Press button (1).

i NOTE

Pressing the button again switches the working spotlights off again.

Switching the upper working spotlights on/off automatically

- Turn the key switch to position "I".
- For information on switching on working spotlights, see the "Switching lighting on and off" chapter.

The lower working spotlights light up.

The upper working spotlights are switched on automatically when the lift mast is lifted for a period of at least two seconds.

i NOTE

In these two seconds, a maximum of two lifts can take place so that the working spotlights do not switch on each time a precise adjustment is made. If more lifts are carried out during this time, the upper working spotlights will remain switched off.

i NOTE

The upper working spotlights are switched off automatically when the truck is driven for longer than one second and faster than 2.1 km/h.

Lift-height-controlled switching on/off of the upper working spotlights

i NOTE

This equipment is available only if a proximity switch is fitted to the lift mast to record a particular lift height of the fork carriage on the lift mast.

- Turn the key switch to position "I".
- Switch on the working spotlights.

The lower working spotlights light up.

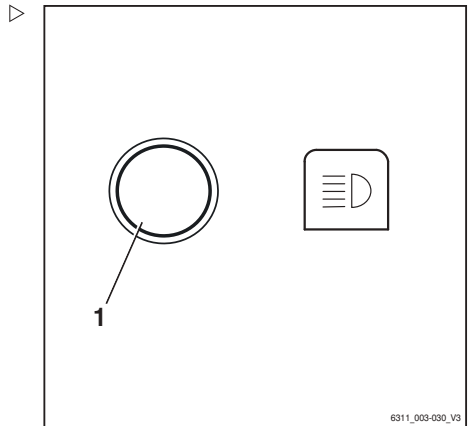

Auxiliary equipment

The upper working spotlights are switched on by the proximity switch when the fork carriage reaches or exceeds the preset lift height.

The upper working spotlights are switched off by the proximity switch when the fork carriage falls below the preset lift height again.

⚠ CAUTION

Possible component damage caused by collision if the proximity switch is set incorrectly.

- The proximity switch may be adjusted by trained personnel.
- Inform the relevant service centre.

STILL SafetyLight (variant)

The STILL SafetyLight is a visual warning unit to enable early detection of trucks in driving areas with low visibility (such as drive lanes, high racks), as well as at blind junctions.

The STILL SafetyLight is mounted on a support on the overhead guard such that it is not affected by jolts and vibrations. It projects one or more light blue light spots approximately 5 meters in front of or behind the truck and thus warns others about the approaching truck.



⚠ WARNING

Danger of damage to eyes when looking into the STILL SafetyLight.

Do not look into the STILL SafetyLight.

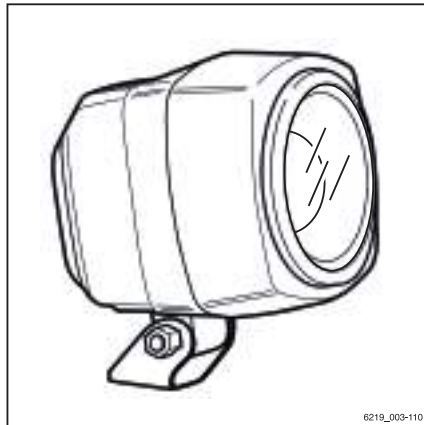

6219_003-110

i NOTE

If the truck is to be operated on public roads, the STILL SafetyLight must be switched off.

Operating the windscreen wiper/washer

- Push button (1) to actuate the front windscreen wiper/washer (variant)
- Push button (2) to actuate the rear windscreen wiper/washer (variant)

Repeated pressing of the respective button switches between the operating stages in the sequence specified shown below.

Button actuation	Operating stage
	Off
1st time	on
2nd time	Interval
3rd time + hold	Washer
4th time	Off

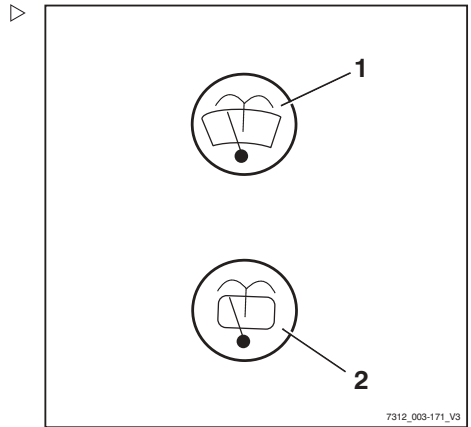

Filling the washer system

- Open the filler cap (1) of the washer system (variant).
- Fill the washer reservoir with washer fluid containing anti-freeze, according to the maintenance data table; see ⇒ Chapter "Maintenance data table", P. 5-314.

⚠ CAUTION

Components may become damaged due to the effects of frost!

Water expands when it freezes. If there is no anti-freeze in the washer system (variant), the system may become damaged due to the accumulation of ice in freezing conditions.

- Always use washer fluid containing anti-freeze.
- Close the filler cap.
- Operate washer system until washer fluid is discharged from the spray nozzles.

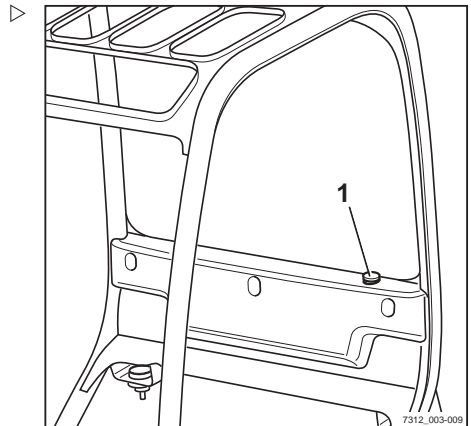

FleetManager (variant)

FleetManager is an equipment variant and can be fitted to the truck in different versions.

Auxiliary equipment

The description and operation information can be found in the separate operating instructions for the corresponding FleetManager versions.

Shock recognition (variant)

The shock recognition is an equipment variant of the FleetManager (variant) in which an acceleration sensor is installed in the truck. The acceleration sensor records data arising from rapid accelerations or decelerations of the truck, e.g. in the event of an accident. This data can be electronically read out and evaluated.

- If you have any questions, please contact your authorised service centre.

Cruise control (variant)

Using the cruise control function, the driver can save the speed in forwards travel when it is > 6.0 km/h by pressing a button, and continue driving without actuating the accelerator pedal.



NOTE

The cruise control function cannot be used for reverse travel or when travelling at speeds of < 6.0 km/h.

Depending on the truck equipment, the cruise control can be switched on and off via the drive direction switch or the display and operating unit.

Switching on and off via the drive direction switch (1).

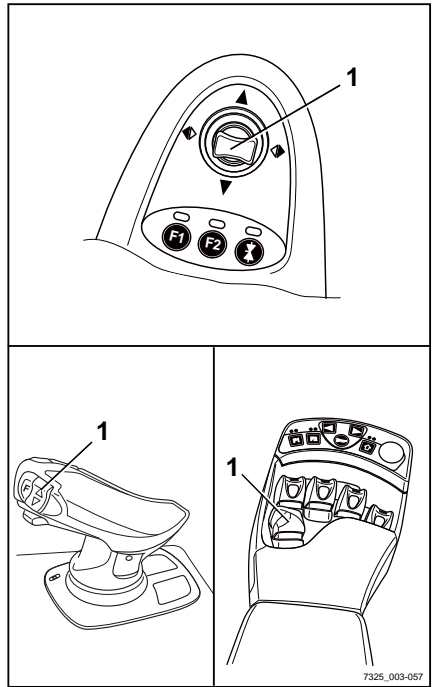

Switching on and off via the display and operating unit.

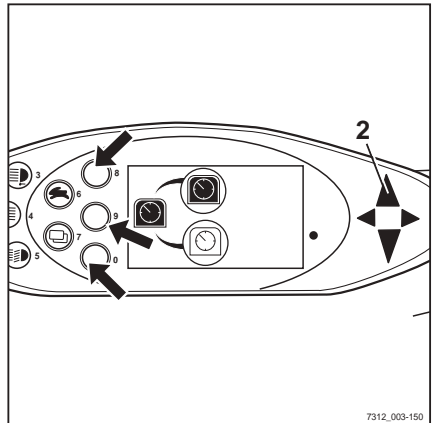

Switching on cruise control

⚠ WARNING

Risk of accident from failing to adjust speed!

Driving at excessive speeds can cause accidents, e.g. the truck could tip over when cornering.

- Adjust speed along the entire distance being travelled
- Pay particular attention to cornering speed
- Observe safety regulations when driving
- Observe the special behaviour of the cruise control function and the dangers associated with it

- Start drive mode.
- Accelerate the truck to the required speed (at least 6.0 km/h)

Auxiliary equipment

- Re-actuate the drive direction switch (1) for forward travel for at least one second, or press the corresponding button on the display and operating unit.

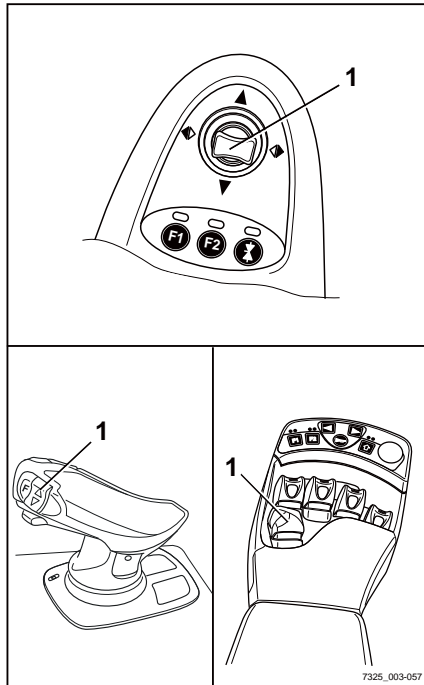

The current speed is saved. The forwards drive direction indicator (2) flashes.

The cruise control symbol on the display and operating unit is shown in black.

- Remove your foot from the accelerator pedal.

The truck continues to drive at the selected speed until the cruise control function is switched off again.

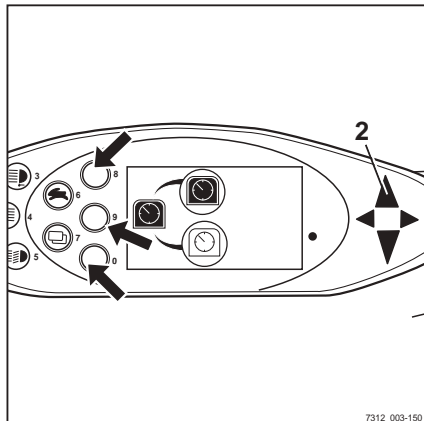

Switching off cruise control

The cruise control function is switched off by means of one of the following actions:

- Actuate the foot brake
- Actuate the parking brake
- Actuate the accelerator pedal
- Move the drive direction switch (1) into the neutral position or reverse
- Actuate the corresponding button (see arrows, previous picture) on the display and operating unit

i NOTE

If the seat switch is not actuated, the truck's cruise control function and drive function are switched off.

The accelerator pedal can be used to switch off the cruise control function, depending on which function type is programmed:

- Type 1:
Even slightly depressing the accelerator pedal switches off the cruise control function
- Type 2:
To switch off the cruise control function, the accelerator pedal must be depressed at least as far as it was when saving the speed

– Switch off cruise control

The drive direction indicator (2) lights up.

The cruise control symbol on the display and operating unit is shown in white.

i NOTE

If the truck is configured with automatic functions that reduce the driving speed to 6 km/h or less in certain situations, then these functions will also switch the cruise control off automatically.

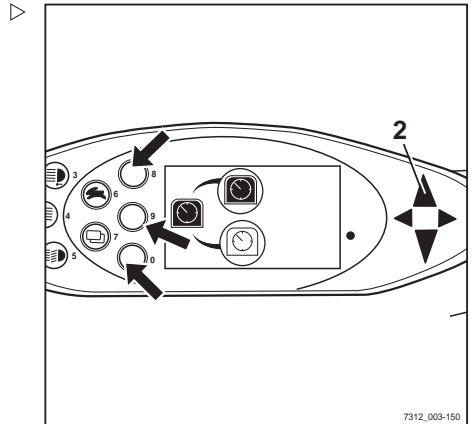
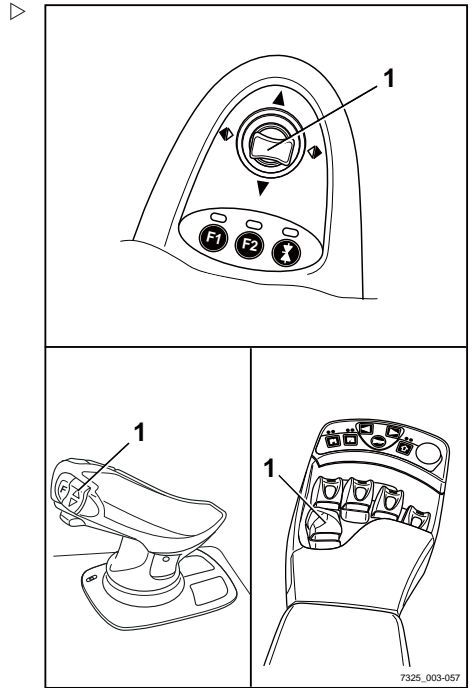

Auxiliary equipment

Driver restraint systems (variants)

Different driver restraint systems are available as variants for this truck. The description and operation for these systems can be found in the separate "Driver restraint systems" operating instructions.

Cab

Opening the cab door

⚠ DANGER

There is risk of damage caused by collision if the cab door opens while driving.

- The cab door must be securely engaged in the detent position.

Opening the cab door from the outside:

- Insert the key in the door lock (1), unlock and remove the key again.
- Pull the door handle (2) and release the door lock.
- Open the cab door (3) by pulling outwards.

Opening the cab door from the inside:

- Take hold of the handlebar (4) and latch (5).
- Press the latch in and push the cab door outwards.

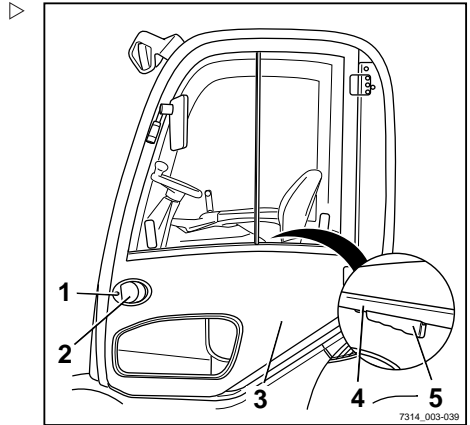

Cab

Closing the cab door**⚠ DANGER**

There is risk of damage caused by collision if the cab door opens while driving.

- The cab door must be securely engaged in the detent position.

Closing the cab door from the outside:

- Push the cab door (2) inwards until the door lock engages.
- Make sure that the cab door is fully closed.

Closing the cab door from the inside:

- Take hold of the handlebar (1).
- Pull the cab door inwards until the door lock engages.
- Make sure that the cab door is fully closed.

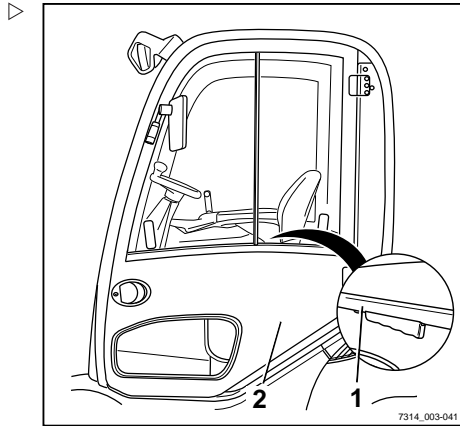
**Opening the side windows****⚠ WARNING**

There is risk of crushing between the window frame and side window caused by the side windows slipping inadvertently during travel.

- Make sure that the handle engages securely in the corresponding stop slot.

Opening the rear side window:

- Press the handle (2) together and slide the rear side window (1) forwards.
- Make sure that the handle engages in the stop slot (3).

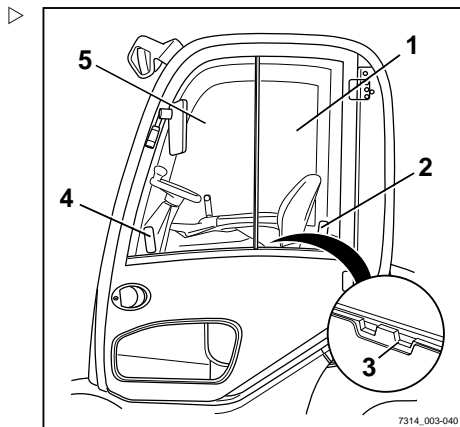
**Opening the front side window:**

- Press the handle (4) together and slide the front side window (5) to the rear.
- Make sure that the handle engages in the stop slot (3).

Closing the side windows

▲ WARNING

There is risk of crushing between the window frame and side window caused by the side windows slipping inadvertently during travel.

- Make sure that the handle engages securely in the corresponding stop slot.

Closing the rear side window:

- Press the handle (2) together and pull the rear side window (1) to the rear.
- Make sure that the handle engages in the stop slot (3).

Closing the front side window:

- Press the handle (4) together and slide the front side window (5) forwards.
- Make sure that the handle engages in the stop slot (3).

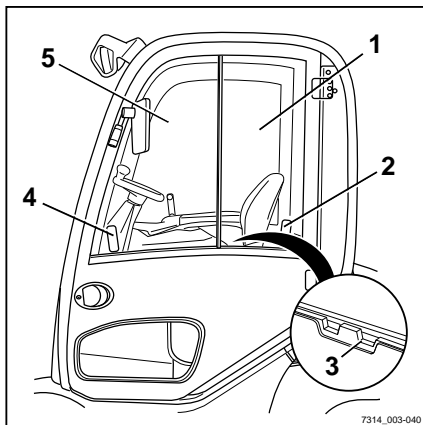

Operating the interior lighting

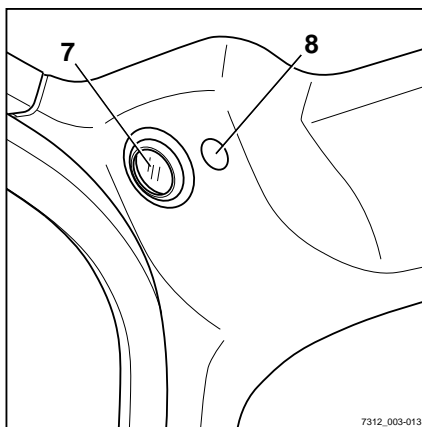

- Switch the interior lighting (7) on or off using the switch (8) or button (1). ▷

The "interior lighting" symbol (2) appears in the display.

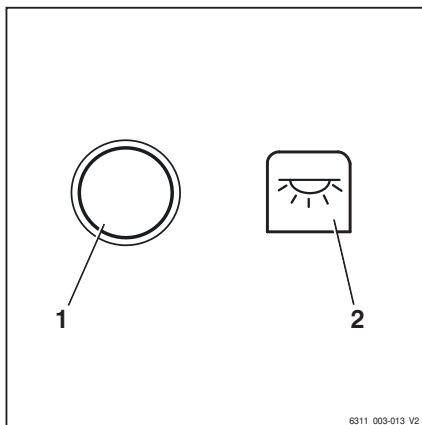

Operating the rear window heating

- Switch the rear window heating on or off with button (1).

The "rear window heating" symbol (2) appears in the display.

NOTE

The rear window heating will switch off automatically after approx. 10 minutes or after pressing the switch again.

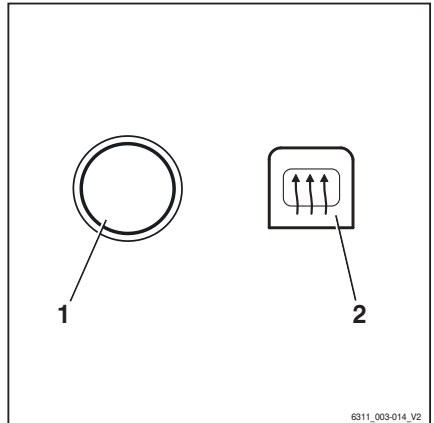

Radio (variant)

The radio (1) and the loudspeakers (2) are an equipment variant. If the truck is equipped with a radio and loudspeakers, they are integrated into the roof lining.

The description and operation can be found in the separate operating instructions for the radio.

WARNING

The driver's attention is adversely affected by operating the radio or listening to excessive volume while driving or handling loads. There is a risk of accident!

- Do not use the radio when driving or when handling loads.
- Set the radio volume so that you can still hear warning signals.

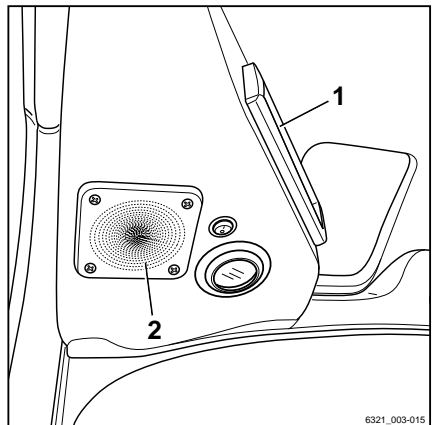

Heating system



⚠ DANGER

Risk of explosion!

Do not expose spray cans or gas cartridges to the flow of hot air.

The heater should not be operated near storage rooms or similar facilities where fuel vapours or coal, wood or grain dust could accumulate.

Switching on the blower

- To switch on the blower, turn on the blower switch (1).

The blower runs at the speed level set at the switch.

Switching on the heating system



⚠ DANGER

Risk of fire!

Do not cover the heater!



⚠ DANGER

Risk of burns!

Do not touch housing during operation!

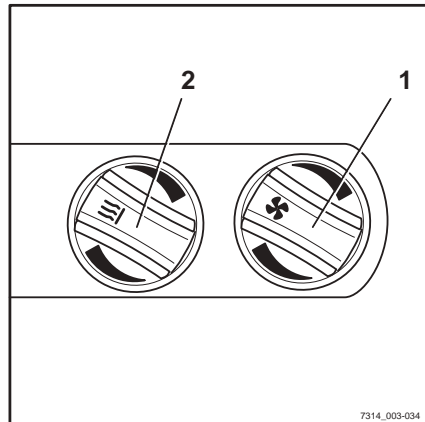

i NOTE

Only switch on the heating system when the blower is running.

- To switch on the heating system, turn on the heating switch (2).

The heating system is in operation. The air is heated up to the heater power set at the variable switch (2).

Air circulation

- To allow the air to circulate, open the air circulation vent (3) (50% air circulation).

Defrost

- To defrost the windscreen, close the footwell vent (4) and direct both front air vents towards the windscreen.
- Turn the blower to the highest setting.

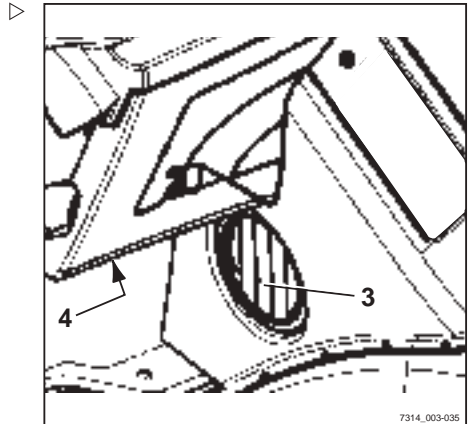

Push-up roof window (variant)

⚠ WARNING

Risk of crushing!

- When closing the roof window, do not reach between the roof window and the overhead guard.
- Do not reach in to touch components as they are being closed.

The push-up roof window (1) is an equipment variant.

- To unlock and open the roof window, rotate the handle (2) in an anti-clockwise direction and use it to push the roof window upwards.

The roof window is held in the open position by means of gas springs (3).

- To close and lock the roof window, pull the roof window downwards using the handle and rotate the handle in a clockwise direction

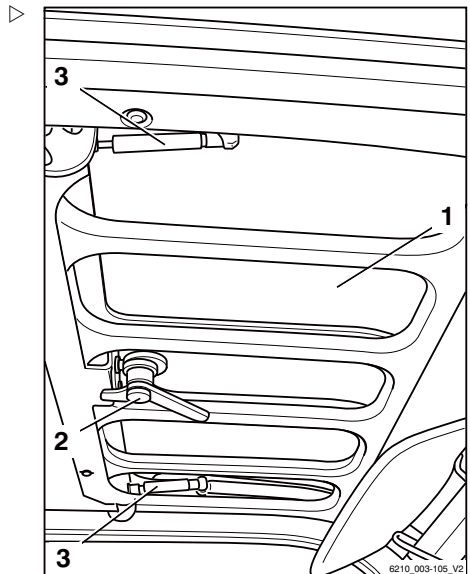

Cab

Clipboard (variant)

The clipboard (1) with reading lamp (2) is an equipment variant.

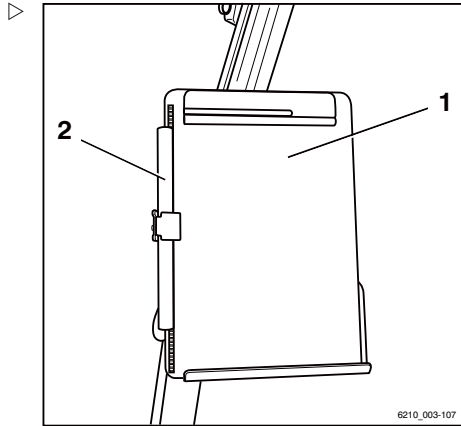

Trailer operation

Towed load

⚠ DANGER

There is an increased risk of accident when using a trailer.

Using a trailer changes the truck handling characteristics. When towing, operate the truck such that the trailer train can be safely driven and braked at all times. The maximum permissible speed when towing is 5 km/h.

- Do not exceed the permissible speed of 5 km/h.
- Do not couple the truck in front of rail vehicles.
- The truck must not be used to push any kind of trolley.
- It must be possible to drive and brake at all times.

⚠ CAUTION

Risk of damage to components!

The maximum towed load for occasional towing is the rated capacity specified on the nameplate. Overloading can lead to component damage on the truck. The sum of the actual towed load and the actual load on the fork must not exceed the rated capacity. If the existing towed load corresponds to the rated capacity of the truck, no load may be transported on the fork at the same time. The load can be distributed between the fork and the trailer.

- Check the load distribution and adjust it to correspond to the rated capacity.
- Observe the permissible rigidity value of the tow coupling.

⚠ CAUTION

Risk of damage to components!

The maximum towed load only applies when towing unbraked trailers on a level surface (maximum deviation +/- 1%) and on firm ground. The towed load must be reduced if towing on gradients. If necessary, notify the authorised service centre of the application conditions. The service centre will provide the required data.

- Inform the authorised service centre.

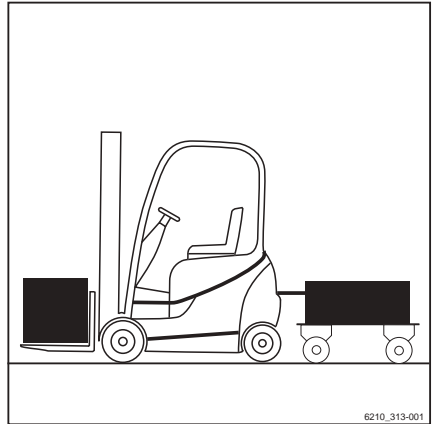

6210_313-001

Trailer operation

⚠ CAUTION

Risk of damage to components!

A support load is not permitted.

- Do not use trailers with tillers supported by the tow coupling.

This truck is suitable for the occasional towing of trailers. If the truck is equipped with a towing device, this occasional towing must not exceed 2% of the daily operating time. If the truck is to be used for towing on a more regular basis, the manufacturer should be consulted.

Coupling pin in the counterweight

Coupling the trailer

⚠ DANGER

If you briefly leave the truck to couple or uncouple the trailer, there is a risk to life caused by the truck rolling away and running you over.

- Apply the parking brake.
 - Lower the forks to the ground.
 - Switch off the key switch and remove the key.
-
- Take measures to prevent the trailer from rolling away, e.g. use wheel chocks (1).
 - Push the coupling pin (2) down, turn 90° and pull out.

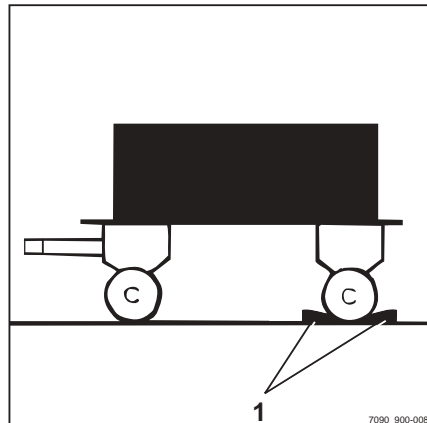

- Adjust the tiller height.

⚠ DANGER

People can become trapped between the truck and trailer.

When hooking up, ensure that no one is between the truck and trailer.

- Slowly move the truck backwards.
- By moving the truck back, introduce the tiller into the recess (3) in the counterweight.

⚠ DANGER

In the event of loss or destruction of the coupling pin or the securing bush during towing, the trailer works loose and becomes uncontrollable, meaning there is a risk of accident!

- Use only original coupling pins that have been checked carefully.
 - Ensure that the coupling pin is correctly inserted and secured.
-
- Insert the coupling pin into the counterweight, press downwards against the spring pressure and turn 90° (the coupling pin is locked in this position).
 - Remove any items used to prevent the trailer from rolling away.

Uncoupling the trailer

- Take measures to prevent the trailer from rolling away, e.g. use wheel chocks.
- Push the coupling pin (2) down, turn 90° and pull out.
- Slowly move the truck forwards and guide the tow-bar eye completely out of the counterweight.
- Insert the coupling pin into the counterweight, press downwards against the spring pressure and turn 90° (the coupling pin is locked in this position).

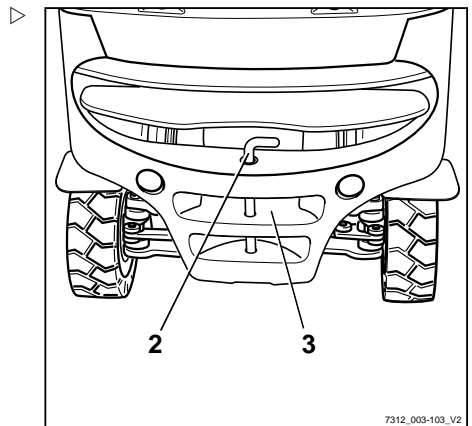
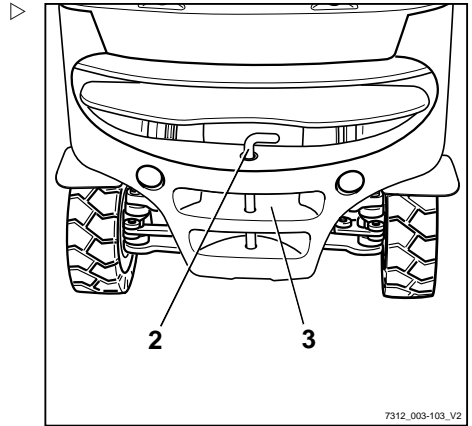

Trailer operation

Automatic tow coupling**⚠ DANGER**

People may be trapped between the truck and trailer.

When hooking up, ensure that no one is between the truck and trailer.

⚠ DANGER

Never jack up the truck on the tow coupling or use it for crane lifting. The tow coupling is not designed for this and could be deformed or damaged. This could cause the truck to fall, with potentially fatal consequences!

- Use the tow coupling only for towing.
 - For jacking up and crane loading, use only the designated lifting points.
-

⚠ DANGER

The tow coupling is not designed to support loads and could become deformed or destroyed. This could cause the supported load to fall, with potentially fatal consequences!

- The tow coupling should be subjected only to horizontal loads, i.e. the tiller must be horizontal.
-

⚠ DANGER

If you briefly leave the truck to couple or uncouple the trailer, there is a risk to life caused by the truck rolling away and running you over.

- Apply the parking brake.
 - Lower the forks to the ground.
 - Switch off the key switch and remove the key.
-

⚠ WARNING

Never reach between the coupling pins and the towing jaws. If the component moves suddenly there is a risk of injury!

- To release the coupling pin, actuate the corresponding lever or use a suitable device (e.g. assembly lever).
 - When not in use, close the automatic tow coupling.
-

⚠ WARNING

Risk of damage due to component collision.

A truck with tow coupling needs more room for manoeuvring due to its overhang. The tow coupling can damage the racking or the tow coupling itself when manoeuvring. If there is a collision with the tow coupling, test the tow coupling for damage such as cracks. A damaged tow coupling must not be used again.

- Always manoeuvre carefully and with sufficient room.
- In the case of a collision, test the tow coupling for damage.
- Replace tow coupling if damaged, if necessary contact the authorised service centre.

⚠ WARNING

Risk of damage to the tow bar eye or tiller!

Due to the truck's rear wheel steering, the side slewing angle of the tiller may not be adequate. The coupling or the tiller may be damaged! The tow bar eye of the tiller must fit the tow coupling in terms of shape and size.

- Ensure that the tow bar eye and tiller fit correctly.
- Avoid sharp cornering.
- Exercise care when travelling and manoeuvring in reverse.

⚠ WARNING

Risk of component damage if the tiller in the tow coupling is tilted!

The tiller should be kept as horizontal as possible when towing. This ensures that the rotation range is sufficient at the top and bottom. The authorised service centre can adjust the assembly height for the tow coupling to the tiller height if necessary.

- Make sure that the tiller is level.
- To change the coupling height, contact the authorised service centre.

Trailer operation

Coupling model RO*243

i NOTE

Tow coupling RO 243 is intended for a tow-bar eye in accordance with DIN 74054 (bore diameter: 40 mm).

- Take measures to prevent the trailer from rolling away, e.g. use wheel chocks (1).
- Adjust the tow bar eye of the tiller so that it is at the centre of the towing jaws.

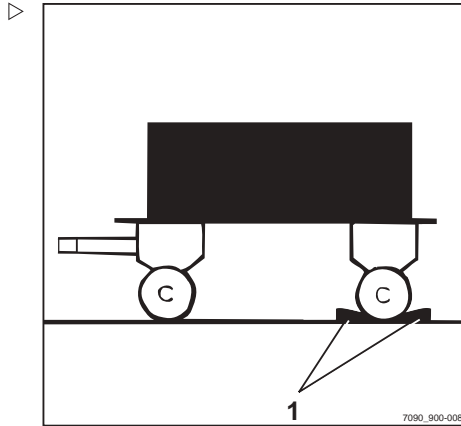

- Pull out the safety handle (3).
- Push the hand lever (2) upwards.

⚠ DANGER

Persons may become trapped between the truck and trailer.

When hooking up, ensure that no one is between the truck and trailer.

⚠ CAUTION

When being coupled, the tow-bar eye must engage in the middle of the coupling jaw. Failure to follow these instructions could result in damage to the coupling jaw or to the tow-bar eye!

- Ensure that the tow-bar eye enters the coupling jaw centrally.

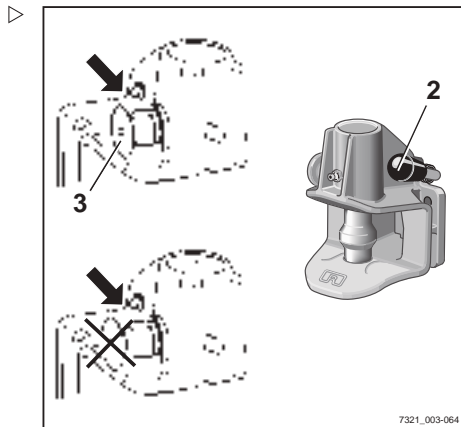

- Slowly move the truck back.

⚠ DANGER

If the coupling pin drops out during towing, the trailer will work loose and can no longer be controlled. There is a risk of accident!

A protruding safety handle means that the tow bar eye has not been coupled correctly. The trailer must not be towed in this condition.

- Ensure that the safety handle is flush with the securing bush.
- If the safety handle protrudes, repeat the coupling process.
- Remove any items used to prevent the trailer from rolling away.

- Tow the trailer.

Closing model RO*243 by hand

⚠ DANGER

Risk of injury from hand becoming trapped!

Do not reach into the coupling pin area. If, for example, a tow rope is to be secured in the tow coupling, use only a suitable device to close the tow coupling (e.g. assembly lever).

- Use a suitable device (e.g. assembly lever) to push the coupling pin up.

The coupling pin is released from the latch and the tow coupling then closes automatically.

Uncoupling model RO*243

- Take measures to prevent the trailer from rolling away, e.g. use wheel chocks.
- Pull out the safety handle (3).
- Push the hand lever (2) upwards.
- Slowly drive the truck forwards until the tow-bar eye and towing jaws are disconnected.
- Close the tow coupling by hand.

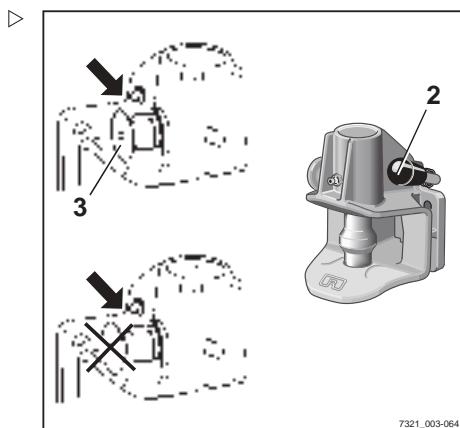

Trailer operation

Coupling model RO*244 A

i NOTE

Trailer coupling RO 244 is intended for a tow bar eye in accordance with DIN 74054 (bore diameter 40 mm) or DIN 8454 (bore diameter 35 mm).

- Take measures to prevent the trailer from rolling away, e.g. use wheel chocks.
- Adjust the tow bar eye of the tiller so that it is at the centre of the towing jaws.
- Push the hand lever (2) upwards until it snaps into place.

The tow coupling is opened.

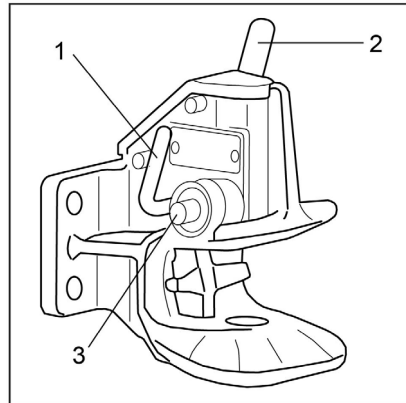
**⚠ DANGER**

People can become trapped between the truck and trailer!

When hooking up, ensure that no one is between the truck and trailer.

⚠ CAUTION

When being coupled, the tow-bar eye must engage in the middle of the coupling jaw. Failure to follow these instructions could result in damage to the coupling jaw or to the tow-bar eye!

- Ensure that the tow-bar eye enters the coupling jaw centrally.
- Move the truck back slowly until the tow bar eye is inserted centrally into the coupling jaw of the tow coupling and the coupling pin engages.

i NOTE

The coupling pin is correctly engaged if the control pin (3) does not protrude out of its guide.

⚠ DANGER

If the coupling pin drops out during towing, the trailer will work loose and can no longer be controlled. There is a risk of accident!

The control pin (3) must not protrude out of its guide.

- Ensure that the coupling pin is engaged correctly.

If the coupling pin is not correctly engaged:

- Remove any items used to prevent the trailer from rolling away.
- Move the truck with the trailer forwards approx. 1 m and then move it back slightly.
- On the coupling pin, check again that the control pin does not protrude out of its guide.

-
- Remove any items used to prevent the trailer from rolling away.

- Tow the trailer.

Closing model RO*244 A by hand**⚠ DANGER**

Risk of injury from hand becoming trapped!

Do not reach into the coupling pin area. If, for example, a tow rope is to be secured in the tow coupling, only actuate the tow coupling via the closing lever (1).

- Press the closing lever (1) downwards as far as it will go.

The tow coupling is closed.

Uncoupling model RO*244 A

- Take measures to prevent the trailer from rolling away, e.g. use wheel chocks.
- Push the hand lever (2) upwards until it snaps into place.

The tow coupling is opened.

- Slowly drive the truck forwards until the tow-bar eye and towing jaws are disconnected.
- Close the tow coupling by actuating the closing lever (1).

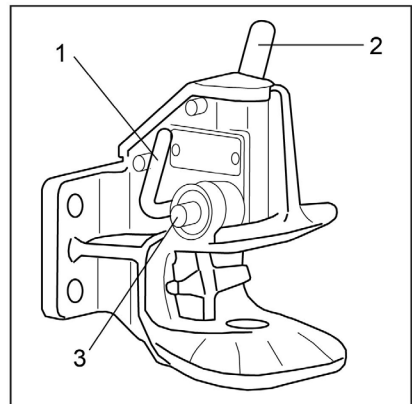

Trailer operation

i NOTE

To protect the lower coupling pin bush against contamination, always keep the tow coupling closed.

Coupling model RO*245**i** NOTE

Trailer coupling RO 245 is intended for a tow-bar eye in accordance with DIN 74054 (bore diameter 40 mm) or DIN 8454 (bore diameter 35 mm).

- Take measures to prevent the trailer from rolling away, e.g. use wheel chocks.
- Adjust the tow bar eye of the tiller so that it is at the centre of the towing jaws.
- Push the hand lever (5) upwards.
- The tow coupling is opened.

⚠ DANGER

People can become trapped between the truck and trailer!

When hooking up, ensure that no one is between the truck and trailer.

- Slowly move the truck back.

⚠ DANGER

If the coupling pin drops out during towing, the trailer will work loose and can no longer be controlled. There is a risk of accident!

A protruding safety handle means that the tow bar eye has not been coupled correctly. The trailer must not be towed in this condition.

- Make sure that the control pin does not protrude from the control bush.
 - Repeat the coupling process if necessary.
-
- Remove any items used to prevent the trailer from rolling away.
 - Tow the trailer.

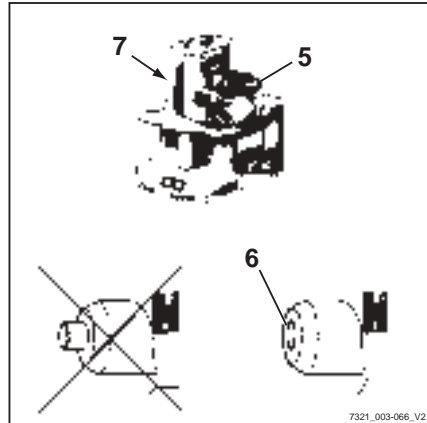

Uncoupling model RO*245

- Take measures to prevent the trailer from rolling away, e.g. use wheel chocks.
- Push the hand lever (5) upwards.
- Slowly drive the truck forwards until the tow-bar eye and towing jaws are disconnected.
- Push the closing lever (7) on the left side of the tow coupling down as far as it will go.

The tow coupling is closed.

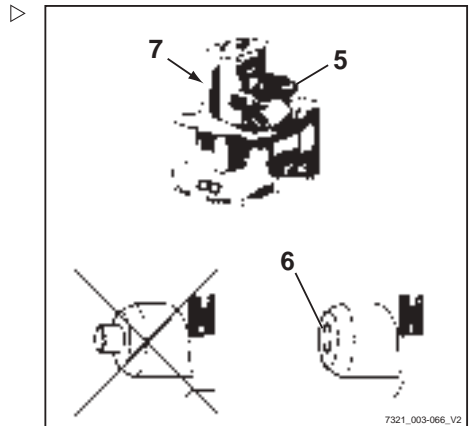

7321_003-066_V2

Coupling model RO*841

i NOTE

Tow coupling RO 841 is intended for a tow-bar eye in accordance with DIN 74054 (bore diameter 40 mm).

- Take measures to prevent the trailer from rolling away, e.g. use wheel chocks.
- Push the hand lever (7) upwards until it snaps into place.

⚠ DANGER

People may be trapped between truck and trailer.

When hooking up, ensure that no one is between the truck and trailer.

⚠ CAUTION

When being coupled, the tow-bar eye must engage in the middle of the coupling jaw. Failure to follow these instructions could result in damage to the coupling jaw or to the tow-bar eye!

- Ensure that the tow-bar eye enters the coupling jaw centrally.
- Slowly move the truck back.

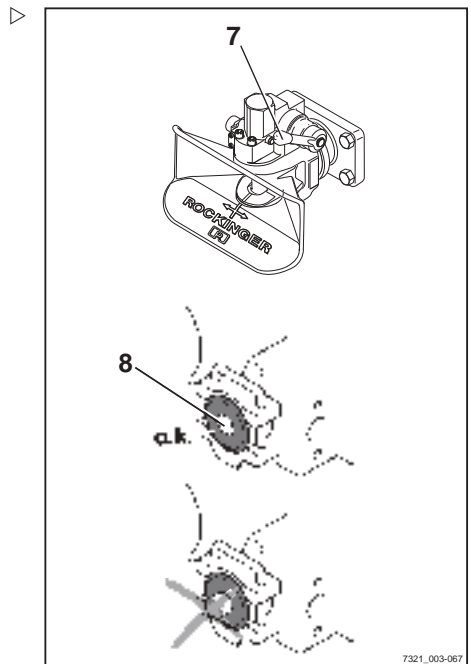

7321_003-067

Trailer operation

⚠ DANGER

If the coupling pin drops out during towing, the trailer will work loose and can no longer be controlled. There is a risk of accident!

A protruding safety handle means that the tow bar eye has not been coupled correctly. The trailer must not be towed in this condition.

- Make sure that the control pin does not protrude from the control bush.
 - Repeat the coupling process if necessary.
-
- Remove any items used to prevent the trailer from rolling away.
 - Tow the trailer.

Uncoupling model RO*841

- Take measures to prevent the trailer from rolling away, e.g. use wheel chocks.
- Push the hand lever (7) upwards.
- Slowly drive the truck forwards until the tow-bar eye and towing jaws are disconnected.
- Close the tow coupling.

Towing trailers

- Drivers who are towing a trailer for the first time must practise driving with a trailer in a suitable area.
- When passing through narrow road areas (entrances, gates etc.), observe the dimensions of the trailer and load.
- When towing multiple trailers, ensure a sufficient minimum distance to fixed installations when turning and cornering.

The permissible length of the trailer trains depends on the roadways to be driven and may need to be determined during the test drive.

It is the responsibility of the operating company to instruct the drivers regarding the permissible number of trailers and, where required, any additional speed reductions on individual sections of the route.

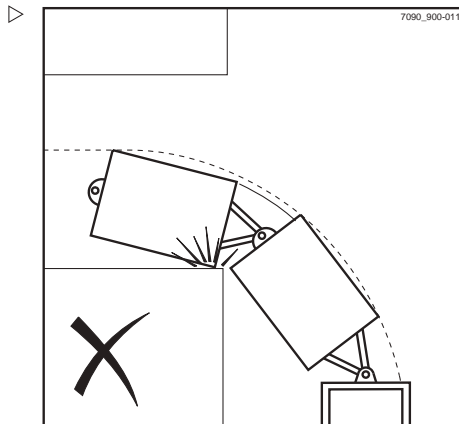

 **NOTE**

Please observe the definition of the following responsible persons: "operating company" and "driver".

Display messages

Display messages

Display content

On the display of the display-operating unit, event-related messages may appear due to certain truck conditions.

The following types of message may appear individually or in combination:

- A graphic symbol (2)
- The message (3)
- An error code (4) consisting of a letter and a four-digit number



NOTE

Each time a message appears, the "Malfunction" display (1) also lights up.

Messages are always shown repeatedly and for a certain period of time, according to the event.

In the case of successive events, the respective messages are displayed one after another on the display.

After a few seconds, the display will alternate between the last shown operating display and the message.

The frequency of alternation depends on the type of event.

- If a message appears, follow these operating instructions.

Once the event is remedied, the message will disappear.

If a malfunction continues to occur, the message will continue to appear.

- Park the truck safely.
- Inform the authorised service centre.

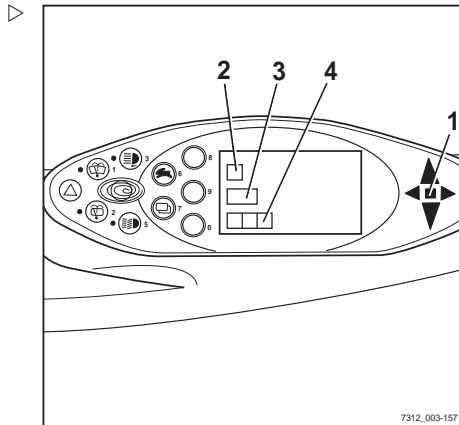

Error code table

The table gives an overview of possible displays. In the "Comment" column you will find information on how to proceed should any of these messages be displayed.

Message text/ Error code	Comment
OVERHEATING A5022	Traction motor(s) is/are too hot. 1st phase: regulation of acceleration and speed. 2nd phase: limitation of phase current in converter (emergency driving function is retained). The error automatically disappears as soon as the temperature is below the limit. If the error occurs frequently, notify your authorised service centre.
ACCELERATOR A3002 A3003 A3004 A3005 A3006 A3007 A3505	Sensor fault, truck cannot be driven. Notify your authorised service centre.
ACCELERATOR A3008	Accelerator voltages (for dual pedal) do not match; truck cannot be driven. Notify your authorised service centre.
ACCELERATOR A3811	Accelerator configuration is invalid; truck cannot be driven. Notify your authorised service centre.
BRAKE SENSOR A3016 A3017	Sensor fault; truck can only be driven at emergency mode speed. Notify your authorised service centre.
BRAKE SENSOR A3035	Brake fluid level too low or switch defective; truck can only be driven at the emergency mode speed. Notify your authorised service centre.
CONFIGURATION A2111	Parameterisation error or defective printed circuit board; drive unit and hydraulic drive not functioning. Notify your authorised service centre.
CONFIGURATION A3801	Parameterisation error; drive unit and hydraulic drive not functioning. Notify your authorised service centre.
CONFIGURATION A3812	Drive program parameters are outside the permitted range. The drive program parameters are limited internally. Notify your authorised service centre.

Display messages

Message text/ Error code	Comment
SEAT SWITCH A3027	Seat switch has not been operated for approx. 8 hours. Truck can possibly still be driven at a reduced speed and with reduced lifting capacity. Stand up briefly and then sit down again. If this does not resolve the problem, contact your authorised service centre.
STEERING A3215	Sensor fault; truck moves at emergency mode speed. Notify your authorised service centre.
DRIVE DIRECTION A3020	Switch error; no or limited drive unit function. Notify your authorised service centre.
LIFTING A3102 A3103	Sensor fault; no or limited hydraulic drive function. Notify your authorised service centre.
TILTING A3107 A3108	Sensor fault; no or limited hydraulic drive function. Notify your authorised service centre.
AUX1 A3112 A3113	Sensor fault; no or limited hydraulic drive function. Notify your authorised service centre.
AUX2 A3117 A3118	Sensor fault; no or limited hydraulic drive function. Notify your authorised service centre.
VERTICAL MAST A3130 A3131 A3132	No hydraulic function. Turn off "vertical lift mast position". Notify your authorised service centre.
VERTICAL MAST ERROR A3135	No hydraulic function. Turn off "vertical lift mast position". Notify your authorised service centre.
SUPPLY A2242 A2257	Transmitter power supply short circuit. Truck cannot be driven. Notify your authorised service centre.
SURVEILLANCE A2801 A2802 A2808 A2809 A2810 A2815	Drive unit not functioning. Release accelerator pedal. If this error occurs sporadically, it can be tolerated. If the operational capacity is impaired, notify your authorised service centre.
SURVEILLANCE A2803 A2806	Drive direction is set to neutral. Reselect the drive direction. If this error occurs sporadically, it can be tolerated. If the operational capacity is impaired, notify your authorised service centre.

Message text/ Error code	Comment
SURVEILLANCE A2817	Truck is not ready for operation. Turn the key switch to the zero position and restart. If this error occurs sporadically, it can be tolerated. If the operational capacity is impaired, notify your authorised service centre.
DRIVE A5041	Temperature sensor fault Notify your authorised service centre.
OIL PRESSURE A5631	Engine faulty (no oil pressure) or sensor faulty. Engine is switched off for protection. Notify your authorised service centre.
COOLANT LEVEL A5611	Fan is not running. Cooling fluid level too low, check the cooling fluid level and top up the cooling fluid if necessary. If this does not resolve the problem, contact your authorised service centre.
AIR FILTER A5651	Depending on the design of the air filter, replace the filter insert or the filter cartridges. If this does not resolve the problem, contact your authorised service centre.
CONTROL UNIT A3305	CIO not functioning. Notify your authorised service centre.
EXHAUST GAS PURIFIER A5791	No regeneration and no intermediate glow. Notify your authorised service centre.
EXHAUST GAS PURIFIER A5792 A5793 A5794 A5796	Regeneration cannot be started. Notify your authorised service centre.
EXHAUST GAS PURIFIER A5795 A5797 A5798	Regeneration has been interrupted. Notify your authorised service centre.
ALTERNATOR A5811	Starter battery is not charged. Notify your authorised service centre.

General messages

NOTE

Some of the following messages are equipment-specific and may not appear on the display and operating unit of every truck. The following messages are therefore intended only as a reference.

Display messages

SERVICE BRAKE message

If the message **SERVICE BRAKE** appears on the display, notify the authorised service centre.

- Park the truck securely for checking by the authorised service centre.
- If multi-disc brakes in the drive wheel units are blocked, tow the truck.

APPLY HANDBRAKE message

DANGER

Risk of fatal injury from being run over if the truck rolls away!

Parking the truck without the parking brake applied is dangerous and is not permitted.

- The truck must not be parked on a slope.
- Only leave the truck when the parking brake has been applied.
- In emergencies, secure the truck using wedges on the side facing downhill.



NOTE

The truck is equipped with a negative spring-operated brake. Switching off the truck will block the multi-disc brakes in the drive wheel units after a few minutes. However, the truck can still roll until the drive wheel units are blocked. For this reason, the parking brake must always be applied before you leave the truck!

If you park the truck without applying the parking brake and then vacate the driver's seat, the **APPLY HANDBRAKE** message will appear in the display (variant). An optional signal tone sounds.

- Apply the parking brake.

The **APPLY HANDBRAKE** message disappears.

If the truck moves even though the parking brake is applied:

- Drive the truck onto level ground and park it safely. Secure it with wedges if necessary.
- Notify the authorised service centre.

BRAKE SENSOR message

If the BRAKE SENSOR message appears in the display, the maximum driving speed will be reduced. The brake sensor in the brake pedal must be checked.

- Notify the authorised service centre.

CODE DENIED message

If the message CODE DENIED appears on the display, the driver PIN has been entered incorrectly three times. The input is then locked for five minutes before another attempt can be made.

- Enter the driver PIN again after five minutes.

ACCELERATOR message

If the ACCELERATOR message appears on the display, the truck will remain stationary. The accelerator must be checked.

- Notify the authorised service centre.

SWITCH OFF TRUCK? message

If the message SWITCH OFF THE TRUCK? appears on the display, the switching-off of the truck is verified.

- Press the corresponding softkey on the display and operating unit to switch off the truck or cancel the operation.

PARKING BRAKE ACTIVE message

If the electric parking brake is applied, the PARKING BRAKE ACTIVE message appears on the display for 5 seconds.

- Release the parking brake to enable driving mode.

RELEASE PARKING BRAKE message

If the message RELEASE PARKING BRAKE appears on the display, driving mode cannot be enabled until the parking brake has been released by pressing the button.

Display messages

- Release the parking brake by pressing the button.

PARKING BRAKE: APPLY HANDBRAKE! message

If the message **PARKING BRAKE : APPLY HANDBRAKE !** appears on the display, the electric parking brake is faulty.

- Release the parking brake by pressing the button.

LOWER FORKS message

⚠ DANGER

There is a risk of fatal injury from a falling load or parts of the truck being lowered!

Parking the truck with the load lifted is dangerous and is not permitted under any circumstances! The increased safety provided by this function must not be misused in order to take safety risks.

- Lower the load fully before leaving the truck.

The fork is not lowered.

If the fork is above the height sensor, the key switch is turned off and the seat vacated, the **LOWER FORKS** message appears in the display (variant). An optional signal tone sounds.

- Lower the fork to the ground.

The message **LOWER FORKS** disappears.

STEERING message

If the **STEERING** message appears in the display, the truck will only move at emergency mode speed. The steering angle sensor must be checked.

- Notify the authorised service centre.

TILTING SPEED message

If the message **TILTING SPEED** appears on the display after the welcome screen, the tilting speed of the lift mast on this truck is significantly higher than on previous trucks in this family.

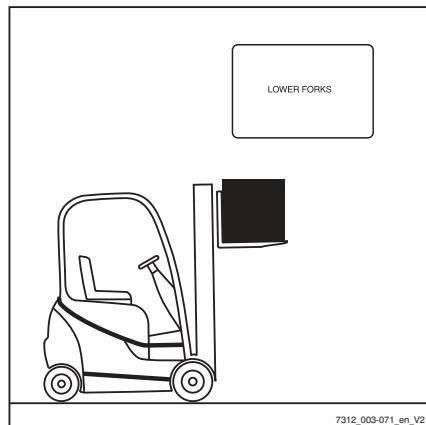

EMERGENCY SWITCH message

⚠ WARNING

No electric braking assistance is available when the emergency off switch is actuated!

Actuating the emergency off switch will disconnect the drives from the power supply.

- To brake, actuate the service brake.

The truck is equipped with an emergency off switch. When this switch is actuated, the driving functions and the functions of the working hydraulics are blocked.

The **EMERGENCY SWITCH** message appears periodically when the following criteria are met:

- The key switch is set to stage "I"
- The emergency off switch is actuated
- An operating device is actuated

? VERTICAL POSITION

If the message **? VERTICAL POSITION** appears on the display, calibration of the "vertical lift mast position" has been activated.

- Save the mast position or cancel the calibration.

REFERENCE CYCLE message

If the fork was lowered after the truck was switched off, the control electronics do not know the position of the fork when the truck is restarted. The truck will only travel at a reduced driving speed. Depending on the position of the fork, the message **REFERENCE CYCLE** (variant) may appear in the display. To align the position with the control electronics, the fork must be raised.

- Switch on the key switch.

The truck will only travel at a reduced driving speed. The message **REFERENCE CYCLE** may appear in the display.

- Raise the fork.

The message **REFERENCE CYCLE** goes out, or now appears in the display for the first time and then goes out.

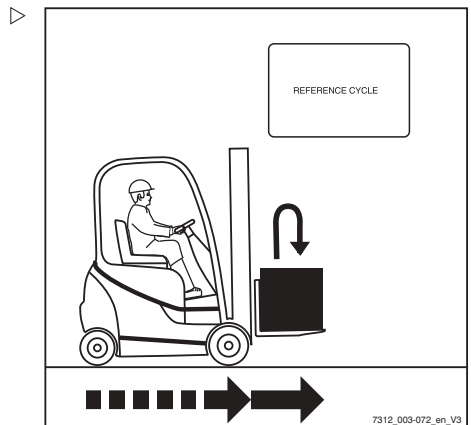

7312_003-072_en_V3

Display messages

- To drive again, lower the fork to a maximum of 300 mm above the ground.

The truck can now be driven again with no speed limitation.

SAFETY BELT message



⚠ DANGER

Risk of fatal injury in the event of falling from the truck if it tips over!

If the truck tips over, the driver is at risk of injury even if a restraint system is used. The risk of injury can be reduced by using a combination of a restraint system and a seat belt. In addition, the seat belt protects against the consequences of rear-end collisions and falling off ramps.

- We recommend that you always use the seat belt.

This device (variant) ensures that if the seat belt is not being used or is being used incorrectly, the truck will only drive slowly or (optionally) will not drive at all.

Depending on the configuration selected, the working hydraulics functions (lifting/tilting) are either available as normal, slowed down or not available at all.

The SAFETY BELT message with the restricted driving and lifting functions is triggered by the following circumstances:

- Seat belt not worn and driver's seat occupied
 - The seat belt is constantly fastened but the driver's seat is only occupied afterwards
 - The seat belt is not fastened until after the key switch has been switched on
 - The seat belt is unfastened while driving
- If the SAFETY BELT message appears, fasten the seat belt in accordance with the regulations.

The truck can again be operated without restrictions.

If the seat belt is released while driving, the truck will be limited to low driving speeds or will be braked to a halt.

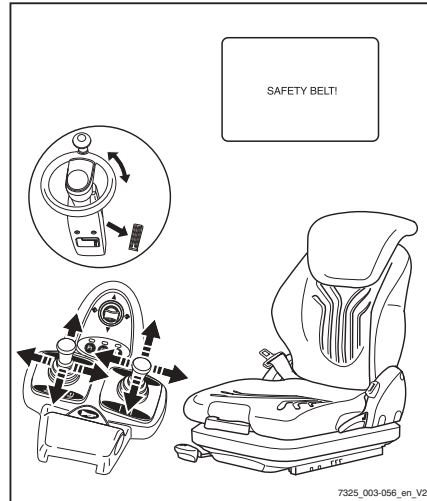

⚠ DANGER**Risk of accident!**

- The speed must be adjusted to suit the driving situation!

The increased safety provided by this function must not be misused in order to take safety risks.

ARE YOU SURE ? message

If the message ARE YOU SURE ? appears on the display, a prior prompt is verified.

- Press the corresponding softkey on the display and operating unit to continue or to cancel the operation.

SEAT SWITCH message

The truck is equipped with a seat switch.

If the SEAT SWITCH message appears, the driving functions and the working hydraulics are blocked.

The SEAT SWITCH message is triggered by the following situations:

- The seat switch is not actuated while the accelerator pedal or steering wheel is actuated
- The seat switch is not actuated while the operating device for the working hydraulics is actuated
- The shift time has been exceeded
- The operating time has been exceeded

 NOTE

The operating devices shown in the following illustrations are only examples and may differ from the equipment in your truck.

Display messages

The seat switch is not actuated while the accelerator pedal or steering wheel is actuated

The accelerator pedal or the steering wheel is actuated, even though no one is sitting in the driver's seat. The message **SEAT SWITCH** appears on the display. The truck will not move.

- Sit in the driver's seat and fasten the seat belt.

The truck can be driven again without restrictions.

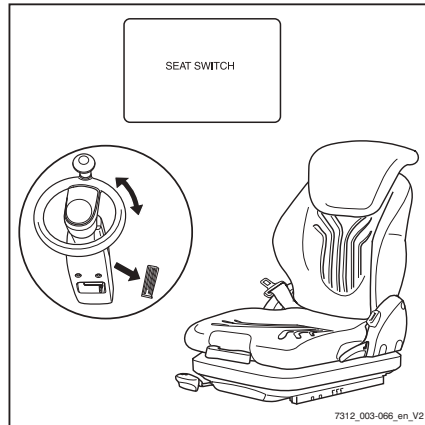

The seat switch is not actuated while the operating device for the working hydraulics is actuated

An operating device for the working hydraulics is actuated, even though no one is sitting in the driver's seat. The message **SEAT SWITCH** appears on the display. The working hydraulics functions cannot be executed.

- Sit in the driver's seat and fasten the seat belt.

The working hydraulics can be operated again.

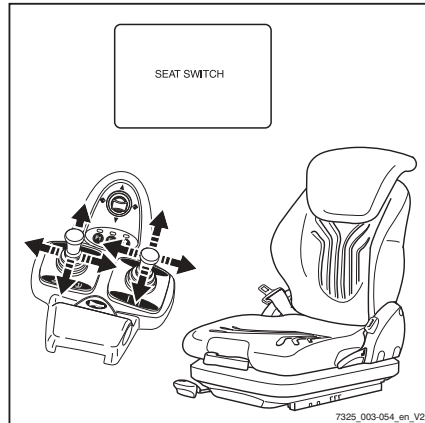

The shift time has been exceeded

i NOTE

The shift time is adjustable.

If the key switch is switched on and the driver does not leave the seat before the set shift time is exceeded, SEAT SWITCH appears on the display. This is also the case if an operating device for the working hydraulics or the accelerator pedal is actuated. Depending on the configuration, the working hydraulic functions can be executed normally, only slowly or not at all.

- Stand up briefly from the seat, sit back down again and fasten the seat belt.

The truck can again be operated without restrictions.

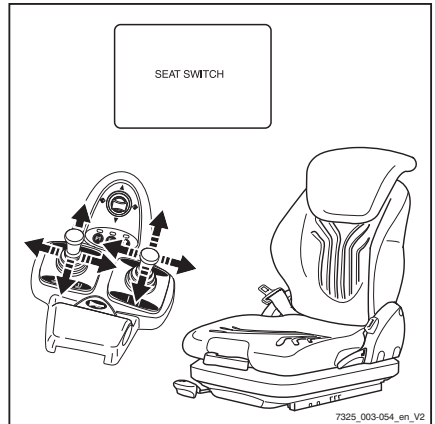

The operating time has been exceeded

i NOTE

The operating time is adjustable.

If the key switch is switched on, the parking brake is released and the driver does not leave the seat before the set operating time is exceeded, and if neither the operating devices for the working hydraulics nor the accelerator pedal are actuated during this time, SEAT SWITCH appears on the display. The truck will not move. Depending on the configuration, the working hydraulic functions can be executed normally, only slowly or not at all.

- Stand up briefly from the seat, sit back down again and fasten the seat belt.

The truck can again be operated without restrictions.

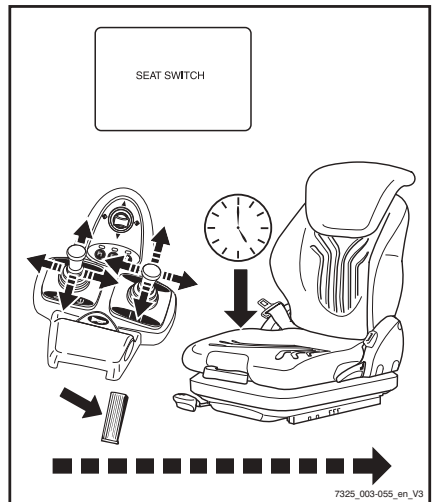

OVERHEATING message

If the message OVERHEATING appears on the display, the traction motors have overheated. The acceleration and the speed of the truck are reduced.

- Allow the truck to cool down.
- If the error persists, contact your authorised service centre.

Display messages

SURVEILLANCE message

If the SURVEILLANCE message appears in the display, there is a fault in the process monitoring.

This shuts off the drive unit.

- Switch the key switch to the "0" position and then back to the "I" position.
- Start the engine.
- Release accelerator pedal.
- Select the drive direction again.



NOTE

If this error occurs sporadically, it can be tolerated. If the operational capacity is impaired, notify your authorised service centre.

NOT VALID message

If the message NOT VALID appears on the display, an incorrect driver PIN has been entered when entering the access code.

- Once the message goes out, enter the driver PIN again.

Drive-specific messages



NOTE

Some of the following messages are equipment-specific and may not appear on the display and operating unit of every truck. The following messages are therefore intended only as a reference.

EXH.GAS PURIFIER message

If the EXH.GAS PURIFIER message appears on the display, the particle filter is full.

- Regenerate the particle filter.

i NOTE

If the EXH . GAS PURIFIER message appears during regeneration, a fault has occurred.

- *Notify the authorised service centre*

EXH.GAS PURIFIER PLEASE WAIT message

If the EXH . GAS PURIFIER PLEASE WAIT message appears on the display, the particle filter is being regenerated.

- Wait for particle filter regeneration.

EXH.GAS PURIFIER SERVICE!! message

If the message EXH . GAS PURIFIER SERVICE!!! appears on the display, the particle filter was not regenerated on time. The particle filter system must be repaired by the authorised service centre.

- To avoid damage, take the truck out of operation until it is repaired.
- Notify the authorised service centre.

CUTOUT MODE message

When automatic shut-off is activated, the message CUTOUT MODE appears on the display; see the section entitled "Automatic shut-off of the internal combustion engine (variant)".

- Sit on the driver's seat.

The message goes out and the truck is ready for operation again.

ADBLUE URGENT! message

If the AdBlue filling level drops below 2 litres, the driving speed is limited to 2 km/h.

- Maintain the quality of the AdBlue; see the section entitled "Maintenance data table".
- Top up the AdBlue.

Display messages

ADBLUE FILLING LEVEL message

If the filling level of the AdBlue tank falls sharply, the **ADBLUE FILLING LEVEL** message appears on the display and operating unit.

If an AdBlue filling level of 2 litres is reached, the driving speed is limited to 5 km/h.

- Maintain the quality of the AdBlue; see the section entitled "Maintenance data table".
- Top up the AdBlue.

ADBLUE REFILL 5l message

If the message **ADBLUE REFILL 5l** appears, max. 5 litres of AdBlue must be added.

- Maintain the quality of the AdBlue; see the section entitled "Maintenance data table".
- Top up the AdBlue.

ADBLUE QUALITY message

This truck is equipped with a sensor that measures the quality of the exhaust gas cleaned using AdBlue.

If the quality of the exhaust gas deteriorates, the **ADBLUE QUALITY** message appears on the display and operating unit.

If the exhaust gas quality deteriorates further, the driving speed is limited to 5 km/h.

- Maintain the quality of the AdBlue; see the section entitled "Maintenance data table".
- Top up the AdBlue.

ADBLUE QUALITY URGENT! message

If the quality sensor detects a deterioration in the quality of the exhaust gas cleaned with AdBlue, the message **ADBLUE QUALITY URGENT!** appears on the display and operating unit.

The driving speed is limited to 2 km/h.

- Maintain the quality of the AdBlue; see the section entitled "Maintenance data table".
- Top up the AdBlue.

ASH LOAD message

If the message **ASH LOAD** appears on the display, the particle filter has become clogged with ash. Repair must be performed by the authorised service centre.

- Notify the authorised service centre.

GLOW message

If the **GLOW** message appears in the display, the engine is being preheated.

Preheating can take up to 22 seconds. If the engine is already at operating temperature, preheating is not performed.

- Once the message goes out, start the engine.

HYBRID SYSTEM message

If the message **HYBRID SYSTEM** is shown on the display, the energy storage system has been deactivated because of an error.

The truck remains operational. However, the fuel consumption increases marginally.

- Contact the authorised service centre in order to rectify the error.

HYDRAULIC PUMP message

If the **HYDRAULIC PUMP** message appears on the display, there was an error in the hydraulic-pump volume control.

The engine can be overloaded and stall as a result of the overload. This causes the assisted steering and regenerative braking to malfunction. Further operation of the truck is therefore not permissible. The driving speed is limited to 5 km/h.

- Contact the authorised service centre in order to rectify the error.

FUEL FILTER message

The fuel filter is equipped with a level indicator that reports water aggregation in the fuel filter on the display and operating unit. If the message **FUEL FILTER** appears in the

Display messages

display, the fuel filter is saturated with water.
This water must be drained.

- Drain water from the fuel filter.

COOLANT LEVEL message

If the message **COOLANT LEVEL** appears on the display, the cooling fluid level is too low.

- Check the cooling fluid level and add cooling fluid if necessary.

CAUTION

Risk of engine damage!

If the cooling fluid level is low, this indicates a leak in the cooling system.

- Check the cooling system for leaks; see the chapter entitled "Cleaning the radiator, checking for leaks".

EMPTY message

If the message **EMPTY** flashes on the display, the gas supply is almost exhausted.

- Change the LPG cylinder or fill the LPG tank.

ALTERNATOR message

If the **ALTERNATOR** message appears in the display, this means that the alternator is no longer charging the starter battery.

This may have the following causes:

- Drive belt loose or damaged
- The electrics to or from the alternator are faulty
- The alternator is faulty

NOTE

If the fault is not rectified within a short time, the starter battery will soon run out of charge and it will no longer be possible to operate the truck.

- Notify the authorised service centre.

LPG AUTO. VALVE message

If the message **LPG AUTO. VALVE** appears on the display when the LPG engine is switched off, and the engine does not switch off until after approximately 60 seconds, there is an error.

Initially, the truck can still be operated. The error message is shown on the display and operating unit until the error has been rectified by the authorised service centre.

- Notify the authorised service centre.

AIR FILTER message

If the **AIR FILTER** message appears on the display, the filter insert or the filter cartridge must be replaced.

- Replace the filter insert or the filter cartridge.

OIL PRESSURE message

CAUTION

Risk of engine damage!

If the **OIL PRESSURE** message appears in the display, the engine's oil pressure is too low.

- Stop the engine immediately.

The message can have different causes:

- The engine has overheated
 - Insufficient oil
 - The oil is insufficiently viscous
 - Engine damage
- Check engine oil level.
 - Change the engine oil if necessary.
 - Notify the authorised service centre.

REGENERATION COMPLETED message

If the message **REGENERATION COMPLETED** appears on the display, parked regeneration is complete. The truck is ready for operation again.

Display messages

SCR-SYSTEM SERVICE message

If the message `SCR-SYSTEM SERVICE` appears on the display, there is a fault in the SCR exhaust gas treatment system.

- Notify the authorised service centre.

SCR-SYSTEM MALFUNCTION message

If the message `SCR-SYSTEM MALFUNCTION` appears on the display, there is a fault in the SCR exhaust gas treatment system.

- Notify the authorised service centre.

PARK. REG. URGENT!!! message

If the message `PARK. REG. URGENT!!!` appears on the display, parked regeneration of the particle filter is required urgently.

- Perform parked regeneration.

Until parked regeneration has been carried out, the maximum speed of the truck is reduced to 2 km/h. The lifting speed is restricted.

PARK. REG. ERROR message

If the message `PARK. REG. ERROR` appears on the display, parked regeneration was interrupted by applying the parking brake or by a malfunction in the internal combustion engine.

- Apply the parking brake.
- Restart parked regeneration.
- If the parking brake was not actuated and the message `PARK. REG. ERROR` appears anyway, notify the authorised service centre.

START PARK. REG.? message

If the message `START PARK. REG. ?` appears on the display, the truck is ready for parked regeneration.

- Perform parked regeneration.

START IC ENGINE message

If the message **START IC ENGINE** appears on the display, the internal combustion engine of the truck can be started.

- Start the engine.

Malfunctions in the electric parking brake

Before leaving the truck, the driver must make sure that the electric parking brake is applied properly.

If the controller detects a malfunction in the electric parking brake, the truck cannot be switched off.

Possible malfunctions

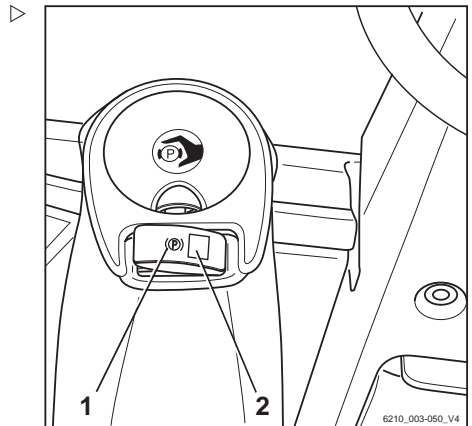

Error indication	Effect	Remedy
LED (2) in the push button (1) flashes.	Parking brake malfunction. It cannot be guaranteed that the parking brake has been applied properly. It may still be possible to actuate the parking brake by pressing the push button (1).	Park the truck safely. Notify the authorised service centre.
LED (2) in push button (1) does not light up when the brake is actuated.	It cannot be guaranteed that the parking brake has been applied properly.	Park the truck safely. Notify the authorised service centre.

Display messages

Error indication	Effect	Remedy
The actuation noise is clearly different to the normal noise or there is no noise at all.	It cannot be guaranteed that the parking brake has been applied properly.	Park the truck safely. Notify the authorised service centre.
A warning signal is issued from signal horn or another acoustic warning unit in the truck.	It cannot be guaranteed that the parking brake has been applied properly.	Park the truck safely. Notify the authorised service centre.
The truck rolls even though the parking brake has been applied.	It cannot be guaranteed that the parking brake has been applied properly.	Park the truck safely. Notify the authorised service centre.
Display and operating unit: Symbol: "Parking brake" Display: APPLY HAND-BRAKE !	LED flashes. Parking brake is not applied automatically.	Press and hold the push button (1) for five seconds and then release the push button. The parking brake will make a noise when it is applied.
Display and operating unit: Symbol: "Parking brake malfunction" Display: PARKING BRAKE Error number: X6511	The LED (2) in the push button (1) flashes. The parking brake fails to release. The drive unit is locked. The error message flashes every 30 seconds for five seconds.	Try again to release the parking brake via the push button (1). If this solution does not work, park the truck safely and notify the service centre. If the truck needs to be moved because it is in the way, release the parking brake manually. See the chapter entitled "Emergency operation of the electric parking brake". Then park the truck safely in a different location and notify the service centre.
Display and operating unit: Symbol: "Parking brake malfunction" Display: PARKING BRAKE Error number: X6512	The LED (2) in the push button (1) flashes. The parking brake is not applied. The maximum speed is limited to 5 km/h. The error message flashes every 30 seconds for five seconds.	Try again to apply the parking brake via the push button (1). If this solution does not work, park the truck safely and notify the authorised service centre. Apply the parking brake manually. See the chapter entitled "Emergency operation of the electric parking brake".
Symbol: "Service required" Display: PARKING BRAKE Error number: X6501	The LED (2) in the push button (1) flashes. Maintenance time reached. The error message flashes every 30 seconds for five seconds.	Park the truck safely. Notify the authorised service centre.

Error indication	Effect	Remedy
Display and operating unit: Symbol: "Parking brake malfunction" Display: PARKING BRAKE Error number: X6520	Control problem The drive unit remains active as long as the contactor is closed. The error message flashes every 30 seconds for five seconds.	Try again to apply the parking brake via the push button (1). If this solution does not work, park the truck safely and notify the service centre. Apply the parking brake manually if necessary. See the chapter entitled "Emergency operation of the electric parking brake".
Display and operating unit: Symbol: "Temperature" Display: PARKING BRAKE Error number: X6502	Application of the parking brake is delayed. The system switches off in the event of over-temperature. The error message flashes every 30 seconds for five seconds.	Allow the parking brake to cool down. If the warning appears again, notify the authorised service centre
Display and operating unit: Symbol: "Parking brake malfunction" Display: PARKING BRAKE Error number: X6510	Malfunction in the parking brake. The drive unit remains active as long as the contactor is closed. Creep mode is possible once the parking brake has been released. The error message flashes every 30 seconds for five seconds.	Try again to apply the parking brake via the push button (1). If this solution does not work, park the truck safely and notify the authorised service centre. Apply the parking brake manually if necessary. See the chapter entitled "Emergency operation of the electric parking brake".

Actuating a faulty electric parking brake

If the electric parking brake is faulty, the LED (2) in the push button (1) will flash and the message APPLY HANDBRAKE ! will appear on the display and operating unit. A possible cause of the malfunction is that the parking brake cannot determine whether the truck is stationary or still in motion. The brake can be then be applied via the push button (1). The following section describes how to actuate the parking brake when it is faulty:

Actuating a faulty parking brake when the truck is stationary

Apply the parking brake:

- Press and hold the push button (1) for at least five seconds and then release the push button.

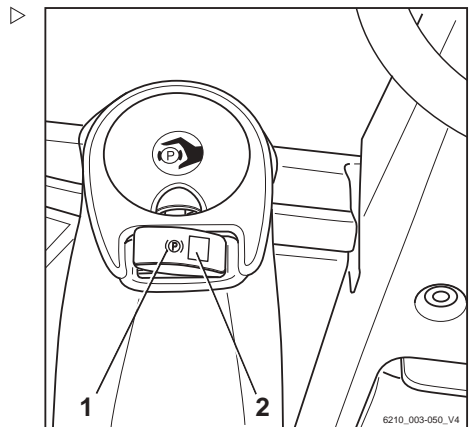

Display messages

The parking brake will make a noise when it is applied. After the push button is released, the parking brake will not make any further noise; if you hear the parking brake release again it means that the push button was pressed for less than five seconds. In this case, press the push button again to apply the parking brake again. Repeat this process up to four times if necessary.

Releasing the parking brake:

- Press the push button (1) then release the push button.

The parking brake will make a noise when it is released. If the malfunction in the parking brake persists, it will not be possible to release the parking brake.

Actuating a faulty parking brake when the truck is in motion

- Press push button.

The parking brake is applied.



NOTE

The truck will brake more sharply if the push button (1) is pressed and held for a long period or if the push button is pressed multiple times.

Switching off the truck when the electric parking brake is faulty

If the electric parking brake cannot be applied and the driver tries to switch off the truck, the truck will not switch off at first. Instead, the truck responds with the following error messages:

The red lamp (1) in the multifunction display begins to flash. ▷

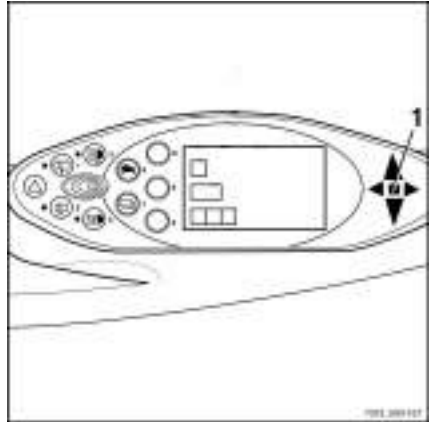

The LED (2) in the push button for the electric parking brake flashes. ▷

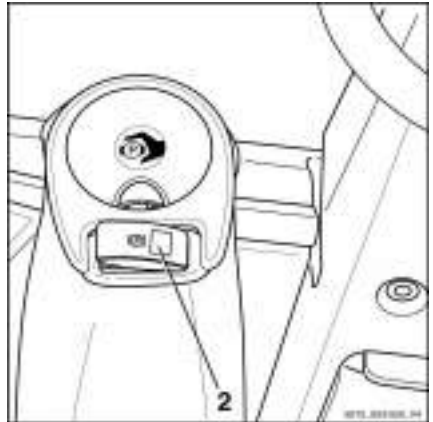

The message **PARKING BRAKE APPLY HANDBRAKE !** appears on the display and operating unit. ▷

If the driver now leaves the truck, a warning sound will be emitted and will stop only when the driver has resumed his/her seat in the truck. To switch off the truck despite the parking brake being faulty (e.g. in order to tow the truck) proceed as follows:

- Switch off the key switch again.

The message **APPLY HANDBRAKE !** will appear on the display and operating unit.

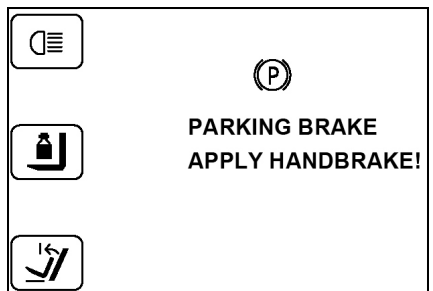

Display messages

- Press the **ESC** (3) soft key.

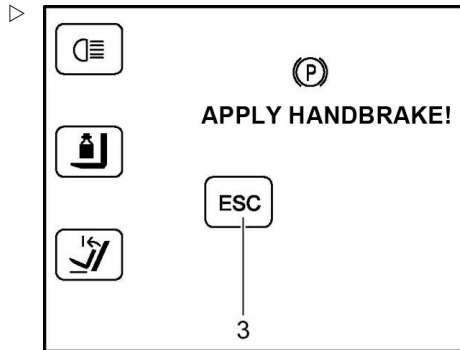

- The message **SWITCH OFF TRUCK?** will appear on the display and operating unit. To continue switching off the truck, press the soft key (4). To abort the process for switching off the truck, press the **ESC** (5) soft key.

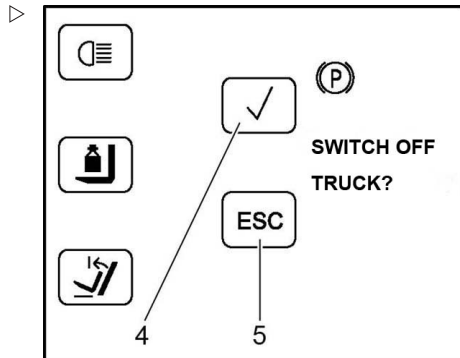

- The message **ARE YOU SURE ?** appears on the display and operating unit. To continue switching off the truck, press the soft key (6). The truck will now switch off. To abort the process for switching off the truck, press the **ESC** (7) soft key.

If switching off the truck was continued, the truck will now be switched off and the parking brake will not have been applied. The truck can now be towed. If the truck is not going to be towed, the truck must be secured with wheel chocks to prevent it from rolling away.

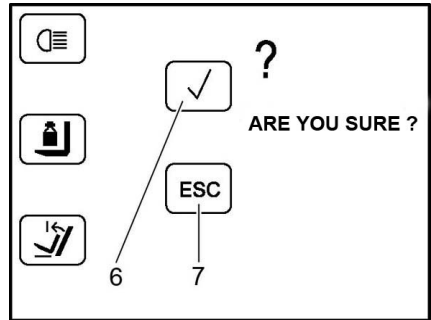

⚠ DANGER

Risk of fatal injury from the truck rolling away!

The truck is not secured against rolling away because the parking brake is not applied.

- Use wheel chocks to prevent the truck from rolling away.
- Notify the authorised service centre so that it can repair the parking brake.

Refuelling

Diesel fuel - Specifications

⚠ CAUTION

Risk of component damage if non-approved fuels are used!

Use only approved fuels with the following specifications.

If non-approved fuels are used, compliance with the specified emission values and the service life of the engine cannot be guaranteed! This truck is equipped with an engine that fulfils the requirements of Directive 97/68/EC level IIIA. The truck can also be equipped with an exhaust after-treatment system (variant).

The truck may be operated only with sulphur-free diesel fuels as defined by the following standards:

- EN 590
- ASTM D 975 Grade 2-D S15

Refuelling

- ASTM D 975 Grade 1-D S15
- or non-road fuels (light fuel oils) in line with the EN 590 standard

If these fuel types are not used, compliance with the specified emission values and the service life of the engine cannot be guaranteed.

Minimum requirements for fuels in countries in which none of the approved diesel fuels are available can be requested from the authorised service centre. The operating company is obligated to check the permissibility of the fuel used in accordance with national regulations.

The following are not permitted:

- Admixtures of petroleum, kerosene or additional fluidity additives
- Distillate fuels for marine engines
- Jet fuels
- Biodiesel fuels
- US fuels in line with the ASTM D 975 1-D S500 or ASTM D 975 2-D S500 standards
- If necessary, query with the authorised service centre.

Ensure compliance with parameters including the following limit values in accordance with EN 590:

Parameter	Unit	Value
Cetane number ¹⁾	-	Min. 51
Density at 15 C	kg/m ³	820 - 845
Sulphur content	mg/kg	Max. 10

¹⁾ The use of diesel fuels with a lower cetane number can lead to the formation of white smoke and misfiring. In winter, the use of diesel fuels with a higher cetane number is recommended.

Sulphur content in the diesel fuel

CAUTION

Insufficient lubrication can lead to engine damage!

- Use only sulphur-free diesel fuels in accordance with manufacturer specifications.

Insufficient lubricating properties in diesel fuels with a sulphur content of > 500 mg/kg can lead to serious problems due to wear, especially in common-rail injection systems. In sulphur-free diesel fuels in accordance with EN 590 and ASTM D 975, sufficient lubrication properties are ensured by using the corresponding fuel additives during refining.

Fuels with a sulphur content of $> 0.5\%$ (m/m) require a shortened change interval for the lubricating oil and must not be used in engines with a particle filter system. Fuels with a sulphur content of $> 1.0\%$ (m/m) are also not permissible due to high corrosion and a significant lifetime reduction of the engine.

Winter operation with diesel fuel

CAUTION

Adding petrol can lead to malfunctions in the fuel injection system!

- Do not add petrol.
- Do not add petroleum, kerosene or additional fluidity additives.
- If necessary, query with the authorised service centre.

During winter operation, special demands are placed on the low-temperature performance of fuels. Generally, diesel fuels that can be used at temperatures down to -44 C are available on the free market. Therefore, it is not necessary to add additives to improve the fluidity. Adding petrol can lead to the formation of vapour pockets (cavitation) in the fuel system. The formation of these vapour pockets disrupts the function of the fuel injection system and, if continued over a long period of time, can lead to component damage.

Refuelling

Non-road fuels

 NOTE

In some European countries, non-road fuels are defined with the same characteristics as light fuel oil. The permissibility of fuels is handled differently in individual countries. Light fuel oils and non-road fuels are suitable for the engine as long as compliance with the limit values of EN 590 is ensured.

- *Use only sulphur-free diesel fuels in accordance with manufacturer specifications.*
- *The operating company is obligated to check the permissibility of the fuel used in accordance with national regulations.*

Topping up the diesel fuel

⚠ CAUTION

If the diesel fuel tank has been run empty, the fuel injection system can draw in air bubbles. This can lead to malfunctions in the fuel injection system.

- Never run the diesel fuel tank empty.

The fuel reserve is shown by the fuel level indicator (1) flashing on the display screen of the display operating unit.



⚠ DANGER

There is a risk of fire when filling up with diesel fuel.

- Turn off the engine before filling up.
- When refuelling, smoking or the use of an open flame is strictly forbidden!
- Legal regulations relating to the handling of diesel fuel must be observed.
- Note safety regulations for working with diesel fuel, see ⇒ Chapter "Diesel fuel", P. 2-48.

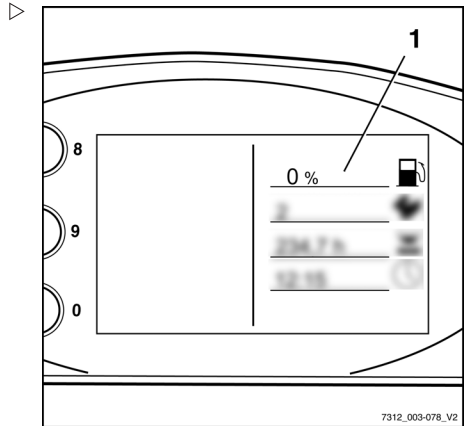

⚠ CAUTION

The truck may only be operated with diesel fuel according to DIN EN 590, otherwise there is a risk of engine damage.

- Use of fuel additives supporting soot burn-off is not permitted.
 - Starting aids (such as "Startpilot" among others) must not be used.
 - At low temperatures, winter diesel must be used, see ⇒ Chapter "Diesel fuel - Specifications", P. 4-269.
-
- Open the locking cap (2) on the fuel tank.

Refuelling

- Top up with clean diesel fuel; for the maximum filling quantity, see ⇒ Chapter "Maintenance data table", P. 5-314.

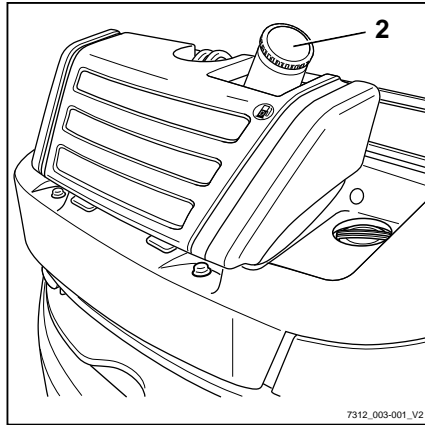

Cleaning

Cleaning the truck

- Park the truck securely.



⚠ WARNING

There is a risk of injury due to falling when climbing onto the truck!

When climbing onto the truck, you can get stuck or slip on components and fall. Higher points on the truck may only be made accessible with corresponding devices.

- Adhere strictly to the following steps.

- For climbing onto the truck, use only the steps provided for this purpose.
- For reaching inaccessible places, use devices such as stepladders or platforms.

⚠ CAUTION

If water penetrates the electrical system, there is a risk of short circuit!

- Adhere strictly to the following steps.

- Before cleaning, switch the electrical system off so that there is no voltage.
- Do not spray drive units and electrical components or their covers directly with water.

⚠ CAUTION

Failure to follow these instructions could result in damaged components!

The engine must be switched off during washing.

Water should not be used for cleaning the area around the central electrical system; instead, only clean with a dry cloth or clean compressed air.

⚠ CAUTION

Excessive water pressure or water and steam that are too hot can damage truck components.

- Adhere strictly to the following steps.
- Only use high-pressure cleaners with a maximum output power of 50 bar and at a maximum temperature of 85°C.

Cleaning

- When using high-pressure cleaners, make sure there is a distance of at least 20 cm between the nozzle and the object being cleaned.
- Do not aim the cleaning jet directly at adhesive labels or decal information.



⚠ DANGER

Risk of fire!

Deposits/accumulations of combustible materials may ignite in the vicinity of hot components (e.g. exhaust pipes).

- Adhere strictly to the following steps.

- Regularly remove all deposits/accumulations of foreign materials in the vicinity of hot components.
- Do not place combustible materials in the engine compartment.



⚠ DANGER

Flammable fluids can be ignited by hot components on the truck, causing a risk of fire!

- Adhere strictly to the following steps.

- Do not use flammable fluids for cleaning.
- Observe the manufacturer's guidelines for working with cleaning materials.

⚠ CAUTION

Abrasive cleaning materials can damage component surfaces!

Using abrasive cleaning materials that are unsuitable for plastics may dissolve plastic parts or make them brittle. The display and operating unit screen may become cloudy.

- Adhere strictly to the following steps.
- Clean plastic parts with plastic cleaning materials only.
- Observe the manufacturer's guidelines for working with cleaning materials.

Washing the truck exterior

- Clean the truck exterior with water-soluble cleaning materials and water (water jet, sponge, cloth).
- Clean all walk-in areas, the oil filling openings and their surroundings, and the lubricating nipples before lubricating.

NOTE

Please note: The more often the truck is cleaned, the more frequently it must be lubricated.

Cleaning the electrical system



CAUTION

Cleaning electrical system parts with water can damage the electrical system.

- Cleaning electrical system parts with water is forbidden!
 - Use dry cleaning materials in accordance with the manufacturer's specifications.
 - Do not remove covers etc.
-
- Clean the electrical system parts with a metal-free brush and blow the dust off with low-pressure compressed air.

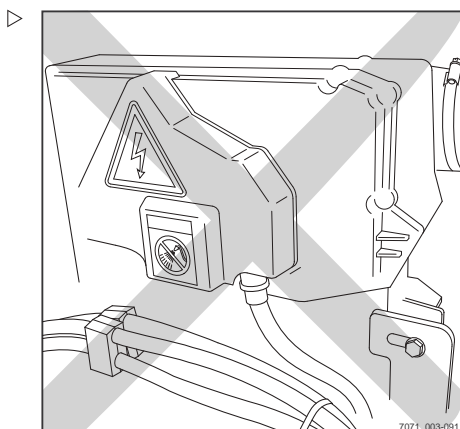

7071_003-091

Cleaning

Cleaning load chains

⚠ WARNING

Risk of accident!

Load chains are safety elements.

The use of cold/chemical cleaners or fluids that are corrosive or contain acid or chlorine can damage the chains and is forbidden!

- Observe the manufacturer's guidelines for working with cleaning materials.
-
- Place a collection vessel under the lift mast.
 - Clean with paraffin derivatives, such as benzene.
 - When using a steam jet, do not use additional cleaning agents.
 - Remove any water in the chain links using compressed air immediately after cleaning. Move the chain several times during this procedure.
 - Immediately after drying the chain, spray it with chain spray. Move the chain several times during this procedure.

For chain spray specifications, see the "Maintenance data table" chapter.

♻ ENVIRONMENT NOTE

Dispose of any fluid that has been spilled or collected in the collection vessel in an environmentally friendly manner. Follow the statutory regulations.

Cleaning the windows

Any panes of glass, e.g. cab windows (variant), must always be kept clean and free of ice. This is the only means of guaranteeing good visibility.

⚠ CAUTION

Do not damage the rear window heater (inside)!

- Take great care when cleaning the rear window and do not use any objects with sharp edges.
-
- Clean the windows using a commercially available glass cleaner.

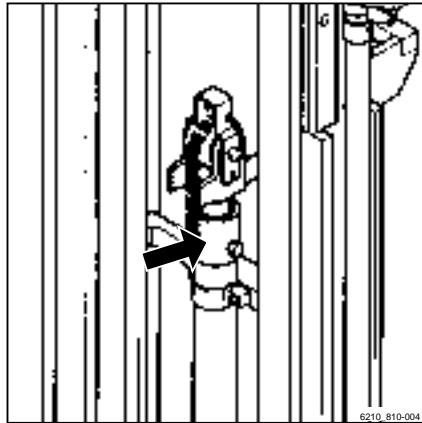

After washing

- Carefully dry the truck (e.g. with compressed air).
- Sit on the driver's seat and start up the truck in accordance with regulations.

⚠ CAUTION

Risk of short circuit!

- If any moisture has penetrated into the engine despite the precautionary measures taken, this must first be dried with compressed air.
- The truck must then be started up to prevent possible corrosion damage.

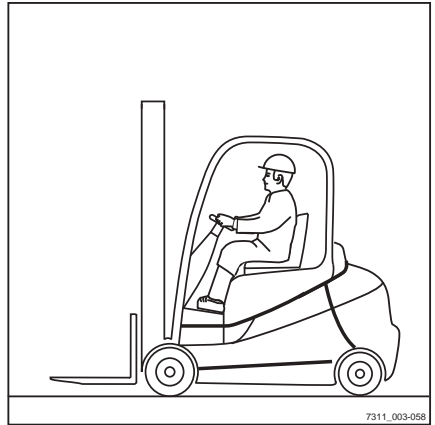

Behaviour in emergencies

Emergency shutdown

⚠ WARNING

No electric braking assistance is available when the emergency off switch is actuated!

Actuating the emergency off switch will de-energise the drive unit. The truck will not be held on a slope by the electric brake.

- Use the emergency off switch only there is a risk of fire or to carry out a functional test.
- To brake, actuate the service brake.

⚠ WARNING

There is no power steering when the emergency off switch is actuated!

The truck is equipped with a hydraulic power steering system. When the emergency off switch is actuated, the hydraulic system is completely shut down. Steering forces are increased by the remaining emergency steering function.

- Use the emergency off switch only there is a risk of fire or to carry out a functional test.
- Steer with a higher level of force.

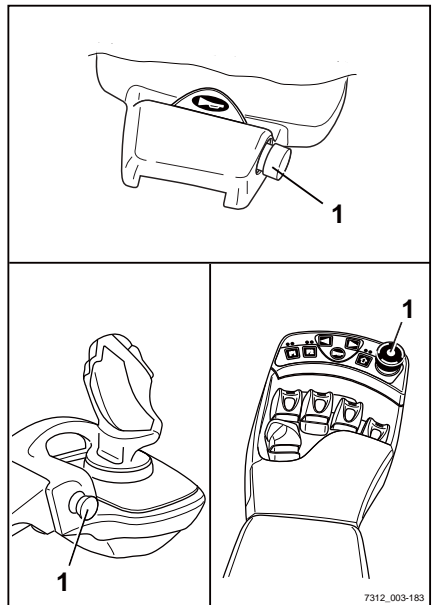

The emergency off switch (1) is used to cancel particle filter regeneration (variant) when a fire risk is present. The emergency off switch may also be used to carry out a functional test.

Behaviour in emergencies



NOTE

Only trucks with a particle filter system (variant) or a joystick 4Plus (variant) have an emergency off switch.

Actuating the emergency off switch in drive mode switches off the electric brake, the hydraulic system and the drive unit. This has the following effect:

- No reduction in truck speed when the accelerator pedal is released, according to the drive program selected. The truck will coast
- The electric brake does not function during the first part of brake pedal travel. To brake the truck using the mechanical brake, the brake pedal must be pushed down further
- The truck can only be held on a slope using the mechanical brake, not the electric brake
- No power steering effect. Steering forces are increased by the remaining emergency steering function.
- No hydraulic functions are available

Use the emergency off switch if there is a risk of fire or to carry out a functional test

- Press the emergency off switch (1).

The truck will roll to a stop in drive mode.

- Brake the truck to a standstill by actuating the brake pedal.

⚠ DANGER

There is a risk of fire!

If particle filter regeneration was interrupted because of a fire risk, take the truck out of operation until the defect is remedied.

- Notify your authorised service centre.

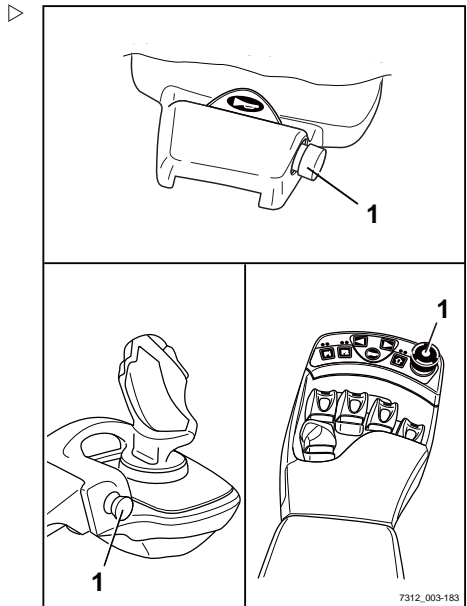

Procedure if truck tips over

⚠ DANGER

If the truck tips over, the driver could fall out and slide under the truck with potentially fatal consequences. There is a risk to life.

Failure to comply with the limits specified in these operating instructions, e.g. driving on unacceptably steep gradients or failing to adjust speed when cornering, can cause the truck to tip over. If the truck starts to tip over, do not leave the truck under any circumstances. This increases the danger of being hit by the truck.

- Do not release your seat belt.
- Never jump off the truck.
- You must adhere to the rules of behaviour if the truck tips over.

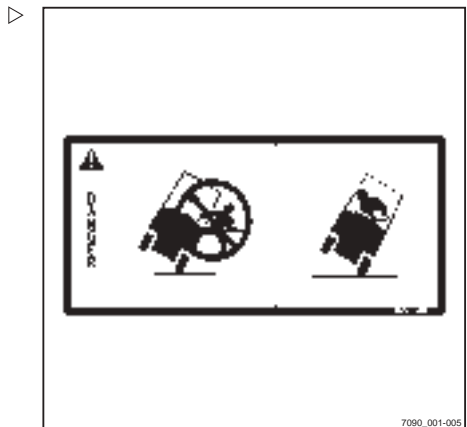

Rules of behaviour if truck tips over:

- Hold onto the steering wheel with your hands.

Behaviour in emergencies

- Brace your feet in the footwell.
- Bend your upper body over the steering wheel.
- Bend your body against the direction of the fall.

Emergency hammer

The emergency hammer is used to rescue the driver if he is shut inside the cab in a hazardous situation, for example if the truck has toppled over and the cab door cannot be opened.

Single-pane safety glass can be struck relatively safely using the emergency hammer in order for the driver to escape or be rescued from the danger area.

Using the emergency hammer

WARNING

When glass is smashed there is a risk of injury caused by glass splinters!

When the cab glass is smashed, splinters of glass can shoot into the face and cause damage to skin and eyes through cuts. When a pane of glass is smashed, the face should be turned away and covered with the crook of the free arm.

- Protect the face when smashing a pane of glass.
-
- Pull the emergency hammer out of its support mounting at the handle.
 - Using one of the two metal tips on the head of the emergency hammer, hit the pane of glass with force until it breaks.

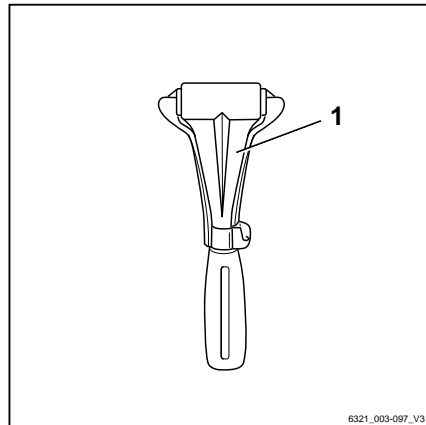

Emergency lowering

If the hydraulic control system fails whilst a load is raised, emergency lowering can be performed. An emergency lowering screw for this purpose is located on the valve block.

**⚠ DANGER**

There is a risk of fatal injury from falling loads or parts of the truck being lowered.

- Do not walk beneath the raised load.
- Adhere to the following steps.

⚠ WARNING

The load is lowered!

The lowering speed is regulated by unscrewing the emergency lowering screw.

- Note the following list.

Remember the following:

- Tightening torque:
max. 2.5 Nm
- When unscrewed a little:
The load lowers slowly
- When unscrewed a lot:
The load lowers quickly

 NOTE

The valve block is located under the bottom plate. A hexagon socket wrench (1) is mounted on the valve block support. The hexagon socket wrench must remain in the truck at all times.

- Remove the bottom plate

Behaviour in emergencies

- Take the hexagon socket wrench (1) out of the support mounting. ▷
- Using the hexagon socket wrench, turn the emergency lowering screw (2) on the valve block a maximum of 1.5 revolutions to loosen it.
- Screw the emergency lowering screw back in after the load is lowered.
- Return the hexagon socket wrench to the support mounting.
- Install the bottom plate.

⚠ DANGER

If the truck is operated with the hydraulic controller blocked, there is an increased risk of accidents!

- After the emergency lowering procedure, have the malfunction rectified.
- Notify the authorised service centre.

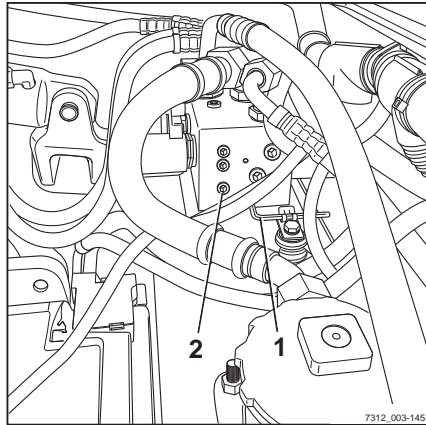

Emergency operation of the electric parking brake ▷

⚠ WARNING

The truck can roll away when the parking brake is released!

Emergency operation of the parking brake can be initiated only when the fork is lowered and the truck is switched off.

In emergency operation or during transport without a battery, the electric parking brake can be operated manually via the hand wheel.

- Lower the forks to the ground.
- Switch off the key switch.
- Lift cover (3) and move it to the side.

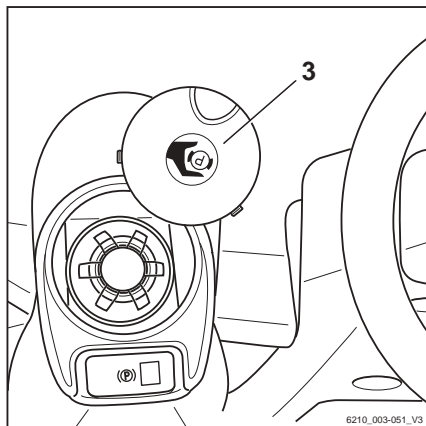

- Remove hand wheel (4) and place upside down on the tappet. ▷

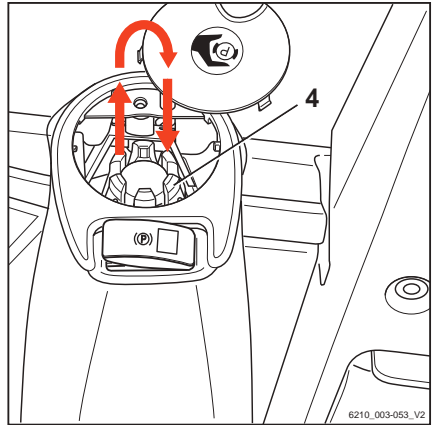

- Place the hand wheel with the tappet lugs (5) on the tappet (6) and press down against the spring force. ▷

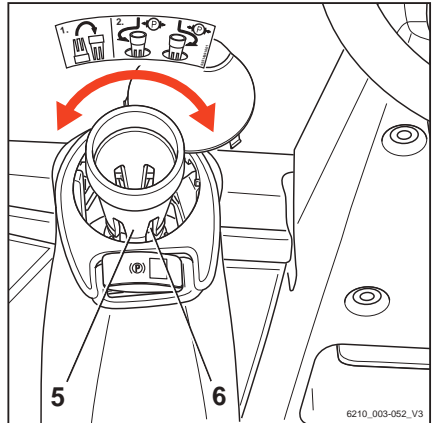

NOTE

Do not rotate the hand wheel to the stop, because this will trigger the relubrication device.

- To apply the parking brake rotate the hand wheel clockwise until the force needed increases markedly and the truck is held securely. The effort required is not great.
- To release the parking brake rotate the hand wheel anticlockwise a maximum of 5 revolutions until the hand wheel can be turned easily.

After manual operation, the hand wheel is to be returned to its latch position and the cover to its normal position.

Disconnecting the battery

The negative battery terminal is fitted with a quickly removable battery-terminal clip so that the battery can be quickly disconnected in the event of a dangerous situation (e.g. a burning cable or electrical malfunction).

- Open the bonnet; see → Chapter "Opening the bonnet", P. 5-317.

Behaviour in emergencies

- Remove the bottom plate; see → Chapter "Installing and removing the bottom plate", P. 5-318.
- Disconnect the negative terminal and put the battery-terminal clip to one side. ▷
- Disconnect the positive terminal and put the battery-terminal clip to one side.
- Close the bonnet; see→ Chapter "Closing the bonnet", P. 5-317.

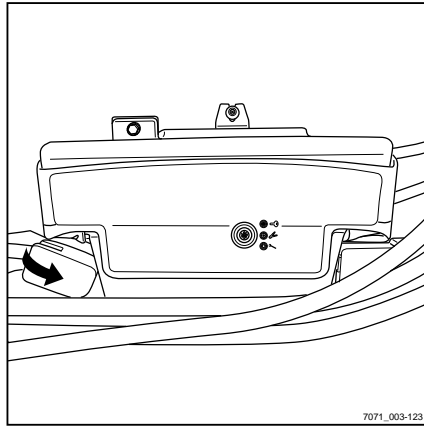

Jump starting

**⚠ DANGER****Risk of explosion due to spark discharge!**

If the electrical system on the truck is switched on, or a live cable touches a metal part of the truck, this can cause a spark discharge. Any escaping gas may explode as a result.

- If the truck has not been used for a long period of time and before starting work, ensure that the closed room is well ventilated before operating the truck.
- The metal parts of the truck must not touch the connecting terminals.

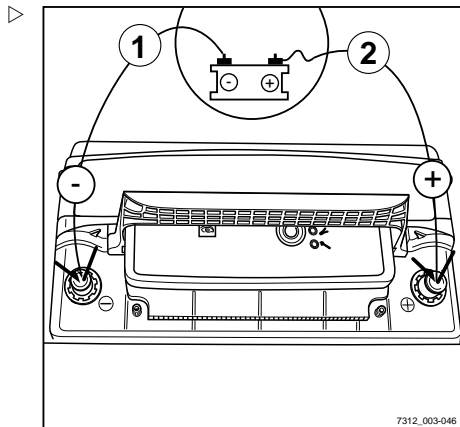
**i NOTE**

A 12 V power source (e.g. second truck of the same type) must be available.

⚠ WARNING

Risk of short circuit if the jump leads are connected or disconnected in the incorrect order!

If the batteries' negative terminals are connected to the negative cable, both bodies are also conductively connected to one another. If the positive cable touches one of the two bodies as further cables are connected, a short circuit can occur.

- Ensure that the correct order is followed when connecting and disconnecting the jump leads.
-
- Remove the bottom plate; see ⇒ Chapter "Installing and removing the bottom plate", P. 5-318.
 - Remove the terminal protective caps from the battery terminals.
 - Allow the engine of the current-giving truck to run.

Connecting the jump leads:

- Connect the positive cable (2) to the positive terminal on the discharged battery.
- Connect the positive cable to the positive terminal on the current-giving battery.
- Connect the negative cable (1) to the negative terminal on the current-giving battery.
- Connect the negative cable to negative terminal on the discharged battery.

⚠ CAUTION

The vibrations produced when the engine is started can cause the jump leads to slip off. There is a risk of short circuit!

- Before starting the engine, check that the jump leads are connected securely.
-
- Start the engine, see ⇒ Chapter "Starting the engine", P. 4-98.

Disconnecting the jump leads:

- Disconnect the negative cable (1) from the negative terminal on the discharged battery.
- Disconnect the negative cable from the negative terminal on the current-giving battery.
- Disconnect the positive cable (2) from the positive terminal on the discharged battery.

Behaviour in emergencies

- Disconnect the positive cable from the positive terminal on the current-giving battery.

NOTE

Leave the engine to run because the battery is not yet sufficiently charged.

- Refit the terminal protective caps.
- Reattach the bottom plate.

Towing

DANGER

The brake system on the towing vehicle may fail. There is a risk of accident!

If the towing vehicle's brake system is not of the correct size, the vehicle cannot be braked securely or the brakes may fail. The towing vehicle must be able to absorb the pulling and braking forces from the unbraked towed load (total actual weight of the truck).

- Check the pulling and braking force of the towing vehicle.

DANGER

The truck could drive into the towing vehicle when the towing vehicle brakes. There is a risk of accident!

If a rigid connection has not been used during towing for the power transmission in two directions, the truck may drive into the towing vehicle when the towing vehicle brakes. For safety reasons, only a tested tow bar may be used.

- Use a tested tow bar.
- Set down load and lower fork arms close to the ground.

CAUTION

If the drive of the truck between the drive motor and the drive axle is not interrupted, the drive may be damaged.

- Place the drive direction switch in the neutral position.
- Apply the parking brake.
- Switch off the engine.

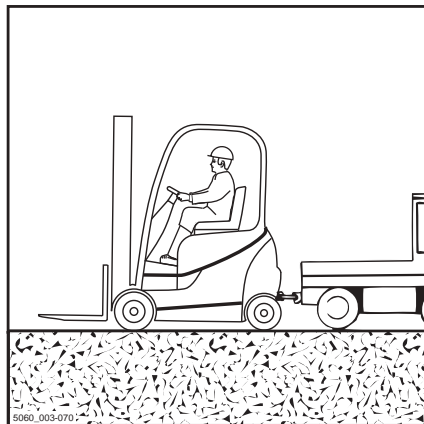

⚠ DANGER

People can be crushed between the truck and towing vehicle during manoeuvring. There is a risk to life!

The manoeuvring of the towing vehicle and the attachment of the tow bar may only be carried out using a second person as a guide. This ensures that the driver of the towing vehicle and the mechanic attaching the tow bar are aware of possible risks.

- Only manoeuvre with a guide.
-
- Secure the tow bar to the tow coupling of the towing vehicle and the truck.

⚠ CAUTION

Steering is tight! There is no power steering if the hydraulics fail!

- The selected towing speed must allow braking and control of the truck and towing vehicle at all times.

⚠ CAUTION

If the truck is not steered while it is being towed, it may veer out uncontrollably!

- The truck to be towed must also be steered by a driver.
 - The driver of the truck to be towed must sit in the driver's seat and fasten the seat belt before towing.
 - Where possible, activate the restraint systems provided.
-
- Release the parking brake.
 - Tow the truck.
 - After towing, secure the truck from rolling away (e.g. by applying the parking brake or using chocks).
 - Remove the tow bar.

Transporting the truck

Transporting the truck

Transport

When driving the truck onto a means of transport, note the following:

- The load/lifting capacity of the means of transport, ramps and loading bridges must be greater than the loading weight of the truck.
- Determine the actual total weight of the truck.
- Read the nameplate on the truck and attachment (if fitted) in order to determine and add up the following weights:

	Tare weight (truck)
+	Ballast weight (truck)
+	Net weight (attachment)
+	100 kg (allowance for driver)
=	Actual total weight

- Maintain a safe distance from edges, loading bridges, ramps, working platforms etc.
- Steering movements can cause the tail end to veer off the loading bridge towards the edge. This may cause the truck to crash.
- Park the truck securely; see ⇒ Chapter "Parking the truck securely and switching it off", P. 4-141.

**NOTE**

If the electric parking brake cannot be released electrically, it must be applied manually, see ⇒ Chapter "Emergency operation of the electric parking brake", P. 4-284.

Setting chocks

- Secure both the front and rear wheels with two chocks apiece to prevent the truck from sliding or rolling away.

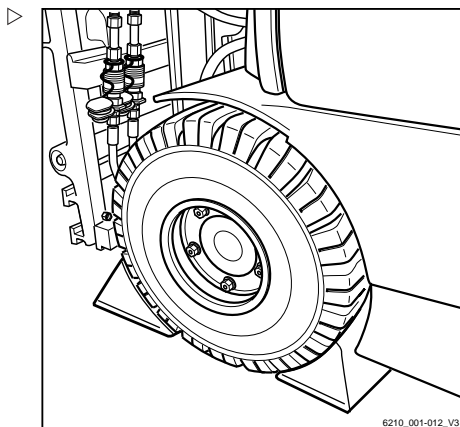

Lashing

- Attach lashing straps (1) to both sides of the truck and lash the truck to the rear.

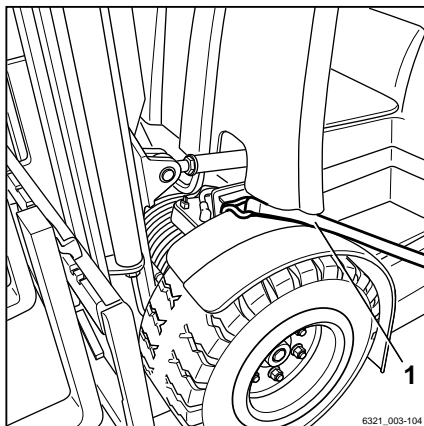

Transporting the truck

- Attach lashing straps (1) to the towing pin (2) or loop around the towing pin and lash the truck to either side.

⚠ CAUTION

Abrasive lashing straps can rub against the surface of the truck and cause damage.

- Position slip-resistant pads beneath the lifting points (e.g. rubber mats or foam).

⚠ DANGER

The load may slip if the lashing straps slide off

The truck must be lashed securely so that it cannot move during transportation.

- Make sure that the lashing straps are tightened securely and that the pads cannot slip off.

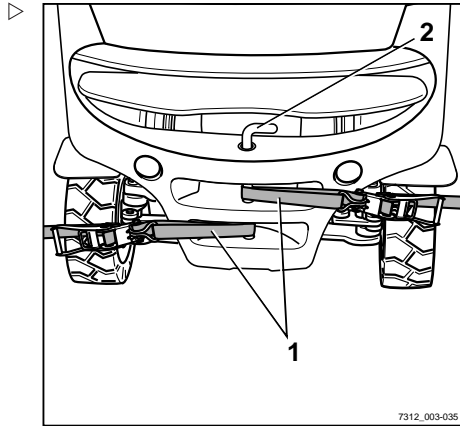

Crane loading

Crane loading is only intended for transporting the complete truck, including the lift mast, for its initial commissioning. For application conditions that require frequent loading or that are not presented here, please contact the manufacturer with regard to special equipment variants.

Only those persons with sufficient experience of suitable harnesses and hoists may load trucks.

Determining the loading weight

- Park the truck securely; see ⇒ Chapter "Parking the truck securely and switching it off", P. 4-141.
- Determine the unit weights by reading them off the truck nameplate and, if necessary, the attachment (variant) nameplate.
- Add the determined unit weights to obtain the loading weight of the truck:

Tare weight (1)

+ Ballast weight (variant) (2)

+ Attachment net weight (variant)

= Loading weight

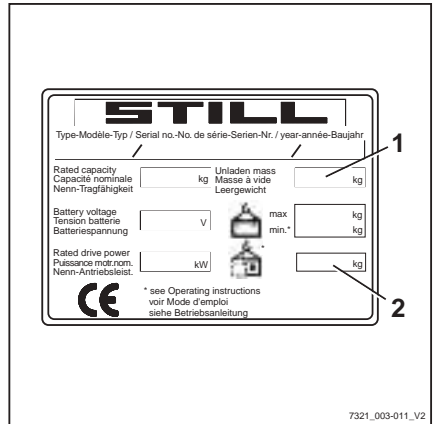

Hooking on the lifting straps

CAUTION

Harnesses may damage the truck's paintwork!
 Harnesses can damage paintwork by chafing and pressing on the surface of the truck. Hard or sharp-edged harnesses, such as wires or chains, can quickly damage the surface.

- Use textile harnesses, e.g. lifting straps, with edge protectors or similar protective devices if necessary.

DANGER

There is a risk of being hit if the hoists and harnesses fail and cause the truck to fall. Danger to life!

- Only use hoists and harnesses with adequate load capacity for the determined loading weight.
- Only use the truck's designated lifting points.
- Make sure that harnesses such as hooks, shackles, belts etc. are only used in the indicated load direction.
- The harnesses must not be damaged by truck parts.

- Loop the lifting straps around the main traverse (3) on the outer mast of the lift mast.

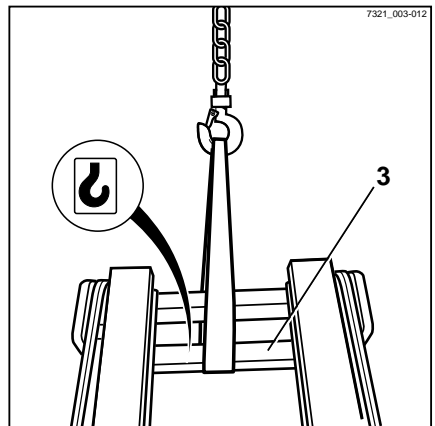

Transporting the truck

i NOTE

The lifting points are indicated by a hook symbol.

- Loop the lifting straps around the counter-weight (4), as indicated. ▷
- Determine the truck's centre of gravity; see ⇒ Chapter "Dimensions", P. 6-348.

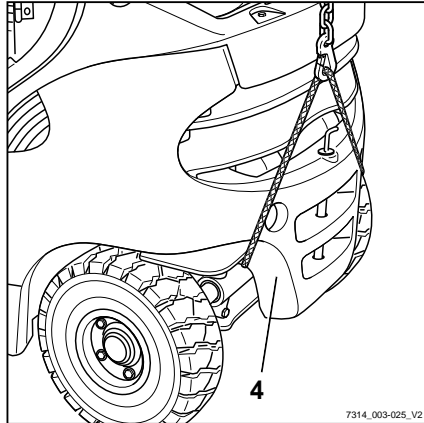

- Adjust the length of the harnesses so that the lifting eye (6) is directly above the truck's centre of gravity. ▷

This ensures that the truck hangs level when lifted.

- Connect the lifting straps to the lifting eye and insert the safety device (5).

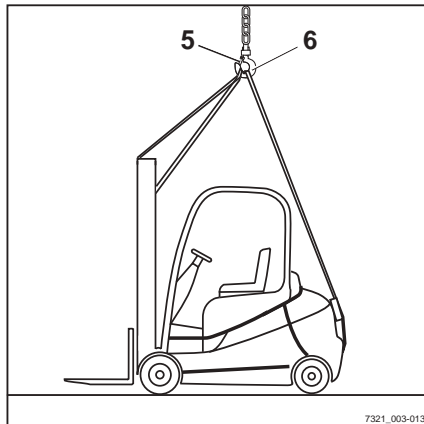
**⚠ CAUTION**

Incorrectly fitted harnesses may damage attachment parts!

Pressure from the harnesses can damage or destroy attachment parts when the truck is lifted. Take particular care to ensure that the fuel system is not damaged or destroyed. In some circumstances, diesel fuel may leak from the damaged fuel system.

- Secure harnesses so that they are not touching any attachment parts.
 - Use a bridge piece if necessary.
-
- Check that harnesses cannot collide with attachment parts.

Always use a bridge piece to prevent collisions with attachment parts that protrude beyond the contours of the cab, e.g. air conditioning, rotating beacon etc. ▷

⚠ CAUTION

Incorrectly fitted harnesses may damage attachment parts!

Harnesses may be positioned near attachment parts even if a bridge piece is used. Pressure from the harnesses can damage or destroy attachment parts when the truck is lifted.

- Secure harnesses so that they are not touching any attachment parts.

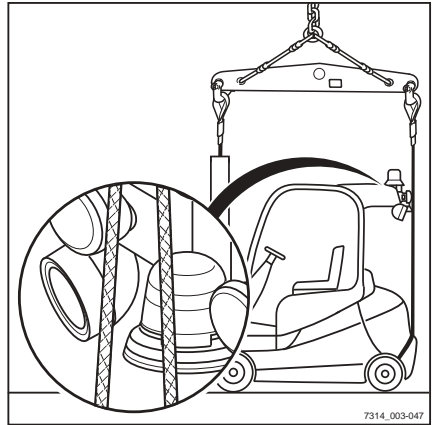

7314_003-047

Loading the truck



⚠ DANGER

If the raised truck swings in an uncontrolled fashion, it may crush people. There is a risk to life!

- Never walk or stand underneath suspended loads.
- Do not allow the truck to bump into anything whilst it is being lifted, or allow it to move in an uncontrolled way.
- If necessary, hold the truck using guide ropes.

- Carefully lift the truck and set it down at the intended location.

Shutdown

Shutting down and storing the truck

⚠ CAUTION

Component damage due to incorrect storage!

If the truck is stored or shut down incorrectly for more than two months, it may suffer corrosion damage. If the truck is parked in an ambient temperature of less than -10°C for an extended period, the battery will cool down. The electrolyte may freeze and damage the battery.

- Carry out the following measures before shutdown.

Shutdown

CAUTION

Danger of tyre deformation by continuously loading on one side!

Have the truck raised and jacked up by the authorised service centre so that all the wheels are clear of the ground. This prevents permanent deformation of the tyres.

CAUTION

Danger of damage from corrosion due to condensation on the truck!

Many plastic films and synthetic materials are watertight. Condensation water on the truck cannot escape through these covers.

- Do not use plastic film as this encourages the formation of condensation water.
-

NOTE

Store only fully charged batteries.

Measures before shutdown

- Store the truck in a dry, clean, frost-free and well ventilated environment.
- Clean the truck thoroughly; see the chapter entitled "Cleaning".
- Lift fork carriage to full extent several times.
- Tilt the lift mast forwards and backwards several times and, if fitted, move attachment repeatedly.
- To relieve the strain on the load chains, lower the fork onto a suitable supporting surface, e.g. a pallet.
- Check the hydraulic oil level and top up if required.
- Apply oil or grease thinly to all uninsulated moving parts.
- Lubricate the forklift truck.
- Lubricate the joints and controls.
- Fill the fuel tank.
- Remove the battery and store in a warm and dry location.

- Regularly check the charge state of the battery and recharge if necessary.
- Apply a suitable contact spray to all exposed electrical contacts.
- Preserve the engine as specified by the manufacturer.
- Cover the truck with vapour permeable materials, such as cotton, in order to protect against dust.
- If the truck is to be shut down for even longer periods, contact your authorised service centre to find out about additional measures.

Returning to service after storage

If the truck has been in storage for longer than six months, it must be carefully checked before being put back into service. As in the annual inspection, this check should also include all safety items for the truck.

- Clean the truck thoroughly.
- Oil joints and controls.
- Check battery condition and acid density; recharge if necessary.
- Restore engine to normal condition according to regulations of engine manufacturer.
- Check hydraulic oil for condensation water; change if necessary.
- Perform maintenance work as before initial start-up.
- Put the truck into operation.

During start-up, check in particular:

- Drive, control, steering
- Brakes (service brake, parking brake)
- Lifting system (load-carrying equipment, load chains, mounting)

5

Maintenance

Safety instructions for maintenance

Safety instructions for maintenance

General information

DANGER

Risk of fatal poisoning!

It is dangerous to leave the engine running in enclosed spaces. The engine consumes oxygen and emits carbon dioxide, carbon monoxide and other poisonous gases. There is a risk of fatal poisoning!

- Only operate the truck in areas that are well ventilated.

To prevent accidents during maintenance work and repair work, all necessary safety measures must be taken, e.g.:

- Apply the parking brake.
- Switch off the key switch and remove the key.
- Ensure that the truck cannot move unintentionally or start up inadvertently.
- If required, have the truck jacked up by the authorised service centre.
- Have the raised fork carriage or the extended lift mast secured against accidental lowering by the authorised service centre.
- Insert an appropriately sized wooden beam as an abutment between the lift mast and the cab, and secure the lift mast to prevent it tilting backwards unintentionally.
- Observe the maximum lift height of the lift mast, and compare the dimensions from the technical data with the dimensions of the hall into which the truck is to be driven. These steps are taken to prevent a collision with the ceiling of the hall and to avoid any damage caused as a result.

Working on the hydraulic equipment

The hydraulic system must be depressurised prior to all work on the system.

Working on the electrical equipment

Work may only be performed on the electrical equipment of the truck when it is in a voltage-free state. Function checks, inspections and adjustments on energised parts must only be performed by trained and authorised persons, taking the necessary precautions into account. Rings, metal bracelets etc. must be removed before working on electric components.

To prevent damage to electronic systems with electronic components, such as an electronic driving regulator or lift control, these components must be removed from the truck prior to the start of electric welding.

Work on the electrical system (e.g. connecting a radio, additional headlights etc.) is only permitted with approval from the authorised service centre.

Working on the ignition system

To prevent personal injury and/or destruction of the ignition system, please observe the following:

- Only connect and disconnect ignition system lines, including high-voltage lines and measuring device lines, with the ignition switched off.
- If the engine is to be operated at starting speed but not actually started (e.g. for a compression pressure test), disconnect the connection assembly from the ignition coil.
- Use of a quick charger to jump start the engine is only permitted for a period of up to 1 minute at max. 16.5 volts.
- The engine may only be washed when the ignition is switched off.
- When performing electric or point welding, completely disconnect the battery.
- Trucks that have a fault in the ignition system, or a suspected fault, may only be towed if the plug is disconnected from the ignition coil.

Safety instructions for maintenance

Safety devices

After maintenance and repair work, all safety devices must be reinstalled and tested for operational reliability.

Set values

The device-dependent set values must be observed when making repairs and when changing hydraulic and electrical components. These are listed in the appropriate sections.

Lifting and jacking up

DANGER

There is a risk to life if the truck tips over!

If not raised and jacked up properly, the truck may tip over and fall off. Only the hoists specified in the workshop manual for this truck are allowed and are tested for the necessary safety and load capacity.

- Only have the truck raised and jacked up by the authorised service centre.
- Only jack the truck up at the points specified in the workshop manual.

The truck must be raised and jacked up for various types of maintenance work. The authorised service centre must be informed that this is to take place. Safe handling of the truck and the corresponding hoists is described in the truck's workshop manual.

Working at the front of the truck

DANGER

Risk of accident!

If the lift mast or fork carriage is raised, no work may be performed on the lift mast or at the front of the truck unless the following safety measures are observed.

- When securing, only use chains with sufficient load-bearing capacity.
- Contact the authorised service centre.

⚠ CAUTION

- Possibility of damage to the ceiling!
- Note the maximum lift height of the lift mast.

Securing the lift mast against tilting backwards

A hardwood beam with a cross-section of 120 x 120 mm is required. The length of the hardwood beam must approximately correspond to the width of the fork carriage (b3). To avoid impact injuries, the hardwood beam must not protrude beyond the outer contour of the truck. A maximum length matching the total width (b1) of the truck is recommended.

- Obtain the dimensions (b1) and (b3) from the corresponding VDI datasheet.
- Clamp the hardwood beam (1) between the driver protection structure (2) and the lift mast (3).

Removing the lift mast**⚠ DANGER****Risk of accident!**

This work must only be performed by an authorised service technician.

- Arrange for an authorised service technician to remove the lift mast.

Securing the lift mast against falling off**⚠ DANGER****Risk of accident!**

This work must only be performed by an authorised service technician.

- Arrange for an authorised service technician to secure the lift mast.

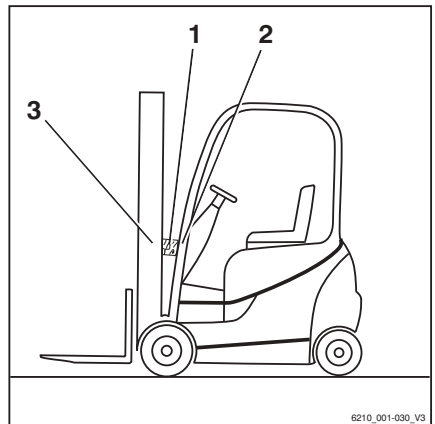

General maintenance information

General maintenance information

Personnel qualifications

Only qualified and authorised personnel are allowed to perform maintenance work. The annual testing must be carried out by a qualified person. The examination and assessment of the qualified person must be unaffected by operational and economic conditions and must be conducted solely from a safety perspective. They must have sufficient knowledge and experience to be able to assess the condition of a forklift truck and the effectiveness of the protective equipment in accordance with technical conventions and the principles for testing forklift trucks.

Maintenance work without special qualifications

Simple maintenance work, e.g. checking the hydraulic oil level, may be carried out by untrained personnel. A qualification, like that of a specialist, is not required to carry out this work. The required operations are described in sufficient detail in the corresponding places in these operating instructions.

Information for carrying out maintenance

This section contains all information required to determine when the truck needs maintenance. Carry out maintenance work within the time limits according to the hour meter and using the following maintenance check lists. This is the only way to ensure that the truck remains ready for operation and provides optimal performance and service life. It is also a precondition for any warranty claims.

Maintenance timeframe

- Carry out maintenance work on the truck in accordance with the "Service in" display (1).
- The maintenance check lists indicate the maintenance work that is due.

The intervals are defined for standard use. Shorter maintenance intervals can be defined in consultation with the operating company, depending on the application conditions of the truck.

The following factors may necessitate shorter maintenance intervals:

- Contaminated, poor quality roads
- Dusty or salty air
- High levels of air humidity
- Extremely high or low ambient temperatures, or extreme changes in temperature
- Multi-shift operation with a high duty cycle
- Specific national regulations for the truck or individual components

⚠ CAUTION

Risk of component damage!

Any deviating technical information in these operating instructions takes precedence over the information in the original engine operating instructions.

- If you have any questions, please contact your authorised service centre.

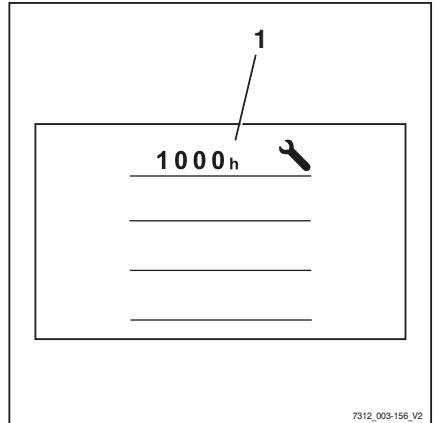

Maintenance - 1000 hours/annually

At operating hours							Carried out	
1000	2000	4000	5000	7000			✓	*
8000	10000	11000	13000	14000				
Chassis, bodywork and fittings								
Check chassis for cracks								
Check overhead guard/cab and panes of glass for damage								
Check controls, switches and joints for damage, and apply grease and oil								
Check driver's seat for correct function and for damage								
Check driver restraint system for correct function and for damage, and clean								
Variant: Check the dual pedal variant for damage and correct function, and lubricate								
Tyres and wheels								
Check tyres for wear and check the air pressure								
Check wheels for damage and check the tightening torques								
Power unit								
Drive axle: Check the screw joints, check for leaks and clean the cooling fins								
Gearbox oil: Check oil level								
Internal combustion engine								
Check the condition of the internal combustion engine (visual inspection)								
Change engine oil and oil filter								
Check toothed belt, spur gears and V-belt								
LPG: Replace the spark plugs								
Check the air filter and replace if necessary								
Check the cooling system for leaks and correct function								
Check coolant and top up if necessary								
Check the exhaust system								
Variant: Service the particle filter								
Fuel system								
Check the fuel system for leaks and correct function								
Change the fuel filter								
LPG system								
Check the LPG system for damage								

General maintenance information

At operating hours								Carried out			
1000	2000	4000	5000	7000	8000	10000	11000	13000	14000	✓	*
Check the solenoid shut-off valve, and if necessary check the high-pressure relief valve (1.7 bar)											
Check the gas cylinder valve for cleanliness and correct function, check the over-pressure safety device (30 bar)											
Change the LPG filter											
Change the evaporator (C Series) or overhaul the evaporator (MD/Cobra) Replace the sticker											
Check the screw joints for secure attachment and perform a leak test											
Check the CO content in the exhaust gas											
Check that the duration of engine run-on before the engine stops is acceptable											
Steering											
Check the steering system for correct function and for leaks											
Check that the steering wheel is securely attached and check the turning handle for damage											
Steering axle: Check that the steering axle is securely attached, check for leaks and apply grease											
Check the steering stop											
Brake											
Check the condition of all mechanical brake parts and check for correct function											
Perform brake test											
Electrical system											
Check all power cable connections											
Check the switches, transmitters and sensors for correct function											
Check the lighting and indicator lights											
Starter battery											
Measure the cold-start current; recharge or replace the battery if necessary.											
Hydraulics											
Check the condition of the hydraulic system, and check for correct function and leaks											
Check the oil level											
Lift mast											
Check the mast bearings for damage and lubricate the mast bearings, and check the tightening torque											
Check the mast profiles for damage and wear, and lubricate the mast profiles											

At operating hours										Carried out	
1000		2000		4000		5000		7000		✓	*
8000		10000		11000		13000		14000			
Check the load chains for damage and wear, and adjust and lubricate the load chains											
Check the lift cylinder and connections for damage and leaks											
Check the guide pulleys for damage and wear											
Check the support rollers and chain rollers for damage and wear											
Check the play between the fork carriage stop and the run-out barrier											
Check the tilt cylinder and connections for damage and leaks											
Check the fork carriage for damage and wear											
Check the fork arm interlock for damage and correct function											
Check the fork arms for wear and deformation											
Check that there is a safety screw on the fork carriage or on the attachment											
Special equipment											
Check the heating system for damage, clean the air filter and replace as required; observe the manufacturer's maintenance instructions											
Check the attachments for wear and damage; observe the manufacturer's maintenance instructions											
Check the trailer coupling for wear and damage; observe the manufacturer's maintenance instructions											
General											
Read out error numbers and delete the list											
Reset the maintenance interval											
Check labelling to ensure it is complete											
Perform a test drive											

Maintenance — 3000 hours/every two years

At operating hours							Carried out	
3000	6000	9000	12000	15000			✓	*
Note								
Perform all 1000-hour maintenance work.								
Power unit								
Gearbox oil: Change the gearbox oil								
Internal combustion engine								
Replace toothed belt, spur gears and V-belt								
Replace water pump, (recommendation, consult operating company)								
Replace air filter and fine filter								
Check coolant, top up if necessary, replace every 9000 hours or every 5 years								
LPG system								
Change all the hoses on the LPG system								
Hydraulics								
Change the hydraulic oil								
Replace the return line filter, breather filter and high-pressure filter (variant)								

Ordering spare parts and wearing parts

Spare parts are provided by our spare parts service department. The information required for ordering parts can be found in the spare parts list.

Only use spare parts as per the manufacturer's instructions. The use of unapproved spare parts can result in an increased risk of accidents due to insufficient quality or incorrect assignment. Anyone using unapproved spare parts shall assume unlimited liability in the event of damage or harm.

General maintenance information

Quality and quantity of the required operating materials

Only the operating materials specified in the maintenance data table may be used.

- The required consumables and lubricants can be found in the maintenance data table.

Oil and grease types of a different quality must not be mixed. This negatively affects the lubricity. If a change between different manufacturers cannot be avoided, drain the old oil thoroughly.

Before carrying out lubricating work, filter changes or any work on the hydraulic system, carefully clean the area around the part involved.

When topping up working materials, use only clean containers!

Lubrication plan



Code ¹	Lubrication point
(A)	Four lubricating nipples on each side of the steering axle for the axle stub bearing and track rod bearings
(B)	Sliding surfaces on the lift mast
(C)	Load chains
(D)	One lubricating nipple on each of the two lift mast bearings
¹ See the following chapter, "Maintenance data table", under this Code. for the respective lubricant specification This lubrication plan describes the series-production truck with standard equipment. For maintenance points on variant trucks, see the relevant chapter and/or instructions provided by the manufacturer.	

General maintenance information

Maintenance data table

General lubrication points

Code	Unit	Operating material	Specification	Quantity
	Lubrication	High-pressure grease	ID no. 0147873	As required

Controls/joints

Code	Unit	Operating material	Specification	Quantity
	Lubrication	High-pressure grease	ID no. 0147873	As required
		Oil	SAE 80 MIL-L2105 API GL-4	As required
	Dual-pedal operation	High-pressure grease	ID no. 0147873	As required

Battery

Code	Unit	Operating material	Specification	Quantity
	System contents	Distilled water		As required
	Insulation resistance		For further information, refer to the workshop manual for the truck in question.	

Electrical system

Code	Unit	Operating material	Specification	Quantity
	Insulation resistance		For further information, refer to the workshop manual for the truck in question.	

Hydraulic system

Code	Unit	Operating material	Specification	Quantity
	System contents	Hydraulic oil	HVLP 68 DIN 51524, part 3	Max. 30 l
		Hydraulic oil for the food industry (variant)	USDA H1 DIN 51524	

Tyres

Code	Unit	Operating material	Specification	Quantity
	Superelastic tyres	Wear limit		To wear mark
	Solid rubber tyres	Wear limit		To wear mark
	Pneumatic tyres	Minimum tread depth		1.6 mm
		Air pressure		See information on truck

Steering axle

Code	Unit	Operating material	Specification	Quantity
	Wheel nuts/screws	Torque wrench		For further information, refer to the workshop manual for the truck in question.
	Axle stub nuts	Torque wrench		For further information, refer to the workshop manual for the truck in question.
(A)	Axle stub bearings, track rod bearings	Grease	Aralub 4320 DIN 51825- KPF2N20 ID no. 0148659	Fill with grease until a small amount of fresh grease escapes

Drive axle

Code	Unit	Operating material	Specification	Quantity
	Wheel nuts/screws	Torque wrench		For further information, refer to the workshop manual for the truck in question.
	Wheel gear	Mineral oil	FUCHS TITAN GEAR HYP LD SAE 80W-90 API GL-5	
	Brake	Mineral oil	ARAL HGS FLUID 127830	

Lift mast

Code	Unit	Operating material	Specification	Quantity
(B)	Lubrication	High-pressure grease	ID no. 0147873	As required
	Stop	Play		Min. 2 mm

General maintenance information

Code	Unit	Operating material	Specification	Quantity
	Screws for the lift mast bearing	Torque wrench		For further information, refer to the workshop manual for the truck in question.
(D)	Lift mast bearing	Grease	Aralub 4320 DIN 51825- KPF2N20 ID no. 0148659	Fill with grease until a small amount of fresh grease escapes

Load chains

Code	Unit	Operating material	Specification	Quantity
(C)	Lubrication	High-load chain spray	Fully synthetic Temperature range: -35°C to +250°C ID no. 0156428	As required

Cooling system

Code	Unit	Operating material	Specification	Quantity
	System contents	Corrosion inhibitor and cooling system protecting agent/water	G12 plus TL-VW 774 F	Approx. 9 l

Fuel tank

Code	Unit	Operating material	Specification	Quantity
	System contents	Diesel fuel	EN 590, DIN 51628, ASTM D975, NATO F-54 non-road fuels (light fuel oils, EN 590 quality)	Approx. 58 l

Engine

Code	Unit	Operating material	Specification	Quantity
	System contents	Engine oil	VW 507.00	4.5 l, with filter change
	Air filter	Filter cartridge and safety cartridge		

Washer system

Code	Unit	Operating material	Specification	Quantity
	System contents	Washer fluid	Winter, ID no. 172566	As required

Providing access to maintenance points

Opening the bonnet

⚠ WARNING

Risk of injury!

- Switch off the engine before opening the bonnet!

⚠ CAUTION

When opening the bonnet, the driver's seat may be damaged if it is not moved as far forwards as possible.

- Slide the driver's seat all the way forwards.
- Move the steering column (1) as far forwards as possible and secure; see ⇒ Chapter "Adjusting the steering column", P. 4-80.
- Slide the driver's seat (2) all the way forwards; see ⇒ Chapter "Adjusting the MSG 65/MSG 75 driver's seat", P. 4-75.
- For trucks with a rear window (variant), fold the seat backrest forwards; see ⇒ Chapter "Adjusting the MSG 65/MSG 75 driver's seat", P. 4-75. Remove all protruding objects from the shelf.
- Firmly insert a narrow screwdriver into the slot (4) of the bonnet release until the interlock opens. In an emergency, the ignition and stop key can also be used for this purpose.
- Use the handle to open the bonnet.

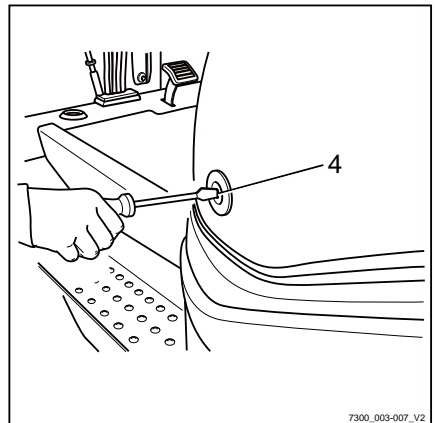
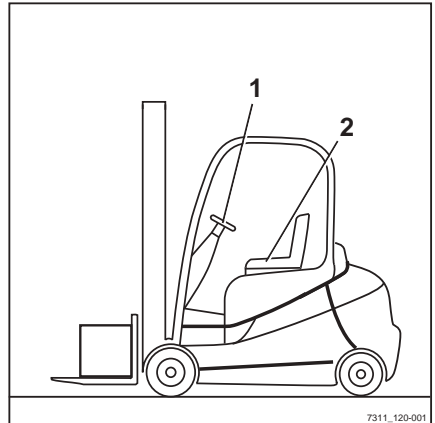

Closing the bonnet

- Holding it by the handle, pull down the bonnet until the lock audibly engages.

Providing access to maintenance points

- Adjust the seat (2); refer to → Chapter "Adjusting the MSG 65/MSG 75 driver's seat", P. 4-75. ▷
- Adjust the steering column (1).

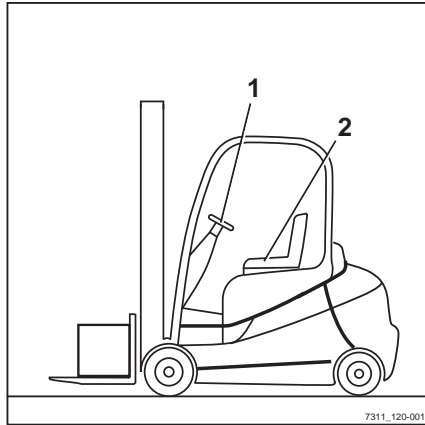

Installing and removing the bottom plate

Removing the bottom plate

⚠ CAUTION

Risk of short circuit if cables are damaged!

- Check the connection cables for damage.
- When removing and reinstalling the bottom plate, make sure that the connecting cables are not damaged.

i NOTE

The accelerator pedal is attached to the bottom plate and is removed with the bottom plate. The connecting plug for the accelerator is located underneath the bottom plate.

- Open the bonnet.
- Remove the rubber mat.

Providing access to maintenance points

- Lift the back of the floor plate (1).

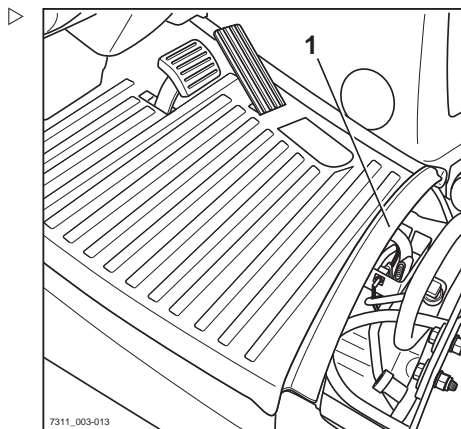

- Disconnect the plug connection from the accelerator pedal (2).
- Remove the floor plate and place it in a secure location.

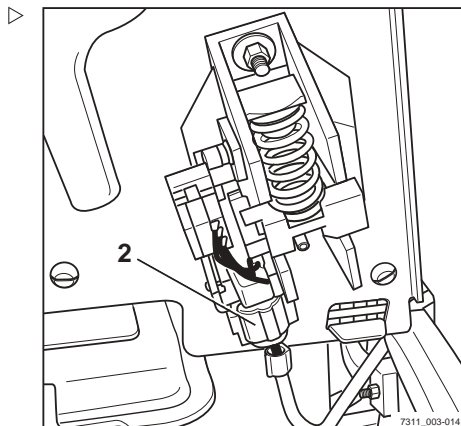
**Installing the bottom plate****⚠ WARNING**

Risk of crushing between the bottom plate and the frame edge!

If limbs or objects are between the bottom plate and frame edge when the bottom plate is closed, they can be crushed.

- Make sure that, when you close the bottom plate, there is nothing between the bottom plate and the frame edge.
-
- Position the bottom plate at the front.
 - Connect the connection assembly to the accelerator pedal.
 - Carefully guide the bottom plate down and close.
 - Insert the rubber mat.

Maintenance after first 50 operating hours

Maintenance after first 50 operating hours**Maintenance during the break-in period**

- Check status and tension of V-ribbed belt (1) ; see ⇒ Chapter "Checking the ribbed V-belt", P. 5-343.
- Check exhaust system; see ⇒ Chapter "Checking the exhaust gas system", P. 5-343.

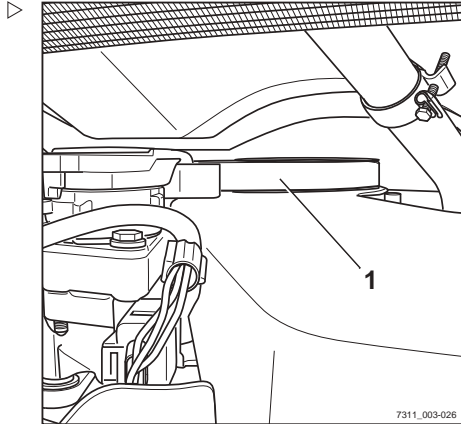

Remaining ready for operation

Cleaning the radiator, checking for leaks

- Park the truck securely.
- Open the bonnet.
- Clean the radiator (1).
- Clean the radiator fins using a suitable brush and blow them out using compressed air (max. 2 bar).
- Check the radiator and coolant hoses for leaks and tighten the clips if necessary.

⚠ CAUTION

Risk of engine damage!

If the cooling fluid level is low, this indicates a leak in the cooling system.

- Check whether the leakage has been eliminated.
- If not, notify the authorised service centre.

- Close the bonnet.

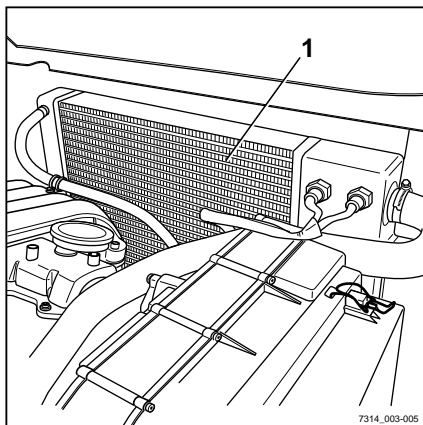

7314_003-005

Topping up the cooling fluid and checking the coolant concentration

⚠ CAUTION

Risk of engine damage!

If the cooling fluid level is low, this indicates a leak in the cooling system.

- Check the cooling system for leaks; see the chapter entitled "Cleaning the radiator".

⚠ WARNING

Risk of scalding!

Cooling fluid is very hot. There is a risk of scalding.

- Open the filler cap (1) on the cooling fluid reservoir only when the engine is cool.

Remaining ready for operation

- Slowly open the filler cap (1) and release over pressure. ▷
- Remove the filler cap.

⚠ WARNING

Cooling fluids and coolants are hazardous to your health.

- Observe the safety regulations for handling the cooling fluid; see the section entitled "Cooling fluid".
-
- Check the concentration of the coolant.

Concentration of the coolant

⚠ CAUTION

Risk of corrosion!

The percentage of coolant must always be at least 40%, even if frost protection is not needed in warmer climates.

If greater frost protection is required for climatic reasons, the percentage of coolant can be increased to up to 60%.

The percentage of coolant must not exceed 60%, otherwise the frost protection is reduced. In addition, the cooling effect is also reduced.

Only use clean, softened water for the water percentage.

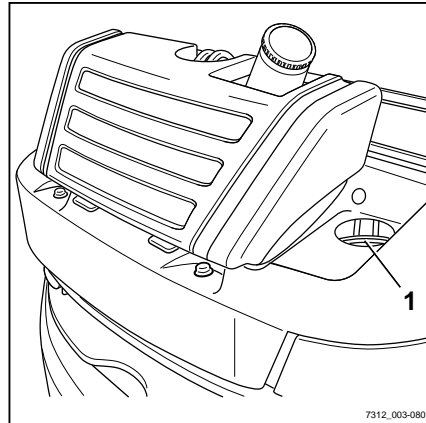

Frost protection up to °C	Water percentage %	Coolant percentage %
-25	60	40
-30	55	45
-35	50	50
-40	40	60

For details of the filling quantity in the cooling system, see the section entitled "Maintenance data table".

⚠ CAUTION

Coolant with a different specification must not be mixed in!

- When topping up, use the coolant listed in the maintenance data table.

Only use coolant additive according to the manufacturer's guidelines.

- Screw the filler cap (1) back on tightly.

Changing the air filter insert

NOTE

The air filter insert must be changed if the AIR FILTER message appears on the display and operating unit, or at least every 3000 hours or every two years.

- Open the bonnet; see the chapter entitled "Opening the bonnet".

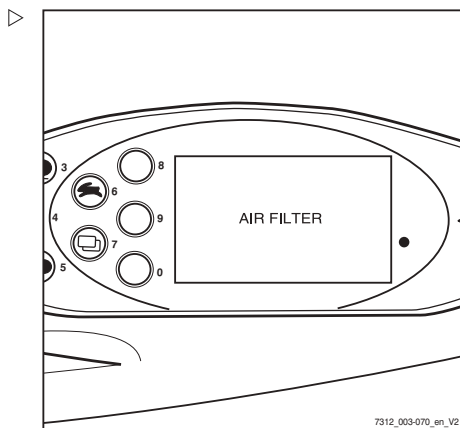

- Loosen the clamps (1) on the air filter housing.

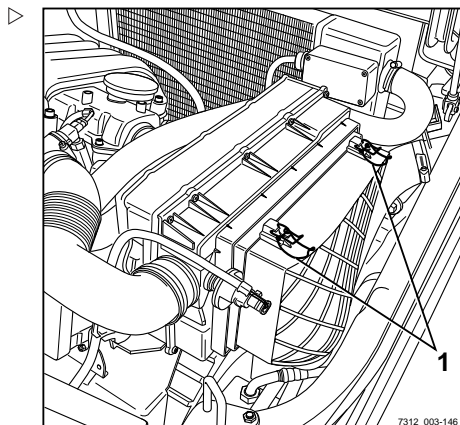

Remaining ready for operation

- Fold up the air filter cover (2).

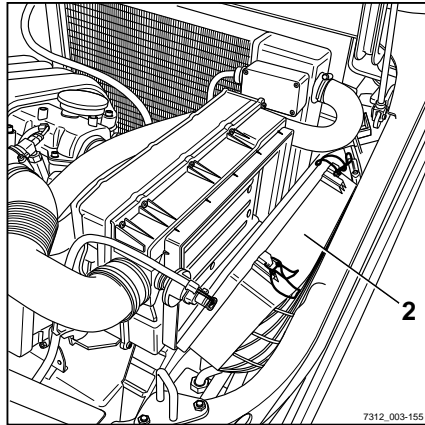

- Lift the air filter cover out of the truck so that the intake hose (3) is tilted downwards slightly.

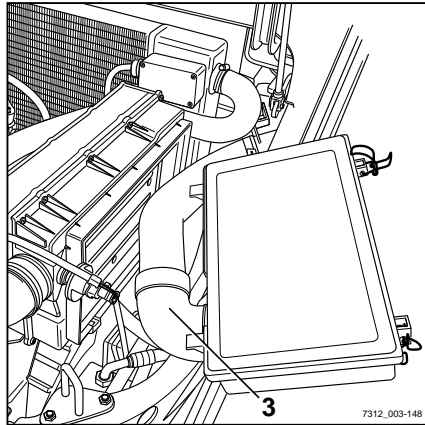

⚠ CAUTION

Risk of damage from contamination!

- When taking out the filter insert, block the intake opening (6) using a lint-free cloth.



NOTE

It is recommended that you change the filter insert instead of cleaning it. Frequent cleaning can result in damage to the filter insert. Such damage poses the risk of dust getting into the engine.

- Remove the filter insert (4). Ensure that no dirt can enter the intake opening (6).
- Wipe out the air filter housing using a damp cloth.
- Check the filter insert (4) for contamination or damage, and change it if necessary.

⚠ CAUTION

Risk of damage to components from contamination!
Damaged filter inserts must be changed to avoid engine damage.

- Remove the cloth (6) from the intake opening.
- Fit the air filter cover (2) from above at an angle and install in the truck using a swivel movement. Ensure that the sealing lip (5) of the filter insert is seated correctly in the housing.
- Allow the clamps (1) on the air filter housing to engage.
- Close the bonnet.

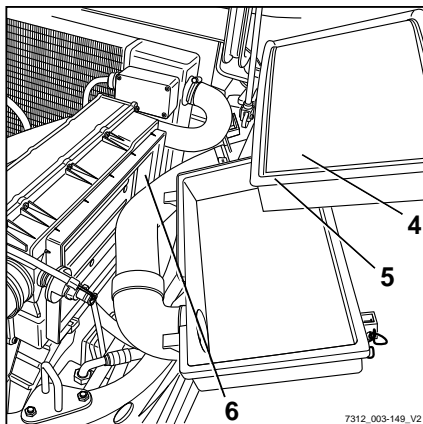

Draining water from the fuel filter



⚠ WARNING

Consumables are toxic.

Observe safety regulations when handling Diesel fuel, see ⇒ Chapter "Diesel fuel", P. 2-48.

- Open the bonnet, see ⇒ Chapter "Opening the bonnet", P. 5-317.
- Hold a suitable collection vessel under the drainage screw (1).
- Open the drainage screw (1) on the filter and drain the fuel (approx. 100 cm³) until clean fuel is discharged.
- Manually retighten the drainage screw (1).
- Close the bonnet.

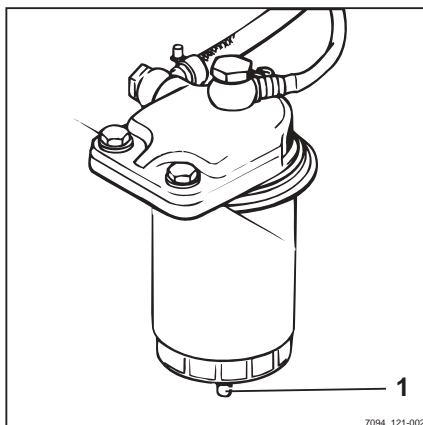

Remaining ready for operation

NOTE

Draining this water is particularly important when operating in the tropics and depending on the quality of fuel used.

NOTE

A second fuel filter (variant) can be installed. Both filters must be drained.

Eberspächer particle filters - Regeneration ▷

After an engine has been operating for approx. 7.5 hours, the EXH. GAS PURIFIER message appears in the display and operating unit. The particle filter must be regenerated. The operating device is integrated into the display and operating unit.

NOTE

The buttons (1) and the corresponding symbols are assigned according to the auxiliary equipment installed. The assignment shown here is an example and can deviate on the actual truck.

NOTE

If particulate filter regeneration remains off for longer than 30 minutes, an acoustic signal is emitted (variant). The acoustic signal is ended when regeneration starts.

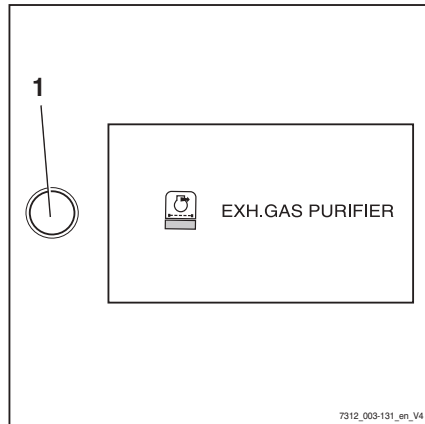

Regeneration emergency off switch



⚠ DANGER

There is a risk of fire if smoke is emitted!

If smoke is emitted during regeneration, this may be caused by a fire. The diesel supply is cut off and regeneration is interrupted when the emergency off switch (1) is pressed.

- If smoke is emitted, press the emergency off switch immediately.

Regenerating the particle filter

- Park in a suitable parking space.



⚠ DANGER

Risk of fire!

The parking space must not be in an area containing hazardous materials or in a hall, because hot combustion gases are produced from the exhaust pipe during regeneration.

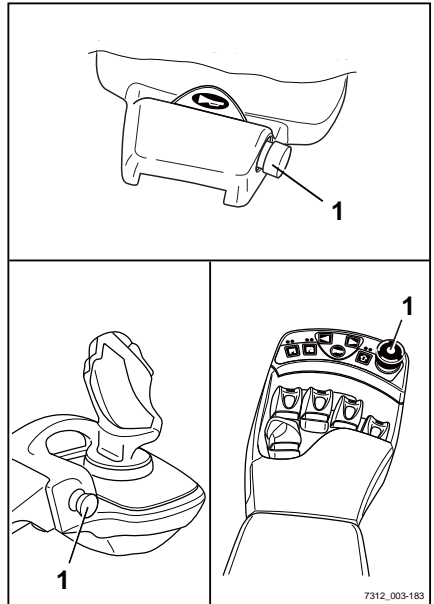

i NOTE

Combustion may cause bad odours if fuel containing sulphur was used for operating the engine.

i NOTE

It is not possible to start the engine during regeneration.

The regeneration must be started manually with the engine switched off and the ignition switched on.

A safety circuit prevents regeneration when the engine is running as the particle filter system might be destroyed.

- Switch off the engine and place the key switch in position "I".

Remaining ready for operation

- Press and hold the button (1) assigned to the symbol .

The particulate filter regeneration process is started and runs automatically.

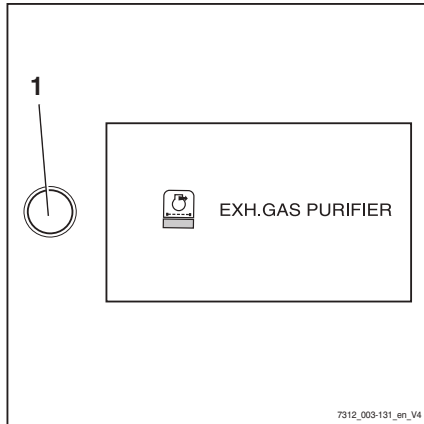

EXH. GAS PURIFIER PLEASE WAIT appears on the display. The status bar (4) below the message indicates the regeneration progress.

- Once the regeneration process has started, switch the key switch to position "0".

NOTE

If the ignition is not turned off, this can lead to the starter battery discharging after regeneration is complete if the truck is not put back into service straight-away.

After approx. 25 minutes the regeneration is complete. The EXH. GAS PURIFIER PLEASE WAIT message disappears. The filter is free of soot again.

If the burner flame goes out during the regeneration process, the control unit will automatically attempt to start up again.

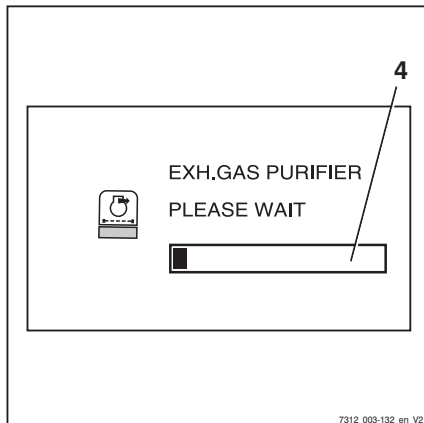

Malfunctions during the regeneration process are indicated by the message EXH. GAS PURIFIER along with the corresponding error code. The malfunctions must be rectified by the authorised service centre.

- Notify the authorised service centre.

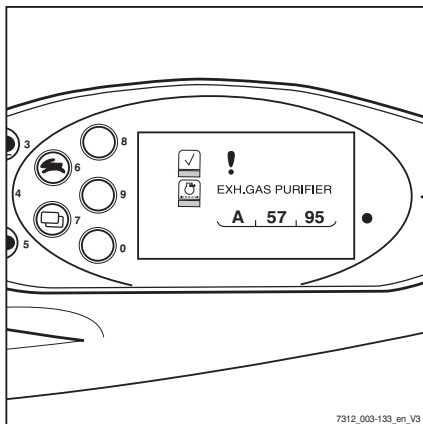

Lubricating the joints and controls

- Oil or grease other bearing points and joints according to the maintenance data table; see → Chapter "Maintenance data table", P. 5-314.
- Driver's seat guide
- Lubricate bonnet hinges at the lubricating nipple
- Control linkage for valves
- In the cab, lubricate door hinges at the lubricating nipple (variant)
- Lubricate shafts and joints in dual-pedal operation (variant)

Remaining ready for operation

Maintaining the seat belt

⚠ DANGER

There is a risk to life if the seat belt fails during an accident!

If the seat belt is faulty, it may tear or open during an accident and no longer keep the driver in the driver's seat. The driver may therefore be hurled against the truck components or out of the truck.

- Ensure operational reliability by continually testing.
- Do not use a truck with a defective seat belt.
- Only have a defective belt replaced by your service centre.
- Only use genuine spare parts.
- Do not make any changes to the belt.

i NOTE

Carry out the following checks on a regular basis (monthly). In the case of significant strain, a daily check is necessary.

Checking the seat belt

- Pull out the belt (3) completely and check for wear. ▷

The belt must not be frayed or cut. The stitching must not be loose.

- Check whether the belt is dirty.
- Check whether parts are worn or damaged, including the attachment points.
- Check the buckle (1) to ensure that it locks in properly.

When the belt tongue (2) is inserted, the belt must be held securely.

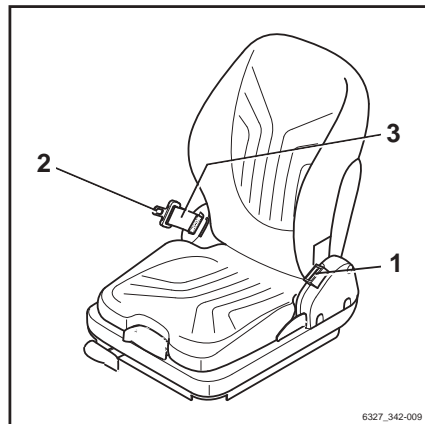

6327_342-009

- The belt tongue (2) must release when the red button (4) is pressed. ▷
- The automatic blocking mechanism must be tested at least once a year:
- Park the forklift truck on level ground.
- Pull out the belt with a jerk.

The automatic blocking mechanism must block extension of the belt.

- Tilt the seat at least 30 ° (if necessary, remove the seat).
- Slowly extend the belt.

The automatic blocking mechanism must block extension of the belt.

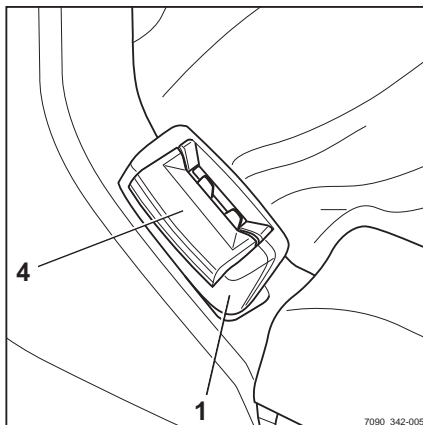

Cleaning the seat belt

- Clean the seat belt as necessary, but without using chemical cleaning materials (a brush will suffice).

Replacement after an accident

As a rule, the seat belt must be changed after an accident.

Checking the driver's seat ▷

⚠ WARNING

Risk of injury!

- After an accident, check the driver's seat with attached restraining belt and fastening.
-
- Check the controls for correct operation.
 - Check the condition of the seat (e.g. wear on the upholstery) and secure fastening to the hood.

⚠ WARNING

Risk of injury!

- Have the seat repaired by the service centre if you identify any damage during the checks.

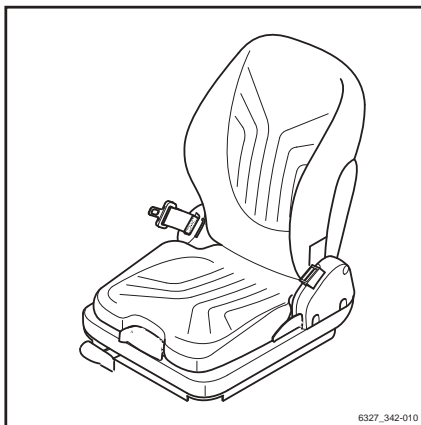

Remaining ready for operation

Checking the door latch

- Inspect the condition of the catch bolt and check for wear.
- Check the lock mechanism for easy operation.

Servicing wheels and tyres

⚠ WARNING

Risk of accident!

Uneven wear reduces the stability of the truck and increases the braking distance.

- Worn or damaged tyres (left or right) must be replaced immediately.

⚠ WARNING

Risk of tipping!

Tyre quality affects the stability of the truck.

If you wish to use a different type of tyre on the truck from the tyres approved by the truck manufacturer, or tyres from a different manufacturer, you must first obtain approval from the truck manufacturer.

⚠ WARNING

Risk to stability!

When using pneumatic tyres or solid rubber tyres, rim wheel parts must never be changed and rim wheel parts from different manufacturers must not be mixed.

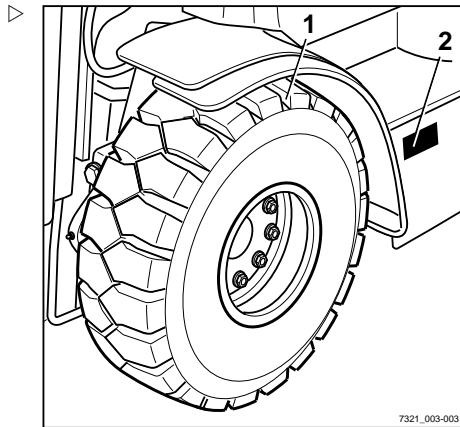

7321_003-003

Checking air pressure

- Check the air pressure of all four tyres; adjust if necessary.

i NOTE

The correct air pressure for pneumatic tyres (variant) is determined by the type of tyres used. Observe the information on the adhesive labels (2) on the truck.

Checking condition and wear of the tyres ▷

⚠ WARNING

Tyre quality affects the stability and handling of the truck.

Changes can only be made in consultation with the manufacturer.

When changing wheels or tyres, always ensure that this does not cause the truck to tilt to one side (e.g. always change right and left wheels at the same time).

i NOTE

The wear of the tyres on an axle must be approximately the same.

- *The tread depth (1) for pneumatic tyres must be **at least 1.6 mm** at every point on the tread.*
- *Super-elastic tyres (variant) can be worn down to the wear mark (3).*
- Check the tread depth on all four tyres.
- Check distance between the tyre tread and the wear mark.
- Remove any foreign bodies imbedded in the tyre tread.

Checking wheel fastenings

- Check that the wheel fastening (4) is securely fastened and retighten as necessary.
- Observe the torques; see the "maintenance data table" ▷

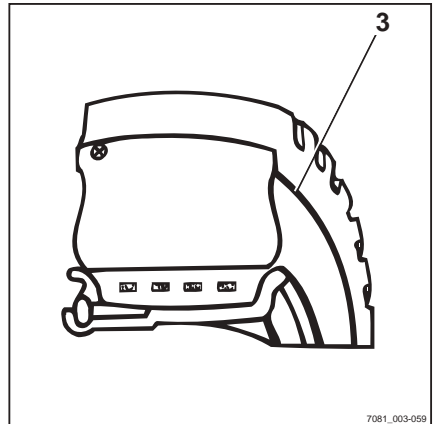

7081_003-059

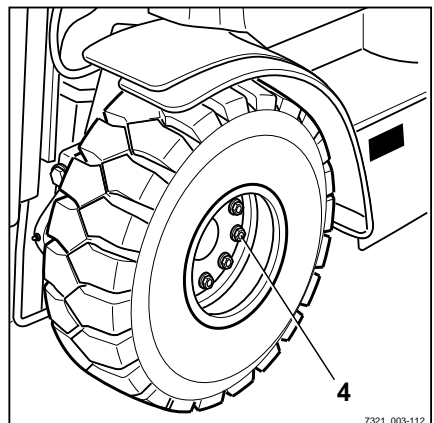

7321_003-112

Remaining ready for operation

Servicing the battery

NOTE

Battery maintenance is carried out in accordance with the battery manufacturer's operating manual!



WARNING

There is a risk of damage, short circuit and explosion.

Do not place any metal objects or tools on the battery. Keep away from naked flames and fire. Smoking is forbidden.

Checking the battery charge status

- Remove the bottom plate; see ⇒ Chapter "Installing and removing the bottom plate", P. 5-318

Mind the accelerator as you do so.

- With maintenance-free batteries, check the charge status at the inspection window (1): 

- **Green:** The battery is optimally charged.
- **Black:** The battery charge status is no longer optimal. The battery should be recharged. After recharging, the indicator changes back to green.
- **Transparent-(light-coloured):** The charge status is no longer adequate for reliable starting. It is necessary to change the battery.

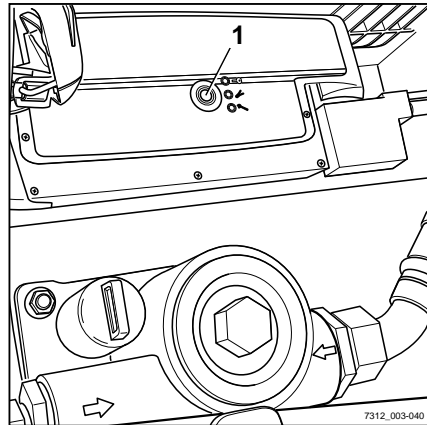

Charging the battery

- With batteries that are not maintenance-free, check the level of the battery acid.



WARNING

The electrolyte (dilute sulphuric acid) is poisonous and caustic.

- Follow the safety regulations for working with battery acid; see ⇒ Chapter "Battery acid", P. 2-47.

- Check battery acid level.

The battery acid must be up to the lower edge of the insert in the battery housing or up to 5 mm above the upper edge of the plates. Observe the manufacturer's specifications!

⚠ CAUTION

The battery can be damaged!

- Fill up missing fluid with distilled water only.

- Unscrew the battery cell cover and check the acid density with an acid siphon.

The acid density must achieve the value in the table. The listed density of the acid refers to 27°C acid temperature.

Acid density	Empty	Full
Normal	1.13	1.28
Tropics	1.08	1.23



⚠ WARNING

Risk of explosion! Charging releases gases that are explosive.

While charging, the surfaces of the battery cells must be free to ensure sufficient ventilation.

The charging area must be properly ventilated.

Keep bonnet open during charging; avoid spark formation near the battery.

- Charge discharged batteries immediately until they are fully charged again.

The charging current shall not exceed 1/10 of capacity.

The cell covers of the batteries must be kept dry and clean.

Any spillage of battery acid must be neutralised immediately.

Terminals and lugs must be clean, lightly coated with battery grease and tightly screwed.

- After charging, screw the cell covers back on.

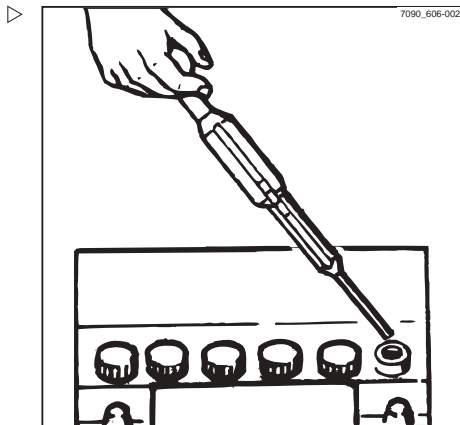

Remaining ready for operation

- Fit the bottom plate, see ⇒ Chapter "Installing and removing the bottom plate", P. 5-318.

Replacing fuses

▲ DANGER

Risk of fire!

Using the wrong fuses can result in short circuits.

- Use only fuses with the prescribed nominal current, see the section entitled "Fuse assignment".
- Remove the cover at the back.
- Open the cover fastenings (1) and remove the cover.
- Replace the defective fuse with one that is rated for the nominal current according to "Fuse assignment".
- Close the cover to secure the fuse box.
- Install the back covers.
- Perform a function check. If the error persists or if the fuse is still defective, notify your authorised service centre.

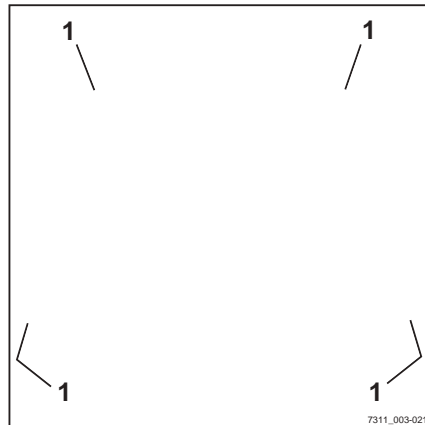

Checking the hydraulic oil level

▲ CAUTION

Hydraulic oils are hazardous to your health and are under pressure during operation.

- Note safety regulations for working with hydraulic oils; see ⇒ Chapter "Hydraulic fluid", P. 2-46.
- Park the truck securely; see ⇒ Chapter "Parking the truck securely and switching it off", P. 4-141.
- Open the bonnet; see ⇒ Chapter "Opening the bonnet", P. 5-317.

- Unscrew breather filter with oil dipstick (1). ▷

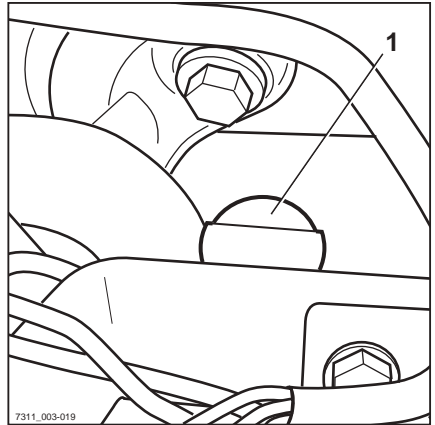

- Check the oil level. The oil level must be at least up to the mark (2) on the dipstick. ▷
- If the oil level does not reach the specified level, pour hydraulic oil of the corresponding specification (see ⇒ Chapter "Maintenance data table", P. 5-314) into the filler neck until it reaches the upper marking as a maximum.

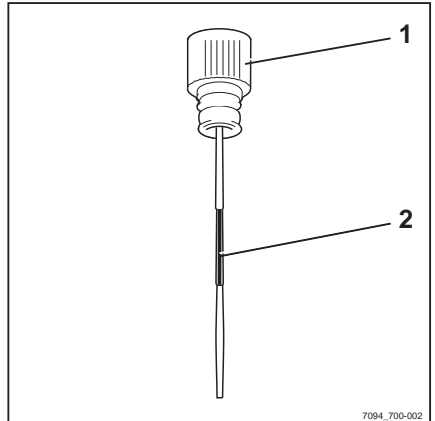

i NOTE

Use a funnel.

- Screw in the breather filter with oil dipstick.
- Close bonnet again.

♻️ ENVIRONMENT NOTE

Carefully collect up any spilled oil and dispose of it in an environmentally friendly manner.

Checking the hydraulic system for leaks



⚠️ WARNING

Hydraulic oil under pressure can escape from leaking lines and cause injuries to the skin.

Wear suitable protective gloves, industrial goggles etc.

Remaining ready for operation

⚠ WARNING

Hydraulic hoses become brittle!

Hydraulic hoses should not be used longer than 6 years.

The specifications of BGR 237 should be complied with. Deviating national laws are to be taken into account.

- Check pipe and hose connection screw joints for leaks (traces of oil).

Hose lines must be changed if:

- The outer layer has been breached or becomes brittle with tears
- They are leaking
- There are unnatural deformations (e.g. bubble formation or buckling)
- A fitting is detached from the hose
- A fitting is badly damaged or corroded

Pipes must be changed if:

- There is abrasion with the loss of material
- There are unnatural deformations and detectable bending stress
- They are leaking

Lubricating the lift mast and roller track

- Remove dirt and lubricant residue from the roller track.
- Lubricate the roller tracks (1) of the outside, middle, and inside mast with a super-pressure adhesion lubricant to reduce wear. See ⇒ Chapter "Maintenance data table", P. 5-314.

i NOTE

Spray the roller track evenly from a distance of approx. 15-20 cm. Wait approx. 15 minutes until the equipment is ready to use again.

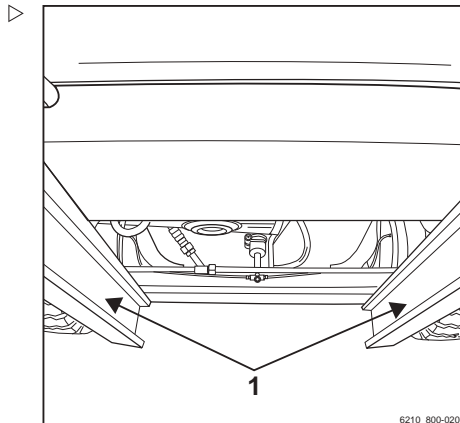

Greasing the automatic tow coupling

NOTE

Wear to moving parts can be significantly reduced by appropriate servicing and regular lubrication of the coupling.

- Avoid over-greasing!

NOTE

Close the coupling before cleaning with a high-pressure cleaner. After cleaning, lubricate the coupling pin, tow bar eye and its supporting surface again.

Model RO*243

- Pull out the safety handle (3).
- Push the hand lever (2) upwards.
- Grease using the lubricating nipple(1) in accordance with the maintenance data table; see → Chapter "Maintenance data table", P. 5-314.
- Close the coupling by raising the coupling pin with a suitable tool.
- For journeys with a rigid drawbar trailer, lubricate the underside of the tow bar eye and the supporting surface on the coupling.

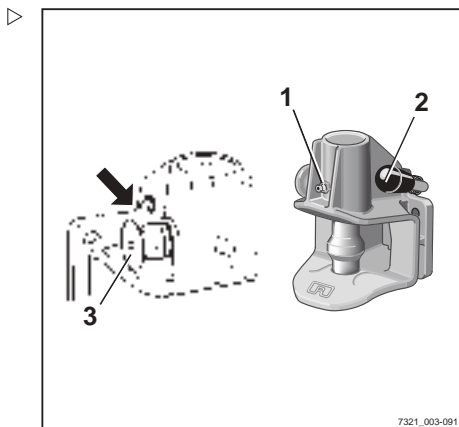

- Determine the wear on the coupling pin.

The diameter of the spherical part must not be less than 36.5 mm.

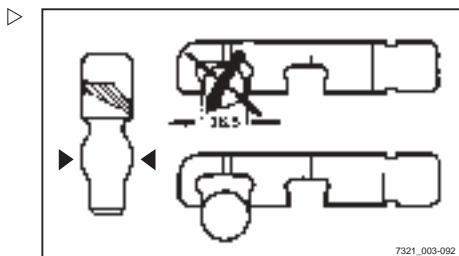

Model RO*244 A

- Open coupling.

Remaining ready for operation

- Grease using the lubricating nipple(1) in accordance with the maintenance data table; see ⇒ Chapter "Maintenance data table", P. 5-314.
- Grease coupling pin, tow bar eye and its supporting surface.

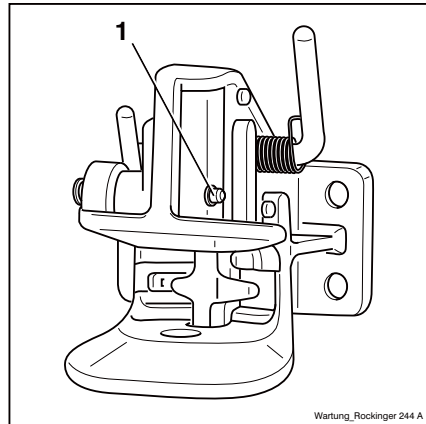
**Model RO*245**

- Lubricate via the points provided for this purpose (lubricating nipple, opened coupling) in accordance with the maintenance data table; see ⇒ Chapter "Maintenance data table", P. 5-314.
- Grease the supporting surface for the tow-bar eye.

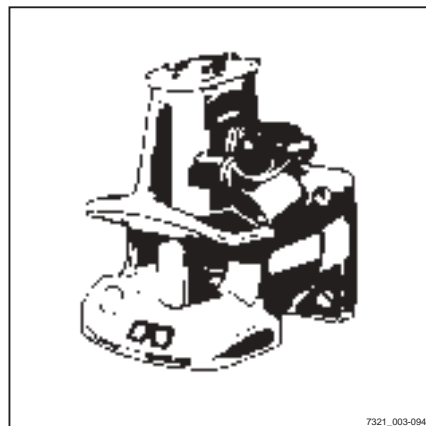

Model RO*841

- Lubricate via the points provided for this purpose (lubricating nipple, opened coupling) in accordance with the maintenance data table; see ⇒ Chapter "Maintenance data table", P. 5-314.
- Grease the supporting surface for the tow-bar eye.

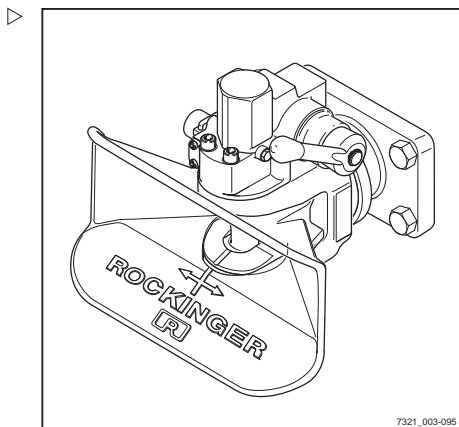

Changing the heating system fresh air filter

- Open the cab door to the right.
- Loosen the mounting screws (1) and remove the cover (2).
- Check the filter mat (3) for contamination.
- If the filter mat is grey in colour, replace it.

NOTE

Change the filter mat at least every 2 months.

- Clean the fresh-air inlet by removing dust and dirt.

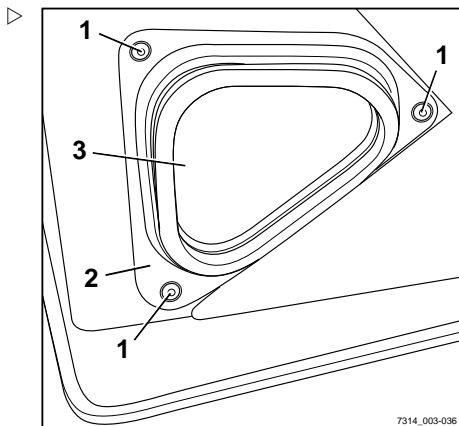

1000-hour maintenance / Annual maintenance

Other tasks

- Perform all maintenance work; see the "Maintenance" chapter.

Checking the ribbed V-belt

NOTE

If damage is identified, the ribbed V-belt must be replaced to prevent failure or functional problems.

- Crank the engine by hand while checking the ribbed V-belt (1) for the following:
 - Substructure cracks (initial cracks, core breaks, crosswise cracks)
 - Layer separation (top layer, tension members)
 - Blowout of the substructure
 - Fraying of the tension members
 - Edge wear (material removal, frayed edges, edge hardening, surface cracks)

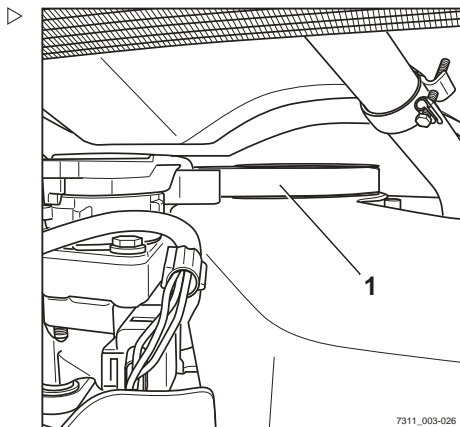

Checking the exhaust gas system

- Inspect the exhaust gas system for external damage, secure fit, and leaks.

1000-hour maintenance / Annual maintenance

Changing the fuel filter

**⚠ WARNING**

Consumables are toxic!

- Note safety regulations for working with diesel fuel; see ⇒ Chapter "Diesel fuel", P. 2-48.

- Open the bonnet; see ⇒ Chapter "Opening the bonnet", P. 5-317.
- Hold a suitable collection vessel beneath the fuel filter (1).
- Unscrew the fuel filter (1)

**ENVIRONMENT NOTE**

- *Dispose of fuel filter and the diesel fuel in accordance with applicable regulations.*

**NOTE**

A second fuel filter (variant) may be installed. Both filters must be replaced.

- Wet the sealing surface of the new fuel filter with diesel fuel and tighten the filter by hand
- Start the engine, see ⇒ Chapter "Starting the engine", P. 4-98.
- Check the fuel filter for leaks.
- Close the bonnet.

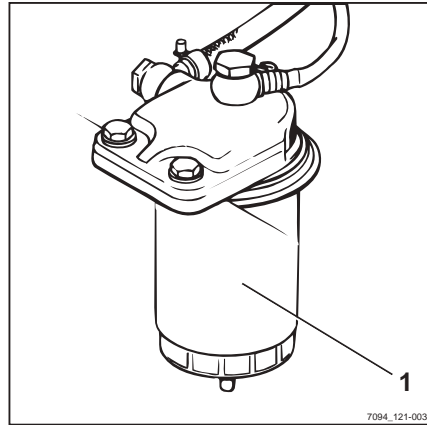

Changing the fuel filter for Eberspächer particle filters



⚠ WARNING

Consumables are toxic!

- Note safety regulations for working with diesel fuel; see ⇒ Chapter "Diesel fuel", P. 2-48.

- Release both clips (1) at the fuel filter (2).
- Change the fuel filter (2) and retighten the two clips (1).

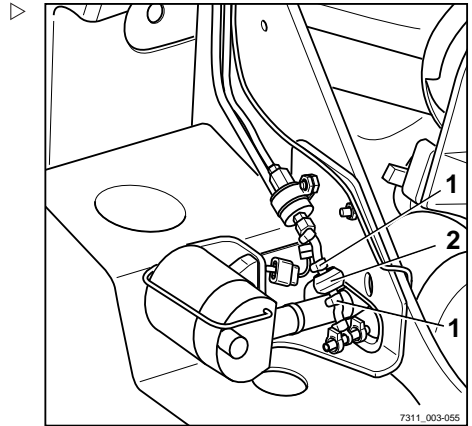

Checking the lift cylinders and connections for leaks

⚠ WARNING

Risk of injury

Observe safety regulations for working on the lift mast, see the "Working at the front of the truck" chapter.

- Check the hydraulic connections and lift cylinder for leaks (visual inspection).
- Have leaking screw joints or leaking hydraulic cylinders repaired by the authorised service centre.

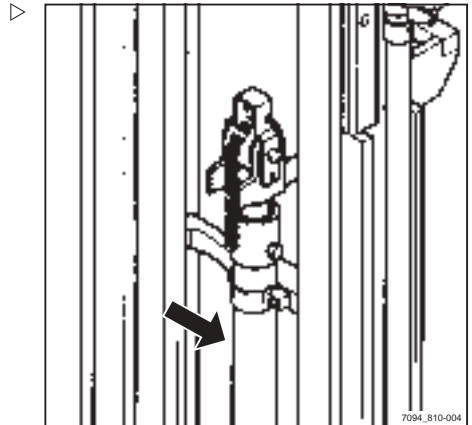

1000-hour maintenance / Annual maintenance

Checking the fork arms

- Check the fork arms (1) for visible deformation and excessive wear.

Wear must not amount to more than 10% of the original thickness.

- Check the fork latch (3) for correct operation.
- Check that the locking screw (2) is secured and cannot fall out of the fork arms.
- Replace any worn or deformed fork arms.

CAUTION

- Fork arms must not be uneven!
- Always replace both fork arms.

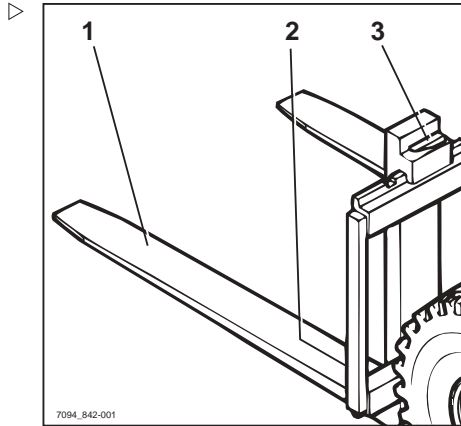

Checking the reversible fork arms

NOTE

This check is only required for reversible fork arms (variant).

- Check the outside of the fork bend (1) for cracks. Contact your service centre.

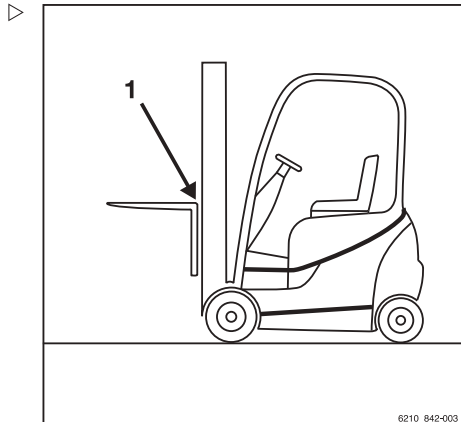

6

Technical data

Dimensions

Dimensions

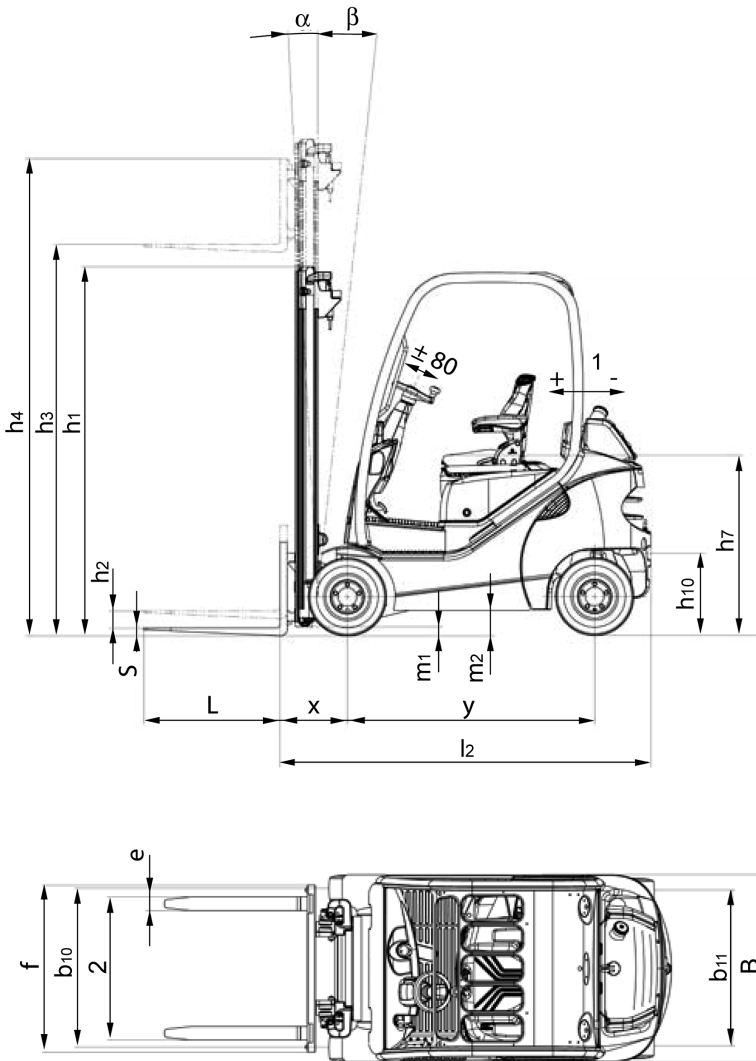

7311_003-072_V4

1 Seat is adjustable ± 90 mm

2 Fork spacing is adjustable

i NOTE

Measurements h_1 , h_3 , h_4 , h_6 and b_1 are specified by the customer and can be taken from the order confirmation.

Centre of gravity "S" (distance measured from the front axle)

RX70-16	791 mm
RX70-18	828 mm
RX70-20	837 mm

i NOTE

The specified centre of gravity "S" relates to trucks with standard equipment. If, for example, the truck is equipped with a different lift mast, attachment or driver protection structure, this value is only a guide value. If necessary, the centre of gravity "S" must be determined on an individual basis for each truck.

VDI datasheet for RX70-16, RX70-18 and RX70-20

VDI datasheet for RX70-16, RX70-18 and RX70-20

NOTE

This VDI datasheet specifies only the technical values of the truck version with standard equipment. Different tyres, lift masts, additional units etc. may produce different values.

Characteristics

Model		RX70-16	RX70-18	RX70-20
Type number		7311	7312	7313
Manufacturer		STILL GmbH	STILL GmbH	STILL GmbH
Drive		Diesel	Diesel	Diesel
Operation		Seated	Seated	Seated
Load capacity/load	Q (kg)	1600	1800	2000
Load centre of gravity distance	c(mm)	500	500	500
Load distance	X (mm)	395	395	405
Wheelbase	Y (mm)	1450	1487	1526

Weights

Model		RX70-16	RX70-18	RX70-20
Type number		7311	7312	7313
Net weight	kg	2706	2856	3059
Axle load with front load	kg	3817	4149	4568
Axle load with rear load	kg	489	507	491
Axle load without front load	kg	1230	1266	1382
Axle load without rear load	kg	1476	1590	1677

Wheels, chassis frame

Model		RX70-16	RX70-18	RX70-20
Type number		7311	7312	7313
Tyres		SE	SE	SE
Front tyre size		18x7-8	18x7-8	200/50-10

Model		RX70-16	RX70-18	RX70-20
Type number		7311	7312	7313
Rear tyre size		18x7-8	18x7-8	18x7-8
Number of front wheels (x = driven)		2x	2x	2x
Number of rear wheels (x = driven)		2	2	2
Front track width	b10 (mm)	932	932	942
Rear track width	b11 (mm)	895	895	895

Basic dimensions

Model		RX70-16	RX70-18	RX70-20
Type number		7311	7312	7313
Tilt of lift mast/fork carriage, forwards	Degree	3	3	3
Tilt of lift mast/fork carriage, backwards	Degree	8	8	8
Height with lift mast retracted	h1 (mm)	2160	2160	2160
Free lift	h2 (mm)	150	150	150
Lift height	h3 (mm)	3230	3230	3150
Height with lift mast extended	h4 (mm)	3873	3873	3725
Height to top of overhead guard	h6(mm)	2117	2117	2117
Seat height	h7(mm)	1015	1015	1015
Coupling height	h10 (mm)	474	474	474
Total length	l1 (mm)	2975	3012	3061
Length including fork back	l2 (mm)	2175	2212	2261
Total width	b1 (mm)	1099	1099	1138
Fork arm thickness	s (mm)	40	40	40
Fork arm width	e (mm)	80	80	80
Fork arm length	l (mm)	800	800	800
Fork carriage ISO 2328 class/form		II/A	II/A	II/A
Fork carriage width	b3 (mm)	980	980	980
Ground clearance with load under lift mast	m1 (mm)	90	90	90
Ground clearance at centre of wheelbase	m2 (mm)	133	133	133

VDI datasheet for RX70-16, RX70-18 and RX70-20

Model		RX70-16	RX70-18	RX70-20
Type number		7311	7312	7313
Aisle width for pallet 1000 x 1200 crosswise	Ast (mm)	3523	3557	3603
Aisle width for pallet 800 x 1200 lengthwise	Ast (mm)	3727	3762	3810
Turning radius	Wa(mm)	1926	1961	1998
Smallest pivot point distance	b13 (mm)	538	544	550

Performance data

Model		RX70-16	RX70-18	RX70-20
Type number		7311	7312	7313
Driving speed with load	km/h	22	22	22
Driving speed without load	km/h	22	22	22
Lifting speed with load	m/s	0.52	0.52	0.52
Lifting speed without load	m/s	0.54	0.54	0.54
Lowering speed with load	m/s	0.59	0.59	0.59
Lowering speed without load	m/s	0.59	0.59	0.59
Pulling force with load	N	13,000	13,000	13,000
Pulling force without load	N	6700	6700	6700
Climbing capability ¹ with load	%	27	26	26
Climbing capability without load	%	28	28	28
Acceleration time with load	s	4.9	5.0	5.1
Acceleration time without load	s	4.6	4.7	4.7
Service brake		electr./hydr.	electr./hydr.	electr./hydr.

⚠ CAUTION

To use the truck safely—with or without a load—the maximum ascending or descending gradient permitted for travel is 15%.

- If you have any questions, please contact the authorised service centre.

¹ The stated values are used only to compare performance of trucks in the same category. The gradient values in no way represent the normal daily operating conditions.

Engine

Model		RX70-16	RX70-18	RX70-20
Type number		7311	7312	7313
Engine manufacturer/model		VW/BXT	VW/BXT	VW/BXT
Engine power rating in accordance with ISO 1585	kW	28	28	28
Nominal speed	rpm	2350	2350	2350
Number of cylinders/displacement	cm ³	4/1900	4/1900	4/1900
Fuel consumption ² in accordance with the VDI cycle	l/h	1.9	2.0	2.2

Other

Model		RX70-16	RX70-18	RX70-20
Type number		7311	7312	7313
Traction controller type		Stilltronic	Stilltronic	Stilltronic
Working pressure for attachments	bar	230	230	230
Oil volume for attachments	l/min	30	30	30
Capacity of fuel tank	l	58	58	58
Noise level L _{pAZ} (driver's compartment) ³	dB (A)	74	74	74
Tow coupling, DIN type/model		Bolt	Bolt	Bolt

² With Blue-Q energy-saving program

³ Without cab. Values differ with a cab.

Ergonomic dimensions

Ergonomic dimensions

⚠ WARNING

Danger of impact injuries to the head!

If the head of the operator is located too close to the underside of the roof, the suspension of the driver's seat or an accident may cause the head to strike the overhead guard.

To avoid head injuries, a minimum distance of **40 mm** must be ensured between the underside of the roof and the head of the tallest operator.

To determine the actual head clearance, the operator must sit in the driver's seat and the seat suspension must be set to this driver's requirements.

Due to the individual nature of height and body weight as well as the wide variety of types of driver's seat and overhead guard, the minimum head clearance must be ensured in every truck.

The driver's compartment has been designed taking ergonomics in the workplace into account and in accordance with EN ISO 3411. In general, from the seat position, the operator has sufficient space to reach the operating devices safely, to operate the truck and to view the outline of the truck. Operators whose body size deviates from the specified dimensions on which EN ISO 3411 is based must be individually considered by the operating company.

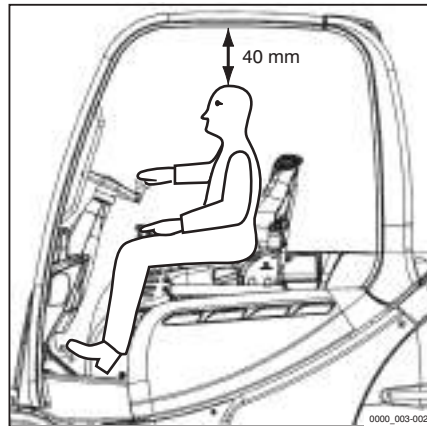

Fuse assignment

Fuse assignment

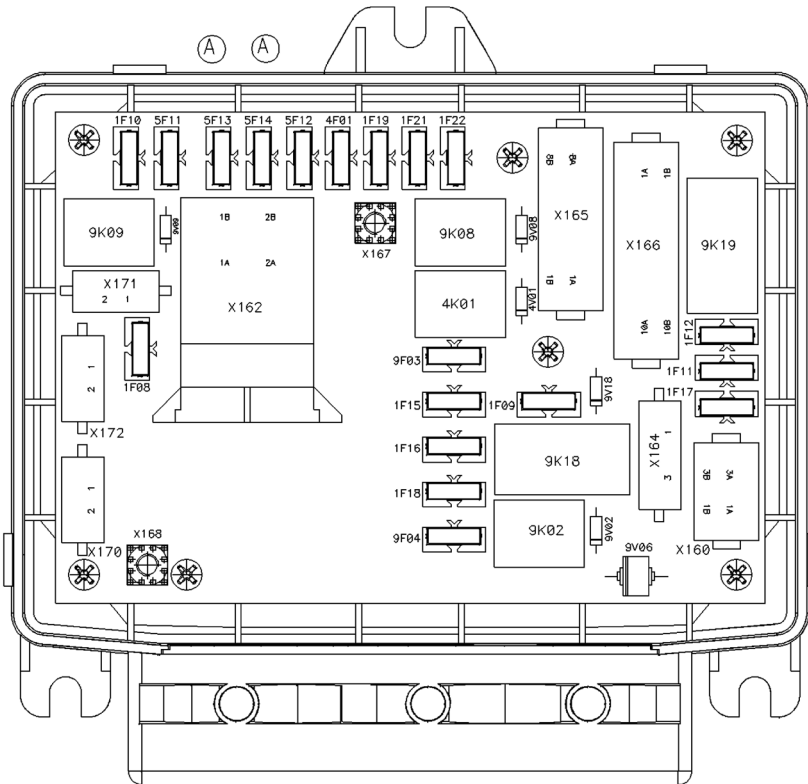

7311_003-073

1F08	12-V battery (constant positive terminal), variants, 10 A	1F18	12-V options, servo hydraulics, 10 A
1F09	Switch lock, 5 A	1F19	12-V engine control unit ECU, 10 A
1F10	Cooling fluid pump, 10 A	1F21	Engine control unit components, 15 A
1F11	Converter, 5 A	1F22	Engine control unit components, 15 A
1F12	Pump, variant, 10 A	4F01	Signal horn, 10 A
1F15	12 V for TCU, display and operating unit, 5 A	9F03	12-V Option Board, 15 A
1F16	12-V options, servo hydraulics, 10 A	9F04	Starter, terminal 50, 30 A
1F17	Time-delay relay, terminal 15, 10 A	9F6	Engine glow plug relay (diesel trucks only), 50 A

i NOTE

Depending on the specification, not all fuses will be present in the truck.

A

Access authorisation	
Changing the password	91
Defining the driver PIN	87
Entering the access code	85
Selecting the driver PIN	88
Access authorisation with PIN code	84
Accessories	
Overview	7
Actuating the drive direction switch	
Fingertip version	124
Joystick 4Plus version	124
Mini-console version	125
Mini-lever version	123
Actuating the parking brake	
When the truck is moving	137
Address of manufacturer	I
Adjusting the armrest	79
Adjusting the fork	171
Adjusting the steering column	80
After washing	279
Aisle widths	119

Attachments

Assembly	182
Controlling using a double mini-lever	188
Controlling using the double mini-lever and the 5th function	190
Controlling using the joystick 4Plus and the 5th function	201
Controlling using the quadruple mini-lever and the 5th function	198
Controlling using the triple mini-lever and the 5th function	194
Controlling via the joystick 4Plus	200
Controlling with a quadruple mini-lever	196
Controlling with a triple mini-lever	192
Controlling with the fingertip	202
Controlling with the fingertip and 5th function	203
General controlling	186
Mounting	183
Releasing the pressure from the connections	184
Special risks	35
Taking up a load	208
Automatic lift cut out	143
Automatic tow coupling	234
Coupling RO*243	236
Coupling RO*244 A	238
Coupling RO*245	240
Coupling RO*841	241
Uncoupling RO*243	237
Uncoupling RO*244 A	239
Uncoupling RO*245	241
Uncoupling RO*841	242

B**Battery**

Charging	334
Checking the charge status	334
Disposal	22
Servicing	334
Battery acid	47

Before taking up load	166	Closing the bonnet	317
Blue-Q		Closing the cab door	224
Configure	113	Closing the side windows	225
Functional description	115	Condition of the roadways	121
Switching off	116	Consumables	45
Switching on	116	Coolant and cooling fluid safety information	50
Bottom plate		Disposal	50
Installing	319	Safety information for diesel fuel	48
Removing	318	Safety information for handling battery acid	47
C		Safety information for handling oils	45
Cab		Safety information for hydraulic fluid	46
Operating the interior lighting	226	Contact details	I
Operating the rear window heating	227	Coolant and cooling fluid	50
CE labelling	5	Cooling fluid	321
Changes to the forklift truck	27	Topping up	71, 321
Changing the air filter insert	323	Copyright and trademark rights	17
Changing the drive direction	126	Coupling pin in the counterweight	232
Dual pedal version	129	Uncoupling	233
Changing the fork arms	159	Crane loading	292
Changing the heating system fresh air filter	341	Determining the loading weight	293
Changing the password	91	Hooking on the lifting straps	293
Check the coolant concentration	321	Cruise control	218
Checking the cooling fluid level	71		
Checking the door latch	332	D	
Checking the driver's seat	331	Damage	30
Checking the emergency off function	101	Danger area	171
Checking the engine oil level	72	Danger to employees	41
Checking the exhaust gas system	343	Declaration of conformity	6
Checking the fork arms	346	Defects	30
Checking the lift cylinders and connections for leaks	345	Defining the driver PIN	87
Checking wheel fastenings	333	Definition of directions	20
Clamp locking mechanism		Description of the truck	2
Releasing	205	Diesel engine emissions	
Cleaning the electrical system	277	Checking	42
Cleaning the truck	275	Diesel fuel	48
Cleaning the windows	278	Non-road fuels	272
Climbing into the truck	73	Specifications	269
Climbing out of the truck	73	Sulphur content	271
Clipboard	230	Topping up	273
		Winter operation	271

Dimensions	348	Driveways	119
Direction indicators	211	Driving	
Fingertip version	212	Ascending gradients	139
Mini-console version	213	Descending gradients	139
Mini-lever version	211	Driving lights	
Display and operating unit	58	Switching on and off	209
Additional indicators	105	Driving on lifts	180
Adjusting the displays	106	Driving on loading bridges	181
Configure Blue Q	113		
Standard display elements	83, 105	E	
Display messages		Eberspächer particle filters	
Display content	244	Changing the fuel filter	345
Drive-specific	256	Regeneration	326
General	247	EC declaration of conformity in accordance with Machinery Directive	6
Display operating unit		Effects on additional consumers	115
Resetting the daily kilometres	111	Electric parking brake	
Setting the date	111	Emergency operation	284
Setting the language	112	Malfunctions	263
Setting the time	111	Emergencies	
Display symbols	106	Disconnecting the battery	285
Auxiliary equipment soft key functions	108	Emergency operation of the electric parking brake	284
Error messages	108	Truck tipping over	281
Menu navigation soft key functions	109	Using the emergency hammer	282
Numeric keypad	110	Emergency hammer	282
Operating messages	106	Emergency lowering	282
Status LEDs	109	Emergency shutdown	279
Warning messages	107	Emissions	52
Disposal		Exhaust gases	54
Battery	22	Heat	54
Components	22	Noise emissions	52
Documentation scope	15	Vibrations	53
Double mini-lever	60	Entering the access code	85
Lifting/lowering the fork carriage	153	Ergonomic dimensions	354
Tilting the lift mast	153	Error code table	245
Driver rights, duties and rules of behaviour	25	Example	167
Driver's cab		F	
Use	97	Filling the washer system	217
Drivers	25		

Fingertip	64	Impermissible use	12
Lifting/lowering the fork carriage ...	158	Information for carrying out maintenance	304
Tilting the lift mast	158	Maintenance timeframe	305
Fitting attachments	182	Information symbols	17
FleetManager	217	Insulation testing	44
Shock recognition	218	Insurance cover on company premises ...	27
Fork arms		Interior lighting	226
Length	33	Issue date of the operating instructions ...	17
Fork extension	161	J	
Four-way mini-lever	62	Jacking up	302
Fuel filter		Joystick 4Plus	63
Changing	344	Fork-carriage sideshift	157
Draining water	325	Lifting/lowering the fork carriage ...	156
Fuse assignment	356	Tilting the lift mast	157
Fuse box		Jump starting	286
Fuses	356	L	
Relays	356	Lashing	291
G		Lift cut out	
General	4	Automatic	143
H		Lift mast	
Handling gas springs and accumulators .	32	Lubricating the roller track	338
Hazard areas	121	Removing	303
Hazard warning system	210	Securing against falling off	303
Hazards and countermeasures	38	Securing against tilting backwards ..	303
Heating system	228	Lift mast versions	
Air circulation	229	Hi-Lo lift mast	149
Defrost	229	Triplex lift mast	150
Switching on	228	Lift mast vertical position	144
Switching on the blower	228	Automatic approach	146
Hydraulic blocking function	151	Calibrating	148
Releasing	151	Description	144
Hydraulic fluid	46	Display	146
Hydraulic system		Possible restrictions	148
Checking for leaks	337	Run-in to end stops	146
Checking the oil level	336	Tilting the lift mast backwards	147
I		Tilting the lift mast forwards	147
Identification points		Lifting	302
Overview	8		

Lifting system		
Controlling using a double mini-lever	153	
Controlling using a quadruple mini-lever	155	
Controlling using a triple mini-lever	154	
Controlling using the fingertip	158	
Controlling using the joystick 4Plus	156	
Operating devices	152	
Lighting		
STILL SafetyLight	216	
Switching on and off	209	
List of abbreviations	18	
Load		
Picking up	173	
Setting down	178	
transporting	177	
Load capacity	166	
Load chains		
Cleaning	278	
Load measurement	167	
Description	167	
Execution	168	
Zero adjustment	102	
Lubricating the joints and controls	329	
M		
Maintenance data table	314	
Battery	314	
Controls/joints	314	
Cooling system	316	
Drive axle	315	
Electrical system	314	
Engine	316	
Fuel tank	316	
General lubrication points	314	
Hydraulic system	314	
Lift mast	315	
Load chains	316	
Steering axle	315	
Tyres	315	
Washer system	316	
Maintenance during the break-in period	320	
Maintenance work without special qualifications	304	
Malfunctions during lifting mode	150	
Malfunctions in the electric parking brake	263	
Measuring the insulation resistance of the electrical system	44	
Medical equipment	32	
Message		
? VERTICAL POSITION	251	
ACCELERATOR	249	
ADBLUE FILLING LEVEL	258	
ADBLUE QUALITY	258	
ADBLUE QUALITY URGENT!	258	
ADBLUE REFILL 5l	258	
ADBLUE URGENT!	257	
AIR FILTER	261	
ALTERNATOR	260	
APPLY HANDBRAKE	248	
ARE YOU SURE ?	253	
ASH LOAD	259	
BRAKE SENSOR	249	
CODE DENIED	249	
COOLANT LEVEL	260	
CUTOFF MODE	257	
EMERGENCY SWITCH	251	
EMPTY	260	
EXH.GAS PURIFIER	256	
EXH.GAS PURIFIER PLEASE WAIT	257	
EXH.GAS PURIFIER SERVICE!!!	257	
FUEL FILTER	259	
GLOW	259	
HYBRID SYSTEM	259	
HYDRAULIC PUMP	259	
LOWER FORKS	250	
LPG AUTO. VALVE	261	
NOT VALID	256	
OIL PRESSURE	261	
OVERHEATING	255	
PARK. REG. ERROR	262	

PARK. REG. URGENT!!!	262	Opening the side windows	224
PARKING BRAKE ACTIVE	249	Operating company	24
PARKING BRAKE: APPLY HANDBRAKE!	250	Operating devices for hydraulic and driving functions	59
REFERENCE CYCLE	251	Operating materials	
REGENERATION COMPLETED	261	Quality and quantity	312
RELEASE PARKING BRAKE	249	Operating procedures	20
SAFETY BELT	252	Operating the service brake	130
SCR-SYSTEM MALFUNCTION	262	Operating the signal horn	94
SCR-SYSTEM SERVICE	262	Ordering spare parts and wearing parts	311
SEAT SWITCH	253	Overall view	
SERVICE BRAKE	248	Driver's compartment	57
START IC ENGINE	263	Overhead guard	
START PARK. REG.?	262	Drilling	29
STEERING	250	Roof loads	29
SURVEILLANCE	256	Welding	29
SWITCH OFF TRUCK?	249		
TILTING SPEED	250	P	
Messages		Packaging	22
Drive-specific	256	Parking brake	131
General	247	Electric parking brake	133
Mini console	65	Mechanical parking brake	131
Misuse of safety systems	30	Parking the truck securely	141
MSG 65/MSG 75 driver's seat		Particle filter	
Adjusting	75	Operational requirements	43
Adjusting the backrest extension	78	Personnel qualifications	304
Adjusting the lumbar support	78	Picking up loads	170
Adjusting the seat backrest	76	Pin in the counterweight	
Adjusting the seat suspension	77	Coupling	232
Moving	76	Place of use	13
Switching the seat heater on and off	79	Procedure if truck tips over	281
N		Production number	11
Nameplate	10	Prohibition of use by unauthorised persons	26
Neutral position	123	Proper usage	11
O		Push-up roof window	229
Oils	45	Q	
Opening the bonnet	317	Quadruple mini-lever	
Opening the cab door	223	Lifting/lowering the fork carriage	155
		Tilting the lift mast	155

R

Radiator	
Checking for leaks	321
Cleaning	321
Radio	227
Rear window heating	227
Reducing speed with a raised load	140
Relays	356
Replacing fuses	336
Resetting the daily kilometres	111
Resetting the daily operating hours	111
Residual dangers	34
Residual risks	34
Retrofitting	27
Returning to service after storage	297
Reversible fork arm	
Checking	346
Reversible fork arms	163
Ribbed V-belt	
Checking condition and tension	343
Roadways	121
Ascending gradients	120
Descending gradients	120
Dimensions of aisle widths	119
Dimensions of roadways	119
Rotating beacon	210
Rules for roadways and the working area	121

S

Safety devices	302
Safety inspection	42
Safety regulations for maintenance	
General information	300
Safety devices	302
Set values	302
Working on the electrical equipment	301
Working on the hydraulic equipment	300
Working on the ignition system	301

Safety regulations for working on the lift mast	302
Safety regulations when driving	117
Safety regulations when handling loads	165
Schematic views	20
Scope of the documentation	
UPA solutions	16
Seat belt	94
Checking	330
Cleaning	331
Fastening	95
Fastening on a steep slope	96
Maintaining	330
Malfunction due to cold	96
Releasing	96
Replacement after an accident	331
Selecting the drive direction	122
Selecting the driver PIN	88
Set values	302
Setting chocks	291
Setting the date	111
Setting the drive programs	122
Setting the language	112
Setting the time	111
Shock recognition	218
Shutting down the truck	295
Special risks	35
Stability	35
Starting drive mode	
Dual-pedal version	127
Starting the engine	98
Starting to drive	125
Status LEDs	109
Steering	138
Steering system	
Checking for correct function	101
Storage	297
Storing the truck	295
StVZO (Road Traffic Licensing Regulations) information	11
Switching off the truck	141
Switching on the key switch	81

T	
Technical data	
Dimensions	348
Three-way mini-lever	61
Topicality of the operating instructions	17
Towed load	231
Towing	288
Proper use	12
Trailers	
Towing	242
Transport	290
Transporting pallets	172
Transporting suspended loads	172
Triple mini-lever	
Lifting/lowering the fork carriage	154
Tilting the lift mast	154
Types of lift mast	148
Telescopic mast	149
Tyres	
Safety principles	30
U	
Unlocking the emergency off switch	80
Using working platforms	14
V	
Variants	
Access authorisation with PIN code	84
Automatic lift cut out	143
Automatic shut-off of the internal combustion engine	140
Clamp locking mechanism	205
Clipboard	230
Cruise control	218
Emergency off switch	80
FleetManager	217
Fork extension	161
Hi-Lo lift mast	149
Lift mast vertical position	144
Lifting systems	143
Load measurement	167
Push-up roof window	229
Radio	227
Reducing speed with a raised load	140
Reversible fork arms	163
Shock recognition	218
Triplex lift mast	150
Wheel chock	142
Windscreen wiper/washer	217
Zero braking	131
VDI datasheet	
RX70-16	350
RX70-18	350
RX70-20	350
Vertical lift mast position	
Checking for correct function	104
View of functions and operations	20
View of operating procedures	20
Views of the display operating unit	21
Visual inspections	68
W	
Warning regarding non-original parts	29
Wheel chock	142

Wheels and tyres	
Checking air pressure	332
Checking condition and wear of the tyres	333
Checking wheel fastenings	333
Servicing	332
Windscreen wiper/washer	217
Working at the front of the truck	302
Working on the electrical equipment . . .	301
Working on the hydraulic equipment . . .	300
Working on the ignition system	301
Working spotlights	
Automatically switching on/off	215
Lift-height-controlled switching on/off	215
Manually switching on/off	214
Switching on and off	209, 214
Z	
Zero adjustment of the load measure- ment	102

STILL GmbH

174749 EN – 03/2017